

Altitude Basic Height Adjustable Base

Assembly Instructions

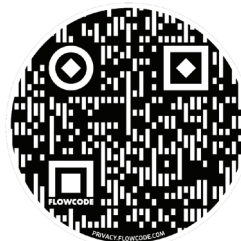

For additional installation information, simply use your phone's camera to hover over the QR code.

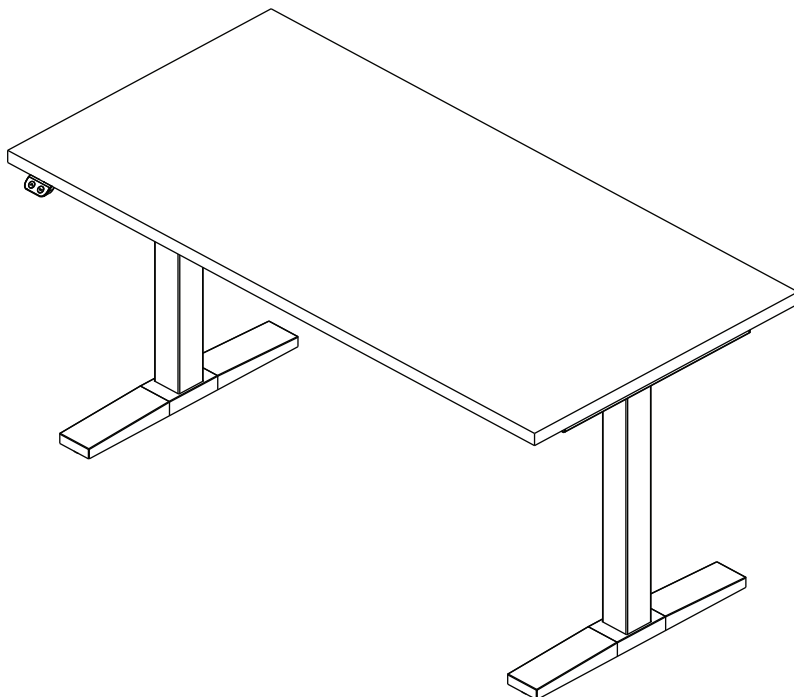

⚠ WARNINGS

- ⚠ Carefully read all instructions and review all illustrations before installing. Failure to observe these warnings could result in a fire, electric shock, or personal injury.
- ⚠ Table should be built in the room it is intended to be used in. Use two people when flipping or moving the table.
- ⚠ Ensure there are no obstacles above or below the table that would prevent movement. All cords must be of appropriate length to accommodate the table's full range of heights.
- ⚠ Keep unsupervised children away from this height adjustable table. Ensure children understand the dangers of operating this table without supervision.
- ⚠ Keep electrical components away from liquids. Components to be opened by professional technicians only. Use this table indoors only.
- ⚠ Do not sit or stand on table's base or worksurface. Weight rating is 180 lbs including worksurface. Do not exceed.
- ⚠ This table is designed for a 10% duty cycle, meaning, for every minute of operation the table should be allowed to rest for 9 minutes.
- ⚠ In the event of a power outage, or if any cord is unplugged, an initialization is required. See step 12 for initialization steps.

Included Hardware / Tools

14x M5x25 8x M6x15 13x M3.5x15 2x Cotter Pin

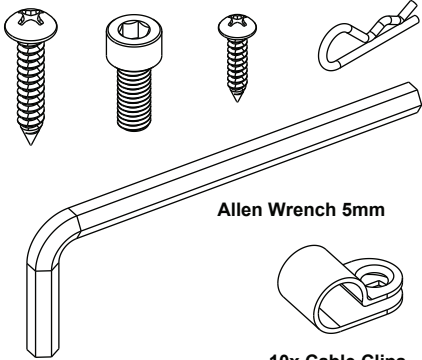

Allen Wrench 5mm



10x Cable Clips

Other Tools Required

#2 Phillips

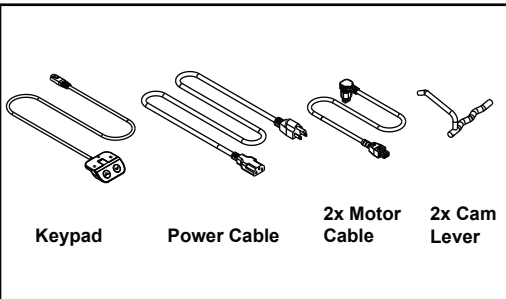
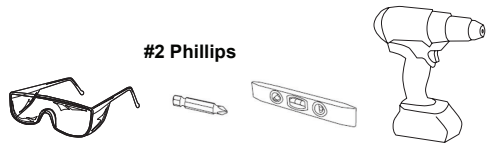

Keypad

Power Cable

2x Motor Cable

2x Cam Lever

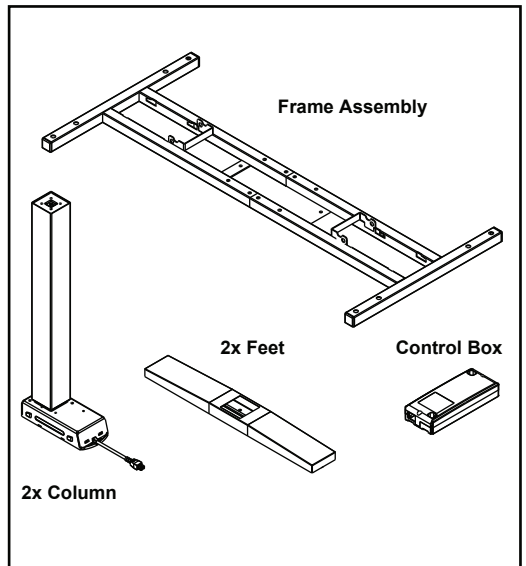

Frame Assembly

2x Feet

Control Box

2x Column

Step 1: Worksurface

- Place worksurface upside down on cardboard or carpeted surface to protect finish.
- Place frame assembly on bottom of worksurface.

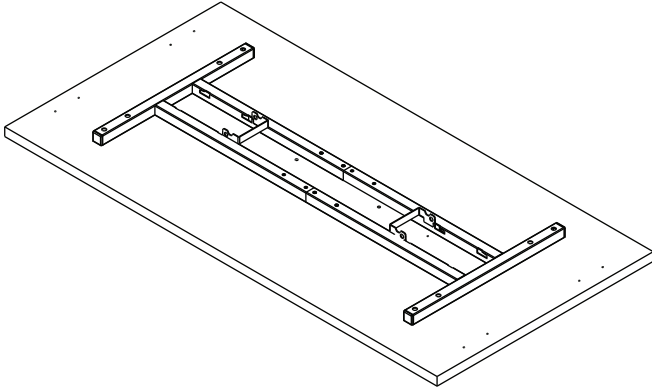

Step 2: Adjust Frame

- Using the allen wrench, loosen the 8 set screws on frame assembly 1 or 2 turns.
- If using a worksurface with pilot holes, align frame to those holes, sliding the frame apart as needed.
- If using a worksurface without pilot holes, slide the frame apart so the ends are 1" from the side of the worksurface. Center the frame front to back.

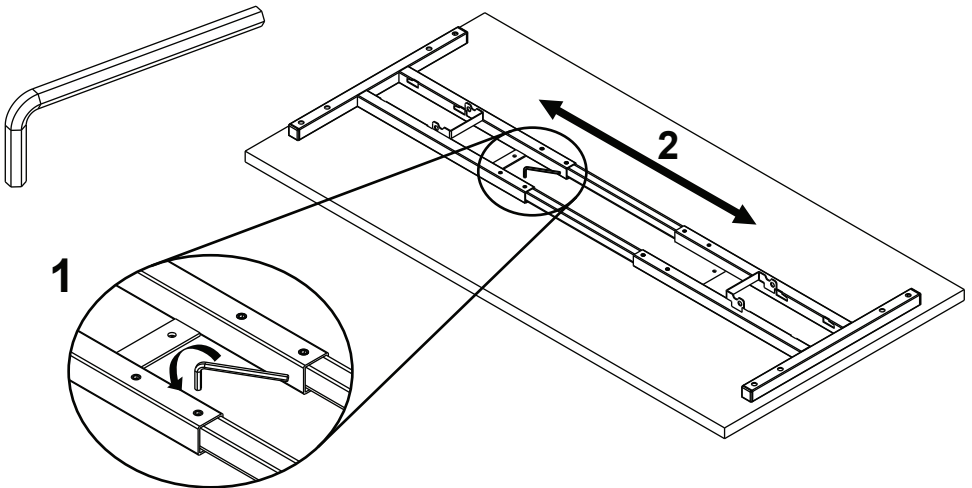

Step 3: Attach Frame & Control Box

- Using a power drill and a #2 Phillips bit, drive 14 - M5x25 screws to attach the frame assembly and control box to the worksurface. The control box should be placed behind the frame assembly at the back of the worksurface. There are no pilot holes for the control box location.

14x M5x25

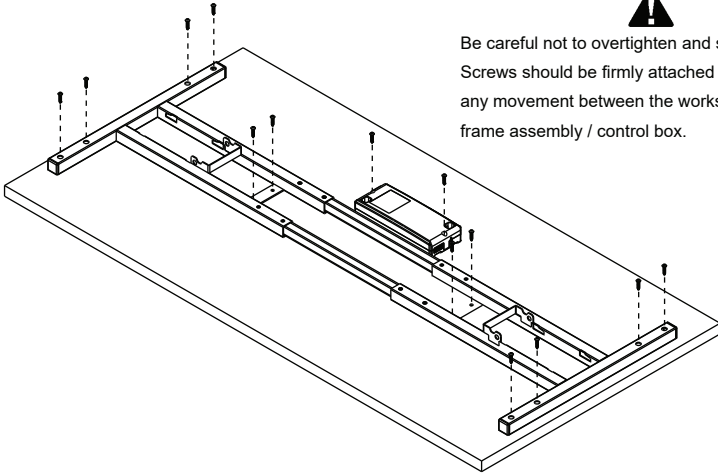
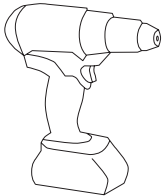
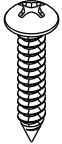

Be careful not to overtighten and strip screws. Screws should be firmly attached to prevent any movement between the worksurface and frame assembly / control box.

Step 4: Tighten Adjustable Frame

- Tighten set screws that were loosened in step 2.

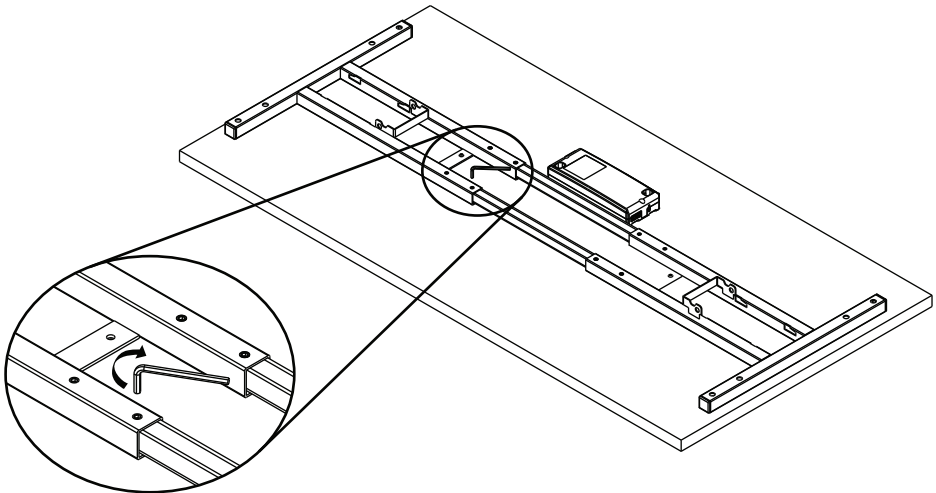

Step 5: Install Columns

- Insert column into the frame assembly by lining up the protrusions on the column with the slots in the frame assembly.
- Slide the column back. Ensure the cord is routed under the frame assembly bracket.
- Repeat for the other side.

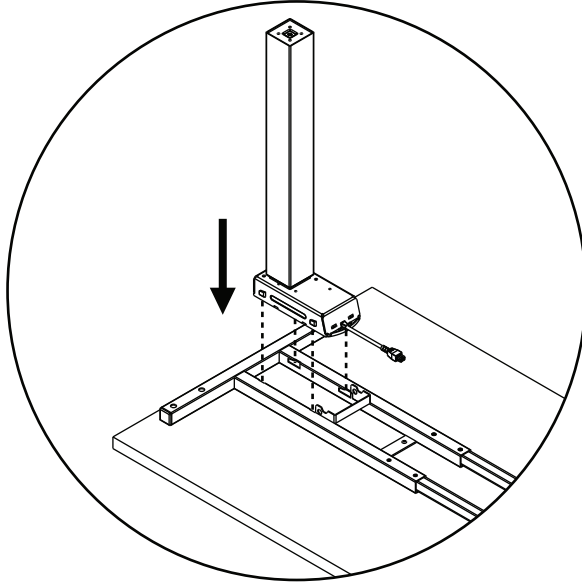

2X

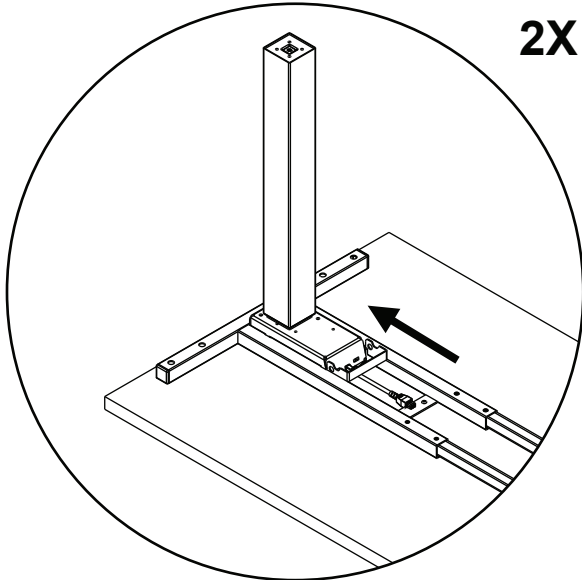

Step 6: Install Cam Locks for Columns

- Remove the cotter pin from the cam lock and save.
- Install the cam lock into frame by sliding the long end into one hole, rotating down, then sliding the short end into the other hole.
- Rotate the cam lock handle down to lock the column into place.
- Reinstall the cotter pin to prevent the cam lock from unlocking.
- Repeat for other side.

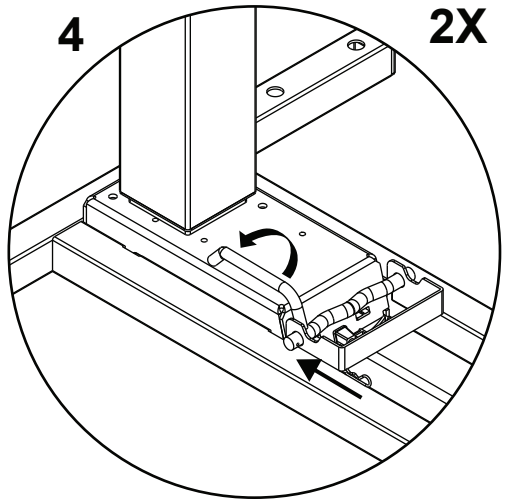
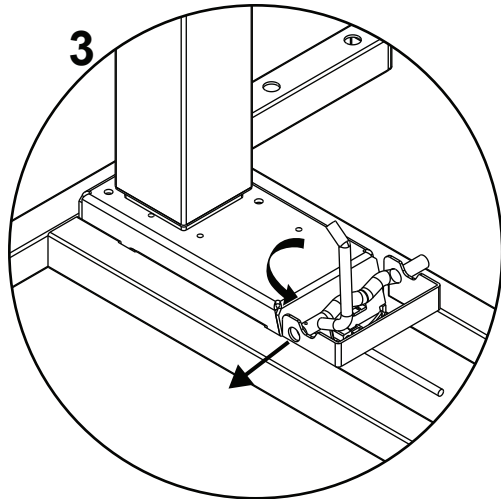
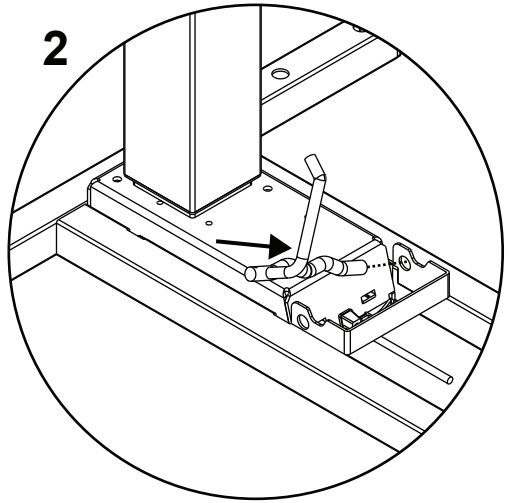
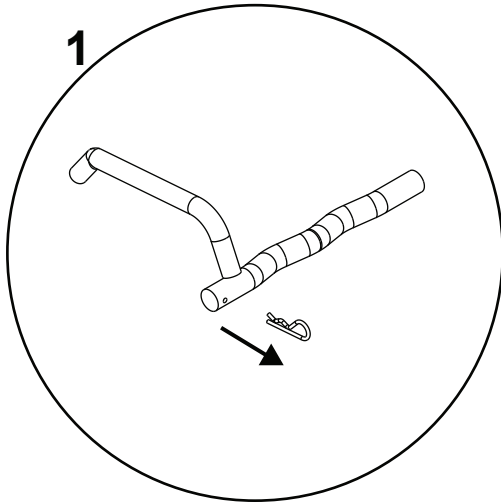

Step 7: Install Feet

- Install the feet using 4 – M6x15 screws with the provided allen wrench.
- Loosen the glides using the allen wrench to make leveling easier later.

8x M6x15

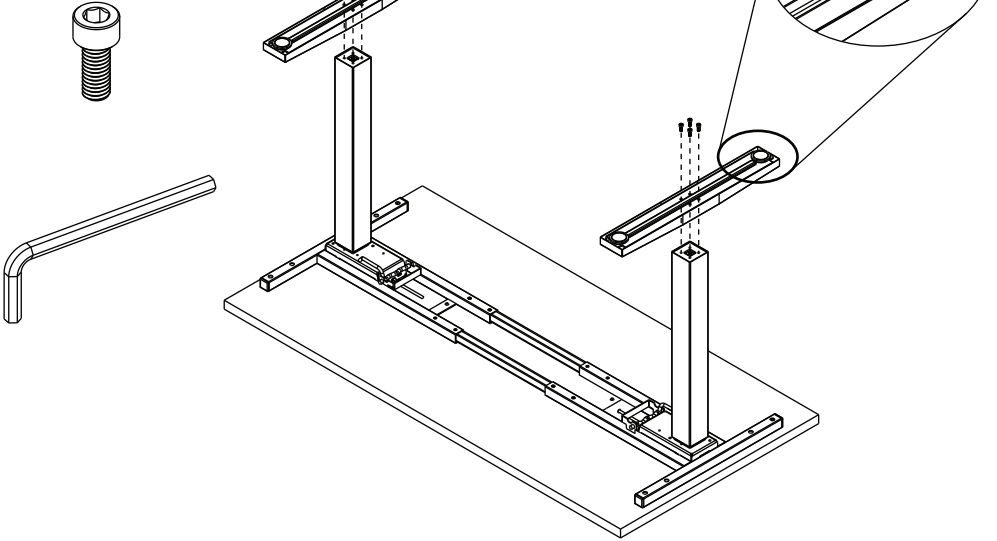

Step 8: Install Keypad

- Place the keypad at the front edge of the worksurface where desired.
- Using a power drill and a #2 Phillips bit, drive 3 - M3.5x15 screws to attach the keypad to the worksurface.

3x M3.5x15

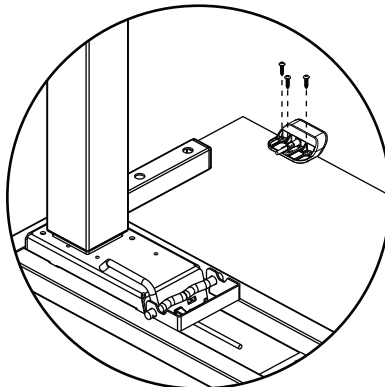
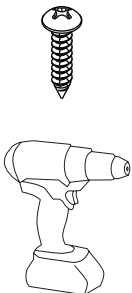

Be careful not to overtighten screws to prevent damage to the keypad.

Step 9: Attach Cables

- Plug in the keypad cable into the control box using either available port.
- Using the motor cables, plug the columns into the control box. The right-angle ends plug into the top of the control box.
- Plug in the power cable into the control box.

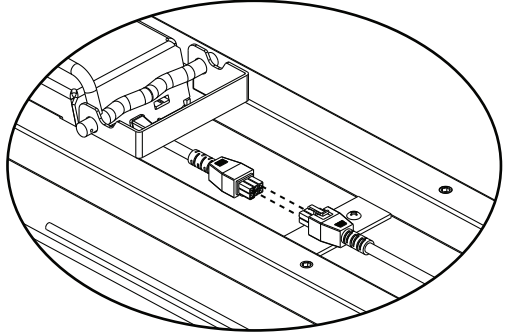
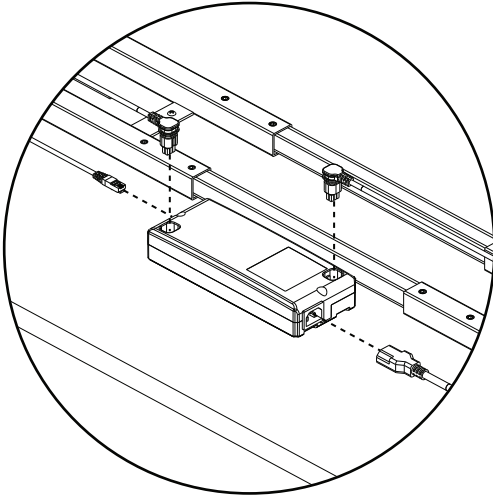

Step 10: Organize Cables

- Use the cable clips and M3.5x15 screws to organize the cables to the underside of the worksurface.
- Do not leave cables hanging.
- Leave enough slack in the power cord to reach electrical outlet when table is at full height.

10x M3.5x15

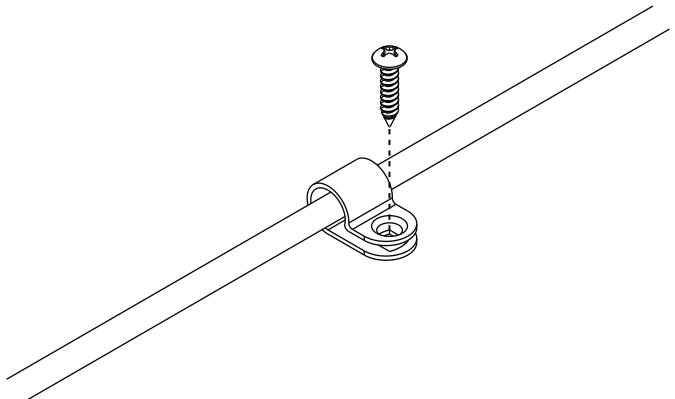
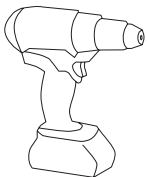
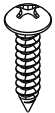

Step 11: Prepare for Use

- Using 2 people, flip the base over.
- Adjust leveling glides as needed to level base.
- Plug the power cable into an electrical outlet.

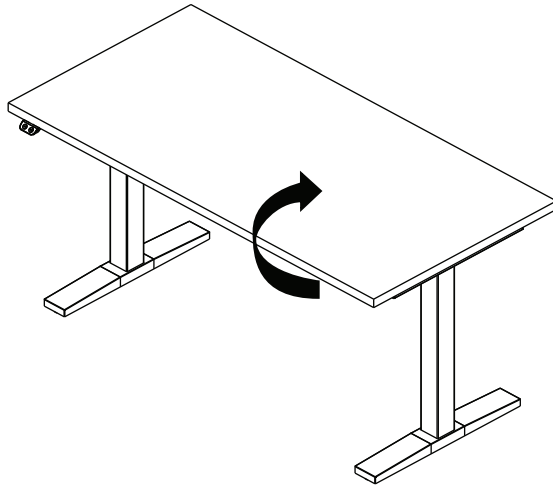

Step 12: Initialization

- The base must be initialized before use, after any power loss, and after every 6 months to ensure proper operation. Remove all obstructions under the base before initializing.
- To initialize, hold down both up and down buttons on the keypad.
- Continue to hold down both buttons as the base lowers to its lowest height, reaches the bottom, and raises up slightly.
- It is now ok to release the buttons. The base is initialized and ready for use.

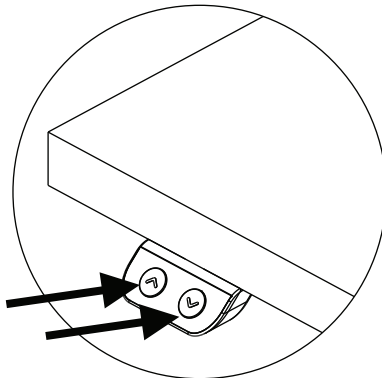

Anti-collision

- This table is equipped with a gyroscopic anti-collision system that is designed to detect unexpected changes in velocity and quickly reverse the motion of the table. This anti-collision system is only intended to help reduce the risk of the table causing accidental injury or damage and will not completely prevent incidents of collision.

Extreme care should always be used when operating this table to ensure no obstructions interfere with its motion.

Troubleshooting

- If the table is not functioning properly, check the following:
 - o Verify the base has power from a functioning electrical outlet.
 - o Check all cables are securely connected.
 - o Verify there is not excessive weight on the worksurface or that it is not distributed across the surface.
 - o Perform the initialization procedure from step 12.
- If the table is still not functioning properly, please contact Allsteel Customer Service at 1-888-255-7833.