

### 1 Arm Rest

Raise or lower arms to help support forearms and to keep shoulders aligned in a neutral position.

Press button to move arm rest up and down.

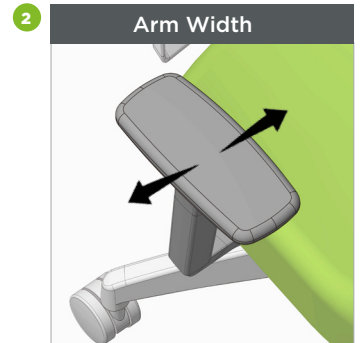

### 2 Arm Width

Adjust the width of the arms based on personal preference and body size. Keep them as close to the torso as possible for maximum support.

Slide the arm pads in or out to adjust the arm width.

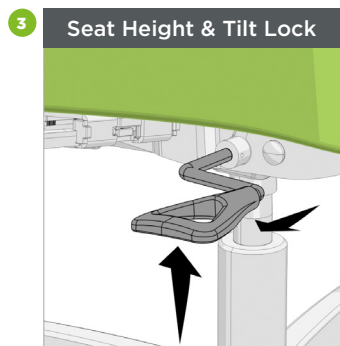

### 3 Seat Height & Tilt Lock

Adjust the seat height to find the optimal seated position. Legs should be at ninety degrees for the best support. Back can be locked in an upright position or set to recline freely.

Pull lever up to adjust seat height. Pull lever in and out for tilt lock.

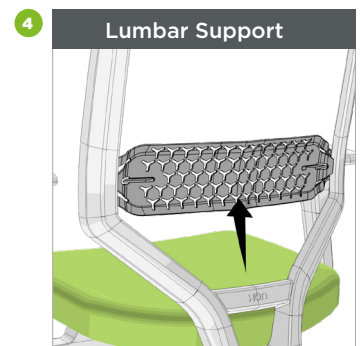

### 4 Lumbar Support

Adjust the lumbar support to best fit the user. The lumbar provides proper support to the lower back.

Slide up or down for desirable comfort.

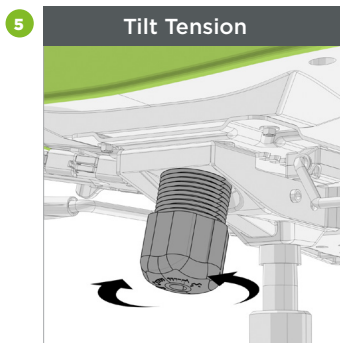

### 5 Tilt Tension

Proper tension should allow you to lean back easily while providing support when reclining.

Turn knob forward or backward to adjust the tilt tension.

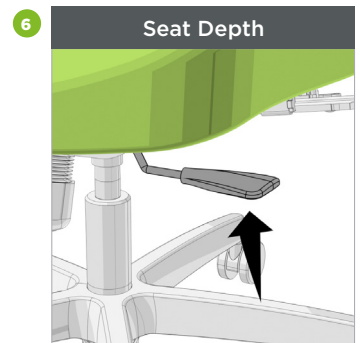

### 6 Seat Depth

The seat slides forward and back to a position that best supports the leg length and reduces pressure, providing long-term comfort.

Pull lever up to adjust seat depth.