

Architectural Products®

Specification Guide 2024

PDF updated May 20, 2024

Our unwavering commitment to our customers compels us to care, and our dedication to quality is just one of the ways we show our customers how much they mean to us.

We recognize that keeping up with the pace of change requires having products that work as hard as the people who use them. That's why each of our products is rigorously tested and certified to meet the highest industry standards.

In the unlikely event that any Allsteel product or component covered by the Allsteel Warranty should fail under normal workplace use because of defective material or workmanship, Allsteel promises to fix it. Because taking care of *people* is how Allsteel takes care of business.

For information on Allsteel's warranty coverage, visit [AllsteelOffice.com](https://www.AllsteelOffice.com).

Limited Lifetime Warranty	2	Beyond Panel & Trim Overview.....	76-163
Table of Contents	3	Working with Seismic	76-79
New, Revised, and Discontinued Products	4	Working with Freestanding.....	80-86
COM, Special Paint, Stain, and Laminate Policies.....	5-7	Working with Freestanding: SDC A-B	87-96
Sample Yardage and Fabric Care.....	8	Working with Freestanding & Wood Slats: SDC A-B.....	97-101
Veneer Care.....	9	Working with Freestanding: SDC C-F	102-108
Beyond Sustainability Information.....	10-11	Working with Freestanding & Wood Slats: SDC C-F.....	109-111
Aspect Sustainability Information	12-13	Working with Beyond Supported Suspended Ceiling.....	112-115
Site Review	14	Working with Ceiling Attachment	116-118
		Working with Base Channel & Leveling.....	119-121
		Working with Acoustic Performance	122-123
		Working with Frameless Panels & Trim	124-129
		Working with Framed / Solid Panels & Trim.....	130-155
		Working with Technology & Furniture Integration	156-163
		Beyond Panel & Trim Specifications.....	164-190
Aspect		Seismic Anchors	164
Table of Contents	15	Freestanding & Suspended Ceiling.....	165-166
Aspect Finishes	16	Ceiling Channel, Splice Kits, Clips, Spacer.....	167-168
Aspect Panel & Trim Overview	17-35	Frameless Glass, Trim, Keys, Vertical Fillers.....	169-172
Working with Seismic	17-21	Framed Glass & Wood Slat Infill Panels.....	173-176
Working with Product Tolerance & Field Measurements	22-25	Solid Panels, Frames, Tiles.....	177-186
Working with Site Requirements	26-30	Framed / Solid Base Trim & Zippers	187-188
Working with Panels & Trim	31-35	Technology & Furniture Integration	189-190
Aspect Panel & Trim Specifications	36-37	Beyond Door & Hardware Overview	191-209
Frameless Glass & Vertical Fillers	36	Door and Hardware Matrix	191-193
Universal Trim	37	Working with Doors	194-204
Aspect Door & Hardware Overview	38-49	Working with Hardware	205-209
Door and Hardware Matrix	38-40	Beyond Door & Hardware Specifications	210-233
Working with Doors	41-45	Freeway & Support Bracket.....	210
Working with Door Hardware.....	46-49	Sliding Doors, Frames, Mounting Hardware.....	211-217
Aspect Door & Hardware Specifications	50-64	Pivot Doors, Frames, Mounting Hardware.....	218-222
Sliding Doors	50-52	Hinged Doors, Frames, Mounting Hardware.....	223-228
Pivot Doors	53-55	Door Hardware	229-233
Hinged Doors	56-59	Beyond Connector Overview.....	234-252
Door Hardware.....	60-64	Working with Frameless Connectors.....	234-237
Aspect Connector Overview.....	65-68	Working with Connectors	238-251
Working with Connectors	65-67	Working with Kits	252
Working with Service & Touch Up Paint Kits.....	68	Beyond Connector Specifications.....	253-265
Aspect Connector Specifications.....	69-70	Frameless Wall Channel, Adapter, Finished End, U-Channel	253-255
Wall Channels, Service Kit, & Touch Up Paint Kits.....	69	Wall Channel Door Adjacent, Small, Large	256-257
Drywall Endcap & Adapter	70	Posts, Zipper-Based Connector, Drywall End Cap	258-263
		Finished End & Solid U-Channel.....	264
		Installation, Hard Surface, and Touch Up Paint Kits	265
Beyond		Beyond Electrical & Data Overview.....	266-281
Table of Contents	71	Working with Frameless Electrical & Data	266-270
Beyond Finishes.....	72	Working with Framed and Solid Electrical & Data.....	271-281
Beyond Fabrics.....	73	Beyond Electrical & Data Specifications.....	282-286
Beyond Partnership Program Upholstery.....	74	Frameless Electrical & Data	282-283
Beyond Frame & Polymer Finish Matrix.....	75	Framed and Solid Electrical & Data.....	284-286
		Beyond Frameless Privacy Tile System	287-300
		Beyond Viz.....	301-311

COM Program

Allsteel understands that customers may at times want to specify fabrics outside of Allsteel's standard fabric offering. Our COM program was designed to make specifying COMs on Allsteel products a simpler, friendlier, and hassle-free process. This process is simple and easy to use, and is described below under "Allsteel to Supply." If Dealers wish to manage the COM process themselves, they can do so by following guidelines under "Dealer to Supply." Find out more about Allsteel's COM process by emailing our COM Department at ASICSCOM@allsteeloffice.com.

Allsteel to Supply:

1. Select the fabric you wish to use and check the Tailored Solutions Application on [our Website](#). You need the COM supplier's name, fabric pattern name, and color name to search for approved fabrics.
2. If your fabric is listed as an approved fabric for Stride® or Beyond, you may place your selection with your Beyond Planner. Please use the fabric code (e.g., P242761XP) from the Tailored Solutions Test Request. **Make sure to confirm with your Beyond Planner that fabric is "Allsteel to Supply."** If your fabric is not listed as approved, you will need to complete a COM Test Request on Tailored Solutions. Allsteel will arrange to obtain the test fabric and you will be notified of the results within 3 to 5 working days of receipt of the test yardage by Allsteel.
3. If the fabric is approved, you will receive an email summary from Tailored Solutions with the correct price grade and fabric code for order purposes. Written COM price quotes hold pricing for 90 days after issue date.
4. Once the fabric has been approved by Allsteel, the code can be supplied to your Beyond Planner for submittal of your order. Allsteel will purchase all COM fabric directly from the COM suppliers and schedule for production.

In the event that the Dealer decides to cancel a COM fabric order, the Dealer is responsible for the cost of the fabric plus a handling charge that is equal to 10% of the fabric cost.

Dealer to Supply:

1. Select the fabric you wish to use and check the Tailored Solutions Application on [our Website](#). You need the COM supplier's name, fabric pattern name, and color name to search for approved fabrics.
2. If your fabric is listed as approved for Stride® or Beyond, work with your Beyond Planner and Beyond Project Specialist to determine yardage required for your order.

3. If your fabric is not listed as already tested and approved, you will need to complete a COM Test Request on Tailored Solutions. You will need to arrange for the test fabric to be sent to:

Panel Test Fabric:

Allsteel Inc.
Attn: Com Dept.
Dock Doors 46-48
3000 North Hwy 61
Muscatine, IA 52761

Allsteel requires 3 yards of fabric for each panel system fabric being tested. Make sure to include two memo samples for each fabric to be tested with the test fabric. You will be notified of the test results within 3 to 5 working days of receipt of the test yardage by Allsteel.

4. Work with your Beyond Planner to specify your chosen fabric for your order, **making sure to clearly specify that it will be Dealer to Supply.**
5. All "Dealer to Supply" orders will be charged Grade B for panels. Dealers will pay for the COM fabric separately.
6. All "Dealer to Supply" fabric must be sent on a fabric roll.
7. Place your fabric order directly with the COM Supplier with instructions for the fabric to be sent on a fabric roll to:

HNI Fabric Distribution Center – Dealer PO Number COM Production Yardage

Allsteel Inc.
Attn: COM Team
200 Oak St.
Muscatine, IA 52761

Information that **MUST** be included in the packing slip attached to the fabric:

- a. Dealer's Purchase Order Number to Allsteel
- b. Allsteel's tracking number for the COM fabric
- c. Dealer Name
- d. Yards of fabric

If the fabric shipment does not match the correct fabric and yardage, Allsteel will notify the Dealer for resolution.

If Allsteel receives fabric with incorrect labeling that cannot be linked to an Allsteel furniture order, Allsteel will hold the fabric for up to 7 days, while the COM Expeditor attempts to identify the order. After 7 days, Allsteel will return the fabric to sender. There are no exceptions to this policy.

Any canceled orders are subject to cancellation charges up to the full value of the Allsteel product canceled. Allsteel will determine the actual cancellation charge at the time the cancellation is requested.

Additional Policy Information:

The Company assumes no responsibility for the overall appearance, flammability, normal durability, colorfastness, or any other quality standards. The Company reserves the right to reject a COM if the quality of the COM is not satisfactory for the product. Should this occur, the Customer will be notified with an explanation within 7 working days of receipt of test materials.

The Company is not responsible for fabric that has become obsolete at the COM supplier, that is of poor quality, or that is delivered late to the manufacturer from the COM supplier. Excess yardage will be disposed of at Allsteel's discretion.

All cancellations or changes to COM orders are subject to Company approval. Because of the nature of COM, special fabrics, finishes, and structural modifications, products ordered as special and then canceled prior to shipment are subject to cancellation costs up to the full value of the product canceled. The Company determines the actual cancellation charge at the time the cancellation is requested. Upon approval, a cancellation number is issued to the Customer.

Purchase orders will not be accepted or entered unless the testing process is complete with positive results.

If all testing has been previously completed, re-testing is only necessary if fabric is to be used on a different product, or pattern direction has changed from that previously approved.

Previous test results can be obtained by a Customer on the Tailored Solutions Application or by calling Allsteel Customer Support.

COM testing will require 3-5 working days from receipt of test yardage.

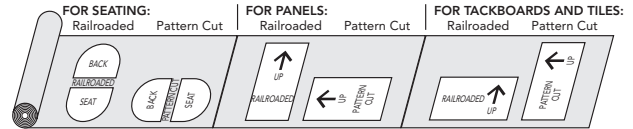

All COM fabric will be applied to seating and panel systems Pattern Cut unless Railroad Cut is requested and approved on the COM Test Request in Tailored Solutions. Any fabrics approved as a width pass, the dealer is responsible for clarifying Railroad Cut on orders containing items that are too large to support the Pattern Cut of a fabric application (any items larger than 48" high or wide).

Fire Retardant

The Dealer is responsible for ensuring that the COM fabric is certified to meet all flame retardant requirements.

For more information, please contact Allsteel Customer Support.

Special Paint and Stain Policy

Allsteel at its own discretion may modify its standard products with non-standard paint and stain colors to meet specific needs. Dealer is required to submit a special paint or stain request via the Tailored Solutions Application on [our Website](#). A sample of the non-standard paint or stain color desired will be required for matching. Pricing, lead time, and order information will be provided at the time of approval.

- For each new requested stain or paint, there will be a \$500 net fee to cover supplier costs to match the special item.
- For existing, previously-approved stains or paints, there is no \$500 matching fee, however, there is a sample chip fee of \$175 net for stains and \$100 net for paints.
- Samples, preferably at least 3" x 5" chips, of the exact color desired should be sent to the Allsteel Tailored Products Group. Paint matches require (3) sample chips and stain matches require (3) sample chips. Please mail these sample chips to the address below and reference the Special Item Request Number from Tailored Solutions.

Allsteel Inc.

Attn: COM Department
Dock Doors 46-48
3000 North Hwy 61
Muscatine, IA 52761

- Allsteel will color match the sample and send control samples to the address provided in the request. Dealer will review Allsteel's color match and approve by signing the back of the sample chip. Send the signed sample back to the Allsteel Tailored Products Group.
- Product pricing for all special paints falls under the Select Paint price grade.
- Orders will not be accepted until Allsteel receives the Dealer's written approval on the color match.
- Extended lead times will apply on orders containing special paints or stains.
- Due to manufacturing techniques, materials, and quality issues, some exclusions will apply and some matches may be declined.

Important Notes

- Natural veneer is subject to nature's quality control. Differences in grain and color are naturally occurring variations and cannot be controlled by the manufacturer and cannot be considered as product defects. Natural veneer has the characteristics and beauty of a living organism; with its own variations of grain, growth, and color patterns. For these reasons, Natural veneer is preferred by many for its warmth and personal characteristics.
- Color changes will occur over time when wood is exposed to light. For this reason, when new product is ordered as an addition to existing product, there will be color variances between the old and new product. Please remember when specifying new product that although the species of veneer will be the same, additional product is being manufactured from a different tree. It may take several months for the new furniture to mature to the color level of existing product. Even with this maturation process the additional product will not be an exact match.

Special Laminate Policy

The Company at its own discretion may modify its standard products with non-standard laminates to meet specific needs. Contact the Allsteel Tailored Products Group for pre-approved Wilsonart, Formica, Nevamar, and Pionite laminates and pricing for special laminates. When requesting a special laminate please supply manufacturer, along with name and pattern number of laminate.

- Extended lead times will apply on orders containing special laminates.
- Due to manufacturing techniques, materials, and quality issues, some product exclusions will apply and some requests may be declined.

16x20 Sample Yardage

- Sample yardage is available for both Seating upholstery and Systems fabrics.
- Samples have sewn edges, a grommet, and identifying label.
- Not available in COM fabrics.
- Swatch cards and 4" x 5" memo samples are available through Allsteel Advantage at 1-866-ALLSTEEL.

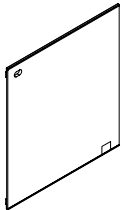

Model	Ship Weight	Cubes	List Price by Grade								
			1	2	3	4	5	6			
Seating Upholstery Sample — 16"H x 20"W											
SYSTG	.4 S	.2	\$ 111	\$ 123	\$ 131	\$ 138	\$ 151	\$ N/A			
			7	8	9	10	Leather 1	Leather 2			
			\$ 167	\$ 178	\$ 187	\$ 195	\$ 224	N/A	11	12	\$ 216

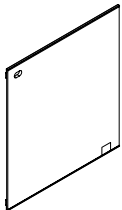

Model	Ship Weight	Cubes	List Price by Grade					
			A	B	C	D	E	F
Systems Fabric Sample — 16"H x 20"W								
SYSFS	.4 S	.2	\$ 89	\$ 95	\$ 100	\$ 110	N/A	N/A
<i>Specification Example: SYSFS.ECH902</i>								

Fabric Care

Cleaning instructions are listed on the back of our fabric cards and are available in written form upon request.

Cleaning Codes

- | | |
|--|---|
| <p>D Dry clean only.</p> <p>L Clean with warm water and mild soap, using clean cloth, as soon as possible.</p> <p>P Clean with detergent and water or perchlorethylene.</p> <p>R Detailed recommended cleaning and/or disinfecting procedures are available upon request.</p> <p>S Only pure, water-free solvents may be used. CAUTION: Use of water-based or detergent-based solvents may cause shrinking and/or permanent water stains.</p> | <p>SM Same as S. Do not brush.</p> <p>SW Clean with water-based cleaning agents, foam, or pure water-free solvents (Energine®, Carbona®, Renuzit®, or other similar products). Vacuuming or light brushing is recommended to prevent dust and soil buildup.</p> <p>W Water-based cleaning agents or foam may be used.</p> <p>WS See SW.</p> <p>X Brush or vacuum only.</p> <p>XS Brush and vacuum only, NO liquid cleaners.</p> |
|--|---|

S Shippable by small-package carrier.

Veneer Care Instructions

Veneer worksurfaces feature the Gunlocke® finishing system. The finishing system is a process that begins with the application of stains, which promote exceptional depth and clarity. Next the worksurface receives a specialized coating that provides exceptional durability and chemical resistance. The remaining surfaces receive a top coat. These finishing processes ensure depth, clarity, color consistency, and durability throughout the product.

Veneer worksurfaces have exceptional resistance to:

- Heat and moisture (hot beverages, pizza boxes)
- Chemicals (liquid paper, nail polish)
- Stains (permanent markers)
- Scratches and impact (everyday wear and tear)

Caring for your veneer finish:

- General maintenance procedures entail wiping clean the entire surface with a clean, water-dampened soft cloth once per week (be sure to wipe with the grain).
- Murphy's® Oil Soap may be used as a general purpose type cleaner with warm water to clean tops.
- The finish may also be polished with Guardsman® Furniture Polish (contains no waxes or silicones) to provide renewed luster.
- Be sure to wipe up all spills immediately. Do not allow spills to dry.

Wood owes its inherent beauty to variations in color, grain, and texture, and therefore, these variations are not considered defects. There may be minor variations from one piece of furniture to the next even though they are finished at the same time. Exposure to light and the aging process will cause a darkening of natural wood products. Light finishes on wood products do not mask the natural characteristics of wood. Allsteel does not guarantee the exact matching of grain, pattern, and color.

Beyond demountable walls play an important role in a workplace that is productive, healthy, and concerned with employee wellness and environmental impacts. Glass walls provide more natural light and better views to the outside, which improves productivity and enjoyment of the space. With more natural light entering the space, less artificial lighting is needed, requiring less energy to be used by the building and its tenant spaces. These factors have been shown to help with talent attraction and retention.

Being durable and truly movable allows Beyond walls to be used and reused longer, decreasing the need to extract, refine, and transport natural resources. The longer a product is used, the lower its environmental footprint. Beyond glass and solid walls drastically minimize off-gassing, compared to drywall painted on-site, so the workplace air quality is better for future occupants from the start. Beyond solid walls contain formaldehyde-free fiberglass. Good indoor air quality can contribute to higher productivity and other wellness benefits. Beyond is Indoor Advantage™ Gold certified and meets ANSI/BIFMA e3 credits 7.6.1, 7.6.2. and 7.6.3.

Beyond demountable walls are level®2 certified to the ANSI/BIFMA e3 Furniture Sustainability Standard. The product is evaluated by a third-party certifier on performance in the categories of materials, energy and atmosphere, human and ecosystem health, and social responsibility. Not only is the product audited against the standard, but also the manufacturing site and the organization. level®2 is the second-highest achievement.

LEED® Project Contributions

Beyond demountable Walls can support LEED® projects by contributing to several credits within LEED V4.

Energy & Atmosphere

Beyond's glass walls allow more natural light into a space in which may reduce energy use by decreasing the use of artificial lighting.

Materials & Resources

Long-Term Commitment: Beyond's ease of reconfiguration makes it easier for a tenant to make a long-term commitment to a space, knowing that it will be possible to rearrange the workplace to suit changing needs in the future.

Interiors Life-Cycle Impact Reduction, Options 1 and 3: Designing for reuse and flexibility, like using demountable and movable walls, helps lessen the environmental impacts of interior spaces over time. Change is inevitable; Beyond's ease of reconfiguration and reuse helps project teams better accommodate changing floorplates in short timeframes.

BPDO Sourcing of Raw Materials, Option 2: Although glass must be virgin material to achieve its clarity and strength, other components in the Beyond system have recycled content. Environmental Data Sheets are available for Beyond's various setups and provide details about the material types and recycled content. Beyond's wood components are also available as FSC Certified.

Construction and Demolition Waste Management: Allsteel's Beyond demountable walls product packaging can be recycled with other on-site wastes or off-site, depending on project preference.

Indoor Environmental Quality

Low-Emitting Materials: Many of the materials used in Beyond are non-emitting, including glass, aluminum, steel, and other hardware. These components do not off-gas into the workplace and do not require repainting or refinishing that could release VOCs (Volatile Organic Compounds). Beyond's components have been tested for emissions and are certified for indoor air quality through the SCS Global Services Indoor Advantage™ Gold program. Beyond also meets the CDPH v1.1-2010 emissions criteria.

Indoor Air Quality Assessment: Beyond may indirectly support this credit. Beyond uses components that are non-emitting and do not require any on-site finishing or touch-ups, meaning that indoor air quality will not be impacted by the installation of Beyond.

Interior Lighting: Beyond can be specified with a variety of finishes, many of which are lighter in color and may contribute to the Light Reflectance Values (LRV) needed to achieve strategy E of this credit.

Daylight: Beyond's glass walls allow more natural light into a space, which may support this credit.

Quality Views: Beyond's glass walls may provide occupants with access to views outside. Being able to access views to the outdoors has productivity benefits and may increase workplace satisfaction.

Acoustic Performance: Beyond has been tested for acoustic performance and may contribute to this credit, depending on the other materials selected for the interior spaces.

WELL Project Contributions

Beyond demountable walls can support WELL projects by contributing to several features within WELL V1.

Air 04: VOC Reduction: Good indoor air quality has been linked to improved productivity in office spaces. Allsteel's Beyond is SCS Indoor Advantage™ Gold certified and meets the referenced criteria in the WELL Building Standard (ANSI/BIFMA e3-2011 7.6.1 and 7.6.2).

Light 53: Visual Lighting Design: Balancing spatial brightness across a variety of spaces can contribute to sharper visual acuity and focus, while potentially reducing eye strain. Beyond's glass walls allow light to flow more deeply into the space than drywall and may help project teams with light balance from room to room.

Light 59: Surface Design: Exposure to light during the workday can promote alertness and activity. Choosing surfaces with high Light Reflectance Values (LRVs) can help increase the amount of light in a space without increasing unwanted glare. Allsteel's portfolio of paints, laminate, and veneer finishes include many options with an LRV of 0.5 or higher, contributing to this feature.

Light 61: Right to Light: Beyond's glass walls can increase access to views by employees if the building has sufficient vision glazing to allow views from the required areas. Offices and taller features placed in the interior of the space maximize view opportunities.

Comfort 78: Reverberation Time: Acoustic comfort in the office is crucial to productivity. Allsteel's Beyond may contribute to the acoustic requirements of this feature. Additional considerations should be made with the other elements of the space, like flooring, ceiling materials, and furnishings, which may also impact this feature.

Comfort 80: Sound Reducing Surfaces: Reducing sound in an office can contribute to more comfortable levels throughout the space. While Beyond's walls are primarily made of glass which may not have a high NRC, additional elements, like acoustic privacy tiles, can be added that may improve the acoustics within a space.

Comfort 81: Sound Barriers: Noise from adjacent spaces can be disruptive in a work environment. Sealing gaps between walls and adding thresholds for doors may help reduce noise between rooms.

Mind 87: Beauty and Design, Part 1: Occupants' moods and morale can be impacted by the design of their workspace. Integrating aesthetically pleasing elements into a space can provide a calming or joyful experience. Allsteel's Beyond demountable walls can be customized to create room layouts that capture and enhance their organizational culture and contribute to this feature.

Mind 88: Biophilia I Qualitative: Research has shown that humans with a connection to nature generally experience a stronger state of well-being, and biophilic elements can help reduce stress, while improving learning, healing, and worker productivity. Allsteel's Beyond walls are available with upholstery options and finishes that incorporate nature's patterns. Elements like natural wood veneer and wool upholstery can help contribute to a biophilic space.

Aspect™ demountable walls play an important role in a workplace that is productive, healthy, and concerned with employee wellness and environmental impacts. Glass walls provide more natural light and better views to the outside, which improves productivity and enjoyment of the space. With more natural light entering the space, less artificial lighting is needed, requiring less energy to be used by the building and its tenant spaces. These factors have been shown to help with talent attraction and retention.

Being durable and demountable allows Aspect walls to be used and reused longer, decreasing the need to extract, refine, and transport natural resources (when compared to traditional drywall construction). The longer a product is used, the lower its environmental footprint. Aspect glass walls drastically minimize off-gassing, compared to drywall painted on-site, so the workplace air quality is better for future occupants from the start. Good indoor air quality can contribute to higher productivity and other wellness benefits. Aspect is Indoor Advantage™ Gold certified and meets ANSI/BIFMA e3 credits 7.6.1, 7.6.2. and 7.6.3.

Aspect demountable walls are level®2 certified to the ANSI/BIFMA e3 Furniture Sustainability Standard. The product is evaluated by a third-party certifier on performance in the categories of materials, energy and atmosphere, human and ecosystem health, and social responsibility. Not only is the product audited against the standard, but also the manufacturing site and the organization. level®2 is the second-highest achievement.

LEED® Project Contributions

Aspect demountable walls can support LEED® projects by contributing to several credits within LEED V4.

Energy & Atmosphere

Aspect's glass walls allow more natural light into a space, which may reduce energy use by decreasing the use of artificial lighting.

Materials & Resources

Interiors Life-Cycle Impact Reduction, Options 1 and 3: Designing for reuse and flexibility – like using demountable and movable walls – helps lessen the environmental impacts of interior spaces over time. Aspect demountable walls may contribute to this credit.

BPDO Sourcing of Raw Materials, Option 2: Although glass must be virgin material to achieve its clarity and strength, other components in the Aspect system have recycled content. Environmental Data Sheets are available for Aspect's various setups and provide details about the material types and recycled content. Aspect's wood components are also available as FSC Certified.

Construction and Demolition Waste Management: Allsteel's product packaging for Aspect can be recycled with other on-site wastes or off-site, depending on project preference.

Indoor Environmental Quality

Low-Emitting Materials: Many of the materials used in Aspect are non-emitting, including glass, aluminum, steel, and other hardware. These components do not off-gas into the workplace and do not require repainting or refinishing that could release VOCs (Volatile Organic Compounds). Aspect's components have been tested for emissions and are certified for indoor air quality through the SCS Global Services Indoor Advantage™ Gold program. Aspect also meets the CDPH v1.1-2010 emissions criteria.

Indoor Air Quality Assessment: Aspect may indirectly support this credit. Aspect uses components that are non-emitting and do not require any on-site finishing or touch-ups, meaning that indoor air quality will not be impacted by the installation of Aspect.

Daylight: Aspect's glass walls allow more natural light into a space, which may support this credit.

Quality Views: Aspect's glass walls may provide occupants with access to views outside. Being able to access views to the outdoors has productivity benefits and may increase workplace satisfaction.

Acoustic Performance: Aspect has been tested for acoustic performance and may contribute to this credit, depending on the other materials selected for the interior spaces.

WELL Project Contributions

Aspect demountable walls can support WELL projects by contributing to several features within WELL V1.

Air 04: VOC Reduction: Good indoor air quality has been linked to improved productivity in office spaces. Allsteel's Aspect is SCS Indoor Advantage™ Gold certified and meets the referenced criteria in the WELL Building Standard (ANSI/BIFMA e3-2011 7.6.1 and 7.6.2).

Light 53: Visual Lighting Design: Balancing spatial brightness across a variety of spaces can contribute to sharper visual acuity and focus, while potentially reducing eye strain. Aspect's glass walls allow light to flow more deeply into the space than drywall and may help project teams with light balance from room to room.

Light 59: Surface Design: Exposure to light during the workday can promote alertness and activity. Choosing surfaces with high Light Reflectance Values (LRVs) can help increase the amount of light in a space without increasing unwanted glare. Allsteel's portfolio of paints, laminate, and veneer finishes include many options with an LRV of ½ or higher, contributing to this feature.

Light 61: Right to Light: Aspect's glass walls can increase access to views by employees if the building has sufficient vision glazing

to allow views from the required areas. Offices and taller features placed in the interior of the space maximize view opportunities.

Comfort 78: Reverberation Time: Acoustic comfort in the office is crucial to productivity. Aspect demountable walls may contribute to the acoustic requirements of this feature. Additional considerations should be made with the other elements of the space, like flooring, ceiling materials, and furnishings, which may also impact this feature.

Comfort 80: Sound Reducing Surfaces: Reducing sound in an office can contribute to more comfortable levels throughout the space. While Aspect is primarily made of glass which may not have a high NRC, additional elements, like acoustic privacy tiles, can be added that may improve the acoustics within a space.

Comfort 81: Sound Barriers: Noise from adjacent spaces can be disruptive in a work environment. Sealing gaps between walls and adding thresholds for doors may help reduce noise between rooms.

Mind 87: Beauty and Design, Part 1: Occupants' moods and morale can be impacted by the design of their workspace. Integrating aesthetically pleasing elements into a space can provide a calming or joyful experience. Allsteel's Aspect can be customized to create room layouts that capture and enhance their organizational culture and contribute to this feature.

Review Delivery Requirements

Offload Requirements

Determine if there are any delivery requirements or special delivery methods to be included in project cost.

Examples of questions to ask include:

- “Delivery to site or warehouse?”
- “Does the city allow 53' trucks to deliver to the site?”
- “Can a 53' truck access the planned offload area?”
- “Is there a loading dock?”

Freight Elevator/Crane Requirement/Stair Carry

During the pre-order site visit, determine the most appropriate delivery path from offload location to product staging area. Make sure the paths are sized adequately to accommodate the component or skid size, according to the planned method. Fully dimension elevator to insure ability to transfer product and check for any elevator booking requirements or restricted hours of delivery.

Staging Install – Product Placement

Review the floorplate in the area of install and/or talk to building officials to determine the best staging areas and delivery routes for easy install. If security is an issue, the dealer partner or contracted installation company is responsible for providing a secure environment to house the Beyond product upon delivery until the project is complete; losses due to theft will be the responsibility of the dealer partner or contracted installation company.

Key Recommendations

- As shown in the illustration below, please be aware of any obstacles in the ceiling, floor or horizontal connections. Examples of potential obstacles to be aware of are lighting, HVAC and sprinkler heads.
- Since the product will produce noise to install, please understand from the client any activity restrictions.
- If available, review floor finish type and transitions. For example, VCT location in relationship to carpet.

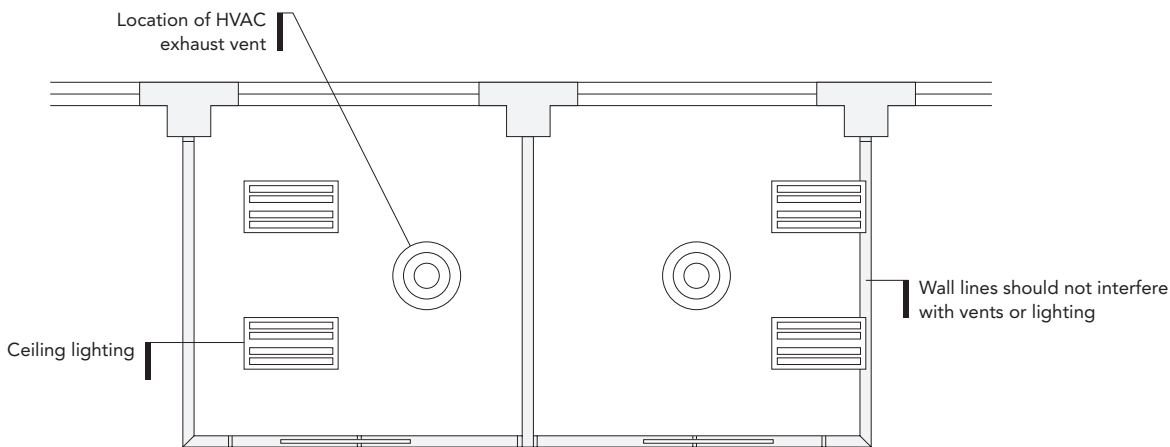

Table of Contents	15
Aspect Finishes	16
Aspect Panel & Trim Overview	17-35
Working with Seismic	17-21
Working with Product Tolerance & Field Measurements	22-25
Working with Site Requirements	26-30
Working with Panels & Trim	31-35
Aspect Panel & Trim Specifications	36-37
Frameless Glass & Vertical Fillers	36
Universal Trim	37
Aspect Door & Hardware Overview	38-49
Door and Hardware Matrix	38-40
Working with Doors	41-45
Working with Door Hardware	46-49
Aspect Door & Hardware Specifications	50-64
Sliding Doors	50-52
Pivot Doors	53-55
Hinged Doors	56-59
Door Hardware	60-64
Aspect Connector Overview.....	65-68
Working with Connectors	65-67
Working with Service & Touch Up Paint Kits.....	68
Aspect Connector Specifications.....	69-70
Wall Channels, Service Kit, & Touch Up Paint Kits.....	69
Drywall Endcap & Adapter	70

GLASS TYPES

FRAMELESS GLASS PANELS

1/2" Tempered Clear - Grade 1.....	HA
1/2" Tempered Low Iron - Grade 4.....	HB
1/2" Laminated Clear - Grade 2.....	HC
1/2" Laminated Low Iron - Grade 5.....	HD
1/2" Laminated High Performance Clear - Grade 3.....	HG
1/2" Laminated High Performance Low Iron - Grade 5.....	HH

FRAMELESS GLASS DOORS

1/2" Tempered Clear - Grade 1.....	HA
1/2" Tempered Low Iron - Grade 4.....	HB

FRAME FINISHES

PAINT COLOR SELECTION - GRADE 1

Black.....	P71
Brownstone.....	P7D
Bungalow.....	P7C
Cinder.....	P7Q
Cove.....	P096
Designer White.....	PJW
Dune.....	P094
Flint.....	P02
Fossil.....	P28
Harbor.....	P097
Loft.....	P7B
Muslin.....	P4J
Parchment.....	P93
Pebble.....	P8R
Pewter.....	P8D
Sage.....	P095
Salt.....	P8C
Textured Brownstone.....	P7J
Textured Charblack.....	XCBK
Textured Designer White.....	PK7
Textured Flint.....	P7A
Textured Loft.....	P7L
Textured Muslin.....	P7M
Textured Pebble.....	P8Y
Textured Salt.....	P8Z
Textured Titanium.....	P8V
Titanium.....	P8T

PAINT COLORS - GRADE 2

Champagne Metallic.....	PR5
Designer White High Gloss 65.....	P8W
Gunmetal Metallic.....	PR3
Matte Gold.....	P8G
Night Bronze.....	P8B
Pyrite.....	PJE
Silver.....	PR6
Solar Black.....	P8X

ANODIZED ALUMINUM

Satin Anodized Aluminum.....	SAL
------------------------------	-----

VENEER FINISHES

STRATAWOOD VENEERS - GRADE 2

Beigewood.....	SE878
Belair.....	SE934
Burnished Cherry.....	SC777
Clear Cherry.....	SC700
Clear Maple.....	SE800
Clear Rift Oak.....	SF300
Clear Silver Oak.....	SB100
Dark Rift Oak.....	SF331
Field Elm.....	SE599
Florence Walnut.....	ST579
Harvest Maple.....	SE856
Light Cherry.....	SC701
Light Walnut.....	ST601
Lowell Ash Cherry.....	SC394
Phantom Ecu.....	SE912
Pinnacle Walnut.....	ST679
Portico Teak.....	SB150
Shaker Cherry.....	SC774
Skyline Walnut.....	ST625
Sumatra Walnut.....	ST693

NATURAL VENEERS - GRADE 2

Burnished Cherry.....	NC777
Cinnamon/Biltmore Cherry.....	NC260
Clear Maple.....	NE800
Ebony Walnut.....	NT509
Florence Walnut.....	NT579
Harvest Maple.....	NE856
Light Cherry.....	NC701
Light Walnut.....	NT601
Lowell Ash.....	NC394
Medium Red Cherry.....	NC512
Nutmeg Walnut.....	NT629
Pinnacle Walnut.....	NT679
Shaker Cherry.....	NC774
Skyline Walnut.....	NT625
Sumatra Walnut.....	NT693

NATURAL VENEERS - GRADE 3

Dark Rift Cut Oak.....	RF331
Fawn Cypress Rift Cut Oak.....	RF108
Light Rift Cut Oak.....	RF301
Natural Recon.....	RF896
Phantom Ecu Rift Cut Oak.....	RF912

LAMINATE FINISHES

SOLID LAMINATES - GRADE 1

Black.....	P
Brownstone.....	LM13
Bungalow.....	LM12
Designer White.....	LDW1
Flint.....	LM16
Fossil Shale.....	LEH1
Loft.....	LM11
Muslin.....	LM15
Titanium.....	LT11

WOODGRAIN LAMINATES - GRADE 1

Belair.....	LWBA
Bourbon Cherry.....	H
Field Elm.....	LWFE
Florence Walnut.....	LFW1
Kingswood Walnut.....	LK11
NeoWalnut.....	LNU1
Pinnacle.....	PINC
Shaker Cherry.....	LW7C

WOODGRAIN LAMINATES - GRADE 2

Beigewood.....	LWBE
Fawn Cypress.....	LFC1
Lowell Ash.....	LLA1
Mangalore Mango.....	LMM1
Natural Recon.....	LNR1
Phantom Charcoal.....	LPC1
Phantom Ecu.....	LPE1
Portico Teak.....	LPT1
Skyline Walnut.....	LSW1
Veranda Teak.....	LVT1

WOODGRAIN LAMINATES - GRADE 3

Natural Walnut.....	LWNW
---------------------	------

PAINTED WOOD DOOR FINISHES

PAINT COLOR OPTION - GRADE 1

Black.....	P71
Brownstone.....	P7D
Designer White.....	PJW
Flint.....	P02
Fossil.....	P28
Loft.....	P7B
Muslin.....	P4J

POLYMERS

VERTICAL FILLERS

Clear Polycarbonate.....	CPC
--------------------------	-----

EXPOSED DOOR HARDWARE FINISHES

Silver.....	SIL
Black.....	BLK

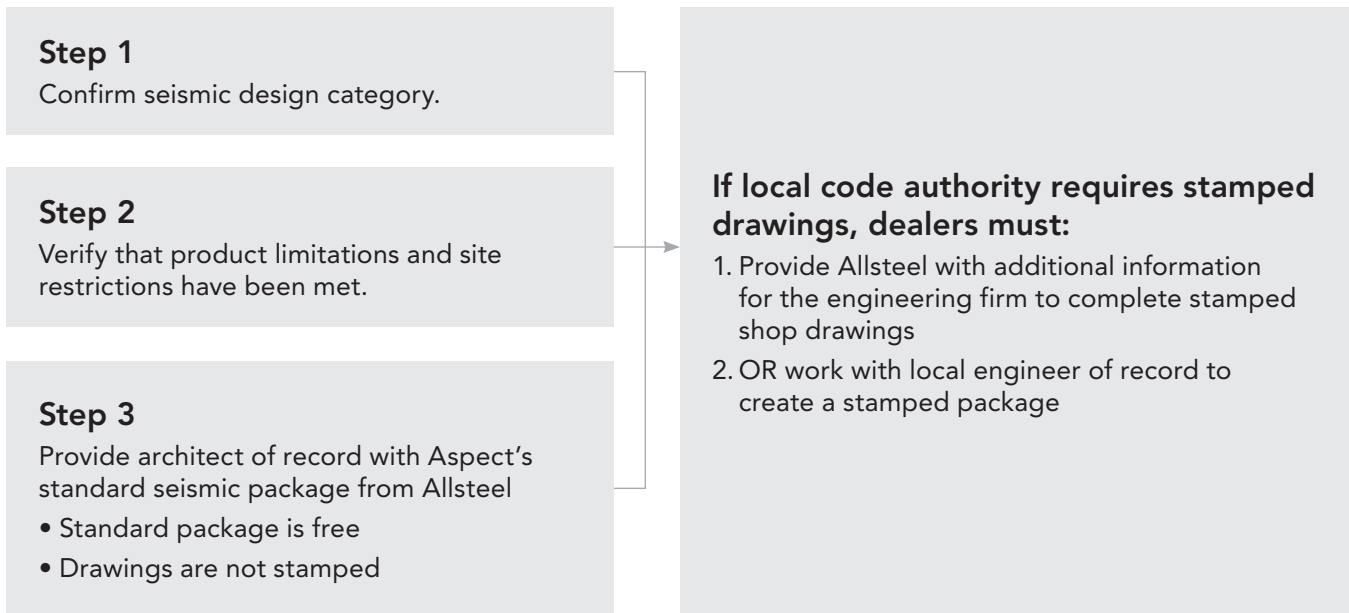

The project architect is ultimately responsible for code compliance including seismic requirements.

Allsteel has created guidelines regarding the sale and installation of Aspect in seismic zones. Before selling Aspect in a seismic zone, it's important to know which seismic zone the project is in as well as the building category. Aspect has been evaluated for seismic design categories C-F through a third-party engineering firm, where glass deflection was tested using computer analysis. Product installation is restricted to seismic risk categories I, II and III. Please consult the project architect for more details.

Please contact your Allsteel PM or Wall BDM with further questions.

Anchoring

There are no additional requirements for anchoring. See the Ceiling/Floor Connection Rules in the following pages for details.

Note: Aspect trim has centerlines at 15" centers, and a fastener needs to be placed in every pre-drilled hole.

Header Structure

Allsteel defers to the project architect and engineer of record for all building elements necessary to meet a project's seismic requirements. Structural soffits for Aspect should be designed with lateral loading and uplift vs. down load in mind in seismic zones.

Product Limitations

Aspect product limitations differ by glass type. There are no limitations regarding Aspect doors.

Tempered glass is the least restrictive. The only restrictions for tempered glass are on glass widths at 2-way and 3-way connections.

- At a 2-way connection, the sum of the width of two panels at the corner cannot be more than 64".
- At a 3-way connection, the sum of the width of the panel on either side of the return combined with the width of the return cannot be more than 64".

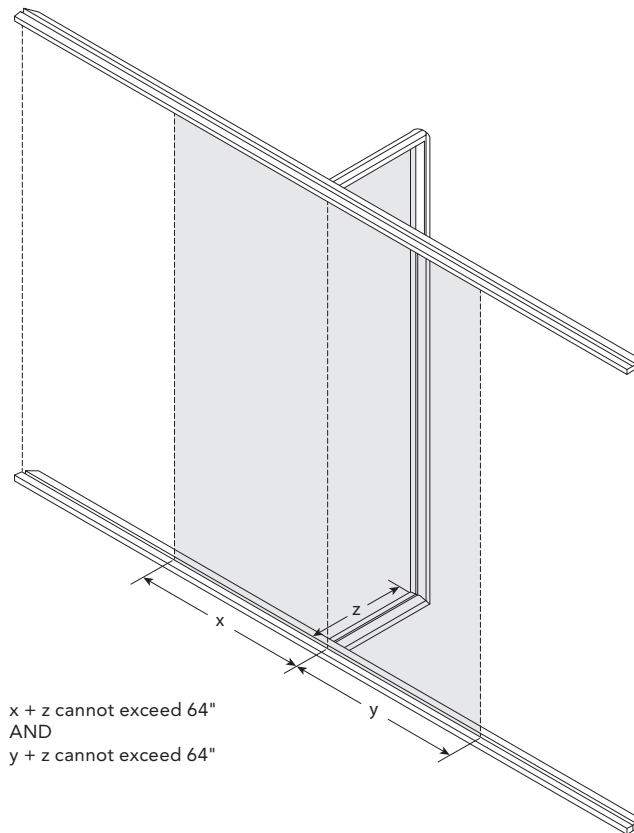
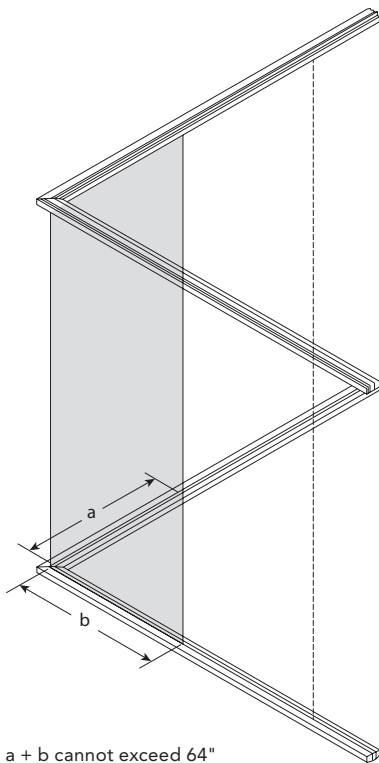

Laminated glass is more restrictive. Note that door placement can help mitigate restrictions as there are no limitations on Aspect doors.

Aspect cannot support corner applications (two-way or three-way connections) with laminated glass and is limited to straight runs only. These straight runs are limited in width to (2) pieces of 42" wide glass, or 84" in total width. Each laminated glass panel must be supported by ceiling track, floor track and at least one vertical trim component.

Laminated Glass runs in seismic zones are limited to (1) 42" wide glass panel maximum above 108" high. Please decrease wall length or switch to Tempered Glass.

Additionally, laminated glass must be structurally adhered to all three trim components using silicone. This requirement is needed for the walls to withstand seismic clearance based on calculated seismic drift. Without being structurally adhered to trim components, Aspect runs are limited to a single glass panel that is no more than 30" in width.

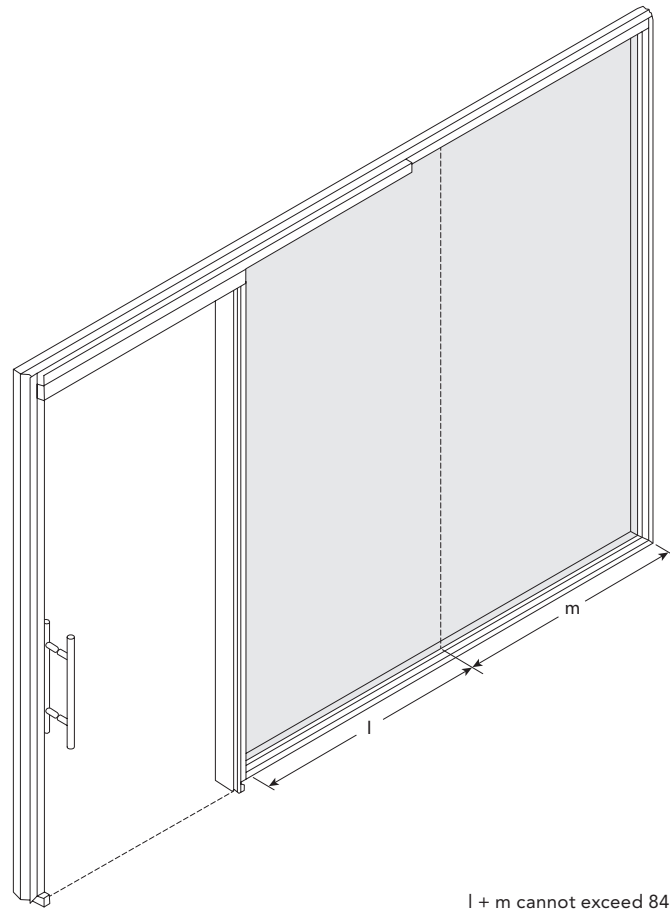

Documentation

Allsteel provides a standard seismic package for Aspect. This standard package is not stamped. There is no cost to obtaining this package and it is available on [our Website](#) or through your Allsteel PM. This package should be provided to the Architect of Record.

Upfront Proposal Pricing

In some situations, local code authorities may require additional documentation including stamped drawings. Below are two options for obtaining stamped drawings that may carry additional costs. Allsteel is not responsible for covering these additional costs. It is recommended that dealer partners include verbiage in their proposal to the customer that notifies the customer of the potential of these additional costs.

Option 1) Provide Allsteel with additional information for the engineering firm to complete stamped shop drawings. For a small fee, Rice Engineering can create site-specific stamped drawings. To receive site-specific stamped drawings, the dealer will need to provide the following details to the Allsteel Project Manager:

1. Project Name
2. Location (City and State)
3. Structural Notes if available
4. Specifications if available
5. Building Type (Hospital, Store, Office, School, etc.)
6. Final Shop Drawings and Bill of Materials: Include plan/elevation view and wall height
7. Optional: Substrates at the Head and Sill

Option 2) The engineer of record for the project can take site-specific calculations and incorporate these calculations into the package they submit.

Product Testing

Aspect Design Loads are in accordance with codes shown on Sheet No: "0" of the standard calculations package: 5 PSF / 50 PLF @ 42" A.F.F. (Standard calculations package is available on allsteeloffice.com. Contact your project manager or local sales person.)

Office Front Solutions Interior Partition Wall Calculations

Project Location: **Not Applicable** Prepared for: **Allsteel - Muscatine, IA**
 REI Project # **R17-02-220** S/25/2017

Design Criteria:

- Design Loads in accordance with codes shown on sheet 0: 5 PSF / 50 PLF @ 42" A.F.F.
- Glass Panels shall as shown in the calculations. Use **annealed minimum**.
- Aluminum mullions shall be alloy **6063-T5** or better. Members designed per the Aluminum Association, "Aluminum Design Manual".
- Deflection to be **L/75 or 1 1/2 max.** for glass panels.
- Steel anchor plates to be minimum **ASTM A-36 steel**.
- Steel Studs are assumed to be a minimum of **16 GA, Fy = 33 ksi minimum**.
- Screws and bolts shall be **stainless steel alloy groups 1,2 or 3 (300series only), condition CW Fy = 65 ksi, Fu = 110 ksi minimum** with diameters and locations as shown in calculations.
- Concrete anchors shall be a screw type anchor with the size, embedment depth and spacing as per the calculations. Anchors shall be installed per the manufacturer's specifications. Use **Redhead or equal**.
- Concrete strength is assumed to be **Fc = 3000 psi, cracked, and normal weight**.
- Design of material separation to prevent reaction between dissimilar materials **not designed by Rice Engineering Inc.**
- Tape to be as shown and installed per manufacturer's recommendations.
- Wood Screws shall conform to **ANSI/ASME Standard B18.6.1-1981, minimum bending yield strengths of Fby=70 ksi**, Lag Screws shall conform to **ANSI/ASME Standard B18.6.1-1981, minimum bending yield strengths of Fby=60 ksi**.
- Wood is assumed to be **Spruce-Pine-Fir, SG = 0.42**.
- Use **Full Bearing Shims** with dimensions as shown in the calculations.

Per IBC, glass has been designed using a safety factor of 4 in determining the allowable flexural stress (24,000/4 = 6,000 psi).
 Per IBC, glass panels need to be manufactured from an approved safety glazing material conforming to CPSC 16 CFR 1201 (ii).
 The glass manufacturer is responsible for providing acceptable safety glass conforming to IBC and CPSC provisions.

<p>Disclaimer:</p> <p>This Certification is limited to the structural design of structural components of this Interior Partition Wall system. It does NOT include responsibility for:</p> <ul style="list-style-type: none"> Structural design of hardware or support structure. Design of material separation to prevent reaction between dissimilar materials. Design of air and water infiltration prevention. The manufacture, assembly, or installation of the system. Quantities of materials or dimensional accuracy of drawings <p>Cover Page 1 of 2</p>	<p>Engineers Design Approval Stamp:</p> <div style="border: 1px solid black; padding: 10px; width: 150px; margin: 0 auto;"> <p>PRELIMINARY DESIGN NOT FOR CONSTRUCTION</p> </div>
--	--

Code Compliance and Disclaimers	Detail Ref.	Sheet No: 0
---------------------------------	-------------	----------------

APPLICABLE CODES

International Building Code (IBC) - 2003-2015 Alabama State - 2009 IBC Alaska State - 2009 IBC Arizona State - 2009 IBC Arkansas State - 2006 IBC California Building Code - 2016 Municipal Code of Chicago Colorado State - 2015 IBC Connecticut State Building Code - 2016 D.C. Construction Code - 2013 Delaware State - 2012 IBC Florida Building Code - 2014 with 2016 Supplement Georgia State - 2012 IBC Hawaii State Building Code Idaho State - 2012 IBC Indiana Building Code - 2014 Iowa State - 2015 IBC Kansas State - 2003 IBC Kentucky Building Code - 2013 Louisiana State - 2012 IBC Maine Uniform Building and Energy Code - 2009 Maryland State - 2015 IBC Massachusetts Building Code - 8th Edition Michigan Building Code - 2015 Minnesota Building Code - 2015 Mississippi State - 2015 IBC	Missouri State - 2012 IBC Montana State - 2012 IBC Nebraska State - 2012 IBC Nevada State - 2012 IBC New Hampshire State - 2009 IBC New Jersey Building Code - 2015 IBC with NJ Amendments New Mexico State - 2009 IBC New York State Building Code - 2015 New York City Building Code - 2014 North Carolina Building Code - 2012 North Dakota State Building Code - 2015 Ohio Building Code - 2013 Oklahoma Uniform Building Code - 2015 IBC Oregon Structural Specialty Code - 2014 Pennsylvania State - 2009 IBC Rhode Island Building Code - 2013 South Carolina State - 2012 IBC South Dakota State - 2015 IBC Tennessee State - 2006 IBC Texas State - 2006 IBC Utah Uniform Building Code - 2015 Vermont State - 2015 IBC Virginia Building Code - 2012 Washington State Building Code - 2015 West Virginia State - 2009 IBC Wisconsin Commercial Building Code - 2009 IBC Wyoming Building Code - 2015 IBC
--	--

ALWAYS CHECK WITH THE LOCAL JURISDICTION AS EACH CITY, COUNTY, OR STATE MAY HAVE DIFFERENT REQUIREMENTS

<p>Template:</p>	105 School Creek Trail Luxemburg, WI 54217 Phone: (620)617-1042 Fax: (620)617-1100 www.rice-inc.com	Project Description: Allsteel New Office Front Seismic Category A and B	Job No: R-17-02-220 Engineer: TLF Date: 3/1/17 Sheet No: 0 Rev: Chk By: Date:
------------------	---	---	---

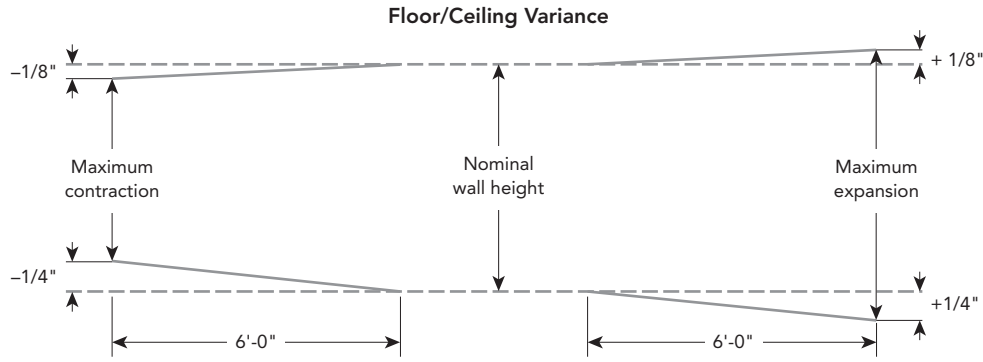

Floor

Aspect requires that the contractor adhere to a finished floor variation of $\pm 1/4"$ every 6'.

Note: Acceptable "flat" finished floor variation using straightedge method: $\pm 1/4"$ every 10'.

Ceiling

Aspect requires that the contractor adhere to a ceiling header variation of $\pm 1/8"$ every 6'.

Note: The Metal Lath/Steel Framing Association (ML/SFA) and the American Society of Testing Materials (ASTM) state under section C1007 that tolerances for steel framing horizontal alignment (levelness) of walls shall be within 1/960th (1/8" in 10') of their respective lengths.

Profile View

Side View

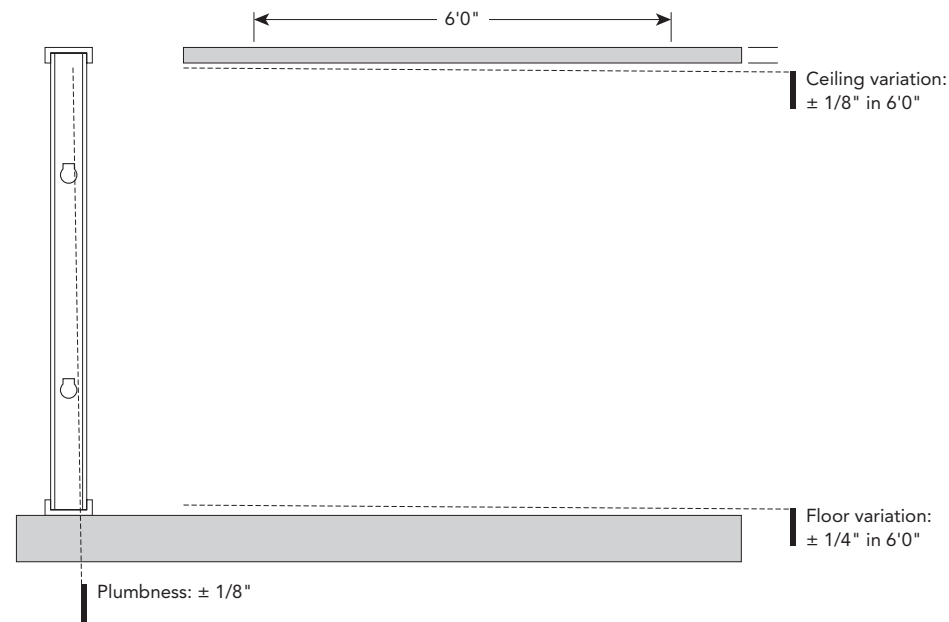

Wall Plumbness

Aspect requires the contractor adhere to vertical plumbness of $\pm 1/8"$ over 10'.

Note: Metal Lath/Steel Framing Association (ML/SFA) recommends acceptable gypsum wallboard plumbness of 1/8" in 10'.

It is recommended that measurements are taken from the benchmark to the floor and to the ceiling every 24" when using Aspect.

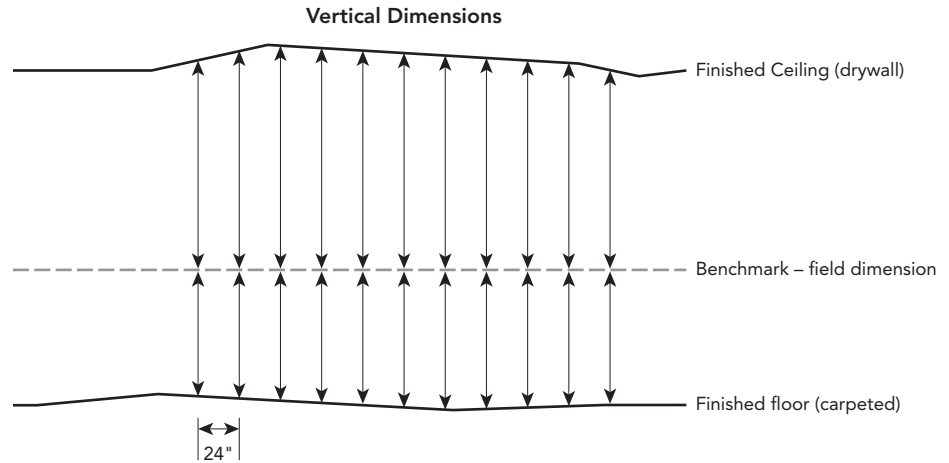

For horizontal dimensions, it is recommended that opening dimensions from finished drywall to finished drywall are taken when using Aspect.

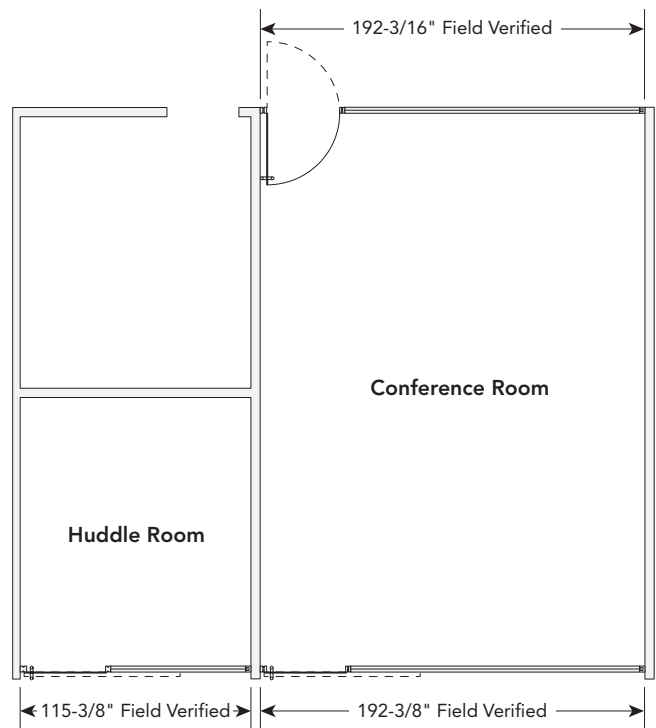

Allsteel APG Pre-Install Measurements

Project: _____

Date: _____

Room #	Vertical (facing office)	Finished Above BM	Finished Below BM	Horizontal FD Location	Finshed Dim	Swing Door - Vert	Notes
A	Left	65.250	34.500	Top	114.75	34.375	Pivot Door
	Center Left	65.250	34.375	Center	114.625	34.5	
	Center	65.250	34.375	Base	114.75		
	Center Right	65.250	34.250				
	Right	65.000	34.000				
			0.250	0.500		0.125	0.125
B	Left	66.250	33.500	Top	74.34		No Door
	Center Left	66.250	33.750	Center	74.25		
	Center	66.000	34.000	Base			
	Center Right	66.000	34.000				
	Right	65.875	33.250				
			0.250	0.750		0.09	
C	Left	66.000	33.500	Top	194.4375	33.125	Pivot Door
	Center Left			Center	194.4375	33.875	
	Center	66.125	33.625	Base			
	Center Right						
	Right	66.250	34.000				
			0.250	0.500		0	0.65

BM = Default is Bench Mark is reset at each office

Finished = Examples include carpet at floor & painted drywall at header and side wall

Green: Within **Aspect** tolerance

Red: Not within **Aspect** tolerance

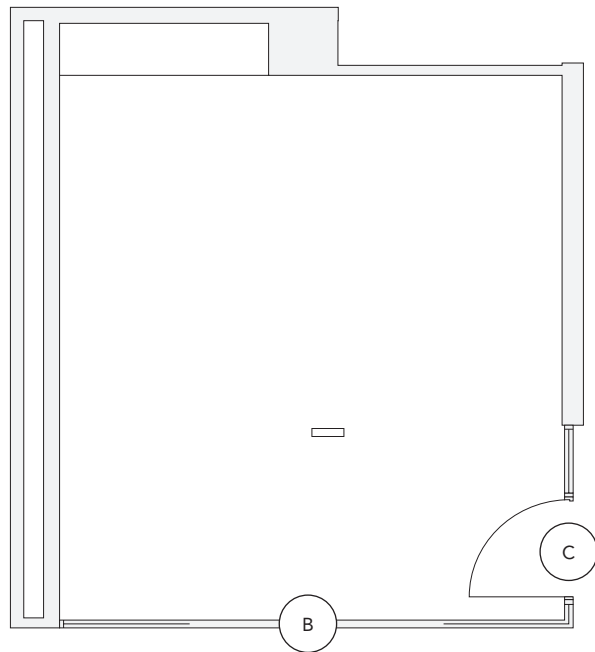
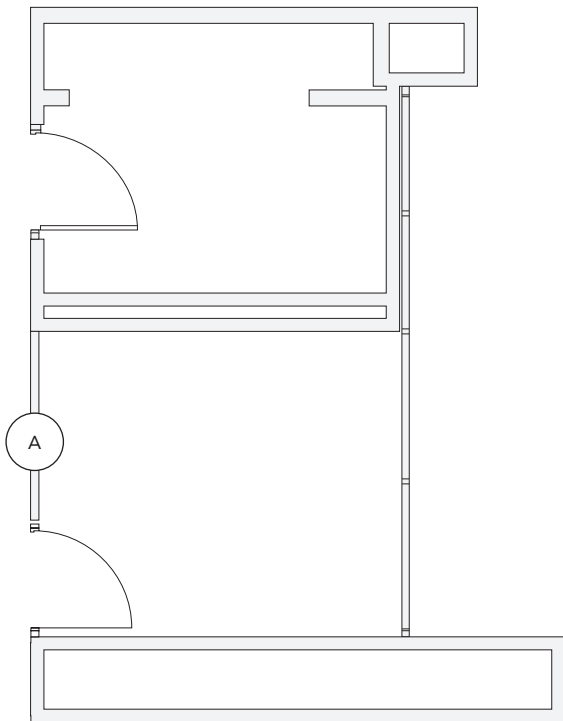

Ceiling and Floor Levelness

1. Review areas outside of **Aspect's** floor levelness tolerance with the general contractor following field dimensions.
2. Obtain time line for completion of corrective action from general contractor, factor potential delay into overall project schedule, and communicate to appropriate parties.
3. Confirm results of resolution on site to agreed-upon date.

Construction Vertical Partition Plumbness

1. Review areas outside of **Aspect's** vertical construction partition tolerance with the general contractor following field dimensions.
2. Obtain time line for completion of corrective action from general contractor, factor potential delay into overall project schedule, and communicate to appropriate parties.
3. Confirm results of resolution on site on agreed-upon date.

Requirements for a Steel Bulkhead

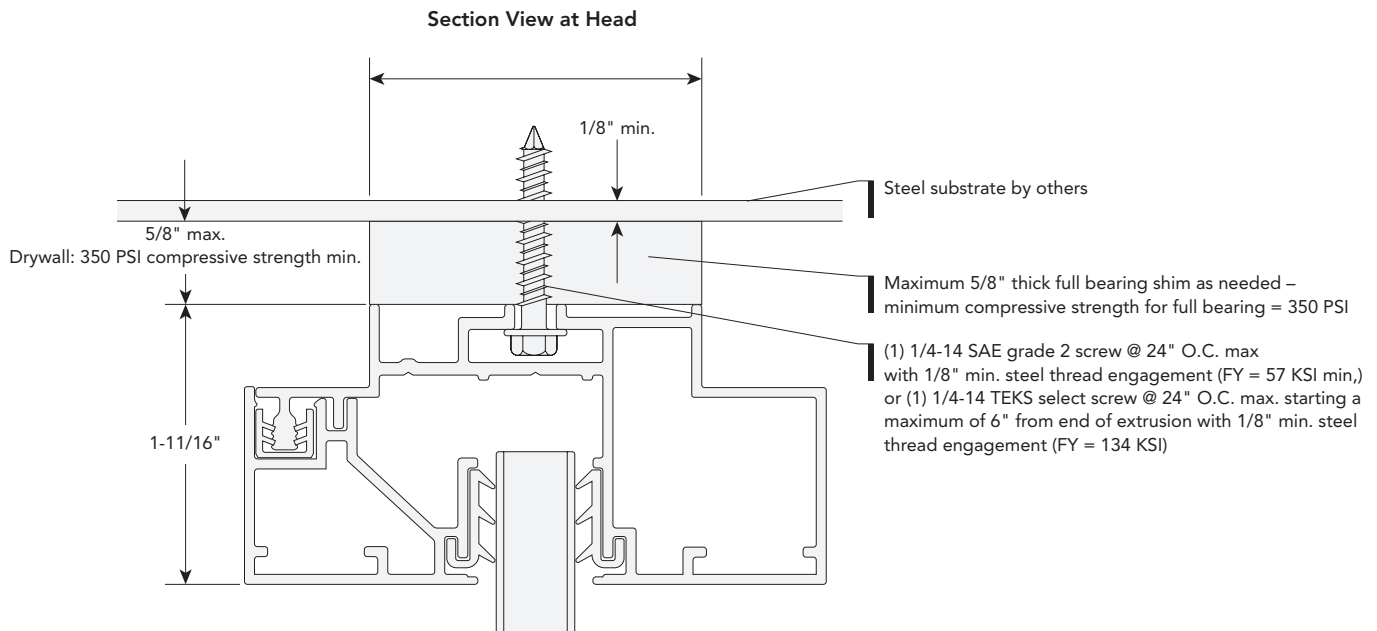

Note: Anchors supplied by installation partners.

Requirements for a Metal Stud Bulkhead

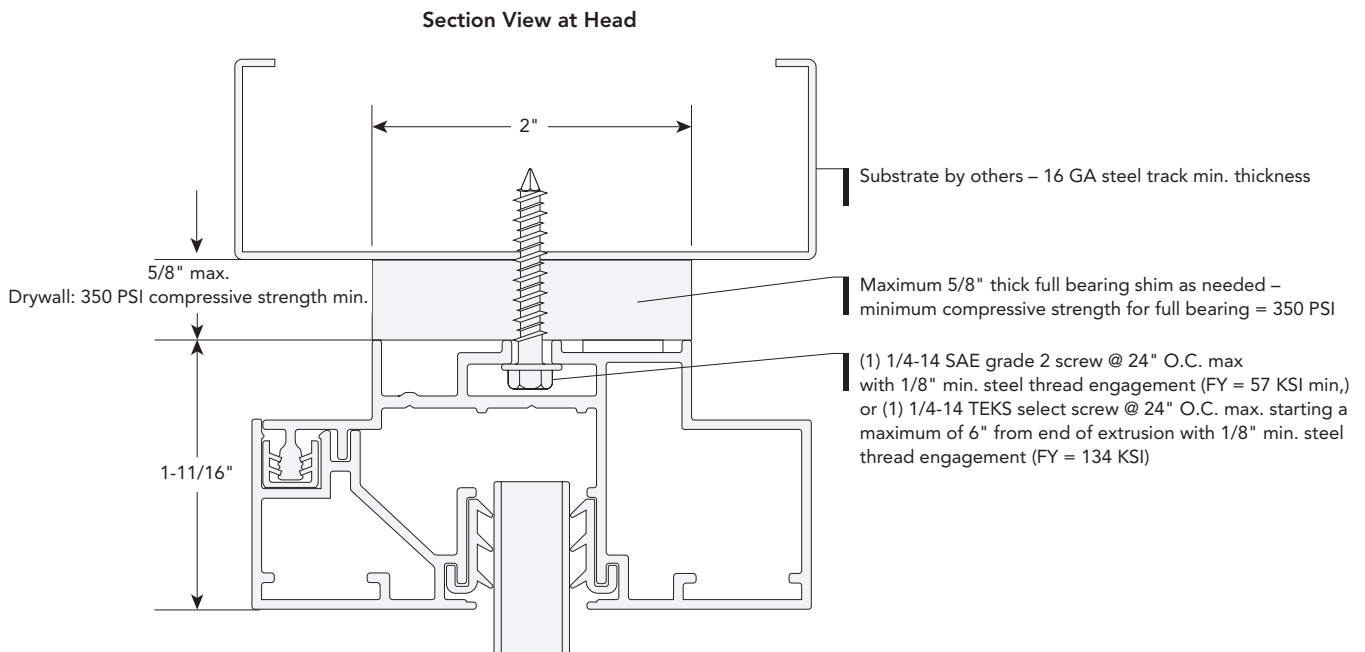

Note: Anchors supplied by installation partners.

Requirements for a Wood Bulkhead

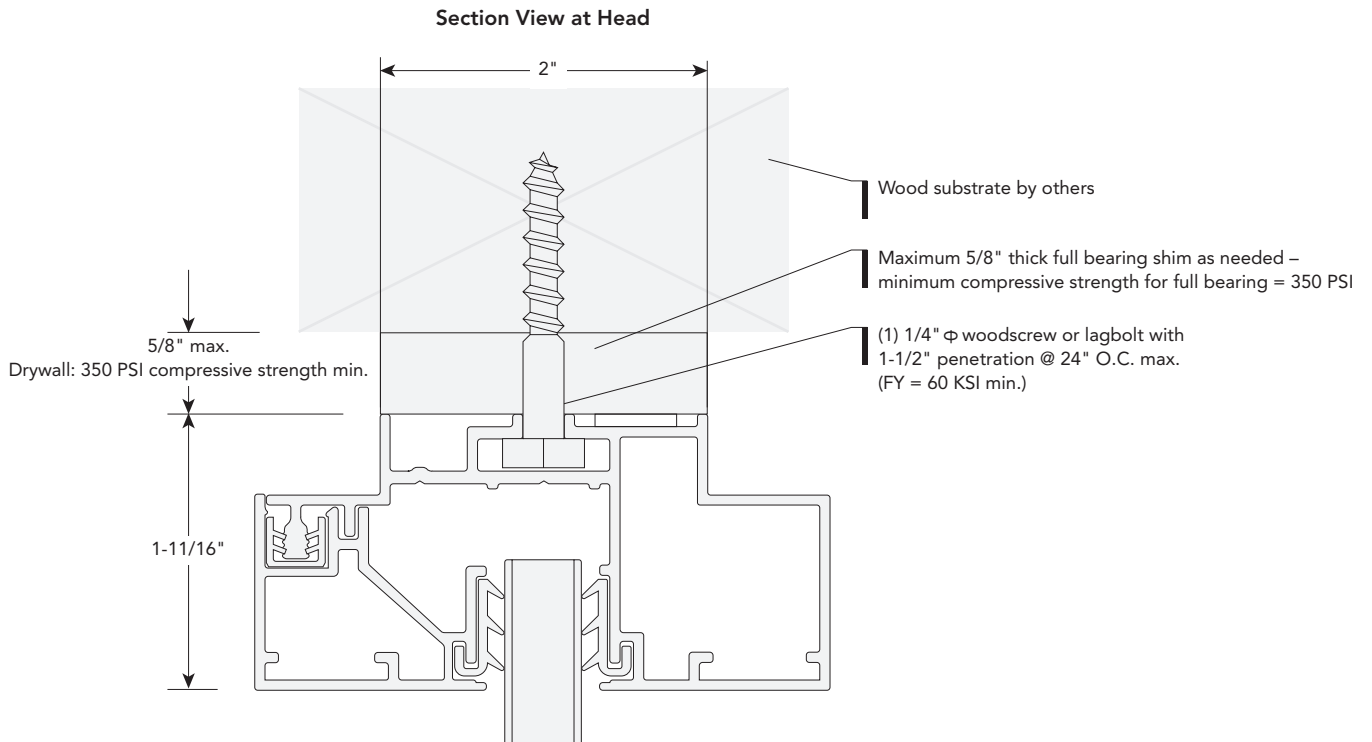

Requirements for a Wood Floor

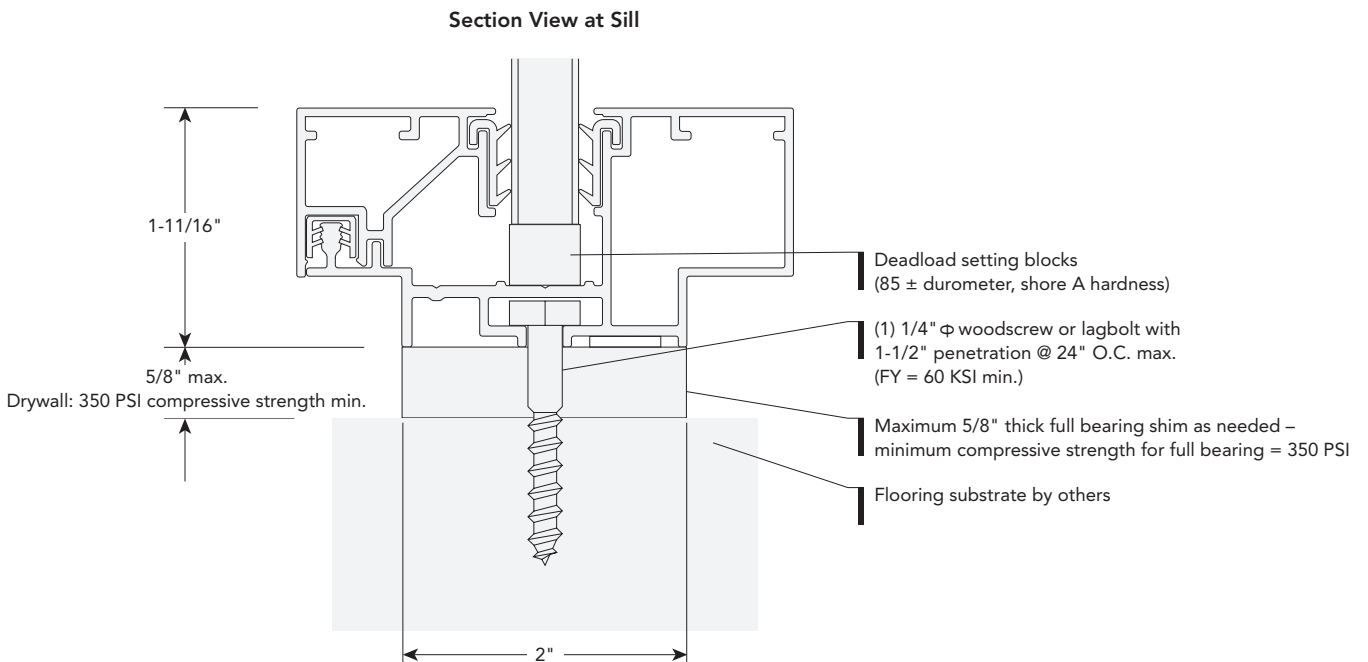

Note: Anchors supplied by installation partners.

Requirements for a Concrete Floor

Section View at Sill

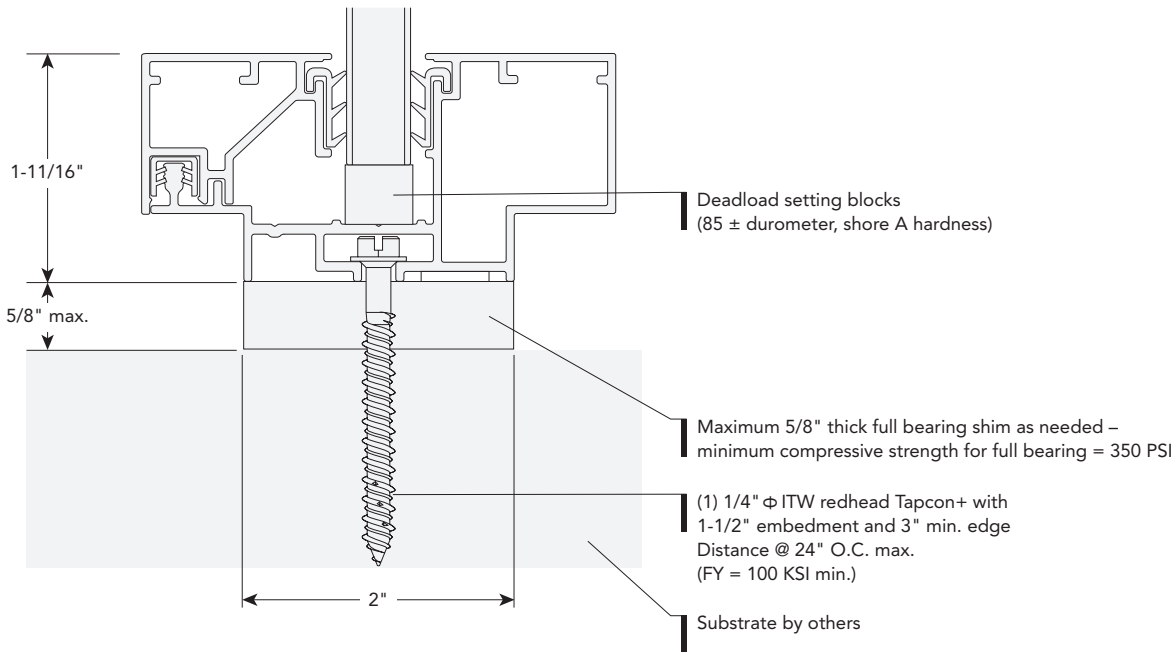

Note #1: Anchors supplied by installation partners.

Note #2: For post tension concrete applications, please consult with the architect prior to specifying.

ASPECT
TABLE OF CONTENTS

ASPECT
FINISHES

ASPECT
PANELS & TRIM

ASPECT
DOORS

ASPECT
CONNECTORS

Requirements for a Sliding Door

For Aspect sliding doors, headers/soffits should be built with minimum requirements in mind. Reference dimensions are not required.

Minimum bulkhead structure requirements for Aspect sliding door, except for Thin Frame Aluminum sliding door.

Allsteel recommends the removable portion of trim be oriented to outside of room and sliding doors always be placed on inside of room.

The sliding door should be placed opposite the side of the removable trim.

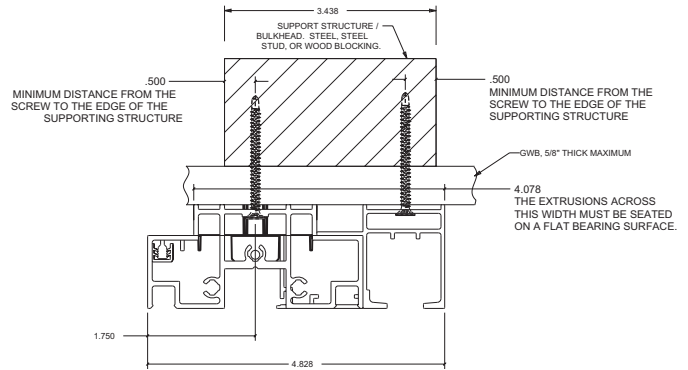

Application Example

Sliding door visualized in front edge to soffit condition with reference dimensions.

Minimum bulkhead structure requirements for Aspect Thin Frame Aluminum sliding door.

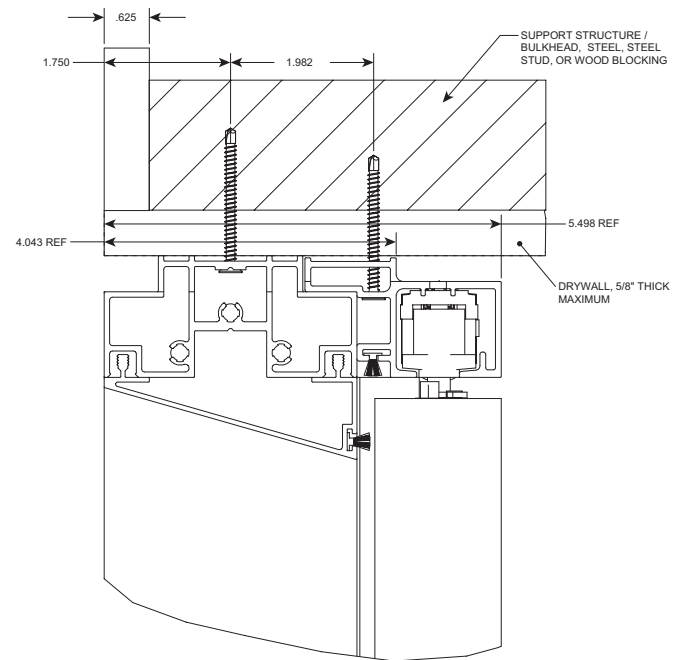
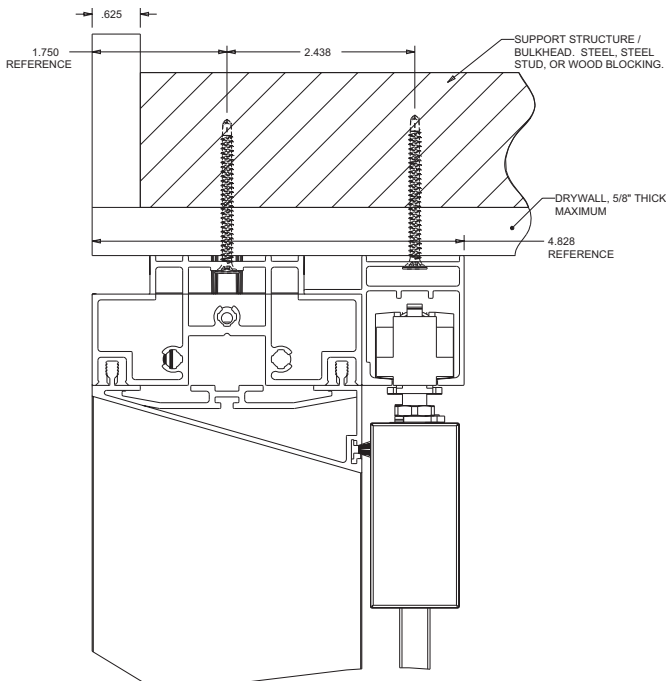

Aspect requires the header/soffit/bulkhead to be designed to support the weight listed below.

Ceiling Height	Door Type	Single or Double	Door Unit Width (inch)	Approx. Aluminum weight supported by header per foot	Door Leaf Type	Door Leaf Glass Thickness (inch)	Approx. Weight of Door Leaf
120	Slider	Single	42	1 to 2 lbs/foot	Glass	0.375"	172 lbs.

Note: Stand-alone glass units and center swing pivot doors need to support the weight of the aluminum only at the header or approximately 1 to 2 lbs/foot. The center swing pivot door's weight is dispersed to the floor. Hinged doors are supported through the vertical which takes load to floor.

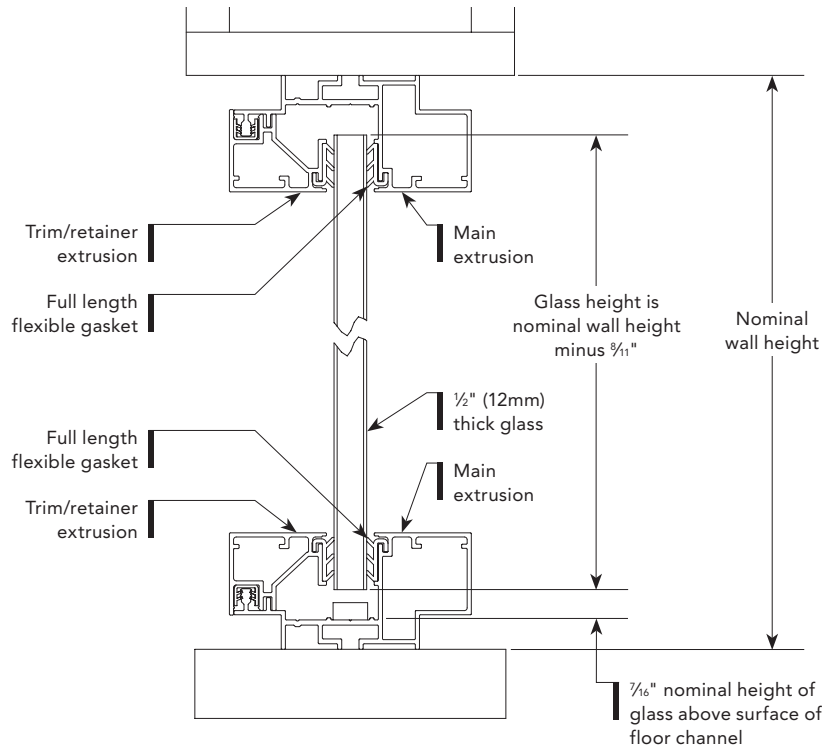

Frameless Glass

- Panel Dimensions
 - Height
 - 18"–120" in 1/16" increments
 - Width
 - 8"–42" up to 120"H in 1/16" increments
 - 42 1/16"–48"W up to 108"H in 1/16" increments
 - Glass Thickness
 - 1/2"
- Applications
 - 1, 2, 3, and 4-sided applications
 - Product designed for office front or conference room walls. Panels are anchored into the floor and ceiling and the weight of the doors is supported at the ceiling. Product designed to fit under a drywall soffit. Blocking required to support the weight of the doors.
 - Refer to the Pre-Specification guide for building requirement details.

- General overview
 - Universal two-piece trim at 1 1/16" high captures the glass at the top, bottom and at wallstarts
 - Corner block pieces lock horizontal and vertical trim elements together, creating clean corner connections and maintaining a continuous reveal. The continuous reveal is a unique aesthetic element that creates a look of windows between spaces
 - Trim is removable to allow front loading of glass and ease of leveling
 - Panels are leveled through adjustment of setting blocks (shims)
 - Base trim remains flush with the floor for a clean aesthetic because glass is leveled inside base trim
 - Aspect laminated glass panels are available with no additional upcharge over tempered glass. Laminated glass panels have a 36 STC rating for a fully assembled panel. Option to upgrade to 39 STC rating for a fully assembled panel with a high performance interlayer.

Glass Information and Acoustical Performance

Aspect glass comes in a variety of thicknesses and opacities. All Aspect glass meets ANSI Z97.1 safety glass standard. Different types of glass can be specified to boost acoustic properties, add visual privacy, or create an artistic look.

Glass Thickness Options

- Frameless: ½"

Glass Types

- Tempered glass is one sheet of heat-treated safety glass.
- Laminated annealed glass is made of up two pieces of heat-treated safety glass that are secured together. Laminated glass boosts acoustic properties and typically carries a higher STC rating.
- Performance or high acoustic laminated glass further boosts acoustic properties. A thin, transparent film is placed between the sheets of laminated glass that reduces sound travel and gains additional STC points.

Glass Colors

- Clear glass has a slight greenish hue when glass is viewed from the edges or side profile.
- Low iron glass is ultra-clear and of higher transparency and clarity than clear float glass. Generally, the green hue of the glass is reduced. It is typically more expensive than clear float glass.
- Translucent white laminated has a medium light transmission level of 65%, meaning it's semi-transparent.
- White markerboard laminated has a low light transmission level of 10%, meaning it's nearly opaque. The lower the light transmission level, the more difficult it is to see through the glass.

Acoustical Performance

Glass Panels	STC Result
½" Laminated Glass	36
½" Laminated Glass, High Performance	39

STC test results represent testing of a fully assembled panel.

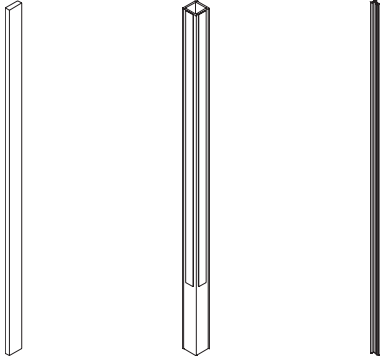

Vertical Fillers for Glass

- Description:
 - QTY 1 at each connection
 - Always comes in 120" lengths
 - Must be cut in field
 - Three types of connections
- Straight (Inline Application):
 - Clear VHB tape at inline connections
 - Use between glass panels in a straight run
- 2-Way (90-Degree Application):
 - Clear polycarbonate filler
 - Use between glass panels at 90-degree corner connections
- 3-Way (Three-Way Application):
 - Clear polycarbonate filler
 - Use for glass panels that intersect at a three-way intersection such as for set-back panels or glass demising walls
 - **CET adds 10% to vertical filler quantity for scrap.**

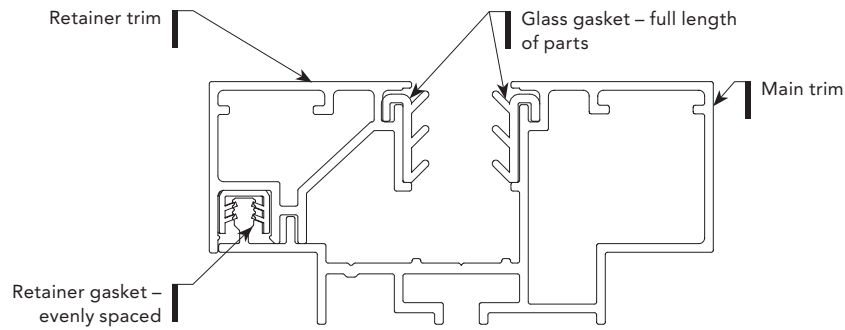

Universal Trim

- Universal two-piece trim
 - Comprised of a main trim piece and a retainer trim piece.
 - Two pieces are connected with a retainer gasket.
 - Trim captures the glass at the top, bottom and at wallstarts.
- Dimensions
 - 1¹/₁₆" tall
 - 3¹/₂" wide
 - 1/2" reveal
 - Straight trim comes in 120" lengths.
 - Two-way and three-way trim comes pre-mitered on both sides for ease of install.

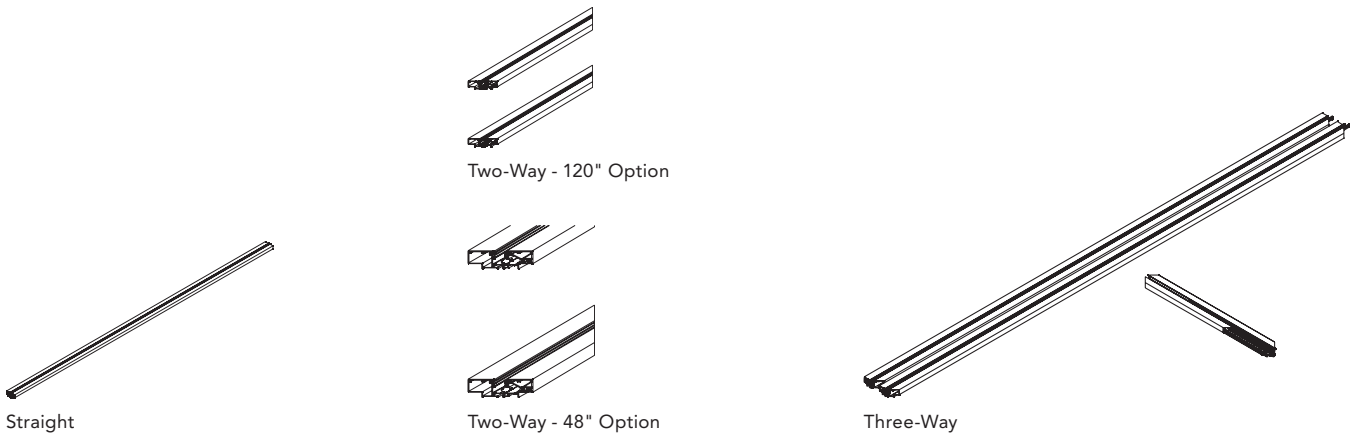

Universal Trim

- Straight: 120" lengths only
 - Order QTY (1) for top
 - Order QTY (1) for bottom
- Two-Way: 48" and 120" options
 - Order QTY (1) for top and bottom, one side (contains 2 sets of trim)
 - Order QTY (1) for top and bottom, other side (contains 2 sets of trim)
- Three-Way:
 - Order QTY (1) for top which includes
 - 120" for main run, top (contains 2 sets of trim)
 - 36" for demising wall, top
 - Order QTY (1) for bottom which includes
 - 120" for main run, bottom (contains 2 sets of trim)
 - 36" for demising wall, bottom

Leveling

- Panels have +/- 1/4" adjustment over 6 ft.
- To level panels, setting blocks are placed in the base channel.
- See Aspect Installation Guide for details.

Setting Blocks (Shims)

- Trim is removable to allow front loading of glass and ease of leveling. Panels are leveled through adjustment of setting blocks (shims).
- Base trim remains flush with the floor for a clean aesthetic because glass is leveled inside base trim.
- Need QTY (1) AS-INSTALLKIT per 200 LF
- Installation Kit
 - Contains setting blocks (shims) for leveling in the following sizes and quantities:
 - Glass Setting Block 1/16 – QTY 100
 - Glass Setting Block 1/8 – QTY 100
 - Glass Setting Block 1/4 – QTY 100
 - Glass Setting Block 3/8 – QTY 100
 - Nominal position for Aspect is using the 1/16 and 3/8 setting blocks to add up to 7/16

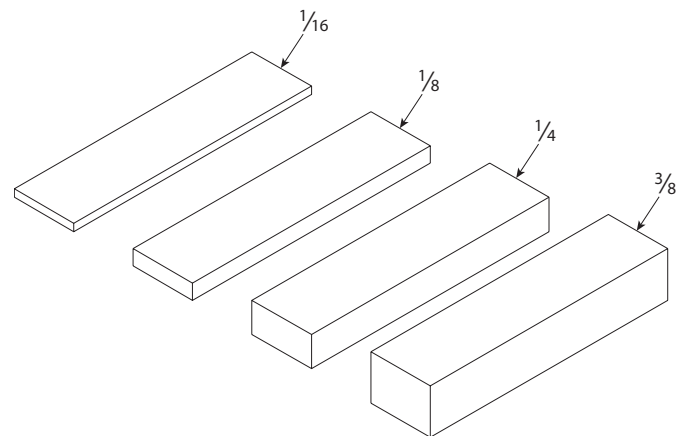



Frameless Glass Panel, Tempered

Base Model	Description	Specification
AS-SGFRMLSTPANEL	Frameless Glass Panel, Tempered	AS-SGFRMLSTPANEL
Configuration ID	Specification Description	
Product	Aspect	
Width	8"-42" in 1/8" increments up to 120"H 42 1/8"-48"W up to 108"H in 1/8" increments	
Height	18"-120" in 1/8" increments	
Glass code	HA: 1/2" Tempered Clear HB: 1/2" Tempered Low Iron	

Specification Example: AS-SGFRMLSTPANEL.#####



Frameless Glass Panel, Laminated

Base Model	Description	Specification
AS-SGFRMLSLPANEL	Frameless Glass Panel, Laminated	AS-SGFRMLSLPANEL
Configuration ID	Specification Description	
Product	Aspect	
Width	8"-42" in 1/8" increments up to 120"H 42 1/8"-48"W up to 108"H in 1/8" increments	
Height	18"-120" in 1/8" increments	
Glass code	HC: 1/2" Laminated Clear HD: 1/2" Laminated Low Iron HG: 1/2" Laminated, High Performance Clear HH: 1/2" Laminated, High Performance Low Iron	

Specification Example: AS-SGFRMLSLPANEL.#####



Straight

Base Model	Description	Specification
AS-FGFILLER	Vertical Filler	AS-FGFILLER
Configuration ID	Specification Description	
Product	Aspect	
Dimension	120"	
Trim Type	Vertical Filler	
Trim Use	Straight – note: material is VHB tape at straight connection Two Way Three Way	
Finish Color	See below	

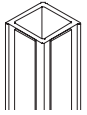

Two Way

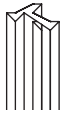

Three Way

Option	Specification Description	Specification
Vertical Filler Selection	Clear Polycarbonate	CPC

Specification Example: AS-FGFILLER.#####.CPC

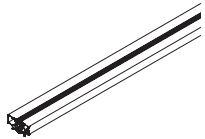

Straight



Two Way

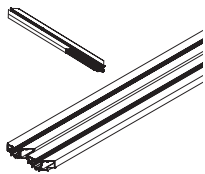

Three Way

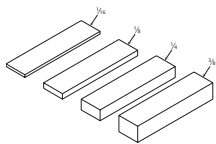

Base Model	Description	Specification
AS-SGU2PCTRIM	Universal Two-Piece Floor and Ceiling Trim	AS-SGU2PCTRIM

Configuration ID	Specification Description
Product	Aspect

Dimension	120" – Straight, Three Way 48", 120" – Two Way
-----------	---

Trim Type	Single Pane
-----------	-------------

Trim Use	Straight Two Way Three Way
----------	----------------------------------

Finish Color	Painted or Anodized Finishes
--------------	------------------------------

Option	Specification Description	Specification
Paint Color Selection	3-digit painted or anodized finish	See Aspect Frame Finishes

Specification Example: AS-SGU2PCTRIM.#####.P8X

Base Model	Description	Specification
AS-INSTALLKIT	Installation Kit	AS-INSTALLKIT

Specification Example: AS-INSTALLKIT

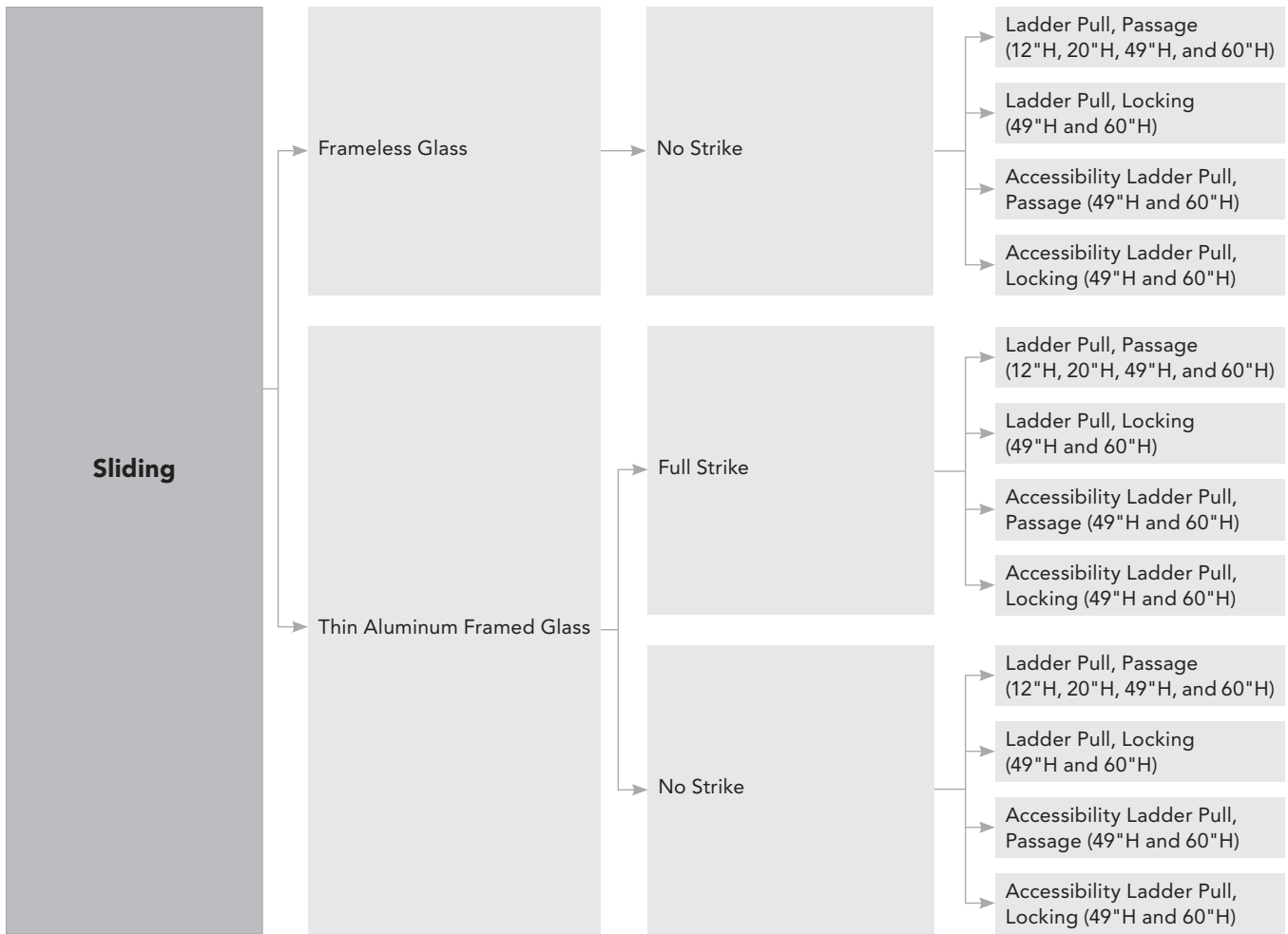

Continued on next page

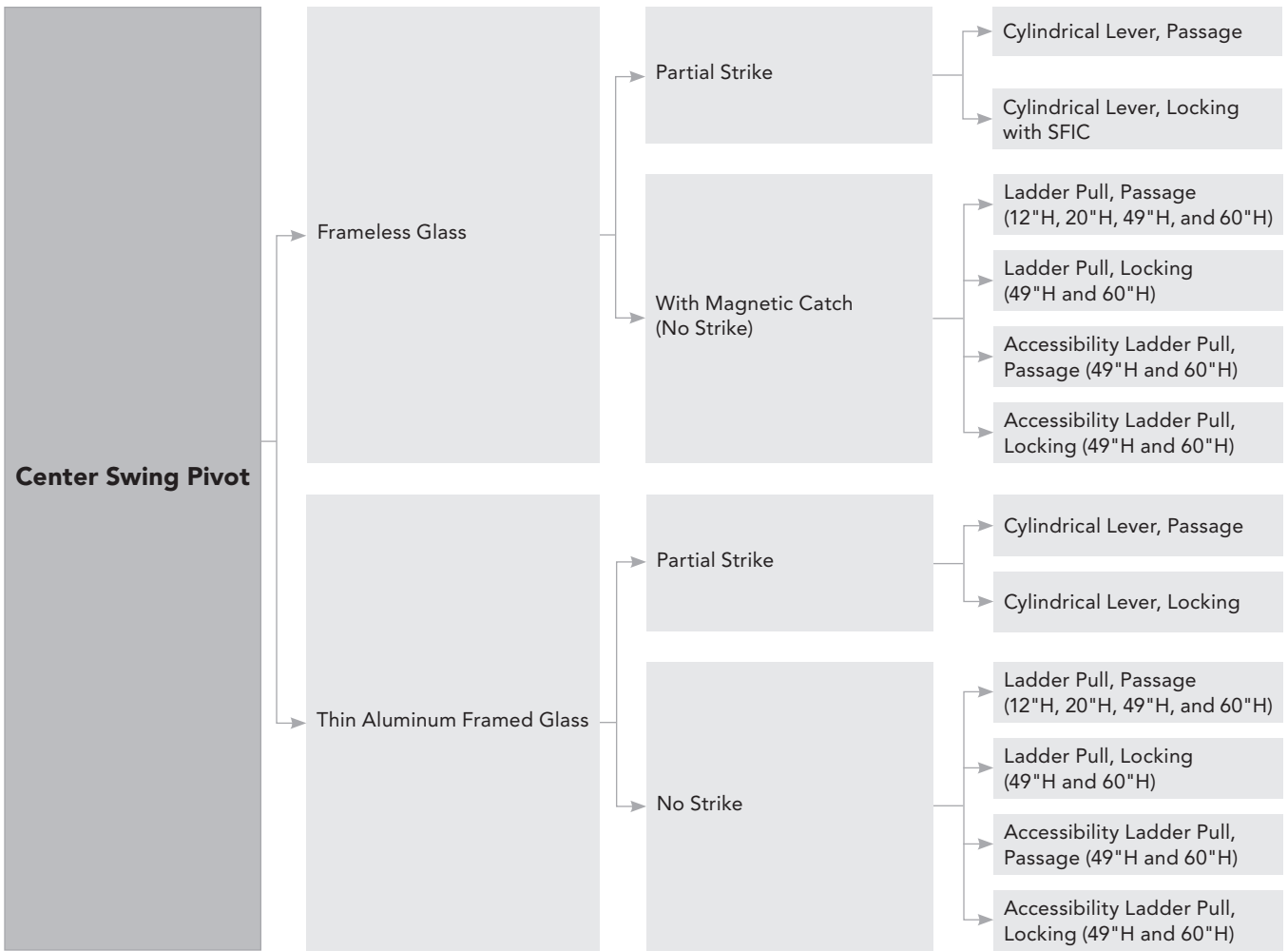

Continued on next page

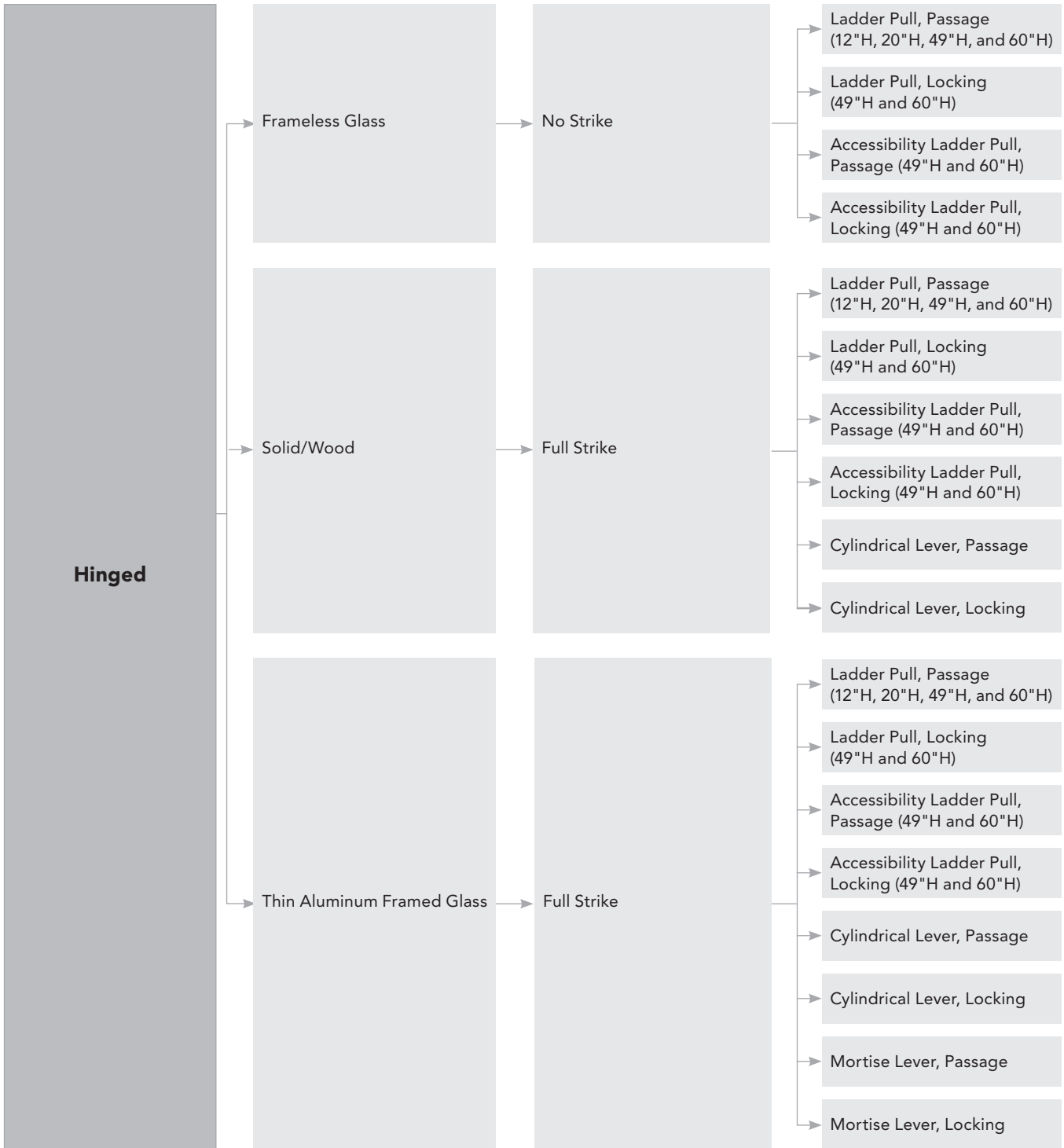

Sliding Doors

Sliding doors (single and double) require a 6" header. Blocking is required above the header to support the weight of the door. Please see pages [17-30](#) for more details.

General Information

- Sliding doors should be mounted on the interior of the office for a better aesthetic and for ease of installation.
- Frameless glass sliding doors come in nominal 42" modules for single doors and nominal 78" modules for double doors.
- Thin aluminum framed sliding doors come in nominal 42" or 48" modules for single doors and nominal 78" modules for double doors.
- Door frames only come in 120" lengths vertically and are cut to size in the field.
- Sliding door mounting hardware is included with the sliding door frame for both single and double doors.
- For double sliding doors, specify double door models and frames.
- Adjacent glass panels of the following dimensions are required next to sliding doors to support the door track and to eliminate interference with another panel or door:
 - 42" door module requires a 36"W minimum adjacent panel.
 - Clearance is 33¹⁵/₁₆".
 - 78" door module requires a 33¹/₂"W (33.5") minimum adjacent panel on both sides of the door.
 - Clearance is 63¹/₂" (63.5").
- Sliding door tracks are available in two options.
 - Standard (Single Doors Only)
 - Slow Close/Slow Open (Single or Double Doors)
 - Incorporates a motion-dampening mechanism to support soft closures and openings for sliding doors.

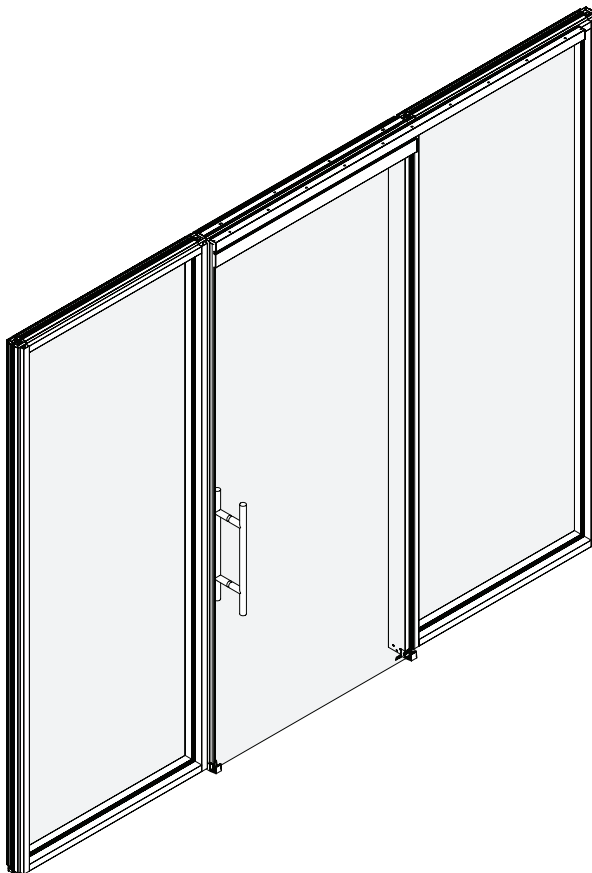

Single Sliding Door

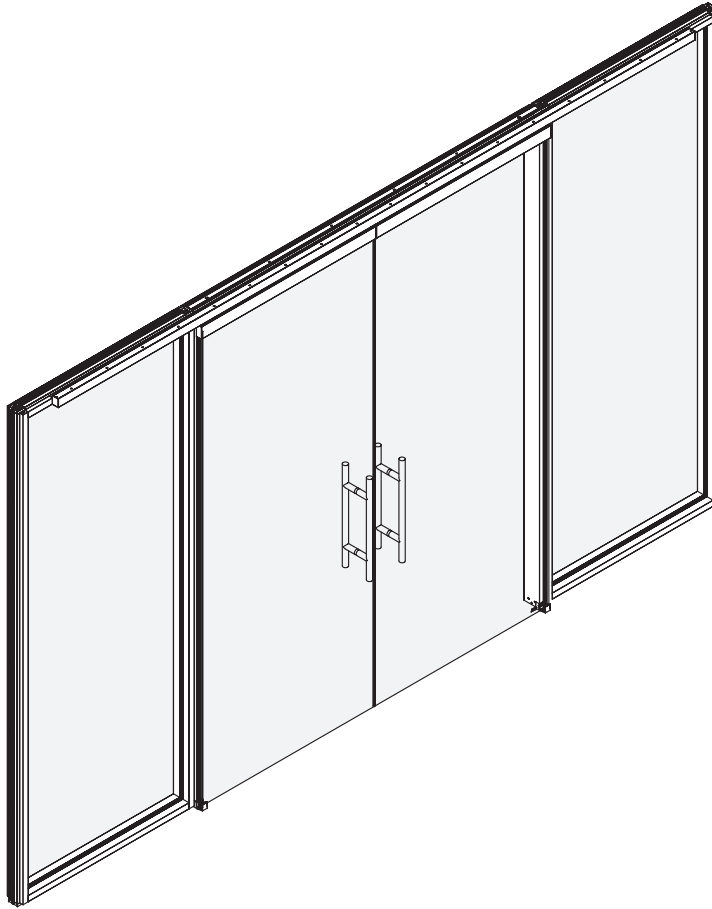

Double Sliding Door

- A rubberized leading edge seal is included with each door frame. The seal creates an acoustic barrier between the door and the door frame.
- Interlocking trailing edge seals are included with each frameless sliding glass door. Seals create added acoustic barriers.

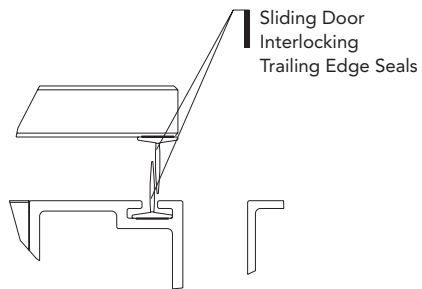

- Trailing edge seal is field-applied to the trailing edge of the frameless glass door. This seal interlocks with the trailing edge seal on the door frame.
- Sliding doors are non-handed.

Pivot Doors

- General Information:
 - All single center swing pivot doors utilize a nominal 39" door module.
 - Door frames are available in partial strike.
 - All double center swing pivot doors utilize a nominal 75" door module. Note: Only thin aluminum framed center swing pivot doors are offered in a double module, frameless glass doors are not.
 - The strike plate for partial strike door frames can be reversed, allowing the door frame to be non-handed.
 - Allsteel's center swing pivot door housing can be specified with a passage (non-locking) cylindrical lever, and a locking lever with a standard format interchangeable core (SFIC). SFIC locking is available for field-keying to building requirements and locks with a 7-pin SFIC push-button lock.
 - The pivot lever housing can accommodate other manufacturers' cylinder-style locks as a custom option.
 - Center swing pivot frameless doors can be specified with ladder pulls. The specification needs to include a magnetic catch and the corresponding door frame and door models.

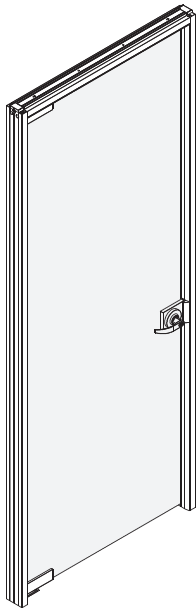

Frameless Glass Hinged Doors

- General Information
 - Single option.
 - Single frameless glass hinged doors utilize a nominal 39" module including the frame.
 - Door frames are non-handed.
 - Doors swing 90 degrees both inward and outward. An optional strike bracket can be installed to prevent the outward or inward swing of the door.
- Hydraulic hinges provide self-closing mechanism.
 - Automatic closing from 0 to 80 degrees.
 - Adjustable closing speed.
 - Stops at +90- or -90-degree open position.
- Utilize ladder pull options for door hardware. See the [Hinged Door Hardware pages of the Doors section](#) for details.
- Frameless glass hinged doors can be locked by specifying the locking ladder pull options.
 - The frameless glass center swing pivot door levers may also be used as a custom hardware and custom door frame option to provide additional locking options for frameless glass hinged doors.

Solid Hinged Doors

- Available in single and double door options.
- Single doors utilize a nominal 39" module including the frame. Double doors utilize a nominal 75" module including the frame.
- Available in veneer, laminate and painted wood.
- Door frames incorporate a full height strike for the door and are handed for both single and double doors.
- Double doors require specifying an active door.
 - The active door opens and closes with a lever.
 - The inactive door utilizes a flush bolt latch connecting into the door frame to lock out swing. Disengage latch to open the door.
 - The inactive door also incorporates an astragal for the active door to close against and provides a seal against light and sound between the doors.
- Door levers are available in the following options. See the Hardware pages of the Doors section (pages 46-49) for details.
 - Passage
 - Locking with SFIC

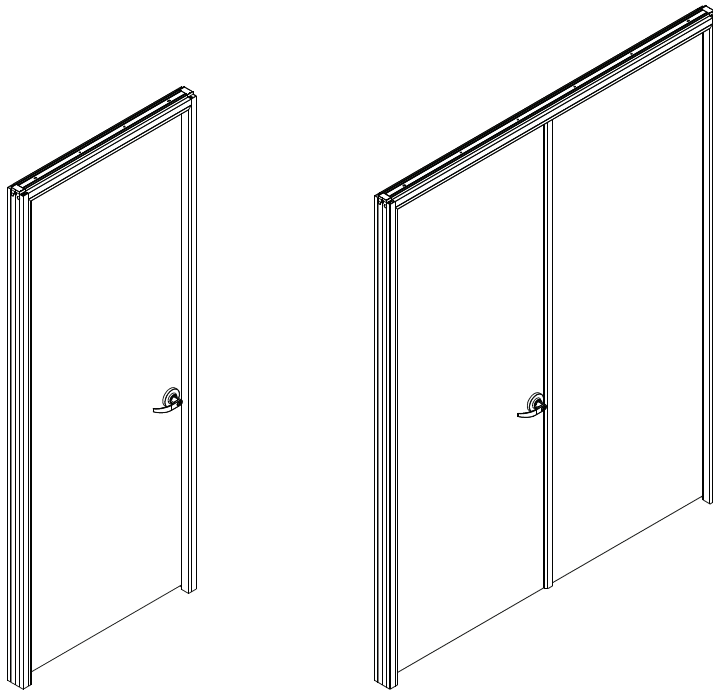

Single Solid Hinged Door

Double Solid Hinged Door

- Allsteel believes there are benefits in guaranteeing environmental and social responsibility. For this reason, all materials can be ordered with FSC (Forest Stewardship Council) Certification, ensuring that products have come from a forest and supply chain that is managed responsibly. Allsteel offers this benefit at no extra charge to consumers.

Door Hardware

All door hardware may be specified in silver or in black.

Ladder Pulls

- Use with sliding, center swing pivot / hinged frameless and thin framed glass doors.

12"H Ladder Pull

- ¾" (.75") diameter pull
- Stainless steel finish
- Passage (non-locking) only



12"H Value Ladder Pull

- 1" diameter pull
- Stainless steel finish
- Passage (non-locking) only



20"H Ladder Pull

- 1" diameter pull
- Anodized finish
- Passage (non-locking) only

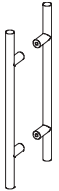

49"H Ladder Pull

- 1⅜" diameter pull
- Anodized finish
- 49"H Ladder Pull offered as either standard or accessibility, with accessibility pulls featuring an asymmetrical design with intent of supporting ADA building code, see page 47 for more details
- Passage option
- Locking option
 - Thumb-turn deadbolt lock is received into a floor socket
 - Rim cylinder with SFIC format
 - SFIC core for field-keying to building requirements
 - Best E keyway
 - Random keying
 - Use SFIC for any custom keying requirements
 - LFIC and other RIM cylinders are available as a custom option
 - Master keying is available by others

60"H Ladder Pull

- 1⅜" (1.375") diameter pull
- Anodized finish
- 60"H Ladder Pull offered as either standard or accessibility, with accessibility pulls featuring an asymmetrical design with intent of supporting ADA building code, see page 47 for more details
- Passage and locking options
 - Thumb-turn deadbolt lock is received into a floor socket
 - Rim cylinder with SFIC format
 - SFIC core for field-keying to building requirements
 - Best E keyway
 - Random keying
 - Use SFIC for any custom keying requirements
 - Master keying, LFIC, and other RIM cylinders are available as a custom option

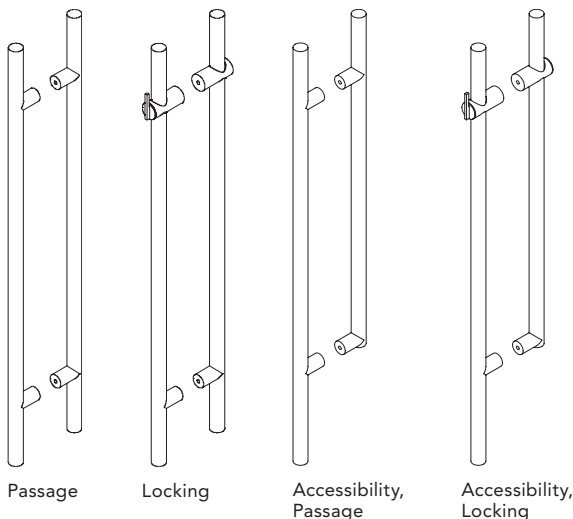

Passage

Locking

Accessibility,
Passage

Accessibility,
Locking

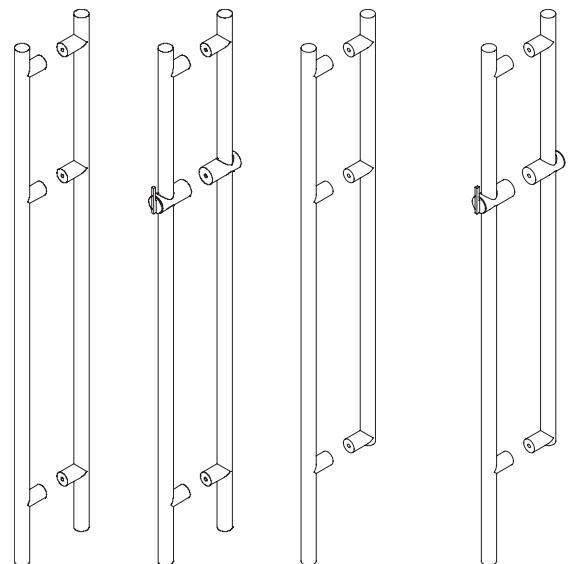

Passage

Locking

Accessibility,
Passage

Accessibility,
Locking

Accessibility Ladder Pulls



49" H Accessibility,
Passage

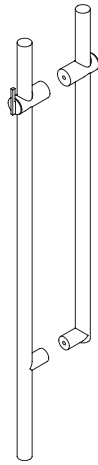

49" H Accessibility,
Locking

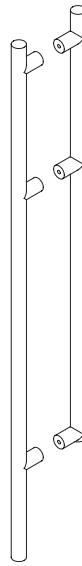

60" H Accessibility,
Passage



60" H Accessibility,
Locking

Accessibility ladder pulls are offered on doors as a solution where required for ADA.

- Accessibility ladder pulls feature an asymmetrical design where the bottom of the ladder pull aligns with the bottom of the door on one side of the door but does not extend down to the bottom of the door on the opposite side.
- The thin frame door leaf has also been designed with an offset glass feature, designed to create a smooth surface on one side of the door with an offset on the opposite side of the door.
 - In swing-door applications, the smooth side of the glass offset will always be on the push side of the door.
- Although this product has been designed with input from ADA, Allsteel is not certified or licensed to enforce building code and it is the responsibility of the specifiers, architect, and/or design firm to ultimately ensure that the way that the product is being used or specified will meet local and state building codes within that specific jurisdiction.

Cylindrical Lever

- Passage (non-locking) and locking with standard format interchangeable core (SFIC) lever options can be specified with Allsteel's cylindrical lever housing.
- Lever housing accommodates other manufacturers' cylinder-style locks as a custom option.

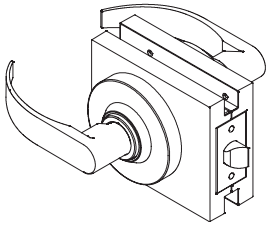

Passage

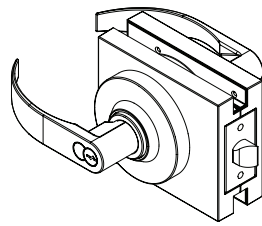

Locking with SFIC

Mortise Lever & Mortise Lever Housing

- Offered as either passage (non-locking), locking with standard format interchangeable core (SFIC), or locking with standard format interchangeable core, less core (SFIC-LC).
- Only offered on thin frame aluminum hinged doors, see Door Hardware Reference Guide (pages 38-40) for full hardware application guide.
- Must be specified with mortise lever housing (model AS-MHOUSING).

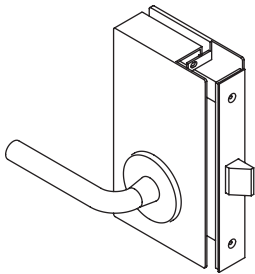

Passage, Straight Mortise Lever

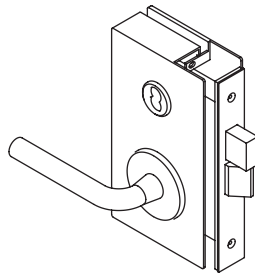

Locking, Straight Mortise Lever

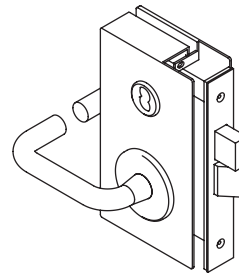

Locking, Return/Title 24 Mortise Lever

Magnetic Catch

- Painted to match trim finish
- For use with center swing pivot frameless doors when specified with a pull.

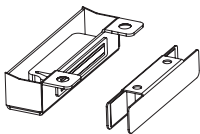

Magnetic Catch

Door Stops

Cylindrical Door Stop

- Floor-mounted.
- Height is 1½" (1.5").

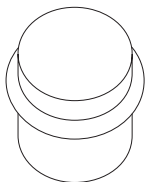

Dome Cylindrical Door Stop

- Floor-mounted.
- Height is 1⅛" (1.125") with optional spacer to increase height to 1½" (1.5").

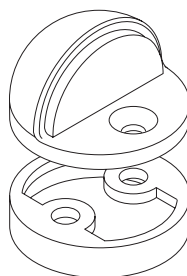

Electronic Locking

The optional electronic locking feature on Aspect thin framed doors offers keyless entry and remote access when integrated with building security systems and/or electronic card readers.

- For use with Aspect thin framed glass sliding doors & hinge doors only.
- Locking mechanism includes electronic flushbolt with integrated position sensor and a 14' wire to provide power-access to locking mechanism on door.
 - Hinge door model also includes concealed door loop to pass wire between door & door frame
- Electronic lock is offered as either Failsafe or Failsecure function
 - Failsecure Operation: In the case of a power outage, door will automatically lock. Recommended for high security applications only.
 - Note: There is no override feature provided with this lock, additional power supply recommended for this application.
 - Failsafe Operation: In the case of a power outage, door will automatically unlock. Recommended for life safety applications.
- In hinged, single-door applications, electronic lock will mount into the vertical strike side of the door and locks into the door jamb.
- In hinged, double-door applications, electronic lock will mount into header of the door and lock into the header of the door frame.
 - When specifying electronic locking on a sliding door, please note that the glass offset must be towards the door frame.
- It is recommended that a low-voltage security installer is responsible for wiring & integration of lock with building security system. Work with project manager to coordinate installation. Please note that this model includes the locking mechanism and other accessories outlined above only. Allsteel does not provide the building security system, card-readers, or exit devices and these items must be sourced separately.

Finish options:

Silver (satin stainless steel US32D)

Black (oxidized black + lacquer US19)

Manufactured by SDC

Sliding Doors

Aspect™ — Frameless Glass Sliding Door Leaf & Frame

ASPECT
TABLE OF CONTENTS

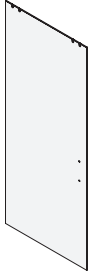

Frameless Glass Sliding, Single

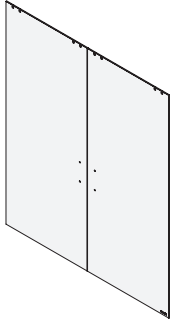

Frameless Glass Sliding, Double

ASPECT
FINISHES

ASPECT
PANELS & TRIM

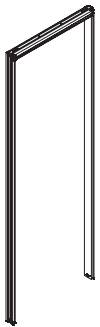

Sliding Door Frame, Single

ASPECT
DOORS

ASPECT
CONNECTORS

Base Model	Description	Specification
AS-FGSDLEAF	Frameless Glass Sliding Door Leaf	AS-FGSDLEAF

Configuration ID	Specification Description	
Product	Aspect	
Width	42" - Single Door 78" - Double Door	
Height	86"-120" in 1/4" increments	
Door Type	Sliding	
Door Style	Frameless Glass	
Door Module	Single Double	
Handle Type	Ladder Pull	
Ladder Pull Options	Height 12" Value 20" 49" Passage 49" Accessibility and/or Locking 60" Passage 60" Accessibility and/or Locking	Ladder Pull Placement Options Justified to Strike Only Justified to Strike Only Can be Justified to Bottom, Center, Strike, or Top Justified to Bottom Only Can be Justified to Bottom, Center, Strike, or Top Justified to Bottom Only
Glass Code	TA: 3/8" Tempered Clear TB: 3/8" Tempered Low Iron	

Option	Specification Description	Specification
Glass Selection	2-digit glass code	See above - Glass Finish options

Specification Example: AS-FGSDLEAF.#####.TA

Base Model	Description	Specification
AS-SDFRAME	Sliding Door Frame	AS-SDFRAME

Configuration ID	Specification Description	
Product	Aspect	
Width	42" - Single Door 78" - Double Door	
Height	86"-120" in 1/4" increments	
Door Type	Sliding	
Door Style	Frameless Glass Thin Aluminum Framed	
Door Module	Single Double	
Hand	<i>Field will populate if thin aluminum framed glass is specified</i> Left Right	
Lock Style	Passage or Floor-Locking Mortise (NOTE: Only active door will have mortise patch housing)	
Electronic Lock Style	Electronic Locking No Electronic Locking	
Frame Finish	Painted or Anodized Finishes	

Option	Specification Description	Specification
Paint Color Selection	3-digit painted or anodized finish	See Aspect Frame Finishes

Specification Example: AS-SDFRAME.#####.P8X

Sliding Doors

Aspect™ — Thin Aluminum Framed Sliding Door Leaf



Thin Aluminum Framed Sliding Door, Single

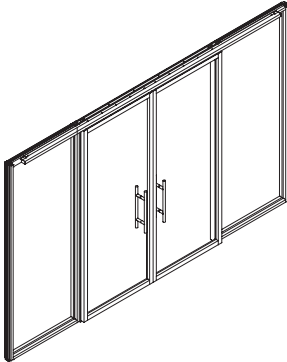

Thin Aluminum Framed Sliding Door, Double

Base Model	Description	Specification
AS-TALSDLEAF	Thin Aluminum Framed Glass Sliding Door Leaf	AS-TALSDLEAF
Configuration ID	Specification Description	
Product	Aspect	
Width	42" or 48" - Single Door 78" - Double Door	
Height	86" - 120" up to 42"W in ¼" increments 86" - 108¾" up to 48"W in ¼" increments	
Strike Style	<i>Field will populate if full strike is selected</i> Full Strike Full Strike Locking (NOTE: Must be selected for jamb locking)	
Door Type	Sliding	
Door Style	Thin Aluminum Framed	
Door Module	Single Double (NOTE: If locking, order QTY 1 active door and QTY 1 inactive door for double door application)	
Hand	Left Right	
Leaf Type	<i>Field will populate if double is selected</i> Active Inactive (When Locked)	
Glass Offset	Glass Offset Towards Door Frame Glass Offset Away from Door Frame	
Handle Type	Ladder Pull	
Ladder Pull Options	Height 12" Value 20" 49" Passage 49" Accessibility and/or Locking 60" Passage 60" Accessibility and/or Locking	Ladder Pull Placement Options Justified to Strike Only Justified to Strike Only Can be Justified to Bottom, Center, Strike, or Top Justified to Bottom Only Can be Justified to Bottom, Center, Strike, or Top Justified to Bottom Only
Lock Style	Passage or Floor-Locking Mortise (NOTE: Only active door will have mortise patch housing)	
Electronic Lock Style	Electronic Locking No Electronic Locking	
Glass Code	See below for glass finish options	
Aluminum Rail Finish	See Aspect Frame Finishes	
Option	Specification Description	Specification
Glass Selection	TA: ⅜" Tempered, Clear TB: ⅜" Tempered, Low Iron	
Paint Color Selection	3-digit painted or anodized finish	

Specification Example: AS-TALSDLEAF.####.TA.P8X

Sliding Doors



Sliding Door Track, Single

Base Model	Description	Specification
AS-SDTRACK	Sliding Door Track	AS-SDTRACK
Configuration ID	Specification Description	
Product	Aspect	
Width	42" - Single Door 78" - Double Door	
Height	86"-120" in ¼" increments	
Door Type	Sliding	
Door Style	Frameless Glass Thin Aluminum Framed	
Door Module	Single Double	
Closer	Will populate if Slow Close is selected: Sliding Slow Close	
Frame Finish	Painted or Anodized Finishes	
Option	Specification Description	Specification
Paint Color Selection	3-digit painted or anodized finish	See Aspect Frame Finishes

Specification Example: AS-SDTRACK.#####.P8X

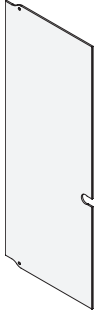

Frameless Glass Pivot, Single

Base Model	Description	Specification
AS-FGPDLEAF	Frameless Glass Pivot Door Leaf	AS-FGPDLEAF
Configuration ID	Specification Description	
Product	Aspect	
Width	39"	
Height	86"-120" in ¼" increments	
Strike Style	Will populate if specified with a ladder pull: Magnetic Catch	
Door Type	Pivot	
Door Style	Frameless Glass	
Handle Type	Ladder Pull Lever	
Ladder Pull Options	<i>Field will populate if Ladder Pull is selected</i> Height 12" 20" 49" Passage 49" ADA and/or Locking 60" Passage 60" ADA and/or Locking	
		Ladder Pull Placement Options Justified to Strike Only Justified to Strike Only Can be Justified to Bottom, Center, Strike, or Top Justified to Bottom Only Can be Justified to Bottom, Center, Strike, or Top Justified to Bottom Only
Glass Code	HA: ½" Tempered Clear HB: ½" Tempered Low Iron	

Option	Specification Description	Specification
Glass Selection	2-digit glass code	See above - Glass Finish options

Specification Example: AS-FGPDLEAF.#####.HA

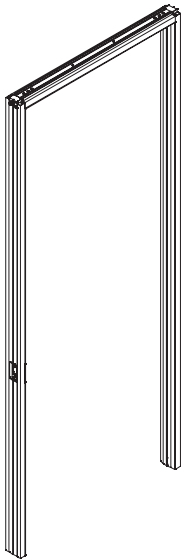

Pivot Door Frame

Base Model	Description	Specification
AS-PDFRAME	Pivot Door Frame	AS-PDFRAME
Configuration ID	Specification Description	
Product	Aspect	
Width	39"	
Height	86"-120" in ¼" increments	
Strike Style	Will populate if specified with a lever: Partial	
Door Type	Pivot	
Door Style	Frameless Glass Thin Aluminum Framed	
Door Module	Single Double	
Hand	<i>Field will populate if thin aluminum framed glass is specified</i> Left Right	
Lock Style	Mortise Lever Cylindrical Lever Passage or Floor-Locking	
Electronic Lock Style	<i>Field will populate if thin aluminum framed glass is specified</i> No Electronic Locking Electronic Locking	
Closure Style	<i>Field will populate if thin aluminum framed glass is specified</i> Lever Latch Roller Latch	
Glass Code	See below for glass finish options	
Frame Finish	Painted or Anodized Finishes	

Option	Specification Description	Specification
Paint Color Selection	3-digit painted or anodized finish	See Aspect Frame Finishes

Specification Example: AS-PDFRAME.#####.P8X

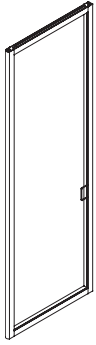

Thin Aluminum Framed Glass Pivot, Single

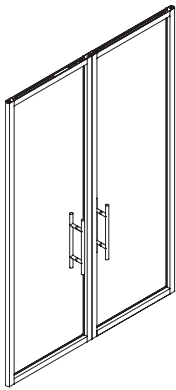

Thin Aluminum Framed Glass Pivot, Double

Base Model	Description	Specification
AS-TALPDLEAF	Thin Aluminum Framed Glass Pivot Door Leaf	AS-TALPDLEAF
Configuration ID	Specification Description	
Product	Aspect	
Width	39" - Single Door 75" - Double Door	
Height	86"-120" in ¼" increments	
Strike Style	Field will populate if Cylindrical Lever is selected Partial Strike Field will populate if Ladder Pull is selected None	
Door Type	Pivot	
Door Style	Thin Aluminum Framed	
Door Module	Single Double (NOTE: Order QTY 2 doors for double door application)	
Hand	Left Right	
Leaf Type	Field will populate if double is selected Active Inactive	
Lock Style	Passage Floor - Locking	
Closure Style	Field will populate if thin aluminum framed glass is specified Lever Latch Roller Latch	
Handle Type	Pull Lever	
Ladder Pull Options	Field will populate if Ladder Pull is selected Height 12" 20" 49" Passage 49" ADA and/or Locking 60" Passage 60" ADA and/or Locking	Ladder Pull Placement Options Justified to Strike Only Justified to Strike Only Can be Justified to Bottom, Center, Strike, or Top Justified to Bottom Only Can be Justified to Bottom, Center, Strike, or Top Justified to Bottom Only
Pull Style	Will populate if Ladder Pull is selected Roller Latch	
Glass Code	See below for glass finish options	
Aluminum Rail Finish	See Aspect Frame Finishes	

Option	Specification Description	Specification
Glass Selection	TA: ⅜" Tempered, Clear TB: ⅜" Tempered, Low Iron	
Paint Color Selection	3-digit painted or anodized finish	

Specification Example: AS-TALPDLEAF.####.TA.P8X

Pivot Doors

Aspect™ — Pivot Mount & Magnetic Catch

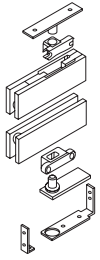

Pivot Door Mounting Hardware, Frameless Glass

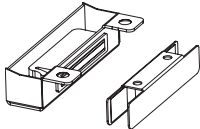

Magnetic Catch

Base Model	Description	Specification
AS-PIVOTMOUNT	Pivot Mount - Single Door	AS-PIVOTMOUNT

Option	Specification Description	Specification
Door Material	Frameless Glass	FG
	Aluminum-Framed/Wood	AL-WD
Finish Option	3-digit finish code	See Aspect hardware finishes

Specification Example: AS-PIVOTMOUNT.FG.SIL

Base Model	Description	Specification
AS-MAGCATCH	Magnetic Catch	AS-MAGCATCH

Option	Specification Description	Specification
Paint Color Selection	See Aspect painted metal finish options	3-digit finish code

Specification Example: AS-MAGCATCH.P8X

Hinged Doors

Aspect™ — Frameless Glass Hinged Door Leaf

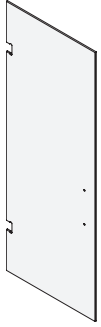

Frameless Glass Hinged, Single

Base Model	Description	Specification
AS-FGHDLEAF	Frameless Glass Hinged Door Leaf	AS-FGHDLEAF

Configuration ID	Specification Description
Product	Aspect

Width	39"
-------	-----

Height	86"-120" in ¼" increments
--------	---------------------------

Door Type	Hinged
-----------	--------

Door Style	Frameless Glass
------------	-----------------

Door Module	Single
-------------	--------

Handle Type	Ladder Pull
-------------	-------------

Ladder Pull Options	<i>Field will populate if Ladder Pull is selected</i>
---------------------	---

Height	Ladder Pull Placement Options
12"	Justified to Strike Only
20"	Justified to Strike Only
49" Passage	Can be Justified to Bottom, Center, Strike, or Top
49" ADA and/or Locking	Justified to Bottom Only
60" Passage	Can be Justified to Bottom, Center, Strike, or Top
60" ADA and/or Locking	Justified to Bottom Only

Glass Selection	HA: ½" Tempered Clear HB: ½" Tempered Low Iron
-----------------	---

Option	Specification Description	Specification
Glass Code	2-digit glass code	See above - Glass Finish options

Specification Example: AS-FGHDLEAF.####.QA

Hinged Doors

Aspect™ — Solid Hinged Door Leaf

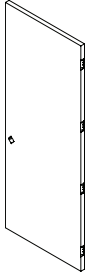

Solid Hinged, Single

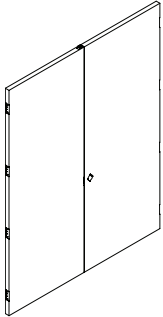

Solid Hinged, Double

Base Model	Description	Specification
AS-SLDHLEAF	Solid Hinged Door Leaf	AS-SLDHLEAF
Configuration ID	Specification Description	
Product	Aspect	
Width	39" - Single Door 75" - Double Door	
Height	86"-120" in ¼" increments	
Door Type	Hinged	
Door Style	Wood	
Door Module	Single Double	
Hand	Left Right	
Leaf Type	Will populate if double door is selected Active Inactive	
Handle Type	Ladder Pull Cylindrical Lever	
Ladder Pull Options	<i>Field will populate if Ladder Pull is selected</i> Height 12" 20" 49" Passage 49" ADA and/or Locking 60" Passage 60" ADA and/or Locking	Ladder Pull Placement Options Justified to Strike Only Justified to Strike Only Can be Justified to Bottom, Center, Strike, or Top Justified to Bottom Only Can be Justified to Bottom, Center, Strike, or Top Justified to Bottom Only
Closure Style	<i>Will populate if Ladder Pull is selected</i> Roller Latch No Latch (Self-Closing Hinges) <i>Will populate if a lever is selected</i> Lever Latch	
Floor Treatment	Will populate if drop seal is selected Drop Seal	
FSC	Not FSC-Certified FSC-Certified	X FSC
Finish	Veneer, Laminate or Painted Wood Finish	
Transom	<i>Field will populate if 85"H single door is selected</i> Yes No	
Transom	No	
Laminate Finish	Designer White 15051	
Option	Specification Description	Specification
FSC Option	Not FSC-Certified FSC Certified	X FSC
Material Grade and Color Option	Veneer - See Aspect Veneer Finishes Laminate - See Aspect Laminate Finishes Painted Wood - See Aspect Painted Wood Finishes	See Aspect Materials & Finishes

Specification Example: AS-SLDHLEAF.#####.FSC.LWC

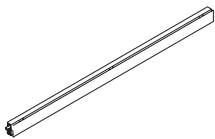

Base Model	Description	Specification
AS-SLDBTMSEAL	Aluminum/Solid Hinged Door Bottom Seal	AS-SLDBTMSEAL

Specification Example: AS-SLDBTMSEAL

Hinged Doors

Aspect — Thin Aluminum Framed Hinged Door Leaf

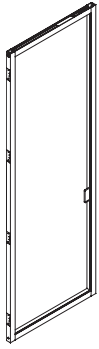

Thin Aluminum Framed Glass Hinged, Single

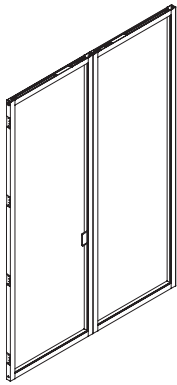

Thin Aluminum Framed Glass Hinged, Double

Base Model	Description	Specification
AS-TALHDLEAF	Thin Aluminum Framed Glass Hinged Door Leaf	AS-TALHDLEAF
Configuration ID	Specification Description	
Product	Beyond	
Width	39" - Single Door 75" - Double Door	
Height	86"-120" up to 42"W in ¼" increments	
Strike Style	Full Strike	
Door Type	Hinged	
Door Style	Thin Aluminum Frame	
Door Module	Single Double (NOTE: If adjacent door-locking, order QTY 1 active door and QTY 1 inactive door for double door application. If passage or floor-locking, order QTY 2 active door.)	
Hand	Left Right	
Leaf Type	<i>Field will populate if double is selected</i> Active Inactive	
Handle Type	Ladder Pull Cylindrical Lever Mortise Lever	
Ladder Pull Options	<i>Field will populate if Ladder Pull is selected</i> Height 12" 20" 49" Passage 49" ADA and/or Locking 60" Passage 60" ADA and/or Locking	Ladder Pull Placement Options Justified to Strike Only Justified to Strike Only Can be Justified to Bottom, Center, Strike, or Top Justified to Bottom Only Can be Justified to Bottom, Center, Strike, or Top Justified to Bottom Only
Closure Style	<i>Will populate if Ladder Pull is selected</i> Roller Latch No Latch (Self-Closing Hinges) <i>Will populate if a lever is selected</i> Lever Latch	
Floor Treatment	Drop Seal	
Lock Style	<i>Field will populate if Ladder Pull is selected</i> Passage or Floor-Locking Mortise	
Electronic Lock Style	Electronic Locking No Electronic Locking	
Glass Code	See below for glass finish options	
Aluminum Rail Finish	See Aspect Frame Finishes	
Option	Specification Description	Specification
Glass Selection	TA: ¾" Tempered, Clear TB: ¾" Tempered, Low Iron	
Paint Color Selection	3-digit painted or anodized finish	

Specification Example: AS-TALHDLEAF.####.TA.P8X

Hinged Doors

Aspect — Hinged Door Frame & Mount

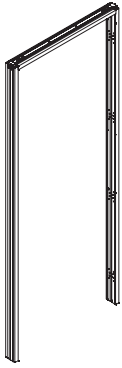

Hinged Door Frame, Single

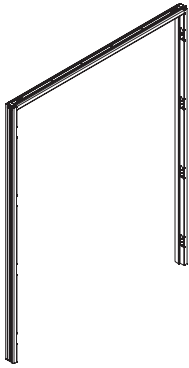

Hinged Door Frame, Double

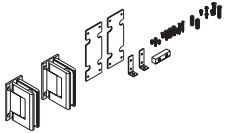

Hinged Door Mounting Hardware, Frameless Glass



Hinged Door Mounting Hardware, Single Aluminum Framed/Wood

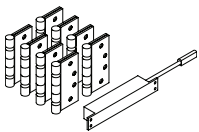

Hinged Door Mounting Hardware, Double Aluminum Framed/Wood

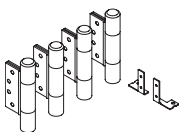

Self-Closing Hinges

Base Model	Description	Specification
AS-HDFRAME	Hinged Door Frame	AS-HDFRAME
Configuration ID	Specification Description	
Product	Aspect	
Width	39" - Single Door 75" - Double Door	
Height	86"-120" in ¼" increments	
Strike Style	Will populate if specified with a wood or aluminum framed door Full	
Door Type	Hinged	
Door Style	Frameless Glass Wood or Aluminum	
Door Module	Single Double	
Hand	Will populate if specified with wood or aluminum framed door Left Right	
Lock Style	Cylindrical Lever Mortise Mortise Lever Passage or Floor-Locking	
Electronic Lock Style	Electronic Locking No Electronic Locking	
Frame Finish	Painted or Anodized Finishes	
Option	Specification Description	Specification
Paint Color Selection	3-digit painted or anodized finish	See Aspect Frame Finishes

Specification Example: AS-HDFRAME.#####.P8X

Base Model	Description	Specification
AS-HINGEDMOUNT	Hinged Door Mounting Hardware	AS-HINGEDMOUNT
Option	Specification Description	Specification
Hinge Configuration		
Door Module	Single Double	S D
Type/Functionality sub-option	Frameless Glass Aluminum Framed/Wood	FGCLSR AL-WDNCSR
Trim Color	3-digit code	See Aspect hardware finishes

Specification Example: AS-HINGEDMOUNT.SAL-WDNCSR.SIL

Base Model	Description	Specification
AS-HINGEDMOUNTCLSR	Self-Closing Hinges	AS-HINGEDMOUNTCLSR
Option	Specification Description	Specification
Hinge Configuration	Single Double	S D
Type/Functionality	Aluminum Framed/Wood	AL-WD
Trim Color	3-digit finish code	See Aspect hardware finishes

Specification Example: AS-HINGEDMOUNTCLSR.S.SIL



12"

Base Model	Description	Specification
AS-PULL12	12" Ladder Pull	AS-PULL12

Option	Specification Description	Specification
Door Material	Frameless Glass Aluminum-Framed/Wood	FG AL-WD
Trim Color	3-digit code	See Aspect hardware finishes

Specification Example: AS-PULL12.FG.SIL



12"

Base Model	Description	Specification
AS-PULL12V	12" Value Ladder Pull	AS-PULL12V

Option	Specification Description	Specification
Door Material	Frameless Glass Aluminum-Framed/Wood	FG AL-WD
Trim Color	3-digit code	See Aspect hardware finishes

Specification Example: AS-PULL12V.FG.SIL



20"

Base Model	Description	Specification
AS-PULL20	20" Ladder Pull	AS-PULL20

Option	Specification Description	Specification
Trim Color	3-digit code	See Aspect hardware finishes

Specification Example: AS-PULL20.SIL

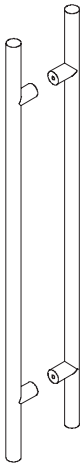

49"

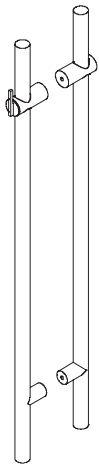

Base Model	Description	Specification
AS-PULL49	49" Ladder Pull	AS-PULL49

Option	Specification Description	Specification
Locking Option	Passage Locking with SFIC	P SFIC
Trim Color	3-digit code	See Aspect hardware finishes

Specification Example: AS-PULL49.P.SIL

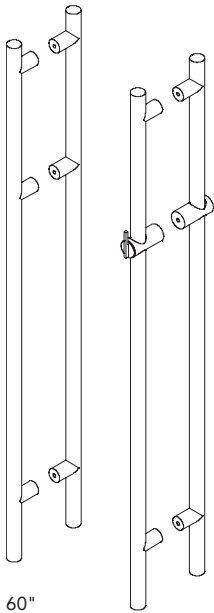

60"

Base Model	Description	Specification
AS-PULL60	60" Ladder Pull	AS-PULL60

Option	Specification Description	Specification
Locking Option	Passage	P
	Locking with SFIC	SFIC
Trim Color	3-digit code	See Aspect hardware finishes

Specification Example: AS-PULL60.P.SIL

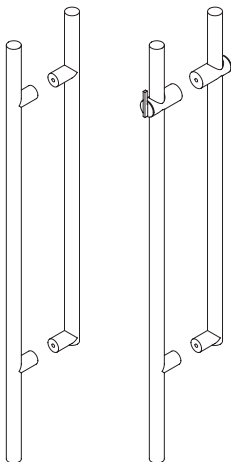

49"H ADA
Passage

49"H ADA
Locking
with SFIC

Base Model	Description	Specification
AS-PULL49ADA	49" Ladder Pull, ADA	AS-PULL49ADA

Option	Specification Description	Specification
Locking Option	Passage	P
	Locking with SFIC	SFIC
	SFIC Locking - Less Core	SFIC-LC
Trim Color	3-digit finish code	See Aspect hardware finishes

Specification Example: AS-PULL49ADA.P.SIL

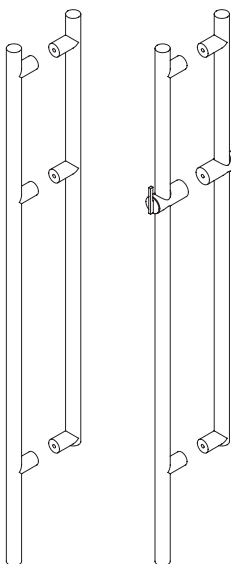

60"H ADA
Passage

60"H ADA
Locking
with SFIC

Base Model	Description	Specification
AS-PULL60ADA	60" Ladder Pull, ADA	AS-PULL60ADA

Option	Specification Description	Specification
Locking Option	Passage	P
	Locking with SFIC	SFIC
	SFIC Locking - Less Core	SFIC-LC
Trim Color	3-digit finish code	See Aspect hardware finishes

Specification Example: AS-PULL60ADA.P.SIL

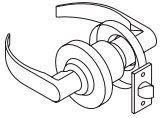

Passage, Aluminum Framed/Wood

Base Model	Description	Specification
AS-LEVER	Cylindrical Lockset	AS-LEVER
Option	Specification Description	Specification
Locking Option	Passage Locking with SFIC	P SFIC
Trim Color	3-digit code	See Aspect hardware finishes
Door Material	Frameless Glass Aluminum-Framed/Wood	FG AL-WD

Specification Example: AS-LEVER.P.SIL.FG

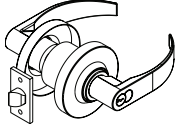

Locking with SFIC, Aluminum Framed/Wood

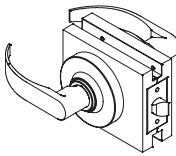

Passage, Frameless Glass

Base Model	Description	Specification
AS-HOUSING	Cylindrical Lever Housing	AS-HOUSING
Option	Specification Description	Specification
Trim Color	3-digit finish code	See Aspect frame finishes

Specification Example: AS-HOUSING.P8X

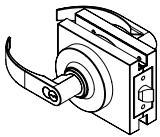

Locking with SFIC, Frameless Glass

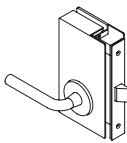

Passage, Straight Mortise Lever

Base Model	Description	Specification
AS-MLEVER	Mortise Lever	AS-MLEVER
Option	Specification Description	Specification
Locking Option	Passage Locking with SFIC Locking with SFIC, Less Core	P SFIC SFIC-LC
Door Style	Thin Aluminum Framed	TAF
Lever Style	Straight Lever Return Lever, Title 24 Compliant	SL RL
Trim Color	3-digit finish code	See Aspect hardware finishes

Specification Example: AS-MLEVER.P.TAF.SL.SIL

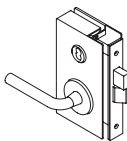

Locking, Straight Mortise Lever

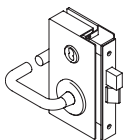

Locking, Return/Title 24 Mortise Lever

Base Model	Description	Specification
AS-MHOUSING	Mortise Lever Housing	AS-MHOUSING
Option	Specification Description	Specification
Locking Option	Passage Locking with SFIC	P SFIC
Hand	Right Left	R L
Trim Color	3-digit finish code	See Aspect frame finishes

Specification Example: AS-MHOUSING.P.R.P8X



Dome

Base Model	Description	Specification
AS-DOMESTOP	Dome Door Stop	AS-DOMESTOP
Option	Specification Description	Specification
Trim Color	3-digit code	See Aspect hardware finishes

Specification Example: AS-DOMESTOP.SIL



Cylindrical

Base Model	Description	Specification
AS-CYLSTOP	Cylindrical Door Stop	AS-CYLSTOP
Option	Specification Description	Specification
Trim Color	3-digit code	See Aspect hardware finishes

Specification Example: AS-CYLSTOP.SIL

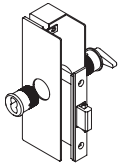

Base Model	Description	Specification
AS-SWINGLOCK	Swing Door Lock	AS-SWINGLOCK
Option	Specification Description	Specification
Locking Option	SFIC Locking SFIC Locking - Less Core	SFIC SFIC-LC
Door Material	Thin Aluminum Framed	TAF
Trim Color	3-digit finish code	See Aspect hardware finishes
Trim Color	3-digit finish code	See Aspect Frame Finishes

Specification Example: AS-SWINGLOCK.SFIC.TAF.SIL.PRO

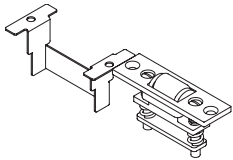

Base Model	Description	Specification
AS-ROLLERLATCH	Roller Latch	AS-ROLLERLATCH
Option	Specification Description	Specification
Module Option	Single Double	S D

Specification Example: AS-ROLLERLATCH.S

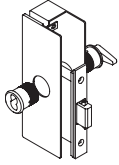

Thin Framed Sliding Door Lock

Base Model	Description	Specification
AS-SLIDINGLOCK	Sliding Door Lock	AS-SLIDINGLOCK
Option	Specification Description	Specification
Locking Option	SFIC Locking	SFIC
	SFIC Locking - Less Core	SFIC-LC
Door Material	Thin Aluminum Framed	TAF
Trim Color	3-digit finish code	See Aspect hardware finishes
Trim Color	3-digit finish code	See Aspect frame finishes

Specification Example: AS-SLIDINGLOCK.SFIC.TAF.SIL.PRO

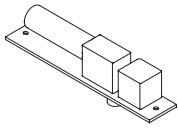

Sliding Door Electronic Lock

Base Model	Description	Specification
AS-SLIDINGELECLOCK	Sliding Door Electronic Lock	AS-SLIDINGELECLOCK
Option	Specification Description	Specification
Type	Single	S
	Double Active	D
Lock	Electronic Lock - Failsafe	SF
	Electronic Lock - Failsecure	SC
Trim Color	3-digit finish code	See Aspect hardware finishes

Specification Example: AS-SLIDINGELECLOCK.S.SF.SIL

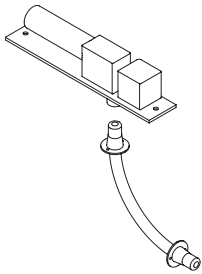

Hinged Door Electronic Lock

Base Model	Description	Specification
AS-HINGEDELECLOCK	Hinged Door Electronic Lock	AS-HINGEDELECLOCK
Option	Specification Description	Specification
Type	Single	S
	Double Active	DAA
	Double Active / Inactive	DAI
Lock	Electronic Lock - Failsafe	SF
	Electronic Lock - Failsecure	SC
Option	Specification Description	Specification
Trim Color	3-digit finish code	See Aspect hardware finishes

Specification Example: AS-HINGEDELECLOCK.S.SF.SIL

Doors are the first component installed when working with Aspect.

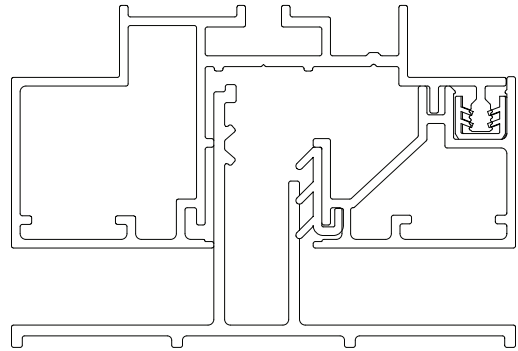

Door Frame to Drywall Wall Channel

- Aspect panels can be specified with a variety of door and hardware options.
- When connecting a door frame to drywall, utilize the door frame to drywall wall channel (specified as base model AS-DWCHANNEL).
- Aspect panels can be specified with a variety of door and hardware options.
 - Doors can reach a maximum height of 120" with a minimum height of 84".
 - All specification for door sizes is nominal. This differs from the glass panels which are specified in actual sizes.
 - Door height is specified in quarter inch ($\frac{1}{4}$ ") increments.
 - Doors specified at nominal height have a half inch ($\frac{1}{2}$ ") planned clearance between the bottom of the door and the floor.
 - Door clearances should be confirmed on the job site with field measurements for both the open and closed positions of the door.
 - All doors have a set width per module (nominal size of the door with frame).
- Utilize door frame to drywall wall channel (specified as base model AS-DWCHANNEL) when connecting a door directly to drywall.
- A door frame corner block is QTY (2) corner blocks are automatically included with each door frame



Wall Channel

- Wall channels are used when Aspect glass intersects with drywall or the building interior. Wall channel is comprised of the same 2-piece universal trim as the top and bottom trim; however, the wall channel contains a notch at the top. This notch is necessary for the trim component to clear the glass gasket during installation.
- Dimensions
 - 1¹/₁₆" tall
 - 3¹/₂" wide
 - 1/2" reveal
- Wall channels also come with QTY (2) corner blocks
 - Corner blocks help with the alignment of the vertical and horizontal elements and create a continuous reveal.
 - Corner blocks are automatically included and do not need to be specified.
- Wall channels have +/- 1/4" of adjustment.
- Wall channels are used to connect glass to drywall, glass to door frame, and when glass intersects a drywall end cap.
 - Specify QTY (1) from glass to drywall.
 - Specify QTY (1) from glass to door frame.
 - Specify QTY (1) from glass to end cap.

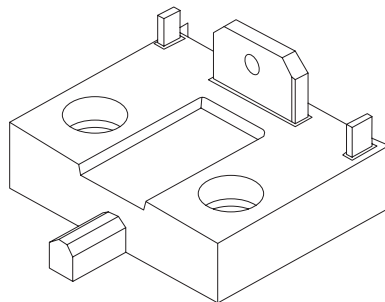

Wall Channel Corner Block

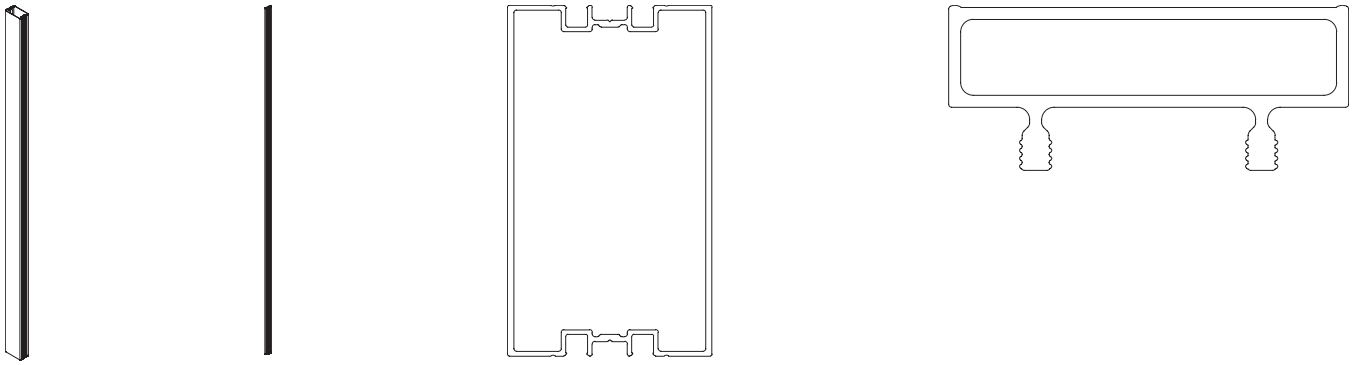

Drywall End Cap

Drywall end caps are used to create a clean, continuous look across a wall run. Three-way drywall end caps are used at a three-way connection where drywall connects perpendicularly to Aspect (typically as a demising wall). The end of the Aspect wall terminates in a drywall end cap post that extends to cover the width of the drywall. Drywall endcap adapters are used to connect an Aspect door frame into the drywall end cap.

- Drywall end caps should be planned so the end of the drywall end cap post aligns with the face of the perpendicular drywall.
 - The 6" wide three-way post is engineered to accommodate drywall widths up to 5½". They should be planned so the centerline of the post aligns with the centerline of the perpendicular drywall. Contact Architectural Products Engineering prior to shop drawing completion if specifying a door adjacent to a drywall end cap with a ladder pull or non-standard lever set for the door hardware to ensure the door will open a full 90 degrees.
- One full height length strip of foam tape is installed to provide an acoustic seal at the demising drywall condition. Allsteel will also supply a piece of foam for the top gap between the ceiling channel and the drywall.
- Dimensions
 - Actual and planning dimensions of a three-way drywall end cap are 6" wide.

- Service Kit:
 - Specified as base model AS-SERVICEKIT
 - Need 1 kit per 500 LF
 - Finish type must be specified on Service Kit
 - Contains sliding door mounting hardware, various screws, and vhb tape to assist with installation.
- Touch Up Paint Kit, Brush:
 - Specified as base model APTK
 - Need 1 kit per 1000 LF
 - Finish specified to match trim finish
 - Bottle of touch up paint with brush - 0.5 oz.
- Touch Up Paint Kit, Spray:
 - Specified as base model ARSLCC
 - Need 1 kit per 1000 LF
 - Finish specified to match trim finish
 - Spray can of touch up paint - 12 oz.

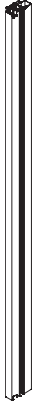

Base Model	Description	Specification
AS-SGWCHANNEL	Vertical Frameless Glass Wall Channel	AS-SGWCHANNEL
Configuration ID	Specification Description	
Product	Aspect	
Dimension	120"	
Trim Type	Wall Channel	
Trim Use	Universal	
Finish Color	Painted or Anodized Finishes	
Option	Specification Description	Specification
Paint Color Selection	3-digit painted or anodized finish	See Aspect Frame Finishes

Specification Example: AS-SGWCHANNEL.#####.P8X



Base Model	Description	Specification
AS-DWCHANNEL	Wall Channel - Door Frame to Drywall	AS-DWCHANNEL
Configuration ID	Specification Description	
Product	Aspect	
Dimension	120"	
Trim Type	Wall Channel	
Trim Use	Adjacent Door	
Finish Color	Painted or Anodized Finishes	
Option	Specification Description	Specification
Paint Color Selection	3-digit painted or anodized finish	See Aspect Frame Finishes

Specification Example: AS-DWCHANNEL.#####.P8X

Base Model	Description	Specification
AS-SERVICEKIT	Service Kit	AS-SERVICEKIT
Option	Specification Description	Specification
Paint Color Selection	3-digit painted or anodized finish	See Aspect Frame Finishes

Specification Example: AS-SERVICEKIT.P8X

Base Model	Description	Specification
APTK	Touch Up Paint Brush Qty 1	APTK
Option	Specification Description	Specification
Trim Color	3-digit finish code	See Aspect Frame Finishes

Specification Example: APTK.P8X

Base Model	Description	Specification
ARSLCC	Spray Paint	ARSLCC
Option	Specification Description	Specification
Trim Color	3-digit finish code	See Aspect Frame Finishes

Specification Example: ARSLCC.P8X



Base Model	Description	Specification
AS-ENDCAP	Drywall Endcap	AS-ENDCAP
Configuration ID	Specification Description	
Product	Aspect	
Dimension	120"	
Trim Type	Drywall End Cap	
Trim Use	Universal	
Finish Color	Painted or Anodized Finishes	
Option	Specification Description	Specification
Paint Color Selection	3-digit painted or anodized finish	See Aspect Frame Finishes

Specification Example: AS-ENDCAP.#####.P8X



Base Model	Description	Specification
AS-DECAPADAPTER	Door to Drywall Endcap Adapter	AS-DECAPADAPTER
Configuration ID	Specification Description	
Product	Aspect	
Dimension	120"	
Trim Type	Drywall End Cap	
Trim Use	Adjacent Door	
Finish Color	Painted or Anodized Finishes	
Option	Specification Description	Specification
Paint Color Selection	3-digit painted or anodized finish	See Aspect Frame Finishes

Specification Example: AS-DECAPADAPTER.#####.P8X

Table of Contents.....	71	Beyond Panel & Trim Overview.....	76-163
Beyond Finishes.....	72	Working with Seismic.....	76-79
Beyond Fabrics.....	73	Working with Freestanding.....	80-86
Beyond Partnership Program Upholstery.....	74	Working with Freestanding: SDC A-B.....	87-96
Beyond Frame & Polymer Finish Matrix.....	75	Working with Freestanding & Wood Slats: SDC A-B.....	97-101
		Working with Freestanding: SDC C-F.....	102-108
		Working with Freestanding & Wood Slats: SDC C-F.....	109-111
		Working with Beyond Supported Suspended Ceiling.....	112-115
		Working with Ceiling Attachment.....	116-118
		Working with Base Channel & Leveling.....	119-121
		Working with Acoustic Performance.....	122-123
		Working with Frameless Panels & Trim.....	124-129
		Working with Framed / Solid Panels & Trim.....	130-155
		Working with Technology & Furniture Integration.....	156-163
		Beyond Panel & Trim Specifications.....	164-190
		Seismic Anchors.....	164
		Freestanding & Suspended Ceiling.....	165-166
		Ceiling Channel, Splice Kits, Clips, Spacer.....	167-168
		Frameless Glass, Trim, Keys, Vertical Fillers.....	169-172
		Framed Glass & Wood Slat Infill Panels.....	173-176
		Solid Panels, Frames, Tiles.....	177-186
		Framed / Solid Base Trim & Zippers.....	187-188
		Technology & Furniture Integration.....	189-190
		Beyond Door & Hardware Overview.....	191-209
		Door and Hardware Matrix.....	191-193
		Working with Doors.....	194-204
		Working with Hardware.....	205-209
		Beyond Door & Hardware Specifications.....	210-233
		Freeway & Support Bracket.....	210
		Sliding Doors, Frames, Mounting Hardware.....	211-217
		Pivot Doors, Frames, Mounting Hardware.....	218-222
		Hinged Doors, Frames, Mounting Hardware.....	223-228
		Door Hardware.....	229-233
		Beyond Connector Overview.....	234-252
		Working with Frameless Connectors.....	234-237
		Working with Connectors.....	238-251
		Working with Kits.....	252
		Beyond Connector Specifications.....	253-265
		Frameless Wall Channel, Adapter, Finished End, U-Channel.....	253-255
		Wall Channel Door Adjacent, Small, Large.....	256-257
		Posts, Zipper-Based Connector, Drywall End Cap.....	258-263
		Finished End & Solid U-Channel.....	264
		Installation, Hard Surface, and Touch Up Paint Kits.....	265
		Beyond Electrical & Data Overview.....	266-281
		Working with Frameless Electrical & Data.....	266-270
		Working with Framed and Solid Electrical & Data.....	271-281
		Beyond Electrical & Data Specifications.....	282-286
		Frameless Electrical & Data.....	282-283
		Framed and Solid Electrical & Data.....	284-286
		Beyond Frameless Privacy Tile System.....	287-300
		Beyond Viz.....	301-311

GLASS TYPES

GRADE 1

1/2" Tempered, Clear.....	HA
1/4" Tempered, Clear.....	QA
3/8" Tempered, Clear.....	TA
3/16" Back-Painted, Low Iron, Markerboard, White.....	OA

GRADE 2

1/2" Laminated, Clear.....	HC
1/4" Laminated, Clear.....	QC
3/8" Laminated, Clear.....	TC

GRADE 3

1/2" Laminated, High Performance, Clear.....	HG
1/4" Laminated, High Performance, Clear.....	QG
3/8" Laminated, High Performance, Clear.....	TG

GRADE 4

1/2" Tempered, Low Iron.....	HB
1/4" Tempered, Low Iron.....	QB
1/4" Laminated, Clear, Translucent White.....	QE
3/8" Tempered, Low Iron.....	TB
3/8" Laminated, Low Iron.....	TD
3/8" Laminated, Clear, Translucent White.....	TE
3/16" Back-Painted, Low Iron, Markerboard, Magnetic, White.....	OB
5/16" Laminated, Low Iron, Markerboard, Magnetic.....	QW

GRADE 5

1/2" Laminated, Low Iron.....	HD
1/4" Laminated, Low Iron.....	QD

GRADE 6

1/2" Laminated, High Performance, Low Iron.....	HH
1/4" Laminated, Low Iron, Markerboard.....	QF
1/4" Laminated, High Performance, Low Iron.....	QH
1/4" Laminated, Clear, Markerboard.....	QL
1/4" Laminated, Clear, Markerboard, Black.....	QM
3/8" Laminated, Clear, Markerboard.....	TL

GRADE 7

3/8" Laminated, Low Iron, Markerboard.....	TF
3/8" Laminated, High Performance, Low Iron.....	TH
3/8" Laminated, Low Iron, Turquoise.....	TN
3/8" Laminated, Low Iron, Cherry.....	TP
3/8" Laminated, Low Iron, Lawn.....	TQ
3/8" Laminated, Low Iron, Jet.....	TR
3/8" Laminated, Low Iron, Mandarin.....	TS
3/16" Back Painted Low Iron, Cherry.....	JC
3/16" Back Painted Low Iron, Lawn.....	JL
3/16" Back Painted Low Iron, Mandarin.....	JM
3/16" Back Painted Low Iron, Turquoise.....	JT

BEYOND PAINTS

PAINT COLORS GRADE 1

Frames.....	P71
Black.....	P7D
Brownstone*.....	P7C
Bungalow*.....	P7Q
Cinder.....	P096
Cove.....	PJW
Designer White*.....	P094
Dune.....	P02
Flint*.....	P28
Fossil*.....	P097
Harbor.....	P7B
Loft*.....	P4J
Muslin*.....	P93
Parchment*.....	P8R
Pebble.....	P8D
Pewter.....	P095
Sage.....	P8C
Salt.....	P7J
Textured Brownstone**.....	XCBK
Textured Charblack**.....	PK7
Textured Designer White**.....	P7A
Textured Flint**.....	P7L
Textured Loft**.....	P7M
Textured Muslin**.....	P8Y
Textured Pebble**.....	P8Z
Textured Salt**.....	P8V
Textured Titanium.....	P8T
Titanium.....	

*Available on Solid Wood Door

**Available on Surface Tiles

BEYOND PAINTS – continued

PAINT COLORS GRADE 2

Champagne Metallic.....	PR5
Gunmetal Metallic.....	PR3
Matte Gold.....	P8G
Night Bronze.....	P8B
Pyrite.....	PJE
Silver.....	PR6
Solar Black.....	P8X

VENEER FINISHES

STRATAWOOD VENEERS - GRADE 2

All Tiles, Solid Doors

Beigewood.....	SE878
Belair.....	SE934
Burnished Cherry.....	SC777
Clear Cherry.....	SC700
Clear Maple.....	SE800
Clear Rift Oak.....	SF300
Clear Silver Oak.....	SB100
Dark Rift Oak.....	SF331
Field Elm.....	SE599
Florence Walnut.....	ST579
Harvest Maple.....	SE856
Light Cherry.....	SC701
Light Walnut.....	ST601
Lowell Ash Cherry.....	SC394
Phantom Ecru.....	SE912
Pinnacle Walnut.....	ST679
Portico Teak.....	SB150
Shaker Cherry.....	SC774
Skyline Walnut.....	ST625
Sumatra Walnut.....	ST693

NATURAL VENEERS - GRADE 2

Monolithic and Base Tiles Only, Solid Doors

Burnished Cherry.....	NC777
Cinnamon/Biltmore Cherry.....	NC260
Clear Maple.....	NE800
Ebony Walnut.....	NT509
Florence Walnut.....	NT579
Harvest Maple.....	NE856
Light Cherry.....	NC701
Light Walnut.....	NT601
Lowell Ash.....	NC394
Medium Red Cherry.....	NC512
Nutmeg Walnut.....	NT629
Pinnacle Walnut.....	NT679
Shaker Cherry.....	NC774
Skyline Walnut.....	NT625
Sumatra Walnut.....	NT693

NATURAL VENEERS - GRADE 3

Dark Rift Cut Oak.....	RF331
Fawn Cypress Rift Cut Oak.....	RF108
Light Rift Cut Oak.....	RF301
Natural Recon.....	RF896
Phantom Ecru Rift Cut Oak.....	RF912

LAMINATE FINISHES

SOLID LAMINATES - GRADE 1

All Tiles, Solid Doors

Black.....	P
Brownstone.....	LM13
Bungalow.....	LM12
Designer White.....	LDW1
Flint.....	LM16
Fossil Shale.....	LEH1
Loft.....	LM11
Muslin.....	LM15
Titanium.....	LT11

WOODGRAIN LAMINATES - GRADE 1

Monolithic and Base Tiles Only, Solid Doors

Belair.....	LWBA
Bourbon Cherry.....	H
Field Elm.....	LWFE
Florence Walnut.....	LFW1
Kingswood Walnut.....	LK11
NeoWalnut.....	LNU1
Pinnacle.....	PINC
Shaker Cherry.....	LW7C

LAMINATE FINISHES – continued

WOODGRAIN LAMINATES - GRADE 2

Monolithic and Base Tiles Only, Solid Doors

Beigewood.....	LWBE
Fawn Cypress.....	LFC1
Lowell Ash.....	LLA1
Mangalore Mango.....	LMM1
Natural Recon.....	LNR1
Phantom Charcoal.....	LPC1
Phantom Ecru.....	LPE1
Portico Teak.....	LPT1
Skyline Walnut.....	LSW1
Veranda Teak.....	LVT1

WOODGRAIN LAMINATES - GRADE 3

Monolithic and Base Tiles Only, Solid Doors

Natural Walnut.....	LWNW
---------------------	------

POLYMERS

BEYOND ZIPPERS

Designer White.....	DW
Grey.....	EC
Warm Tone.....	EF
Brownstone.....	BW
Black-Kloeber (20 gloss).....	E4

ELECTRICAL — FRAMED AND

SOLID PANELS

Black-Kloeber (20 gloss).....	E4
Brownstone.....	EY
Designer White.....	DW
Flint.....	E9
Loft.....	EV
Muslin.....	EU
Silver.....	ES

ELECTRICAL — FRAMELESS PANELS

Silver.....	ES
Black-Kloeber (20 gloss).....	E4

VERTICAL FILLERS — FRAMELESS

PANELS

Clear Polycarbonate.....	CPC
Satin Anodized Aluminum.....	SAL

EXPOSED DOOR HARDWARE

Silver.....	SIL
Black.....	BLK

WOOD SLAT FINISHES - GRADE 1

Clear Ash.....	AH400
Black Opaque Ash.....	AH402
Amber Ash.....	AH901
Smoke Opaque Ash.....	AH310
Grey Opaque Ash.....	AH403
Warm White Opaque Ash.....	AH404
Mist Opaque Ash.....	AH405
Denim Opaque Ash.....	AH406
Pewter Opaque Ash.....	AH407
Peppercorn Opaque Ash.....	AH408
Designer White Opaque Ash.....	AH902
Warm Brick Ash.....	AH911
Nutmeg Ash.....	AH929
Bark Ash.....	AH937
Dark Roast Ash.....	AH984
Sumatra Ash.....	AH993

WOOD SLAT FINISHES - GRADE 2

Smoke Opaque Walnut.....	NT310
Clear Walnut.....	NT400
Black Opaque Walnut.....	NT402
Grey Opaque Walnut.....	NT403
Warm White Opaque Walnut.....	NT404
Mist Opaque Walnut.....	NT405
Denim Opaque Walnut.....	NT406
Pewter Opaque Walnut.....	NT407
Peppercorn Opaque Walnut.....	NT408
Designer White Opaque Walnut.....	NT902
Warm Brick Walnut.....	NT911
Nutmeg Walnut.....	NT929
Bark Walnut.....	NT937
Dark Roast Walnut.....	NT984
Sumatra Walnut.....	NT993

For use with Solid Wall Tackable Fabric Tiles and Privacy Tile Tackable Fabric Tiles

GRADE A

APPOINT PANEL

Artichoke.....	APN911
Blackberry.....	APN932
Bronze.....	APN922
Carbon.....	APN928
Chai.....	APN912
Cherry.....	APN930
Dark Pewter.....	APN917
Dune.....	APN915
Espresso.....	APN923
Framboise.....	APN931
Frost.....	APN934
Jet.....	APN927
Lawn.....	APN925
Mandarin.....	APN929
Morel.....	APN909
Nimbus.....	APN916
Platinum.....	APN924
Turquoise.....	APN926

BINARY

Blush.....	BNRY12
Coal.....	BNRY06
Cream.....	BNRY01
Denim.....	BNRY08
Diamond.....	BNRY03
Graphite.....	BNRY05
Juniper.....	BNRY10
Lagoon.....	BNRY07
Lavendar.....	BNRY11
Mineral.....	BNRY04
Reef.....	BNRY09
Sand Dollar.....	BNRY02

CIRCUIT

Atlas.....	CIRC35
Dolphin.....	CIRC63
Island White.....	CIRC14
Moon.....	CIRC07
Night.....	CIRC49
Pacific.....	CIRC28
Quartz.....	CIRC01
Sienna.....	CIRC56
Silk.....	CIRC21
Snap Pea.....	CIRC42

ETCH

Axis.....	ECH913
Blend.....	ECH914
Cast.....	ECH912
Highlight.....	ECH910
Midtone.....	ECH911
Outline.....	ECH908
Shade.....	ECH909
Tonal.....	ECH916
Vanish.....	ECH915

EXCHANGE

Iron.....	EXG916
Nickel.....	EXG914
Pistachio.....	EXG910
Root.....	EXG913
Rupee.....	EXG903
Shadow.....	EXG911
Silver.....	EXG915
Sisal.....	EXG917
Stone.....	EXG912

LANDSCAPE

Corn silk.....	LN15
Drift.....	LN05
Khaki.....	LN20
Sheen.....	LN10
Slate.....	LN35
Umber.....	LN25
Urban.....	LN30

GRADE A – continued

LUCY

Aspen.....	LC932
Corn silk.....	LC930
Dusk.....	LC922
Fawn.....	LC933
Graphite.....	LC934
Mist.....	LC920
Neutra.....	LC924
Pewter.....	LC935
Snowdrop.....	LC928

NOBLE

Aspen.....	NBLE14
Bordeaux.....	NBLE01
Brick.....	NBLE02
Chambray.....	NBLE10
Clementine.....	NBLE04
Dawn.....	NBLE13
Denim.....	NBLE09
Grass.....	NBLE07
Gunmetal.....	NBLE15
Harvest.....	NBLE12
Jade.....	NBLE06
Knight.....	NBLE17
Mesa.....	NBLE03
Pacific.....	NBLE08
Rainforest.....	NBLE05
Regal.....	NBLE11
Stormy.....	NBLE16

REFLECTIONS

Galvanized.....	REF929
Ice.....	REF920
Loggia.....	REF921
Mistral.....	REF928
Moonstone.....	REF923
Pewter.....	REF922
Stainless.....	REF924
Vanilla.....	REF925
Winter.....	REF927

REFUGE

Artesian.....	RFG996
Dune.....	RFG992
Eclipse.....	RFG990
Frost.....	RFG993
Glacier.....	RFG991
Mineral.....	RFG998
Tidal.....	RFG994

SARTO

Ash.....	SRT988
Fog.....	SRT914
Lemongrass.....	SRT949
Mist.....	SRT945
Mushroom.....	SRT976
Oyster.....	SRT918
Reef.....	SRT964
Sesame.....	SRT993
Shale.....	SRT952

TEMPEST

Dragonfly.....	TP930
Frost.....	TP915
Full Stream.....	TP980
Gold Rush.....	TP910
Slate.....	TP945
Tumbleweed.....	TP970
Wind Chill.....	TP940
Zebra.....	TP935

GRADE B

COAST

Channel.....	COA914
Dune.....	COA903
Headlands.....	COA910
Marsh.....	COA902
Pebble.....	COA912
Pier.....	COA913
Shoal.....	COA901
Silt.....	COA906
Tide.....	COA908

DISPERSE

Autumn.....	DISP03
Branch.....	DISP10
Coffee Bean.....	DISP13
Dusk.....	DISP09
Emerald City.....	DISP08
Gold Rush.....	DISP02
Igloo.....	DISP11
Ink.....	DISP06
Mist.....	DISP12
Oatmeal.....	DISP15
Prince.....	DISP07
Reservoir.....	DISP01
Rose.....	DISP04
Spring.....	DISP05
Steel.....	DISP16
Taupe.....	DISP14

MICA (De-emphasized)

Anthracite.....	MCA911
Breeze.....	MCA918
Bronze.....	MCA913
Buff.....	MCA914
Cremini.....	MCA917
Crystal.....	MCAWIT
Dew.....	MCA920
Dove.....	MCA912
Fresh.....	MCA916
Mineral.....	MCA915
Nectar.....	MCA919
Shale.....	MCA910

SPIN

Alabaster.....	SPIN02
Cavern.....	SPIN03
Cobblestone.....	SPIN04
Ember.....	SPIN06
Flame.....	SPIN07
Heron.....	SPIN13
Oat.....	SPIN01
Ocean.....	SPIN12
Plum.....	SPIN15
Pool.....	SPIN11
Raven.....	SPIN10
Rhubarb.....	SPIN14
Tropic.....	SPIN08
Willow.....	SPIN05

TERRAIN

Bay.....	TRRN05
Bayou.....	TRRN35
Canyon.....	TRRN30
Cliff.....	TRRN45
Crest.....	TRRN25
Delta.....	TRRN10
Plateau.....	TRRN15
Ridge.....	TRRN20
Valley.....	TRRN40

Partnership Program Upholstery

Beyond®

For use with Solid Wall Tackable Fabric Tiles and Privacy Tile Tackable Fabric Tiles. Blink, Look-see, Medium, Messenger, Milestone, and Walkabout are only available on tiles 48"W or less.

GRADE D

BLINK

Bright Blue.....	1048-59
Dark Violet.....	1048-77
Dove Grey.....	1048-83
Lemon Yellow.....	1048-22
Ocean Blue.....	1048-56
Peppery.....	1048-90
Red Orange.....	1048-44
Sea Green.....	1048-67
Silvery.....	1048-80

LOOK-SEE

Electric.....	1044-77
Foggy.....	1044-85
Foliage.....	1044-67
Lava.....	1044-44
Midnight.....	1044-59
Plum.....	1044-75
Shady.....	1044-80
Snowy.....	1044-11
Stone.....	1044-89
Terra Cotta.....	1044-46
Ultramarine.....	1044-57
Wavelet.....	1044-56
Wine.....	1044-74

MEDIUM

Alloy.....	SMHMMDM03
Blackberry.....	SMHMMDM52
Cascade.....	SMHMMDM51
Cosmic.....	SMHMMDM50
Delight.....	SMHMMDM36
Espresso.....	SMHMMDM07
Flax.....	SMHMMDM04
Hike.....	SMHMMDM47
Laser.....	SMHMMDM14
Marina.....	SMHMMDM22
Nasturtium.....	SMHMMDM53
Nautical.....	SMHMMDM39
Pacific.....	SMHMMDM49
Pecan.....	SMHMMDM08
Persimmon.....	SMHMMDM13
Pistachio.....	SMHMMDM29
Pool.....	SMHMMDM40
Port.....	SMHMMDM16
Prospect.....	SMHMMDM32
Pumpkin.....	SMHMMDM12
Raven.....	SMHMMDM01
Sculpture.....	SMHMMDM45
Smoke.....	SMHMMDM02
Tangle.....	SMHMMDM48
Thatched.....	SMHMMDM46
Washed.....	SMHMMDM44

MESSENGER

Apple.....	SMHMGRM96
Ash.....	SMHMGRM77
Aster.....	SMHMGRM67
Azure.....	SMHMGRM41
Balsa.....	SMHMGRM01
Bayou.....	SMHMGRM08
Beyond.....	SMHMGRM85
Blanch.....	SMHMGRM89
Cactus.....	SMHMGRM45
Capri.....	SMHMGRM61
Cassis.....	SMHMGRM66
Catalyst.....	SMHMGRM98
Cherry.....	SMHMGRM69
Chestnut.....	SMHMGRM52
Chili.....	SMHMGRM83
Cloud.....	SMHMGRM31
Depth.....	SMHMGRM38
Dipper.....	SMHMGRM92
Electric.....	SMHMGRM88
Everglade.....	SMHMGRM87
Fennel.....	SMHMGRM59
Fireside.....	SMHMGRM82
Fossil.....	SMHMGRM76
Gale.....	SMHMGRM93
Hunter.....	SMHMGRM94
Husk.....	SMHMGRM81
Hydrangea.....	SMHMGRM50
Ice.....	SMHMGRM46
Krill.....	SMHMGRM97
Lilac.....	SMHMGRM51
Lime.....	SMHMGRM95
Longspur.....	SMHMGRM90
Lumine.....	SMHMGRM54
Maize.....	SMHMGRM72
Mao.....	SMHMGRM25
Neon.....	SMHMGRM48
Nile.....	SMHMGRM40
Onyx.....	SMHMGRM29
Oyster.....	SMHMGRM79
Pensive.....	SMHMGRM80
Peridot.....	SMHMGRM60
Poppy.....	SMHMGRM24
Robust.....	SMHMGRM84
Satsuma.....	SMHMGRM71
Shadow.....	SMHMGRM07
Snow.....	SMHMGRM58
Spice.....	SMHMGRM68
Squall.....	SMHMGRM63
Tangelo.....	SMHMGRM53
Tobacco.....	SMHMGRM06
Tusk.....	SMHMGRM78
Ultramarine.....	SMHMGRM62
Vibrant.....	SMHMGRM70
Vireo.....	SMHMGRM91
Voyage.....	SMHMGRM86
Zinc.....	SMHMGRM10

MILESTONE

Bison.....	SMHMLSM58
Charcoal.....	SMHMLSM25
Coffee.....	SMHMLSM57
Daffodil.....	SMHMLSM71
Ebony.....	SMHMLSM26
Ecru.....	SMHMLSM72
Embrace.....	SMHMLSM55
Fountain.....	SMHMLSM79
Ground.....	SMHMLSM31
Linger.....	SMHMLSM54
Lychee.....	SMHMLSM69
Mykonos.....	SMHMLSM80
Pewter.....	SMHMLSM22
Rush.....	SMHMLSM47
Spruce.....	SMHMLSM78
Tiger Lily.....	SMHMLSM61
Tortoise.....	SMHMLSM46

WALKABOUT

Alluring Aqua.....	1046-56
Bewitched Blue.....	1046-59
Bold Burgundy.....	1046-74
Classic Cobalt.....	1046-55
Cool Carbon.....	1046-87
Gallant Green.....	1046-67
Gutsy Grey.....	1046-85
Jungly Jade.....	1046-64
Noble Navy.....	1046-58
Peaceful Pewter.....	1046-89
Reliable Red.....	1046-44
Swanky Silver.....	1046-80
Wistful White.....	1046-11

GRADE E

BLAZER LITE

Angel.....	PCAMBLT49
Aspire.....	PCAMBLT52
Balance.....	PCAMBLT41
Bliss.....	PCAMBLT48
Buddha.....	PCAMBLT56
Cuddle.....	PCAMBLT62
Dainty.....	PCAMBLT64
Daydream.....	PCAMBLT46
Devoted.....	PCAMBLT58
Faith.....	PCAMBLT68
Freedom.....	PCAMBLT69
Graceful.....	PCAMBLT51
Happy.....	PCAMBLT55
Harmony.....	PCAMBLT63
Haven*.....	PCAMBLT40
Hope.....	PCAMBLT50
Hush.....	PCAMBLT42
Love.....	PCAMBLT47
Mood.....	PCAMBLT44
Pamper.....	PCAMBLT66
Pastel.....	PCAMBLT65
Pillow.....	PCAMBLT43
Praise.....	PCAMBLT54
Retreat*.....	PCAMBLT39
Shelter.....	PCAMBLT60
Solace*.....	PCAMBLT70
Tender.....	PCAMBLT53
True.....	PCAMBLT61
Verity.....	PCAMBLT57
Wish.....	PCAMBLT67
Worship.....	PCAMBLT59

*Only options for Beyond solid tiles

SPIRAL

Birch.....	PMHMSPL02
Chalk.....	PMHMSPL01
Graphite.....	PMHMSPL06
Mica.....	PMHMSPL04
Pavement.....	PMHMSPL05
Wheat.....	PMHMSPL03

GRADE F

PARALLEL

Argent.....	PMHMPRL02
Boulder.....	PMHMPRL27
Brandy.....	PMHMPRL32
Chalk.....	PMHMPRL01
Crater.....	PMHMPRL33
Fog.....	PMHMPRL03
Linen.....	PMHMPRL23
Pea.....	PMHMPRL24
Quail.....	PMHMPRL36
Shiitake.....	PMHMPRL29
Steam.....	PMHMPRL28
Sterling.....	PMHMPRL22
Wafer.....	PMHMPRL30

ALLSTEEL PARTNERSHIP PROGRAM

Allsteel understands that customers may want to specify panel and seating textiles outside of Allsteel's standard offering. Allsteel's Partnership Program consists of on-trend and design-forward patterns that have been tested and approved by Allsteel for use on Allsteel products. A subset of these approved patterns is available on cards in the textile binder, while numerous others are available on our website, allsteeloffice.com.

For memo samples, please contact our partners:

- Camira, memos@camirafabrics.com 1.616.288.0655
- Carnegie, carnegiefabrics.com 1.800.727.6770
- CF Stinson, cfstinson.com 1.800.841.6279
- HBF Textiles, hbftextiles.com 1.877.494.5727
- Maharam, maharam.com 1.800.645.3943
- Ultrafabrics, ultrafabricsinc.com, 1.877.309.6648

The intent of the Partnership Program is to offer a wide variety of on-trend textiles to meet your varied needs, but since these textiles are not part of our standard offering they may be subject to extended lead times. Because new materials will be introduced regularly, Allsteel reserves the right to change the offering at any time.

Frame & Polymer Finish Matrix

Beyond®

FRAME FINISHES	POLYMER FINISHES
Black P7I	Black E4
Brownstone P7D	Brownstone BW
Bungalow P7C	Warm Tone EF
Carob XP52	Black E4
Champagne Metallic PR5	Warm Tone EF
Cinder P7Q	Brownstone BW
Designer White PJW	Designer White DW
Flint P02	Black E4
Fossil P28	Grey EC
Gunmetal Metallic PR3	Warm Tone EF
Loft P7B	Grey EC
Matte Gold P8G	Black E4
Muslin P4J	Warm Tone EF
Night Bronze P8B	Black E4
Parchment P93	Brownstone BW
Pebble P8R	Grey EC
Pewter P8D	Grey EC
Pyrite PJE	Black E4
Salt P8C	Grey EC
Satin Anodized Aluminum SAL	Grey EC
Silver PR6	Grey EC
Solar Black P8X	Black E4
Textured Brownstone P7J	Brownstone BW
Textured Charblack XCBK	Black E4
Textured Designer White PK7	Designer White DW
Textured Flint P7A	Black E4
Textured Loft P7L	Grey EC
Textured Muslin P7M	Warm Tone EF
Textured Pebble P8Y	Grey EC
Textured Salt P8Z	Grey EC
Textured Titanium P8V	Grey EC
Titanium P8T	Grey EC

BEYOND
TABLE OF CONTENTS

BEYOND
FINISHES & FABRICS

BEYOND
PANELS & TRIM

BEYOND
DOORS

BEYOND
CONNECTORS

BEYOND
ELECTRICAL & DATA

BEYOND
FRAMELESS PRIVACY
TILE SYSTEM

BEYOND
VIZ

Step 1

Confirm seismic design category.

Step 2

Verify that product limitations and site restrictions have been met.

Step 3

Provide architect of record with Beyond's standard seismic package from Allsteel

- Standard package is free
- Stamped drawings available

If local code authority requires additional documentation:

- Trade partners can work with local engineer of record to create a stamped package.
- Note that Allsteel is not responsible for additional costs. It is recommended that trade partners include verbiage in their proposal to the customer that notifies the customer of these additional costs.

The project architect is ultimately responsible for code compliance including seismic requirements.

Allsteel has created guidelines regarding the sale and installation of Beyond in seismic zones. Before selling Beyond in a seismic zone, it's important to know which seismic zone the project is in as well as the building category. Beyond has been evaluated for seismic design categories C-F through a third-party engineering firm, where glass deflection was tested. Product installation is restricted to seismic risk categories I, II and III. Please consult the project architect for more details.

Please contact your Allsteel PM or Wall BDM with further questions.

Anchoring

Beyond must be anchored to the floor and ceiling in seismic areas C-F.

Frameless Panels - Anchoring to Floor and Ceiling:

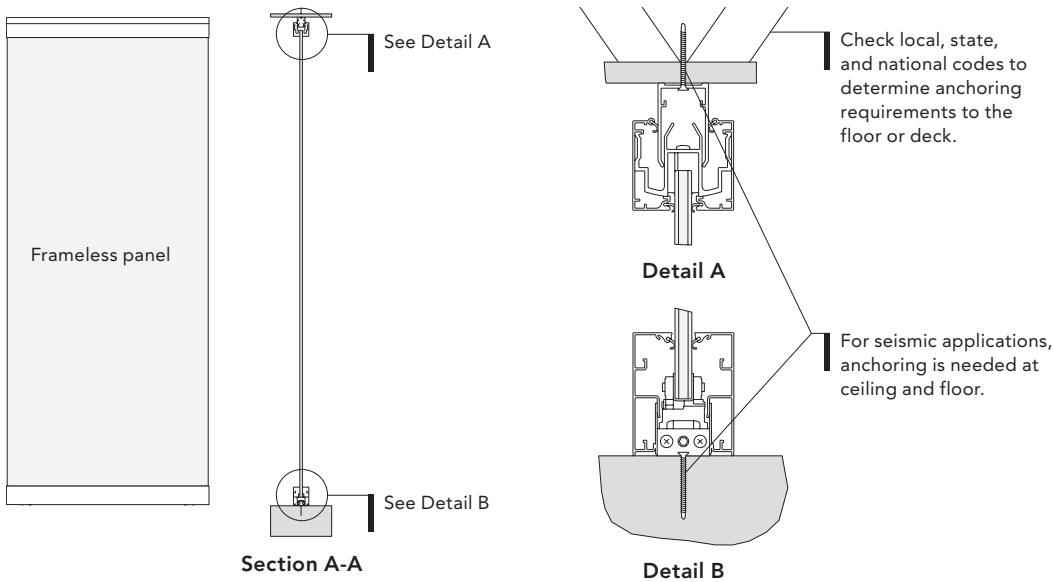

Framed and Solid Panels - Anchoring to Floor and Ceiling:

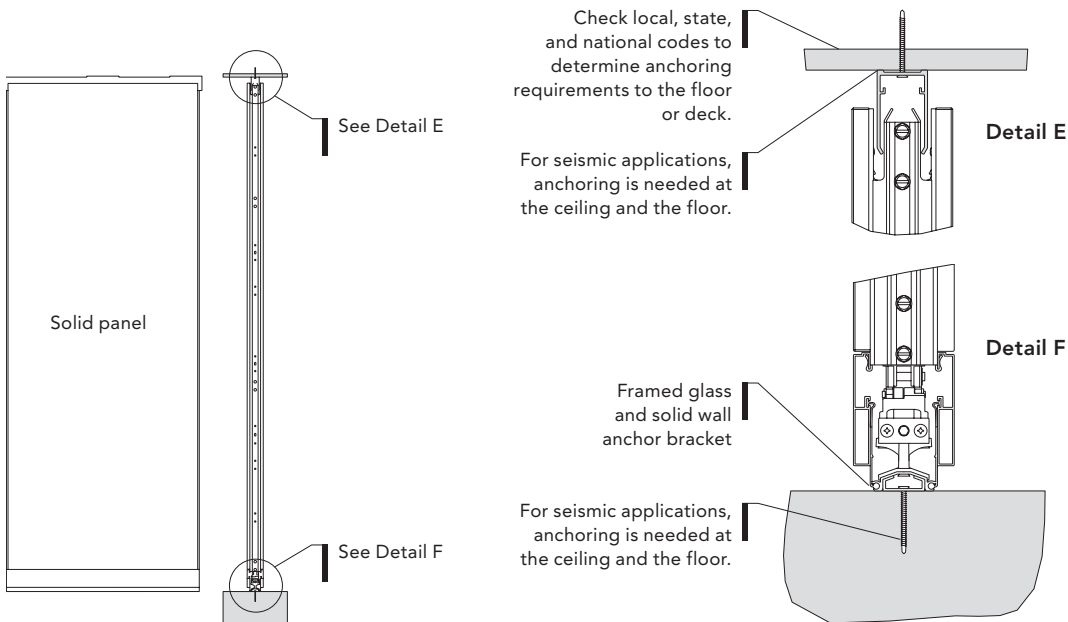

For additional information regarding seismic bracing, please contact your Allsteel PM.

Anchoring

Top and floor anchors are used when required by code or when seismic bracing is needed. In seismic zones C-F, Beyond frameless panels must be anchored to the floor and ceiling. Floor anchors are required on framed and solid panels. Straight top anchors are also used next to doors on frameless wall applications only and are included with the door frame.

Frameless Top Anchors

- Specify QTY (2) straight top anchor per straight vertical filler.
- Specify QTY (1) straight top anchor per three-way vertical filler.
- Specify QTY (1) two-way top anchor per two-way vertical filler.

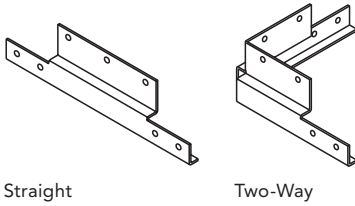

Frameless Floor Anchors

- Specify QTY (1) straight floor anchor per straight vertical filler.
- Specify QTY (1) straight floor anchor per three-way vertical filler.
- Specify QTY (1) two-way floor anchor per two-way vertical filler.
- Specify QTY (1) finished end floor anchor per three-way vertical filler.
- Specify QTY (4) finished end floor anchor per four-way vertical filler.
- Specify QTY (1) finished end floor anchor per frameless wall channel.
- Specify QTY (1) finished end floor anchor per frameless adapter.
- Specify QTY (1) finished end floor anchor per frameless finished end.

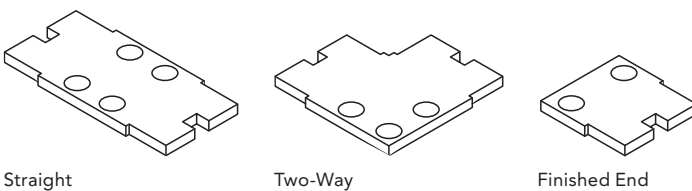

Framed/Solid Floor Anchor

- Specify QTY (1) floor anchor for every 8 linear feet of walls, not including door linear feet.
- Floor anchors interconnect with the base channel.

Product Limitations

Beyond frameless glass walls are seismic qualified up to 114" with no restrictions. For heights above 114", the maximum glass run before requiring additional vertical supports is 126". Vertical supports include wall channels and frameless adapters. Beyond frameless top and floor anchors or 135-degree angles are engineered to order through TPG.

Beyond framed and solid walls are seismic qualified up to 10 feet. Seismic qualification reports with details on required anchorages can be provided upon request.

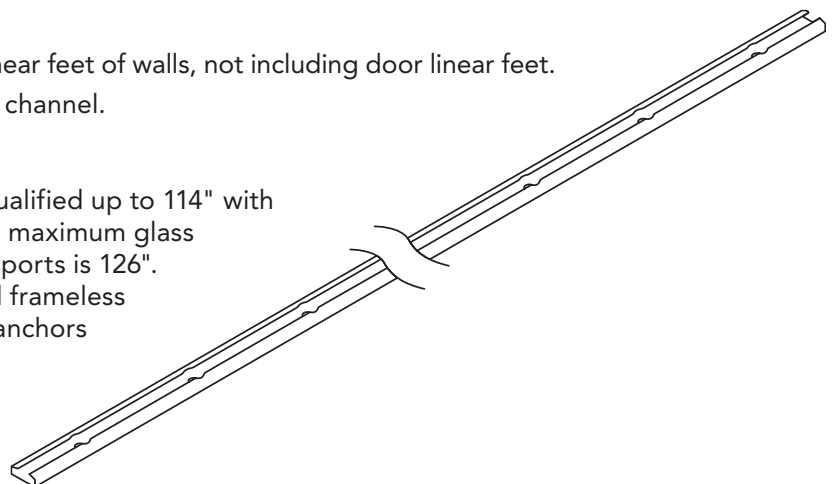

Frameless

Top and Floor Anchors

Details below demonstrate how anchor brackets connect to frameless panels:

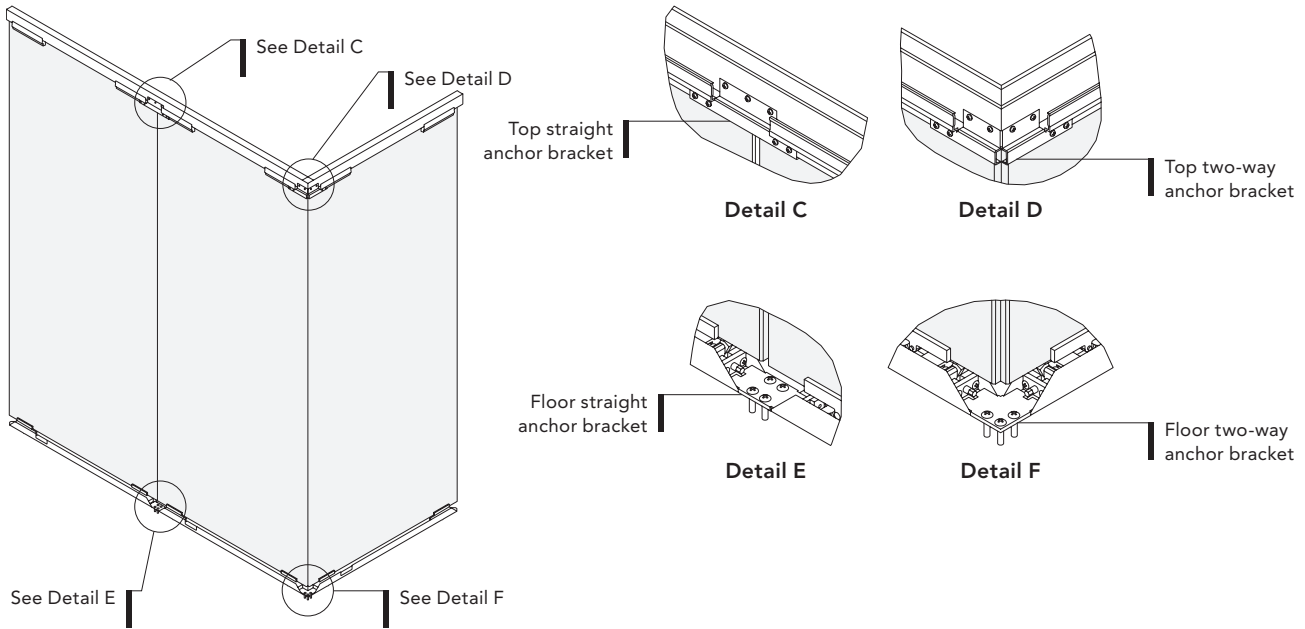

Framed and Solid

Floor Anchors

Details below demonstrate how anchor brackets connect into the floor:

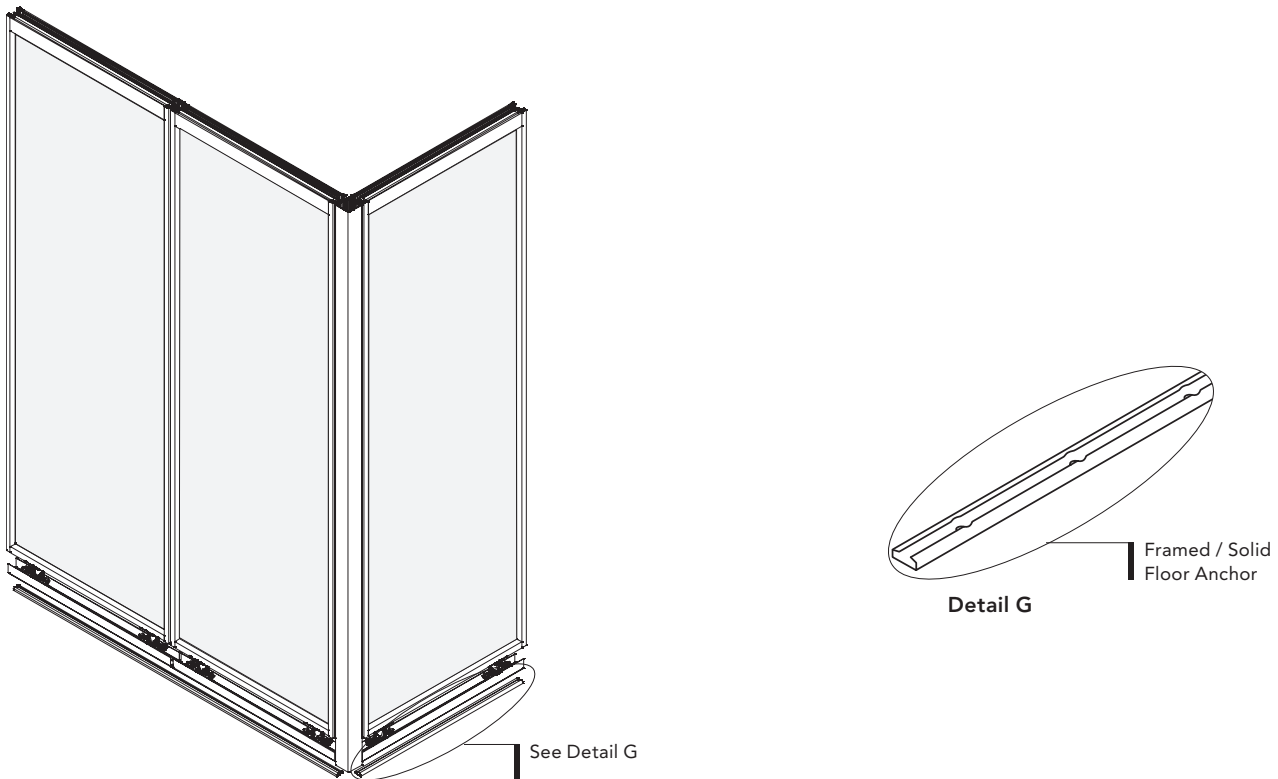

Beyond Freestanding applications include framed, wood slat and solid applications of Beyond including Pavilion and Cabana. Beyond Freestanding applications have been enhanced with new components consisting of hidden internal bracketry, a new cornice and new posts. These new components allow for expanded applications. With unitized panel design, a hidden bracketry solution, and parametric customizable dimensions, these expanded applications no longer need Allsteel engineering review and allow for the creation of the largest single freestanding room.

Freeways can now be specified up to 18 ft and top anchors are no longer needed in seismic design categories C-F. There is also a new power pole option to shroud electrical conduit from above.

Allsteel can provide trade partners with a set of blanket calculations that can be provided to customers. These blanket calculations consist of dozens of modules that were analyzed by a third-party structural engineering firm. These modules can be combined to create hundreds of applications.

To determine seismic risk on your project, enter the project street address into this link: <https://hazards.atcouncil.org/>.

Our product was analyzed per IBC code 1607.15. It was evaluated for 5psf "Wind Load" (A-F) and Seismic Lateral Loading (C-F). One point of mention is that you need to consider this value – S_s . If this value is less than 230%, it means the project site is covered by Allsteel's blanket calculations. If the value is over 230%, it would require site specific analysis.

For project specification, designers should specify the height as they did previously but know that there will be an additional $\frac{7}{8}$ " added to the top of the cornice. The dimension between the floor to top of cornice will be $\frac{7}{8}$ " taller than nominal that is specified. This means you should communicate 13" as the minimum amount of space needed from top of panel ($12\frac{1}{8}$ " from top of cornice) for installation and sprinklers to account for the additional $\frac{7}{8}$ " added to the new cornice.

Seismic post anchors are recommended in some applications in "non-seismic" zones (A-B).

Seismic anchors are required below panels and posts in seismic zones (C-F).

Site specific analysis can be taken on any applications that fall outside of Allsteel's blanket calculations, or if additional documentation is needed by the Engineer of Record in SDC C-F. Please contact your Allsteel PM for more information.

General Specification Notes:

- All doors can now be used with this freestanding solution.
- Furniture hanging on solid panels is allowed
 - Slotted standards are only on solid panels
- Butt-jointed tiles can be specified but will increase steps in installation sequence, adding cost and time to the installation.
- Tiles to the floor can be specified but will also increase steps in installation sequence, adding cost and time to the installation.
- To remove a solid top tile or monolithic tile, the cornice must be removed first due to the z bracket attachment on the back of the tile.
- Any framed/solid wall channel can be used to connect to building interface. Adjustable small wall channel, adjustable large wall channel, and adjacent door wall channel.
- To update a previously existing pavilion, the following components need to be replaced:
 - Freeways
 - Posts
 - Cornice
- The following components can be reused:
 - Panels
 - Doors / door frames / hardware
 - Zippers
 - Trim
 - Wall Channels

Freestanding Cornice

- Beyond freestanding and pavilion applications come with a new cornice.
- New cornice is $\frac{7}{8}$ " taller than the older when installed.
- New cornice is not backwards compatible with older freestanding applications.
- The freestanding cornice should be specified with snap-on trim to conceal all structural bracketry in cases where the freestanding application can be viewed from above. Cornice will default to without snap-on trim in CET.

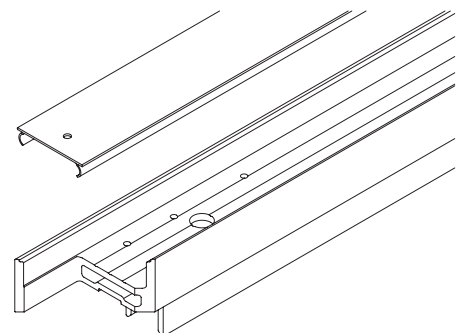

New Cornice + Optional Snap-On Trim

- The new freestanding cornice is designed for use in a straight or 90-degree corner application. The cornice contains a LH and RH pre-mitered corner at each end. Overall length is 10ft.
 - Flat post brackets fit into the cornice profile and reinforce the main corner structure. Flat post brackets should be specified with the freestanding post models.
 - When a straight splice is required at cornice connection points, the cornice can be cut flat and mated to the adjacent cornice. Cutting off the pre-mitered end requires 3" of length removed.
- 20% Scrap should be specified for cornice.
- **No cornice seams should land above double sliding doors in any freestanding application.**

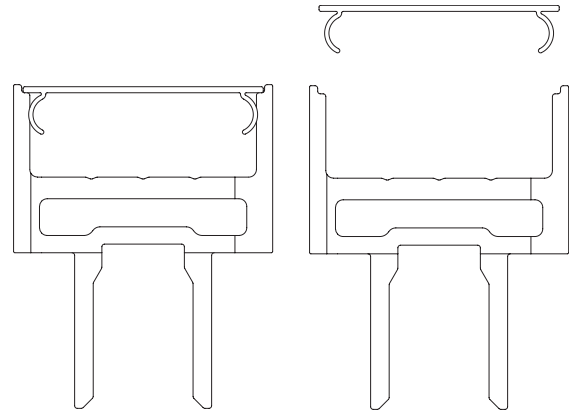

New Cornice + Optional Snap-On Trim
Without Building Interface

- Specify "with building interface" when the freestanding panels are connecting into adjacent building structure.
 - Contains 1 building interface bracket
 - 120"W
 - Any wall start can be utilized. The end of the cornice is notched to avoid interference beyond the panel verticals. The cornice will attach to the building directly, and the wall start is not considered structural.
- Scrap should not be specified for cornice with building interface.

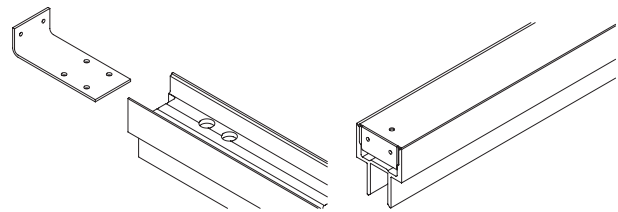

New Cornice + Optional Snap-On Trim
With Building Interface

Panels & Trim

Beyond® — Working with Freestanding

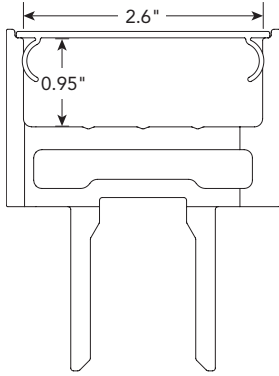

Electrical Routing

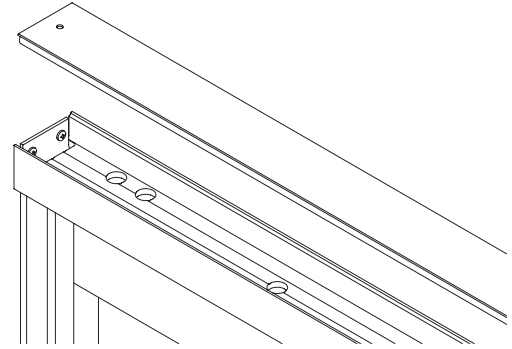

With Building Interface + Optional Snap-On Trim

- There is space for cables in general in the freestanding cornice. The recommendation is to stay within the available cross-sectional areas that could be capped by the cornice cap.

Freestanding Freeway

- Freeway models have been updated from a single piece vertical to vertical post with vertical trim on each side.
- Width is available up to 18ft wide in freestanding applications.
 - <120"W generates 1 horizontal piece.
 - 120"W up to 168"W generates 2 horizontals at 24" and 1 horizontal that varies in width.
 - Over 168"W generates 1 horizontal at 120"W and 2 horizontals that vary in width.
 - All parts will be cut and machined ready to assemble in the field.
 - Freeways longer than 120"W come with splice pieces.

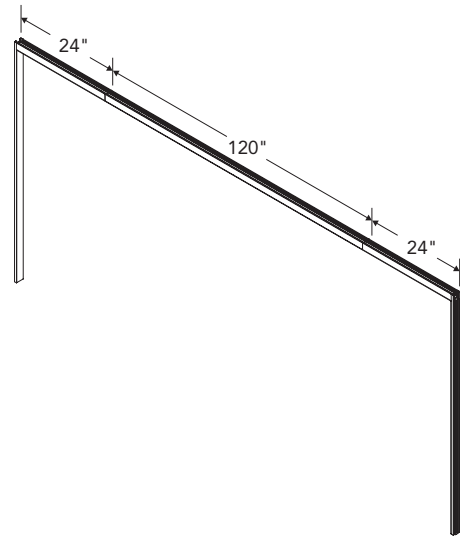

- Vertical components remain with excess length to cut to floor measurements in field.
- BY-FSFREEWAY – Freestanding Freeway – Freeway to be used in freestanding applications. Order with 0, 1 or 2 Freestanding support brackets.
 - Replaces BY-FREEWAY (will be de-emphasized)
- BY-FREEWAYBRK – Freestanding Support Bracket – to be specified with Freeways.
 - Required at any freeway corner that is directly adjacent to a freestanding structural post. Nearly all posts will be structural – exception is in-line application.
- A two-, three- or four-way post in a freestanding application is structural.
 - Brackets will not be supplied for freeway connections that do not land next to a freestanding structural post, and will cause interference if installed adjacent to a solid or framed panel.
 - Freeway tags will indicate where the freeway and bracket variants should go within floor plan.
- Bracket quantities are calculated as follows:
 - If the freeway is not connected to a structural post on either side, no brackets are needed.
 - If the freeway is connected to a structural post on 1 side = 1 bracket
 - If the freeway is connected to a structural post on both sides = 2 brackets
- Freeways can still be specified under ceiling channel. If under ceiling channel, no brackets are needed. Another way to accomplish this detail is to specify finished ends.
- New freestanding freeways are not backwards compatible with older freestanding applications.

Freestanding Freeway
BY-FSFREEWAY

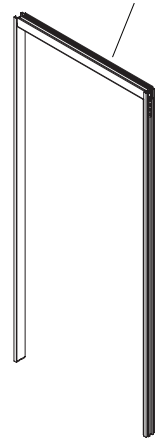

Freestanding Support Bracket
BY-FREEWAYBRK

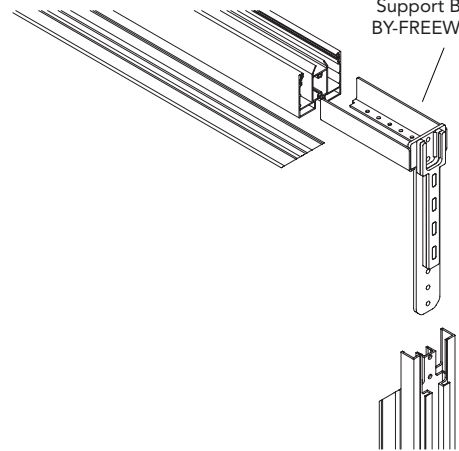

Freestanding Posts

- Two-, three- and four-way freestanding posts are structural. Inline posts are not structural posts.
 - BY-POST – Freestanding Post – Structural post
 - BY-APOST – Beyond Freestanding Post with Access Trim – Structural post
 - Structural posts
 - Structurally attach to floor and to cornice
 - Shipped at nominal heights as specified
 - Three-way contains pre-cut and machined cornice pieces to provide minimal seams. It needs to be specified as with snap-on trim or without snap-on trim.
 - Two-way and three-way posts come with post anchors.
 - BY-PLATE – Freestanding Post Flat Bracket
 - Previously Boomerang Bracket (boomerang bracket to be de-emphasized)
 - Tagged with plan information
- New freestanding posts are not backwards compatible with older freestanding applications.

- Post Anchor Rules
 - Anchors included with all posts
 - Required in SDC C-F
 - Sometimes recommended in SDC A-B.
 - See application rules for more detail.

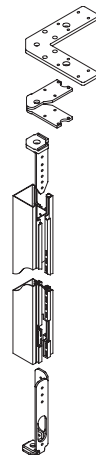

Two-Way Freestanding Post

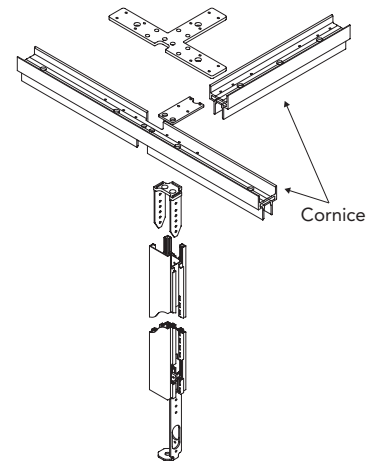

Three-Way Freestanding Post

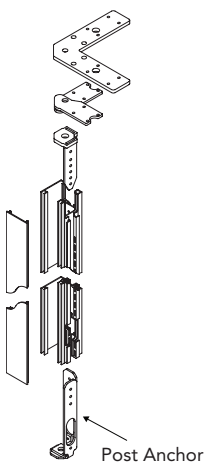

Two-Way Freestanding Post with Access

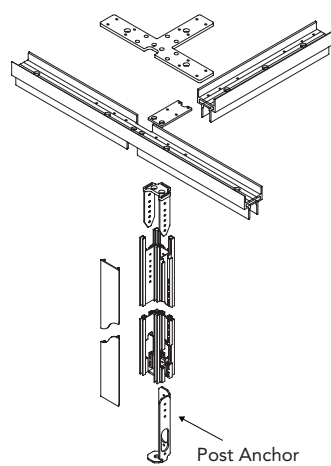

Three-Way Freestanding Post with Access

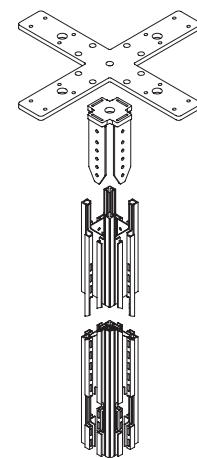

Four-Way Freestanding Post

BEYOND TABLE OF CONTENTS
 BEYOND FINISHES & FABRICS
 BEYOND PANELS & TRIM
 BEYOND DOORS
 BEYOND CONNECTORS
 BEYOND ELECTRICAL & DATA
 BEYOND FRAMELESS PRIVACY TILE SYSTEM
 BEYOND VIZ

- Post Flat Brackets
 - Specified as BY-PLATE
 - Automatically added in CET when a two-, three- or four-way freestanding post is specified
 - Installed at the top of post inside cornice

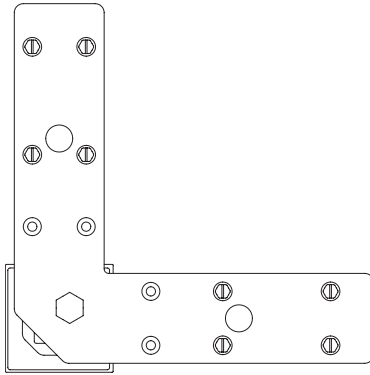
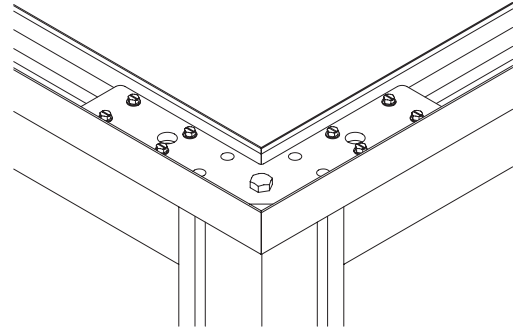

Two-Way Flat Bracket

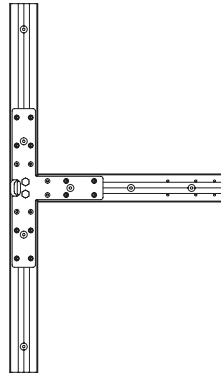

Three-Way Flat Bracket

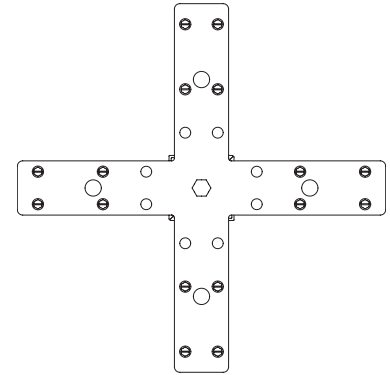

Four-Way Flat Bracket

Freestanding Electrical Routing

- Can use posts or electrical panels to route power up or down
- Electrical panels
 - Cornice may be field drilled up to 1" diameter in alignment with the electrified panel below.
- Posts
 - Beyond in-line standard and access posts may be used anywhere in the middle of a run. These posts are not structural.
 - For an inline post, up to two 1" diameter holes may be drilled through the centerline of the cornice.
 - Freestanding posts contain electrical pass through holes at the base for routing throughout base of the structure.
 - Allsteel recommends using freestanding access posts where routing will go up a structural post.
 - Allows lay in functionality inside post.
 - Prevents any snagging on fasteners if electrical or data were to be pulled through.
- Electrical Pass Through Information
 - Two-way – Clearance for 1 standard conduit pass through at top, 2 conduit pass through at base
 - Three-way – Clearance for 2 standard conduit pass through at top, 2 conduit pass through at base
 - Four-way – Clearance for 2 standard conduit pass through at base. No room for conduits routing up because of four-way flat bracket.

Freestanding Power Pole

- Specified as BY-APOST – Beyond Freestanding Post with Access Trim – Stacking Post = Power Pole
 - Specified as access post with stacking
 - Power poles are non-structural elements used to shroud conduit routings extending upwards. Conduit may extend up without power pole if desired.
 - All power poles are intended to fasten to the freestanding cornice and have features to self fixture into place.
 - 5'H only.
 - Straight option is not intended for above structural posts (two-, three- or four-way), and should be offset at least 12" to CL of structural post.
 - Power pole is a new type of Infeed.
 - Power pole is fastened to the cornice with supplied hardware, and to the deck above with hardware supplied by others.
 - If 5'H power pole is not tall enough, the equivalent stacker post (2-way, 3-way, inline) can be ordered and spliced in. Need to use the top mounting bracket from the power pole model at the top.

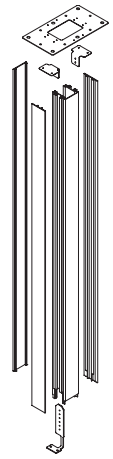
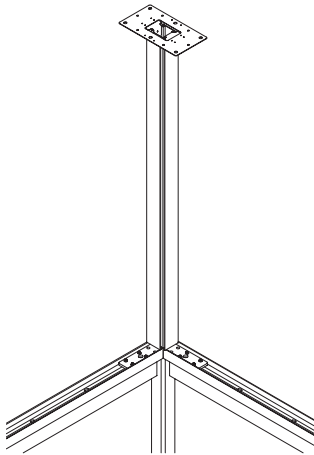

Straight

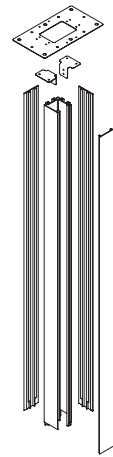

Two-Way

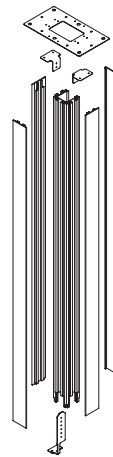

Three-Way

General Guidelines

- The following typicals consist of panels, freeways, or doors between **4 structural posts**. They are labeled as modules. It is recommended that all A-B modules are anchored into the floor at posts, unless otherwise noted. **The exception is 4-sided room modules – posts do NOT need to be anchored.**
- All framed glass types are possible in SDC A-B.
- Maximum height is 120"H unless otherwise noted.
- Minimum height is 86" due to clearance needed for freeways and doors to meet 80"H clear opening.
- Panel runs are 24"W minimum (27.5" CL TO CL) for four-sided modules.
- All modules can connect at structural posts in any direction.
- ALL DIMENSIONS ARE LENGTH MAXIMUMS UNLESS OTHERWISE NOTED.
- If Worksurface Mounting, worksurfaces must be \leq 135lbs self weight at 42" AFF (60" x 72" worksurface max).
- If TV Mounting, TVs must be \leq 170lbs at \leq 78" AFF, no pivot or articulating / extending arm allowed. 1 TV allowed per module. If you have multiple modules connected, TVs are allowed to be back to back.
- **Only a framed/solid run can be replaced with drywall. Reference the orange dots in the modules.**
 - If drywall is acting as one of the 4 walls of a module, the perpendicular walls coming off the drywall should follow the rules of a framed/solid run. Find the correct module that applies with those walls as framed/solid runs.
 - A post to post freeway or wood slat run perpendicular to drywall should follow the rules of a framed/solid run.

SDC A-B: Freestanding Panel Module Possibilities

1. Standalone - 2 Framed / Solid Panel Runs between 2 Freeways
2. Connected - 2 Framed / Solid Panel Runs between 2 Freeways
3. Standalone - 1 Framed / Solid Panel Run with 3 Freeways
4. Connected - 1 Framed / Solid Panel Run with 3 Freeways
5. Standalone - L-Configured Framed / Solid Panel Runs with 2 Freeways
6. Connected - L-Configured Framed / Solid Panel Runs with 2 Freeways
7. Standalone - 4 Freeways
8. Connected - 4 Freeways
9. Standalone - 3 Framed / Solid Panel Runs with 1 Freeway, Single Door
10. Connected - 3 Framed / Solid Panel Runs with 1 Freeway, Single Door
11. Standalone - 3 Framed / Solid Panel Runs with 1 Freeway, Double Door & 48"W Door
12. Connected - 3 Framed / Solid Panel Runs with 1 Freeway, Double Door & 48"W Door
13. Standalone - 3 Framed / Solid Panel Runs with 1 Freeway, Freeway over 42"W
14. Connected - 3 Framed / Solid Panel Runs with 1 Freeway, Freeway over 42"W
15. Standalone - 4 Framed / Solid Panel Runs and Phone booth, Single Door
16. Connected - 4 Framed / Solid Panel Runs and Phone booth, Single Door
17. Standalone - 4 Framed / Solid Panel Runs and Phone booth, Double Door & 48"W Door
18. Connected - 4 Framed / Solid Panel Runs and Phone booth, Double Door & 48"W Door
19. Standalone - 4 Framed / Solid Panel Runs and Phone booth, Freeway over 42"W
20. Connected - 4 Framed / Solid Panel Runs and Phone booth, Freeway over 42"W
21. Standalone - 1 Framed / Solid Panel Run between Building Structure

Panels & Trim

Beyond® — Working with Freestanding: SDC A-B

1. Standalone

2 Framed / Solid Panel Runs between
2 Freeways

- If this module is standalone as shown:
 - Panels can be specified up to 144"W.
 - Freeways can be specified up to 216"W.
- If using solid panels or posts:
 - Worksurface – anywhere along run (solid panels only)
 - TV – anywhere along run (solid panels or posts)
 - Framed / Solid run can be replaced with drywall

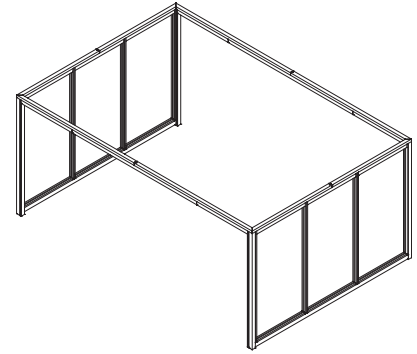
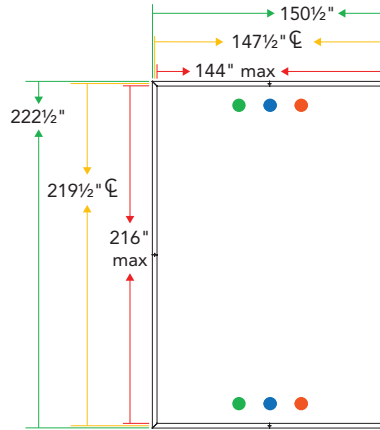

2. Connected

2 Framed / Solid Panel Runs between
2 Freeways

- If this module is connected to other modules on any side:
 - The framed / solid panels are limited to 80"W maximum.
 - Freeways can be specified up to 216"W.
- If using solid panels or posts:
 - Worksurface – anywhere along run (solid panels only)
 - TV – anywhere along run (solid panels or posts)
 - Framed / Solid run can be replaced with drywall

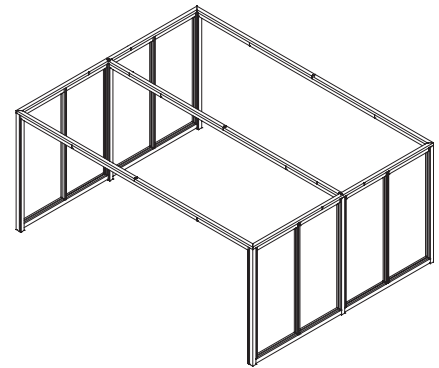
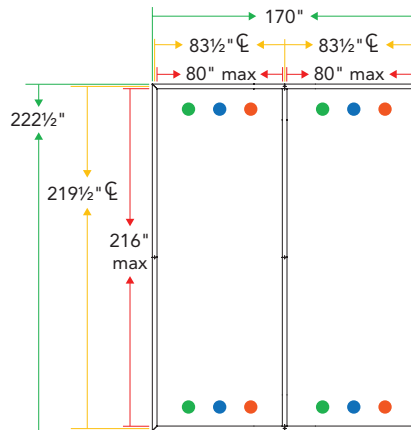

3. Standalone

1 Framed / Solid Panel Run with 3 Freeways

- If this module is standalone as shown:
 - Panels can be specified up to 144"W.
 - Freeway opposite panels can be specified up to 144"W.
 - Freeways perpendicular to panels can be specified up to 216"W.
- If using solid panels or posts:
 - Worksurface – anywhere along run (solid panels only)
 - TV – anywhere along run (solid panels or posts)
 - Framed / Solid run can be replaced with drywall

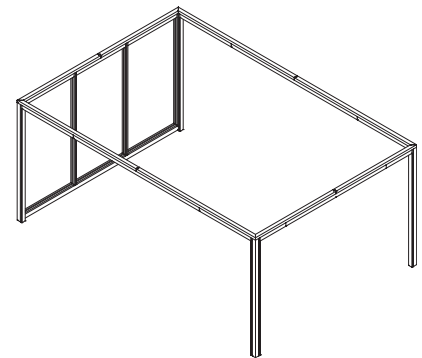
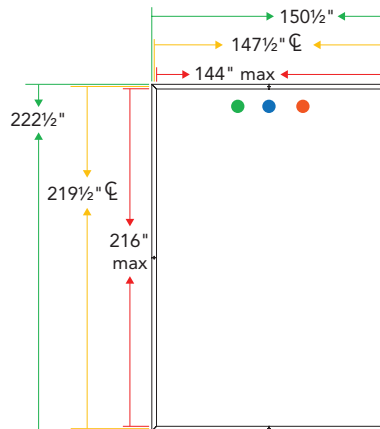

4. Connected

1 Framed / Solid Panel Run with
3 Freeways

- If this module is connected to other modules on any side:
 - The framed / solid panel runs are limited to 80"W maximum.
 - Freeways opposite to panels can be specified up to 80"W.
 - Freeways perpendicular to panels can be specified up to 216"W.
- If using solid panels or posts:
 - Worksurface – anywhere along run (solid panels only)
 - TV – anywhere along run (solid panels or posts)
 - Framed / Solid run can be replaced with drywall

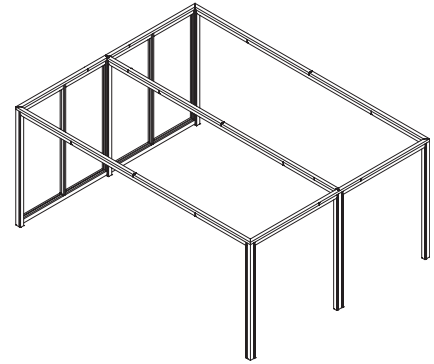
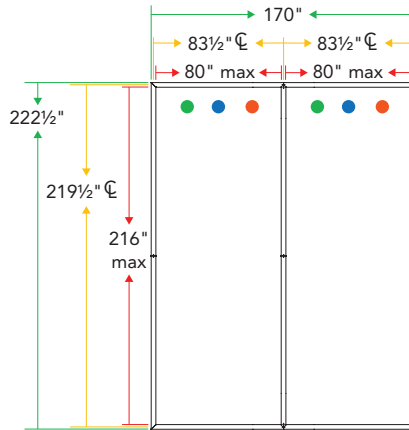

5. Standalone

L-Configured Framed / Solid Panel Runs with
2 Freeways

- If this module is standalone as shown:
 - Panels can be specified up to 144"W.
 - Freeways can be specified up to 144"W.
- If using solid panels or posts:
 - Worksurface – anywhere along run (solid panels only)
 - TV – anywhere along run (solid panels or posts)
 - Framed / Solid run can be replaced with drywall

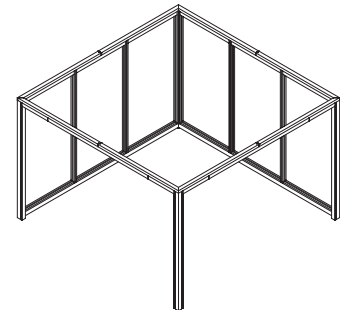
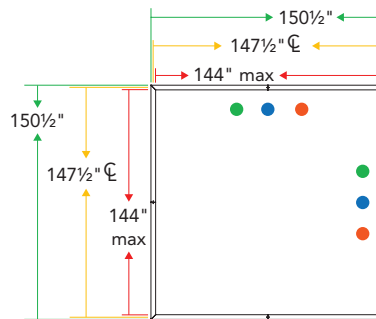

6. Connected

L-Configured Framed / Solid Panel Runs with
2 Freeways

- If this module is connected to other modules on any side:
 - The framed / solid panels are limited to 144"W maximum.
 - Freeways can be specified up to 144"W.
- If using solid panels or posts:
 - Worksurface – anywhere along run (solid panels only)
 - TV – anywhere along run (solid panels or posts)
 - Framed / Solid run can be replaced with drywall

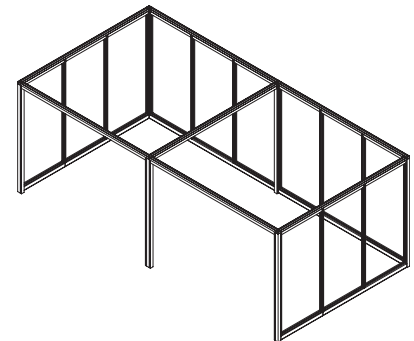
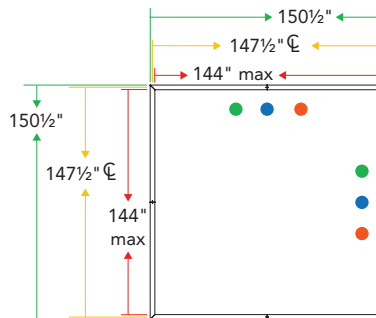

Panels & Trim

7. Standalone 4 Freeways

- If this module is standalone as shown:
 - Freeways can be specified up to 216"W.
 - No worksurface or TV mounting allowed.

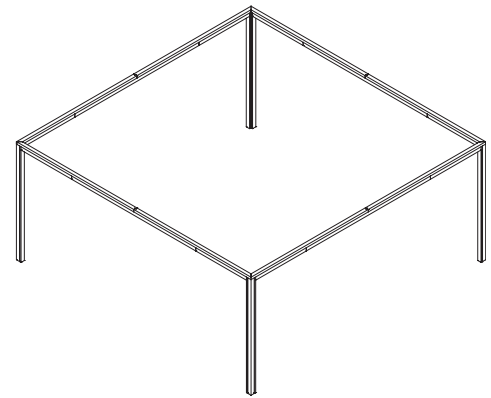
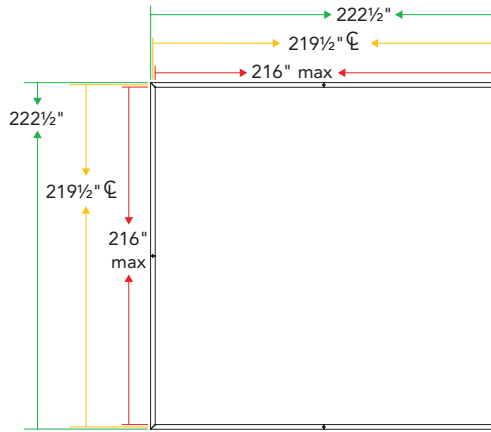

8. Connected 4 Freeways

- If this module is connected to other modules on any side:
 - Freeways can be specified up to 216"W.
 - No worksurface or TV mounting allowed.

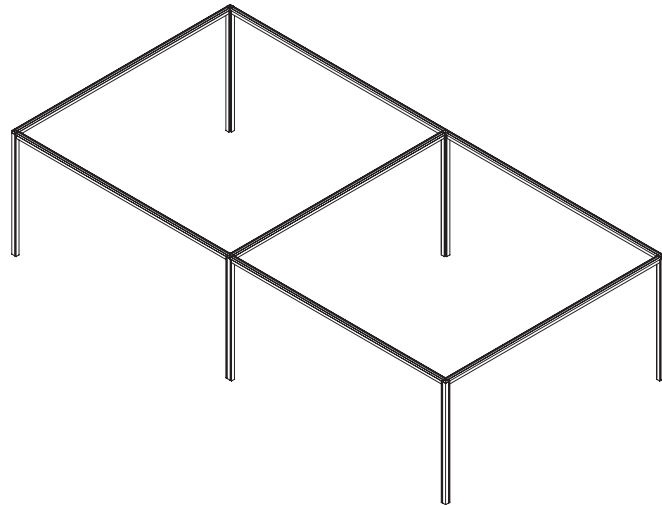
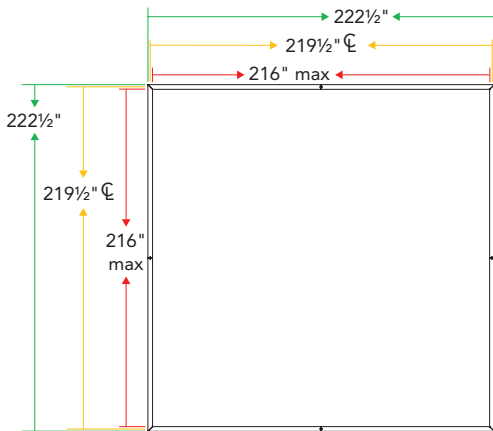

9. Standalone

3 Framed / Solid Panel Runs with 1 Freeway
– SINGLE DOOR

- If this module is standalone as shown:
 - Panel run with door can be specified up to 216"W.
 - Panel runs perpendicular to door can be specified up to 144"W.
 - Freeway can be specified up to 216"W.
 - Single door or freeway up to 42"W can be added to 216" max panel run.
 - Must have minimum 9"W wing panel adjacent to post on one side within run with door.
- If using solid panels or posts:
 - Worksurface – anywhere along run (solid panels only)
 - TV – anywhere along run (solid panels or posts)
 - Overhead – mount anywhere along run (solid panels only)
 - Framed / Solid run can be replaced with drywall

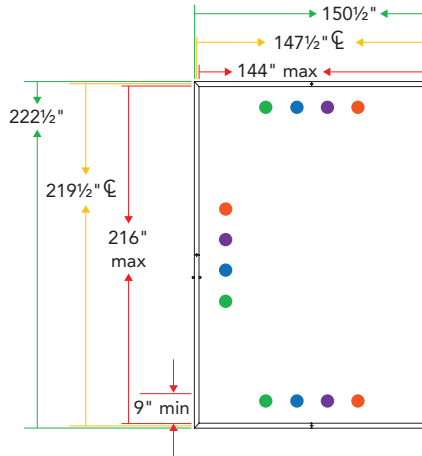

Absolute minimums –
for illustrative purposes

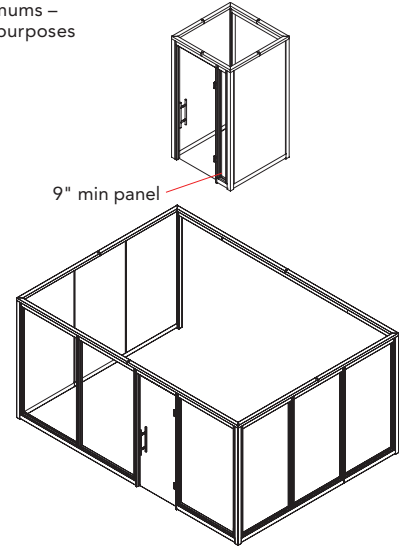

10. Connected

3 Framed / Solid Panel Runs with
1 Freeway – SINGLE DOOR

- If this module is connected to other modules on any side:
 - Panel run with door can be specified up to 216"W.
 - Panel runs perpendicular to door can be specified up to 144"W.
 - Freeway can be specified up to 216"W.
 - Single door or freeway up to 42"W can be added to 216" max panel run.
 - Must have minimum 9"W wing panel adjacent to post on one side within run with door.
- If using solid panels or posts:
 - Worksurface – anywhere along run (solid panels only)
 - TV – anywhere along run (solid panels or posts)
 - Overhead – mount anywhere along run (solid panels only)
 - Framed / Solid run can be replaced with drywall

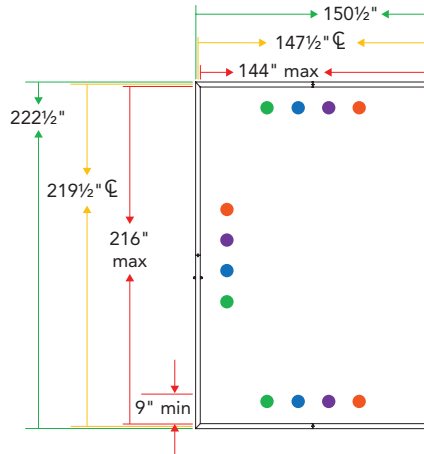

9" min panel

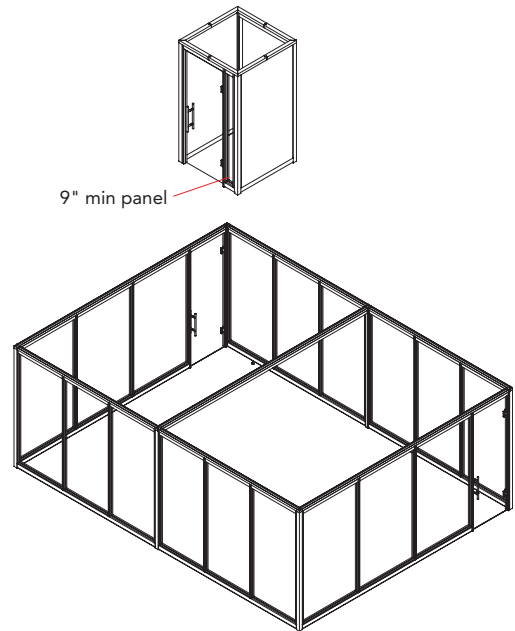

Panels & Trim

11. Standalone

3 Framed / Solid Panel Runs with
 1 Freeway – DOUBLE DOOR &
 48"W DOOR

- If this module is standalone as shown:
 - Panel run with door can be specified up to 216"W.
 - Panel runs perpendicular to door can be specified up to 144"W.
 - Freeway can be specified up to 216"W.
 - A double door or 48"W door can be added to 216" max panel run.
 - Must have 38"W framed / solid wing wall at 1 post and additional 38"W framed / solid minimum wall within run with door.
- If using solid panels or posts:
 - Worksurface – anywhere along run (solid panels only)
 - TV – anywhere along run (solid panels or posts)
 - Overhead – mount anywhere along run (solid panels only)
 - Framed / Solid run can be replaced with drywall

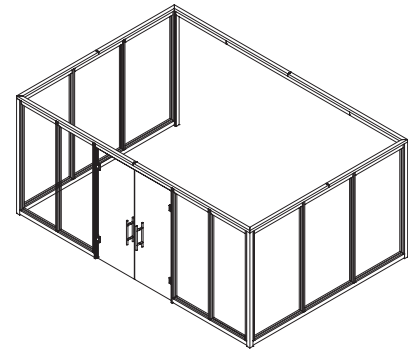
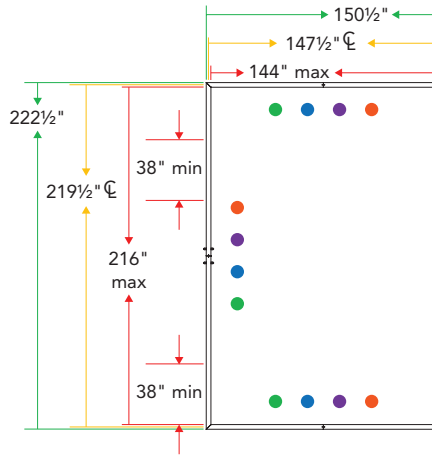

12. Connected

3 Framed / Solid Panel Runs with
 1 Freeway – DOUBLE DOOR &
 48"W DOOR

- If this module is connected to other modules on any side:
 - Panel run with door can be specified up to 216"W.
 - Panel runs perpendicular to door can be specified up to 144"W.
 - Freeway can be specified up to 216"W.
 - A double door or 48"W door can be added to 216" max panel run.
 - Must have 38"W framed / solid wing wall at 1 post and additional 38"W framed / solid minimum wall within run with door.
- If using solid panels or posts:
 - Worksurface – anywhere along run (solid panels only)
 - TV – anywhere along run (solid panels or posts)
 - Overhead – mount anywhere along run (solid panels only)
 - Framed / Solid run can be replaced with drywall

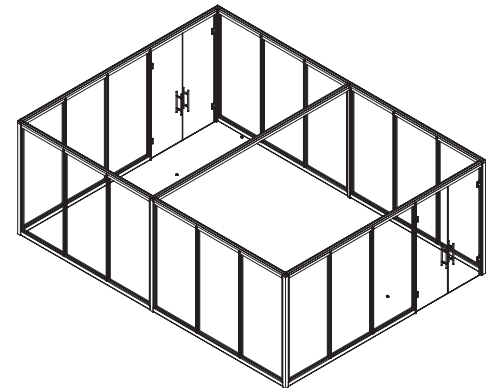
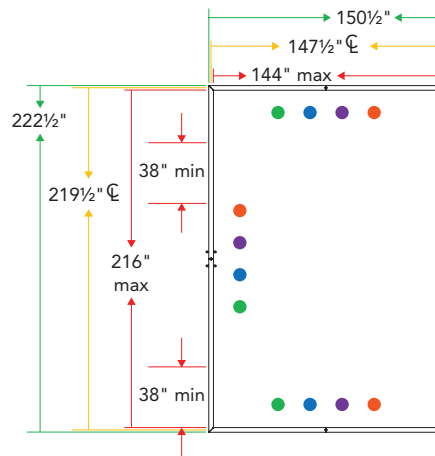

13. Standalone

3 Framed / Solid Panel Runs with 1 Freeway – FREEWAY over 42"W

- If this module is standalone as shown:
 - Panel run with freeway and wing panel can be specified up to 216"W.
 - Panel runs perpendicular to freeway with wing panel can be specified up to 144"W.
 - Post to post freeway can be specified up to 216"W.
 - Freeway with wing panel can only be added to 216" max panel run. Must have 38"W framed / solid wing wall at 1 post and additional 38"W framed / solid minimum wall within run.
- If using solid panels or posts:
 - Worksurface – anywhere along run (solid panels only)
 - TV – anywhere along run (solid panels or posts)
 - Overhead – mount anywhere along run (solid panels only)
 - Framed / Solid run can be replaced with drywall

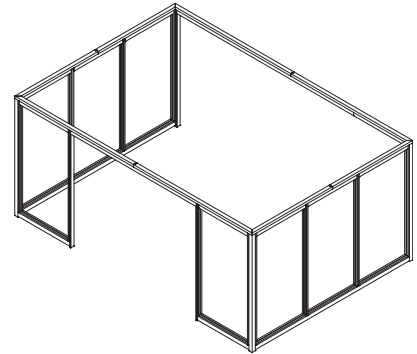
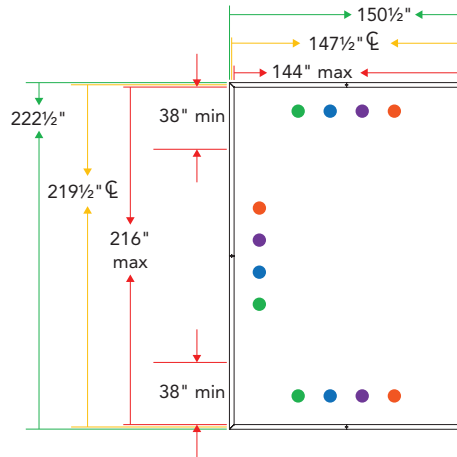

14. Connected

3 Framed / Solid Panel Runs with 1 Freeway – FREEWAY over 42"W

- If this module is connected to other modules on any side:
 - Panel run with freeway and wing panel can be specified up to 216"W.
 - Panel runs perpendicular to freeway with wing panel can be specified up to 144"W.
 - Post to post freeway can be specified up to 216"W.
 - Freeway with wing panel can only be added to 216" max panel run. Must have 38"W framed / solid wing wall at 1 post and additional 38"W framed / solid minimum wall within run.
- If using solid panels or posts:
 - Worksurface – anywhere along run (solid panels only)
 - TV – anywhere along run (solid panels or posts)
 - Overhead – mount anywhere along run (solid panels only)
 - Framed / Solid run can be replaced with drywall

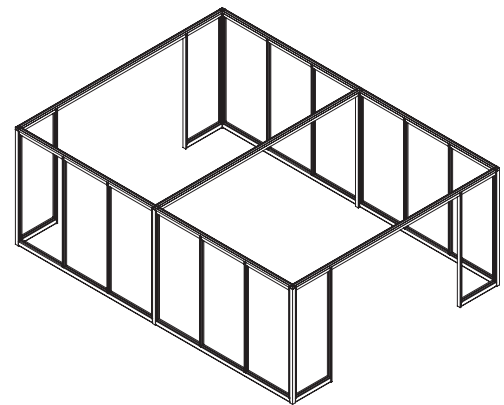
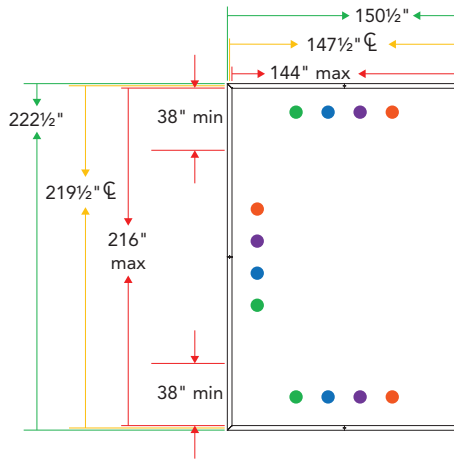

Panels & Trim

15. Standalone

4 Framed / Solid Panel
 Runs and Phone Booth
 – SINGLE DOOR

• If this module is standalone as shown:

- Panel runs can be specified up to 204"W.
- Single door or freeway up to 42"W can be added to any panel run.
- Must have minimum 9"W wing panel adjacent to post on one side within run with door.
- 1 door allowed per module.

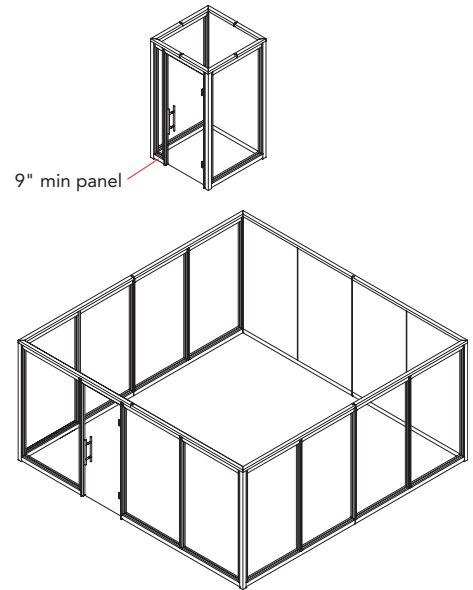
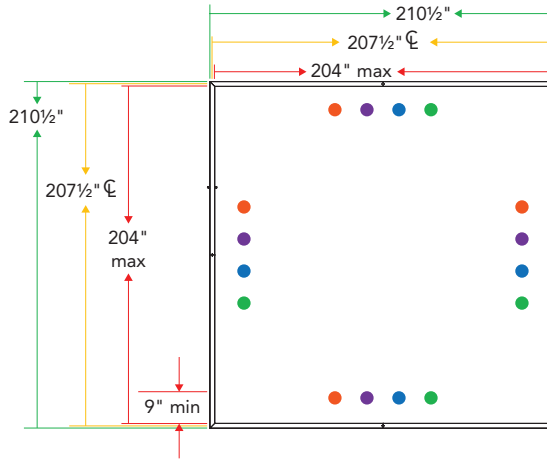

• If using solid panels or posts:

- Worksurface – anywhere along run (solid panels only)
- TV – anywhere along run (solid panels or posts)
- Overhead – mount anywhere along run (solid panels only)
- Framed / Solid run can be replaced with drywall

16. Connected

4 Framed / Solid Panel Runs and Phone Booth – SINGLE DOOR

- If this module is connected to other modules on any side:
 - Panel runs can be specified up to 204"W.
 - Single door or freeway up to 42"W can be added to any panel run.
 - Must have minimum 9"W wing panel adjacent to post on one side within run with door.
 - 1 door allowed per module.

• If using solid panels or posts:

- Worksurface – anywhere along run (solid panels only)
- TV – anywhere along run (solid panels or posts)
- Overhead – mount anywhere along run (solid panels only)
- Framed / Solid run can be replaced with drywall

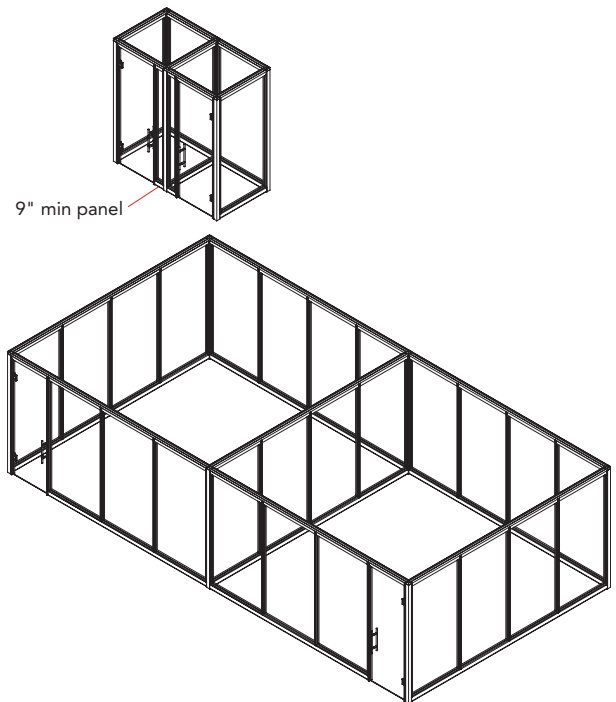
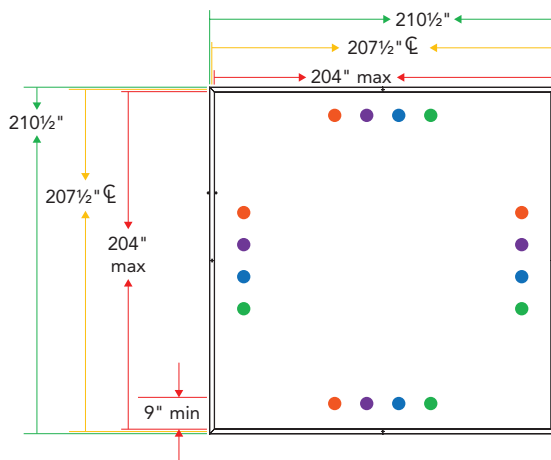

17. Standalone

4 Framed / Solid Panel Runs and Phone Booth – DOUBLE DOOR & 48"W DOOR

- If this module is standalone as shown:
 - Panel runs can be specified up to 204"W.
 - A double door or 48"W door can be added to any panel run.
 - Must have 38"W framed / solid wing wall at 1 post and additional 38"W framed / solid minimum wall within run with door.
 - 1 door allowed per module.
- If using solid panels or posts:
 - Worksurface – anywhere along run (solid panels only)
 - TV – anywhere along run (solid panels or posts)
 - Overhead – mount anywhere along run (solid panels only)
 - Framed / Solid run can be replaced with drywall

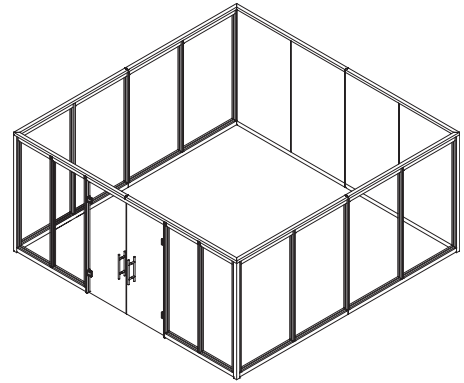
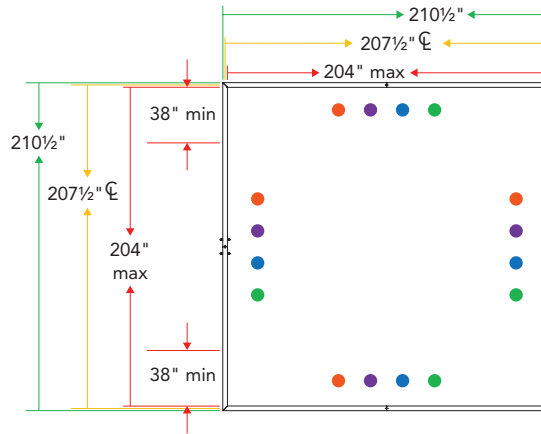

18. Connected

4 Framed / Solid Panel Runs and Phone Booth – DOUBLE DOOR & 48"W DOOR

- If this module is connected to other modules on any side:
 - Panel runs can be specified up to 204"W.
 - A double door or 48"W door can be added to any panel run.
 - Must have 38"W framed / solid wing wall at 1 post and additional 38"W framed / solid minimum wall within run with door.
 - 1 door allowed per module.
- If using solid panels or posts:
 - Worksurface – anywhere along run (solid panels only)
 - TV – anywhere along run (solid panels or posts)
 - Overhead – mount anywhere along run (solid panels only)
 - Framed / Solid run can be replaced with drywall

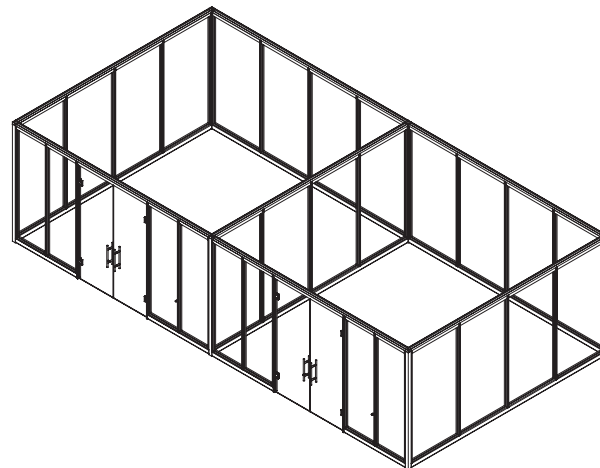
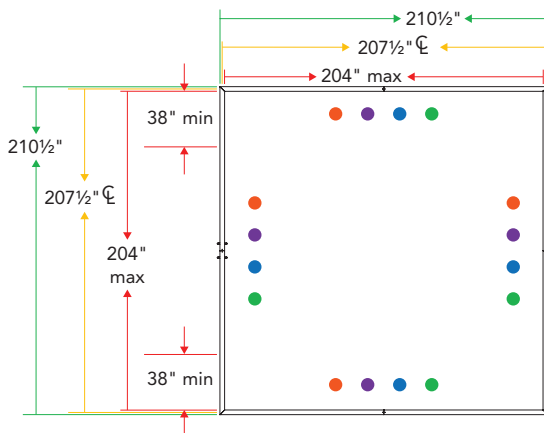

Panels & Trim

19. Standalone

4 Framed / Solid Panel Runs and Phone Booth – FREEWAY over 42"W

- If this module is standalone as shown:
 - Panel runs can be specified up to 204"W.
 - A freeway over 42"W can be added to any panel run.
 - Must have 38"W framed / solid wing wall at 1 post and additional 38"W framed / solid minimum wall within run with freeway.
 - 1 freeway allowed per module.
- If using solid panels or posts:
 - Worksurface – anywhere along run (solid panels only)
 - TV – anywhere along run (solid panels or posts)
 - Overhead – mount anywhere along run (solid panels only)
 - Framed / Solid run can be replaced with drywall

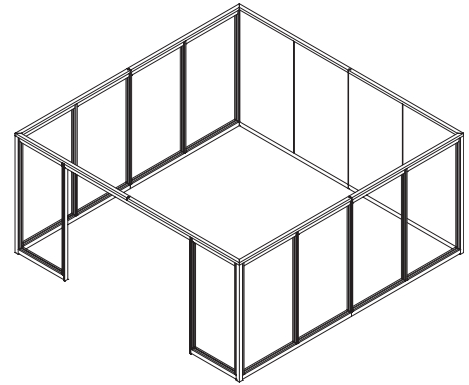
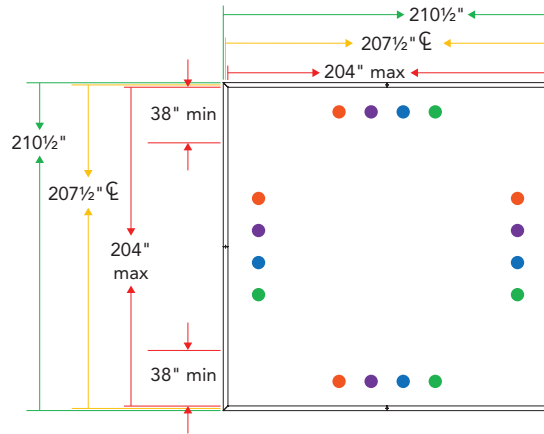

20. Connected

4 Framed / Solid Panel Runs and Phone Booth – FREEWAY over 42"W

- If this module is connected to other modules on any side:
 - Panel runs can be specified up to 204"W.
 - A freeway over 42"W can be added to any panel run.
 - Must have 38"W framed / solid wing wall at 1 post and additional 38"W framed / solid minimum wall within run with freeway.
 - 1 freeway allowed per module.
- If using solid panels or posts:
 - Worksurface – anywhere along run (solid panels only)
 - TV – anywhere along run (solid panels or posts)
 - Overhead – mount anywhere along run (solid panels only)
 - Framed / Solid run can be replaced with drywall

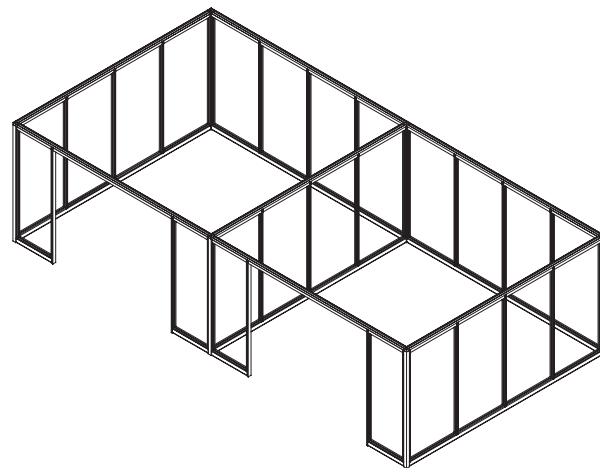
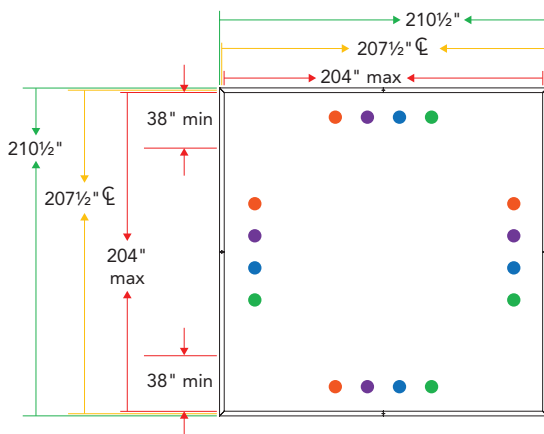

21. Standalone

1 Framed / Solid Panel Run between Building Structure

- Any size door or freeway can be added anywhere within the run.
- 216"W freeway is possible if desired.
- 1 door or freeway allowed per module.
- No worksurface or TV mounting allowed.

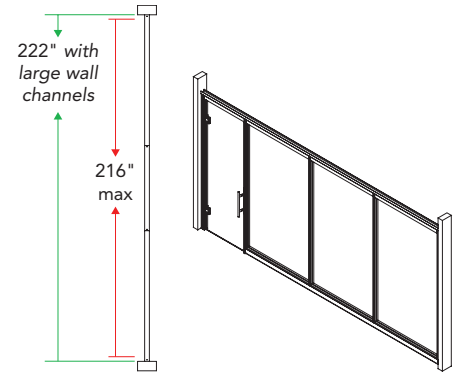

General Guidelines

- The following typicals consist of panels, freeways, doors and wood slat panels between 4 structural posts. They are labeled as modules. It is recommended that all A-B modules are anchored into the floor at posts, unless otherwise noted. **The exception is 4-sided room modules – posts do NOT need to be anchored.**
- Maximum height varies – some modules are limited to 96"H; others can go to 120"H.
- Minimum height is 86" due to clearance needed for freeways and doors to meet 80"H clear opening.
- Panel runs are limited to 24"W minimum – (27.5" CL TO CL) for four-sided modules.
- All modules can connect at structural posts in any direction.
- ALL DIMENSIONS ARE LENGTH MAXIMUMS UNLESS OTHERWISE NOTED.
- If Worksurface Mounting, worksurfaces must be \leq 135lbs self weight at 42" AFF (60" x 72" worksurface max).
- If TV Mounting, TVs must be \leq 170lbs at \leq 78" AFF, no pivot or articulating / extending arm allowed. 1 TV allowed per module. If you have multiple modules connected, TVs are allowed to be back to back.
- Wood slat panel standard special sizes reminder:
 - Widths: 24"W, 30"W, 36"W, 42"W, 48"W
 - Heights: 96"H, 102"H, 108"H, 112"H, 120"H
- Applications with wood slat runs connecting at a 2-way post will always require site specific calculations. These applications are not covered in Allsteel's blanket calculations.
- **Only a framed/solid run can be replaced with drywall. Reference the orange dots in the modules.**
 - If drywall is acting as one of the 4 walls of a module, the perpendicular walls coming off the drywall should follow the rules of a framed/solid run. Find the correct module that applies with those walls as framed/solid runs.
 - A post to post freeway or wood slat run perpendicular to drywall should follow the rules of a framed/solid run.

SDC A-B: Freestanding Panel Module Possibilities

22. Standalone - 2 Wood Slat Runs between 2 Freeways
23. Connected - 2 Wood Slat Runs between 2 Freeways
24. Standalone - 1 Wood Slat Run and 1 Framed / Solid Panel Run between 2 Freeways
25. Connected - 1 Wood Slat Run and 1 Framed / Solid Panel Run between 2 Freeways
26. Standalone - 1 Wood Slat Run with 3 Freeways
27. Connected - 1 Wood Slat Run with 3 Freeways
28. Standalone - 2 Framed / Solid Panel Runs between 1 Wood Slat Run and 1 Freeway
29. Connected - 2 Framed / Solid Panel Runs between 1 Wood Slat Run and 1 Freeway
30. Standalone - L-Configured Framed / Solid Panel Run and Wood Slat Run with 2 Freeways
31. Connected - L-Configured Framed / Solid Panel Run and Wood Slat Run with 2 Freeways

Panels & Trim

Beyond® — Working with Freestanding & Wood Slats: SDC A-B

22. Standalone

2 Wood Slat Runs between 2 Freeways

- If this module is standalone as shown:
 - Wood slat runs can be specified up to 144"W.
 - Freeways can be specified up to 216"W.
 - 120"H Max
- Wood Slat Planning: 48"W x 3 = 144"W
- If using inline posts:
 - TV – anywhere along run

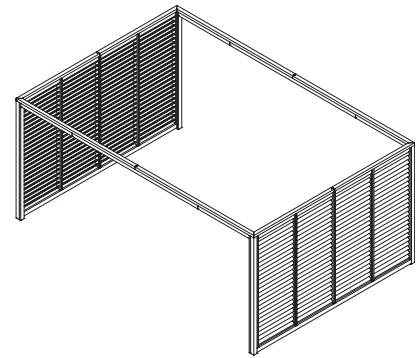
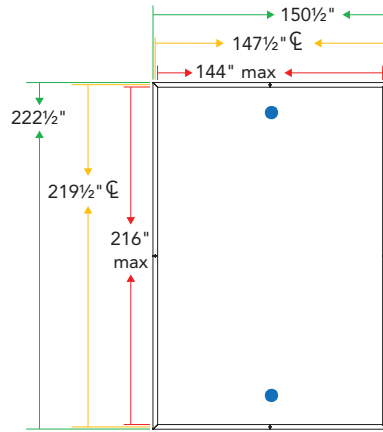

23. Connected

2 Wood Slat Runs between 2 Freeways

- If this module is connected to other modules on any side:
 - Wood slat runs can be specified up to 80"W.
 - Freeways can be specified up to 216"W.
 - 120"H Max
- Wood Slat Planning: 42"W + 36"W = 78"W
- If using inline posts:
 - TV – anywhere along run

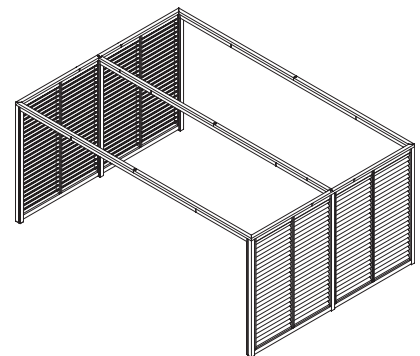
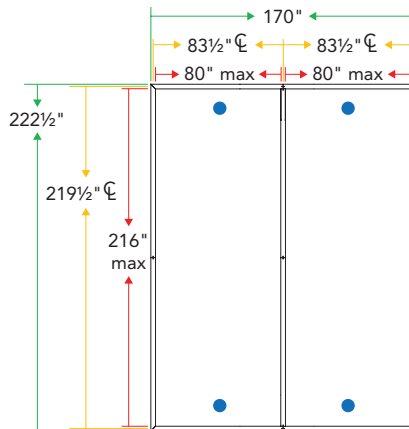

24. Standalone

1 Wood Slat Run and 1 Framed / Solid Panel Run between 2 Freeways

- If this module is standalone as shown:
 - Wood slat run and framed / solid run can be specified up to 144"W.
 - Freeways can be specified up to 216"W.
 - 120"H Max
- Wood Slat Planning: 48"W x 3 = 144"W
- If using solid panels or posts:
 - Worksurface – anywhere along run (solid panels only)
 - TV – anywhere along run (solid panels or posts)
 - Framed / Solid run can be replaced with drywall

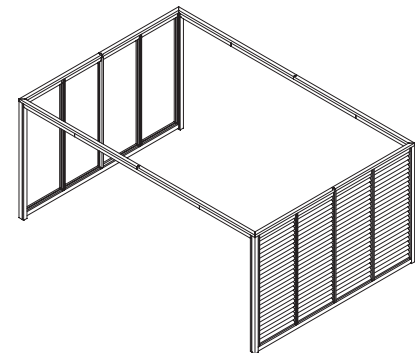
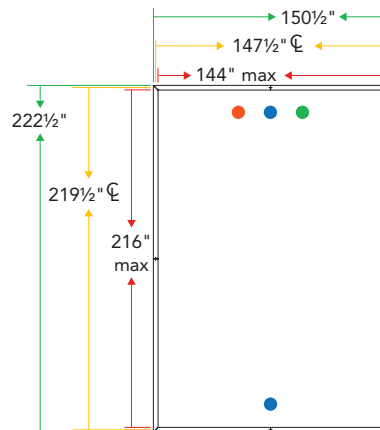

25. Connected

1 Wood Slat Run and 1 Framed / Solid Panel Run between 2 Freeways

- If this module is connected to other modules on any side:
 - Wood slat run and framed / solid run can be specified up to 80"W.
 - Freeways can be specified up to 216"W.
 - 120"H Max
- Wood Slat Planning: 42"W + 36"W = 78"W
- If using solid panels or posts:
 - Worksurface – anywhere along run (solid panels only)
 - TV – anywhere along run (solid panels or posts)
 - Framed / Solid run can be replaced with drywall

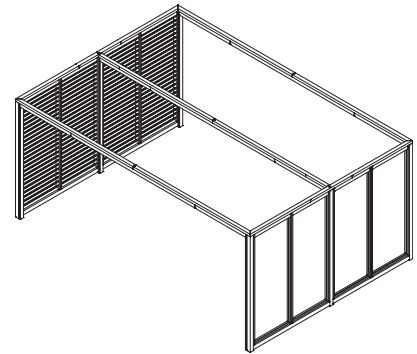
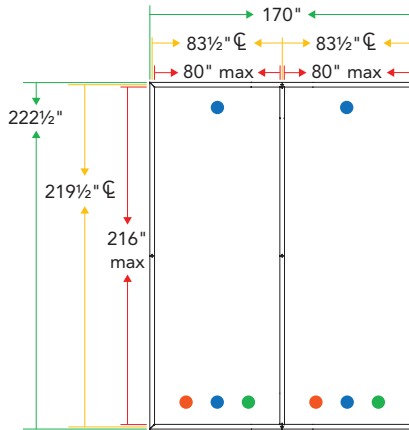

26. Standalone

1 Wood Slat Run with 3 Freeways

- If this module is standalone as shown:
 - Wood slat run and freeway opposite wood slats can be specified up to 144"W.
 - Freeways perpendicular to wood slats can be specified up to 216"W.
 - 120"H Max
- Wood Slat Planning: 48"W x 3 = 144"W
- If using inline posts:
 - TV – anywhere along run

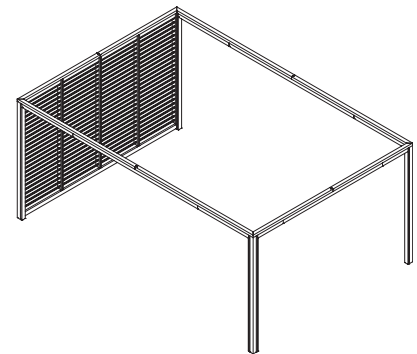
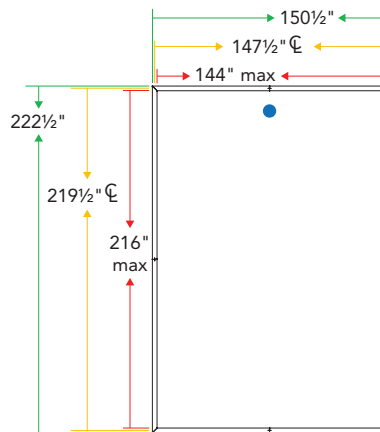

27. Connected

1 Wood Slat Run with 3 Freeways

- If this module is connected to other modules on any side:
 - Wood slat run and freeways opposite wood slats can be specified up to 80"W.
 - Freeways perpendicular to wood slats can be specified up to 216"W.
 - 120"H Max
- Wood Slat Planning: 42"W + 36"W = 78"W
- If using inline posts:
 - TV – anywhere along run

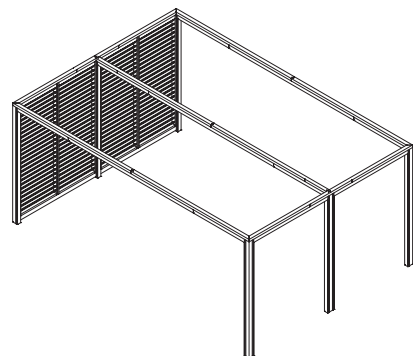
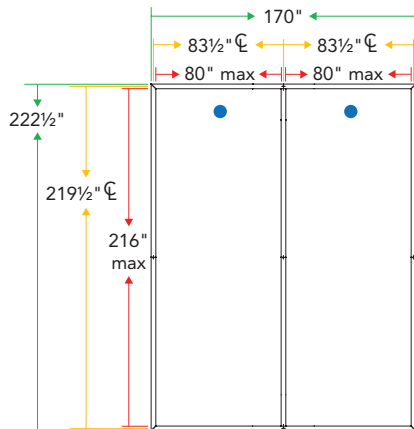

28. Standalone

2 Framed / Solid Panel Runs between 1 Wood Slat Run and 1 Freeway

- If this module is standalone as shown:
 - Wood slat run and freeway opposite wood slats can be specified up to 216"W.
 - Framed / solid panel runs can be specified up to 144"W.
- **Height limitation: 96"H Max**
- Wood Slat Planning: 36"W x 6 = 216"W
- If using solid panels or posts:
 - Worksurface – anywhere along run (solid panels only)
 - TV – anywhere along run (solid panels or posts)
 - Framed / Solid run can be replaced with drywall

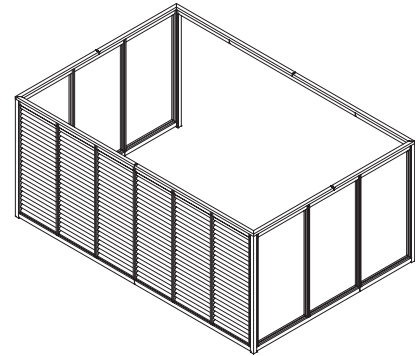
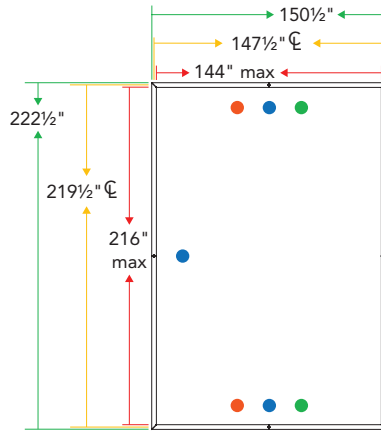

29. Connected

2 Framed / Solid Panel Runs between 1 Wood Slat Run and 1 Freeway

- If this module is connected to other modules on any side:
 - Wood slat run and freeway opposite wood slats can be specified up to 216"W.
 - Framed / solid panel runs can be specified up to 80"W.
- **Height limitation: 96"H Max**
- Wood Slat Planning: 36"W x 6 = 216"W
- If using solid panels or posts:
 - Worksurface – anywhere along run (solid panels only)
 - TV – anywhere along run (solid panels or posts)
 - Framed / Solid run can be replaced with drywall

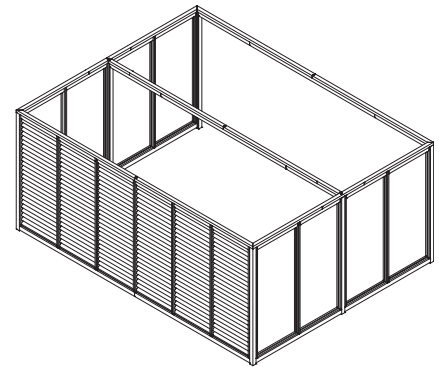
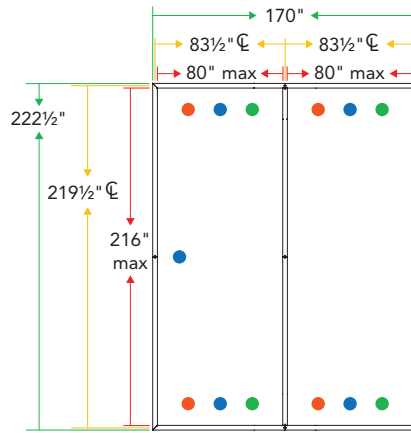

30. Standalone

L-Configured Framed / Solid Panel Run and Wood Slat Run with 2 Freeways

- If this module is standalone as shown:
 - Wood slat run and freeway opposite wood slats can be specified up to 216"W.
 - Framed / solid panel run and freeway opposite framed / solid run can be specified up to 144"W.
- **Height limitation: 96"H Max**
- Wood Slat Planning: 36"W x 6 = 216"W
- If using solid panels or posts:
 - Worksurface – anywhere along run (solid panels only)
 - TV – anywhere along run (solid panels or posts)
 - Framed / Solid run can be replaced with drywall

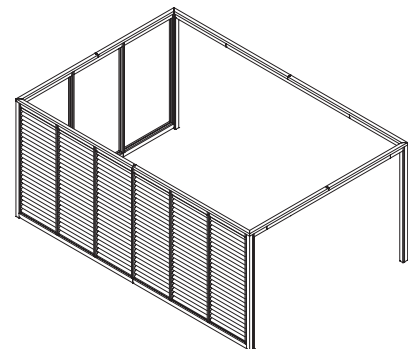
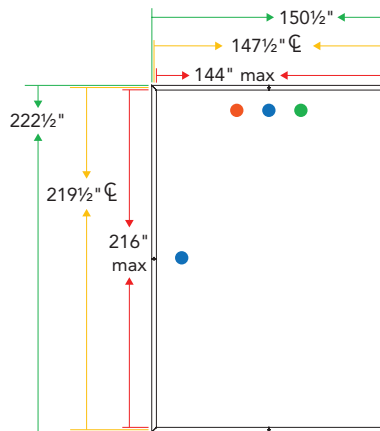

31. Connected

L-Configured Framed / Solid Panel Run and Wood Slat Run with 2 Freeways

- If this module is connected to other modules on any side:
 - Wood slat run and freeway opposite wood slats can be specified up to 216"W.
 - Framed / solid panel run and freeway opposite framed / solid run can be specified up to 80"W.
- **Height limitation: 96"H Max**
- Wood Slat Planning: 36"W x 6 = 216"W
- If using solid panels or posts:
 - Worksurface – anywhere along run (solid panels only)
 - TV – anywhere along run (solid panels or posts)
 - Framed / Solid run can be replaced with drywall

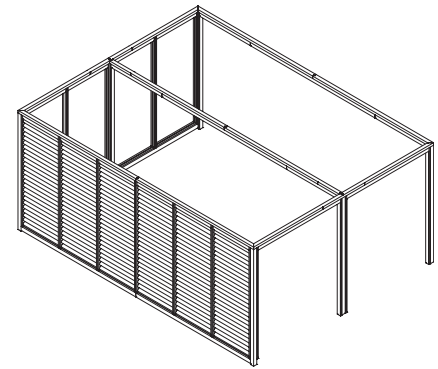
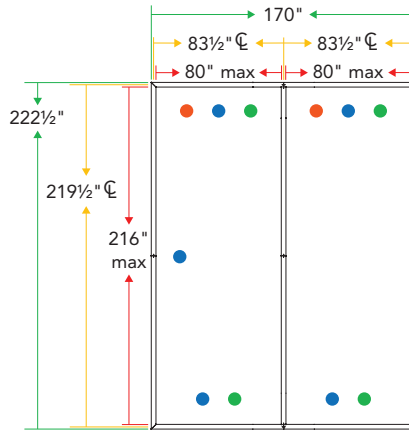

General Guidelines

- The following typicals consist of panels, freeways, or doors between 4 structural posts. They are labeled as modules. **All C-F modules must be anchored into the floor at posts and all panels must be anchored into the floor using standard seismic anchors.**
- **Framed glass and/or solid panels with an integrated glass clerestory must be 3/8" laminated glass when freestanding in SDC C-F.**
- Maximum height varies between 96"H - 120"H.
- Minimum height is 86" due to clearance needed for freeways and doors to meet 80"H clear opening.
- Panel runs are limited to 24"W minimum – (27.5" CL TO CL) for four-sided modules.
- All modules can connect at structural posts in any direction.
- ALL DIMENSIONS ARE LENGTH MAXIMUMS UNLESS OTHERWISE NOTED.
- If Worksurface Mounting, worksurfaces must be ≤ 135lbs self weight at 42" AFF (60" x 72" worksurface max).
- If TV Mounting, TVs must be ≤ 60lbs at ≤ 78" AFF, ≤ 6" CG from Panel Surface, no pivot or articulating / extending arm allowed. 1 TV allowed per module. If you have multiple modules connected, TVs are allowed to be back to back.
- **Only a framed/solid run can be replaced with drywall. Reference the orange dots in the modules.**
 - If drywall is acting as one of the 4 walls of a module, the perpendicular walls coming off the drywall should follow the rules of a framed/solid run. Find the correct module that applies with those walls as framed/solid runs.
 - A post to post freeway or wood slat run perpendicular to drywall should follow the rules of a framed/solid run.

SDC C-F: Freestanding Panel Module Possibilities

32. Standalone - 2 Framed / Solid Panel Runs between 2 Freeways
33. Connected - 2 Framed / Solid Panel Runs between 2 Freeways
34. Standalone - 1 Framed / Solid Panel Run with 3 Freeways
35. Connected - 1 Framed / Solid Panel Run with 3 Freeways
36. Standalone - L-Configured Framed / Solid Panel Runs with 2 Freeways
37. Connected - L-Configured Framed / Solid Panel Runs with 2 Freeways
38. Standalone - 4 Freeways
39. Connected - 4 Freeways
40. Standalone - 3 Framed / Solid Panel Runs with 1 Freeway, Single Door
41. Connected - 3 Framed / Solid Panel Runs with 1 Freeway, Single Door
42. Standalone - 3 Framed / Solid Panel Runs with 1 Freeway, 48"W Door
43. Connected - 3 Framed / Solid Panel Runs with 1 Freeway, 48"W Door
44. Standalone - 3 Framed / Solid Panel Runs with 1 Freeway, Freeway over 42"W
45. Connected - 3 Framed / Solid Panel Runs with 1 Freeway, Freeway over 42"W
46. Standalone - 4 Framed / Solid Panel Runs and Phone booth, Single Door
47. Connected - 4 Framed / Solid Panel Runs and Phone booth, Single Door
48. Standalone - 4 Framed / Solid Panel Runs and Phone booth, Double Door & 48"W Door
49. Standalone - 4 Framed / Solid Panel Runs and Phone booth, Freeway over 42"W
50. Standalone - 1 Framed / Solid Panel Run between Building Structure

32. Standalone

2 Framed / Solid Panel Runs between 2 Freeways

- If this module is standalone as shown:
 - Panels can be specified up to 60"W.
 - Freeways can be specified up to 216"W.
- If using solid panels or posts:
 - TV – anywhere along run. **If a TV is added, freeway run is limited to 156"W**
 - Framed / Solid run can be replaced with drywall

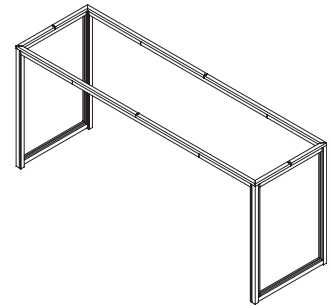
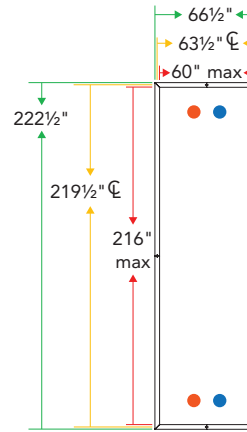

33. Connected

2 Framed / Solid Panel Runs between 2 Freeways

- If this module is connected to other modules on any side:
 - The framed / solid panels are limited to 36"W maximum.
 - Freeways can be specified up to 216"W.
- If using solid panels or posts:
 - TV – anywhere along run. **If a TV is added, freeway run is limited to 156"W**
 - Framed / Solid run can be replaced with drywall

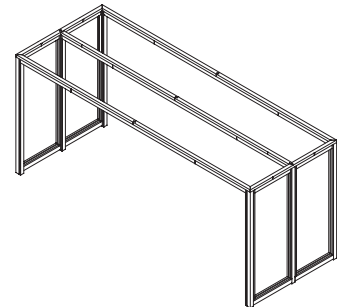
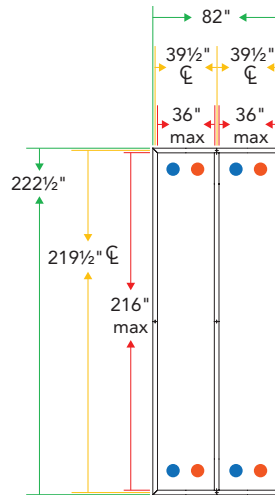

34. Standalone

1 Framed / Solid Panel Run with 3 Freeways

- If this module is standalone as shown:
 - Panels can be specified up to 60"W.
 - Freeway opposite panels can be specified up to 60"W.
 - Freeways perpendicular to panels can be specified up to 144"W.
- If using solid panels or posts:
 - Worksurface – anywhere along run (solid panels only)
 - TV – anywhere along run (solid panels or posts)
 - Framed / Solid run can be replaced with drywall

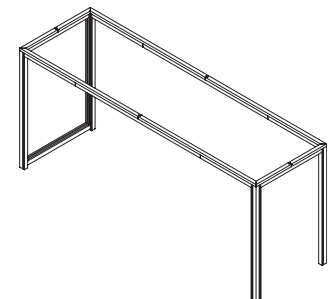
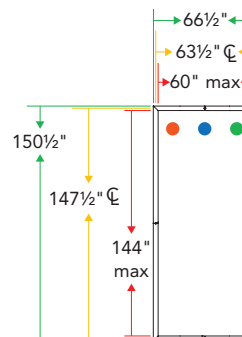

35. Connected

1 Framed / Solid Panel Run with 3 Freeways

- If this module is connected to other modules on any side:
 - The framed / solid panels are limited to 36"W maximum.
 - Freeways opposite to panels can be specified up to 36"W.
 - Freeways perpendicular to panels can be specified up to 144"W.
- If using solid panels or posts:
 - Worksurface – anywhere along run (solid panels only)
 - TV – anywhere along run (solid panels or posts)
 - Framed / Solid run can be replaced with drywall

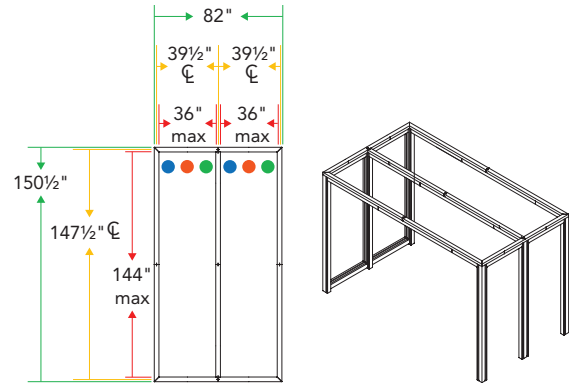

36. Standalone

L-Configured Framed / Solid Panel Runs with 2 Freeways

- If this module is standalone as shown:
 - One run of panels can be specified up to 72"W connected to second run of panels with 2-way post.
 - Second run of panels can be specified up to 120"W.
 - Freeways can be specified up to 72"W and 120"W opposite coordinating panel runs.
- No worksurface or TV mounting allowed.
 - Framed / Solid run can be replaced with drywall

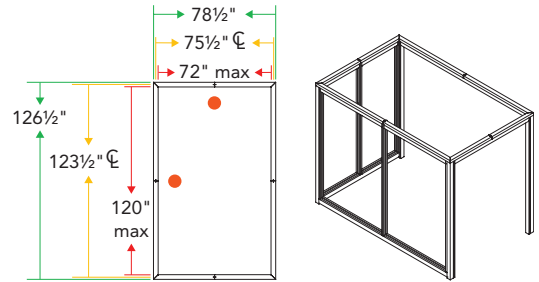

37. Connected

L-Configured Framed / Solid Panel Runs with 2 Freeways

- If this module is connected to other modules on any side:
 - One run of panels can be specified up to 72"W connected to second run of panels with 2-way post.
 - Second run of panels can be specified up to 120"W.
 - Freeways can be specified up to 72"W and 120"W opposite coordinating panel runs.
- No worksurface or TV mounting allowed.
 - Framed / Solid run can be replaced with drywall

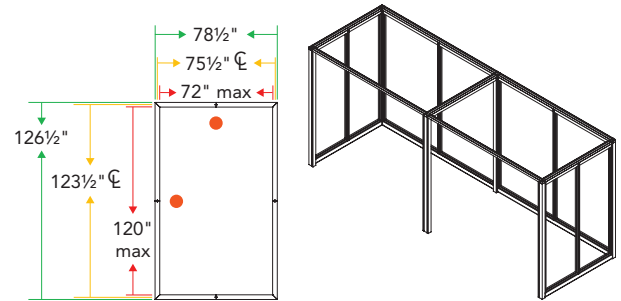

38. Standalone

4 Freeways

- If this module is standalone as shown:
 - Freeways can be specified up to 126"W.
- No worksurface or TV mounting allowed.

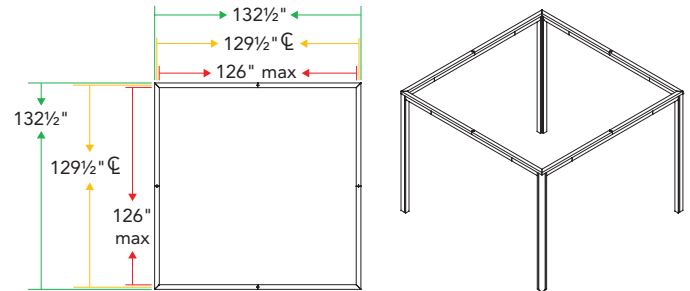

39. Connected

4 Freeways

- If this module is connected to other modules on any side:
 - Freeways can be specified up to 126"W.
- No worksurface or TV mounting allowed.

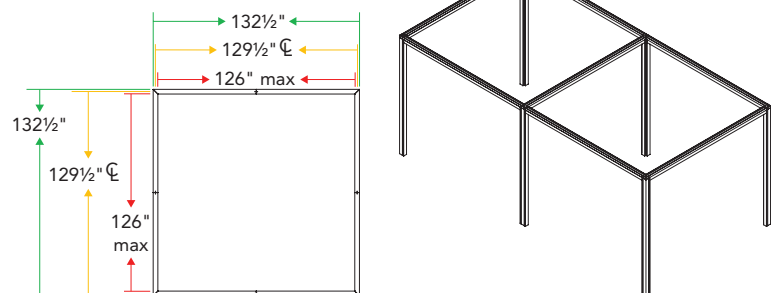

40. Standalone

3 Framed / Solid Panel Runs with 1 Freeway – SINGLE DOOR

- If this module is standalone as shown:
 - Panel run with door can be specified up to 162"W.
 - Panel runs perpendicular to door can be specified up to 72"W.
 - Freeway can be specified up to 162"W.
 - Single door or freeway up to 42"W can be added to 162" max panel run.
 - Must have minimum 9"W wing panel adjacent to post on one side within run with door.
 - **Height Limitation: 96"H Maximum**
- If using solid panels or posts:
 - Worksurface – anywhere along run (solid only)
 - TV – anywhere along run
 - Overhead – mount anywhere along run (solid only)
 - Framed / Solid run can be replaced with drywall

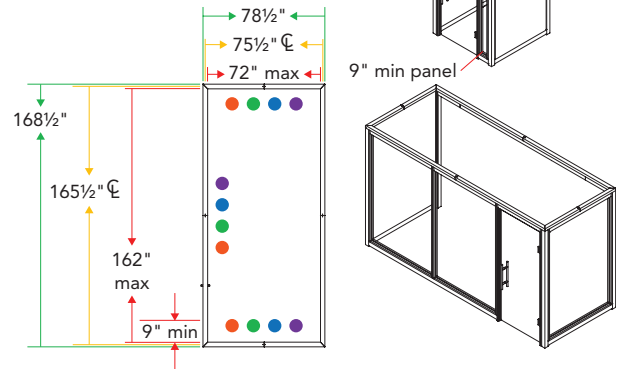

41. Connected

3 Framed / Solid Panel Runs with 1 Freeway – SINGLE DOOR

- If this module is connected to other modules on any side:
 - Panel run with door can be specified up to 162"W.
 - Panel runs perpendicular to door can be specified up to 60"W.
 - Freeway can be specified up to 162"W.
 - Single door or freeway up to 42"W can be added to 162" max panel run.
 - Must have minimum 9"W wing panel adjacent to post on one side within run with door.
 - **Height Limitation: 96"H Maximum**
- If using solid panels or posts:
 - Worksurface – anywhere along run (solid only)
 - TV – anywhere along run
 - Overhead – mount anywhere along run (solid only)
 - Framed / Solid run can be replaced with drywall

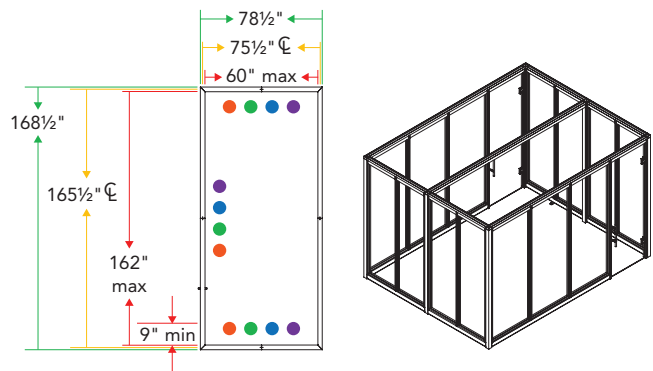

42. Standalone

3 Framed / Solid Panel Runs with 1 Freeway – 48"W DOOR

- If this module is standalone as shown:
 - Panel run with door can be specified up to 162"W.
 - Panel runs perpendicular to door can be specified up to 72"W.
 - Freeway can be specified up to 162"W.
 - A 48"W door can be added to 162" max panel run.
 - Must have 54"W framed / solid wing wall at 1 post and additional 54"W framed / solid minimum wall within run with door.
 - **Height Limitation: 96"H Maximum**
- No worksurface, overhead or TV mounting allowed.
 - Framed / Solid run can be replaced with drywall

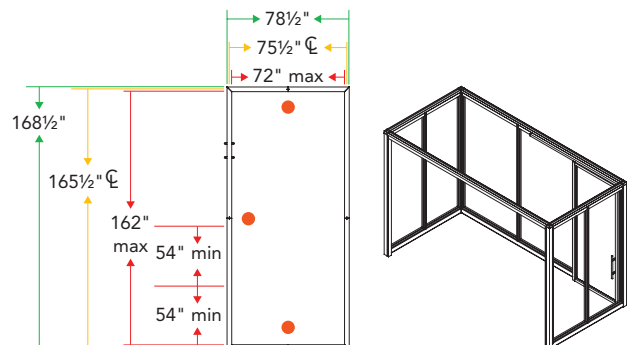

43. Connected

3 Framed / Solid Panel Runs with 1 Freeway – 48"W DOOR

- If this module is connected to other modules on any side:
 - Panel run with door can be specified up to 162"W.
 - Panel runs perpendicular to door can be specified up to 60"W.
 - Freeway can be specified up to 162"W.
 - A 48"W door can be added to 162" max panel run.
 - Must have 544"W framed / solid wing wall at 1 post and additional 54"W framed / solid minimum wall within run.
 - **Height Limitation: 96"H Maximum**
- No worksurface, overhead or TV mounting allowed.
 - Framed / Solid run can be replaced with drywall

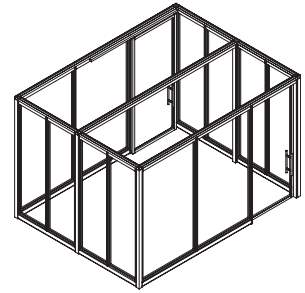
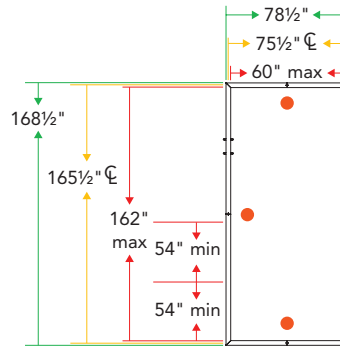

44. Standalone

3 Framed / Solid Panel Runs with 1 Freeway – FREEWAY over 42"W

- If this module is standalone as shown:
 - Panel run with freeway and wing panel can be specified up to 162"W.
 - Panel runs perpendicular to freeway with wing panel can be specified up to 72"W.
 - Post to post freeway can be specified up to 162"W.
 - Freeway with wing panel can only be added to 162" max panel run. Must have 54"W framed / solid wing wall at 1 post and additional 54"W framed / solid minimum wall within run.
 - **Height Limitation: 96"H Maximum**
- No worksurface, overhead or TV mounting allowed.
 - Framed / Solid run can be replaced with drywall

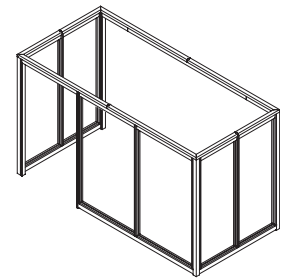
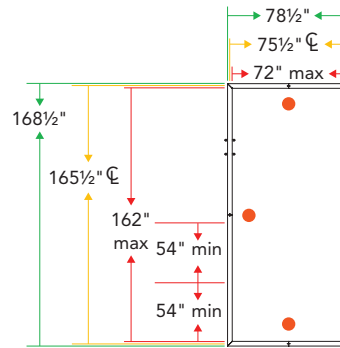

45. Connected

3 Framed / Solid Panel Runs with 1 Freeway – FREEWAY over 42"W

- If this module is connected to other modules on any side:
 - Panel run with freeway and wing panel can be specified up to 162"W.
 - Panel runs perpendicular to freeway with wing panel can be specified up to 60"W.
 - Post to post freeway can be specified up to 162"W.
 - Freeway with wing panel can only be added to 162" max panel run. Must have 54"W framed / solid wing wall at 1 post and additional 54"W framed / solid minimum wall within run.
 - **Height Limitation: 96"H Maximum**
- No worksurface, overhead or TV mounting allowed.
 - Framed / Solid run can be replaced with drywall

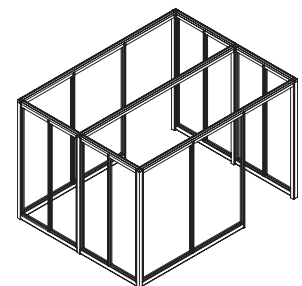
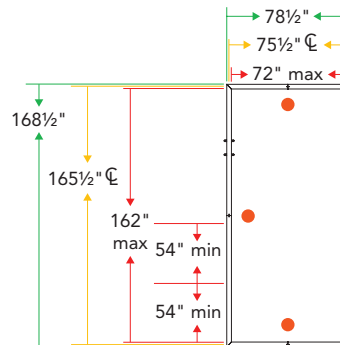

46. Standalone

4 Framed / Solid Panel Runs
– SINGLE DOOR

- If this module is standalone as shown:

- Panel runs can be specified up to 192" W.
- Single door or freeway up to 42" W can be added to any panel run.
- Must have minimum 9" W wing panel adjacent to post on one side within run with door.
- 1 door allowed per module.

- If using solid panels or posts:

- Worksurface – anywhere along run (solid only)
- TV – anywhere along run
- Overhead – mount anywhere along run (solid only)
- Framed / Solid run can be replaced with drywall

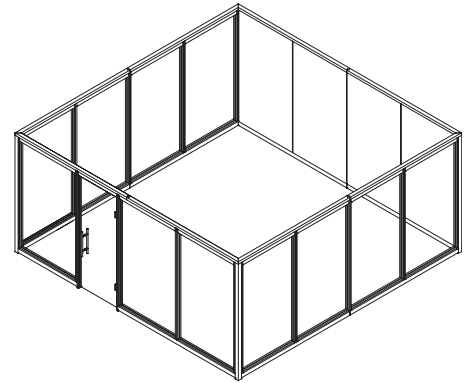
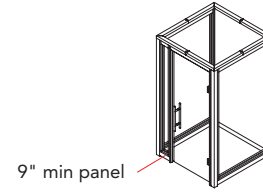
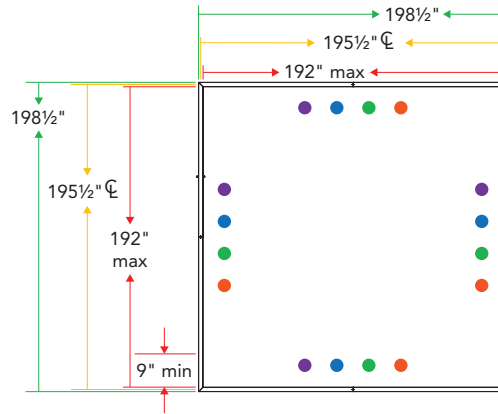

47. Connected

4 Framed / Solid Panel Runs – SINGLE DOOR

- If this module is connected to other modules on any side:
 - Panel runs can be specified up to 144" W.
 - Single door or freeway up to 42" W can be added to any panel run.
 - Must have minimum 9" W wing panel adjacent to post on one side within run with door.
 - 1 door allowed per module.

- If using solid panels or posts:

- Worksurface – anywhere along run (solid only): 96"H
- TV – anywhere along run
- Overhead – mount anywhere along run (solid only): 108"H
- Framed / Solid run can be replaced with drywall: 96"H

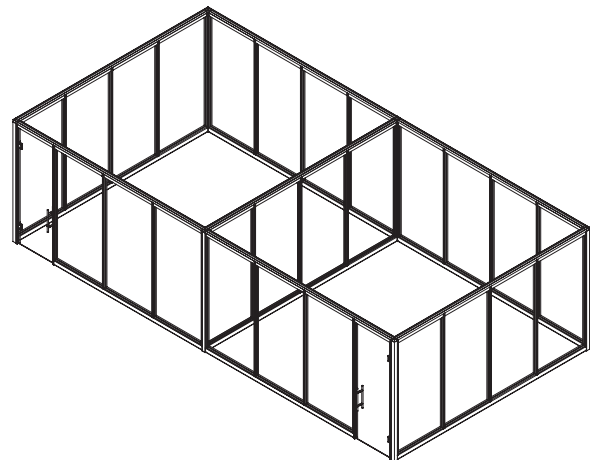
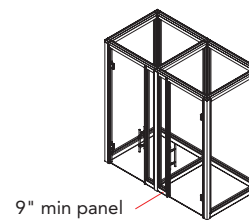
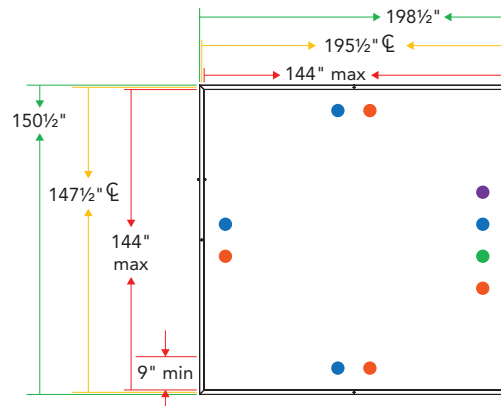

Panels & Trim

Beyond® — Working with Freestanding: SDC C-F

48. Standalone

4 Framed / Solid Panel
Runs – DOUBLE DOOR OR
48"W DOOR

- If this module is standalone as shown:
 - Panel runs can be specified up to 192"W.
 - A double door or 48"W door can be added to any panel run.
 - Must have 54"W framed / solid wing wall at 1 post and additional 54"W framed / solid minimum wall within run with door.
 - 1 door allowed per module.
- No worksurface, overhead or TV mounting allowed.
 - Framed / Solid run can be replaced with drywall

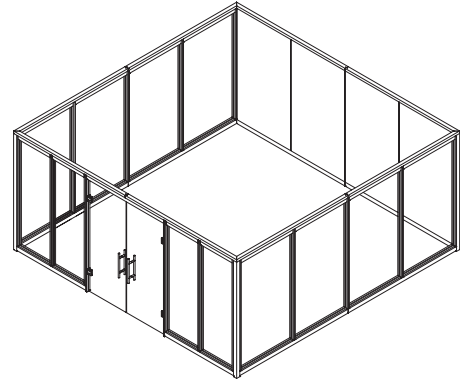
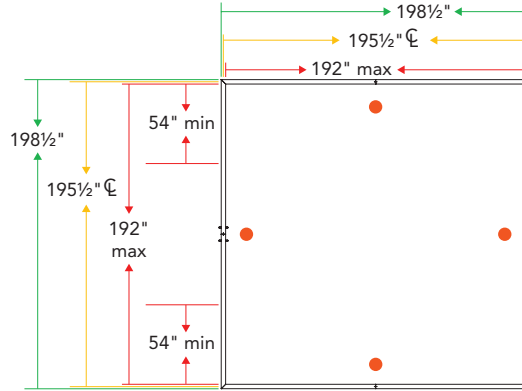

49. Standalone

4 Framed / Solid Panel
Runs – FREEWAY over
42"W

- If this module is standalone as shown:
 - Panel runs can be specified up to 192"W.
 - A freeway over 42"W can be added to any panel run.
 - Must have 54"W framed / solid wing wall at 1 post and additional 54"W framed / solid minimum wall within run with freeway.
 - 1 freeway allowed per module.
- No worksurface, overhead or TV mounting allowed.
 - Framed / Solid run can be replaced with drywall

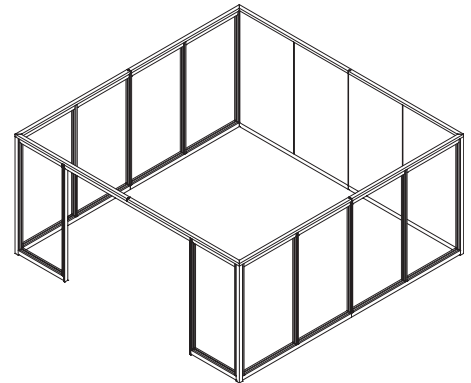
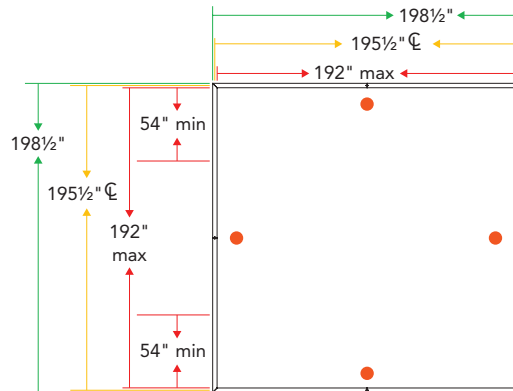

50. Standalone

1 Framed / Solid Panel Run between Building
Structure

- Any size door or freeway can be added anywhere within the run.
- 216"W freeway is possible if desired.
- 1 door or freeway allowed per module.
- No worksurface or TV mounting allowed.

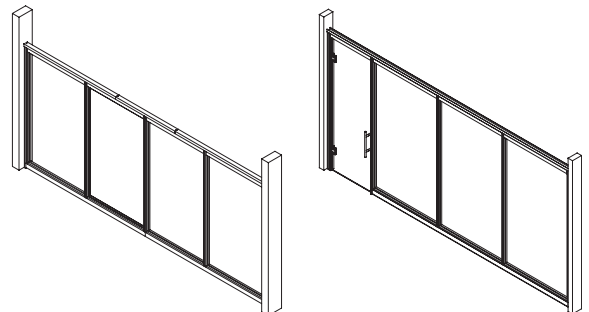
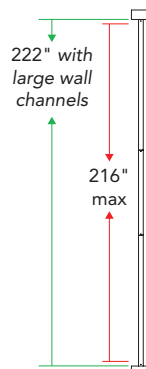

General Guidelines

- The following typicals consist of panels, freeways, doors and wood slat panels between 4 structural posts. They are labeled as modules. **All C-F modules must be anchored into the floor at posts and all panels must be anchored into the floor using standard seismic anchors.**
- **Framed glass MUST be 3/8" laminated in SDC C-F.**
- **Maximum height is 96"H.**
- Minimum height is 86"H due to clearance needed for freeways and doors to meet 80"H clear opening.
- Panel runs are limited to 24"W minimum – (27.5" CL TO CL) for four-sided modules.
- All modules can connect at structural posts in any direction.
- ALL DIMENSIONS ARE LENGTH MAXIMUMS UNLESS OTHERWISE NOTED.
- If Worksurface Mounting, worksurfaces must be ≤ 135lbs self weight at 42" AFF (60" x 72" worksurface max).
- If TV Mounting, TVs must be ≤ 60lbs at ≤ 78" AFF, ≤ 6" CG from Panel Surface, no pivot or articulating / extending arm allowed. 1 TV allowed per module. If you have multiple modules connected, TVs are allowed to be back to back.
- Wood slat panel standard special sizes reminder:
 - Widths: 24"W, 30"W, 36"W, 42"W, 48"W
 - Heights: 96"H, 102"H, 108"H, 112"H, 120"H
- Applications with wood slat runs connecting at a 2-way post will always require site specific calculations. These applications are not covered in Allsteel's blanket calculations.
- **Only a framed/solid run can be replaced with drywall. Reference the orange dots in the modules.**
 - If drywall is acting as one of the 4 walls of a module, the perpendicular walls coming off the drywall should follow the rules of a framed/solid run. Find the correct module that applies with those walls as framed/solid runs.
 - A post to post freeway or wood slat run perpendicular to drywall should follow the rules of a framed/solid run.

SDC C-F: Freestanding Panel Module Possibilities

51. Standalone - 2 Wood Slat Runs between 2 Freeways
52. Connected - 2 Wood Slat Runs between 2 Freeways
53. Standalone - 1 Wood Slat Run with 3 Freeways
54. Connected - 1 Wood Slat Run with 3 Freeways
55. Connected - 2 Framed / Solid Panel Runs between 1 Wood Slat Run and 1 Freeway

51. Standalone

2 Wood Slat Runs between 2 Freeways

- If this module is standalone as shown:
 - Wood slat runs can be specified up to 60"W.
 - Freeways can be specified up to 132"W.
- Wood Slat Planning: 30"W x 2 = 60"W or 24"W + 36"W = 60"W
- No TV mounting possible.
- **Height Limitation: 96"H Maximum**

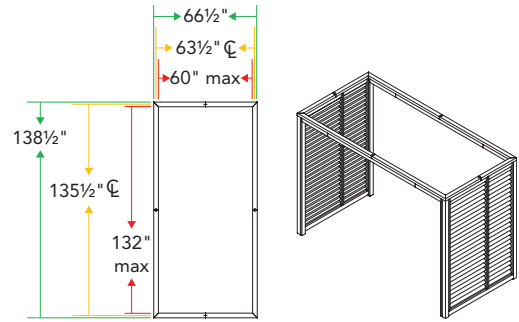

52. Connected

2 Wood Slat Runs between 2 Freeways

- If this module is connected to other modules on any side:
 - Wood slat runs can be specified up to 60"W.
 - Freeways can be specified up to 132"W.
- Wood Slat Planning: 30"W x 2 = 60"W or 24"W + 36"W = 60"W
- No TV mounting possible.
- **Height Limitation: 96"H Maximum**

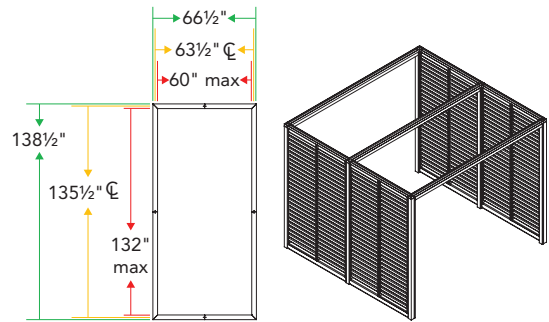

53. Standalone

1 Wood Slat Run with 3 Freeways

- If this module is standalone as shown:
 - Wood slat run and freeway opposite wood slats can be specified up to 60"W.
 - Freeways perpendicular to wood slats can be specified up to 132"W.
- Wood Slat Planning: 30"W x 2 = 60"W or 24"W + 36"W = 60"W
- No TV mounting possible.
- **Height Limitation: 96"H Maximum**

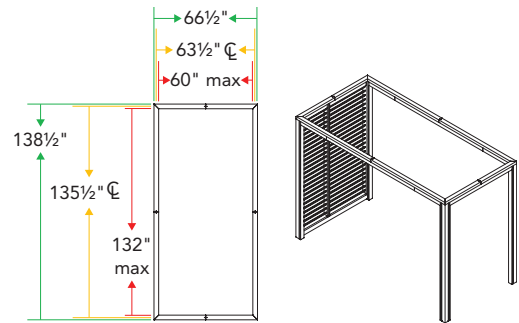

54. Connected

1 Wood Slat Run with 3 Freeways

- If this module is connected to other modules on any side:
 - Wood slat run and freeways opposite wood slats can be specified up to 36"W.
 - Freeways perpendicular to wood slats can be specified up to 132"W.
- Wood Slat Planning: 36"W wood slat panels to be used.
- No TV mounting possible.
- **Height Limitation: 96"H Maximum**

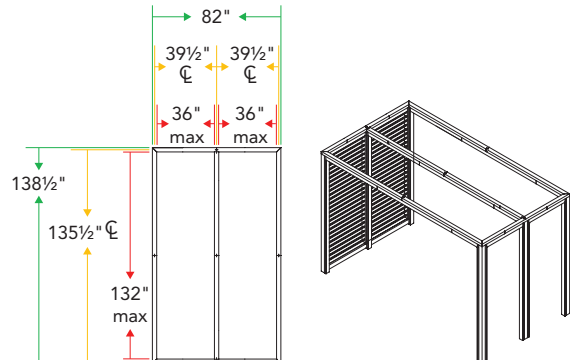

55. Connected

2 Framed / Solid Panel Runs between 1 Wood Slat Run and 1 Freeway

- No standalone option for this module.
- Must specify at least 2 connected modules as shown:
 - No modules can be connected to wood slat run.
 - Wood slat run and freeway opposite wood slats can be specified up to **99.5"W**. Required minimum being 48"W.
 - Framed / solid panel runs can be specified up to 60"W.
 - Required to use 24"W wood slat panels.
- **Height limitation: 96"H Max**
- Wood Slat Planning: 24"W x 4 = 96"W + 3.5" inline post = 99.5"
 - TV – anywhere along run
 - Framed / Solid run can be replaced with drywall

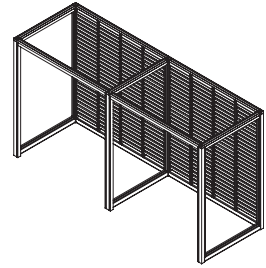
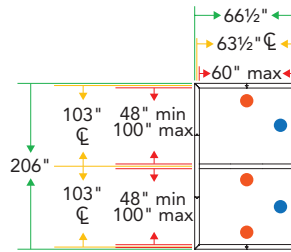

Suspended ceiling can be added to freestanding Beyond. Most components, including the suspended ceiling, are supplied by others. Allsteel provides the following components:

- Freestanding cornice - provides the structure to tie the Beyond walls together. See page 80 for specification details.
- Suspended Ceiling Mounting Brackets - brackets to support Unistrut® cross beams, attached to the cornice. QTY (2) brackets are required at every vertical seam in the ceiling trim.
- Flush mounted ceiling trim for flush ceiling applications. See page 166 for specification details.
- Suspended Ceiling Mount Brackets.
 - Qty 1 model consists of two bracket assemblies, which mount 1 Unistrut.
 - New brackets are NOT backwards compatible. Physically taller than the de-emphasized bracket to lift Unistrut the same distance as the cornice increased in height.
 - Older Unistrut mount bracket to be de-emphasized.

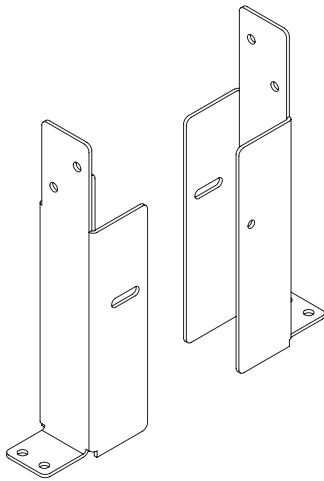

Mounting Brackets

The ceiling structure hangs from the Unistrut cross beam supports (not provided by Allsteel). The maximum freestanding span in one direction with suspended ceiling is 12' 3/2".

The maximum distance between each Unistrut cross beam is 4 feet, as illustrated below.

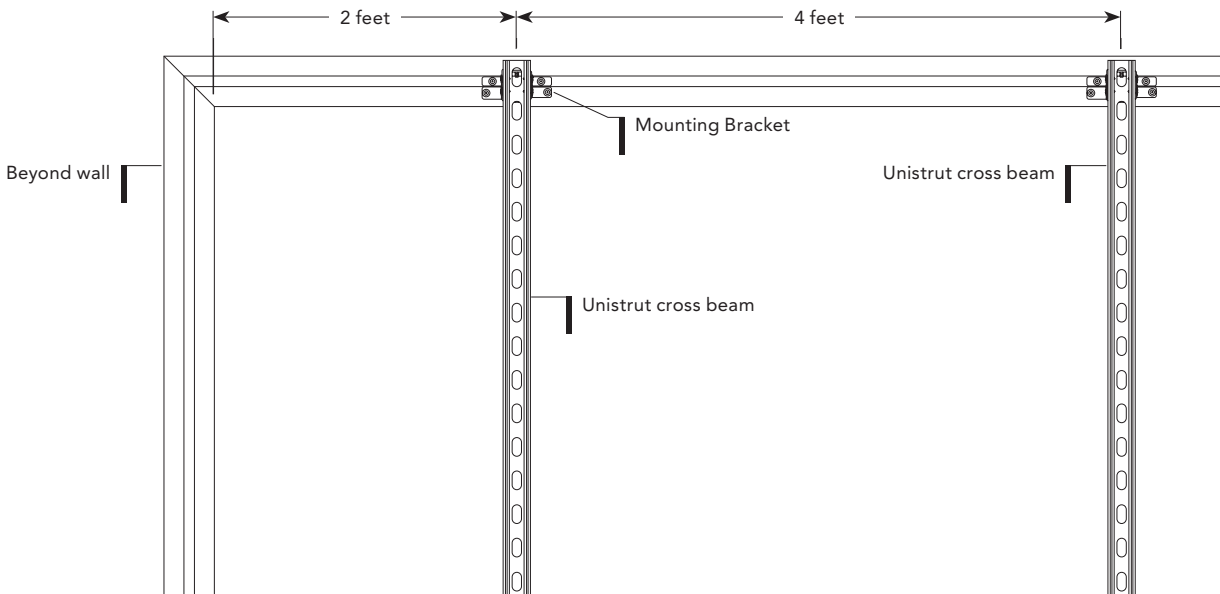

- Review charts for required Unistrut® type per desired spacing, and per ceiling weight pounds per square foot.

- The charts below indicate the required Unistrut® crossbeam type per the desired spacing, and per ceiling weight pounds per square foot.

lbs./FT ²	Span (FT) Support Every 4 ft			Support every 4 ft
	8	10	12	
1.00	P2000T	P2000	P1000-S	Support every 4 ft
1.25	P2000T	P1000T	P5500T	
1.50	P2000T	P1000T-S	P5500T	
1.75	P2000	P1000-S	P5500T	
2.00	P1100	P5500T	P5500T	
2.25	P1100	P5500T	P5500	
2.50	P1000	P5500T	P1001T	

lbs./FT ²	Span (FT) Support Every 3 ft			Support every 3 ft
	8	10	12	
1.00	P2000T	P2000T	P1000	Support every 3 ft
1.25	P2000T	P2000	P1000T-S	
1.50	P2000T	P1100	P5500T	
1.75	P2000T	P1000	P5500T	
2.00	P2000T	P1000T-S	P5500T	
2.25	P2000	P1000-S	P5500T	
2.50	P2000	P1000-S	P5500T	

Ceiling Channel Support	Height	Width	Gauge	Single/Double	Perforations
P5000	3¼"	1⅝"	12	Single	No
P5000T	3¼"	1⅝"	12	Single	Yes
P1001	3¼"	1⅝"	12	Double	No
P1001T	3¼"	1⅝"	12	Double	Yes
P5500	2⅞"	1⅝"	12	Double	No
P5500T	2⅞"	1⅝"	12	Double	Yes
P1000-Side	1⅝"	1⅝"	12	Single	No
P1000T-Side	1⅝"	1⅝"	12	Single	Yes

Ceiling Channel Support	Height	Width	Gauge	Single/Double	Perforations
P1000	1⅝"	1⅝"	12	Single	No
P1000T	1⅝"	1⅝"	12	Single	Yes
P1100	1⅝"	1⅝"	14	Single	No
P1100T	1⅝"	1⅝"	14	Single	Yes
P2000	1⅝"	1⅝"	16	Single	No
P2000T	1⅝"	1⅝"	16	Single	Yes

- There are some additional guidelines regarding the Unistrut® crossbeam. The Unistrut must either be:
 - perpendicular to the main suspended ceiling rail,
 - or perpendicular to the grid support (strongback), if applicable.
- See below for ceiling support assembly examples with lighting clearance:
 - Standard Grid
 - Distance between the bottom of the Unistrut® support and the face of the ceiling grid = 5½".
 - B = Height of the suspended ceiling grid.
 - C = Clearance for the height of the ceiling light assembly.
 - 5½" – B = C
 - If light fixture height is > C but < 5½", mount the lighting fixture parallel to the Unistrut®, or plan for a more difficult assembly (cross rails put in after the light has been installed).
 - If light fixture height is > 5½", mount the lighting fixture parallel to the Unistrut®.
 - Grid with Support
 - Distance between the bottom of the Unistrut® support and the face of the ceiling grid = 5½".
 - D = Height of the suspended ceiling grid and grid support.
 - E = Clearance for the height of the ceiling light assembly.
 - 5½" – D = E
 - If light fixture height is > E but < 5½", mount the lighting fixture parallel to the Unistrut®, or plan for a more difficult assembly (cross rails put in after the light has been installed).
 - If light fixture height is > 5½", mount the lighting fixture parallel to the Unistrut®.

* If C or E are greater than the height of the light fixture, then the light can be positioned in any orientation without interference.

There are two main types of suspended ceilings that hang from the Unistrut support structure. The first type is flush mount, where the ceiling trim aligns flush with the Beyond panels; and the second type is overhang mount, which can overhang the Beyond panels up to 10 inches. The two options are detailed below and on the following page.

- Flush Mount Trim Option

- Supplied by Allsteel:

- Flush mount ceiling trim. Trim is 7" high and comes in 120" lengths.
- Mounting brackets to support Unistrut crossbeams. See page 166 for specification details.
- Freestanding cornice. See page 165 for specification details.

- Supplied by others:

- Ceiling trim brackets
- Ceiling grid connector clips
- Unistrut® crossbeams
- Suspended ceiling wire
- Ceiling tiles
- Ceiling grid

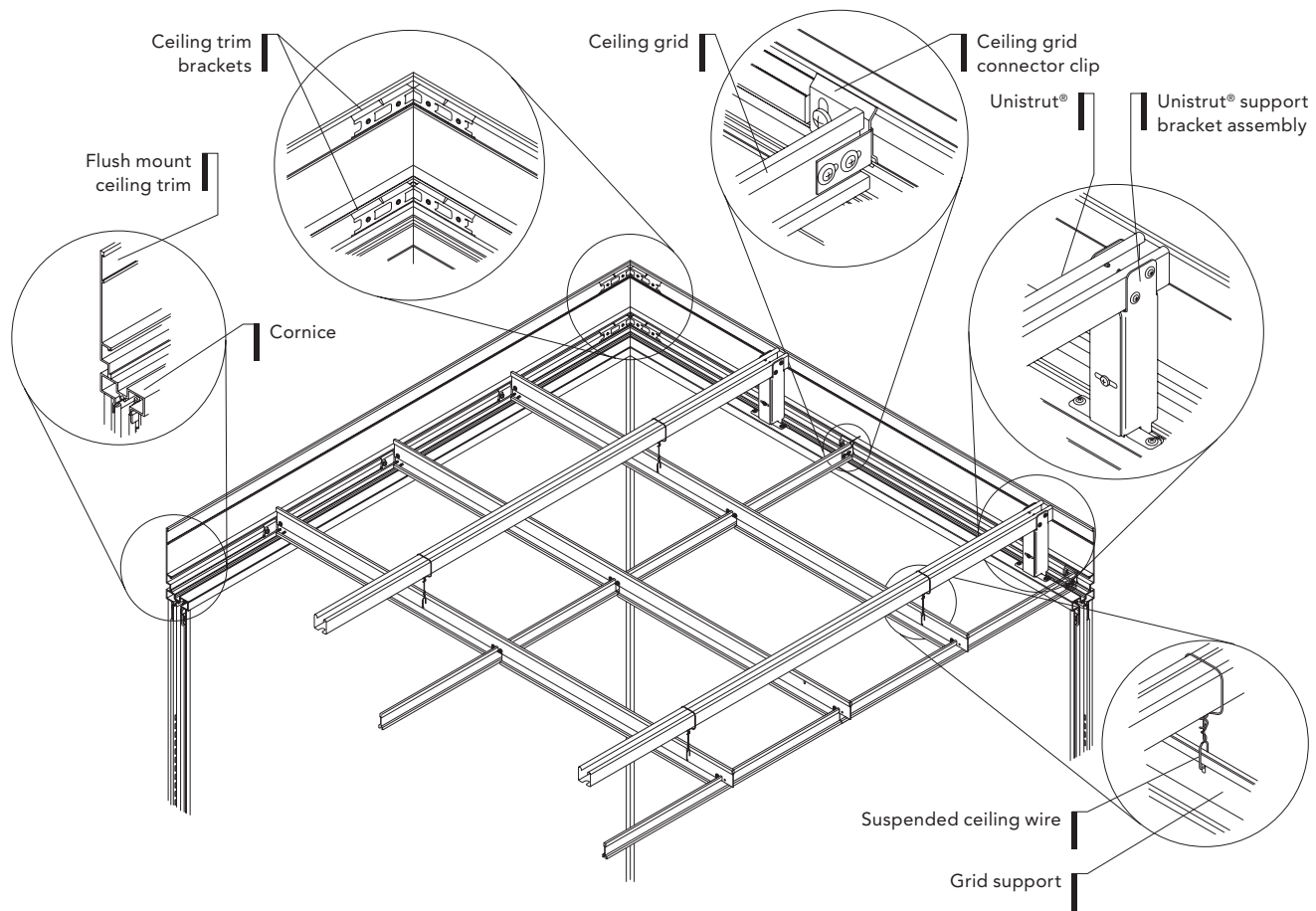

- Overhang Trim Option
 - Maximum overhang is 10". Note - Allsteel does not provide ceiling trim with the overhang option.
 - Supplied by Allsteel:
 - Mounting brackets to support Unistrut crossbeams. See page 166 for specification details.
 - Freestanding cornice. See page 165 for specification details.
 - Supplied by others:
 - Ceiling trim
 - Ceiling trim brackets
 - Ceiling grid
 - Ceiling grid connector clips
 - Unistrut® crossbeams
 - Suspended ceiling wire
 - Ceiling tiles

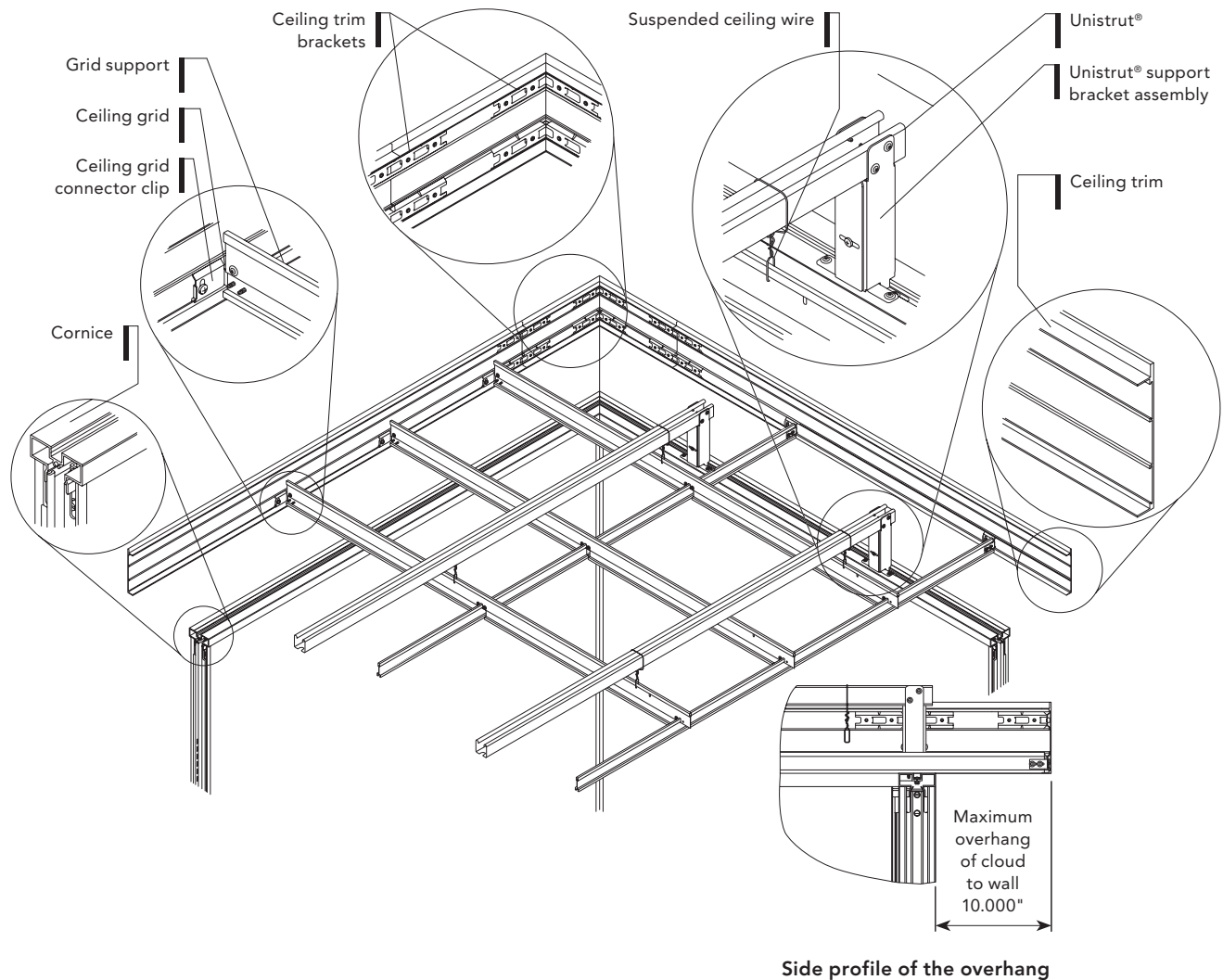

Panels & Trim

Determine ceiling type Beyond is to be installed underneath.

Through Drywall Ceiling into Ceiling Stud

No additional mounting components required

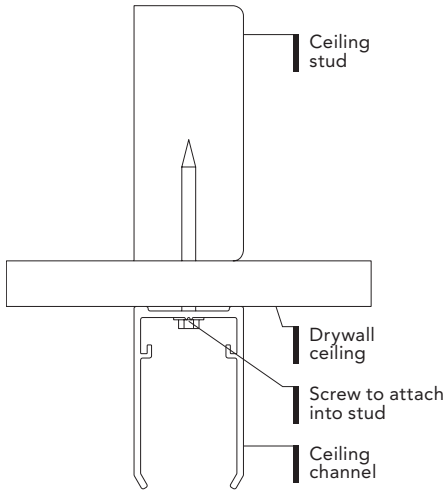

Under Ceiling Grid

Determine Grid Type

Additional mounting components required

Interlude® 1/16" Tee

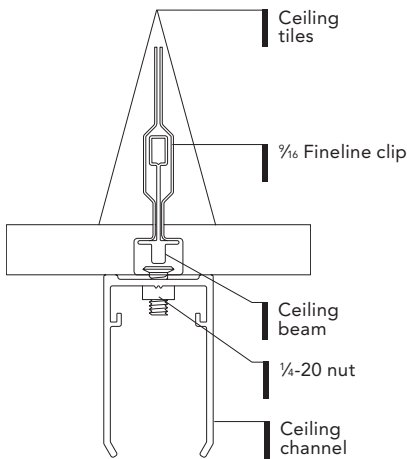

1/8" Reveal - 1/16" Slotted Tee

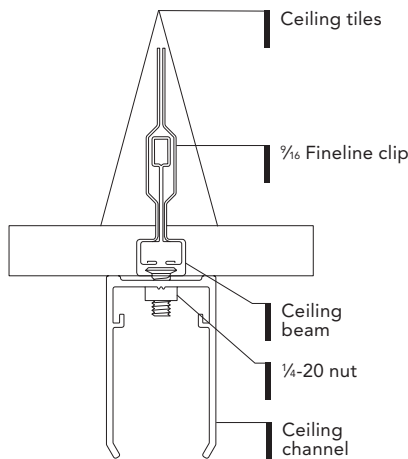

1/4" Reveal - 1/16" Slotted Tee

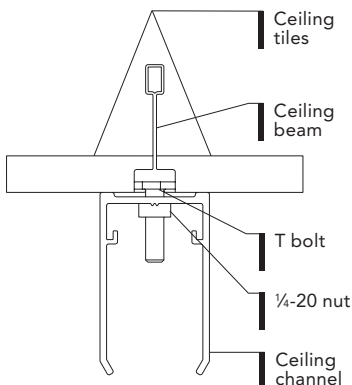

1/16" T Beam

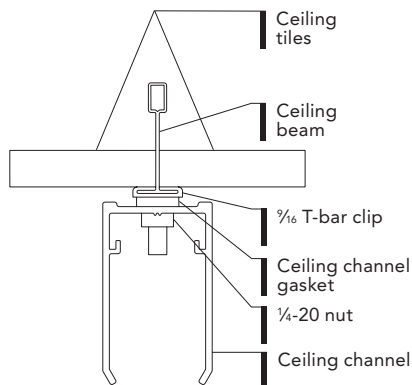

15/16" T Beam

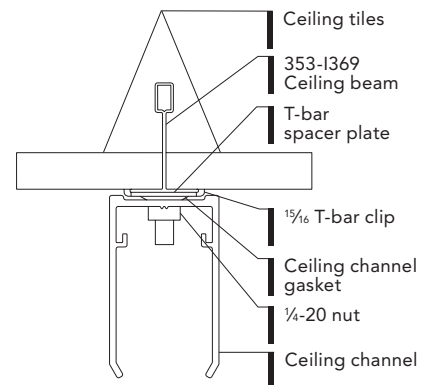

Ceiling Grid Mounting Clips

- Ceiling grid mounting clips are required to install Beyond under ceiling grid. Clips attach ceiling channel to grid. Multiple clip types are available to fit the most common grid types. Mounting clips are non-defacing.
- National, state and/or local codes will dictate proper connection methods based on building conditions and location. Please consult with the local building inspector and/or architectural firm prior to installation of ceiling channel.
- Specify 5 clips per 10 linear feet.
- Available in quantities of 10 or 100.
 - For 40 or less clips, specify 10 packs.
 - For 41 to 100 clips, specify 100 pack.
- If the ceiling is not stable, reinforcement may be necessary through the use of suitable materials above the ceiling grid system or the drywall soffit ceiling. This reinforcement work is not included in Allsteel's scope.
- Ceiling clips are not utilized in seismic zones.
- The $\frac{3}{16}$ " fineline clip with $\frac{1}{8}$ " reveal can be specified for interlude $\frac{3}{16}$ " grid.
- The tbolt clip is $\frac{3}{16}$ " with $\frac{1}{4}$ " reveal.

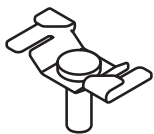

$\frac{3}{16}$ T-Bar Clip

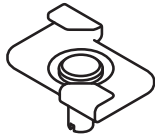

$\frac{1}{4}$ T-Bar Clip



T Bolt

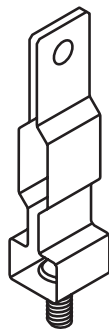

$\frac{3}{16}$ Fineline Clip

Ceiling Grid Tegular Spacer

- Tegular spacers are specifically used where tiles drop below the surface of the grid. There are cases (as with the $\frac{3}{16}$ fineline clip) where tegular tiles are used but they are flush with the surface of the grid so spacers are not needed.
- Specify 5 clips per 10 linear feet.
- Available in quantities of 10 or 100.
 - For 40 or less clips, specify 10 packs.
 - For 41 to 100 clips, specify 100 pack.

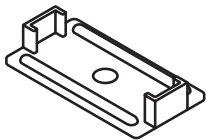

Tegular Spacer

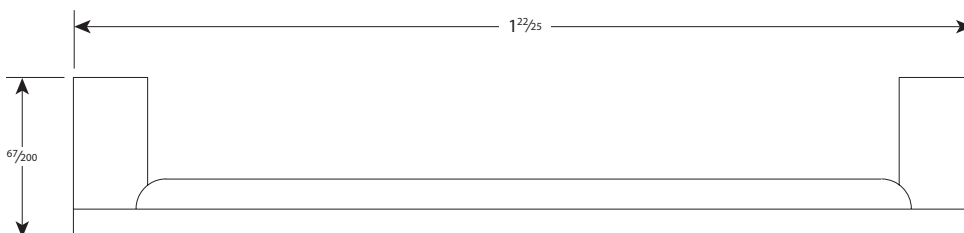

Ceiling Channel

- Ceiling channels are the first component installed in the installation process and can be shipped and installed ahead of the panels. This part is universal and used to connect frameless, framed and solid panels to the ceiling or grid above.
 - A connection to a drywall header utilizes screws provided by the installer through a drywall layer into a ceiling stud or soffit header.
 - A connection to a ceiling grid utilizes non-defacing ceiling channel mounting clips.
- Ceiling channels are mitered at 90° corner conditions and come with end caps to finish exposed ends.
- The top of the panel frame in a framed/solid panel or ceiling brackets in a frameless panel connects with the ceiling channel to support the top of the panel.

Frameless Glass

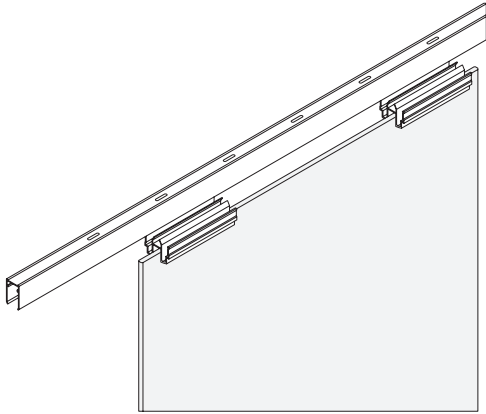

Framed and Solid

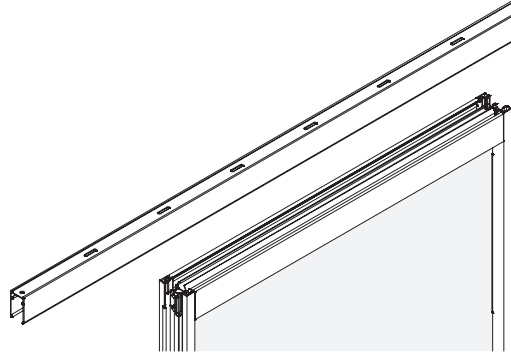

Ceiling Channel Splice Kits

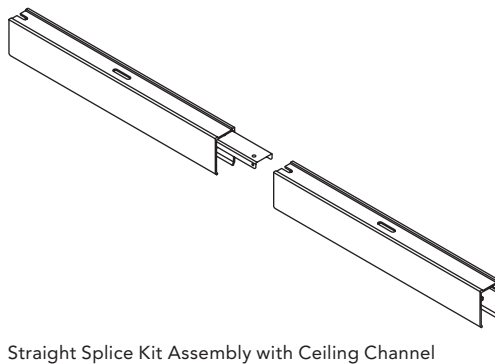
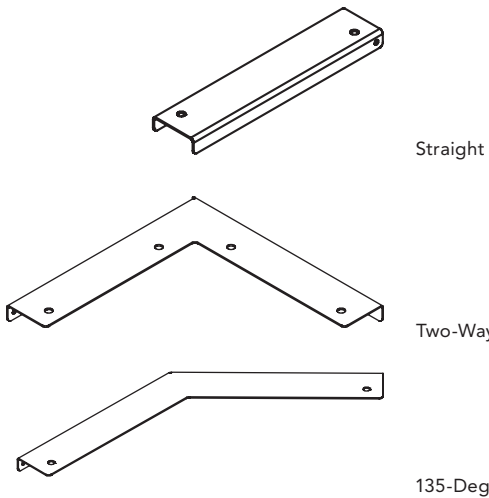

- To connect ceiling channels together, ceiling channel splice kits should be used at straight, two-way, and 135-degree connections. Splice kits provide alignment and mitigate light and sound transference.
- Specification Detail:
 - Specify when runs are over 10 feet.
 - Specify one straight splice kit for every 10 linear feet.
 - Splice kits should also be specified at two-way and 135-degree connections (QTY 1 per connection).
 - Straight splice kits are used across three-way vertical fillers in long runs.

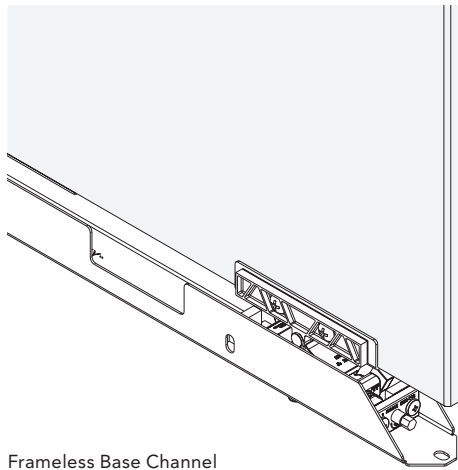

Frameless Base Channel

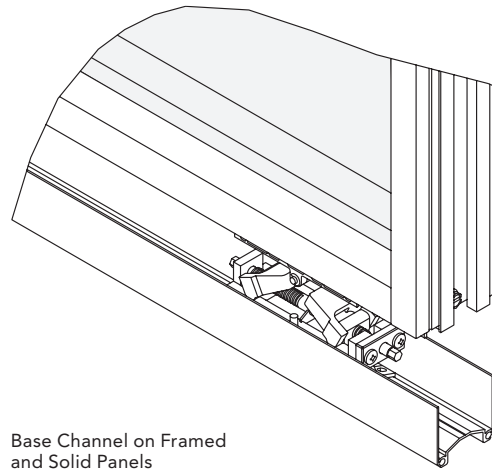

Base Channel on Framed and Solid Panels

- Base channels are included as part of the factory-assembled unitized construction on all three types of Beyond panels (frameless, framed and solid). The base channel houses the leveling mechanisms and supports the weight of the panel.
- Base channels are non-defacing unless required by code or in seismic zones C-F.
- Patented scissor-lift leveling mechanisms are contained within the base channel and provide fast and easy leveling of the panel with a simple power tool.
- On framed and solid panels, the base channel flipper door pivots outward to provide access to the scissor-lift mechanism. The base channel and flipper doors are the same component in both standard and electrical base options. The base height difference for framed and solid is accommodated by utilizing a one inch taller scissor-lift mechanism for the electrical base.

Leveling Capability

Patented scissor-lift mechanisms provide fast and easy leveling with a simple power tool adjustment. Beyond panels are shipped at the ordered height of the panel with the scissor-lift mechanism in the nominal position. Leveling capability in the base is $\pm \frac{3}{4}$ " ($1\frac{1}{2}$ " travel range) and allows for $\pm \frac{3}{4}$ " float in the ceiling channel. These two dimensions are independent of each other. It is recommended that specifiers select a common panel height across a run.

Beyond Frameless

With frameless glass, the scissor-lift mechanism connects the glass to the floor channel. The glass is leveled independently from the base trim. Once the panel is level, the base trim is installed and remains flush with the floor for a clean aesthetic.

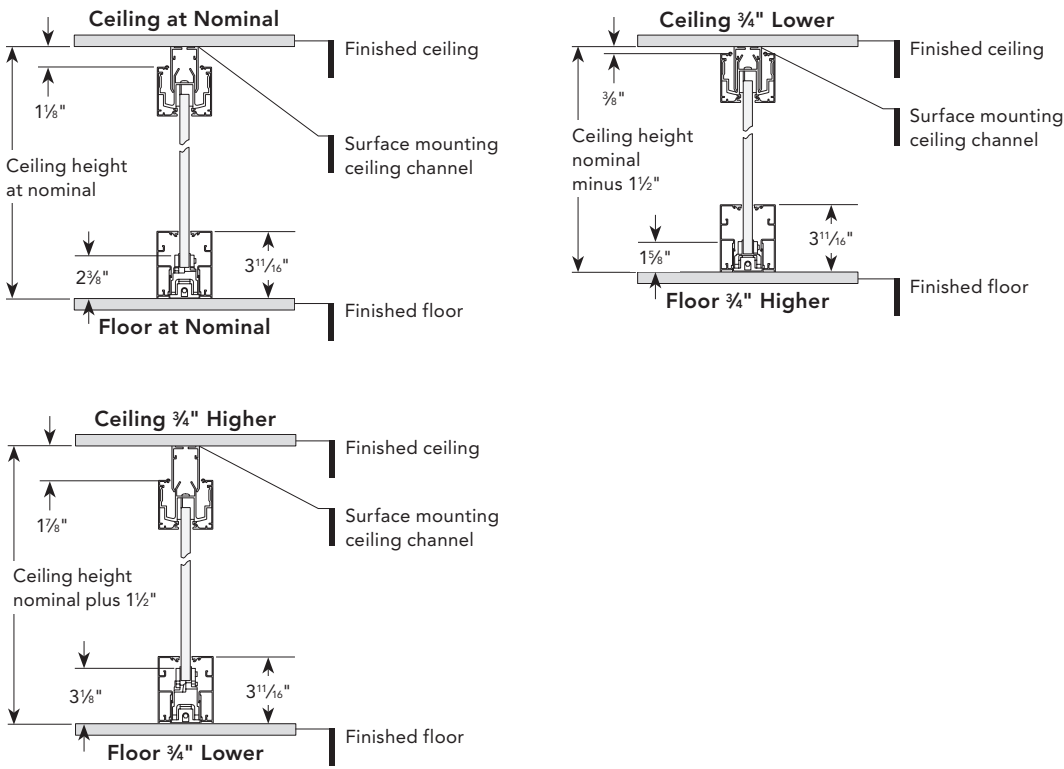

Beyond Framed and Solid

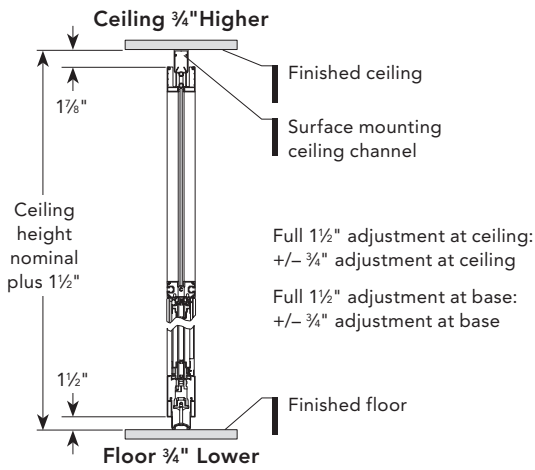
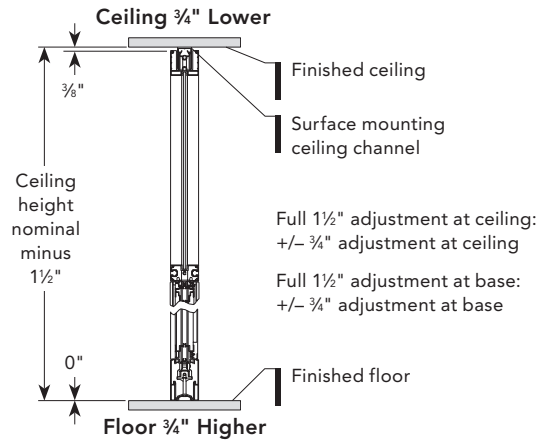
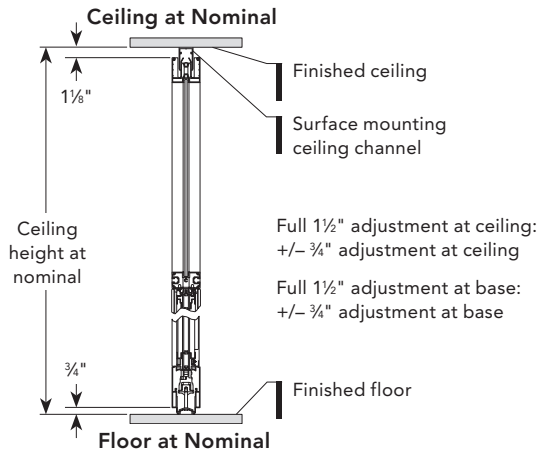

Enhanced Acoustics

- Enhanced acoustical upgrades are now available. Ceiling grid clamp down clips are now included with every order of ceiling grid clips, all electrical and data ported trim for framed and solid panels comes with enhanced gasketing, and standard upgrades are included with every order at no extra cost. Enhanced options can be specified for framed and solid panels and all sliding doors except thin aluminum framed sliding doors.
- Standard Option
 - Includes a modification to the panel frame assembly for tighter acoustic seal.
- Enhanced Option
 - Modification to top horizontal of unitized framed panel to minimize reverberation with ceiling channel.
 - Modification to allow for track and bottom seals on all sliding door types.
 - Retrofit kits available to add enhanced options Day 2 for framed and solid panels and doors. Panels and doors must have been ordered after the launch of the acoustical enhancements to allow proper fit of retrofit kits.

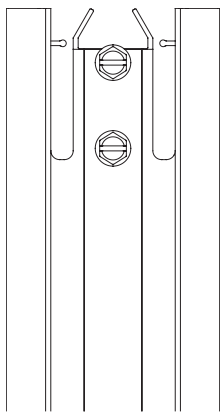

Framed Panel with Enhanced Acoustics

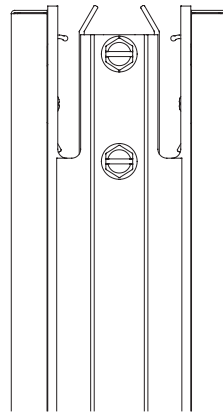

Solid Panel with Enhanced Acoustics

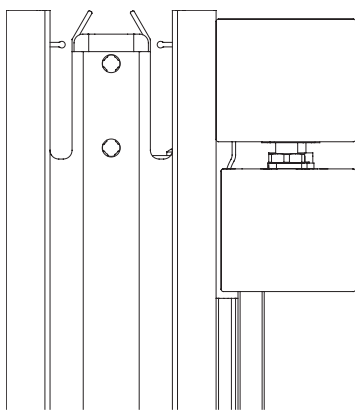

Sliding Door Track with Enhanced Acoustics

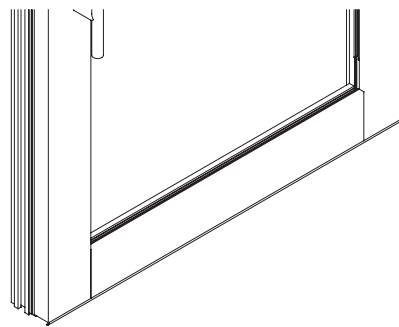

Aluminum Framed Door with Enhanced Acoustics

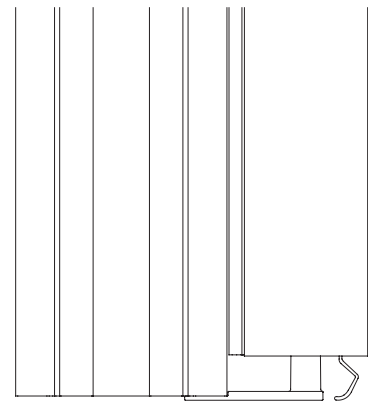

Solid Door with Enhanced Acoustics

BEYOND TABLE OF CONTENTS
 BEYOND FINISHES & FABRICS
 BEYOND PANELS & TRIM
 BEYOND DOORS
 BEYOND CONNECTORS
 BEYOND ELECTRICAL & DATA
 BEYOND FRAMELESS PRIVACY TILE SYSTEM
 BEYOND VIZ

Beyond glass comes in a variety of thicknesses and opacities. All Beyond glass meets ANSI Z97.1 safety glass standard. Different types of glass can be specified to boost acoustic properties, add visual privacy, or create an artistic look.

Glass Thickness Options

- Beyond Frameless: 1/2"
- Beyond Framed and Solid with integrated glass:
 - 1/4"
 - 3/8"

Glass Types

- Tempered glass is one sheet of heat-treated safety glass.
- Laminated annealed glass is made of up two pieces of safety glass that are secured together with an interlayer. Laminated glass boosts acoustic properties and typically carries a higher STC rating.
- Performance or high acoustic laminated glass further boosts acoustic properties. A thin, transparent film is placed between the sheets of laminated glass that reduces sound travel and gains additional STC points.

Glass Colors

- Clear glass has a slight greenish hue when glass is viewed from the edges or side profile.
- Low iron glass is ultra-clear and of higher transparency and clarity than clear float glass. Generally, the green hue of the glass is reduced. It is typically more expensive than clear float glass.
- Translucent white laminated has a medium light transmission level of 65%, meaning it's semi-transparent.
- White markerboard laminated has a low light transmission level of 10%, meaning it's nearly opaque. The lower the light transmission level, the more difficult it is to see through the glass.

Acoustical Performance

BEYOND	STC Result*	Glass Only
Frameless		
1/2" Laminated Glass with High Acoustic Interlayer	Not Tested	39
1/2" Laminated Glass	36	38
1/2" Tempered Glass	34	36
Framed		
3/8" Laminated Glass	34	36
1/4" Laminated Glass	32	35
3/8" Tempered Glass	31	33 to 34
1/4" Tempered Glass	27	31
Solid		
Steel Tiles, Standard Insulation	44	N/A
Steel Tiles, No Insulation	39	N/A
Wood Tiles, Standard Insulation	44	N/A
Wood Tiles, No Insulation	36	N/A

*STC test results represent testing of a fully assembled wall panel.

Beyond panels and trim are available in painted and anodized aluminum. [See Materials and Finishes for trim finish details.](#)

Frameless Glass Panels



Frameless Panel

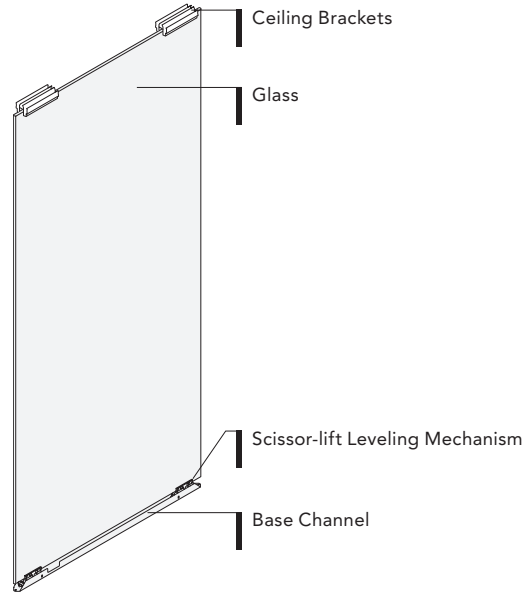

Frameless Panel

- Panel Dimensions
 - Height
 - Min: 18"
 - Max: 120"
 - Width
 - 8"-42" up to 120"H in ¼" increments
 - 42¼"-48" up to 108"H in ¼" increments
 - Glass Thickness
 - ½"
 - For glass colors and types, please see Beyond Glass Information, page 123.
 - Assembled Panel Thickness
 - 3" in depth at ceiling and base trim
 - Orderable Increments
 - ¼" for height and width
- Specification Notes
 - Glass panels, posts, and associated privacy components can be specified at 18" minimums. This allows for applications such as a clerestory window over drywall.
 - Frameless privacy tile systems must use tempered, perforated glass. [See Frameless Glass Privacy Tile System for details.](#)
 - Width of wall segment is determined by the dimension from the centerline of the vertical filler on one side of the segment to the centerline of the vertical filler on the opposite side of the segment.
 - Actual wall panel width will be ⅝" less than specified wall panel width.
 - Glass arris edge is designed with a double chamfer for a precision fit into vertical fillers. This provides for true modularity and no dimensional creep.
 - If multiple frameless glass panel heights are required within a run, adjacent frameless glass panels are recommended to be within ¼" in height for trim to align at the top.
- Panel ships from factory fully unitized with ceiling brackets, scissor-lift leveling mechanism, base channel attached to glass. Each panel ships with 2 ceiling brackets and scissor-lift leveling mechanisms, unless the width of the panel is less than 18".
- Panel weight is supported at the bottom and base channels are non-defacing (unless anchoring is required by code or for seismic zones C-F).

Frameless Trim

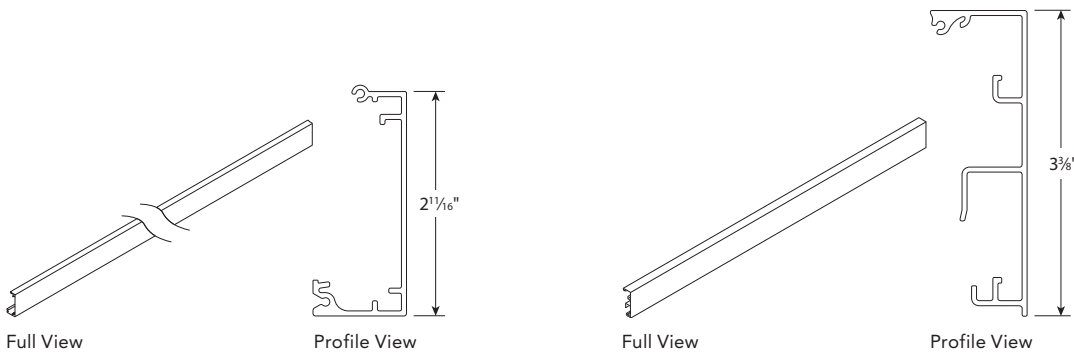

Ceiling Trim

Base Trim

- Base and ceiling trim are both available in 120" lengths. Trim attaches to both sides of the top or bottom on the panel and comes pre-mitered at 90 degree corners. At pre-mitered corners, trim can be specified in 96" lengths (previously 24" and 96"). Both ends are mitered so that it's non-handed, and one end will be cut straight in the field. Polymer gaskets between the trim and glass condition provide an acoustic seal.
- Ceiling trim is 2¹/₁₆"H and attaches to both sides of the ceiling channel "w" brackets that come pre-installed on the top of frameless glass wall panels.
- Base trim is 3¹/₁₆"H and attaches to the base channel of the unitized panel, allowing it to remain flush with the floor for a simple, clean aesthetic.

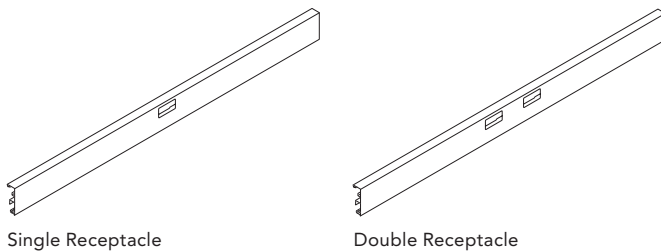

Frameless Electrical Base Trim

- Specify the electrical base trim for modular electrical. [See Beyond Electrical section for details.](#)
- Electrical base trim is available in 48" lengths. Trim attaches to one or both sides of the bottom on the panel. Polymer gaskets between the trim and glass condition provide an acoustic seal.
- Base trim is 3¹/₁₆"H (the same dimension as the non-electrical base trim) and attaches to the base channel of the unitized panel, allowing it to remain flush with the floor for a simple, clean aesthetic.

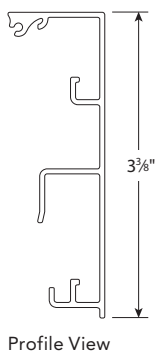

Low Profile Base Trim

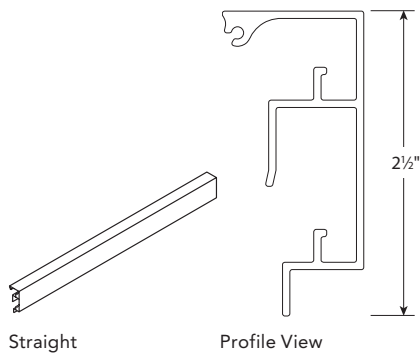

- Non-telescoping with a consistent reveal with the floor for a simple, clean aesthetic. Polymer gaskets between the trim and glass condition provide an acoustic seal.
- Low-profile base trim is 2½"H.
- Available in 120" lengths.
- Adjustment range restricted to +/- ¼".
- Trim is also available as pre-mitered inside and outside 90° corners in 96" lengths (previously 24" and 96"). Both ends of the trim are mitered so that it is non-handed, and one end will be cut straight in the field.
- Specification Notes
 - Depending on floor conditions, continuous runs longer than 20 linear feet may not be feasible with low-profile base trim.
 - Office front applications that start and stop at drywall or that use drywall end caps are preferred for low-profile base trim applications.
 - Floating rail-mounted privacy tiles may be used with low-profile base applications.
 - Full height privacy tile options as well as adjacent privacy tile sets cannot be used with low-profile base.
 - Button-mounted tiles cannot be used with low-profile base applications due to decreased leveling capability in the trim which may cause issues with tile alignment.
 - Modular electrical in the base is not available with low-profile base. For power, utilize electrical ported posts.
 - Due to the limited panel adjustment range, glass panels, frameless wall channels and adapters are ordered at a ½" taller height than nominal height. All other components remain at nominal height.
 - Floor conditions may require multiple frameless glass panel heights within a run.
 - Adjacent frameless glass panel height variability cannot exceed ¼" in height. The height variability resets at door frames.
 - Depending on building conditions, floating the unfinished floor may be required prior to finished floor material installation.
 - Additional time may be required for site measurements and installation due to limited adjustment height and multiple panel heights.

Frameless Trim Keys, Straight Application:

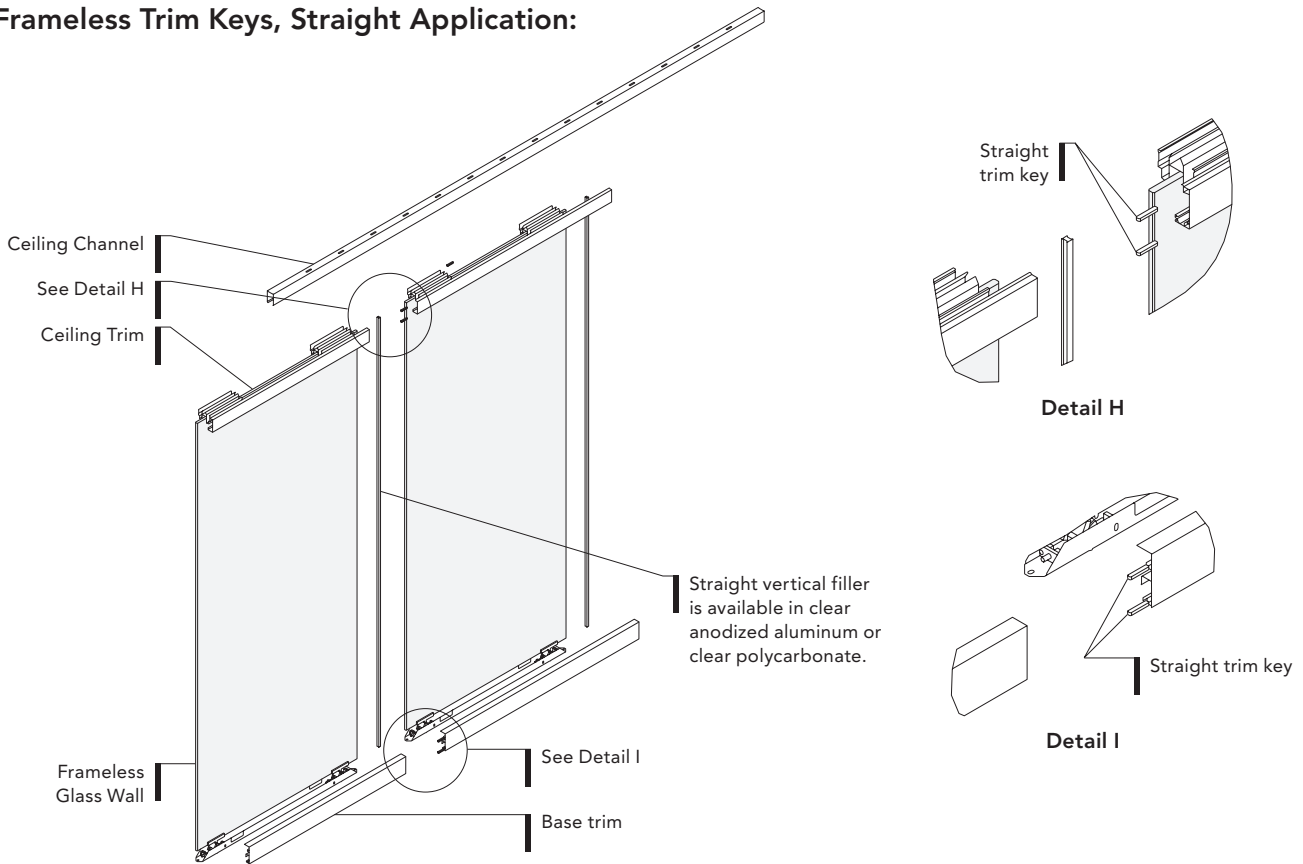

Frameless Trim Keys, Corner Application:

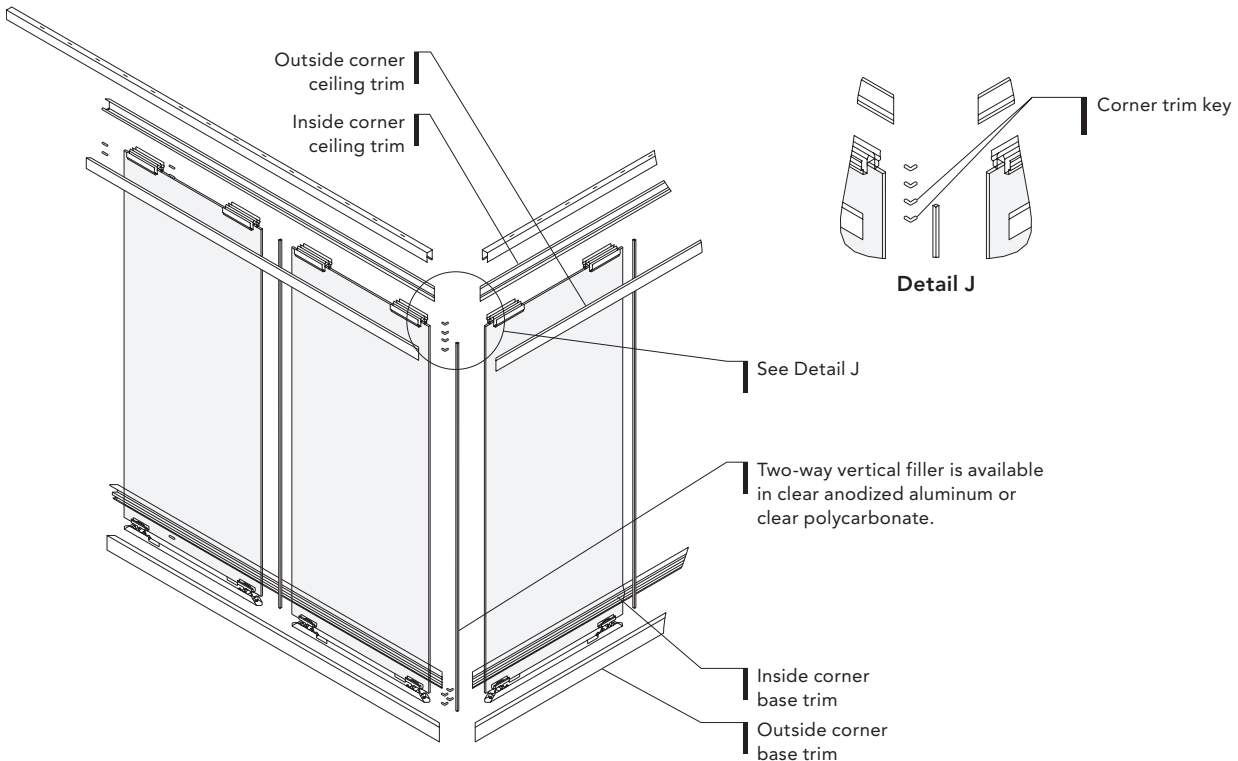

Frameless Trim Keys

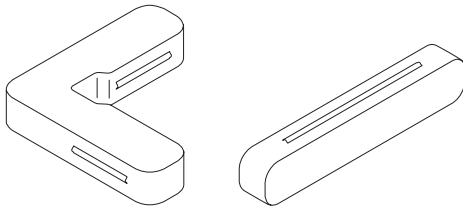

Corner Key

Straight Key

- Trim keys are utilized to ensure proper alignment at straight and corner seams for frameless standard and low-profile base trim and ceiling trim.
- Two trim keys are used at each trim seam.
- Trim keys may be ordered in bulk pack quantities of 50 and 250.
 - For 50 keys or less, specify the 50 pack.
 - For 51 keys or more, specify the 250 pack.
- The number of keys should be specified as follows:

Type	Straight	Two-Way	Three-Way	Four-Way
Straight Keys	8	—	4*	—
Corner Keys	—	8	8	16

QTYs above assume that inside/outside ceiling and base trim is all seamed at the same location.

*QTY (4) straight keys are only needed if outside trim is seamed at a three-way vertical filler. If the application allows, outside trim may span three-way vertical fillers when one 120" length of trim will cover the wall length.

Vertical Fillers

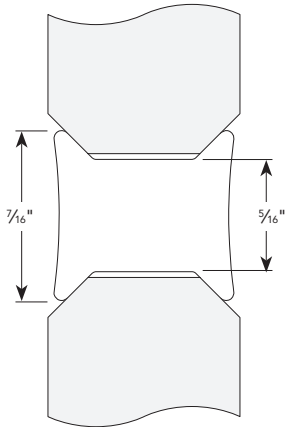

Straight

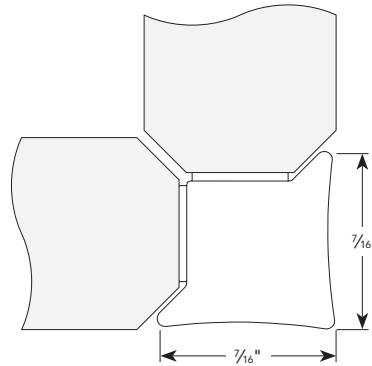

Two-Way

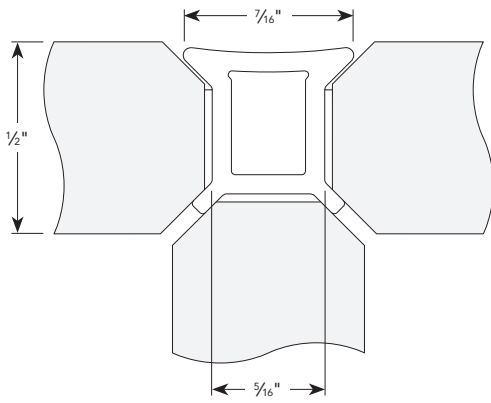

Three-Way

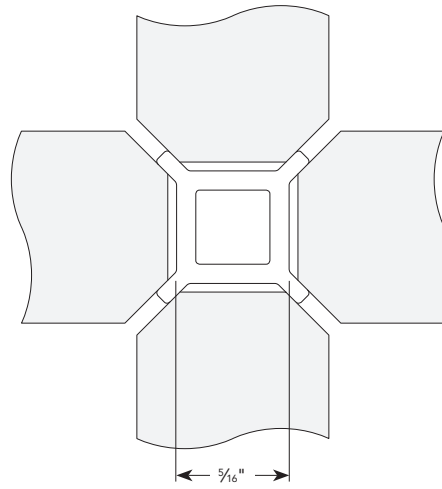

Four-Way

- Vertical fillers provide the connection between frameless glass wall panels.
 - The unique shape of each vertical filler allows 1/2" glass wall panels to be fully modular, meaning each vertical filler shape can be swapped for another to allow different wall configurations without dimensional creep.
 - Frameless glass wall panels are non-progressive and can be added, removed, or reconfigured without disrupting adjacent wall panels.
 - Vertical fillers are attached with a clear double-sided VHB™ (Very High Bond) tape to eliminate the need to caulk or glaze the seams between frameless glass wall panels.
 - Vertical fillers keep the installation clean. By eliminating any need for glazing, they also reduce the need for another trade on the job site.
 - Vertical fillers are available in anodized or clear polycarbonate in straight, two-way, three-way, or 135-degree connection types. Four-way fillers are available in clear polycarbonate only.
 - Vertical fillers are 120"L.
 - Fillers can flex up to 3 degrees to accommodate minimal angles. Angles outside of the 3 degree flex would require the glass to be caulked in the field.
- CET adds 10% to vertical filler quantity for scrap.

Framed Glass



Monolithic

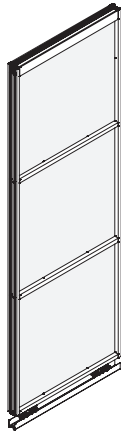

Segmented



With Modular Electrical Base

- Panel Dimensions
 - Height
 - 18"-120" for standard and electrical bases.
 - Up to 144" with stacking - [see Stacking section](#) for additional information.
 - 86"-120" for freestanding.
 - Width
 - 8"-60"
 - Glass Thickness
 - 1/4" or 3/8"
 - For glass colors and types, please [see Beyond Glass Information](#).
 - Assembled Panel Thickness
 - 3" in depth at ceiling and base trim.
 - Orderable Increments
 - 1/4" for height and width.
 - Segmented glass lites available in 1/16" increments. Note that each segment measurement on the framed panel model is from AFF to the top of the segment bar.
- Panels ship from factory fully unitized with panel frame, glass lite(s), integrated ceiling trim, base channel, and scissor-lift leveling mechanism(s), pre-assembled for ease and speed of installation.
- Each panel ships with two leveling mechanisms unless under 18". Only one leveling mechanism is attached to panels less than 18". Panel weight is supported at the bottom and base channels are non-defacing (unless anchoring is required by code or for seismic).
- Panels are non-progressive. A panel can be removed from the middle of a run without disturbing adjacent panels.
- Panels can be segmented with various glass types and can be integrated with solid tiles. See following pages for segmentation pattern rules.
- The electrical base option is 1" taller in height.
- An integrated mounting rail can be specified to allow for attachment of sliding doors with transom, TV mounts, Stride® off-modular connection (for panels up to 57 1/2"), and accessory hooks. This segmentation pattern option was previously specified as S30 and S39. The rules for the integrated mounting rail have been expanded and are detailed in the following pages.

Framed Glass Vertical Styles & Segmentation

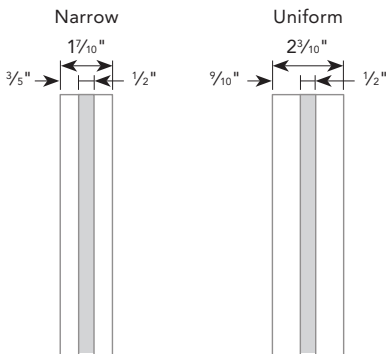

- Framed glass panels come in two vertical styles:
 - Uniform – frame-to-frame with zipper: $2\frac{3}{10}$ "
 - Uniform width on both horizontal and vertical frame members.
 - Optimal for segmented glass.
 - Required when using stacking.
 - Narrow – frame-to-frame with zipper: $1\frac{7}{10}$ "
 - Optimal for monolithic glass.
 - Clean, minimal aesthetic.
 - Not for use with stacking.
 Framed Segmentation Panel Rules.
- Segmentation Pattern Rules:
 - Segmentation patterns are now parametric. Up to 6 glass lites can be specified per panel and segment bars can be moved up/down in $\frac{1}{16}$ " increments.
 - Minimum glass lite sizes
 - Bottom lite with standard base: $11\frac{5}{16}$ " AFF to top of segment bar
 - Bottom lite with electrical base: $12\frac{5}{16}$ " AFF to top of segment bar
 - Bottom lite with integrated mounting rail: $8\frac{3}{8}$ " AFF to top of integrated mounting rail bar
 - Middle lites:
 - 6" minimum distance from top of segment bar to top of segment bar
 - With integrated mounting rail:
 - $6\frac{1}{2}$ " from top of segment bar to top of integrated mounting rail
 - $6\frac{1}{2}$ " from top of integrated mounting rail to top of segment bar
 - Top lite:
 - $8\frac{7}{8}$ " minimum distance from ceiling to top of top segment bar
 - $9\frac{7}{8}$ " minimum distance from ceiling to top of integrated mounting rail bar
 - The previous segmentation patterns will be available as a starting point.
 - Note: while measurements shown in the specification program for segments are from AFF to the top of the segment bar, the measurement in the manufacturing program is from AFF to the centerline of the segment bar. The offset (the distance from the CL of the segment bar to the top) is $.547$ " for a standard segment bar and $.875$ " for an integrated mounting rail segment bar.

- Framed Glass Enhanced Acoustics

- Standard Option
 - Includes a modification to the panel frame assembly for tighter acoustic seal.
 - All electrical and data ported trim for framed panels comes with enhanced gasketing.
- Enhanced Option
 - Modification to top horizontal of unitized framed panel to minimize reverberation with ceiling channel.
- Retrofit kits available to add enhanced option Day 2

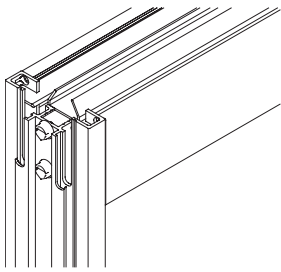

Framed Panel with Enhanced Acoustics

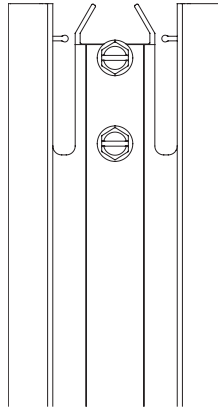

Framed Panel with Enhanced Acoustics

- Solid Panel Enhanced Acoustics

- Standard Option
 - Includes a modification to the panel frame assembly for tighter acoustic seal.
 - All electrical and data ported trim for solid panels comes with enhanced gasketing.
- Enhanced Option
 - Modification to top horizontal of unitized framed panel to minimize reverberation with ceiling channel.
- Retrofit kits available to add enhanced option Day 2

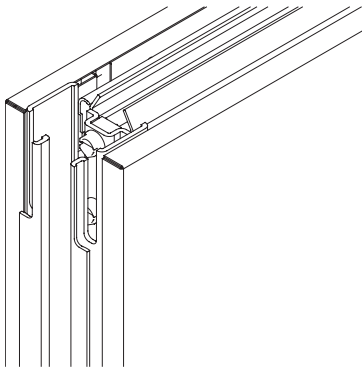

Solid Panel with Enhanced Acoustics

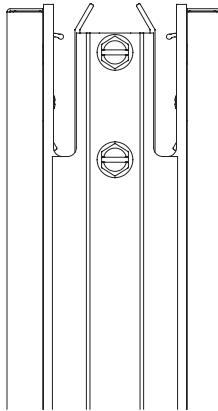

Solid Panel with Enhanced Acoustics

Framed Wood Slat Infill Panels

The Beyond Cabana application utilizes Beyond framed wood infill panels for integration of partially private spaces. This new materiality creates a soft, organic aesthetic for a statement piece that can be designed into a solo, team or booth setting.

The Beyond wood infill panels are shipped with wood slats attached to a metal frame, with the Beyond scissor-lift leveling mechanism attached to the bottom of the panel inside a base channel. The Beyond framed wood infill panels utilize a uniform Beyond frame with wood slats infilling the frame instead of glass. The wood infill panels connect to panels and posts utilizing the same specification rules as Beyond framed glass. Beyond framed and solid trim is installed to cover the base channel and create a finished look. These panels can only be specified in a freestanding application and come in set widths and heights. The panels follow the Beyond framed and solid freestanding rules.

Beyond framed wood infill panel dimensions:

- Height options: 96", 102", 108", 114", 120"
- Width options: 24", 30", 36", 42", 48"

Panels can be specified with standard or electrical base heights. Base heights come in the same dimensions as a Beyond framed glass panel. For ported trim in an electrical base, order trim separately for field installation.

Solid Panel Assembly

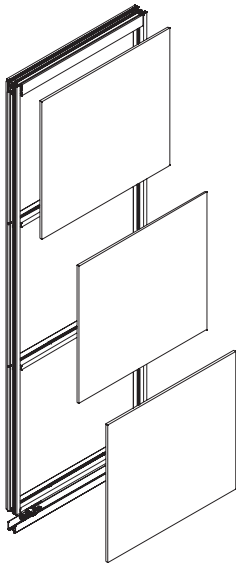

- Solid panels consist of a frame and tile construction, shipped fully assembled from the factory.
 - Frames are constructed of mechanically fastened extruded aluminum components.
 - A minimum of two intermediate horizontal supports per frame provide tile attachment and frame structure.
 - The top horizontal of the frame interconnects with the ceiling channel upon installation.
 - The bottom horizontal connects to the scissor-lift leveling mechanisms, attaching the base channel to the frame structure.
 - Panels can be specified with standard insulation, which consists of two-pound, two-inch thick formaldehyde-free (NAUF) fiberglass included in the cavity of the solid wall.
 - Panels are available without insulation but this is not recommended for optimal acoustics.

- Panel Dimensions
 - Height
 - 18"-120" (previously 86") for standard and electrical bases
 - Up to 144" with stacking - [see Stacking section for additional information](#)
 - 26" minimum height with integrated glass for standard and electrical bases
 - 86"-120" for freestanding
 - Width
 - 8"-60"
 - 9"-60" for fabric tiles greater than 54.5" high
- Panel Specification
 - Panel model is an assembly of a frame and tiles, meaning that one assembly is ordered which contains all associated components including the panel frame and applicable tiles for both sides including ported tiles.
 - Woodgrain laminate and Stratawood veneer tiles are only recommended in a monolithic or base tile. Grain pattern will not align vertically if the panel is segmented.
 - Natural veneer tiles are only available in a monolithic or base tile.
 - Glass markerboard tiles are not available on top tile on solid panel adjacent to trailing side of sliding door without stacker including integrated mounting rail. Only applies to side of panel where track is mounted.
 - Steel Markerboard Tile: 115"x50" is the max size for steel markerboard (previously called laminite) independent of orientation.
 - Assembly Model only contains a Configuration ID, which contains all information for the solid frame and tiles. The Configuration ID can be expanded out in the specification program (CET). Note that model logic details for the frame and tile models can be expanded out in the specification program. However, the base models for the frame and tile models will NOT show up in the specification program. Base models will only appear if the frame and/or tile(s) are ordered separately, for example as a field-installed component.
- Back-painted glass markerboards can be ordered as a stand-alone component to attach to drywall or other building materials. Order model BY-GLASSWALLMB through the CET Picklist for the stand-alone markerboard. Markerboard comes with mounting hardware.

Solid Panel Frames

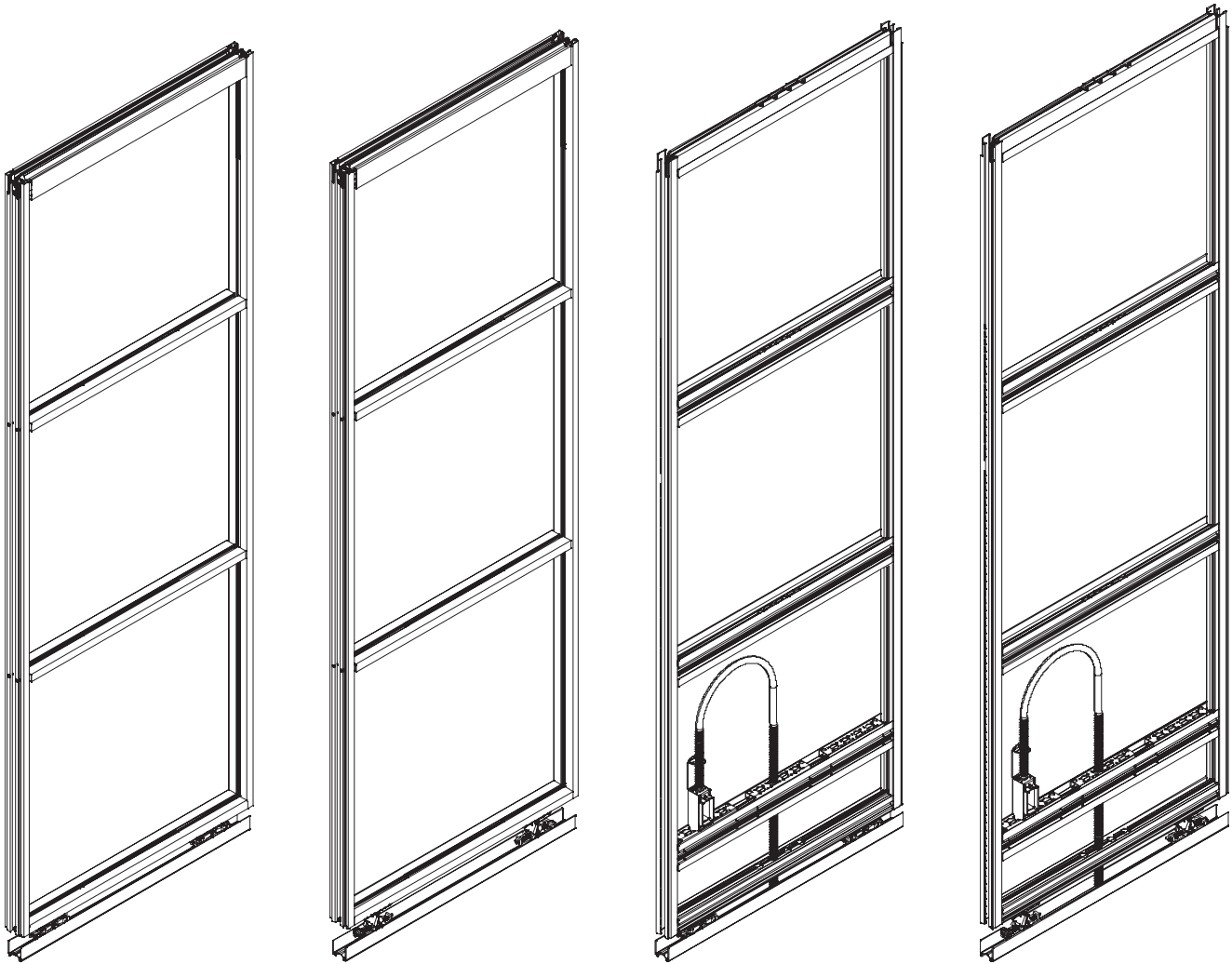

- Solid frames can support modular electrical in the base and/or hardwired electrical with ported tiles.
 - Electrical frames are a sub-option listed within the Configuration ID of the standard frame model.
 - Electrical frames and ported tiles are incorporated into the solid panel assembly.
 - Modular electrical base frames allow for the routing of modular electrical through the base of the panels. Frames have pre-milled locations in the base for powerblock attachment.
 - Electrical frames have junction boxes and conduit installed and allow for wiring without the removal of tiles. A pull string is routed through the conduit to allow the electrician to tie on the wire and pull through the conduit to the junction box. Hardwired electrical tiles come pre-ported. Various positions of receptacle ports are possible in left, right, or centered horizontal positions. Vertical positions for j-boxes are available in .001" increments. Electrical frames can be specified with ported and non-ported tiles. Specify ported tiles where receptacles will be placed. Painted steel, fabric-wrapped, veneer and laminate tiles can be ported.
 - See the [Electrical section](#) for additional details.

Solid Panel Tiles

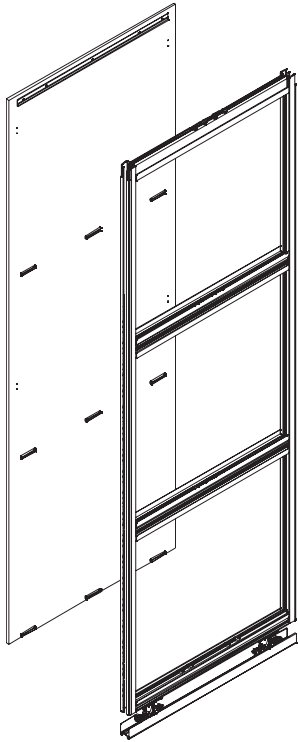

Tiles are constructed with clips on the back of the tiles for easy removal and reconfiguration. Tiles mount vertically on a single wall frame. A variety of tile materials are available on solid panels. Solid tile material type options include:

- Painted Steel
 - Consists of 20-gauge formed steel pan with textured and matte paint finish options.
 - Tiles can be ported to support hardwired electrical receptacles.
- Fabric-Wrapped
 - Smaller tiles are constructed with fabric wrapped around a steel pan.
 - Larger tiles consist of fabric-covered NAUF (formaldehyde free) insulation including a 20-gauge steel pan for sound blocking. Fabric is glued to fiberglass.
 - Tiles can be ported to support hardwired electrical receptacles.
- Veneer
 - Consists of veneer-covered particle board core. Balanced construction with matching edge.
 - Stratawood and natural veneer finish options.
 - Natural veneer is only available as a monolithic tile or single tile (no grain matching).
 - Tiles can be ported to support hardwired electrical receptacles.
 - Grain runs vertical.
- Laminate
 - Consists of laminate-covered particle board core. Balanced construction with matching edge.
 - Tiles can be ported to support hardwired electrical receptacles.
 - Grain runs vertical.
- Glass Markerboard
 - Consists of $\frac{1}{8}$ " thick tempered, low iron, back-painted glass adhered to an aluminum frame structure to provide finished edge and support tile attachment clips.
 - Optional magnetic backing can be added and requires use of rare earth magnets.
 - Glass markerboard can be specified as part of a Beyond solid panel assembly or as a separate component to mount to drywall or other building material type.
 - To the floor back painted markerboard solid tiles available as an ETO option only.
- Steel Markerboard
 - Consists of polyester film co-laminated over a steel magnetic sheet in a smooth white finish.
 - Dry erase magnetic writing surface.
- Integrated Glass Tile / Stacker
 - Framed glass can be integrated into solid panels and become part of the solid panel assembly.
 - All stacking tiles consist of framed glass and are not pre-assembled to the panel. Stacking panels are field-installed. For more information on stacking panels, please turn to page [148](#).
 - See page [151](#) for additional details.

Framed and Solid Electrical and Data

Note that segment bars are counted from bottom to top, so Segment 1 is the first segment bar AFF.

Segment 1 AFF Placement

- With standard base trim
 - 7³/₄" minimum AFF with junction box attached above the segment bar with horizontal options of Left / Center / Right position. Conduit can route up or down.
 - 13⁵/₁₆" minimum AFF with junction box attached below segment bar with horizontal option of Center position. Conduit can route up or down.
 - 16⁵/₁₆" minimum AFF with junction box attached above segment bar with horizontal option of Left or Right position. Conduit can route up or down.
- With electrical base trim, the minimum allowed bar placement increases by 1". All other rules are the same.
- Maximum placement of Segment 1 is 46³/₄" AFF.

Top Segment AFF Placement

- To avoid interference with top channel, the top segment must observe the following minimum distances from the top:
 - 5³/₄" minimum distance from the ceiling / top for a junction box attached below the segment bar with horizontal options of Left / Center / Right position. Conduit can route up or down.
 - 13¹/₄" minimum distance from the ceiling / top for a junction box attached above the segment bar with horizontal option of Left, Right or Center position. Conduit can route up or down.

Segment 2-8 AFF Placement - when not used as top segment

- These segments, when used between Segment 1 and the Top Segment, must follow these minimum dimensions:
 - 3¹/₂" minimum space between 2 adjacent segment bars
 - 9¹/₂" minimum space when there is 1 junction box located between the adjacent segment bars in the Center position
 - 12¹/₂" minimum space when there is 1 junction box located between the adjacent segment bars in the Left or Right position
 - 21" minimum space where there are 2 junction boxes with the same horizontal alignment above / below in Left, Right or Center position
- The maximum space between these segments is 42³/₄"

Panels & Trim

Beyond® — Working with Framed / Solid Panels & Trim

Single Junction Box with One Conduit Port Location: 18"H AFF:

Note: Electrical Ported Frames for Integrated Glass models all route conduit down.

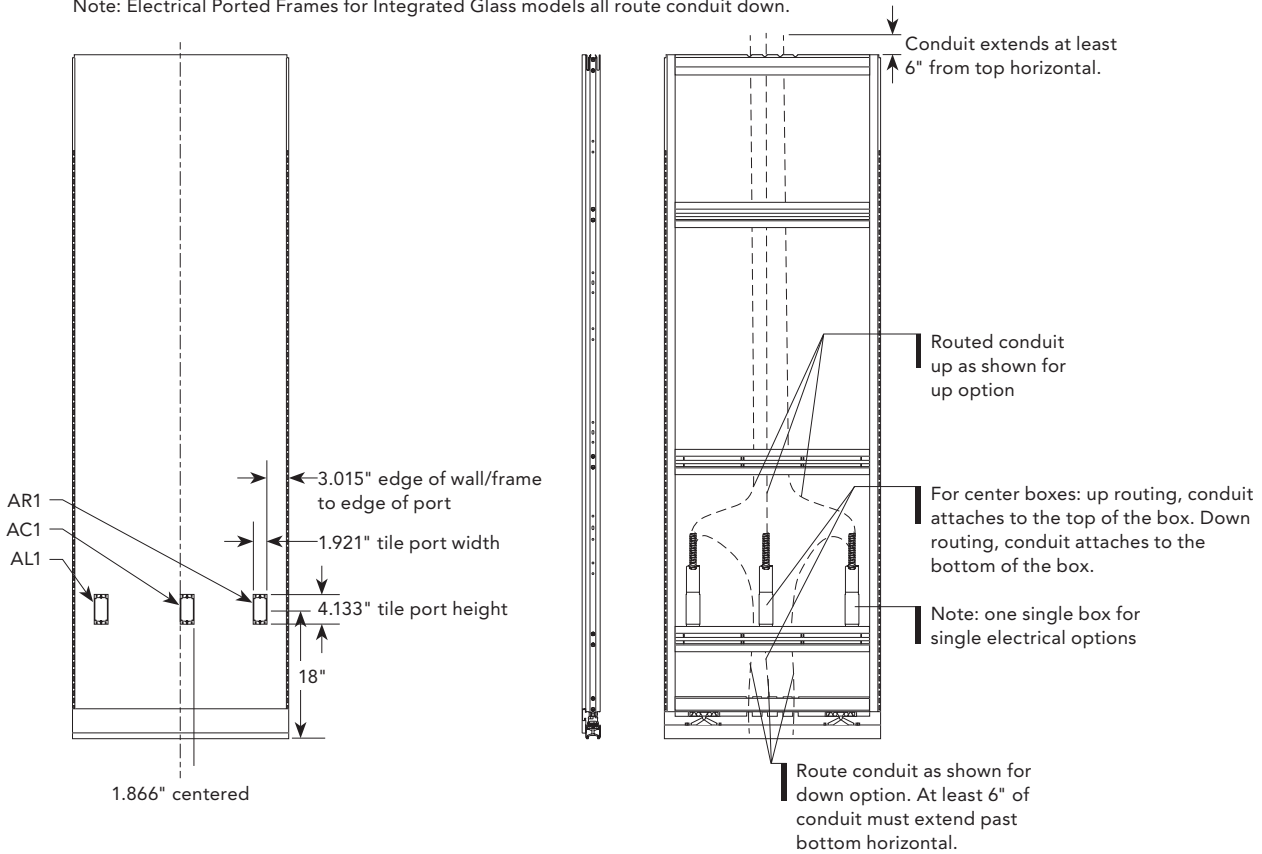

Double Junction Box with Two Conduit Port Locations: 18"H AFF:

Note: Electrical Ported Frames for Integrated Glass models all route conduit down.

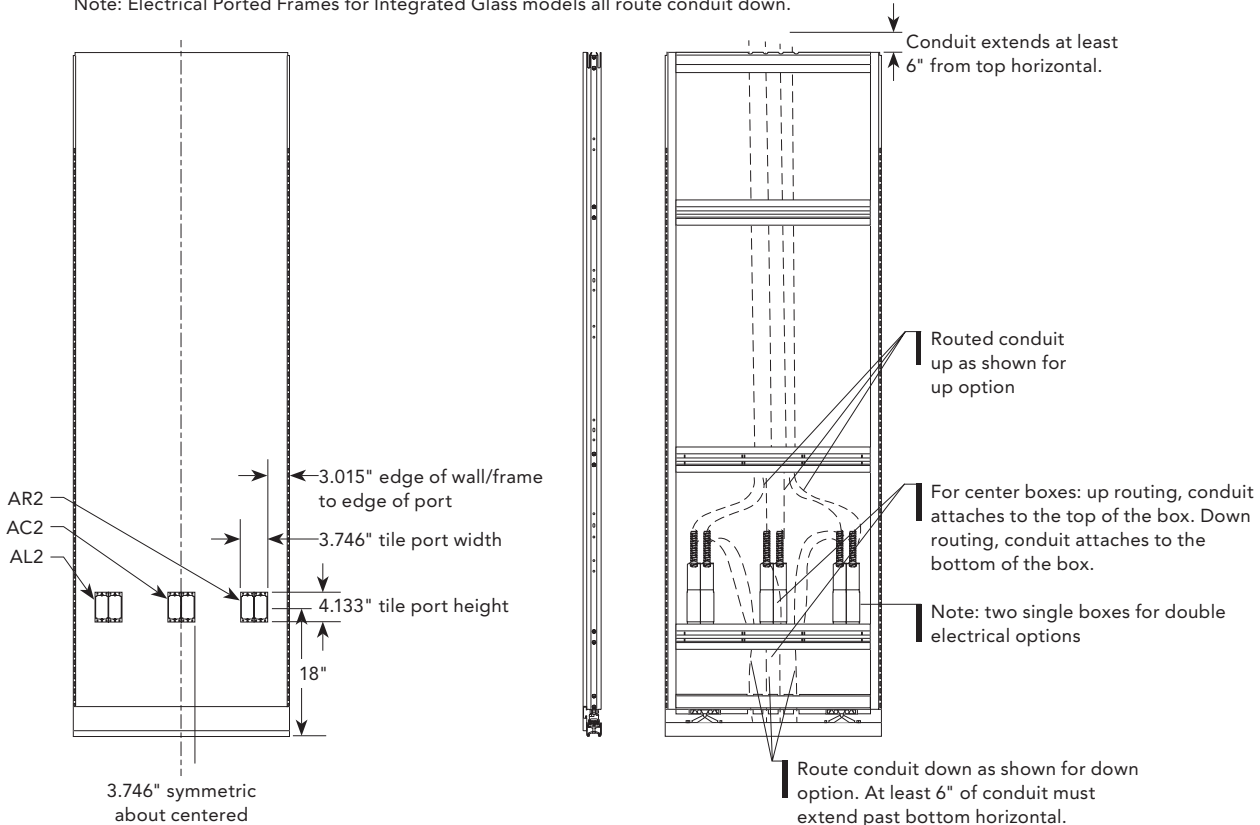

Double Junction Box with One Conduit Port Location: 18"H AFF:

Note: Electrical Ported Frames for Integrated Glass models all route conduit down.

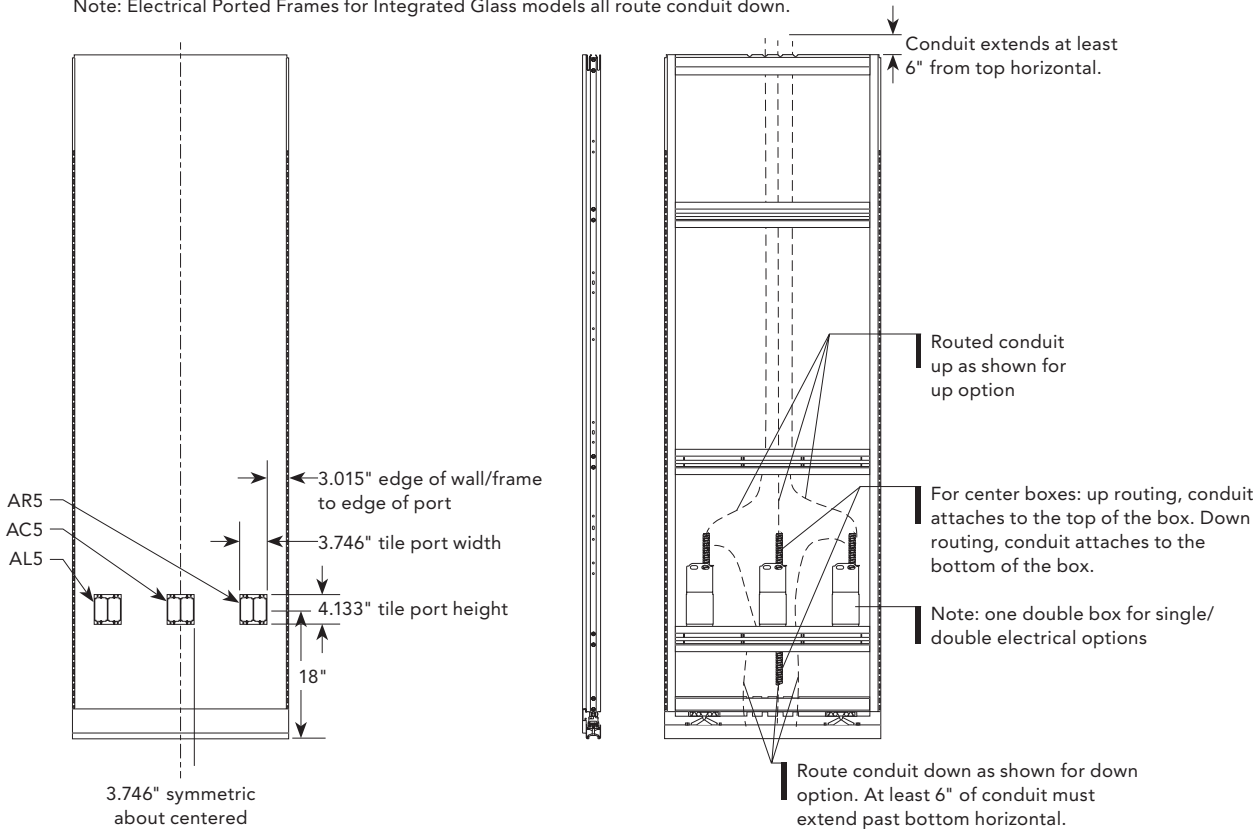

Quad Junction Box with Two Conduit Port Locations: 18"H AFF:

Note: Electrical Ported Frames for Integrated Glass models all route conduit down.

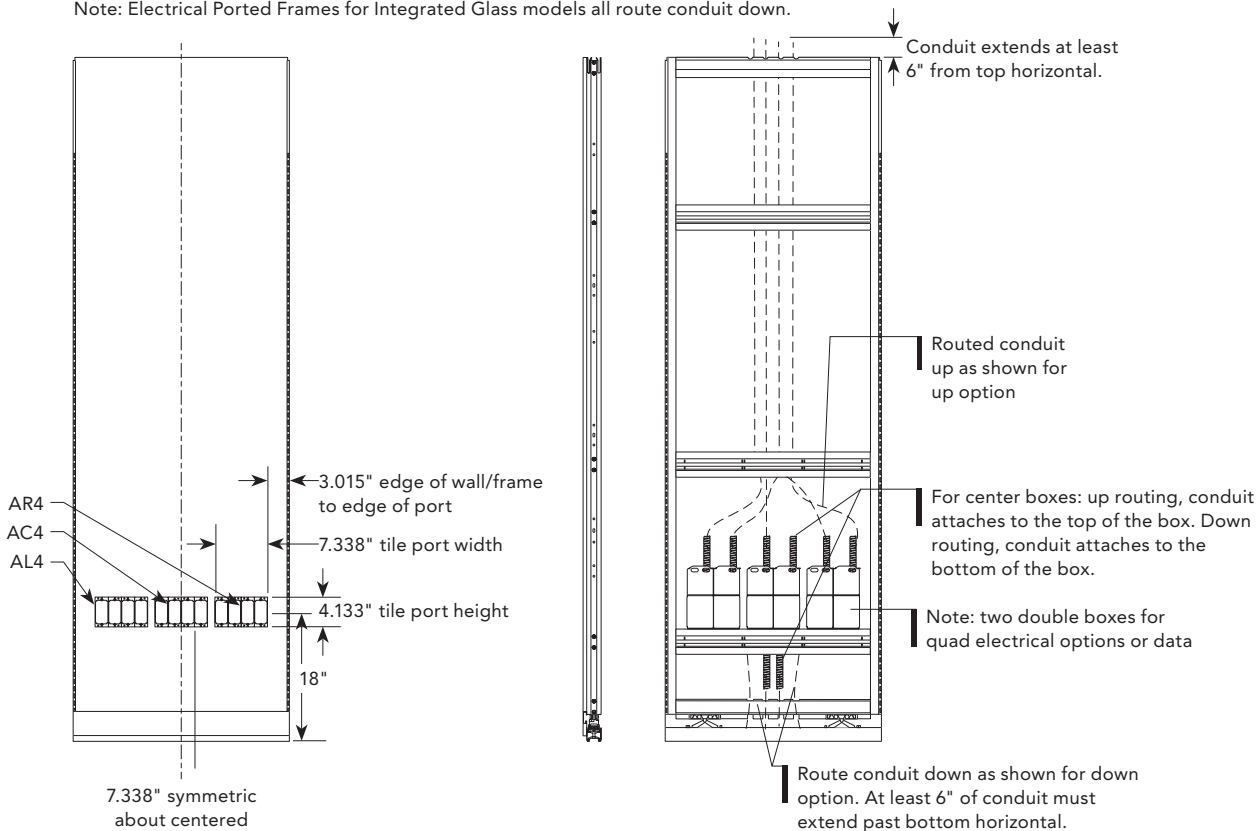

Panels & Trim

Beyond® — Working with Framed / Solid Panels & Trim

Single Junction Box with One Conduit Port Location: 42"H AFF:

Note: Electrical Ported Frames for Integrated Glass models all route conduit down.

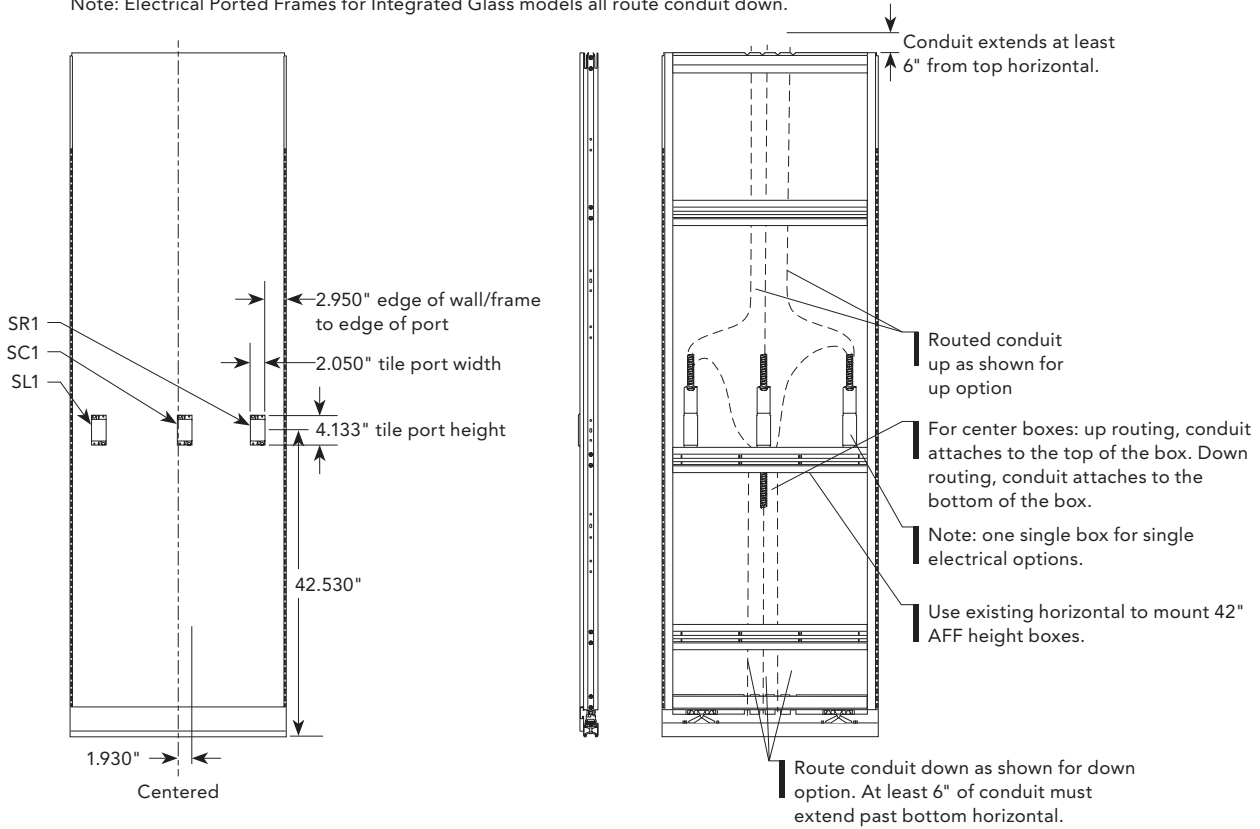

Double Junction Box with One Conduit Port Location: 42"H AFF:

Note: Electrical Ported Frames for Integrated Glass models all route conduit down.

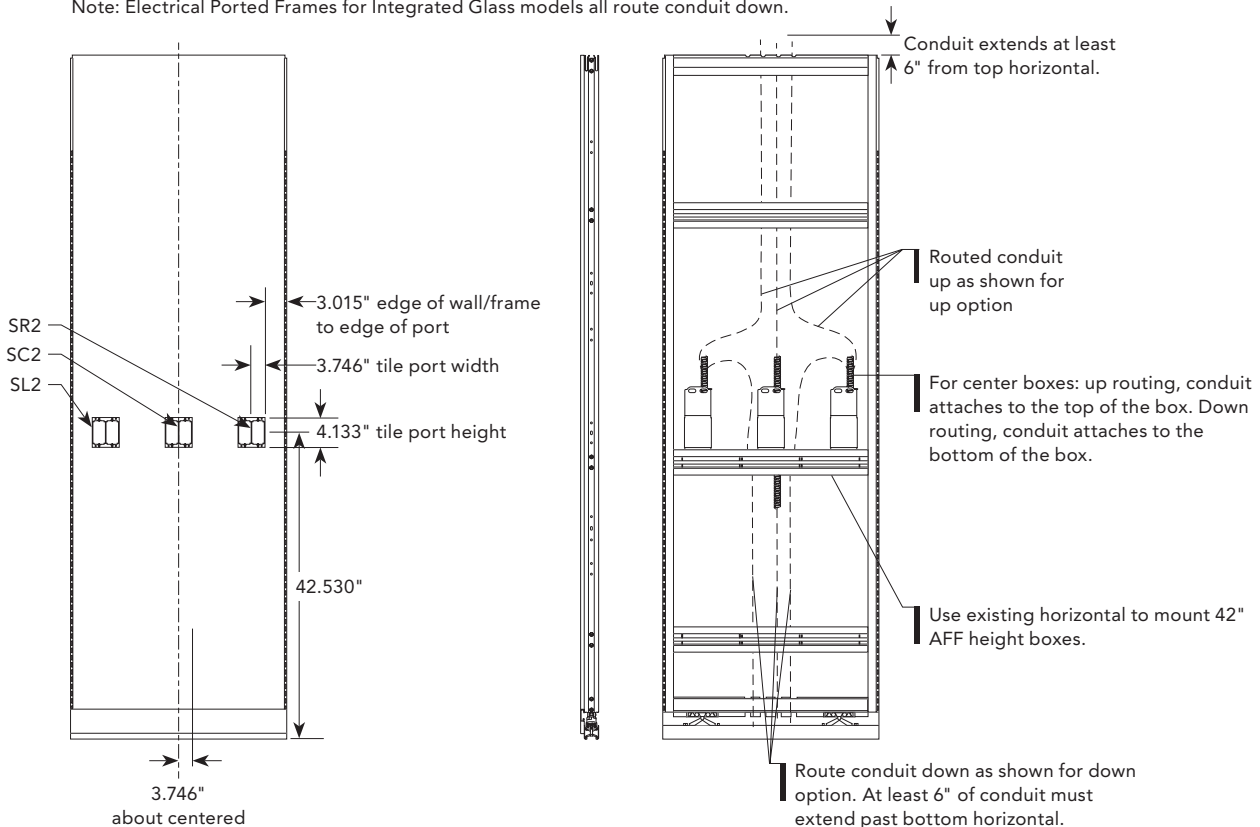

Solid Walls Ported Wall Frames and Tiles for Electrical Routing

Electrical ported solid wall frames have junction boxes and conduit installed and allow for wiring without the removal of tiles. A pull string is routed through the conduit to allow the electrician to tie on the wire and pull through the conduit to the junction box.

Solid walls including the junction boxes, conduit, and connections are UL Listed under Sections and Units file number E465543. Conduit is UL Listed flexible metal conduit ½" trade size. Boxes are UL Listed metallic outlet boxes.

Conduit is installed in the factory to be extended 6" from top of panel. An additional 18" is coiled within the frame. Conduit can be extended in the field to a max of 24" from top of panel.

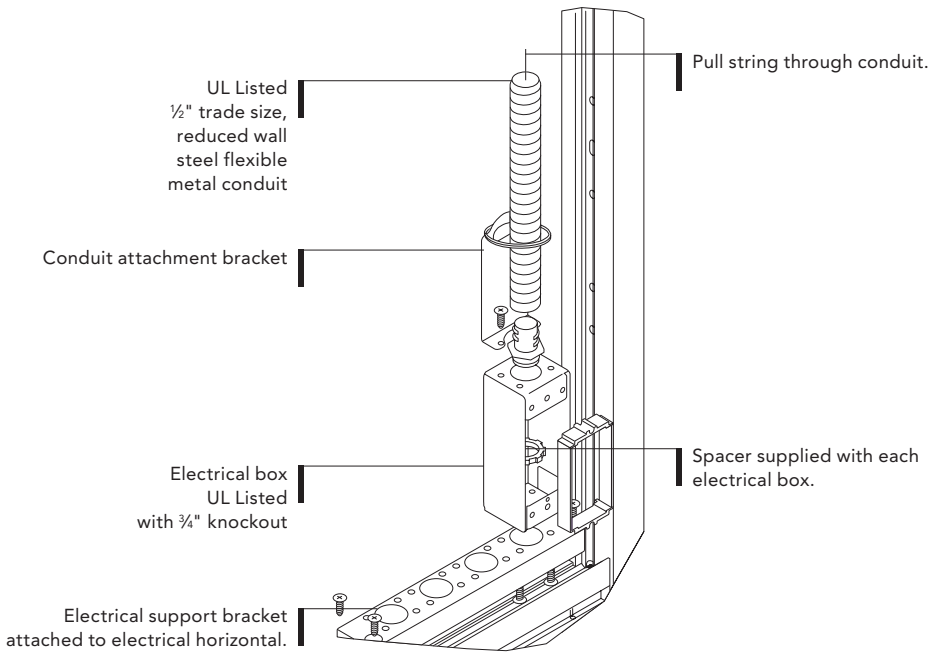

Panels & Trim

Beyond® — Working with Framed / Solid Panels & Trim

Conduit routing can be specified to route up through the top of the wall to support power routing from above. Conduit routing may also be specified to route down into the base channel to support power routing from below. When integrated glass tiles are used, conduit routing must route into the base channel. If power is coming from above, wiring can be routed through the posts and into the base channel in these situations.

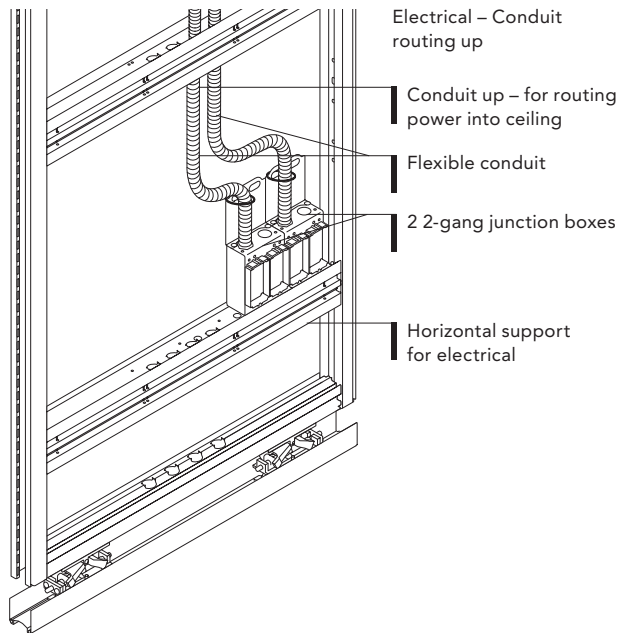

Conduit Routing Up (specify Up option)

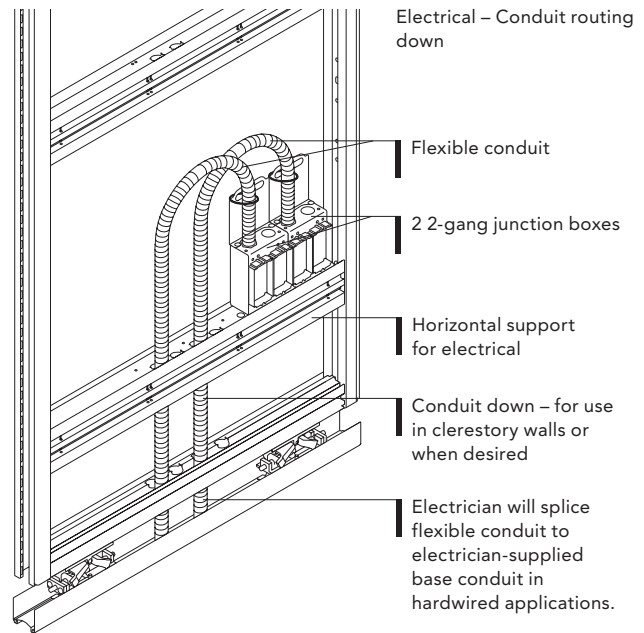

Conduit Routing Down (specify Down option)

Wiring can be routed through wall channels and finished ends, and straight, two-way, and three-way posts to the floor. Wiring may not be routed through a four-way post. Posts with access trim are notched at the base to allow power and data to pass through. Other posts must be field-notched.

When feeding conduit past scissor lifts, conduit size will need to be reduced from 1/2" trade size due to space constraints.

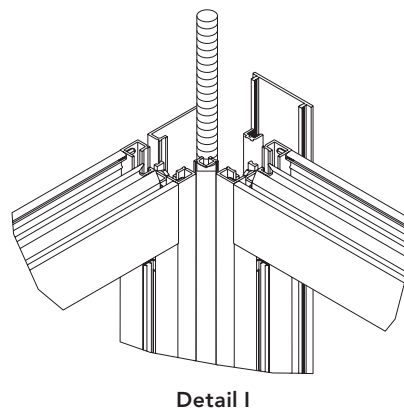
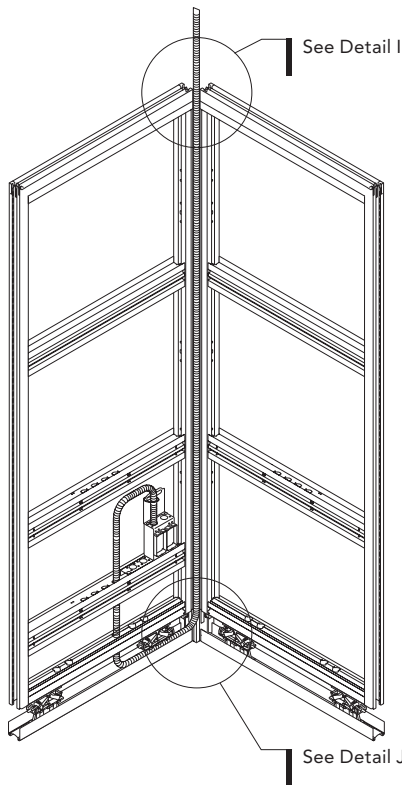

Detail I

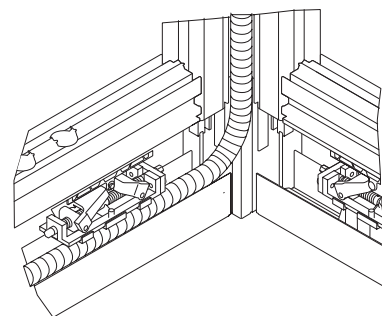

Detail J

Junction boxes are available in single, double, and quad options. Junction boxes are sized to accommodate industry-standard receptacles and faceplates allowing walls to use the same electrical components being used in the building.

- Single boxes have one conduit routing to the box.
- Double boxes have a choice of one or two conduits routing to the box.
 - Utilize two for separation of power and data.
- Quad boxes have two conduits routing to the box.
 - One conduit supports two receptacles for power.
 - One conduit supports the other two device locations for power or data separation.

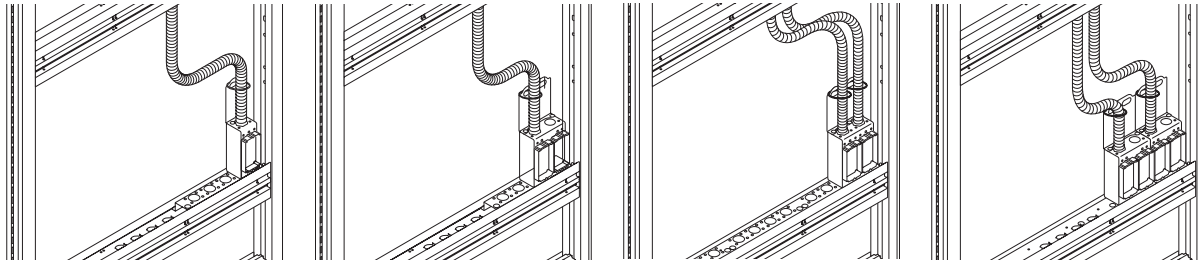

Single with One Conduit

Double with One Conduit

Double with Two Conduits

Quad with Two Conduits

Electrical Ported Frames and Tiles are available with ports on one or both sides. Port locations are specified for Side A and Side B of the frame to identify port locations for each side. Ports can be located on the right, left, or center of the frame. Centered ports are only available single sided. Left or right ports can be double sided (left side on both sides of the frame or right side on both sides of the frame).

Ports can be placed vertically in $\frac{1}{16}$ " increments.

Each solid frame has horizontal supports for stability. Horizontal members are also used to hold junction boxes, which can hang above or below the segment bar.

There are some constraints to junction box location to avoid interference between segment bars needed for frame support and segment bars used to support junction boxes. Minimum distances also must be observed to avoid interference with the top and bottom horizontal members of the frame.

Note also that each frame can support 4 conduits routing up or down. All conduit must route in the same direction. If conduit is to route in different directions, an engineered-to-order panel can be requested. Hardwired power available in solid panels 30"W and larger.

Tile Base

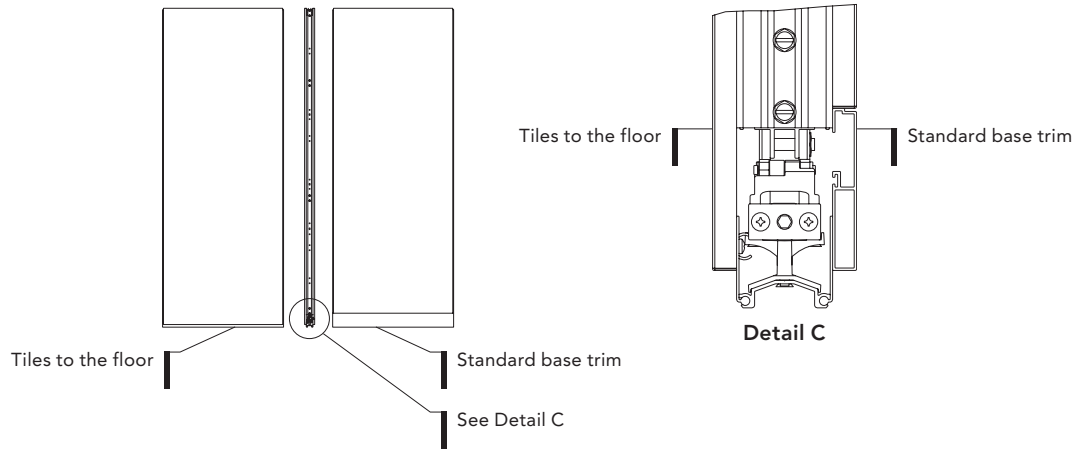

- Solid tiles at the base of the panel can be specified with base trim or with tiles to the floor. Specifying with base trim is recommended for movability as the base trim can be removed for quick and easy access to the scissor-lift leveling mechanism. Specifying with tiles to the floor is recommended for a clean aesthetic when the visibility of the aluminum trim line at the bottom is not desired.
 - Tiles with Base Trim
 - Base trim option required for access to modular electrical when electrical base option is specified.
 - Panels specified with base trim install without removing tiles.
 - Tiles to the Floor
 - Not available with stacking or freestanding applications as the tile cannot be removed from the frame to level the panel.
 - Sized to include 3/4" nominal reveal to allow for leveling.
 - Panels with the tiles to the floor will require the tile to be removed during installation and reconfiguration to provide access to the scissor-lift mechanism or to connect zippers.

BEYOND TABLE OF CONTENTS
 BEYOND FINISHES & FABRICS
 BEYOND PANELS & TRIM
 BEYOND DOORS
 BEYOND CONNECTORS
 BEYOND ELECTRICAL & DATA
 BEYOND FRAMELESS PRIVACY TILE SYSTEM
 BEYOND VIZ

Tile Reveal Type

- Panels can be specified with tiles that have a visible reveal between each tile, or as butt-jointed tiles. Specifying with reveal is recommended for movability as the tiles can be easily moved with quick access to zippers, which fit into the tile reveal. Specifying butt-jointed tiles means the tiles are extended to cover the zipper reveal. This is recommended for a clean aesthetic when the visible zipper reveal.
- Tiles with Reveal
 - Can be specified with a half-inch reveal between tiles for ease of installation and reconfiguration or with butt-jointed tiles for a clean aesthetic.
 - Half-inch reveal is required for vertical furniture integration, stacking and freestanding.
- Butt-jointed Tiles
 - Wall with the butt-joint tile option will require the tile(s) to be removed during installation and reconfiguration.

Tiles with Reveal:

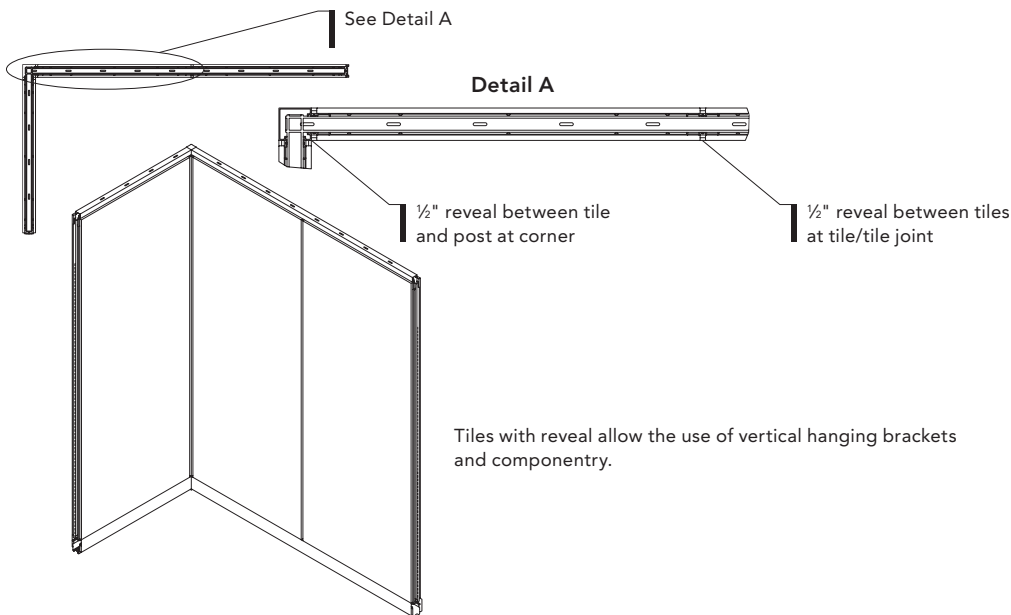

Butt-Jointed Tiles:

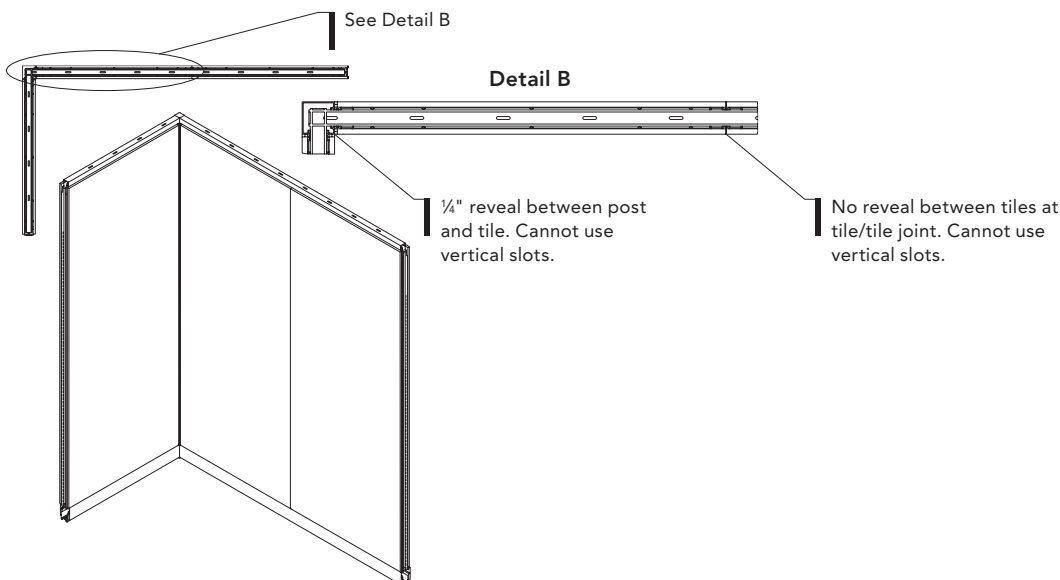

- Beyond Solid Segmentation Panel Rules.
 - Segmentation patterns are parametric
 - Up to 9 tiles can be specified on a solid panel
 - Panel sides A and B may have different configurations as long as they don't interfere with each other
 - All tiles specified for a given side must be the same actual width
 - The selection of "with reveal" or "butt-jointed" applies to all tiles on assembled panel side
 - Previous segmentation pattern codes will remain available as a starting point. Users will not be able to add/remove segments, but can move the segment bars to desired placements up/down.
 - Tile Size Possibilities for non-ported tiles
 - Width - Exact Dimension
 - For Painted Steel, Veneer and Laminate Tiles: 8"W - 60"W in ¼" increments
 - For Fabric-Wrapped: 9"W - 60"W in ¼" increments
 - For Glass Markerboard: 12"W - 60"W in ¼" increments
 - For Steel Markerboard: 8"W-52"W in ¼" increments
 - Height - Exact Dimension
 - Painted Steel, Veneer, Laminate and Fabric-Wrapped Tiles: 6½"H - 118⅞"H in ⅛" increments. When a panel is 120"H nominally, a tile that's specified to the floor will be 118⅞"H.
 - Glass Markerboard and Steel Markerboard Tiles: 6½"H - 114¾"H
 - Note: Steel Markerboard is limited to 52" on one side. It is possible to specify greater than 52" in width up to 60"W, but the height would then be limited to 52"H.

Note that segment dimensions shown in the CET program are from AFF to the center of the segment bar for solid panels.

- Painted steel, veneer, laminate and fabric-wrapped tiles can be ported for receptacles to use with hardwired electrical panels. Tiles can have up to 4 ports in single, double, or quad applications. More than one j-box can be placed on the same side of a panel, although j-boxes cannot be back-to-back.
 - Tile Size Possibilities for Ported Tiles:
 - Width
 - For Laminate, Veneer, Painted Steel and Fabric Tiles: 30"W - 60"W in ¼" increments
 - Height
 - For Laminate, Veneer, Painted Steel and Fabric Tiles: 9¼"H - 118⅞"H in ⅛" increments
 - For placement of junction box within tiles, the following dimensions are required from the center of the outlet to the top or bottom of the tile:
 - Painted Steel
 - For heights up to 78"H: 4⅛"
 - For heights 78"H and higher: 4⅞"
 - Veneer and Laminate Tiles: 4⅛"
 - Fabric-Wrapped:
 - For heights up to 78"H: 4⅛"
 - For heights 78"H and higher: 4¾"
 - There must be 12¼" between junction box.

Solid Panels with Integrated Glass

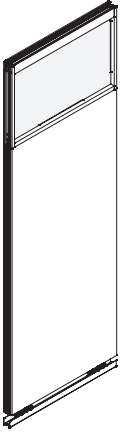

Beyond framed glass can be integrated into Beyond solid panels. Framed glass should always be specified above any solid tiles on the panel. Note that overall panel height for a solid panel is 18"H - 120"H. There must be a minimum 18"H solid panel with tile(s) below the integrated glass.

- Integrated Glass Tile Possibilities
 - Width:
 - 8"-60" in ¼" increments
 - Height:
 - 9½" - 102"H in ¼" increments
 - 10½" - 36⅞"H in ¼" increments with integrated mounting rail
- Specification Information:
 - When specified, framed glass will become part of the solid panel assembly.
 - Integrated glass utilizes uniform width vertical style on the frame.
 - Select from ¼" and ⅜" Beyond framed glass in a variety of colors and types.
 - Note that base model for integrated framed glass BY-STILEGLASS is the same base model as a framed glass stacker. See the following page for additional information about a framed glass stacker.

Solid Spanning Tiles

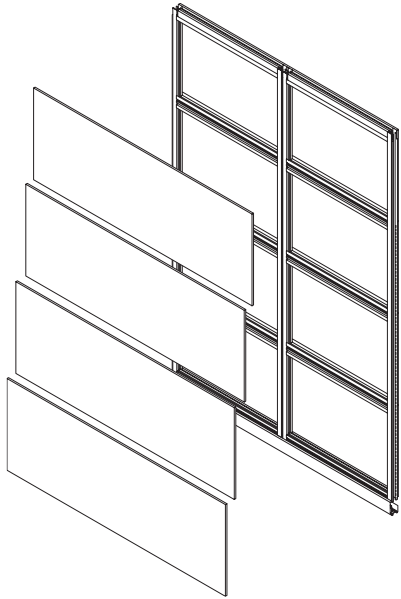

– Tiles can span across multiple frames. This can create a clean aesthetic such as when a markerboard tile spans across multiple frames when a seam is not desired within the markerboard. Spanning tiles are engineered-to-order.

- Standard tiles mount vertically on a single wall frame.
 - Available in widths up to 120" wide x 52" high.
 - **Must be field-installed.**
 - Allsteel recommends utilizing frames of the same width for spanning so that tiles do not become handed tiles.
 - Spanning tiles must span to the edge of the frames where the vertical supports are located to provide light and sound seal.
 - Frames and tiles will ship separately and be installed in the field when spanning tiles are specified.
 - Spanning tile options will require the tile(s) to be removed during reconfiguration.
 - Spanning tackable fabric tiles are not possible due to the tile construction.

Panels & Trim

Beyond® — Working with Framed / Solid Panels & Trim

- For use in window sill application.
- Solid frame is standard, specify width up to face of sill.
- Solid tiles are engineered to order to overhang frame into sill, cut to fit in field. Engineered to order product request will include a set of two cuttable tiles, one for each side of the frame. Cuttable tiles are handed, maximum width is 60"W.
- Solid field cuttable tiles are wood, laminate, or painted.
- Recommend cuttable tiles not extend past frame more than 24". (Example: if solid cuttable tiles are 48"W, minimum solid frame is 24"W.)
- Specify solid window sill u-channel BY-FSSILLTRIM to finish off end of solid cuttable tiles. Trim is 120"L. Trim can be specified in stain anodized or painted finish.

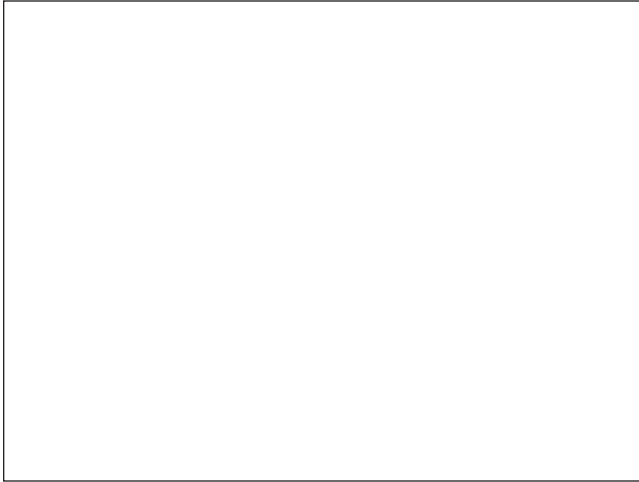

Solid window sill u-channel BY-FSSILLTRIM

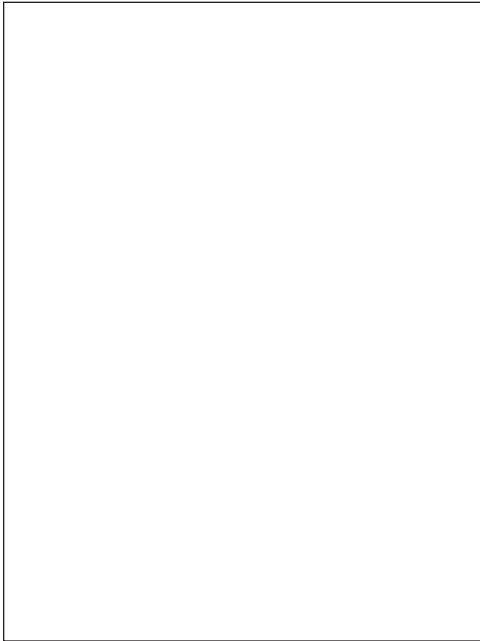

Engineered to order solid cuttable tile set

Stacking Panels

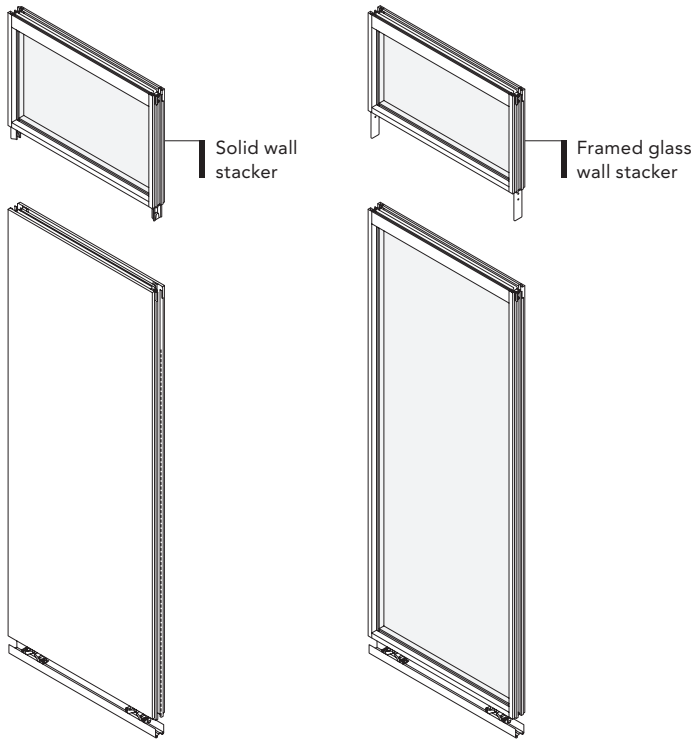

Stacking Glass on Solid Wall

Stacking Glass on Framed Glass

- Add a framed glass stacking panel ("stacker") to framed glass, solid panels, and doors to extend the total height up to a maximum of 144"H. Stackers are field installed to the base panel.
- Stacker Dimension Possibilities
 - Width
 - 8" - 60"W in 1/4" increments above a panel
 - 36" - 120"W in 1/4" increments above single or double doors and freeways; up to 58" in height
 - Limited by door frame or freeway module width and minimum height. The freeway or frame plus stacker cannot exceed 144"H.
 - Height
 - 9 1/2" - 120" in 1/4" increments above a panel
 - 10 1/2" - 36 1/8" in 1/4" increments above a panel with integrated mounting rail
 - Glass Thickness:
 - 1/4"
 - 3/8"
- Available on Framed and Solid.
- Specification Information:
 - Framed glass panels specified with a stacker must utilize uniform width vertical style on the frame. Stacking panel construction consists of a uniform width vertical style frame surrounding a pane of glass.
 - Solid panel tiles must be specified with reveal as tiles would need removed to install zippers if specified as butt-jointed. Tiles cannot be removed once stacker is installed.
 - Solid panel tiles must be specified with base trim as tiles would need removed to level panels if tiles specified to the floor. Tiles cannot be removed once stacker is installed.
 - Utilize stacking posts with stacking panels. Stacking posts will be butt-jointed with the post below at the stacking segment height
 - Specify an additional set of zippers for the stacking section.
 - Solid walls must be removed from the run if a monolithic tile or top tile needs to be removed from a panel with a stacking segment.
 - Stackers do not come pre-attached to framed or solid panel and must be field-installed.
 - Note that the base model for framed glass stackers BY-STILEGLASS is the same base model as integrated framed glass on solid panels.
- Seismic applications cannot exceed 120" in total height.

Panels & Trim

Beyond® — Working with Framed / Solid Panels & Trim

Framed and Solid Integrated Mounting Rail

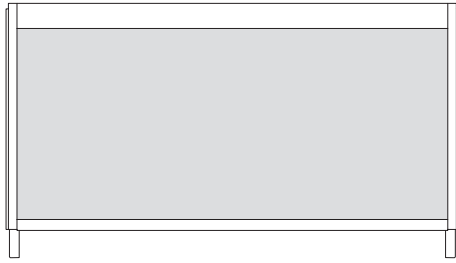

Framed glass with standard rail

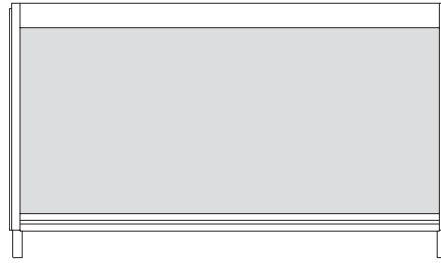

Framed glass with integrated mounting rail

Framed and solid panels can be specified with an integrated mounting rail horizontal bar. This integrated mounting rail can be used to attach a sliding door directly to the panels with a glass transom above. The sliding door is at a fixed height of 7ft. Order a sliding door frame with transom for this configuration. See [Beyond Doors for details](#). It can also allow for TV-mounting that doesn't deface the solid tiles, Stride off-modular connection (for panels up to 57½"), and accessory hooks. See [Furniture Integration](#) and [Technology Integration](#) for details.

Note that the integrated mounting rail horizontal bar is slightly taller than the standard horizontal bar.

Specification Details:

- The integrated mounting rail bar can be specified at 83⅞" AFF or higher on a framed or solid panel in ⅛" increments

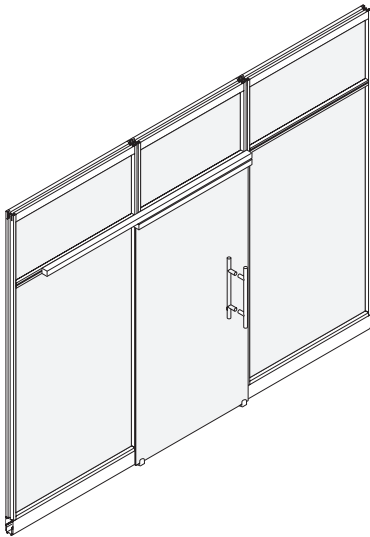

Sliding Frameless Glass with Transom

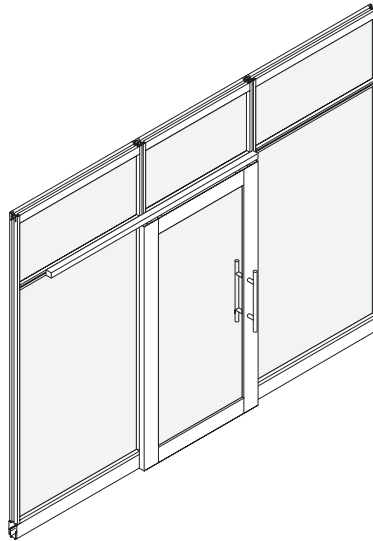

Sliding Aluminum Framed with Transom

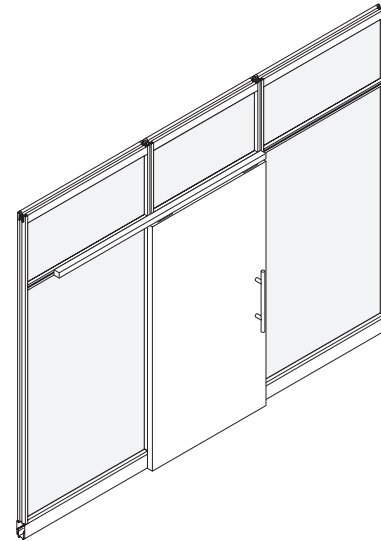

Sliding Solid with Transom

Base Trim

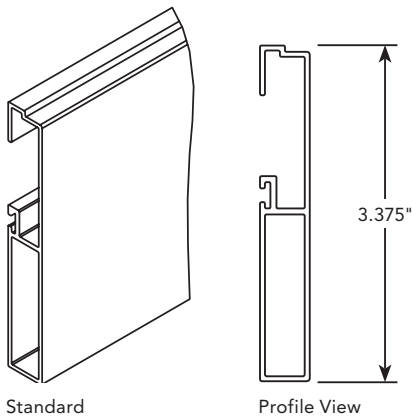

- Base trim connects to the base channel and is specified on both sides of a framed or solid panel.
- 3⁵/₈"H for trim itself.
- 4³/₁₆"H from finished floor to top of trim with nominal reveal of 3/4".
- Available in 96" or 120" lengths.
- CET adds 10% to standard height, non-ported base trim quantity for scrap.

Electrical Base Trim

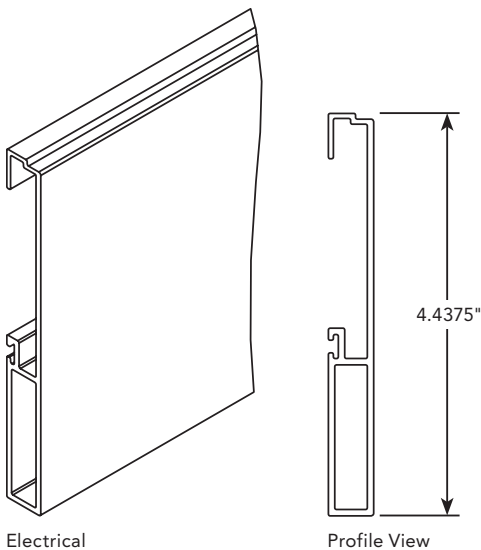

- Utilize the electrical base trim for projects with modular electrical in framed or solid panels. Base trim connects to the base channel and is specified on both sides of the panel. The electrical base trim is 1" taller than the standard, non-electrical trim.
- 4⁵/₈"H for trim itself.
- 5³/₁₆"H from finished floor to top of trim with nominal reveal of 3/4".
- Non-ported electrical base trim is available in 96" or 120" lengths.
- Framed and solid pre-ported base trim at 60¹/₂"W is available for single or double receptacles.
- Can be utilized on panels with minimum width of 45".
- Base trim that is 48¹/₂"W with QTY (2) additional data ports allows data to be placed to the right or left of the duplex receptacles. This is available for double receptacles only. Trim can be cut in the field so that one data port is removed if it's not used.
- Due to wall depth, back-to-back data modules should not be used. If required, it is recommended that extended data faceplates be used. Width is 48".
- All electrical and data ported trim for framed and solid panels comes with enhanced gasketing.
- CET adds 10% to electrical height non-ported base trim quantities for scrap.
 - CET adds 0% to electrical height ported base trim quantities for scrap.

Standard Zipper



Zipper

- Framed and solid panels are connected utilizing fast-installing co-polymer zippers. Zippers are used to connect framed panels to other framed panels and solid panels to other solid panels. Note that zippers are also used to connect frameless adapters to door frames or posts.
 - Standard zippers are 1/2"W and can flex up to 5 degrees. Standard zippers do not add dimension to the overall wall run.
 - Order single zippers or a bulk pack of QTY 75.
 - Once 41 zippers are reached, the specification program will automatically specify a bulk pack of 75 zippers.

Adjustable Angle Zipper

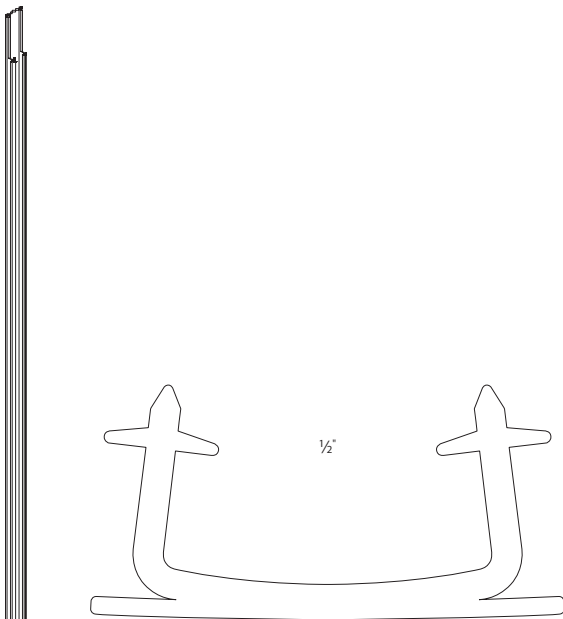

- Adjustable angle zippers are 1"W and can flex up to 15 degrees. The adjustable angle zipper planning dimension is 1/2"W due to the zipper adding 1/2" to the overall wall run.

Zipper Adjustment Capability:

Angled Zippers

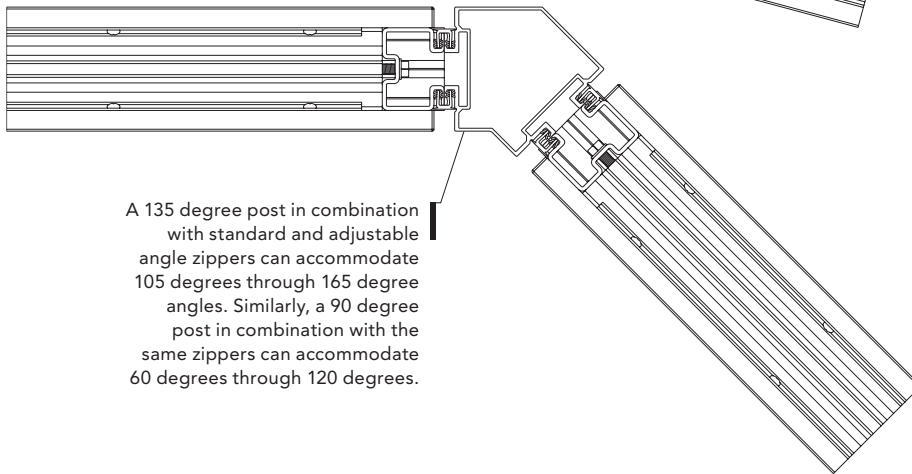
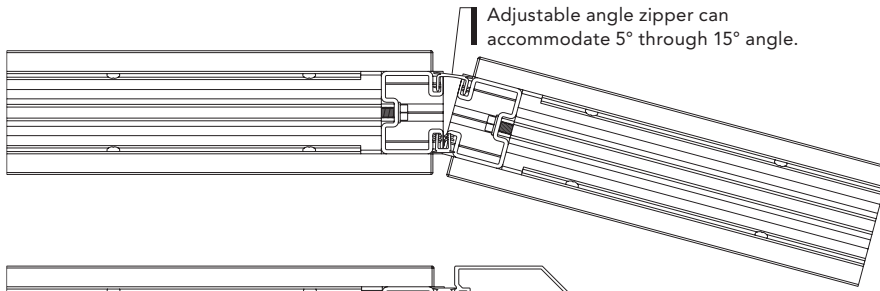
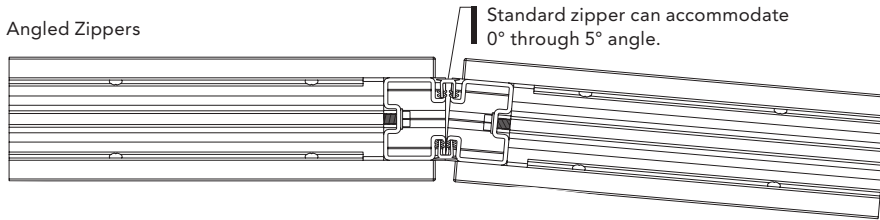

A 135 degree post in combination with standard and adjustable angle zippers can accommodate 105 degrees through 165 degree angles. Similarly, a 90 degree post in combination with the same zippers can accommodate 60 degrees through 120 degrees.

TV Mounting Guidelines for Solid Walls

There are multiple ways to mount a TV on Beyond solid wall product, including:

- Flush Mount
- Bracket Mount
- Variable Height TV Mounting Plate for use with bracket mount or flush mount brackets
- Integrated Mounting Rail Mount

See the following pages for details. Solid walls need to be ordered with electrical porting capability per the TV mount style to provide power access for the TV. Brackets are available for order. Other componentry must be submitted to Allsteel as an engineered-to-order (ETO) option.

Hard surface tiles are required where the TV is mounted. If segmenting the panel to limit the hard surface area to just behind the TV, it is critical to have the full dimensional details of the TV and the mount. These details will provide the needed information to ensure segment changes are hidden behind the TV and do not interfere with the internal structure of the panel.

Several of the TV mounting solutions utilize the TV mounting bracket (model BY-FGTVBRACKET, previously BYTVB) to provide the interface between the wall and the TV. Details are shown in each subsequent section.

The TV mounting bracket supports the following:

- 32"-70" flat panel displays up to 165 pounds
- 10 to 0 degree tilt
- VESA® mounting hole patterns
 - 200 x 200 mm
 - 300 x 300 mm
 - 400 x 200 mm
 - 400 x 400 mm
 - 600 x 400 mm

TV Integration

Model BY-FGTVBRACKET:

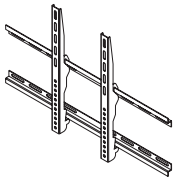

TV-Mount Bracket

Model BY-TVBRACKET:

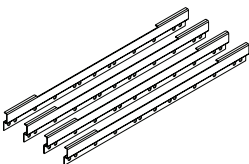

Flush-Mounted Bracket

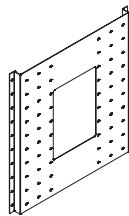

Variable-Height Mounting Bracket

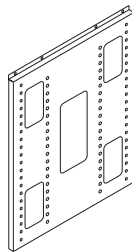

Integrated Mounting Rail Mounting Plate

Solid Wall Flush Mount TV Mounting

Flush mount TV mounting attaches the TV as close as possible to the solid wall so that the only dimension extending from the wall is the thickness of the TV and the minimal bracket thickness. This style of TV mount requires the brand and model number prior to order. Mounting patterns on the back of TVs are in different locations depending upon the brand. Once the pattern location and desired height of the TV is determined, the solid wall will be designed to the specifications. A single junction box is mounted inside the wall cavity to provide a power chase to the TV. Conduit from the junction box is ½" trade size flex conduit. Wiring to be performed by a licensed electrician.

The following information is required as part of the engineered-to-order (ETO) panel request:

- Make and model of TV
- Mounting height to the vertical centerline of the TV AFF
- Mounting centerline location horizontally (location for centered, offset, spanning, etc.)
- Required electrical, cabling, and data needs, including conduit routing direction

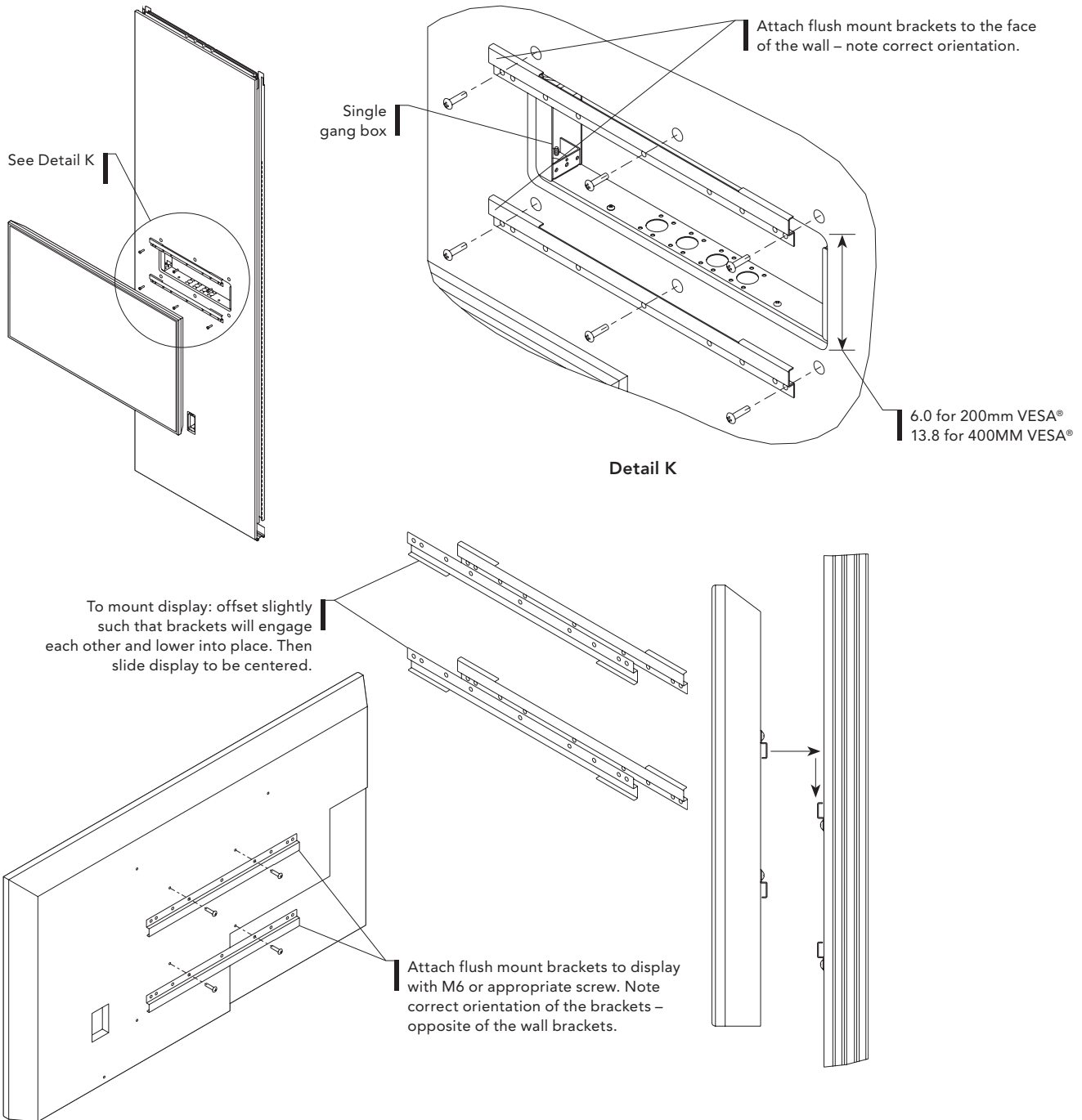

Solid Wall Bracket Mount TV Mounting

Bracket mount TV mounting attaches the TV to the solid wall utilizing a bracket to interface between the two. Mounting patterns on the back of TVs are in different locations depending upon the brand. Once the pattern location and desired height of the TV is determined, the solid wall will be designed to the specifications. The junction box size and location can be customized and will provide a power chase to the TV. Conduit from the junction box is 1/2" trade size flex conduit. Wiring to be performed by a licensed electrician.

The following information is required as part of the engineered-to-order (ETO) panel request:

- Make and model of TV
- Brand and detailed information of TV mount if not using the standard model
- Mounting height to the vertical centerline of the TV AFF
- Mounting centerline location horizontally (location for centered, offset, spanning, etc.)
- Required electrical, cabling, and data needs, including conduit routing direction
- The bracket itself is a standard component.
- An engineered-to-order (ETO) hard surface tile is required with coordinating ports for j-box(es).

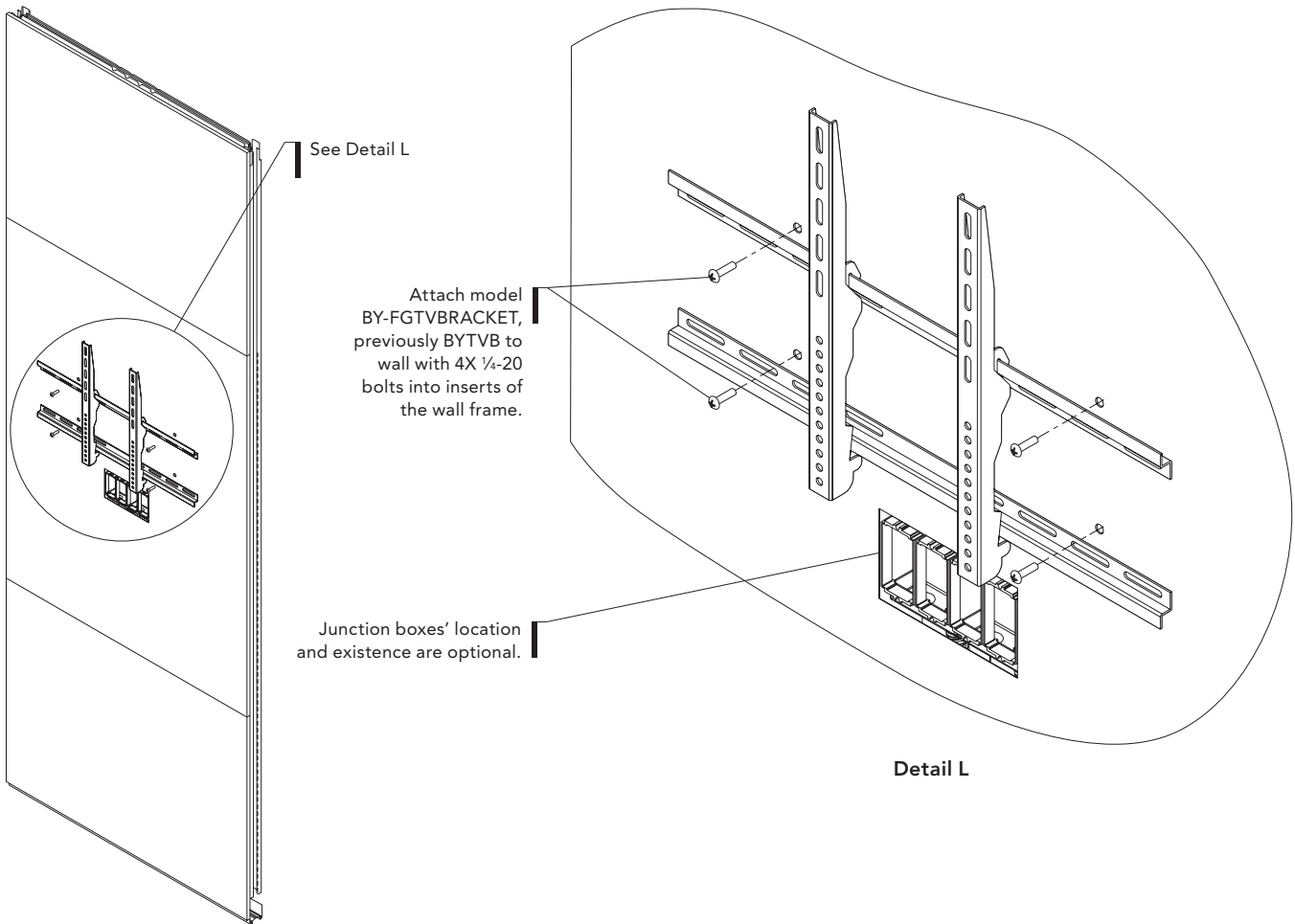

BEYOND TABLE OF CONTENTS
 BEYOND FINISHES & FABRICS
 BEYOND PANELS & TRIM
 BEYOND DOORS
 BEYOND CONNECTORS
 BEYOND ELECTRICAL & DATA
 BEYOND FRAMELESS PRIVACY TILE SYSTEM
 BEYOND VIZ

Solid Wall TV Mount with Variable Height TV Mounting Plate

The variable height TV mount provides the most flexibility when mounting TVs and is recommended when the brand and model of the TV have not yet been selected. The mounting plate is to be located at the approximate centerline of the TV. The mounting plate has a set of holes on the 16" horizontal centerline to match the stud centerline used on most TV mounts. The holes are spaced 50mm or approximately 2" apart vertically to allow movement of the TV mount up and down. This hole pattern allows the attachment of the flush mount bracket or the TV mounting bracket. These brackets then create the interface from the TV to the mounting plate.

The following information is required as part of the engineered-to-order (ETO) panel request:

- Mounting height to the vertical centerline of the TV AFF
- Mounting centerline location horizontally (location for centered, offset, spanning, etc.)
- Required electrical, cabling, and data needs, including conduit routing direction
- A standard model BY-FGTVBRACKET, previously BYTVB, mounting bracket or flush mount bracket is required in addition to the custom panel.
- An engineered-to-order (ETO) hard surface tile is required with coordinating ports for j-box(es) and holes for the mounting plate.

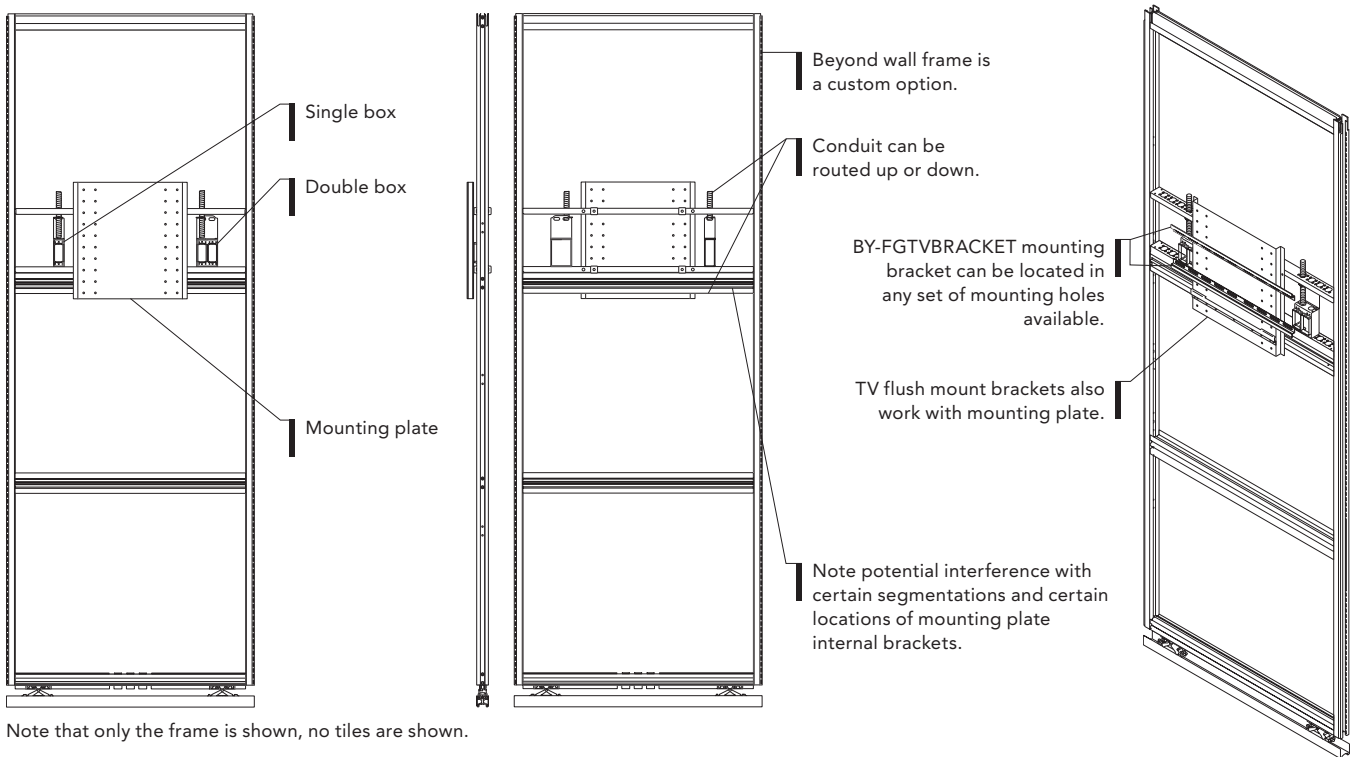

Solid Wall Integrated Mounting Rail TV Mount

The integrated mounting rail TV mount utilizes the integrated mounting rail clerestory to support the TV. The TV mounting plate ties into the integrated mounting rail of the clerestory and allows the TV to be moved from side to side as desired. A TV bracket (model BY-FGTVBRACKET) is then used to provide the interface between the mounting plate and the TV. It is recommended to utilize the "with reveal" option along with the wire manager (model BFSWMB) to provide cable management down to the standard receptacle locations in the panel. Optional posts are available to route power up to the TV height location. The plate provides cutouts for access. Engineered-to-order (ETO) electrical locations may also be requested.

Electrical, cabling, and data needs are required.

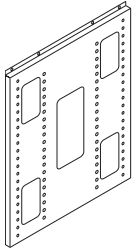

Integrated Mounting Rail TV Mounting Plate

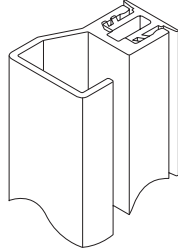

Wire Manager

See page 189 for specification data

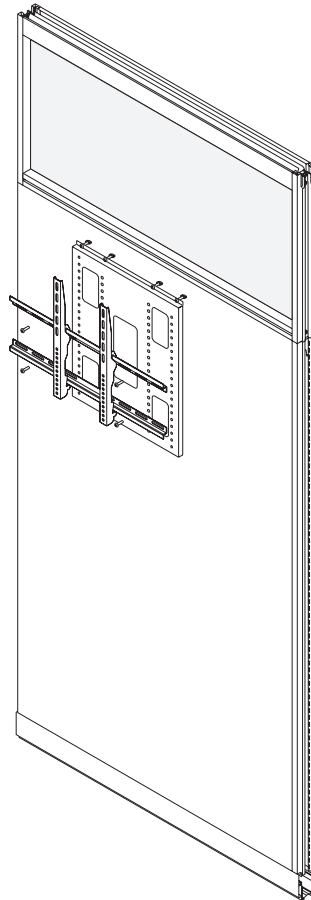
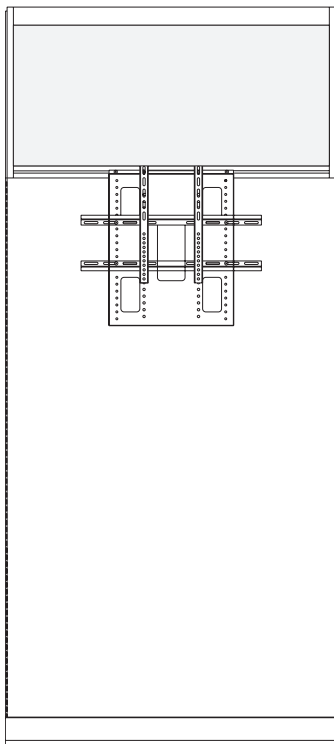

Attach sheet metal mounting plate with M6 bolt and z-nut.

Attach mounting bracket with hardware from BY-FGTVBRACKET model.

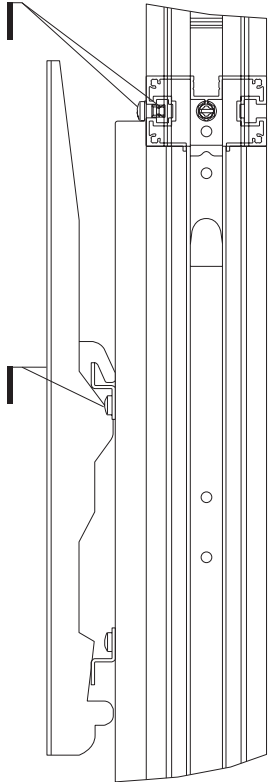

BEYOND TABLE OF CONTENTS
BEYOND FINISHES & FABRICS
BEYOND PANELS & TRIM
BEYOND DOORS
BEYOND CONNECTORS
BEYOND ELECTRICAL & DATA
BEYOND FRAMELESS PRIVACY TILE SYSTEM
BEYOND VIZ

Vertical Furniture Integration



Hanging Bracket

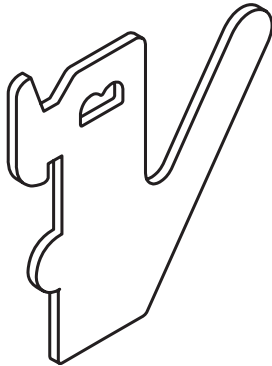

Accessory Hook

- All solid wall frames ship with slotted standards in the vertical reveal to provide furniture-mounting capability. Vertical furniture mounting brackets must be specified to connect furniture components to the slotted standards in the solid wall frame.
 - Utilize Stride®/Terrace® furniture and components for vertical furniture integration.
 - The half-inch reveal option must be specified to allow for furniture mounting utilizing the vertical slotted standards.
 - Integration of furniture components meets applicable systems BIFMA 5.6 requirements.
 - Available in three sizes:
 - Worksurface bracket 3"H.
 - Small 8"H (niche mounting).
 - Large 11"H (overhead and cantilever mounting).
 - Accessory hooks are available to connect into the slotted standards adjacent to the zipper to provide a hook for picture mounting, coats, and accessories. Accessory hooks are a pack of quantity six.
 - Wood overheads and niches can be mounted to a Beyond panel of equal width for a modular design. An example is a 48"W overhead mounted to a 48"W Beyond panel.
 - Approach overheads can mount off module.
 - Metal overheads can be mounted on a Beyond panel of equal width or up to 18" narrower than the overhead when using an off-module kit. One side of the overhead must be mounted on module. An example of this is a 48"W overhead mounted to a 30"W Beyond panel.
 - Furniture can be positioned vertically on the panel in 1" increments.
 - Other manufacturers' furniture components may be capable of mounting to Beyond utilizing a custom adapter bracket. A sample of the furniture components to be mounted must be sent to Allsteel for the Tailored Products Group to review.
 - Brackets come in painted finishes. Specify Anodized Silver - PR0 to coordinate with Clear, Anodized frame.

Vertical Furniture Integration

Example of Vertical Furniture Integration:

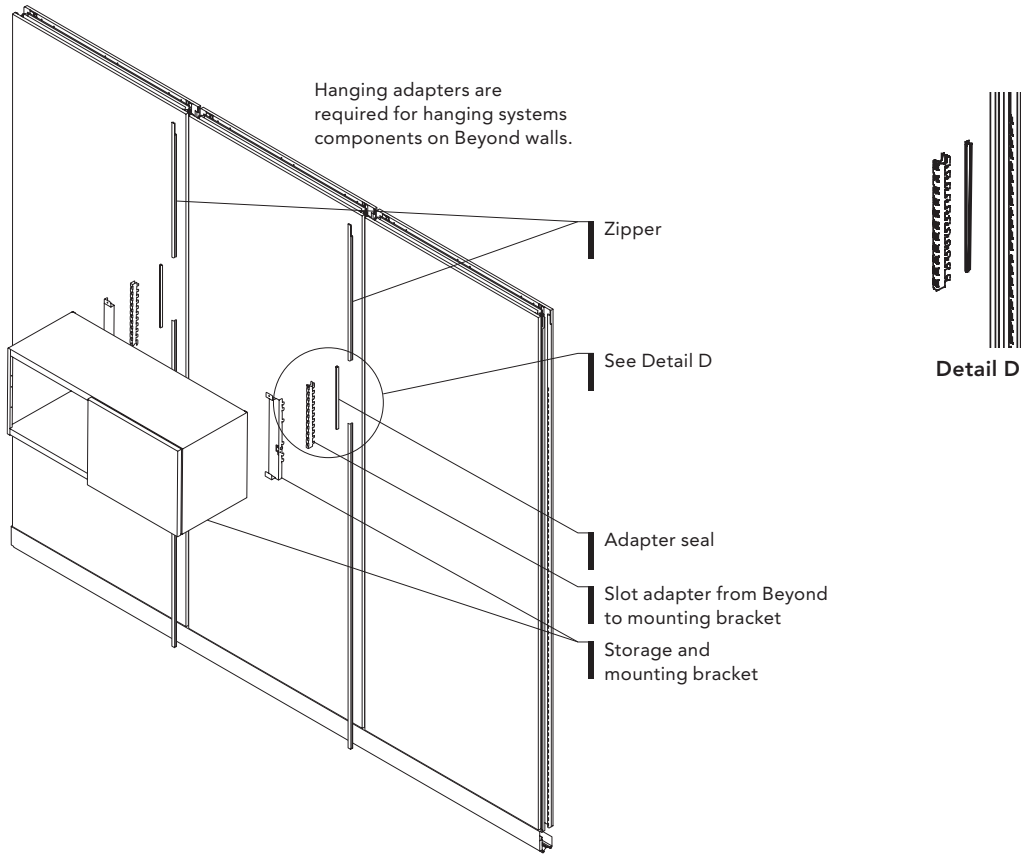

Off-Modular Adapter Stride® to Beyond – Integrated Mounting Rail

- Off-modular adapter utilizes the integrated mounting rail for framed glass or the integrated mounting rail clerestory for solid wall to connect the adapter.
- Designed for use with 30"H Stride® panels. Adapters to support additional heights available as an engineered-to-order (ETO) model.
- Allows limited routing of data cables.

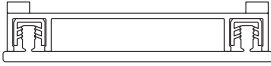

Off-Modular Adapter, Stride® to Beyond – Integrated Mounting Rail

Example of Off-Modular Adapter Assembly:

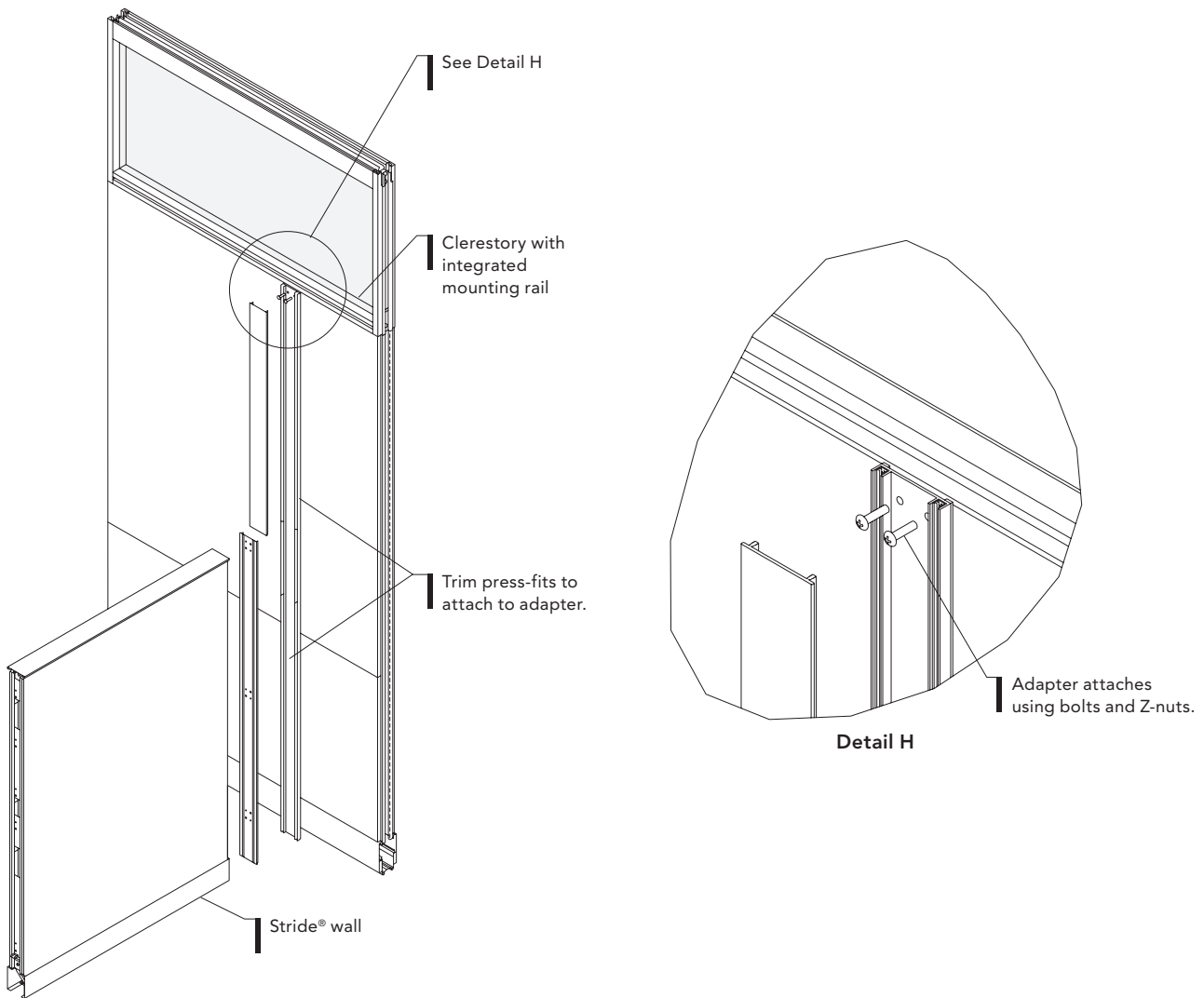

Panels & Trim

Top Anchors

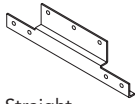

Straight

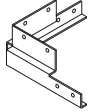

Two-Way

Floor Anchors

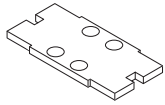

Straight

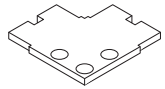

Two-Way

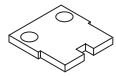

Finished End

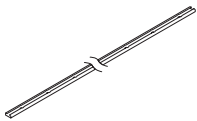

Full View

Base Model	Description	Specification
BY-FGANCHOR	Frameless Seismic Anchor	BY-FGANCHOR

Option	Specification Description	Specification
Anchor Type	Top Anchor - Straight	AS
	Top Anchor - Two-Way	AT
	Floor Anchor - Straight	FS
	Floor Anchor - Two-Way	FT
	Floor Anchor - Finished End	FE

Specification Example: **BY-FGANCHOR.AS**

Base Model	Description	Specification
BY-FSANCHOR	Framed/Solid Seismic Anchor	BY-FSANCHOR

Specification Example: **BY-FSANCHOR**

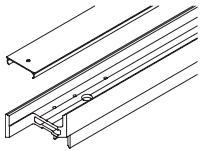
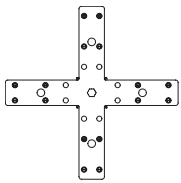
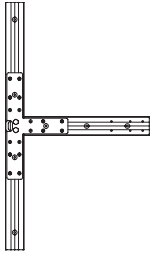
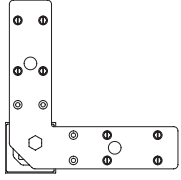

Base Model	Description	Specification
BY-PLATE	Freestanding Post Flat Bracket	BY-PLATE
Configuration ID	Specification Description	
Product	Beyond Freestanding	
Nominal Length	Varies, depending on bracket selection	
Trim Type	Freestanding Bracket	
Trim Use	Two Way, Three Way, or Four Way	

Specification Example: **BY-PLATE.####**

Base Model	Description	Specification
BY-FSCORNICE	Freestanding Cornice	BY-FSCORNICE
Configuration ID	Specification Description	
Product	Beyond Freestanding	
Dimension	120"W	
Trim Type	Cornice	
Trim Use	Cornice Without Snap-On Trim Cornice With Snap-On Trim Cornice Without Snap-On Trim, With Building Interface Cornice With Snap-On Trim and Building Interface	
Trim Style	Will populate if Snap-On Trim is selected Low Profile (Low Profile = Snap-On Trim)	
Finish Color	Painted or Anodized Finishes	

Option	Specification Description	Specification
Frame Finish	3-digit painted or anodized finish	See Beyond Frame Finishes

Specification Example: **BY-FSCORNICE.####.P8X**

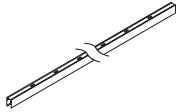

Ceiling Channel

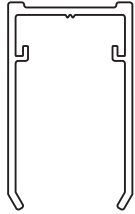

Ceiling Channel:
Profile View

Base Model	Description	Specification
BY-CCHANNEL	Ceiling Channel	BY-CCHANNEL
Configuration ID	Specification Description	Specification
Product	Beyond	
Dimension	120"	
Trim Type	Ceiling Channel	
Trim Use	Universal	
Finish Color	Painted or Anodized Finishes	
Option	Specification Description	Specification
Paint Color Selection	3-digit painted or anodized finish	See Beyond Frame Finishes

Specification Example: **BY-CCHANNEL.####.P8X**

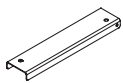

Straight

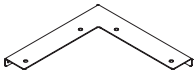

Two-Way

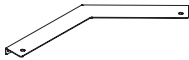

135-Degree

Base Model	Description	Specification
BY-CSPLICE	Ceiling Channel Splice	BY-CSPLICE
Option	Specification Description	Specification
Splice Type	Straight	CS
	Two-Way	CT
	135-Degree	C135

Specification Example: **BY-CSPLICE.CS**

Panels & Trim

Beyond® — Ceiling Grid Clips & Tegular Spacers



1/8 T-Bar Clip



1 5/16 T-Bar Clip



T Bolt

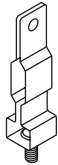

1/8 Fineline Clip

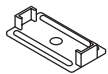

Tegular Spacer

Base Model	Description	Specification
BY-CCLIP	Ceiling Grid Clip	BY-CCLIP
Option	Specification Description	Specification
Clip Type and Quantity	1/8 T-Bar Clip QTY 10 QTY 100	916TBC 10 100
	1 5/16 T-Bar Clip QTY 10 QTY 100	1516TBC 10 100
	T Bolt QTY 10 QTY 100	TBOLT 10 100
	1/8 Fineline Clip QTY 10 QTY 100	916FC 10 100

Specification Example: **BY-CCLIP.916TBC10**

Base Model	Description	Specification
BY-CTEGSPACER	Ceiling Grid Tegular Spacer	BY-CTEGSPACER
Option	Specification Description	Specification
Quantity	Tegular Spacer QTY 10 QTY 100	TSPACER 10 100

Specification Example: **BY-CTEGSPACER.TSPACER10**



Tempered Glass



Tempered Glass with Single Perforations



Laminated Glass

Base Model	Description	Specification
BY-FRMLSTPANEL	Frameless Glass Panel, Tempered	BY-FRMLSTPANEL
Configuration ID	Specification Description	
Product	Beyond	
Width	8"-42" up to 120"H in ¼" increments 42¼"-48" up to 108"H in ¼" increments	
Height	18"-120" In ¼" increments.	
Glass Code	HA: ½" Tempered, Clear HB: ½" Tempered, Low Iron	
Perforation Pattern	Will populate if selecting perforated glass: 1S, Single Perforations: Single or Double to the Base 1D, Double Perforations: Single or Double to the Base 2S, Single Perforations: Double Floating, Triple to the Base, Markerboard or Triple to the Base with Markerboard 2D, Double Perforations: Double Floating, Triple to the Base, Markerboard or Triple to the Base with Markerboard 3S, Single Perforations: Single with Modesty 3D, Double Perforations: Single with Modesty 4S, Single Perforations: Double with Modesty or Markerboard with Modesty 4D, Double Perforations: Double with Modesty or Markerboard with Modesty 5S, Single Perforations: Button Mount 5D, Double Perforations: Button Mount 6S, Single Perforations: Visual Distraction Markers at 54.67" AFF nominal 6D, Double Perforations: Visual Distraction Markers at 54.67" AFF nominal 7S, Single Perforations: TV Mount Height and TV Mount Height with Markerboard 7D, Double Perforations: TV Mount Height and TV Mount Height with Markerboard	

Specification Example: **BY-FRMLSTPANEL.#####**

Base Model	Description	Specification
BY-FRMLSLPANEL	Frameless Glass Panel, Laminated	BY-FRMLSLPANEL
Configuration ID	Specification Description	
Product	Beyond	
Width	8-42" up to 120"H in ¼" increments 42¼"-48" up to 108"H in ¼" increments	
Height	18"-120" In ¼" increments. See specification rules for details	
Glass code	HC: ½" Laminated, Clear HD: ½" Laminated, Low Iron HG: ½" Laminated, High Performance, Clear HH: ½" Laminated, High Performance, Low Iron	

Specification Example: **BY-FRMLSLPANEL.####**

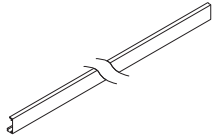

Straight



Profile View

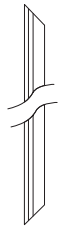

Inside Corner Top View



Outside Corner Top View

Base Model	Description	Specification
BY-FGCTRIM	Frameless Ceiling Trim	BY-FGCTRIM

Configuration ID	Specification Description
Product	Beyond
Product Type	Frameless Anodized Frameless Painted
Dimension	120" - Straight Trim 96" - Inside/Outside Corner Trim
Trim Type	Top
Trim Use	Straight Inside Corner Outside Corner
Finish Color	Painted or Anodized Finishes

Option	Specification Description	Specification
Paint Color Selection	3-digit painted or anodized finish	See Beyond Frame Finishes

Option	Specification Description	Specification
Paint Color Selection	3-digit painted or anodized finish	See Beyond Frame Finishes

Specification Example: BY-FGCTRIM.####.P8X

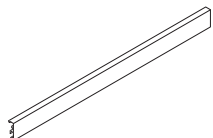

Straight



Profile View

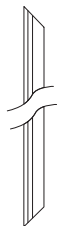

Inside Corner Top View

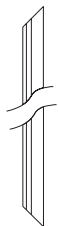

Outside Corner Top View

Base Model	Description	Specification
BY-FGSBTRIM	Frameless Standard Base Trim	BY-FGSBTRIM

Configuration ID	Specification Description
Product	Beyond
Product Type	Frameless Anodized Frameless Painted
Dimension	120" - Straight Trim 96" - Inside/Outside Corner Trim
Trim Type	Base
Trim Use	Straight Non Ported Inside Corner Outside Corner
Trim Style	Standard
Finish Color	Painted or Anodized Finishes

Option	Specification Description	Specification
Paint Color Selection	3-digit painted or anodized finish	See Beyond Frame Finishes

Option	Specification Description	Specification
Paint Color Selection	3-digit painted or anodized finish	See Beyond Frame Finishes

Specification Example: BY-FGSBTRIM.####.P8X

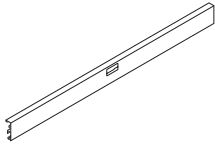

Single Receptacle

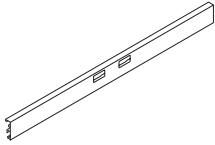

Double Receptacle

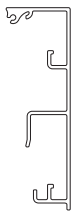

Profile View

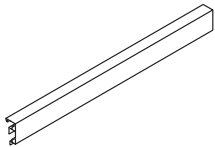

Straight

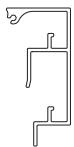

Profile View



Inside
Corner
Top View



Outside
Corner
Top View

Base Model	Description	Specification
BY-FGEBTRIM	Frameless Electrical Base Trim	BY-FGEBTRIM

Configuration ID	Specification Description
Product	Beyond
Product Type	Frameless Anodized Frameless Painted
Dimension	48"
Trim Type	Base
Trim Use	Straight Ported
Trim Style	Standard
Port Type	Single Port Double Port
Finish Color	Painted or Anodized Finishes

Option	Specification Description	Specification
Paint Color Selection	3-digit painted or anodized finish	See Beyond Frame Finishes

Specification Example: **BY-FGEBTRIM.####.P8X**

Base Model	Description	Specification
BY-FGLBTRIM	Frameless Low Profile Base Trim	BY-FGLBTRIM

Configuration ID	Specification Description
Product	Beyond
Product Type	Frameless Anodized Frameless Painted
Dimension	120" - Straight Trim 96" - Inside/Outside Corner Trim
Trim Type	Base
Trim Use	Straight Non Ported Inside Corner Outside Corner
Trim Style	Low Profile
Finish Color	Painted or Anodized Finishes

Option	Specification Description	Specification
Paint Color Selection	3-digit painted or anodized finish	See Beyond Frame Finishes

Specification Example: **BY-FGLBTRIM.####.P8X**

Option	Specification Description	Specification
Paint Color Selection	3-digit painted or anodized finish	See Beyond Frame Finishes

Option	Specification Description	Specification
Paint Color Selection	3-digit painted or anodized finish	See Beyond Frame Finishes

Option	Specification Description	Specification
Paint Color Selection	3-digit painted or anodized finish	See Beyond Frame Finishes

Option	Specification Description	Specification
Paint Color Selection	3-digit painted or anodized finish	See Beyond Frame Finishes

Option	Specification Description	Specification
Paint Color Selection	3-digit painted or anodized finish	See Beyond Frame Finishes

Option	Specification Description	Specification
Paint Color Selection	3-digit painted or anodized finish	See Beyond Frame Finishes

Option	Specification Description	Specification
Paint Color Selection	3-digit painted or anodized finish	See Beyond Frame Finishes

Option	Specification Description	Specification
Paint Color Selection	3-digit painted or anodized finish	See Beyond Frame Finishes

Option	Specification Description	Specification
Paint Color Selection	3-digit painted or anodized finish	See Beyond Frame Finishes

Option	Specification Description	Specification
Paint Color Selection	3-digit painted or anodized finish	See Beyond Frame Finishes

Option	Specification Description	Specification
Paint Color Selection	3-digit painted or anodized finish	See Beyond Frame Finishes

Option	Specification Description	Specification
Paint Color Selection	3-digit painted or anodized finish	See Beyond Frame Finishes

Option	Specification Description	Specification
Paint Color Selection	3-digit painted or anodized finish	See Beyond Frame Finishes

Option	Specification Description	Specification
Paint Color Selection	3-digit painted or anodized finish	See Beyond Frame Finishes

Option	Specification Description	Specification
Paint Color Selection	3-digit painted or anodized finish	See Beyond Frame Finishes

Option	Specification Description	Specification
Paint Color Selection	3-digit painted or anodized finish	See Beyond Frame Finishes

Option	Specification Description	Specification
Paint Color Selection	3-digit painted or anodized finish	See Beyond Frame Finishes

Option	Specification Description	Specification
Paint Color Selection	3-digit painted or anodized finish	See Beyond Frame Finishes

Option	Specification Description	Specification
Paint Color Selection	3-digit painted or anodized finish	See Beyond Frame Finishes

Option	Specification Description	Specification
Paint Color Selection	3-digit painted or anodized finish	See Beyond Frame Finishes

Option	Specification Description	Specification
Paint Color Selection	3-digit painted or anodized finish	See Beyond Frame Finishes

Option	Specification Description	Specification
Paint Color Selection	3-digit painted or anodized finish	See Beyond Frame Finishes

Option	Specification Description	Specification
Paint Color Selection	3-digit painted or anodized finish	See Beyond Frame Finishes

Option	Specification Description	Specification
Paint Color Selection	3-digit painted or anodized finish	See Beyond Frame Finishes

Option	Specification Description	Specification
Paint Color Selection	3-digit painted or anodized finish	See Beyond Frame Finishes

Panels & Trim

Beyond® — Trim Keys & Vertical Fillers

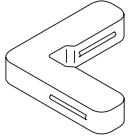

Corner Key

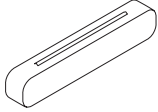

Straight Key

Base Model	Description	Specification
BY-FGTKEYS	Frameless Trim Keys	BY-FGTKEYS

Option	Specification Description	Specification
Key Type and Quantity	Straight Trim Keys QTY 50 QTY 250	S 50 250
	Corner Trim Keys QTY 50 QTY 250	L 50 250

Specification Example: **BY-FGBTKEYS.S50**

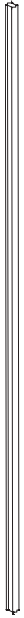

Base Model	Description	Specification
BY-FGFILLER	Frameless Vertical Filler	BY-FGFILLER

Configuration ID	Specification Description	Specification
Product	Beyond	
Dimension	120"	
Trim Type	Vertical Filler	
Trim Use	Straight Two Way Three Way Four Way Angle 135	
Trim Style	Clear Polycarbonate Anodized Aluminum	CPC SAL
Finish Color	See below	

Option	Specification Description	Specification
Vertical Fillers	Clear Polycarbonate Clear Anodized Aluminum	CPC SAL

Specification Example: **BY-FGFILLER.####.CPC**



Base Model	Description	Specification
BY-FRMDPANEL	Framed Glass Panel	BY-FRMDPANEL
Configuration ID	Specification Description	
Vertical Style	Uniform Narrow	
Enhanced Acoustic	Standard Enhanced	
Width	8"-60" in 1/4" increments. See specification for details	
Height	18"-120" for standard or electrical base 86"-120" for freestanding applications	
Glass Lites	1-6	
Glass Code 1	QA: 1/4" Tempered, Clear QB: 1/4" Tempered, Low Iron QC: 1/4" Laminated, Clear QD: 1/4" Laminated, Low Iron QE: 1/4" Laminated, Clear, Translucent White QF: 1/4" Laminated, Low Iron, Markerboard QG: 1/4" Laminated, High Performance, Clear QH: 1/4" Laminated, High Performance, Low Iron QL: 1/4" Laminated, Clear, Markerboard TA: 3/8" Tempered, Clear TB: 3/8" Tempered, Low Iron TC: 3/8" Laminated, Clear TD: 3/8" Laminated, Low Iron TE: 3/8" Laminated, Clear, Translucent White TF: 3/8" Laminated, Low Iron, Markerboard TG: 3/8" Laminated, High Performance, Clear TH: 3/8" Laminated, High Performance, Low Iron TL: 3/8" Laminated, Clear, Markerboard TN: 3/8" Back-to-Back Back-Painted, Low Iron, Turquoise TP: 3/8" Back-to-Back Back-Painted, Low Iron, Cherry TQ: 3/8" Back-to-Back Back-Painted, Low Iron, Lawn TR: 3/8" Back-to-Back Back-Painted, Low Iron, Jet TS: 3/8" Back-to-Back Back-Painted, Low Iron, Mandarin	
Glass Codes 2-6	If there are additional glass lites, these will populate. Glass Finish options are the same as for Glass Code 1.	
Segment 1 Type	Standard Integrated Mounting Rail	
Segment 1 AFF to Top	11 3/16" and up in 1/16" increments. See specification rules for details	
Segment 2-5 Type	If there are additional segments, these will populate. Options are the same as segment 1.	
Segment 2-5 AFF to Top	If there are additional segments, these will populate. See specification rules for details	
Base Style	Standard Integrated Mounting Rail	
Frame Finish	See Beyond Frame Finishes	

Specification Example: BY-FRMDPANEL.#####

Base Model	Description	Specification
BY-FRMDSEALPKG	Framed Glass Panel Seal Retrofit	BY-FRMDSEALPKG

BEYOND TABLE OF CONTENTS BEYOND FINISHES & FABRICS BEYOND PANELS & TRIM BEYOND DOORS BEYOND CONNECTORS BEYOND ELECTRICAL & DATA BEYOND FRAMELESS PRIVACY TILE SYSTEM BEYOND VIZ

Panels & Trim

Beyond® — Framed Wood Slat Infill Panels

Base Model	Description	Specification
ETO-AP-BY-WSLAT96	Beyond Framed Wood Slat Infill Panel - 96"H	ETO-AP-BY-WSLAT96
Option	Specification Description	Specification
Special Number	XBMN-9432	M516807
Width	24"W	2400W
	30"W	3000W
	36"W	3600W
	42"W	4200W
	48"W	4800W
Base Style	Standard	S
	Electrical	E
FSC Option	FSC Certified	FSC
	Standard Wood	X
Wood Selection	See Beyond Wood Slat Finishes	
Trim Color Selection	Anodized, Clear	SAL
	Painted - See Beyond frame finishes	---

Specification Example: ETO-AP-BY-WSLAT96.M516807.2400W.S.FSC.AH400.SAL

Base Model	Description	Specification
ETO-AP-BY-WSLAT102	Beyond Framed Wood Slat Infill Panel - 102"H	ETO-AP-BY-WSLAT102
Option	Specification Description	Specification
Special Number	XBMN-9433	M516808
Width	24"W	2400W
	30"W	3000W
	36"W	3600W
	42"W	4200W
	48"W	4800W
Base Style	Standard	S
	Electrical	E
FSC Option	FSC Certified	FSC
	Standard Wood	X
Wood Selection	See Beyond Wood Slat Finishes	
Trim Color Selection	Anodized, Clear	SAL
	Painted - See Beyond frame finishes	---

Specification Example: ETO-AP-BY-WSLAT102.M516808.2400W.S.FSC.AH400.SAL

Base Model	Description	Specification
ETO-AP-BY-WSLAT108	Beyond Framed Wood Slat Infill Panel - 108"H	ETO-AP-BY-WSLAT108
Option	Specification Description	Specification
Special Number	XBMN-9434	M516809
Width	24"W	2400W
	30"W	3000W
	36"W	3600W
	42"W	4200W
	48"W	4800W
Base Style	Standard	S
	Electrical	E
FSC Option	FSC Certified	FSC
	Standard Wood	X
Wood Selection	See Beyond Wood Slat Finishes	
Trim Color Selection	Anodized, Clear	SAL
	Painted - See Beyond frame finishes	---

Specification Example: ETO-AP-BY-WSLAT108.M516809.2400W.S.FSC.AH400.SAL

Base Model	Description	Specification
ETO-AP-BY-WSLAT114	Beyond Framed Wood Slat Infill Panel - 114"H	ETO-AP-BY-WSLAT114

Option	Specification Description	Specification
Special Number	XBMN-9435	M516810
Width	24"W	2400W
	30"W	3000W
	36"W	3600W
	42"W	4200W
	48"W	4800W
Base Style	Standard	S
	Electrical	E
FSC Option	FSC Certified	FSC
	Standard Wood	X
Wood Selection	See Beyond Wood Slat Finishes	
Trim Color Selection	Anodized, Clear	SAL
	Painted - See Beyond frame finishes	---

Specification Example: ETO-AP-BY-WSLAT114.M516810.2400W.S.FSC.AH400.SAL

Base Model	Description	Specification
ETO-AP-BY-WSLAT120	Beyond Framed Wood Slat Infill Panel - 120"H	ETO-AP-BY-WSLAT120

Option	Specification Description	Specification
Special Number	XBMN-9436	M516811
Width	24"W	2400W
	30"W	3000W
	36"W	3600W
	42"W	4200W
	48"W	4800W
Base Style	Standard	S
	Electrical	E
FSC Option	FSC Certified	FSC
	Standard Wood	X
Wood Selection	See Beyond Wood Slat Finishes	
Trim Color Selection	Anodized, Clear	SAL
	Painted - See Beyond frame finishes	---

Specification Example: ETO-AP-BY-WSLAT120.M516811.2400W.S.FSC.AH400.SAL

BEYOND TABLE OF CONTENTS
BEYOND FINISHES & FABRICS
BEYOND PANELS & TRIM
BEYOND DOORS
BEYOND CONNECTORS
BEYOND ELECTRICAL & DATA
BEYOND FRAMELESS PRIVACY TILE SYSTEM
BEYOND VIZ



Base Model	Description	Specification
BY-SLDPANEL	Solid Panel Assembly	BY-SLDPANEL
Configuration ID	Specification Description	
Solid Panel Frame	BY-SLDPNLFRAME. Note: model logic details for BY-SLDPNLFRAME and other models listed below will display in specification program; however base models themselves will NOT show up in specification program when BY-SLDPANEL is expanded out.	
Solid Panel Tiles	BY-STILESTEEL BY-STILEFAB BY-STILEVEN BY-STILELAM BYSTILEGLASSMB BY-STILESTEELMB BY-STILEGLASS BY-SPTILESTEEL BY-SPTILEFAB BY-SPTILEVEN BY-SPTILELAM	

Specification Example: **BY-SLDPANEL.#####**

Note: Spanning tiles must be field-installed.

Base Model	Description	Specification
BY-SLDSEALPKG	Solid Panel Seal Retrofit	BY-SLDSEALPKG

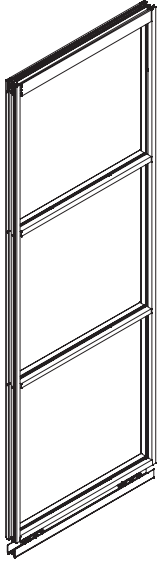

Base Model	Description	Specification
BY-SLDPNLFRAME	Solid Panel Frame	BY-SLDPNLFRAME
Configuration ID	Specification Description	
Width	8"-60" in ¼" increments. See specification for details	
Height	18"-120" in ¼" increments for standard or electrical base. See specification for details 86"-120" for freestanding applications	
Segment Quantity	1-8. Note: this refers to segment bars. With 8 segment bars, a panel will have 9 tiles.	
Segment 1 AFF to CL	See specification rules for details	
Segment 2-8 AFF to CL	If there are additional segments, these will populate. See specification rules for details	
Insulation	Yes No	
Base Style	Standard Electrical	
Frame Finish	Painted or Anodized Finish	
1st Electrical Segment	1	
1st Electrical Type	Quad	
1st Electrical Location	Panel Side Side A Side B Horizontal J-Box Placement Left Center Right Vertical J-Box Placement Above Segment Below Segment	
2nd-4th Electrical Segment	If there are additional electrical options, these will populate	
2nd-4th Electrical Type	If there are additional electrical options, these will populate. Options are the same as 1st Electrical Type	
2nd-4th Electrical Location	If there are additional electrical options, these will populate. Options are the same as 1st Electrical Location	
Conduit Direction	Up Down	
Option	Specification Description	Specification
Paint Color Selection	3-digit painted or anodized finish	See Beyond Frame Finishes

Specification Example: BY-SLDPNLFRAME.####.P8X

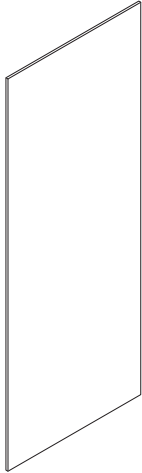

Painted Steel Tile

Base Model	Description	Specification
BY-STILESTEEL	Painted Steel Tile, Non-Ported	BY-STILESTEEL
Configuration ID	Specification Description	
Top Mounting	Field will populate if field-installed: Standard Top	
Enhanced Acoustic	Standard Enhanced	
Tile Type	Steel	
Width	8" -60" in ¼" increments	
Height	6½" - 118½" in ⅙" increments	
Assembly Type	Field will populate if field-installed: Field Installed	
Reveal Type	Butt Joint Half Inch	
Tile Base	Standard Standard Base, Tile to the Floor Electrical Base, Tile to the Floor	
Paint Finish	See Beyond Painted Steel Tile Finishes	
Option	Specification Description	Specification
Paint Option	3-digit painted finish	See Beyond Painted Steel Tile Finishes

Specification Example: BY-STILESTEEL.####.P8X

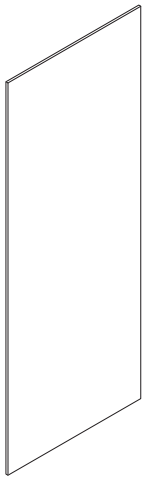

Fabric-Wrapped Tile

Base Model	Description	Specification
BY-STILEFAB	Fabric-Wrapped Tile, Non-Ported	BY-STILEFAB
Configuration ID	Specification Description	
Top Mounting	Field will populate if field-installed: Standard Top	
Enhanced Acoustic	Standard Enhanced	
Tile Type	Fabric	
Width	9" -60" in ¼" increments	
Height	6½" - 118½" in ⅙" increments	
Assembly Type	Field will populate if field-installed: Field Installed	
Reveal Type	Butt Joint Half Inch	
Tile Base	Standard Standard Base, Tile to the Floor Electrical Base, Tile to the Floor	
Fabric Finish	See Beyond Fabric Finishes	
Option	Specification Description	Specification
Fabric Grade Selection and Color Option	Select Fabric Finish	See Beyond Fabric Finishes

Specification Example: BY-STILEFAB.####.APN911

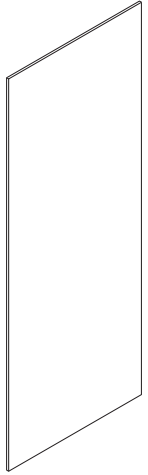

Veneer Tile

Base Model	Description	Specification
BY-STILEVEN	Veneer Tile, Non-Ported	BY-STILEVEN
Configuration ID	Specification Description	
Top Mounting	Field will populate if field-installed: Standard Top	
Enhanced Acoustic	Standard Enhanced	
Tile Type	Veneer	
Width	8" -60" in 1/4" increments	
Height	6 1/2" - 118 1/8" in 1/8" increments	
Assembly Type	Field will populate if field-installed: Field Installed	
Reveal Type	Butt Joint Half Inch	
Veneer Base	Standard Standard Base, Tile to the Floor Electrical Base, Tile to the Floor	
FSC	FSC Certified Not FSC Certified	FSC X
Veneer Finish	See Beyond Veneer Finishes	

Option	Specification Description	Specification
FSC Option	FSC Certified Standard Wood (Not FSC Certified)	FSC X
Veneer Grade and Color Option	Select Veneer Finish	See Beyond Veneer Finishes

Specification Example: BY-STILEVEN.####.NE800

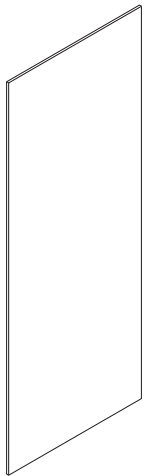

Laminate Tile

Base Model	Description	Specification
BY-STILELAM	Laminate Tile, Non-Ported	BY-STILELAM
Configuration ID	Specification Description	
Top Mounting	Field will populate if field-installed: Standard Top	
Enhanced Acoustic	Standard Enhanced	
Tile Type	Laminate	
Width	8" -60" in 1/4" increments	
Height	6 1/2" - 118 1/8" in 1/8" increments	
Assembly Type	Field will populate if field-installed: Field Installed	
Reveal Type	Butt Joint Half Inch	
Tile Base	Standard Standard Base, Tile to the Floor Electrical Base, Tile to the Floor	
FSC	FSC Certified Not FSC Certified	FSC X
Laminate Finish	See Beyond Laminate Finishes	

Option	Specification Description	Specification
FSC Option	FSC Certified Standard Wood (Not FSC Certified)	FSC X
Laminate Grade and Color Option	Select Laminate Finish	See Beyond Laminate Finishes

Specification Example: BY-STILELAM.####.LVT1

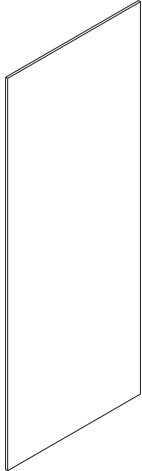

Glass Markerboard Tile

Base Model	Description	Specification
BY-STILEGLASSMB	Glass Markerboard Tile, Non-Ported	BY-STILEGLASSMB
Configuration ID	Specification Description	
Top Mounting	Field will populate if field-installed: Standard Top	
Enhanced Acoustic	Standard Enhanced	
Tile Type	Glass Markerboard	
Width	12" - 60" in ¼" increments	
Height	6½" - 114¾" in ⅛" increments	
Assembly Type	Field will populate if field-installed: Field Installed	
Reveal Type	Butt Joint Half Inch	
Tile Base	Standard Standard Base Electrical Base	
Glass Markerboard Finish	See Glass Markerboard Finishes below	
Option	Specification Description	Specification
Glass Selection	⅜" Back-Painted, Low Iron, Markerboard, White	OA
	⅜" Back-Painted, Low Iron, Markerboard, Magnetic, White	OB

Specification Example: **BY-STILEGLASSMB.####.OA**

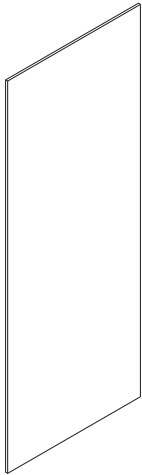

Steel Markerboard Tile

Base Model	Description	Specification
BY-STILESTEELMB	Steel Markerboard Tile, Non-Ported	BY-STILESTEELMB
Configuration ID	Specification Description	
Top Mounting	Field will populate if field-installed: Standard Top	
Enhanced Acoustic	Standard Enhanced	
Tile Type	Steel Markerboard	
Width	8" - 50" in ¼" increments	
Height	6½" - 114¾" in ⅛" increments	
Assembly Type	Field will populate if field-installed: Field Installed	
Reveal Type	Butt Joint Half Inch	
Tile Base	Standard Standard Base, Tile to the Floor Electrical Base, Tile to the Floor	
Steel Markerboard Finish	Steel Markerboard Tile	

Specification Example: **BY-STILESTEELMB.####**

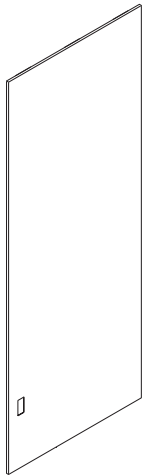

Ported 18" AFF

Base Model	Description	Specification
BY-SPTILESTEEL	Painted Steel Tile, Ported	BY-SPTILESTEEL
Configuration ID	Specification Description	
Top Mounting	Field will populate if field-installed: Standard Top	
Enhanced Acoustic	Standard Enhanced	
Tile Type	Steel	
Width	30"W - 60"W in ¼" increments	
Height	9¼"H - 118⅝"H in ⅛" increments	
Assembly Type	Field will populate if field-installed: Field Installed	
Reveal Type	Butt Joint Half Inch	
Tile Base	Standard Standard Base, Tile to the Floor Electrical Base, Tile to the Floor	
Paint Finish	See Beyond Painted Steel Tile Finishes	
Port Quantity	1-4	
Port 1 Type	Single Port Double Port Quad Port	
Port 1 Location	Left Center Right	
Port 2-4 Type	Field(s) will populate if more than 1 port is selected. Options are the same as Port 1 Type	
Port 2-4 Location	Field(s) will populate if more than 1 port is selected. Options are the same as Port 1 Location	

Option	Specification Description	Specification
Paint Option	3-digit painted finish	See Beyond Painted Steel Tile Finishes

Specification Example: BY-SPTILESTEEL.####.P7L

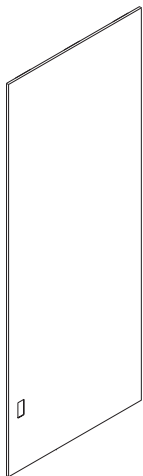

Ported 18" AFF

Base Model	Description	Specification
BY-SPTILEFAB	Fabric-Wrapped Tile, Ported	BY-SPTILEFAB
Configuration ID	Specification Description	
Top Mounting	Field will populate if field-installed: Standard Top	
Enhanced Acoustic	Standard Enhanced	
Tile Type	Fabric	
Width	30"W - 60"W in ¼" increments	
Height	9¼"H - 118⅝"H in ⅛" increments	
Assembly Type	Field will populate if field-installed: Field Installed	
Reveal Type	Butt Joint Half Inch	
Tile Base	Standard Standard Base, Tile to the Floor Electrical Base, Tile to the Floor	
Fabric Finish	See Beyond Fabric Finishes	
Port Quantity	1-4	
Port 1 Type	Single Port Double Port Quad Port	
Port 1 Location	Left Center Right	
Port 2-4 Type	Field(s) will populate if more than 1 port is selected. Options are the same as Port 1 Type	
Port 2-4 Location	Field(s) will populate if more than 1 port is selected. Options are the same as Port 1 Location	

Option	Specification Description	Specification
Fabric Grade Selection and Color Option	Select Fabric Finish	See Beyond Fabric Finishes

Specification Example: BY-SPTILEFAB.####.APN911

BEYOND FINISHES & FABRICS
BEYOND PANELS & TRIM
BEYOND DOORS
BEYOND CONNECTORS
BEYOND ELECTRICAL & DATA
BEYOND FRAMELESS PRIVACY TILE SYSTEM
BEYOND VIZ

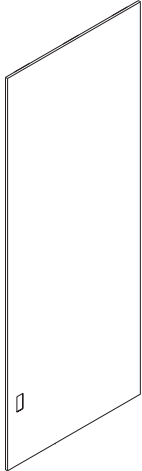

Ported 18" AFF

Base Model	Description	Specification
BY-SPTILEVEN	Veneer Tile, Ported	BY-SPTILEVEN
Configuration ID	Specification Description	Specification
Top Mounting	Field will populate if field-installed: Standard Top	
Enhanced Acoustic	Standard Enhanced	
Tile Type	Veneer	
Width	30"W - 60"W in ¼" increments	
Height	9¼"H - 118½"H in ¼" increments	
Assembly Type	Field will populate if field-installed: Field Installed	
Reveal Type	Butt Joint Half Inch	
Tile Base	Standard Standard Base, Tile to the Floor Electrical Base, Tile to the Floor	
FSC	FSC Certified Not FSC Certified	FSC X
Veneer Finish	See Beyond Veneer Finishes	
Port Quantity	1-4	
Port 1 Type	Single Port Double Port Quad Port	
Port 1 Location	Left Center Right	
Port 2-4 Type	Field(s) will populate if more than 1 port is selected. Options are the same as Port 1 Type	
Port 2-4 Location	Field(s) will populate if more than 1 port is selected. Options are the same as Port 1 Location	
Option	Specification Description	Specification
FSC Option	FSC Certified Standard Wood (Not FSC Certified)	FSC X
Veneer Grade and Color Option	Select Veneer Finish	See Beyond Veneer Finishes

Specification Example: BY-SPTILEVEN.####.NE800

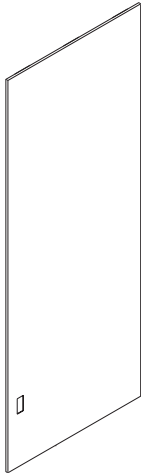

Ported 18" AFF

Base Model	Description	Specification
BY-SPTILELAM	Laminate Tile, Ported	BY-SPTILELAM
Configuration ID	Specification Description	
Top Mounting	Field will populate if field-installed: Standard Top	
Enhanced Acoustic	Standard Enhanced	
Tile Type	Laminate	
Width	30"W - 60"W in ¼" increments	
Height	9¼"H - 118½"H in ¼" increments	
Assembly Type	Field will populate if field-installed: Field Installed	
Reveal Type	Butt Joint Half Inch	
Tile Base	Standard Standard Base Electrical Base	
FSC	FSC Certified Not FSC Certified	FSC X
Laminate Finish	See Beyond Laminate Finishes	
Port Quantity	1-4	
Port 1 Type	Single Port Double Port Quad Port	
Port 1 Location	Left Center Right	
Port 2-4 Type	Field(s) will populate if more than 1 port is selected. Options are the same as Port 1 Type	
Port 2-4 Location	Field(s) will populate if more than 1 port is selected. Options are the same as Port 1 Location	
Option	Specification Description	Specification
FSC Option	FSC Certified Standard Wood (Not FSC Certified)	FSC X
Veneer Grade and Color Option	Select Laminate Finish	See Beyond Laminate Finishes

Specification Example: BY-SPTILELAM.###.LVT1

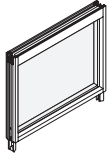

Stacker

Base Model	Description	Specification
BY-STILEGLASS	Integrated Glass Tile/Stacker, Non-Ported	BY-STILEGLASS
Configuration ID	Specification Description	
Product	Uniform Framed Glass Solid Wall	
Base Horizontal	Standard Integrated Mounting Rail	
Width	8" - 60" in 1/4" increments as an integrated glass tile 8" - 120" in 1/4" increments as a stacker above a framed/solid panel or door frame including freeway	
Height	9 1/2" - 108 1/4" in 1/4" increments as an integrated glass tile 9 1/2" - 120" in 1/4" increments as a stacker above a framed/solid panel 9 1/2" - 58" as a stacker above a door frame or freeway 10 1/2" - 36 1/2" in 1/4" increments as a stacker above a framed/solid panel or door frame with integrated mounting rail	
Enhanced Acoustic	Standard Enhanced	
Option	Specification Description	Specification
Glass Selection	QA: 1/4" Tempered, Clear	
	QB: 1/4" Tempered, Low Iron	
	QC: 1/4" Laminated, Clear	
	QD: 1/4" Laminated, Low Iron	
	QE: 1/4" Laminated, Clear, Translucent White	
	QF: 1/4" Laminated, Low Iron, Markerboard	
	QG: 1/4" Laminated, High Performance, Clear	
	QH: 1/4" Laminated, High Performance, Low Iron	
	QL: 1/4" Laminated, Clear, Markerboard	
	TA: 3/8" Tempered, Clear	
	TB: 3/8" Tempered, Low Iron	
	TC: 3/8" Laminated, Clear	
	TD: 3/8" Laminated, Low Iron	
	TE: 3/8" Laminated, Clear, Translucent White	
	TF: 3/8" Laminated, Low Iron, Markerboard	
	TG: 3/8" Laminated, High Performance, Clear	
	TH: 3/8" Laminated, High Performance, Low Iron	
TL: 3/8" Laminated, Clear, Markerboard		
TN: 3/8" Back-to-Back Back-Painted, Low Iron, Turquoise		
TP: 3/8" Back-to-Back Back-Painted, Low Iron, Cherry		
TQ: 3/8" Back-to-Back Back-Painted, Low Iron, Lawn		
TR: 3/8" Back-to-Back Back-Painted, Low Iron, Jet		
TS: 3/8" Back-to-Back Back-Painted, Low Iron, Mandarin		
Paint Color Selection	3-digit painted or anodized finish	See Beyond Frame Finishes

Specification Example: BY-STILEGLASS.####.QA.P8X

Panels & Trim

Beyond® — Wall-Mounted Markerboard

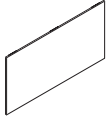

Markerboard

Base Model	Description	Specification
BY-GLASSWALLMB	Wall-Mounted Glass Markerboard	BY-GLASSWALLMB

Option	Specification Description	Specification
Width	48"W	4800W
	72"W	7200W
	96"W	9600W
Height	48"H	4800H
Glass Selection	³ / ₁₆ " Back-Painted, Low Iron, Markerboard, White	OA
	³ / ₁₆ " Back-Painted, Low Iron, Markerboard, Magnetic, White	OB

Specification Example: **BY-GLASSWALLMB.4800W.4800H.OA**

Standard

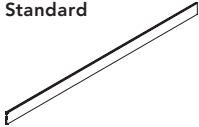

Full View



Profile View

Base Model	Description	Specification
BY-FSBT	Base Trim	BY-FSBT

Configuration ID	Specification Description
Product	Beyond
Product Type	Solid or Framed
Dimension	96" 120"
Trim Type	Base
Enhanced Acoustic	Standard Enhanced
Trim Use	Universal
Trim Style	Standard
Finish Color	Painted or Anodized Finishes

Option	Specification Description	Specification
Paint Color Selection	3-digit painted or anodized finish	See Beyond Frame Finishes

Specification Example: **BY-FSBT.####.P8X**

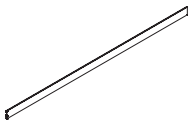

No Ports

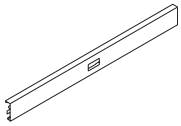

Single Receptacle Port

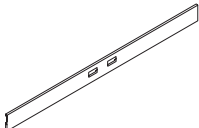

Double Receptacle Port

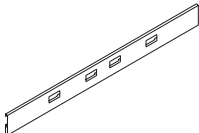

Double Receptacle Ports with Double Data Ports

Base Model	Description	Specification
BY-FSBTE	Electrical Base Trim	BY-FSBTE

Configuration ID	Specification Description
Product	Beyond
Product Type	Solid or Framed
Dimension	96 or 120 - Non-Ported 60" - Single, Double, Single - Chicago, Double - Chicago 48" - Double with Data
Trim Type	Base
Enhanced Acoustic	Standard Enhanced
Trim Use	Straight Straight Ported
Trim Style	Electrical
Port Type	<i>Field Will Populate if Ported Specified</i> Single Double Double with Data Single - Chicago Double - Chicago
Finish Color	Painted or Anodized Finishes

Option	Specification Description	Specification
Paint Color Selection	3-digit painted or anodized finish	See Beyond Frame Finishes

Specification Example: **BY-FSBTE.####.P8X**

BEYOND
FINISHES & FABRICS
TABLE OF CONTENTS

BEYOND
PANELS & TRIM

BEYOND
DOORS

BEYOND
CONNECTORS

BEYOND
ELECTRICAL & DATA

BEYOND
FRAMELESS PRIVACY
TILE SYSTEM

BEYOND
VIZ



Base Model	Description	Specification
BY-ZIPPER	Zipper	BY-ZIPPER
Configuration ID	Specification Description	
Color Selections	Black-Kloeber (20 gloss)	E4
	Brownstone	BW
	Designer White	DW
	Grey	EC
	Warm Tone	EF

Specification Example: **BY-ZIPPER.E4**



Base Model	Description	Specification
BY-ZIPPERBULK	Zipper (QTY 75)	BY-ZIPPERBULK
Configuration ID	Specification Description	
Color Selections	Black-Kloeber (20 gloss)	E4
	Brownstone	BW
	Designer White	DW
	Grey	EC
	Warm Tone	EF

Specification Example: **BY-ZIPPERBULK.E4**



Base Model	Description	Specification
BY-AZIPPER	Adjustable Angle Zipper	BY-AZIPPER
Configuration ID	Specification Description	
Color Selections	Black-Kloeber (20 gloss)	E4
	Grey	EC

Specification Example: **BY-AZIPPER.E4**

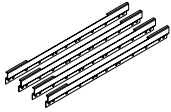

Flush Mount Bracket

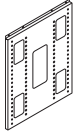

Integrated Mounting Rail Bracket

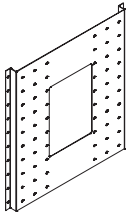

Variable Height Mounting Bracket

Base Model	Description	Specification
BY-TVBRACKET	TV Mounting Bracket	BY-TVBRACKET

Option	Specification Description	Specification
Mounting Type	Integrated Mounting Rail	IRMB
	Flush	FMB
	Variable Height	VHMB
Paint Color Selection	3-digit painted finish	See Beyond Frame Finishes

Specification Example: BY-TVBRACKET.IRMB.P8X

Note: Specify Anodized Silver - PR0 to coordinate with Clear, Anodized frame



Hanging Bracket

Base Model	Description	Specification
BY-FURNBRACKET	Furniture Adapter Bracket	BY-FURNBRACKET
Option	Specification Description	Specification
Size	Small - 8"H	S
	Large - 11"H	L
	Worksurface - 3"H	W
Paint Color Selection	3-digit painted finish	See Beyond Frame Finishes

Specification Example: **BY-FURNBRACKET.S.P8X**

Note: Specify Anodized Silver - PR0 to coordinate with Clear, Anodized frame



Accessory Hook

Base Model	Description	Specification
BY-FSHOOK	Accessory Hook (Qty. 6)	BY-FSHOOK
Paint Color Selection	3-digit painted finish	See Beyond Frame Finishes

Specification Example: **BY-FSHOOK.P8X**

Note: Specify Anodized Silver - PR0 to coordinate with Clear, Anodized frame



Coat Hook

Base Model	Description	Specification
BY-FSCOATHOOK	Coat Hook (for Integrated Mounting Rail)	BY-FSCOATHOOK
Option	Specification Description	Specification
Quantity	Quantity 1	1
	Quantity 50	50
	Quantity 250	250
	Quantity 500	500
Paint Color Selection	3-digit painted finish	See Beyond Frame Finishes

Specification Example: **BY-FSCOATHOOK.50.P8X**

Note: Specify Anodized Silver - PR0 to coordinate with Clear, Anodized frame

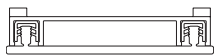

Adapter

Base Model	Description	Specification
BY-FSOFFMOD	Off-Modular Adapter, Stride-to-Beyond (for Integrated Mounting Rail)	BY-FSOFFMOD
Configuration ID	Specification Description	
Product	Beyond	
Dimension	84"	
Trim Type	Wall Channel	
Trim Use	Stride Adapter	
Finish Color	Painted or Anodized Finishes	

Option	Specification Description	Specification
Paint Color Selection	3-digit painted or anodized finish	See Beyond Frame Finishes

Specification Example: **BY-FSOFFMOD.####.P8X**

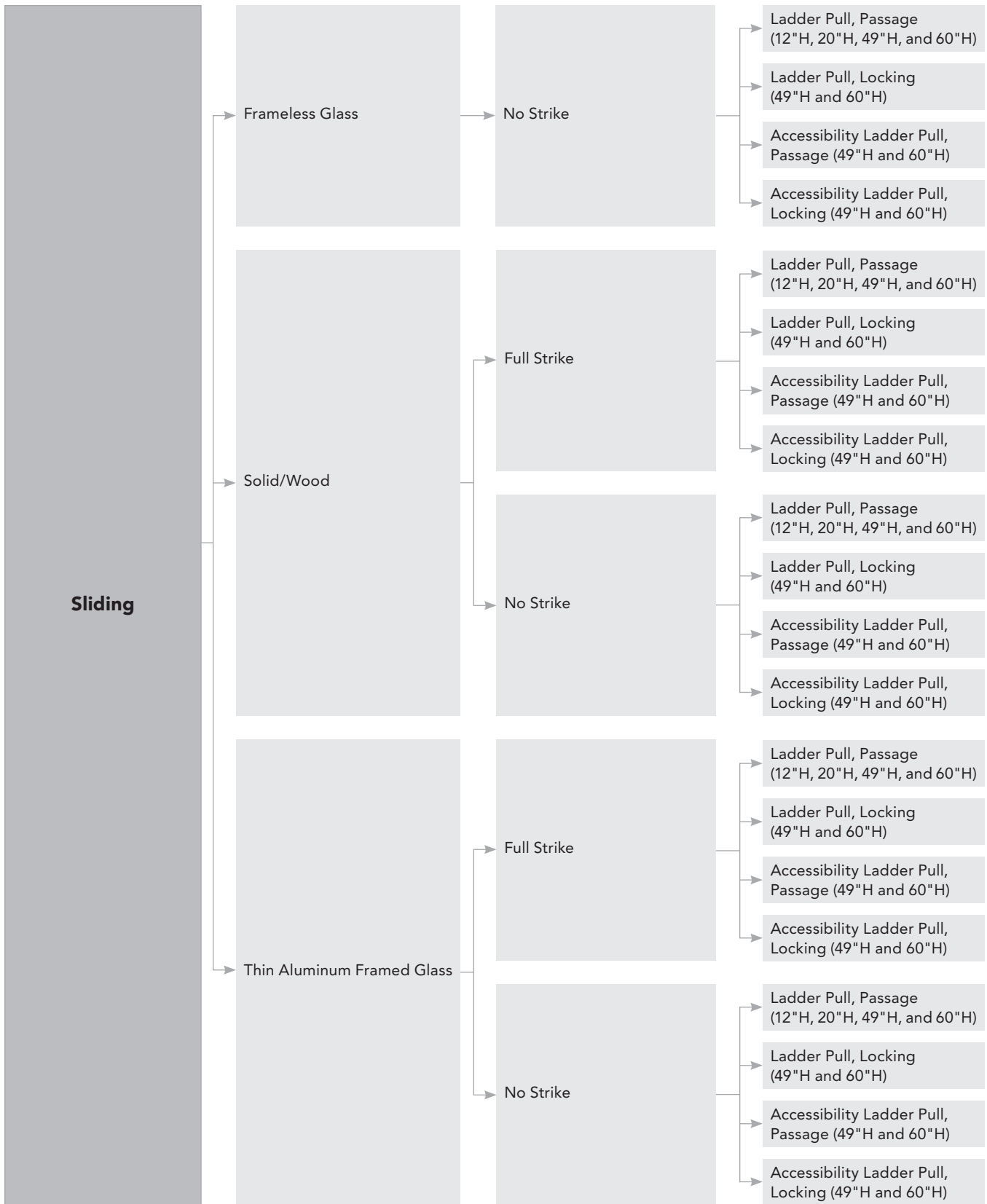

Continued on next page

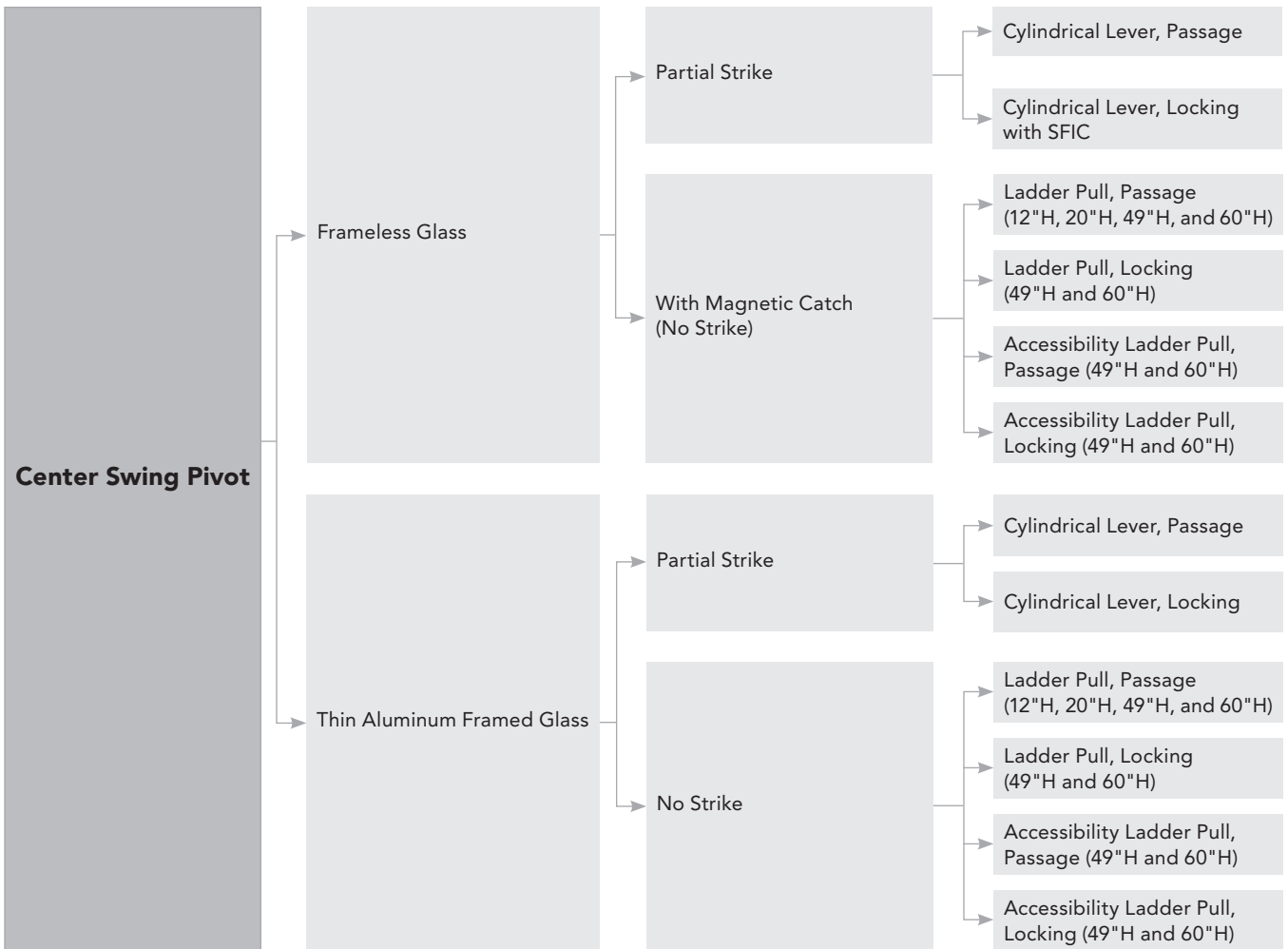

Continued on next page

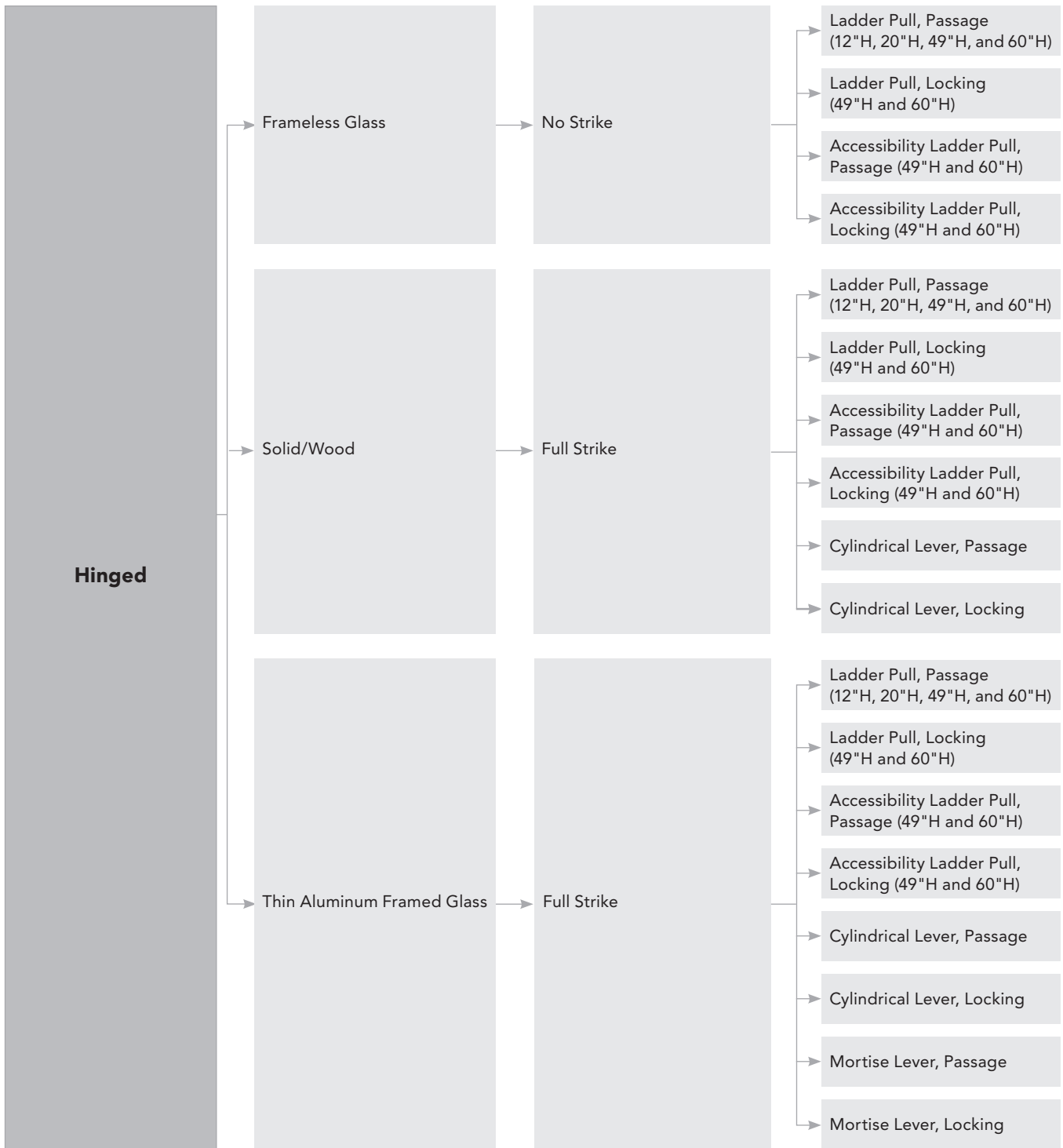

General Information

- Door components are ordered separately.
- Beyond doors are universal and work with Beyond frameless glass, framed glass, and solid panels.
- Doors have a maximum height of 120" and a minimum height of 86". The only exclusions are the 48"W module aluminum framed doors which have a maximum height of 108¾" and the single 7'H sliding door with transom which is at a fixed height of 7'H.
 - Heights are available in ¼" increments.
- Door module width varies by door type.
- Utilize an adjacent door wall channel when connecting a door directly to drywall.
- When connecting a door frame to frameless glass, a frameless glass adapter must be used. The adapters add ½" planning dimension per adapter.

Planning Dimensions



Swing Door Frame-to-Frameless Adapter

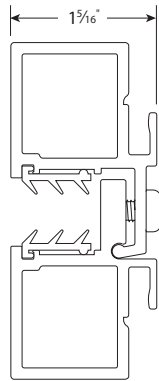

Swing Door Frame-to-Frameless Adapter



Sliding Door Frame-to-Frameless Adapter

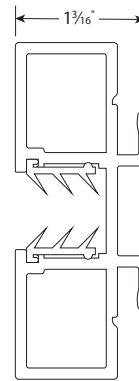

Sliding Door Frame-to-Frameless Adapter

- Doors specified at nominal height have a ½" planned clearance between the bottom of the door and the floor.
 - Door clearances should be confirmed on the job site with field measures for both the open and closed positions of sliding and swing doors.
- Doors can be specified as frameless glass, aluminum framed glass, or solid (veneer, laminate or painted wood).
 - Frameless glass doors are available in tempered clear and tempered low-iron.
 - Aluminum framed doors require specification of glass thickness, and glass type.
 - Specify ¼" or ⅜" glass.
 - Solid doors can be specified as veneer, laminate or painted wood.
 - [See the Materials and Finishes section for finish selection details.](#)
- Door frames are available in anodized aluminum or painted aluminum. [See the Materials and Finishes section](#) for finish selection details.

General Information

- Sliding doors can be mounted on the interior or exterior of the room.
- Adjacent panels of the following dimensions are required next to sliding doors to support the door track and to eliminate interference with another panel or door:
 - 42" door module requires a 36"W minimum adjacent panel.
 - Clearance is 33¾" on standard and 33¼" on full strike doors.
 - 48" door module requires a 42"W minimum adjacent panel.
 - Clearance is 39¾".
 - 78" door module requires a 33½"W minimum adjacent panel on both sides of the door.
 - Clearance is 63½".
- Sliding door tracks are available in two options.
 - Standard
 - Slow Close/Slow Open
 - Incorporates a motion-dampening mechanism to support soft closures and openings for sliding doors.
- Sliding doors utilize door pulls. [See the Door Hardware pages of the Doors section](#) for available options.
- Optional frameless glass sliding door trailing edge seals are available for improved acoustical performance.
 - Trailing edge seal is field-applied to the trailing edge of the frameless glass door with pre-applied adhesive tape.



Trailing Edge Seal

Single Sliding Doors

- Doors and door frames are non-handed.
- Available in two door module sizes.
 - 42" door module is available with all door types.
 - 48" door module is only available on aluminum framed and solid doors.
 - Maximum specified height of 108¾"
 - Single 7'H doors with transom can be utilized for heights above 108¾".
 - ¾" glass thickness only available when specified at 7'H with transom. All other heights are available only with ¼" thick glass.
- Sliding doors can be locked by specifying the locking ladder pull options or specifying a full strike frame with locking into the frame.

- Enhanced Acoustics
 - Enhanced acoustics are available on all sliding doors except thin aluminum framed glass.
 - The enhanced acoustical option includes a seal inside the sliding door track and a bottom seal to reduce sound transmission.
 - All doors specified after the launch of the acoustical enhancements can be retrofitted with bottom seals and track seals with a retrofit kit.
 - If enhanced acoustics are specified, this option will appear on the door frame and track bill of materials. It will appear on the aluminum framed door bill of materials. It will NOT appear on the frameless glass or solid door model bill of materials due to the acoustical enhancement components being included in the other models.

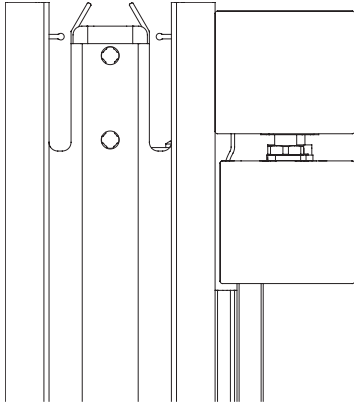

Sliding Door Track with Enhanced Acoustics

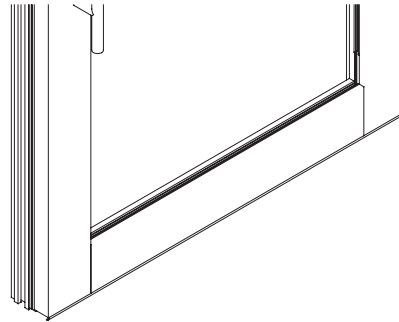

Aluminum Framed Door with Enhanced Acoustics

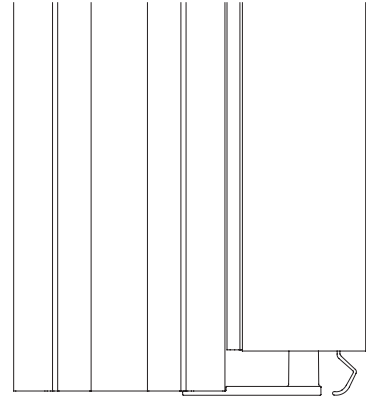

Solid Door with Enhanced Acoustics

Sliding Doors

- Frameless glass standard sliding doors are also available with adjustable footers.
 - Adjustable footers attach to the bottom of the frameless glass doors and allow for $\pm 1/2$ " adjustment. Footers can be adjusted down to minimize the space between the bottom of the door and the floor. Doors with footers specified at nominal height have a $1/4$ " planned clearance between the bottom of the door and the floor.
 - Adjustment can occur after the door is hung in place for ease of installation.
 - Footer models are non-handed.
 - Specify the door model for adjustable footers and the footer model separately.
 - Footers work with full strike option on single sliding doors.

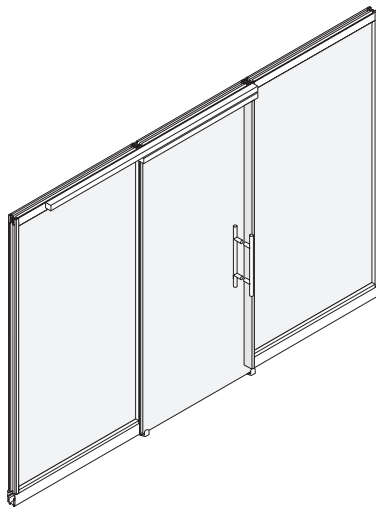

Sliding Frameless Glass

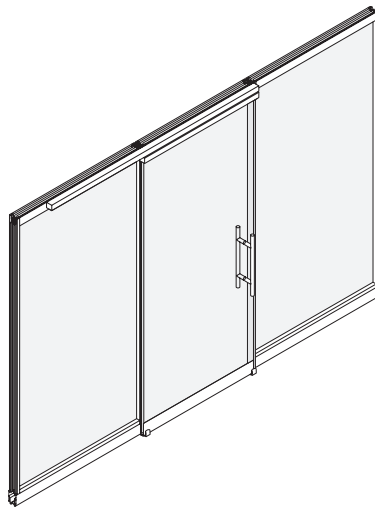

Sliding Frameless Glass with Adjustable Footer

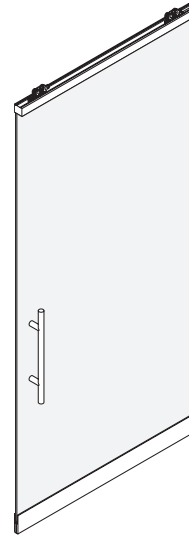

Frameless Glass Door with Adjustable Footer

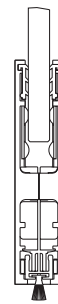

Profile View of Adjustable Footer

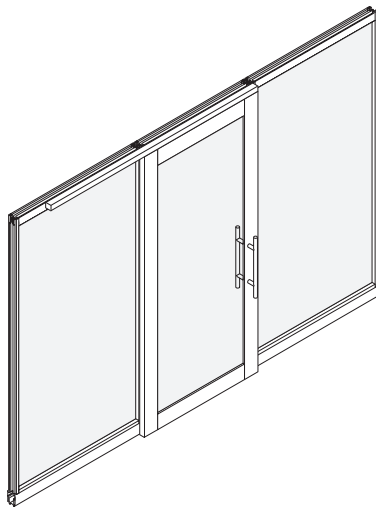

Sliding Aluminum Framed Glass

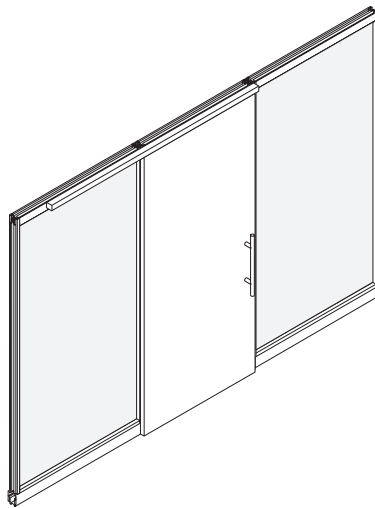

Sliding Solid

Single Sliding Doors - Full Strike Option

- A full strike frame can be used with sliding doors for locking purposes and/or to enhance acoustics.
- Doors are non-handed. Door frames are handed.
- Door frame models are dependent upon door type.
 - Frameless glass door frames
 - Aluminum framed glass or solid door frames
- Available in two door module sizes.
 - 42" door module is available with all door types.
 - 48" door module is only available in aluminum framed glass doors.
 - Maximum specified height of 108¾"
- Frameless glass full strike sliding doors are also available with adjustable footers.
- Full strike doors can be locked utilizing one of the following options:
 - Locking ladder pull
 - Door lock that locks into full strike frame. [See Door Hardware on page 208 for details.](#)

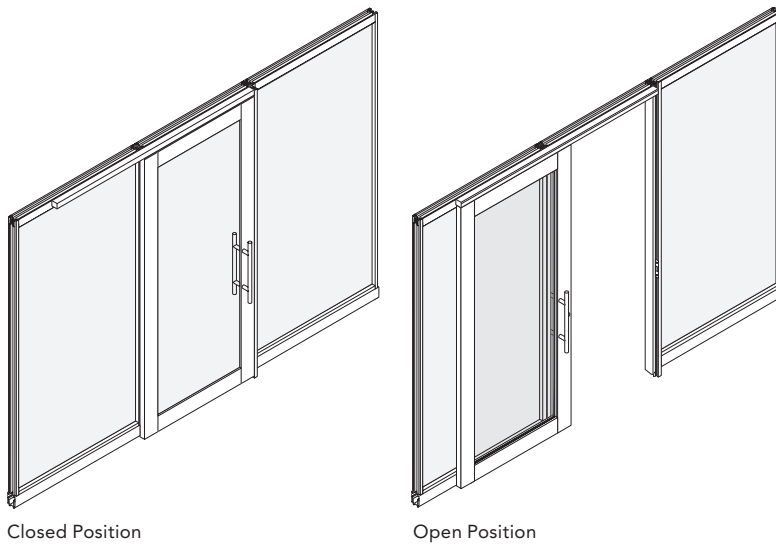

Full Strike Sliding Aluminum Framed Door with Lock

Double Sliding Doors

- 78" door module is available with all sliding door materials (frameless, aluminum framed glass, thin aluminum framed glass, solid).
- Specify double door models for doors, door frames, sliding door track, and mounting hardware.
- Order QTY (2) doors for double sliding door application.
- Frameless glass double doors incorporate a field-installed clear polymer edge to protect glass edges when the doors are closed.
- Double sliding doors can be locked by specifying two of the locking ladder pull options.
- Double sliding doors come with slow close/slow open door tracks.
- Blocking may be required above a double sliding door due to the weight of the door at the center of the header.

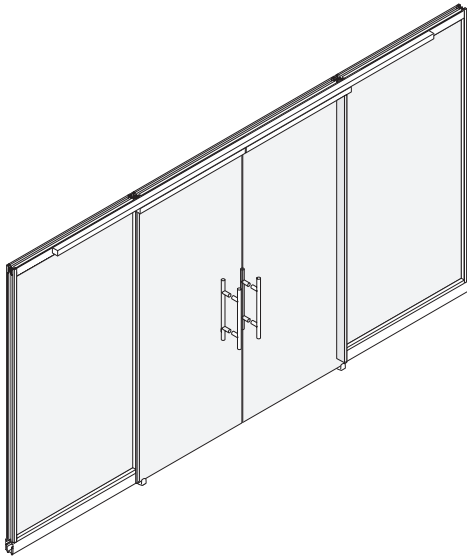

Sliding Frameless Glass, Double

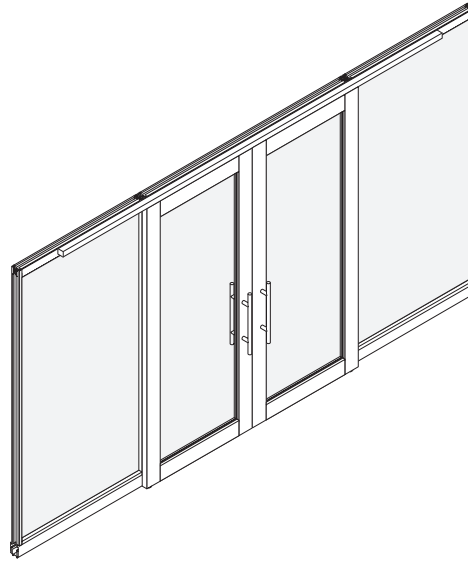

Sliding Aluminum Framed, Double

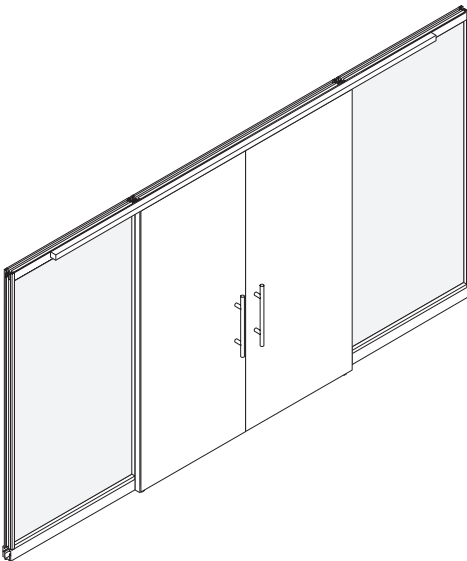

Sliding Solid, Double

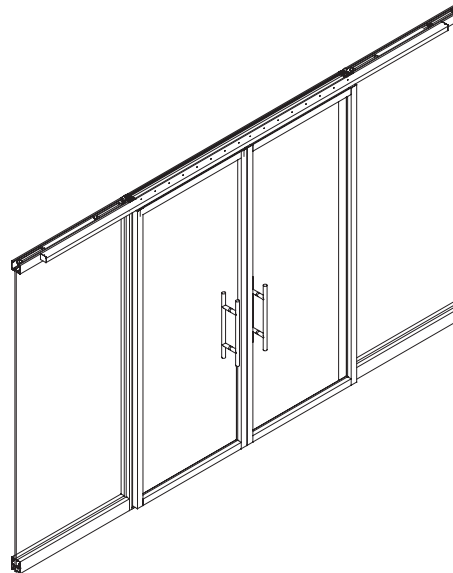

Sliding Thin Aluminum Framed, Double

Single Sliding Doors under Transom

- Door is specified as a single 7'H door with transom. The door is a fixed height. Note that the door leaf is 85" and the frame is 84". The height of the frame model is from the top of the transom to the finished floor.
- Glass transom above door is available from 10 $\frac{3}{4}$ " to 37 $\frac{7}{8}$ " in $\frac{1}{4}$ " increments and in widths of 42" and 48".
- Doors and door frames are non-handed.
- Can only be used with framed glass and solid walls.
 - Must use integrated mounting rail when used with framed and solid walls.
- Door frames incorporate a glass transom or clerestory.
 - Specify $\frac{1}{4}$ " or $\frac{3}{8}$ " glass for the transom/clerestory section.
 - Specify glass color. [See Glass Types section for details.](#)
- Available in two door module sizes.
 - Both 42" and 48" module doors are available with all sliding door types.
- Not available in full strike.
- 7'H sliding doors with transom can be locked by specifying a locking ladder pull.
- Can be specified with enhanced acoustics.

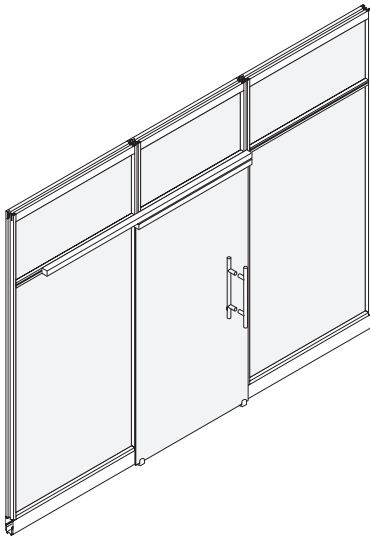

7'H Frameless Glass Sliding, Single with Transom*

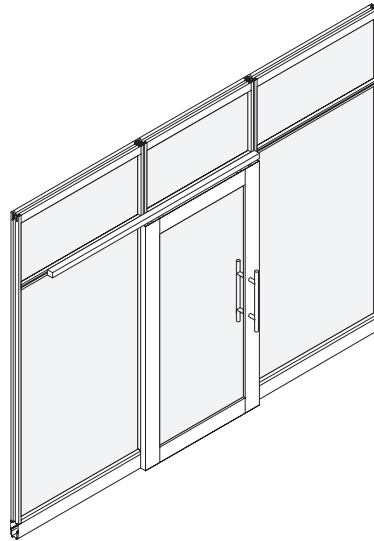

7'H Aluminum Framed Glass Sliding, Single with Transom*

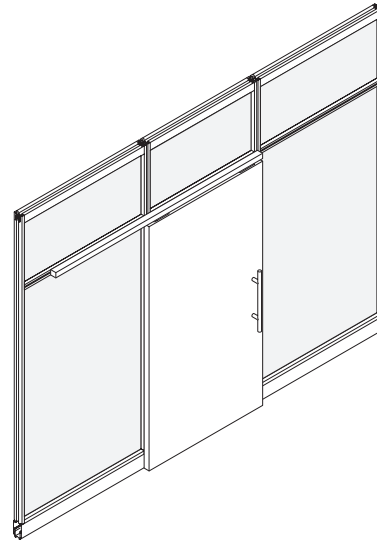

7'H Solid Sliding, Single with Transom*

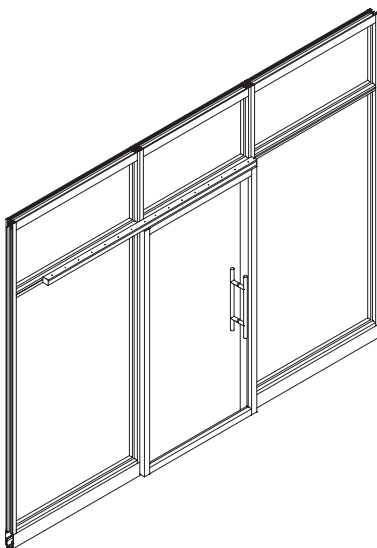

7'H Thin Aluminum Framed Glass Sliding, Single with Transom

Swing Doors

Swing doors on Beyond use two main mechanisms: center swing pivot and hinge. Center swing pivot doors offer greater flexibility as the strike plate on the partial strike frames can be reversed, allowing the door to be non-handed.

Center Swing Pivot Doors

- All single center swing pivot doors utilize a 39" door module.
 - Clearance is 33¼" on solid and aluminum framed doors.
 - Clearance is 32½" on frameless glass center swing pivot from the hinge patch cover to the frame on frameless glass doors.
- Door frames for center swing pivot doors must be anchored to the floor to provide appropriate support for the door.
- Center swing pivot doors are non-handed.
- If specifying a swing door within the middle of a run, it is recommended to use a hinged option rather than a center swing pivot. The solid and aluminum framed hinged door allows for the full 180° swing where the door stop can be placed out of the walkway. However, the center swing pivot door is restricted to approximately 90° of opening.
- Center swing pivot doors come in frameless glass, aluminum framed glass, and solid (veneer, laminate and painted wood).
- Door frames are available in partial strike.
 - The strike plate for partial strike door frames can be reversed, allowing the door frame to be non-handed.
 - Frameless glass doors specified with a Ladder Pull use a frame with a standard strike.
- On frameless glass doors:
 - Mounting hardware is non-handed.
 - Top and bottom hinge patch cover includes high-density cast body.
 - Includes surface-mounted and floor-mounted center swing pivots.
- On aluminum framed glass doors, base rails are available in two options.
 - 5" base rail.
 - 10" base rail – required in some locations to comply with the Americans with Disabilities Act. This option is recommended unless it is known that the 5" base rail is approved for the installation location.
- Door levers are available in passage (non-locking) or standard format interchangeable core (SFIC) locking options.

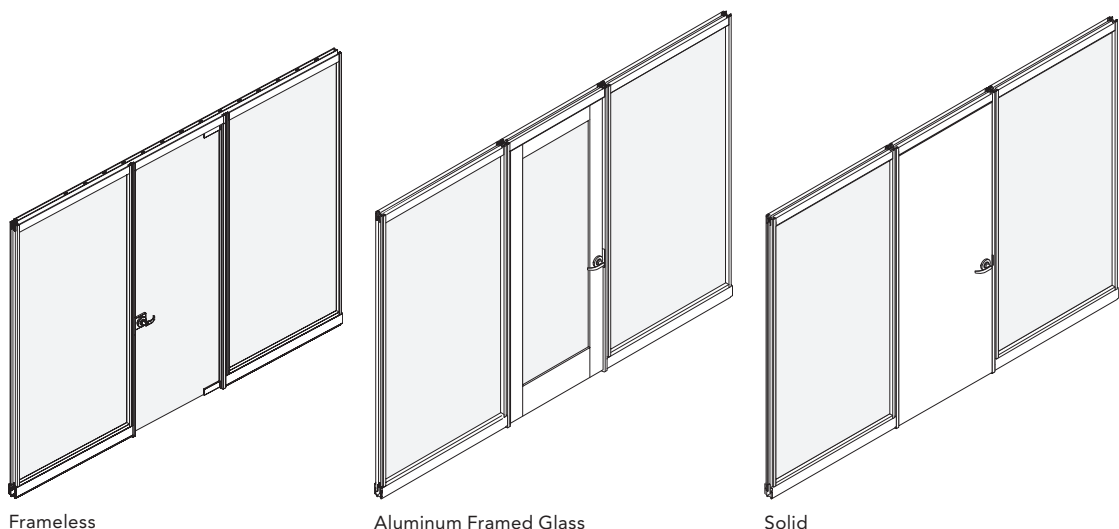
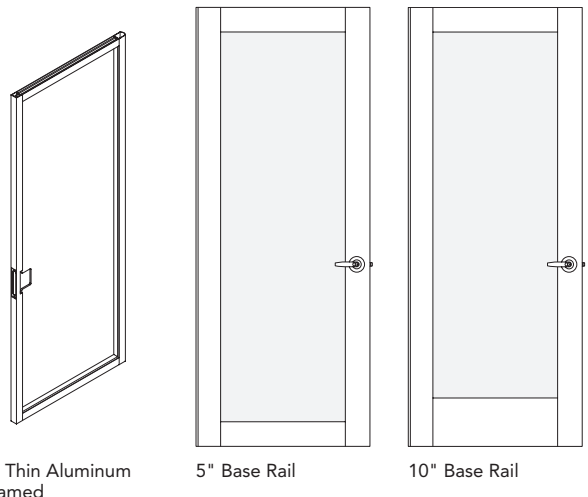

- Frameless center swing pivot doors can be specified with ladder pulls. A magnetic catch must be specified along with a corresponding door and frame designed for door pulls.

General Information

- All single hinged doors utilize a 39" door module.
 - Clearance is 33 $\frac{3}{8}$ " on solid or aluminum framed doors.
 - Clearance is 34 $\frac{1}{8}$ " on frameless glass hinged doors.
- All double hinged doors utilize a 75" door module.
 - Clearance is 67 $\frac{3}{8}$ " on solid and aluminum framed doors.
 - Clearance is 68 $\frac{3}{8}$ " on frameless glass hinged doors.
- Door frames for hinged doors must be anchored to the floor to provide appropriate support for the door.
- Handedness
 - Frameless glass hinged doors and door frames are non-handed.
 - Aluminum framed and solid hinged doors and door frames are handed.
- If specifying a swing door within the middle of a run, it is recommended to use a hinged option rather than a center swing pivot. The solid and aluminum framed hinged door allows for the full 180° swing where the door stop can be placed out of the walkway. However, the center swing pivot door is restricted to approximately 90° of opening.

Hinged Frameless Glass Doors

- Doors swing 90 degrees both inward and outward. An optional strike bracket can be installed to prevent the outward or inward swing of the door.
- Hydraulic hinges provide self-closing mechanism.
 - Automatic closing from 0 to 80 degrees.
 - Adjustable closing speed.
 - Stops at +90- or -90-degree open position.
- Utilize ladder pull options for door hardware. [See the Hinged Door Hardware pages of the Doors section](#) for details.
- Frameless glass hinged doors can be locked by specifying the locking ladder pull options.
 - The frameless glass center swing pivot door levers may also be used as a custom hardware and custom door frame option to provide additional locking options for frameless glass hinged doors.

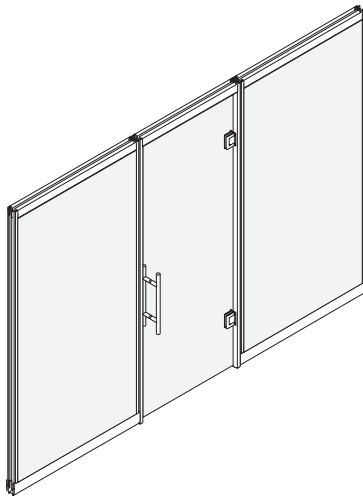

Hinged Frameless Glass

Hinged Aluminum Framed and Solid Doors

- Hinged solid and aluminum framed doors offer the most acoustic door solution with seals on three sides of the door including an optional drop seal to seal the fourth side.
 - Drop seal can be specified as an option in the door model for aluminum framed doors.
 - Drop seal for solid doors is a separate model.

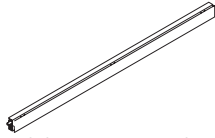

Solid Door Drop Seal

- Base rails on aluminum framed doors are available in two options.
 - 5" base rail
 - 10" base rail – required in some locations to comply with the Americans with Disabilities Act. This option is recommended unless it is known that the 5" base rail is approved for the installation location.

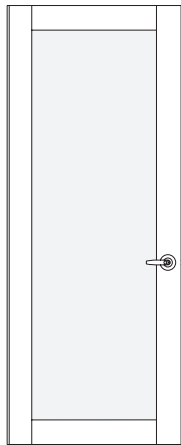

5" Base Rail

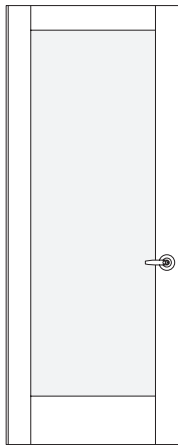

10" Base Rail

- Mounting hardware includes QTY (4) ball-bearing door hinges.
 - Square corner design
 - Measures 4" x 4"
- Door levers are available in passage or locking options.

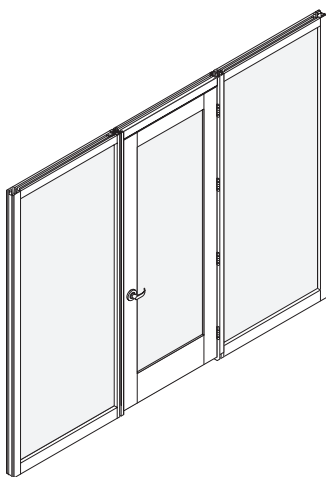

Hinged Aluminum Framed

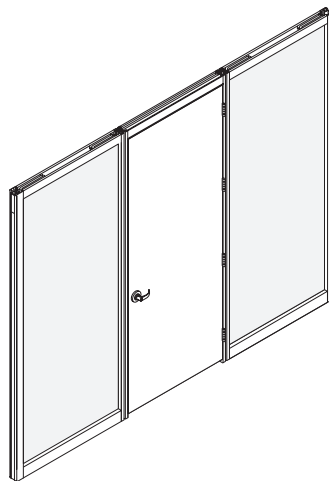

Hinged Solid

Double Hinged Doors

- Hinged Frameless Glass Double Doors
 - Utilizes the same components that are used on the single hinged frameless glass doors.
 - Order doors, door frames, and mounting hardware for double doors.
 - Order QTY (2) double frameless doors.
 - Doors swing 90 degrees both inward and outward. An optional strike bracket can be installed to prevent outward or inward swing of the door.
 - Hydraulic hinges provide self-closing mechanism.
 - Stops at +90- or -90-degree open position.
 - Available as a special without the hold-open feature for use with maglocks or other electronic access devices.
 - Double hinged frameless glass doors can be locked by specifying two of the locking ladder pull options.

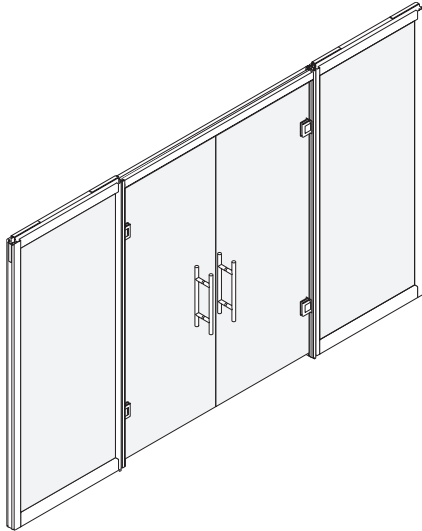

Hinged Frameless Glass, Double

- Hinged Aluminum Framed and Solid Double Doors
 - Double doors are handed and require specifying the active door.
 - Order QTY (1) active and QTY (1) inactive door.
 - The active door opens and closes with a lever.
 - The inactive door utilizes a flush bolt latch connecting into the door frame to lock out swing. Disengage latch to open the door.
 - The inactive door also incorporates an astragal for the active door to close against, and provides a light and sound seal between the doors.
 - Door levers are available in passage or locking options.

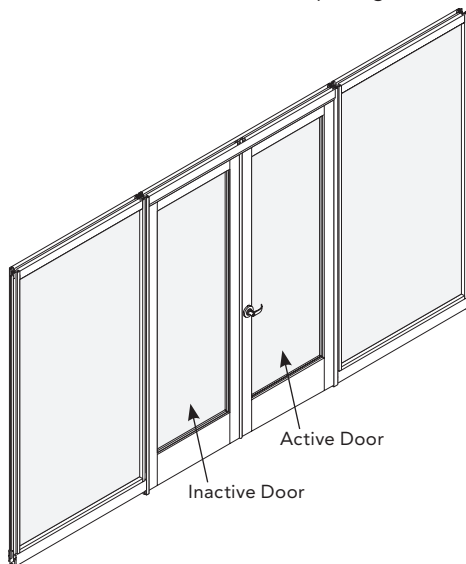

Hinged Aluminum Framed, Double

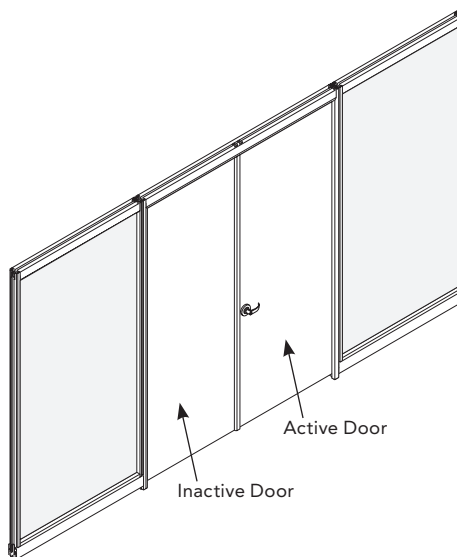

Hinged Solid, Double

Lock for Full Strike Sliding Glass Doors

- Specify with ladder pull (12", 20", 49", or 60")
- Europrofile cylinder and thumb-turn lock actuation
- European-standard keyway
- Random keying
- Master keying and key alike are available by others.
- Silver finish available.

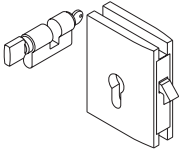

Door Lock for Full Strike Sliding Frameless Glass Doors

Lock for Full Strike Sliding Aluminum Framed Glass/Solid Doors

- Locks with mortise cylinder and thumb-turn lock actuation
- Schlage® C 5 pin keyway
- Key blank 35-100C or ilco 1145 or SC1
- Random keying
- LFIC and SFIC are available as a custom option.
- Master keying is available as a custom option.
- Silver finish available. Black finish available as custom option.

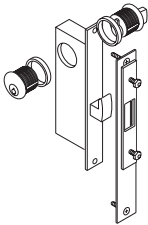

Door Lock for Full Strike Sliding Aluminum Framed Glass/Solid Doors

General Information

All exposed door hardware is available in silver or black. [See Materials and Finishes section](#) for more information.

Frameless Glass Door Levers

- For use with frameless glass door.
- Passage (non-locking), and locking with standard format interchangeable core (SFIC) lever options can be specified with Allsteel's glass pivot lever housing.

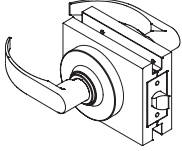

Passage

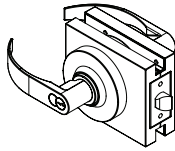

Locking with SFIC

Aluminum Framed Glass and Solid Door Levers

- For use with aluminum framed glass and solid doors.

Passage

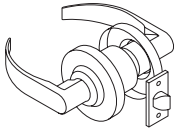

Locking

- Locking with SFIC
- Some manufacturers' cylinder-style locks can be used as a custom option.

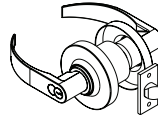

Door Stops

Cylindrical Door Stop

- Door stop is floor-mounted
- Height is 1½".

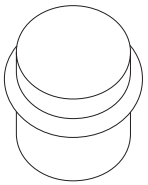

Dome Door Stop

- Door stop is floor-mounted
- Height is 1⅞" with optional spacer to increase height to 1½".

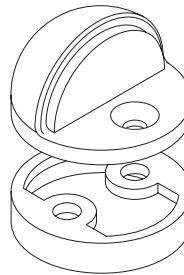

Magnetic Catch

- Painted to match trim finish. Specify Anodized Silver - PRO to coordinate with Clear, Anodized door frame.
- For use with center swing pivot frameless doors when specified with a pull.

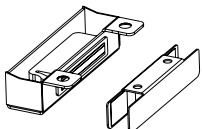

Thin Aluminum Framed Glass Levers

- For use with thin aluminum framed glass doors.

Cylindrical Style, Passage

- Non-locking
- Some manufacturers' cylinder-style levers can be specified as a custom option.

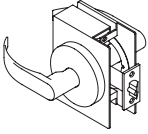

Cylindrical Style, Locking

- Locking with SFIC or locking with no core (coreless)
- Some manufacturers' cylinder-style locks can be specified as a custom option.

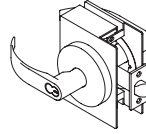

Mortise Style, Passage

- Non-locking

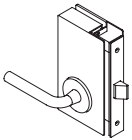

Mortise Style, Locking

- Locking with SFIC or locking less core (coreless)

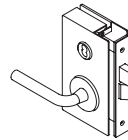

Mortise Style, Title 24, Passage

- Non-locking
- Title 24 compliant lever

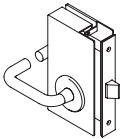

Mortise Style, Title 24, Locking

- Locking with SFIC or locking less core (coreless)
- Title 24 compliant lever

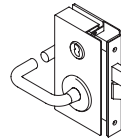

Thin Aluminum Framed Glass Hardware

- For use with thin aluminum framed glass doors.

Roller Latch

- For use with thin aluminum framed doors when specified with a pull.

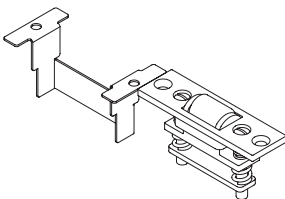

Thin Framed Swing Door Lock

- For use with thin aluminum framed doors when specified with a pull.

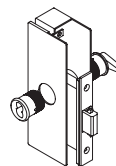

Ladder Pulls

- Use with all frameless glass and thin aluminum framed glass doors
- Use with sliding wood / aluminum framed glass doors

12"H Ladder Pull

- ¾" diameter pull
- Brushed stainless finish
- Passage only



12"H Value Ladder Pull

- 1" diameter pull
- Stainless steel finish
- Passage (non-locking) only

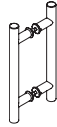

20"H Ladder Pull

- 1" diameter pull
- Anodized finish
- Passage only



49"H Ladder Pull

- 1 3/8" diameter pull
- Anodized finish
- Passage option
- Locking option
 - Thumb-turn deadbolt lock is received into a floor socket.
 - Rim cylinder with SFIC format
 - SFIC core for field-keying to building requirements
 - Best E keyway
 - Random keying
 - Use SFIC for any custom keying requirements.
 - LFIC and other RIM cylinders are available as a custom option.
 - Master keying is available by others.

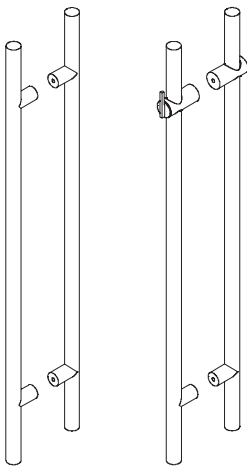

Passage

Locking with SFIC

60"H Ladder Pull

- 1 3/8" diameter pull
- Anodized finish
- Passage option
- Locking option
 - Thumb-turn deadbolt lock is received into a floor socket.
 - Rim cylinder with SFIC format
 - SFIC core for field-keying to building requirements
 - Best E keyway
 - Random keying
 - Use SFIC for any custom keying requirements.
 - LFIC and other RIM cylinders are available as a custom option.
 - Master keying is available by others.

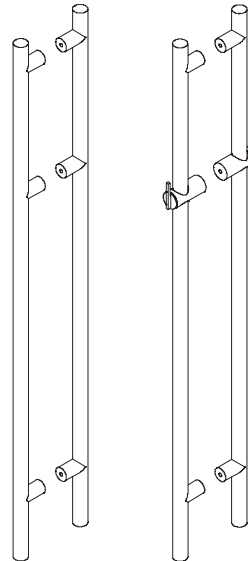

Passage

Locking with SFIC

Electronic Locking

The optional electronic locking feature on Beyond thin framed doors offers keyless entry and remote access when integrated with building security systems and/or electronic card readers.

- For use with Beyond thin framed glass sliding doors & hinge doors only.
- Locking mechanism includes electronic flushbolt with integrated position sensor and a 14' wire to provide power-access to locking mechanism on door.
 - Hinge door model also includes concealed door loop to pass wire between door & door frame
- Electronic lock is offered as either Failsafe or Failsecure function
 - Failsecure Operation: In the case of a power outage, door will automatically lock. Recommended for high security applications only.
 - Note: There is no override feature provided with this lock, additional power supply recommended for this application.
 - Failsafe Operation: In the case of a power outage, door will automatically unlock. Recommended for life safety applications.
- In hinged, single-door applications, electronic lock will mount into the vertical strike side of the door and locks into the door jamb.
- In hinged, double-door applications, electronic lock will mount into header of the door and lock into the header of the door frame.
- In all sliding door applications, the electronic lock will mount into the header of the door frame and locks into the header of the door.
 - When specifying electronic locking on a sliding door, please note that the glass offset must be towards the door frame.
- It is recommended that a low-voltage security installer is responsible for wiring & integration of lock with building security system. Work with project manager to coordinate installation. Please note that this model includes the locking mechanism and other accessories outlined above only. Allsteel does not provide the building security system, card-readers, or exit devices and these items must be sourced separately.

Finish options:

Silver (satin stainless steel US32D)

Black (oxidized black + lacquer US19)

Manufactured by SDC

Accessibility Ladder Pulls

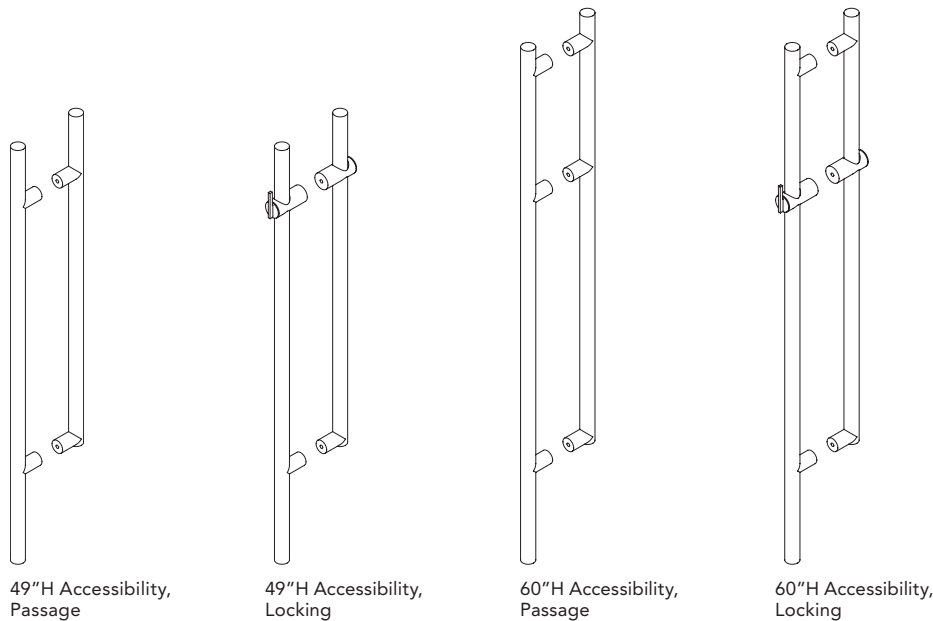

49”H Accessibility, Passage

49”H Accessibility, Locking

60”H Accessibility, Passage

60”H Accessibility, Locking

Accessibility ladder pulls are offered as a solution where required for ADA.

- Accessibility ladder pulls feature an asymmetrical design where the bottom of the ladder pull aligns with the bottom of the door on one side of the door but does not extend down to the bottom of the door on the opposite side.
- The thin frame door leaf has also been designed with an offset glass feature, designed to create a smooth surface on one side of the door with an offset on the opposite side of the door.
 - In swing-door applications, the smooth side of the glass offset will always be on the push side of the door.
- Although this product has been designed with input from ADA, Allsteel is not certified or licensed to enforce building code and it is the responsibility of the specifiers, architect, and/or design firm to ultimately ensure that the way that the product is being used or specified will meet local and state building codes within that specific jurisdiction.

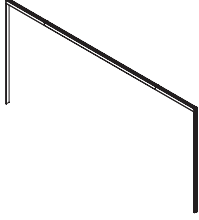

Base Model	Description	Specification
BY-FSFREEWAY	Freestanding Freeway Opening	BY-FSFREEWAY

Configuration ID	Specification Description
Product	Beyond Freestanding
Width	39"-216"W in ¼" Increments
Height	86"-120"H in ¼" Increments
Frame Finish	Painted or Anodized Finishes

Option	Specification Description	Specification
Paint Color Selection	3-digit painted or anodized finish	See Beyond Frame Finishes

Specification Example: **BY-FSFREEWAY.####.P8X**

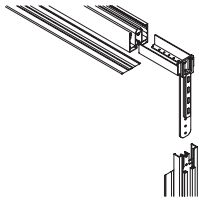

Base Model	Description	Specification
BY-FREEWAYBRK	Freestanding Freeway Support Bracket	BY-FREEWAYBRK

Configuration ID	Specification Description
Product	Beyond Freestanding
Door Module	Single or Double

Specification Example: **BY-FREEWAYBRK.####**

Sliding Doors

Beyond® — Frameless Sliding Door & Bottom Seal

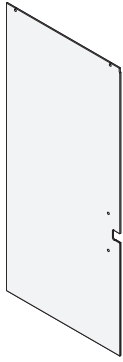

Single, Full Strike Locking

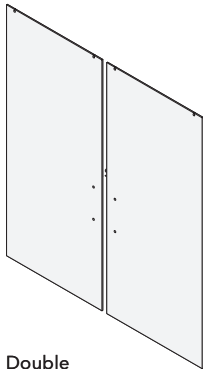

Double

Base Model	Description	Specification
BY-FGSDLEAF	Frameless Glass Sliding Door Leaf	BY-FGSDLEAF
Configuration ID	Specification Description	
Product	Beyond	
Width	42" - Single Door 78" - Double Door	
Height	86" - 120" in 1/4" increments 85" only - Single 7'H with Transom	
Strike Style	Field will populate if full strike is selected Full Strike Full Strike Locking	
Door Type	Sliding	
Door Style	Frameless Glass	
Door Module	Single	
Transom	Double (Note: Order QTY 2 doors for double door application) Field will populate if 85"H single door is selected Yes No	
Handle Type	Ladder Pull	
Ladder Pull Options	Height 12" Value 20" 49" Passage 49" Accessibility and/or Locking 60" Passage 60" Accessibility and/or Locking	Ladder Pull Placement Options Justified to Strike Only Justified to Strike Only Can be Justified to Bottom, Center, Strike, or Top Justified to Bottom Only Can be Justified to Bottom, Center, Strike, or Top Justified to Bottom Only
Floor Treatment	Will populate if footer or drop seal is selected: Footer	
Glass Code	See below for glass finish options	

Option	Specification Description	Specification
Glass Selection	TA: 3/8" Tempered, Clear	
	TB: 3/8" Tempered, Low Iron	See Beyond Frame Finishes

Specification Example: **BY-FGSDLEAF.####.TA**

Note: If Enhanced Acoustics is selected for a frameless door, it will not appear notated on the door model.

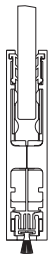

Footer

Base Model	Description	Specification
BY-FGSDFOOTER	Frameless Glass Sliding Door Bottom Seal	BY-FGSDFOOTER
Configuration ID	Specification Description	
Product	Beyond	
Dimension	42"	
Trim Type	Door Apron	
Trim Use	Strike Universal	
Trim Style	Will populate if drop seal is selected: Drop Seal	
Finish Color	Painted or Anodized Finishes	

Option	Specification Description	Specification
Paint Color Selection	3-digit painted or anodized finish	See Beyond Frame Finishes

Specification Example: **BY-FGSDFOOTER.####.P8X**

Sliding Doors

Beyond® — Thin Aluminum Framed Sliding Door Leaf

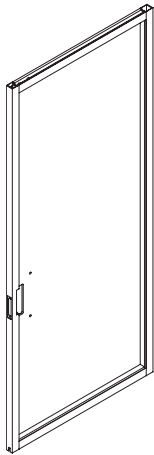

Thin Aluminum Framed Glass Sliding, Single

Base Model	Description	Specification
BY-TALSDLEAF	Thin Aluminum Framed Glass Sliding Door Leaf	BY-TALSDLEAF
Configuration ID	Specification Description	Specification
Product	Beyond	
Width	42" or 48" - Single Door 78" - Double Door	
Height	86" - 120" up to 42"W in ¼" increments 86" - 108¾" up to 48"W in ¼" increments 85" only - Single 7'H with Transom	
Strike Style	<i>Field will populate if full strike is selected</i> Full Strike Full Strike Locking (Note: Must be selected for jamb locking)	
Door Type	Sliding	
Door Style	Thin Aluminum Framed	
Door Module	Single Double (Note: If locking, order QTY 1 active door and QTY 1 inactive door for double door application)	
Transom	<i>Field will populate if 85"H single door is selected</i> Yes No	
Hand	Left Right	
Leaf Type	<i>Field will populate if double is selected</i> Active Inactive (When Locked)	
Glass Offset	Glass Offset Towards Door Frame Glass Offset Away from Door Frame	
Handle Type	Ladder Pull	
Ladder Pull Options	Height 12" Value 20" 49" Passage 49" Accessibility and/or Locking 60" Passage 60" Accessibility and/or Locking	Ladder Pull Placement Options Justified to Strike Only Justified to Strike Only Can be Justified to Bottom, Center, Strike, or Top Justified to Bottom Only Can be Justified to Bottom, Center, Strike, or Top Justified to Bottom Only
Lock Style	Passage or Floor-Locking Mortise (Note: Only active door will have mortise patch housing)	
Electronic Lock Style	Electronic Locking No Electronic Locking	
Glass Code	See below for glass finish options	
Aluminum Rail Finish	See Beyond Frame Finishes	
Option	Specification Description	Specification
Glass Selection	TA: ⅜" Tempered, Clear TB: ⅜" Tempered, Low Iron	
Paint Color Selection	3-digit painted or anodized finish	See Beyond Frame Finishes

Specification Example: BY-TALSDLEAF.####.TA.P8X

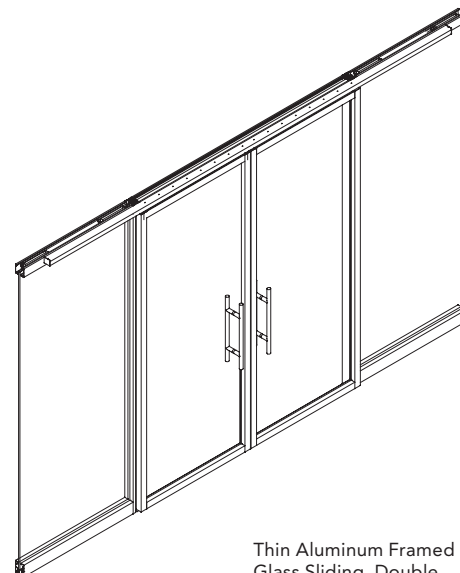

Thin Aluminum Framed Glass Sliding, Double



Single, Full Strike Locking

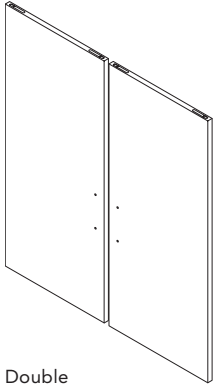

Double

Base Model	Description	Specification
BY-SLDSLEAF	Solid Sliding Door Leaf	BY-SLDSLEAF
Configuration ID	Specification Description	
Product	Beyond	
Width	42" or 48" - Single Door 78" - Double Door	
Height	86" - 120" up to 42"W in ¼" increments 86" - 108¾" up to 48"W in ¼" increments 85" only - Single 7'H with Transom	
Strike Style	Field will populate if full strike is selected Full Strike Full Strike Locking	
Door Type	Sliding	
Door Style	Wood	
Door Module	Single Double (Note: Order QTY 2 doors for double door application)	
Transom	Field will populate if 85"H single door is selected Yes No	
Handle Type	Ladder Pull	
Ladder Pull Options	Height 12" Value 20" 49" Passage 49" Accessibility and/or Locking 60" Passage 60" Accessibility and/or Locking	Ladder Pull Placement Options Justified to Strike Only Justified to Strike Only Can be Justified to Bottom, Center, Strike, or Top Justified to Bottom Only Can be Justified to Bottom, Center, Strike, or Top Justified to Bottom Only
FSC	FSC Certified Not FSC Certified	FSC X
Finish	See below	

Option	Specification Description	Specification
FSC Option	FSC Certified Standard Wood (Not FSC Certified)	FSC X
Material Grade and Color Option	Veneer - See Beyond Veneer Finishes Laminate - See Beyond Laminate Finishes Painted Wood - See Beyond Painted Wood Finishes	

Specification Example: BY-SLDSLEAF.####.X.LWC

Note: If Enhanced Acoustics is selected for a solid door, it will not appear notated on the door model.

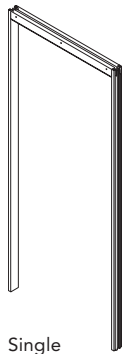

Single

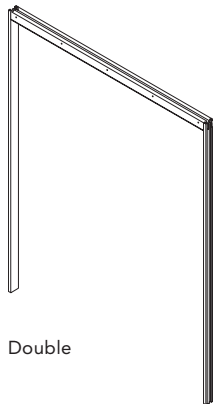

Double

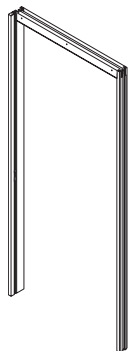

Single, Full Strike, Frameless Glass

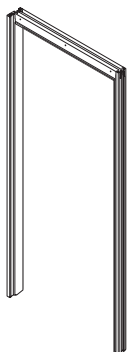

Single, Full Strike, Aluminum Framed Glass/Solid

Base Model	Description	Specification
BY-SDFRAME	Sliding Door Frame	BY-SDFRAME
Configuration ID	Specification Description	
Product	Beyond	
Width	42" - Single Door 48" - Single Door 78" - Double Door	
Height	86"-120" in ¼" increments	
Strike Style	<i>Will populate if full strike is selected on single doors</i> Full Strike Full Strike Jamb Locking	
Door Type	Sliding	
Door Style	Frameless Glass Wood or Aluminum Framed Thin Aluminum Framed	
Door Module	Single Double	
Enhanced Acoustic	<i>Will populate if frameless, wood, or aluminum framed is selected</i> Standard Enhanced	
Hand	<i>Will populate if full strike or thin aluminum framed glass is selected</i> Left Right	
Lock Style	Passage or Floor-Locking Mortise (Note: Only active door will have mortise patch housing)	
Electronic Lock Style	Electronic Locking No Electronic Locking	
Frame Finish	Painted or Anodized Finishes	
Option	Specification Description	Specification
Paint Color Selection	3-digit painted or anodized finish	See Beyond Frame Finishes

Specification Example: BY-SDFRAME.####.P8X

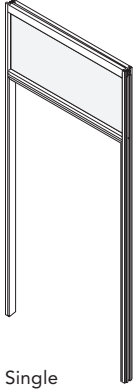

Base Model	Description	Specification
BY-SDFRAMEGLTR	Sliding Door Frame with Transom	BY-SDFRAMEGLTR

Configuration ID	Specification Description
Product	Beyond
Width	42-0" - 48-0"
Height	96-0" - 120-0" in ¼" increments - Nominal height from top of transom to finished floor
Transom Height	10¾" - 37¾" in ¼" increments
Door Type	7'H with Transom Sliding
Door Style	Frameless Glass Wood or 5" Aluminum Framed 2" Thin Aluminum Framed
Door Module	Single
Enhanced Acoustic	Standard Enhanced
Hand	Will populate if thin aluminum framed glass is selected Left Right
Glass Code	See options below
Frame Finish	See options below

Option	Specification Description	Specification
Glass Selection	QA: ¼" Tempered, Clear	See Beyond Frame Finishes
	QB: ¼" Tempered, Low Iron	
	QC: ¼" Laminated, Clear	
	QD: ¼" Laminated, Low Iron	
	QE: ¼" Laminated, Clear, Translucent White	
	QF: ¼" Laminated, Low Iron, Markerboard	
	QG: ¼" Laminated, High Performance, Clear	
	QH: ¼" Laminated, High Performance, Low Iron	
	QL: ¼" Laminated, Clear, Markerboard	
	TA: ⅜" Tempered, Clear	
	TB: ⅜" Tempered, Low Iron	
	TC: ⅜" Laminated, Clear	
	TD: ⅜" Laminated, Low Iron	
	TE: ⅜" Laminated, Clear, Translucent White	
	TF: ⅜" Laminated, Low Iron, Markerboard	
TG: ⅜" Laminated, High Performance, Clear		
TH: ⅜" Laminated, High Performance, Low Iron		
TL: ⅜" Laminated, Clear, Markerboard		
TN: ⅜" Back-to-Back Back-Painted, Low Iron, Turquoise		
TP: ⅜" Back-to-Back Back-Painted, Low Iron, Cherry		
TQ: ⅜" Back-to-Back Back-Painted, Low Iron, Lawn		
TR: ⅜" Back-to-Back Back-Painted, Low Iron, Jet		
TS: ⅜" Back-to-Back Back-Painted, Low Iron, Mandarin		
Paint Color Selection	3-digit painted or anodized finish	See Beyond Frame Finishes

Specification Example: BY-SDFRAMEGLTR.#####.QA.P8X



Trailing Edge Seal

Base Model	Description	Specification
BY-FGTRAILINGSEAL	Frameless Glass Door Trailing Edge Seal	BY-FGTRAILINGSEAL

Specification Example: BY-FGTRAILINGSEAL

BEYOND TABLE OF CONTENTS
BEYOND FINISHES & FABRICS
BEYOND PANELS & TRIM
BEYOND DOORS
BEYOND CONNECTORS
BEYOND ELECTRICAL & DATA
BEYOND FRAMELESS PRIVACY TILE SYSTEM
BEYOND VIZ

Base Model	Description	Specification
BY-SDTRACK	Sliding Door Track	BY-SDTRACK

Configuration ID	Specification Description
Product	Beyond Track
Width	42" or 48" - Single Door 78" - Double Door
Strike Style	<i>Will populate if full strike is selected on single doors</i> Full Strike
Door Type	Sliding 7'H with Transom Sliding
Door Style	Frameless Glass Wood or Aluminum Framed Thin Aluminum Framed
Door Module	Single Double
Enhanced Acoustic	<i>Will populate if frameless, wood, or aluminum framed is selected</i> Standard Enhanced
Hand	<i>Will populate if thin aluminum framed is selected</i> Left Right
Closer	<i>Will populate if slow close is selected:</i> Sliding Slow Close
Frame Finish	Painted or Anodized Finishes

Option	Specification Description	Specification
Paint Color Selection	3-digit painted or anodized finish	See Beyond Frame Finishes

Specification Example: BY-SDTRACK.####.P8X

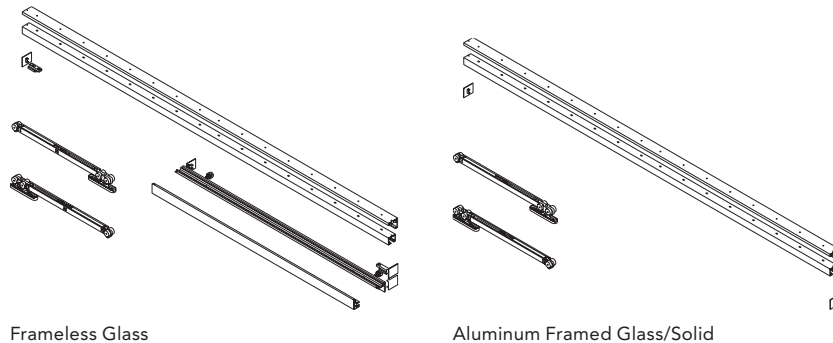

Base Model	Description	Specification
BY-SDMOUNT	Frameless Glass Panel Sliding Door Mount	BY-SDMOUNT

Option	Specification Description	Specification
Quantity	Single Double	S D

Specification Example: BY-SDMOUNT.S

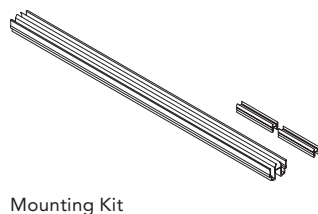

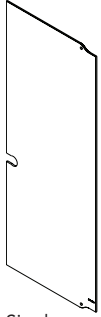

Single

Base Model	Description	Specification
BY-FGPDLEAF	Frameless Glass Pivot Door Leaf	BY-FGPDLEAF
Configuration ID	Specification Description	
Product	Beyond	
Width	39-0"	
Height	86-0"-120-0" in 1/4" increments	
Strike Style	Partial	
Door Type	Pivot	
Door Style	Frameless Glass	
Door Module	Single	
Handle Type	Cylindrical Lever Ladder Pull	
Ladder Pull Options	Field will populate if Ladder Pull is selected	
	Height 12" Value 20" 49" Passage 49" Accessibility and/or Locking 60" Passage 60" Accessibility and/or Locking	Ladder Pull Placement Options Justified to Strike Only Justified to Strike Only Can be Justified to Bottom, Center, Strike, or Top Justified to Bottom Only Can be Justified to Bottom, Center, Strike, or Top Justified to Bottom Only
Glass Code	See below for glass finish options	
Option	Specification Description	Specification
Glass Selection	HA: 1/2" Tempered, Clear HB: 1/2" Tempered, Low Iron	

Specification Example: BY-FGSDLEAF.####.TA

BEYOND
TABLE OF CONTENTS

BEYOND
FINISHES & FABRICS

BEYOND
PANELS & TRIM

BEYOND
DOORS

BEYOND
CONNECTORS

BEYOND
ELECTRICAL & DATA

BEYOND
FRAMELESS PRIVACY
TILE SYSTEM

BEYOND
VIZ

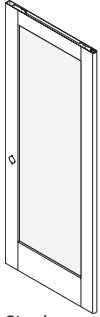

Single

Base Model	Description	Specification
BY-ALPDLEAF	Aluminum Framed Glass Pivot Door Leaf	BY-ALPDLEAF
Configuration ID	Specification Description	
Product	Beyond	
Width	39"	
Height	86"-120" in ¼" increments	
Strike Style	Partial	
Door Type	Pivot	
Door Style	Aluminum 5in Base Aluminum 10in Base	
Door Module	Single	
Handle Type	Ladder Pull Cylindrical Lever	
Ladder Pull Options	<i>Field will populate if Ladder Pull is selected</i>	
	Height 12" Value 20" 49" Passage 49" Accessibility and/or Locking 60" Passage 60" Accessibility and/or Locking	Ladder Pull Placement Options Justified to Strike Only Justified to Strike Only Can be Justified to Bottom, Center, Strike, or Top Justified to Bottom Only Can be Justified to Bottom, Center, Strike, or Top Justified to Bottom Only
Header Style	<i>Will populate if Ladder Pull is selected</i>	
	Roller Latch	
Glass Code	See below for glass finish options	
Frame Finish	See Beyond Frame Finishes	
Option	Specification Description	Specification
Glass Selection	QA: ¼" Tempered, Clear	
	QB: ¼" Tempered, Low Iron	
	QC: ¼" Laminated, Clear	
	QD: ¼" Laminated, Low Iron	
	QE: ¼" Laminated, Clear, Translucent White	
	QF: ¼" Laminated, Low Iron, Markerboard	
	QG: ¼" Laminated, High Performance, Clear	
	QH: ¼" Laminated, High Performance, Low Iron	
	QL: ¼" Laminated, Clear, Markerboard	
	TA: ⅜" Tempered, Clear	
	TB: ⅜" Tempered, Low Iron	
	TC: ⅜" Laminated, Clear	
	TD: ⅜" Laminated, Low Iron	
	TE: ⅜" Laminated, Clear, Translucent White	
	TF: ⅜" Laminated, Low Iron, Markerboard	
	TG: ⅜" Laminated, High Performance, Clear	
	TH: ⅜" Laminated, High Performance, Low Iron	
	TL: ⅜" Laminated, Clear, Markerboard	
TN: ⅜" Back-to-Back Back-Painted, Low Iron, Turquoise		
TP: ⅜" Back-to-Back Back-Painted, Low Iron, Cherry		
TQ: ⅜" Back-to-Back Back-Painted, Low Iron, Lawn		
TR: ⅜" Back-to-Back Back-Painted, Low Iron, Jet		
TS: ⅜" Back-to-Back Back-Painted, Low Iron, Mandarin		
Paint Color Selection	3-digit painted or anodized finish	See Beyond Frame Finishes

Specification Example: BY-ALPDLEAF.####.QA.P8X

Pivot Doors

Beyond® — Thin Aluminum Framed Pivot Door Leaf

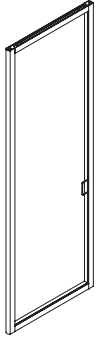

Thin Aluminum Framed Glass Pivot, Single

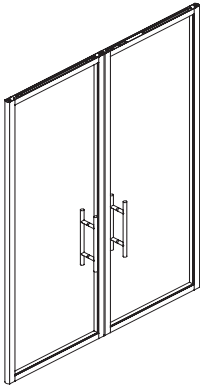

Thin Aluminum Framed Glass Pivot, Double

Base Model	Description	Specification
BY-TALPDLEAF	Thin Aluminum Framed Glass Pivot Door Leaf	BY-TALPDLEAF
Configuration ID	Specification Description	
Product	Beyond	
Width	39" - Single Door 75" - Double Door	
Height	86"-120" in ¼" increments	
Strike Style	<i>Field will populate if lever is selected</i> Partial Strike <i>Field will populate if Ladder Pull is selected</i> None	
Door Type	Pivot	
Door Style	Thin Aluminum Framed	
Door Module	Single Double (Note: Order QTY 2 doors for double door application)	
Hand	Left Right	
Leaf Type	<i>Field will populate if double is selected</i> Active Inactive	
Lock Style	Passage Mechanical	
Handle Type	Ladder Pull Cylindrical Lever	
Ladder Pull Options	<i>Field will populate if Ladder Pull is selected</i> Height 12" Value 20" 49" Passage 49" Accessibility and/or Locking 60" Passage 60" Accessibility and/or Locking Ladder Pull Placement Options Justified to Strike Only Justified to Strike Only Can be Justified to Bottom, Center, Strike, or Top Justified to Bottom Only Can be Justified to Bottom, Center, Strike, or Top Justified to Bottom Only	
Header Style	<i>Will populate if Ladder Pull is selected</i> Roller Latch	
Glass Code	See below for glass finish options	
Aluminum Rail Finish	See Beyond Frame Finishes	
Option	Specification Description	Specification
Glass Selection	TA: ¾" Tempered, Clear TB: ¾" Tempered, Low Iron	
Paint Color Selection	3-digit painted or anodized finish	See Beyond Frame Finishes
<i>Specification Example: BY-TALPDLEAF.####.TA.P8X</i>		

BEYOND TABLE OF CONTENTS
 BEYOND FINISHES & FABRICS
 BEYOND PANELS & TRIM
 BEYOND DOORS
 BEYOND CONNECTORS
 BEYOND ELECTRICAL & DATA
 BEYOND FRAMELESS PRIVACY TILE SYSTEM
 BEYOND VIZ

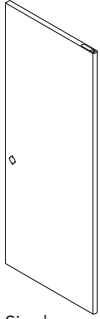

Single

Base Model	Description	Specification
BY-SLDPDLEAF	Solid Pivot Door Leaf	BY-SLDPDLEAF
Configuration ID	Specification Description	
Product	Beyond	
Width	39"	
Height	86"-120" in ¼" increments	
Strike Style	Partial	
Door Type	Pivot	
Door Style	Wood	
Door Module	Single	
Handle Type	Ladder Pull Cylindrical Lever	
Ladder Pull Options	<i>Field will populate if Ladder Pull is selected</i>	
	Height 12" Value 20" 49" Passage 49" Accessibility and/or Locking 60" Passage 60" Accessibility and/or Locking	Ladder Pull Placement Options Justified to Strike Only Justified to Strike Only Can be Justified to Bottom, Center, Strike, or Top Justified to Bottom Only Can be Justified to Bottom, Center, Strike, or Top Justified to Bottom Only
Header Style	<i>Will populate if Ladder Pull is selected</i> Roller Latch	
FSC	FSC Certified Not FSC Certified	FSC X
Finish	See finish options below	
Option	Specification Description	Specification
FSC Option	FSC Certified Standard Wood (Not FSC Certified)	FSC X
Material Grade and Color Option	Veneer - See Beyond Veneer Finishes Laminate - See Beyond Laminate Finishes Painted Wood - See Beyond Painted Wood Finishes	

Specification Example: BY-SLDPDLEAF.###.LWC



Single

Base Model	Description	Specification
BY-PDFRAME	Pivot Door Frame	BY-PDFRAME
Configuration ID	Specification Description	
Product	Beyond	
Width	39"	
Height	86"-120" in ¼" increments	
Strike Style	<i>Will populate if aluminum framed door with lever is selected</i> Partial <i>Will populate if thin aluminum framed door with Ladder Pull and lock is selected</i> Full Strike, Jamb Locking <i>Will populate if thin aluminum framed door with lever is selected</i> Full Strike, Cylindrical Lever Full Strike, Mortise Lever	
Door Type	Pivot	
Door Style	Frameless Glass Wood or Aluminum Thin Aluminum Framed	
Door Module	Single Double	
Enhanced Acoustic	Standard Enhanced	
Hand	<i>Will populate if thin aluminum framed door is selected</i> Left Right	
Lock Style	<i>Will populate if thin aluminum framed door is selected</i> Mortise Lever Cylindrical Lever Passage or Floor-Locking	
Frame Finish	Painted or Anodized Finishes	
Option	Specification Description	Specification
Paint Color Selection	3-digit painted or anodized finish	See Beyond Frame Finishes

Specification Example: BY-PDFRAME.###.P8X

Pivot Doors

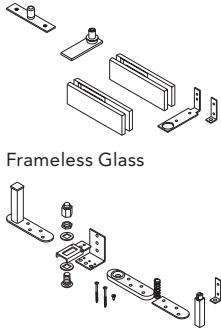

Frameless Glass

Aluminum Framed Glass/Solid

Option	Specification Description	Specification
BY-PIVOTMOUNT	Pivot Mount - Single Door	BY-PIVOTMOUNT

Option	Specification Description	Specification
Door Material	Frameless Glass	FG
	Aluminum-Framed/Wood	AL-WD
Trim Color	3-digit finish selection	See Beyond Hardware Finishes

Specification Example: BY-PIVOTMOUNT.FG.SIL

Base Model	Description	Specification
BY-PIVOT	Pivot Mount	BY-PIVOT

Option	Specification Description	Specification
Hinge Configuration	Single	S
	Double	D
Door	Thin Aluminum Framed	TAF
Trim Color	3-digit finish code	See Beyond Hardware Finishes

Specification Example: BY-PIVOT.S.TAF.P8X

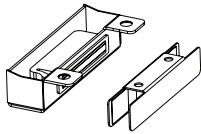

Magnetic Catch

Base Model	Description	Specification
BY-MAGCATCH	Magnetic Catch	BY-MAGCATCH

Option	Specification Description	Specification
Paint Color Selection	3-digit finish code	See: Beyond Painted Finish Options

Specification Example: BY-MAGCATCH.P8X

Note: Specify Anodized Silver - PR0 to coordinate with Clear, Anodized frame.

BEYOND PIVOT MOUNTS
 BEYOND FINISHES & FABRICS
 BEYOND PANELS & TRIM
 BEYOND DOORS
 BEYOND CONNECTORS
 BEYOND ELECTRICAL & DATA
 BEYOND FRAMELESS PRIVACY TILE SYSTEM
 BEYOND VIZ

Hinged Doors

Beyond® — Frameless Hinged Door



Single

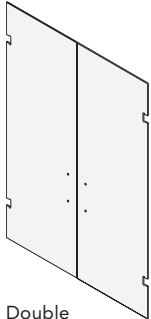

Double

Base Model	Description	Specification
BY-FGHDLEAF	Frameless Glass Hinged Door Leaf	BY-FGHDLEAF
Configuration ID	Specification Description	
Product	Beyond	
Width	39" - Single Door 75" - Double Door	
Height	86"-120" in ¼" increments	
Door Type	Hinged	
Door Style	Frameless Glass	
Door Module	Single	
Handle Type	Ladder Pull	
Ladder Pull Options	<i>Field will populate if Ladder Pull is selected</i>	
	Height 12" Value 20" 49" Passage 49" ADA and/or Locking 60" Passage 60" ADA and/or Locking	Ladder Pull Placement Options Justified to Strike Only Justified to Strike Only Can be Justified to Bottom, Center, Strike, or Top Justified to Bottom Only Can be Justified to Bottom, Center, Strike, or Top Justified to Bottom Only
Glass Code	See Finish Options below	
Option	Specification Description	Specification
Glass Selection	HA: ½" Tempered, Clear	HA
	HB: ½" Tempered, Low Iron	HB

Specification Example: BY-FGHDLEAF.####.HA

Hinged Doors

Beyond® — Aluminum Framed Glass Hinged Door

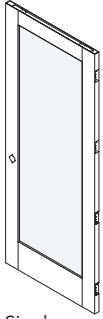

Single

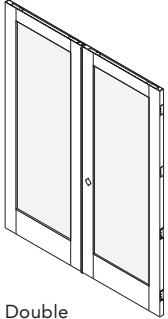

Double

Base Model	Description	Specification
BY-ALHDLEAF	Aluminum Framed Glass Hinged Door Leaf	BY-ALHDLEAF
Configuration ID	Specification Description	
Product	Beyond	
Width	39" - Single Door 75" - Double Door	
Height	86"-120" in 1/4" increments	
Door Type	Hinged	
Door Style	Aluminum 5in Base Aluminum 10in Base	
Door Module	Single Double (Note: Order QTY 1 active door and QTY 1 inactive door for double door application)	
Hand	Left Right	
Leaf Type	Will populate if double door is selected Active Inactive	
Handle Type	Ladder Pull Cylindrical Lever	
Ladder Pull Options	<i>Field will populate if Ladder Pull is selected</i>	
	Height 12" Value 20" 49" Passage 49" ADA and/or Locking 60" Passage 60" ADA and/or Locking	Ladder Pull Placement Options Justified to Strike Only Justified to Strike Only Can be Justified to Bottom, Center, Strike, or Top Justified to Bottom Only Can be Justified to Bottom, Center, Strike, or Top Justified to Bottom Only
Closure Style	<i>Will populate if Ladder Pull is selected</i> Roller Latch No Latch (Self-Closing Hinges) <i>Will populate if a lever is selected</i> Lever Latch	
Glass Code	See Finish Options below	
Aluminum Rail Finish	See Beyond Frame Finishes	
Option	Specification Description	Specification
Glass Selection	QA: 1/4" Tempered, Clear QB: 1/4" Tempered, Low Iron QC: 1/4" Laminated, Clear QD: 1/4" Laminated, Low Iron QE: 1/4" Laminated, Clear, Translucent White QF: 1/4" Laminated, Low Iron, Markerboard QG: 1/4" Laminated, High Performance, Clear QH: 1/4" Laminated, High Performance, Low Iron QL: 1/4" Laminated, Clear, Markerboard TA: 3/8" Tempered, Clear TB: 3/8" Tempered, Low Iron TC: 3/8" Laminated, Clear TD: 3/8" Laminated, Low Iron TE: 3/8" Laminated, Clear, Translucent White TF: 3/8" Laminated, Low Iron, Markerboard TG: 3/8" Laminated, High Performance, Clear TH: 3/8" Laminated, High Performance, Low Iron TL: 3/8" Laminated, Clear, Markerboard TN: 3/8" Back-to-Back Back-Painted, Low Iron, Turquoise TP: 3/8" Back-to-Back Back-Painted, Low Iron, Cherry TQ: 3/8" Back-to-Back Back-Painted, Low Iron, Lawn TR: 3/8" Back-to-Back Back-Painted, Low Iron, Jet TS: 3/8" Back-to-Back Back-Painted, Low Iron, Mandarin	
Paint Color Selection	3-digit painted or anodized finish	See Beyond Frame Finishes

Specification Example: BY-ALHDLEAF.####.QA.P8X

Hinged Doors

Beyond® — Thin Aluminum Framed Glass Hinged Door

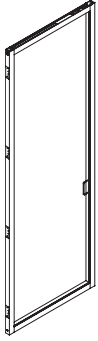

Thin Aluminum Framed Glass Sliding, Single

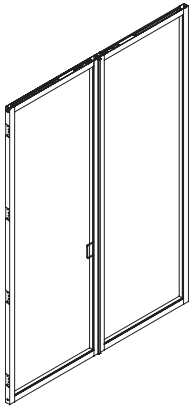

Thin Aluminum Framed Glass Sliding, Double

Base Model	Description	Specification
BY-TALHDLEAF	Thin Aluminum Framed Glass Hinged Door Leaf	BY-TALHDLEAF
Configuration ID	Specification Description	
Product	Beyond	
Width	39" - Single Door 75" - Double Door	
Height	86"-120" up to 42"W in ¼" increments	
Strike Style	Full Strike	
Door Type	Hinged	
Door Style	Thin Aluminum Framed	
Door Module	Single	
	Double (Note: If adjacent door-locking, order QTY 1 active door and QTY 1 inactive door for double door application. If passage or floor-locking, order QTY 2 active door.)	
Hand	Left Right	
Leaf Type	<i>Field will populate if double is selected</i> Active Inactive	
Handle Type	Ladder Pull Cylindrical Lever Mortise Lever	
Ladder Pull Options	<i>Field will populate if Ladder Pull is selected</i> Height 12" Value 20" 49" Passage 49" ADA and/or Locking 60" Passage 60" ADA and/or Locking	
	Ladder Pull Placement Options Justified to Strike Only Justified to Strike Only Can be Justified to Bottom, Center, Strike, or Top Justified to Bottom Only Can be Justified to Bottom, Center, Strike, or Top Justified to Bottom Only	
Closure Style	<i>Will populate if Ladder Pull is selected</i> Roller Latch No Latch (Self-Closing Hinges) <i>Will populate if a lever is selected</i> Lever Latch	
Floor Treatment	Drop Seal	
Lock Style	<i>Field will populate if Ladder Pull is selected</i> Passage or Floor-Locking Mortise	
Electronic Lock Style	Electronic Locking No Electronic Locking	
Glass Code	See below for glass finish options	
Aluminum Rail Finish	See Beyond Frame Finishes	
Option	Specification Description	Specification
Glass Selection	TA: ¾" Tempered, Clear TB: ¾" Tempered, Low Iron	
Paint Color Selection	3-digit painted or anodized finish	See Beyond Frame Finishes

Specification Example: BY-TALHDLEAF.####.TA.P8X

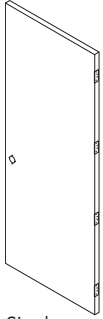

Single

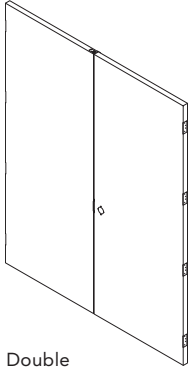

Double

Base Model	Description	Specification
BY-SLDHDLEAF	Solid Hinged Door Leaf	BY-SLDHDLEAF
Configuration ID	Specification Description	
Product	Beyond	
Width	39" - Single Door 75" - Double Door	
Height	86"-120" in ¼" increments	
Door Type	Hinged	
Door Style	Wood	
Door Module	Single	
	Double (Note: Order QTY 1 active door and QTY 1 inactive door for double door application)	
Hand	Left Right	
Leaf Type	Will populate if double door is selected Active Inactive	
Handle Type	Ladder Pull Cylindrical Lever	
Ladder Pull Options	<i>Field will populate if Ladder Pull is selected</i>	
	Height 12" Value 20" 49" Passage 49" ADA and/or Locking 60" Passage 60" ADA and/or Locking	Ladder Pull Placement Options Justified to Strike Only Justified to Strike Only Can be Justified to Bottom, Center, Strike, or Top Justified to Bottom Only Can be Justified to Bottom, Center, Strike, or Top Justified to Bottom Only
Closure Style	<i>Will populate if Ladder Pull is selected</i> Roller Latch No Latch (Self-Closing Hinges) <i>Will populate if a lever is selected</i> Lever Latch	
Floor Treatment	Will populate if drop seal is selected Drop Seal	
FSC	FSC Certified Not FSC Certified	FSC X
Finish	See finish options below	
Option	Specification Description	Specification
FSC Option	FSC Certified Standard Wood (Not FSC Certified)	FSC X
Material Grade and Color Option	Veneer - See Beyond Veneer Finishes Laminate - See Beyond Laminate Finishes Painted Wood - See Beyond Painted Wood Finishes	

Specification Example: BY-SLDHDLEAF.####.FSC.LWC

Hinged Doors

Beyond® — Hinged Door Frame

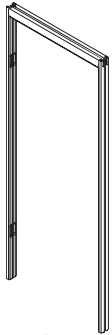

Single,
Frameless Glass

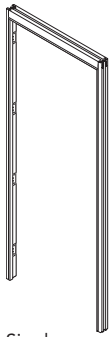

Single,
Aluminum Framed
Glass/Solid

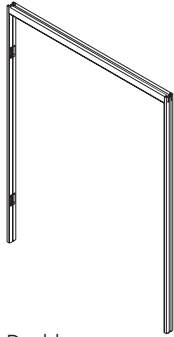

Double,
Frameless Glass

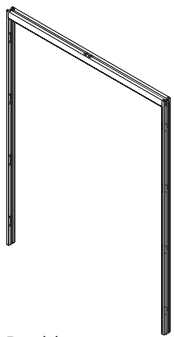

Double,
Aluminum Framed
Glass/Solid

Base Model	Description	Specification
BY-HDFRAME	Hinged Door Frame	BY-HDFRAME
Configuration ID	Specification Description	Specification
Product	Beyond	
Width	39" - Single Door 75" - Double Door	
Height	86"-120" in ¼" increments	
Strike Style	<i>Will populate if wood or aluminum framed door is selected</i> Full Strike <i>Will populate if thin aluminum framed with Ladder Pull and lock is selected</i> Full Strike, Jamb Locking <i>Will populate if thin aluminum framed with lever is selected</i> Full Strike, Cylindrical Lever Full Strike, Mortise Lever	
Door Type	Hinged	
Door Style	Frameless Glass Wood or Aluminum Thin Aluminum Framed	
Door Module	Single Double	
Enhanced Acoustic	Standard Enhanced	
Hand	<i>Will populate if wood, aluminum framed, or thin aluminum framed door is selected</i> Left Right	
Lock Style	<i>Will populate if thin aluminum framed door is selected</i> Lever Mortise Mortise Lever Passage or Floor-Locking	
Electronic Lock Style	<i>Will populate if thin aluminum framed door is selected</i> Electronic Locking No Electronic Locking	
Frame Finish	Painted or Anodized Finishes	
Option	Specification Description	Specification
Paint Color Selection	3-digit painted or anodized finish	See Beyond Frame Finishes

Specification Example: BY-HDFRAME.####.P8X

BEYOND TABLE OF CONTENTS BEYOND FINISHES & FABRICS BEYOND PANELS & TRIM BEYOND DOORS BEYOND CONNECTORS BEYOND ELECTRICAL & DATA BEYOND FRAMELESS PRIVACY TILE SYSTEM BEYOND VIZ

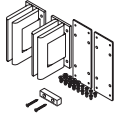

Glass

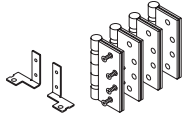

Aluminum Framed Glass/Solid

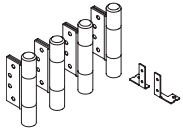

Self-Closing Hinges

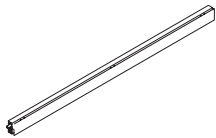

Drop Seal

Base Model	Description	Specification
BY-HINGEDMOUNT	Hinged Door Mounting Hardware	BY-HINGEDMOUNT

Option	Specification Description	Specification
Hinge Configuration	Single	S
	Double	D
Type/Functionality	Frameless Glass	FGCLSR
	Aluminum Framed/Wood	AL-WDNCSR
Trim Color	3-digit finish code	See Beyond Hardware Finishes

Specification Example: BY-HINGEDMOUNT.SAL-WDNCSR.SIL

Base Model	Description	Specification
BY-HINGEDMOUNTCLSR	Self-Closing Hinges	BY-HINGEDMOUNTCLSR

Option	Specification Description	Specification
Trim Color	3-digit finish code	See Beyond Hardware Finishes
Hinge Configuration	Single	S
	Double	D
Type/Functionality	Aluminum Framed/Wood	AL-WD

Specification Example: BY-HINGEDMOUNTCLSR.SIL.S.AL-WD

Base Model	Description	Specification
BY-SLDBTMSEAL	Aluminum/Solid Hinged Door Bottom Seal	BY-SLDBTMSEAL

Specification Example: BY-SLDBTMSEAL



12"

Base Model	Description	Specification
BY-PULL12	12" Ladder Pull	BY-PULL12
Option	Specification	Description
Door Material	Frameless Glass	FG
	Aluminum-Framed/Wood	AL-WD
Trim Color	3-digit finish code	See Beyond Hardware Finishes

Specification Example: **BY-PULL12.FG.SIL**



12"

Base Model	Description	Specification
BY-PULL12V	12" Value Ladder Pull	BY-PULL12V
Option	Specification	Description
Door Material	Frameless Glass	FG
	Aluminum-Framed/Wood	AL-WD
Trim Color	3-digit finish code	See Beyond Hardware Finishes

Specification Example: **BY-PULL12V.FG.SIL**



20"

Base Model	Description	Specification
BY-PULL20	20" Ladder Pull	BY-PULL20
Option	Specification	Description
Trim Color	3-digit finish code	See Beyond Hardware Finishes

Specification Example: **BY-PULL20.SIL**

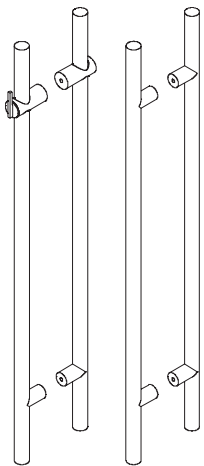

49"
Passage

49"
Locking
with SFIC

Base Model	Description	Specification
BY-PULL49	49" Ladder Pull	BY-PULL49
Option	Specification	Description
Locking Option	Passage	P
	Locking with SFIC	SFIC
Trim Color	3-digit finish code	See Beyond Hardware Finishes

Specification Example: **BY-PULL49.P.SIL**

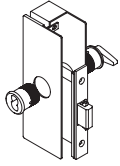

Thin Framed Sliding Door Lock

Base Model	Description	Specification
BY-SLIDINGLOCK	Sliding Door Lock	BY-SLIDINGLOCK

Option	Specification Description	Specification
Locking Option	SFIC Locking	SFIC
	SFIC Locking - Less Core	SFIC-LC
Door	Thin Aluminum Framed	TAF
Trim Color	3-digit finish code	See Beyond Hardware Finishes

Specification Example: **BY-SLIDINGLOCK.SFIC.TAF.SIL**

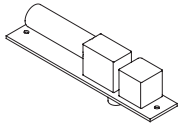

Sliding Door Electronic Lock

Base Model	Description	Specification
BY-SLIDINGELECTLOCK	Sliding Door Electronic Lock	BY-SLIDINGELECTLOCK

Option	Specification Description	Specification
Type	Single	S
	Double Active	D
Lock	Electronic Lock - Failsafe	SF
	Electronic Lock - Failsecure	SC
Trim Color	3-digit finish code	See Beyond Hardware Finishes

Specification Example: **BY-SLIDINGELECTLOCK.S.SF.SIL**

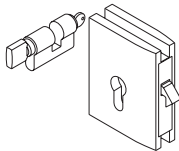

Frameless Glass

Base Model	Description	Specification
BY-SLIDINGFSLOCK	Full Strike Sliding Lock	BY-SLIDINGFSLOCK

Option	Specification Description	Specification
Door Material	Frameless Glass	FG
	Wood/Aluminum Framed Door	WA

Specification Example: **BY-SLIDINGFSLOCK.FG**

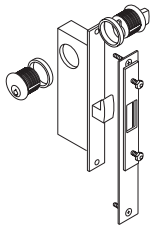

Aluminum Framed Glass/Solid

Base Model	Description	Specification
BY-SLIDINGSEALPKG	Sliding Door Seal Retrofit	BY-SLIDINGSEALPKG

Option	Specification Description	Specification
Door Material	Frameless Glass	.FG
	Bottom Seal Finish	
	Designer White	DW
	Black	E4
	Grey	EC
	Aluminum Framed	.AL
	Wood	.WD

Specification Example: **BY-SLIDINGSEALPKG.FGDW**

Door Hardware

Beyond® — Stops, Roller Latch, & Locks



Dome

Base Model	Description	Specification
BY-DOMESTOP	Dome Door Stop	BY-DOMESTOP
Option	Specification Description	Specification
Trim Color	3-digit finish code	See Beyond Hardware Finishes
<i>Specification Example: BY-DOMESTOP.SIL</i>		



Cylindrical

Base Model	Description	Specification
BY-CYLSTOP	Cylindrical Door Stop	BY-CYLSTOP
Option	Specification Description	Specification
Trim Color	3-digit finish code	See Beyond Hardware Finishes
<i>Specification Example: BY-CYLSTOP.SIL</i>		

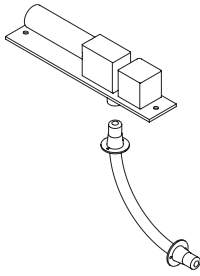

Hinged Door Electronic Lock

Base Model	Description	Specification
BY-HINGEDECLOCK	Hinged Door Electronic Lock	BY-HINGEDECLOCK
Option	Specification Description	Specification
Type	Single	S
	Double Active	DAA
	Double Active / Inactive	DAI
Lock	Electronic Lock - Failsafe	SF
	Electronic Lock - Failsecure	SC
Option	Specification Description	Specification
Trim Color	3-digit finish code	See Beyond Hardware Finishes
<i>Specification Example: BY-HINGEDECLOCK.S.SF.SIL</i>		

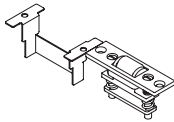

Roller Latch

Base Model	Description	Specification
BY-ROLLERLATCH	Roller Latch	BY-ROLLERLATCH
Option	Specification Description	Specification
Door	Single	S
	Double	D
Trim Color	3-digit finish code	See Beyond Hardware Finishes
<i>Specification Example: BY-ROLLERLATCH.S.SIL</i>		

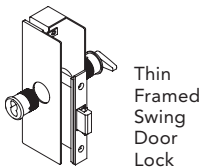

Thin Framed Swing Door Lock

Base Model	Description	Specification
BY-SWINGLOCK	Swing Door Lock	BY-SWINGLOCK
Option	Specification Description	Specification
Locking	SFIC Locking	SFIC
	SFIC Locking - Less Core	SFIC-LC
Door	Thin Aluminum Framed	TAF
Trim Color	3-digit finish code	See Beyond Hardware Finishes
<i>Specification Example: BY-SWINGLOCK.SFIC.TAF.SIL</i>		



Manual Flushbolt

Base Model	Description	Specification
BY-FLUSHBOLT	Manual Flushbolt	BY-FLUSHBOLT
<i>Specification Example: BY-FLUSHBOLT</i>		

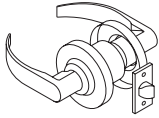

Passage

Base Model	Description	Specification
BY-LEVER	Cylindrical Lever	BY-LEVER
Option	Specification Description	Specification
Locking	Passage	P
	Locking with SFIC	SFIC
	SFIC Locking - Less Core	SFIC-LC
Door Material	Frameless Glass	FG
	Aluminum-Framed/Wood	AL-WD
Trim Color	3-digit finish code	See Beyond Hardware Finishes

Specification Example: BY-LEVER.P.FG.SIL

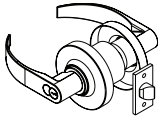

Locking with SFIC

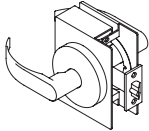

Thin Aluminum Framed Cylindrical Passage

Base Model	Description	Specification
BY-HOUSING	Cylindrical Lever Housing	BY-HOUSING
Option	Specification Description	Specification
Trim Color	3-digit finish code	See Beyond Hardware Finishes

Specification Example: BY-HOUSING.P8X

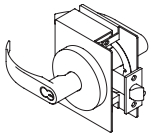

Thin Aluminum Framed Cylindrical Locking

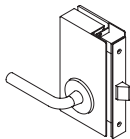

Thin Aluminum Framed Mortise Passage

Base Model	Description	Specification
BY-MLEVER	Mortise Lever	BY-MLEVER
Option	Specification Description	Specification
Locking	Passage	P
	Locking with SFIC	SFIC
	SFIC Locking - Less Core	SFIC-LC
Door	Thin Aluminum Framed	TAF
Lever	Straight Lever	SL
	Return Lever, Title 24 Compliant	RL
Trim Color	3-digit finish code	See Beyond Hardware Finishes

Specification Example: BY-MLEVER.P.TAF.SL.SIL

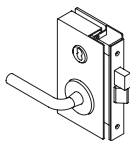

Thin Aluminum Framed Mortise Locking

Base Model	Description	Specification
BY-MHOUSING	Mortise Lever Housing	BY-MHOUSING
Option 9	Specification Description	Specification
Trim Color	3-digit finish code	See Beyond Hardware Finishes

Specification Example: BY-HOUSING.P8X

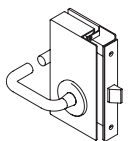

Thin Aluminum Framed Mortise Passage, Title 24

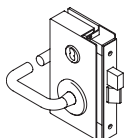

Thin Aluminum Framed Mortise Locking, Title 24

Frameless Wall Channel

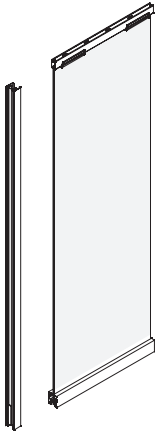

- Wall channels are used to connect frameless glass panels to drywall.
- Actual dimension of a wall channel is 2½"W.
- Planning dimension is 1½"W due to the glass nesting inside the wall channel so the wall channel only adds 1½" to the overall wall run.
- Wall channels offer +/- ¾" of adjustment.
- Specify at the same height as the adjacent frameless glass wall height.
- Wall channels for frameless glass consist of three main components. A u-channel with a foam gasket provides an acoustic seal and connects directly to the wall, utilizing the appropriate fasteners for the wall type. After the glass wall is installed, two covers interconnect with the u-channel to complete the installation. The covers incorporate a polymer extrusion to create an acoustic seal with the glass.

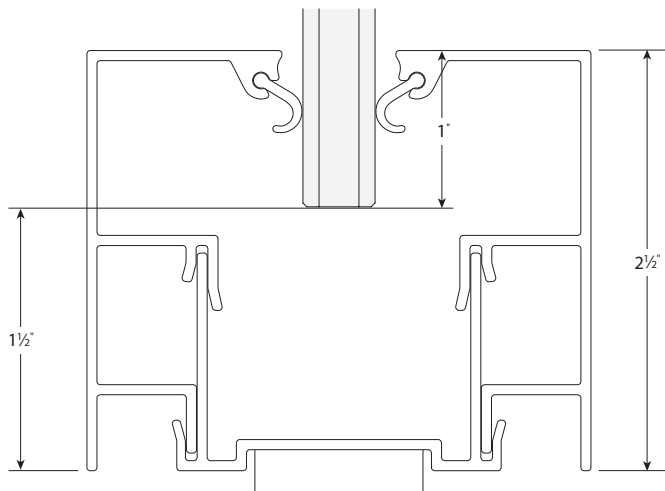

Frameless Adapters

- Adapters are used to connect frameless glass wall panels to posts, door frames, or solid wall panels.
- Actual dimension of a swing door frame-to-frameless adapter is 1 $\frac{3}{16}$ "W.
- Actual dimension of a sliding door frame/post/solid wall-to-frameless adapter is 1 $\frac{3}{16}$ "W.
- Planning dimension for both adapters is a $\frac{1}{2}$ " due to the glass nesting inside the adapter so that the adapter only adds a $\frac{1}{2}$ " to the overall wall run.
- Adapters offer +/- $\frac{1}{8}$ " of adjustment.
- Specify at the same height as the adjacent frameless glass wall height.
- Utilize the swing door frame-to-frameless adapter when connecting a frameless glass wall panel to center swing pivot or hinged door frames.
- Utilize the sliding door frame/post/solid wall-to-frameless adapter when connecting a frameless glass wall panel to sliding door frames, posts, or solid wall panels.
- Two zippers are used to connect each adapter to the post, door frame, or solid wall panel.

Frameless Adapter to Door Frame Example:

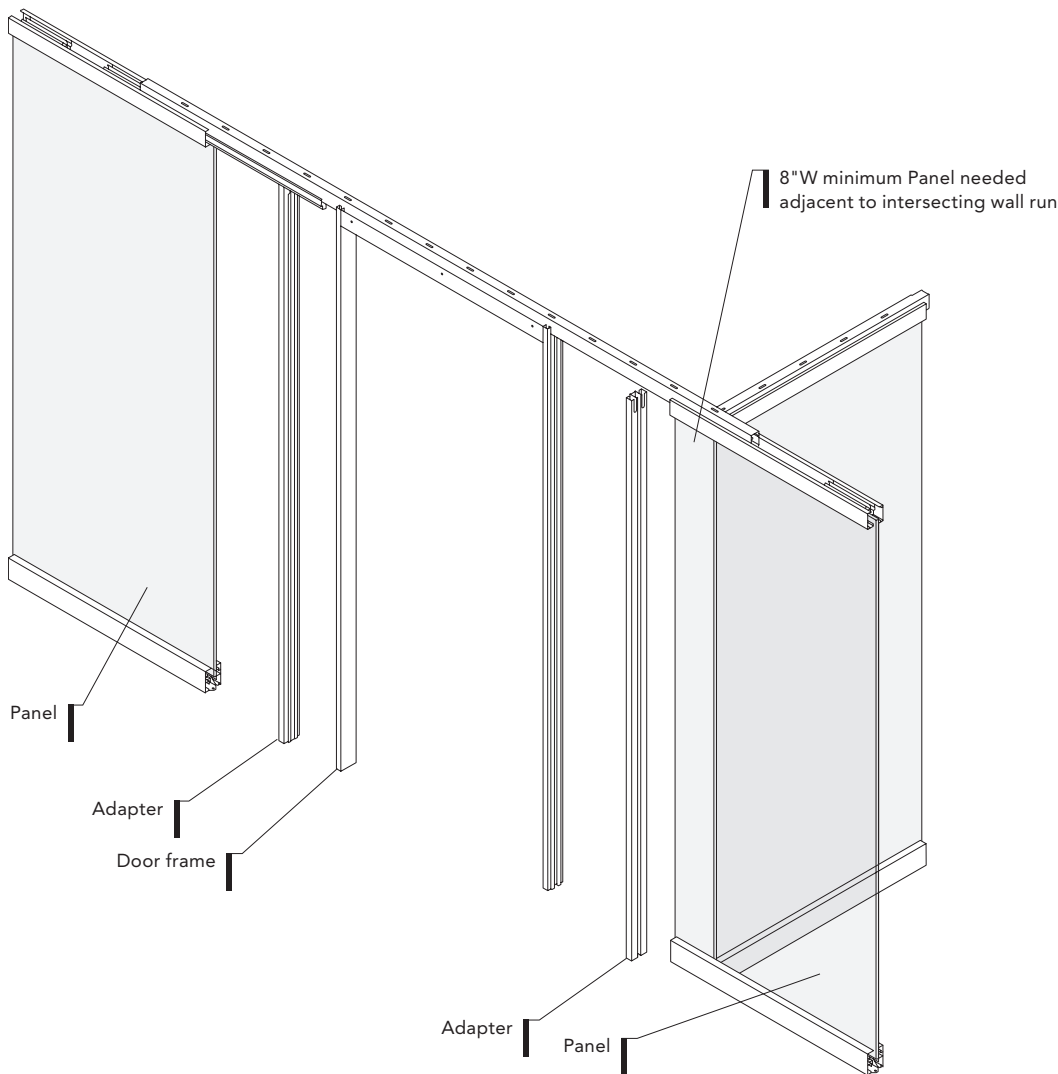

Connecting Frameless Glass to Solid and Doors

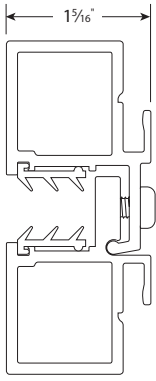

Swing Door
Frame-to-Frameless
Adapter

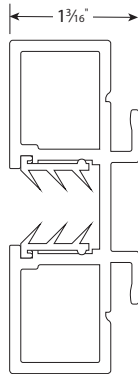

Sliding Door Frame/Post/Solid
Wall-to-Frameless Adapter

Frameless Finished End

Finished ends are utilized at the end of frameless, framed and solid wall runs that do not terminate into drywall.

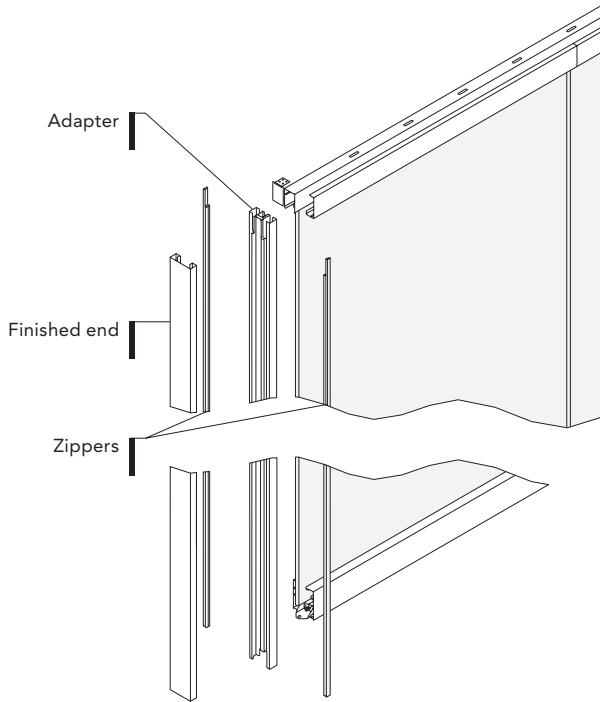

- Actual dimension of a finished end is $2\frac{15}{32}$ " W.
- Planning dimension is $1\frac{3}{4}$ " W due to the glass nesting inside the adapter.
- Finished ends offer $\pm \frac{1}{8}$ " of adjustment.
- The finished end model is comprised of a finished end and an adapter to connect to a frameless glass wall panel. The two parts are connected using two zippers.
- Specify at the same height as the adjacent frameless glass wall panel.

Wall Channel Adjacent Door

Planning Dimensions:

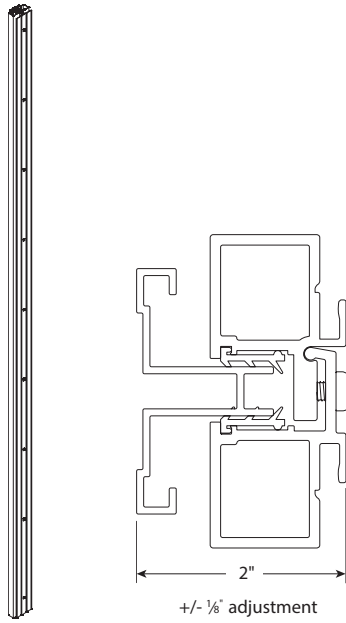

- Actual dimension of a wall channel is 2"W.
- Planning dimension is 2"W.
- Wall channels offer +/- 1/8" of adjustment.
- Specify at the same height as the adjacent door frame.
- Two zippers are used to connect the wall channel to the door frame.
- Wall channels for adjacent door applications consist of two components to connect the door frame to the wall. The first vertical extrusion is fastened to the wall using the appropriate fasteners. The second vertical extrusion clamps onto the first at the hard wall side. The opposite side is connected to the door frame using zippers. The two components fit together and allow adjustment for off plumb walls.

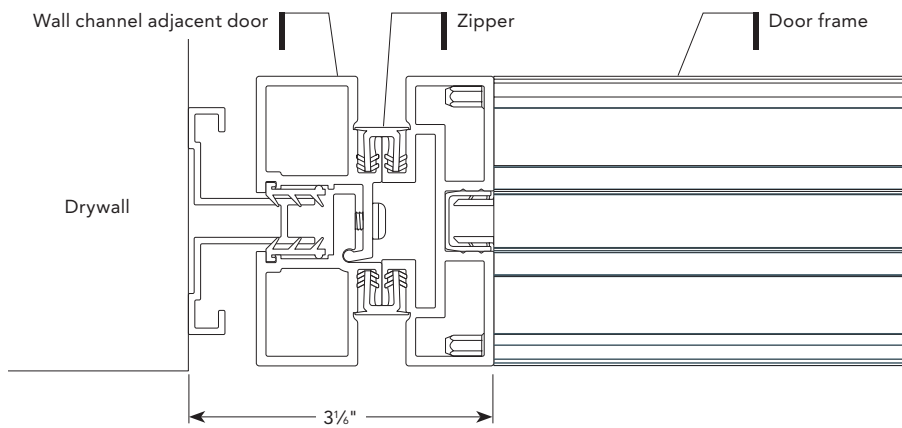

Wall channels can be used to connect framed and solid panels to drywall. Small wall channels can be used to create a more minimal aesthetic. Large wall channels can be used to allow for greater adjustment to accommodate drywall walls that are off plumb. A foam gasket, included with both wall channels, provides an acoustical seal and is pressure-fit to the wall.

Small Wall Channel

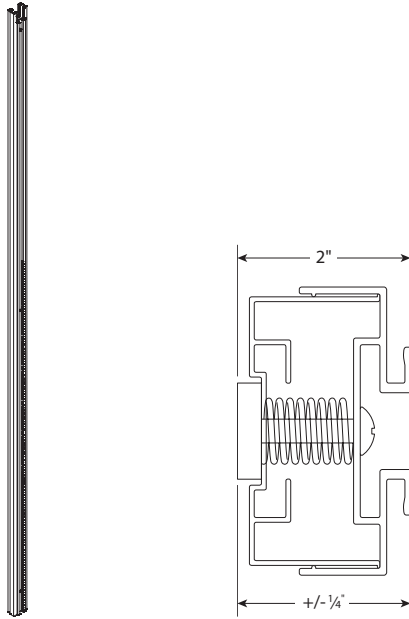

- Available from 18"-120".
- Actual and planning dimensions are both 2"W.
- Small wall channels offer +/- 1/4" of adjustment.
- Specify at the same height as the adjacent panel.
- Two zippers are used to connect the wall channel to the adjacent framed or solid panel.
 - Base and stacking posts have been consolidated into single model.
 - Use "stacking" post for nominal heights above 120".
 - "Base" post height to match nominal height of base panel.
 - "Stacking" post height to match nominal height of stacking panel.

Large Wall Channel

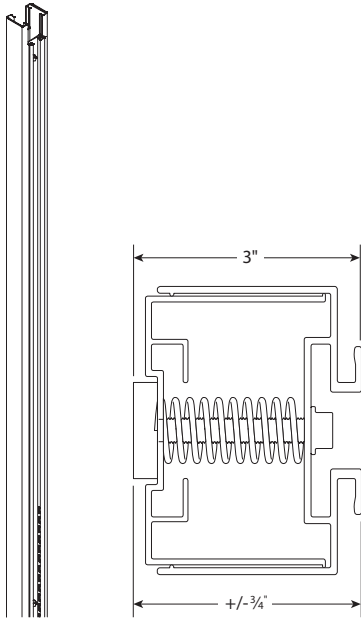

- Available from 18"-120".
- Actual and planning dimensions are both 3"W.
- Large wall channels offer +/- 3/4" of adjustment.
- Specify at the same height as the adjacent framed or solid panel.
- Two zippers are used to connect the wall channel to the adjacent panel.
 - Base and stacking posts have been consolidated into single model.
 - Use "stacking" post for nominal heights above 120".
 - "Base" post height to match nominal height of base panel.
 - "Stacking" post height to match nominal height of stacking panel.

Posts

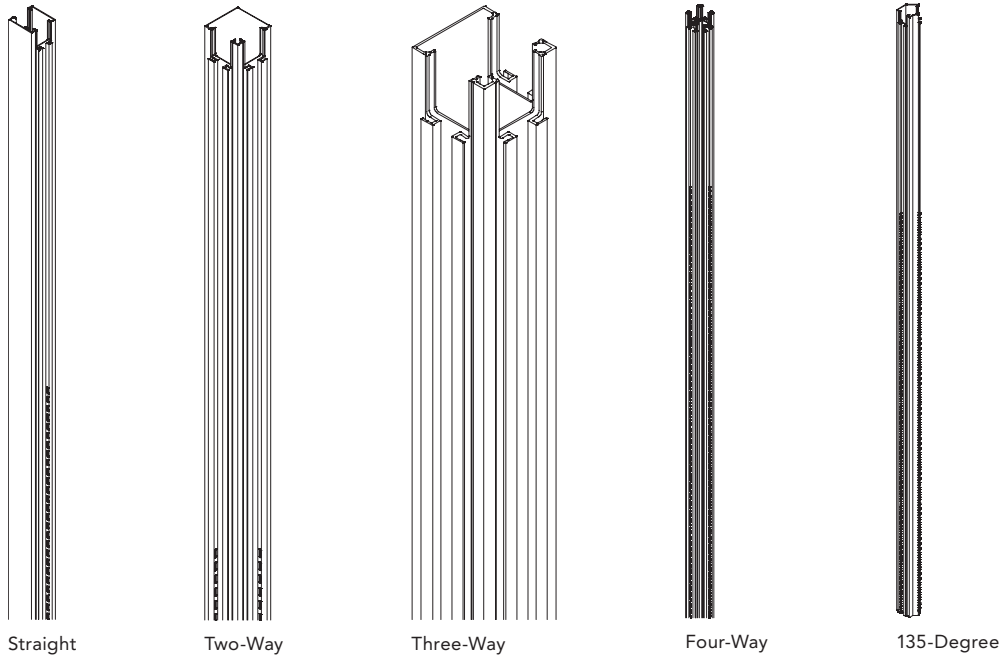

- Posts connect framed and solid panels when wall direction changes or terminates.
- Posts are available for the following connection types: straight (in-line), two-way (corner connection), three-way, four-way, and 135-degrees.
- Straight, two-way, and three-way posts can be specified with an access panel for access to electrical and data, which can then be routed through the post from the floor or ceiling. See [Beyond Electrical for more information](#).
- Optional access posts with Stride® integration allow T connections with 30"H Stride® panels. Additional heights can be accommodated as a custom solution through Tailored Products.
- Dimensions
 - Available from 18" to 120".
 - Straight actual and overall planning dimension is 3½"W or 1¾"W from centerline.
 - Two-way actual and planning dimension is 1¾" from centerline.
 - Three-way actual and overall planning dimension is 3½"W or 1¾" from centerline.
 - 135° actual and planning dimension is 1¾"W from centerline.
 - If multiple panel heights are specified, posts can be ordered to the tallest nominal panel height and cut in the field to reduce installation efforts.
- Base and stacking posts have been consolidated into single model.
 - Use Stacking post for nominal heights above 120".
 - Base post height to match nominal height of base panel.
 - Stacking post height to match nominal height of stacking panel.

Connectors

Example of a Corner Post Connection:

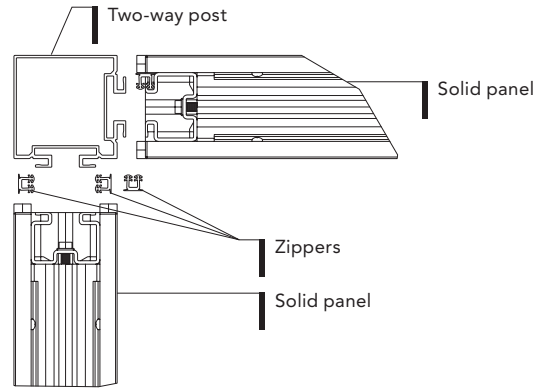
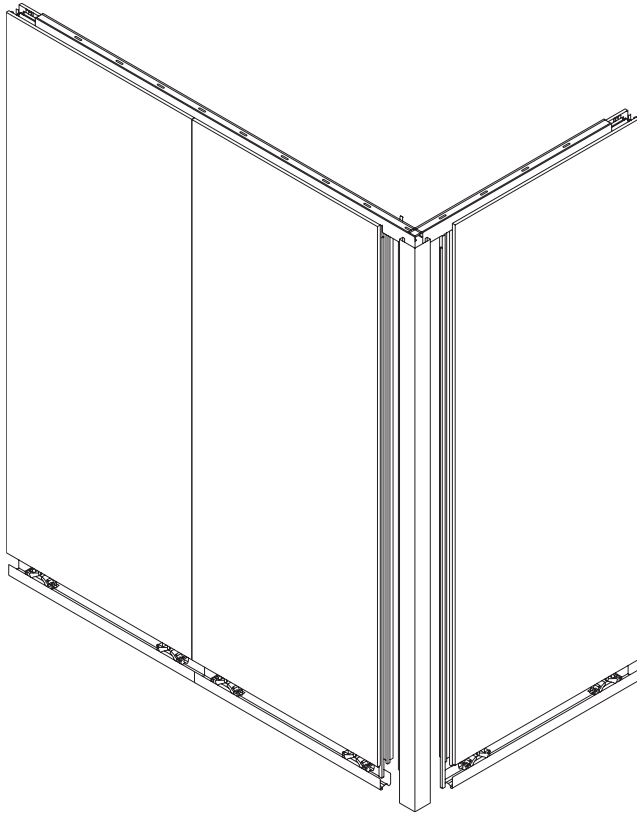

Planning Dimensions

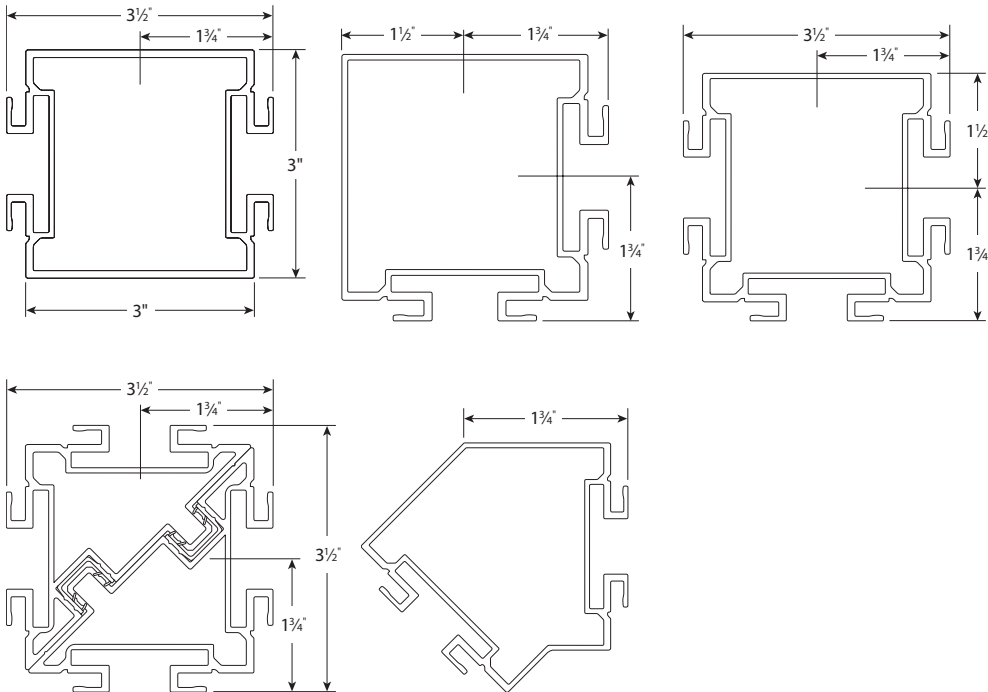

Posts with Access Trim:

Beyond posts can be specified with a removable access cover to allow for easy access to data and electrical routing. Straight, two-way, and three-way access trim posts have a removable face to allow for routing of in-feed or data from ceiling. Posts with access trim can be specified with Beyond frameless using adapters to connect to the trim.

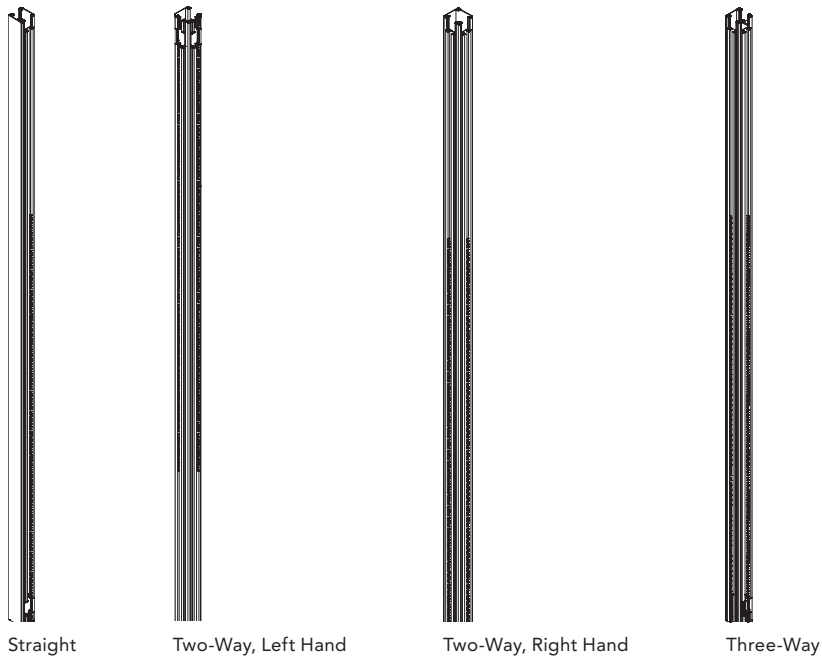

Example of Removable Access Cover:

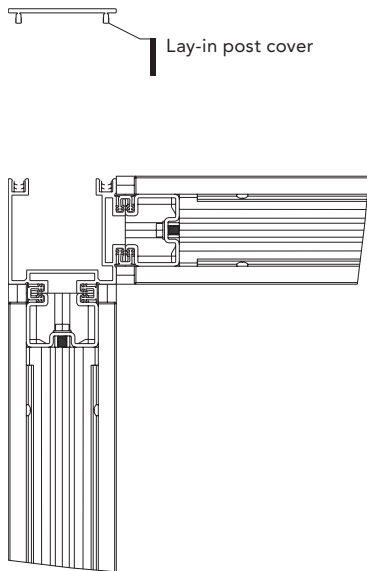

- Post with Access Trim
 - Base and stacking posts have been consolidated into single model.
 - Use “stacking” post for nominal heights above 120”.
 - “Base” post height to match nominal height of base panel.
 - “Stacking” post height to match nominal height of stacking panel.
 - Height
 - Nominal height in 1/4” increments.
 - Panels: from 18” to 120” (previously down to 86”).
 - Stacking panels: 9.5” minimum and for stacking panels with integrated mounting rail, minimum height is 10.5”.

Stacking Posts with Access Trim:

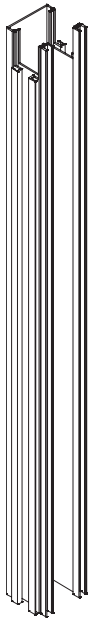

Straight

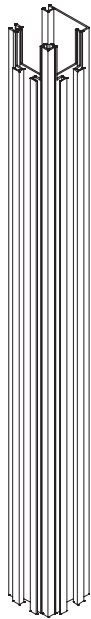

Two-Way,
Right Hand

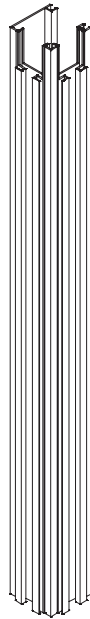

Two-Way,
Left Hand



Three-Way

Hardwired Electrical Porting for Frameless Glass Walls

Frameless glass walls can be hardwired with power utilizing the in-line electrical post. Electrical posts ship with ports in the posts and junction boxes to be installed and wired by a certified electrician.

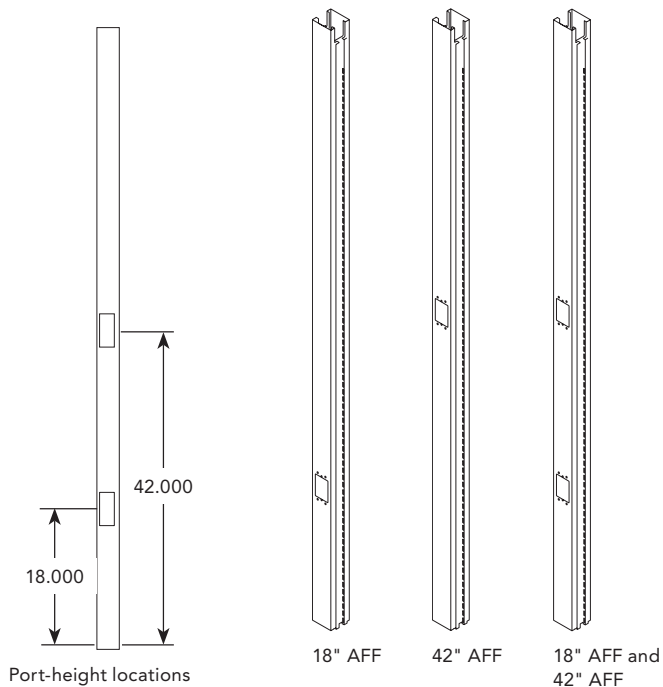

- Actual and planning dimension of an electrical ported post is 3½"W.
- Specify at nominal height for the run.

In-line electrical posts can connect directly to a door frame utilizing a zipper. They can connect to a frameless glass wall using a zipper and a frameless adapter.

Porting is available at 18" AFF, 42" AFF, or both 18" AFF and 42" AFF.

- 18" AFF indicates 18"H to the centerline of the receptacle above finished floor.
- 42" AFF indicates 42"H to the centerline of the receptacle above finished floor.
- In-line Electrical Ported Post

– Height:

- Nominal height in ¼" increments.
- Panels: from 30" to 120" (previously down to 86").
- Stacking panels: 9.5" minimum and for stacking panels with integrated mounting rail, minimum height is 10.5".

– Port Locations and Quantities – Single or double port possible. Future state, a triple port option will be added. Port locations are parametric in ¼" increments (previously only 18" and 42"). Port locations must fall within rules outlined below:

- Single port - 30" height minimum without modular electrical in the base.
- 4" port height minimum without modular electrical in the base.
- 8.25" port height minimum with modular electrical in the base.
- 4.75" minimum distance between ports center-to-center with conduit routing away from other port.
- 12.75" minimum distance between ports center-to-center with conduit routing towards the other port.
- Double port - 42" height minimum for double port.
- Recommended port placement:
 - 18" for under surface/ADA power
 - 30" for above surface power
 - 42" light switch height

– Standard and stacking posts have been combined into one base model.

Zipper-Based Connector

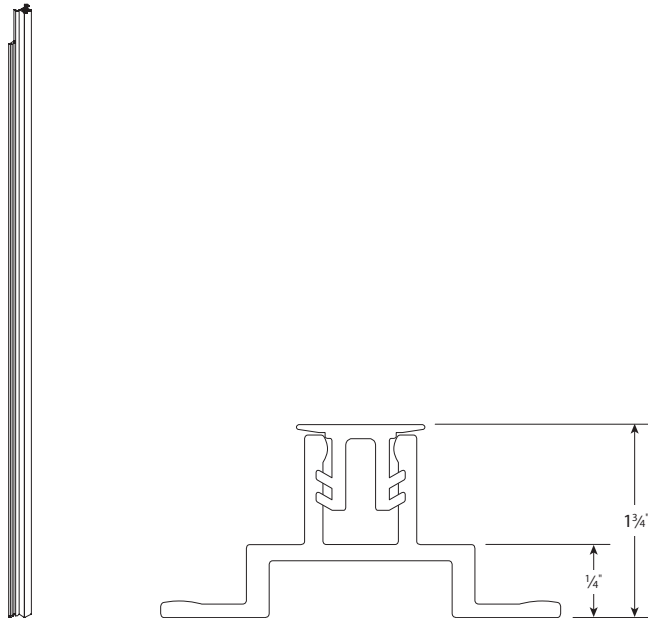

- Zipper-based connectors allow walls to connect into a zipper reveal to eliminate the need for a post with framed glass and solid walls.
 - Zipper reveals must be located directly across from each other to connect walls on both ends of the run.
 - Allows the ability to add a wall to an existing layout without interruption of adjacent panels.
 - Provides flexibility to quickly relocate and reconfigure walls with minimal disruption.
 - Must utilize “with reveal” and with base trim options on solid walls.
 - Can only be used at a zipper junction with two panels. Cannot not be used at a zipper junction with a door.
 - Planning dimension is 1 $\frac{3}{4}$ "W from centerline or $\frac{1}{4}$ " from face of perpendicular wall as the zipper-based connector adds $\frac{1}{4}$ " to the overall wall run.

Example of Zipper-Based Connection with a Solid Wall:

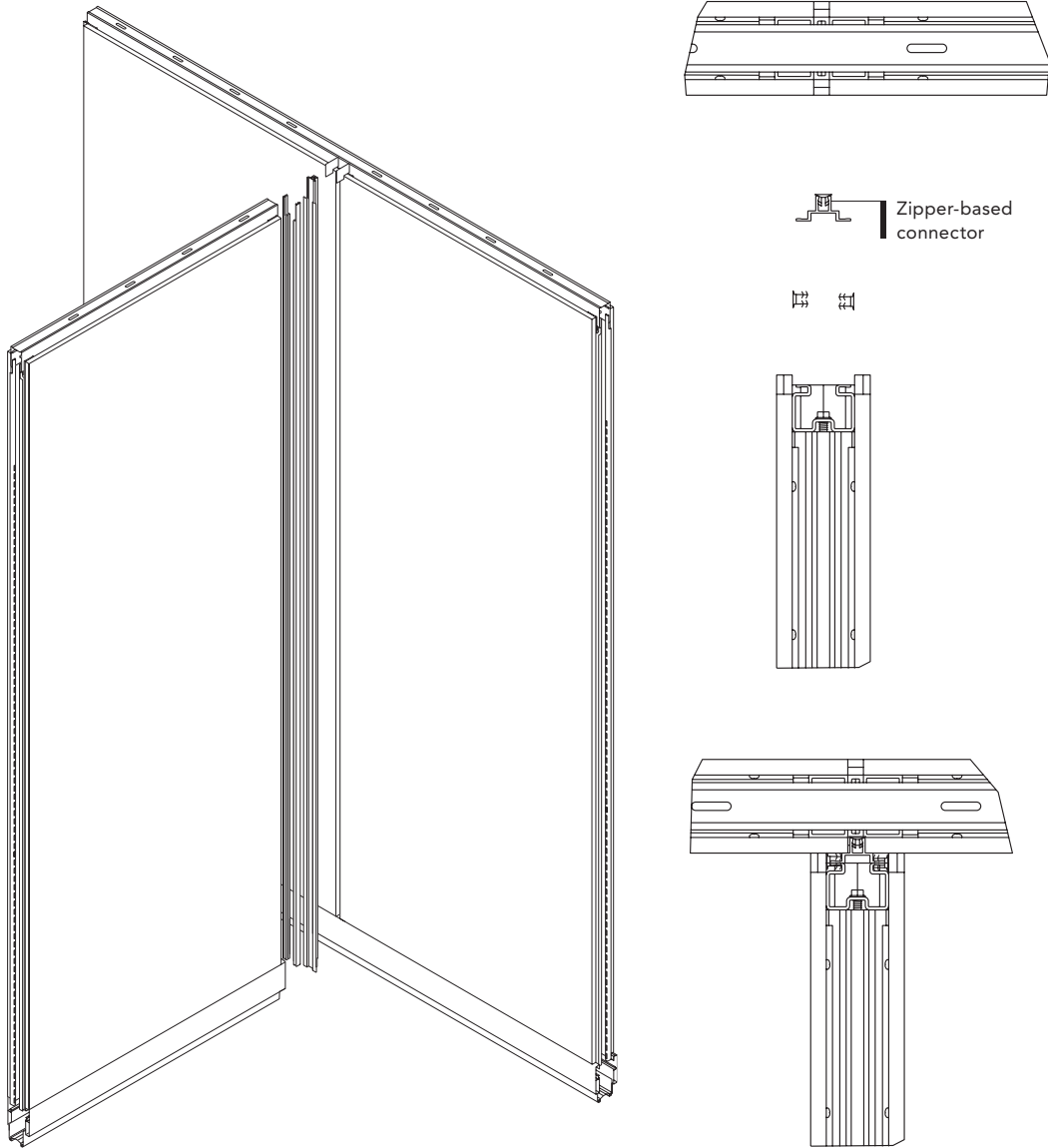

Drywall End Caps

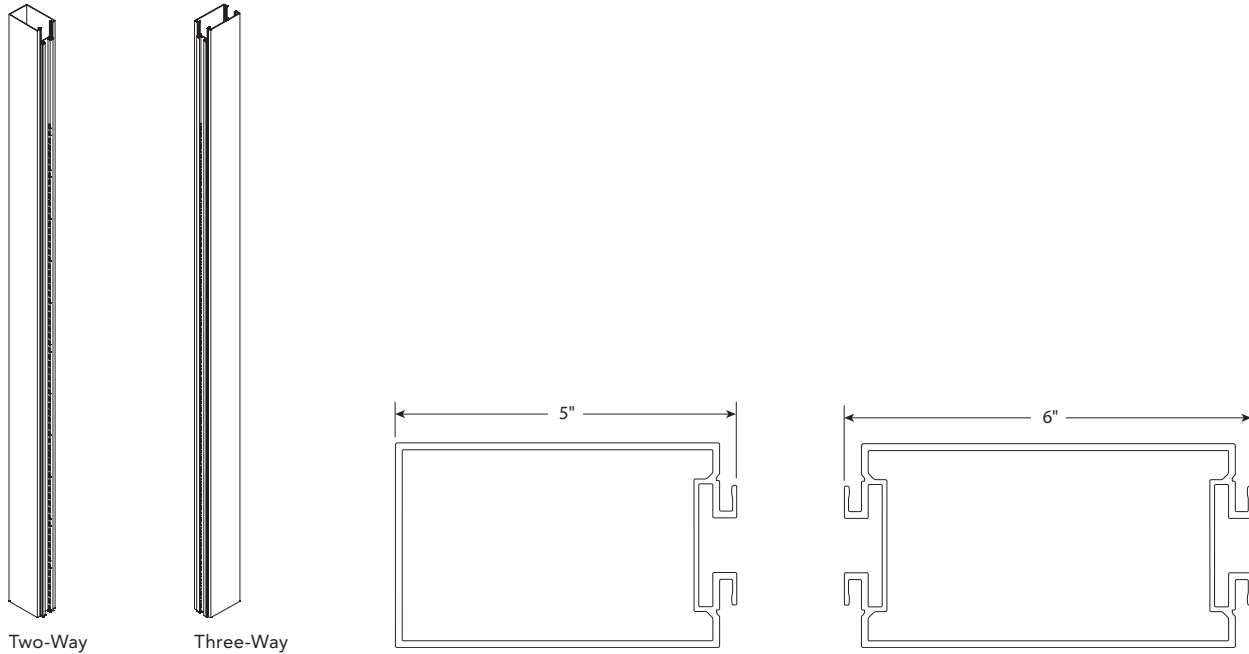

- Drywall end caps are used to create a clean, continuous look across a wall run. Two-way drywall end caps are used at the 90° connection and three-way drywall end caps are used at a three-way connection where drywall connects perpendicularly to Beyond (typically as a demising wall). The end of the Beyond wall terminates in a drywall end cap post that extends to cover the width of the drywall.
- Drywall end caps should be planned so the end of the drywall end cap post aligns with the face of the perpendicular drywall.
 - The 6" wide three-way post is engineered to accommodate drywall widths up to 5½". They should be planned so the centerline of the post aligns with the centerline of the perpendicular drywall. Contact Architectural Products Engineering prior to shop drawing completion if specifying a door adjacent to a drywall end cap with a ladder pull or non-standard lever set for the door hardware to ensure the door will open a full 90 degrees.
- Drywall end caps are non-defacing. One full height length strip of foam tape is installed to provide an acoustic seal at the demising drywall condition. Allsteel will also supply a piece of foam for the top gap between the ceiling channel and the drywall. Perpendicular drywall should be held back 3⅛" from the front face/trim of the Beyond wall. This allows for 3" wall depth + ⅛" for walls that may not be plumb – the ⅛" space will be sealed with foam tape.
- Drywall end caps connect to door frames, posts, framed glass panels, and solid panels via zippers and to frameless glass utilizing a solid-to-frameless adapter.
- Dimensions
 - Actual and planning dimensions of a two-way drywall end cap are 5" wide.
 - Actual and planning dimensions of a three-way drywall end cap are 6" wide.
 - Specify at the nominal height determined for a run.
 - If multiple panel heights are specified, end caps can be ordered to the tallest nominal panel height and cut in the field for ease of installation.

Example of Drywall End Cap Connection - Framed Glass

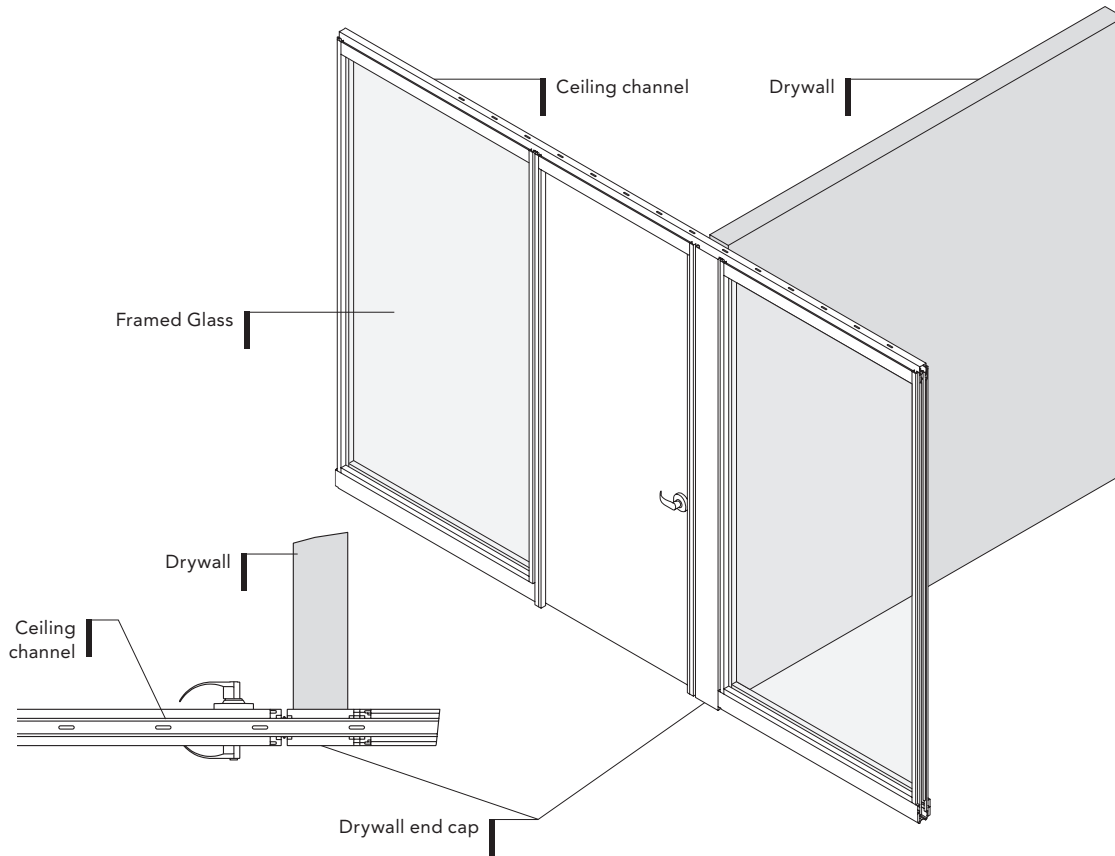

Example of Drywall End Cap Connection - Frameless Glass

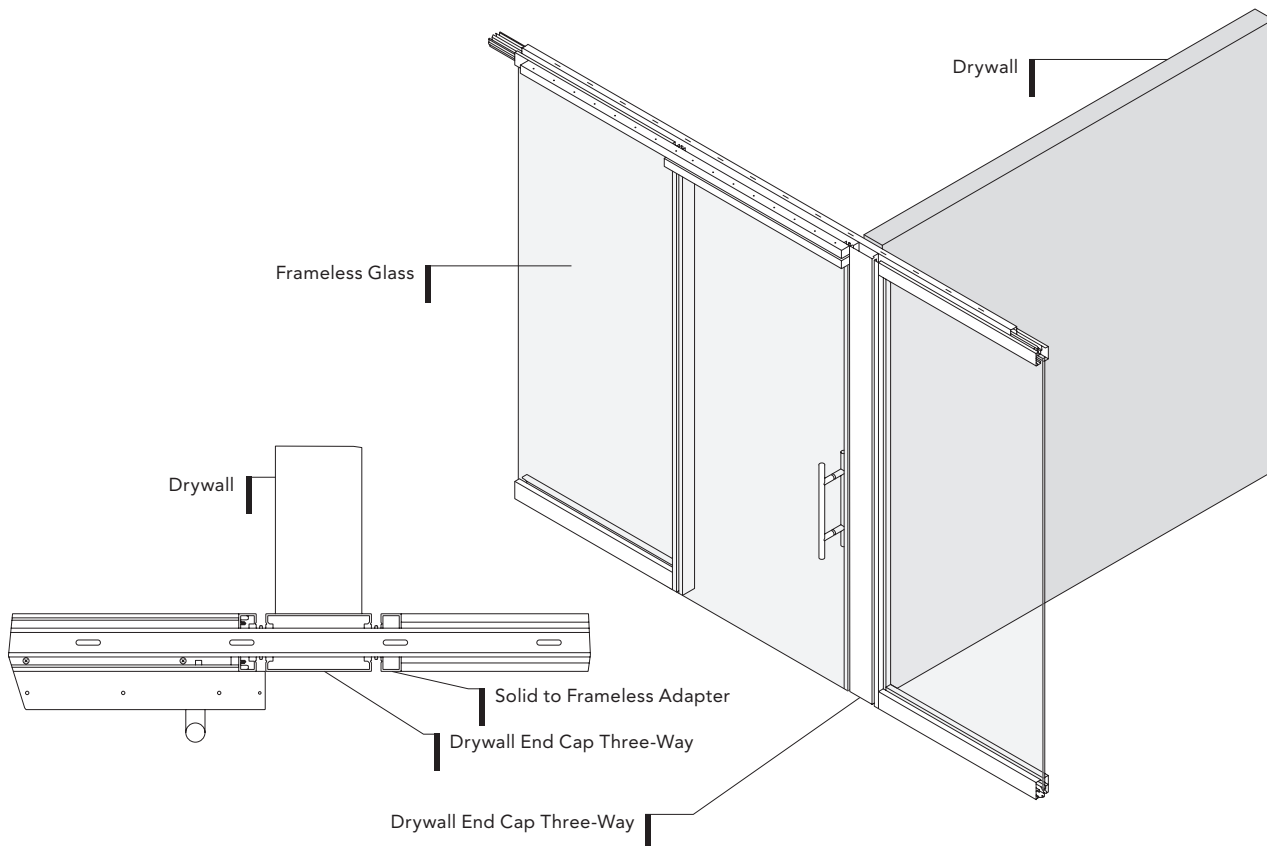

Finished Ends

Finished ends are utilized at the end, framed and solid wall runs that do not terminate into drywall.



Uniform Finished End



Uniform Finished End with Stride® Connection



Uniform Finished End - Stacking Post

- The actual dimension of a framed and solid finished end is $1\frac{1}{32}$ " in depth. Planning dimension is $1\frac{1}{4}$ ".
- The actual and planning dimension of a finished end with Stride Connection is $1\frac{1}{2}$ ".
 - Allows mounting of 30" high Stride® panel at the end of a Beyond run. Additional heights can be accommodated as an engineered-to-order (ETO) model.
 - Allows data or power in-feed to be from the ceiling into the Stride® panel.
- Specify at the nominal height determined for the run. If multiple panel heights are specified, framed and solid finished ends can be ordered to the tallest nominal panel height and cut in the field for greater ease of installation.

Planning Dimensions

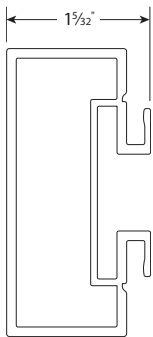

When facing obstructions in the field, a window sill u-channel can be ordered for Beyond frameless panels to accommodate the obstruction. For solid panels, a field-cuttable solid tile can be ordered.

- BY-FGSILLTRIM - Frameless Window Sill U-Channel

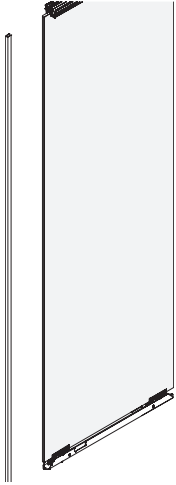

- BY-FSSILLTRIM - Solid Window Sill U-Channel

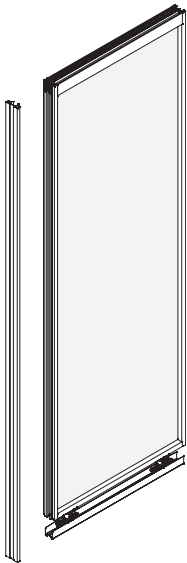

Installation Kits

- Installation kits should be specified on all Beyond projects.
 - Specify QTY (1) Beyond Installation Kit (BY-KIT) for every 150 linear feet.
 - Each kit includes additional parts and hardware useful for installation of many different applications. Examples of items included are:
 - VHB tape for use with frameless glass vertical fillers
 - Straight splice kits for ceiling channel
 - Door guides for sliding or swing doors
 - Various pieces of hardware such as washers, flat heads, bushings, etc.
 - White sponge to clean fabric tiles
- A Hard Surface Installation Kit (BY-HSKIT) should be specified (in addition to the Beyond Installation Kit) when installing on top of noncarpet flooring like wood, tile, or laminate.
 - Specify QTY (1) kit for every 50 linear feet.
 - Each kit includes a 50 foot roll of gasket tape used under the floor channel when installing.

Touch Up Paint

- Touch up paint should be specified with every painted project.
- Touch up paint can be ordered in a bottle with a brush or as a spray.
- Specify QTY (1) touch up paint kit for every 1,000 linear feet.



Base Model	Description	Specification
BY-FGWCHANNEL	Wall Channel	BY-FGWCHANNEL

Configuration ID	Specification Description
Product	Beyond
Product Type	Frameless Anodized Frameless Painted
Dimension	18"-120" In ¼" Increments
Trim Type	Wall Channel
Trim Use	Universal
Finish Color	Painted or Anodized Finishes

Option	Specification Description	Specification
Paint Color Selection	3-digit painted or anodized finish	See Beyond Frame Finishes

Specification Example: BY-FGWCHANNEL.####.P8X

BEYOND
FRAMELESS PRIVACY
TILE SYSTEM

BEYOND
VIZ

BEYOND
ELECTRICAL & DATA

BEYOND
CONNECTORS

BEYOND
DOORS

BEYOND
PANELS & TRIM

BEYOND
FINISHES & FABRICS

BEYOND
TABLE OF CONTENTS



Swing Door
Frame-to-Frameless
Adapter

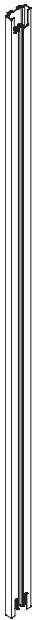

Sliding Door Frame/
Post/Solid Wall-to-
Frameless Adapter

Base Model	Description	Specification
BY-FGADAPTER	Frameless-to-Solid/Door Adapter	BY-FGADAPTER

Configuration ID	Specification Description
Product	Beyond
Dimension	18"-120" In ¼" Increments
Trim Type	Door Adapter
Trim Use	Sliding Door Swing Door
Finish Color	Painted or Anodized Finishes

Option	Specification Description	Specification
Paint Color Selection	3-digit painted or anodized finish	See Beyond Frame Finishes

Specification Example: BY-FGADAPTER.####.P8X



Frameless Finished End

Base Model	Description	Specification
BY-FGEND	Frameless Glass Finished End	BY-FGEND
Configuration ID	Specification Description	
Product	Beyond	
Dimension	18"-120" In 1/4" Increments	
Trim Type	Post	
Trim Use	Finished End	
Trim Style	Standard Low Profile	
Finish Color	Painted or Anodized Finishes	
Option	Specification Description	Specification
Paint Color Selection	3-digit painted or anodized finish	See Beyond Frame Finishes

Specification Example: **BY-FGEND.####.P8X**



Frameless Window Sill U-Channel

Base Model	Description	Specification
BY-FGSILLTRIM	Frameless Window Sill U-Channel	BY-FGSILLTRIM
Configuration ID	Specification Description	
Product	Beyond	
Product Type	Frameless Anodized Frameless Painted	
Dimension	120-0"	
Trim Type	Window Sill	
Trim Use	Frameless	
Finish Color	Painted or Anodized Finishes	
Option	Specification Description	Specification
Paint Color Selection	3-digit painted or anodized finish	See Beyond Frame Finishes

Specification Example: **BY-FGSILLTRIM.####.P8X**



Base Model	Description	Specification
BY-DWCHANNEL	Wall Channel Door Adjacent	BY-DWCHANNEL

Configuration ID	Specification Description
Product	Beyond
Product Type	Solid or Framed Solid or Framed Stacking
Dimension	18"-120" In ¼" Increments 12"-48" In ¼" Increments for Stacking
Trim Type	Wall Channel
Trim Use	Adjacent Door
Finish Color	Painted or Anodized Finishes

Option	Specification Description	Specification
Paint Color Selection	3-digit painted or anodized finish	See Beyond Frame Finishes

Specification Example: BY-DWCHANNEL.#####.P8X



Base Model	Description	Specification
BY-FSSWCHANNEL	Wall Channel Small	BY-FSSWCHANNEL
Configuration ID	Specification Description	
Product	Beyond	
Product Type	Solid or Framed Solid or Framed Stacking	
Dimension	18"-120" In ¼" Increments 12" - 48" in ¼" increments for Stacking	
Trim Type	Wall Channel	
Trim Use	Universal	
Trim Style	Small	
Finish Color	Painted or Anodized Finishes	
Option	Specification Description	Specification
Paint Color Selection	3-digit painted or anodized finish	See Beyond Frame Finishes

Specification Example: BY-FSSWCHANNEL.####.P8X



Base Model	Description	Specification
BY-FSLWCHANNEL	Wall Channel Large	BY-FSLWCHANNEL
Configuration ID	Specification Description	
Product	Beyond	
Product Type	Solid or Framed Solid or Framed Stacking	
Dimension	18"-120" In ¼" Increments 12" - 48" in ¼" increments for Stacking	
Trim Type	Wall Channel	
Trim Use	Universal	
Trim Style	Large	
Finish Color	Painted or Anodized Finishes	
Option	Specification Description	Specification
Paint Color Selection	3-digit painted or anodized finish	See Beyond Frame Finishes

Specification Example: BY-FSLWCHANNEL.####.P8X

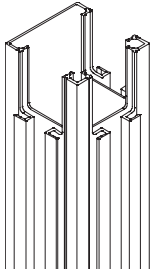

Straight

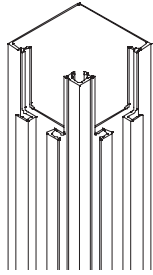

Two-Way

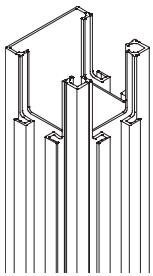

Three-Way

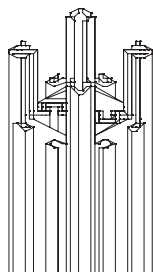

Four-Way

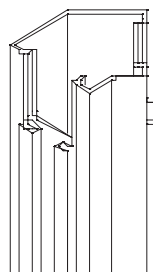

135-Degree

Base Model	Description	Specification
BY-POST	Post	BY-POST
Configuration ID	Specification Description	
Product	Beyond	
Product Type	Solid or Framed Solid or Framed Stacking	
Dimension	18"-120" In 1/4" Increments 12"-48" In 1/4" Increments for Stacking	
Trim Type	Post	
Trim Use	Straight Non Ported Two Way Three Way Four Way Angle 135	
Finish Color	Painted or Anodized Finishes	
Option	Specification Description	Specification
Paint Color Selection	3-digit painted or anodized finish	See Beyond Frame Finishes

Specification Example: BY-POST.####.P8X

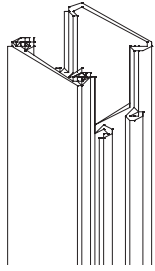

Straight

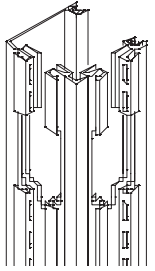

Two-Way, Left Hand

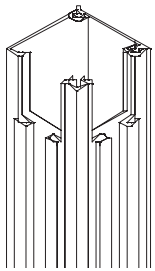

Two-Way, Right Hand

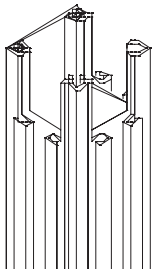

Three-Way

Base Model	Description	Specification
BY-APOST	Post with Access Trim	BY-APOST
Configuration ID	Specification Description	
Product	Beyond	
Product Type	Solid or Framed Solid or Framed Stacking	
Dimension	18"-120" In 1/4" Increments Stacking Panels: 9.5" minimum	
Trim Type	Post Access	
Trim Use	Straight Two Way Three Way	
Trim Style	Will populate If Two Way post selected Left Hand Right Hand If Stride Connection is selected For a straight or three way post: Stride For a two way post: Stride LH Stride RH	
Finish Color	Painted or Anodized Finishes	
Option	Specification Description	Specification
Paint Color Selection	3-digit painted or anodized finish	See Beyond Frame Finishes

Specification Example: BY-APOST.####.P8X



Base Model	Description	Specification
BY-POST	Post	BY-POST
Configuration ID	Specification Description	
Product	Beyond Freestanding	
Product Type	Solid or Framed	
Dimension	86"-120"H	
Trim Type	Post	
Trim Use	Two Way, Three Way without Snap-On Trim, Three Way with Snap-On Trim, or Four Way	
Trim Style	Three Way (will populate if Snap-On Trim is selected) Low Profile (Low Profile = Snap-On Trim)	
Finish Color	Painted or Anodized Finishes	

Option	Specification Description	Specification
Frame Finish	3-digit painted or anodized finish	See Beyond Frame Finishes

Specification Example: **BY-POST.####.P8X**

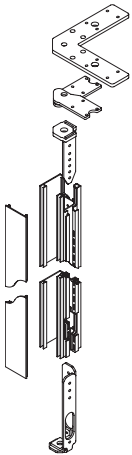

Base Model	Description	Specification
BY-APOST	Post with Access Trim	BY-APOST
Configuration ID	Specification Description	
Product	Beyond Freestanding	
Product Type	Solid or Framed	
Dimension	86"-120"H	
Trim Type	Post Access	
Trim Use	Two Way, Three Way without Snap-On Trim, Three Way with Snap-On Trim, or Four Way	
Trim Style	Will populate If Two-Way is selected Left Hand Right Hand Three Way (will populate if Snap-On Trim is selected) Low Profile (Low Profile = Snap-On Trim)	
Finish Color	Painted or Anodized Finishes	

Option	Specification Description	Specification
Frame Finish	3-digit painted or anodized finish	See Beyond Frame Finishes

Specification Example: **BY-APOST.####.P8X**



Base Model	Description	Specification
BY-APOST	Post with Access Trim (Stacking – Power Pole)	BY-APOST
Configuration ID	Specification Description	
Product	Beyond Freestanding	
Product Type	Solid or Framed Stacking	
Trim Type	Post Access	
Trim Use	Straight, Two Way, Three Way without Snap-On Trim, Three Way with Snap-On Trim	
Trim Style	Will populate If Two-Way is selected Left Hand Right Hand Will populate If Three-Way is selected Low Profile (Low Profile = Snap-On Trim)	
Finish Color	Painted or Anodized Finishes	

Option	Specification Description	Specification
Frame Finish	3-digit painted or anodized finish	See Beyond Frame Finishes

Specification Example: **BY-APOST.####.P8X**



18" AFF



42" AFF



18" AFF and
42" AFF

Base Model	Description	Specification
BY-EPOST	Electrical Ported Post	BY-EPOST

Configuration ID	Specification Description
Product	Beyond
Product Type	Solid or Framed
Dimension	48" - 120" In 1/4" Increments
Trim Type	Post
Trim Use	Straight Ported
Trim Style	Electrical
Port Type	Receptacle Post Light Switch Post Switch and Receptacle Post
Finish Color	Painted or Anodized Finishes

Option	Specification Description	Specification
Paint Color Selection	3-digit painted or anodized finish	See Beyond Frame Finishes

Specification Example: BY-EPOST.####.P8X



Zipper Based Connector

Base Model	Description	Specification
BY-ZIPPERCONN	Zipper-Based Connector	BY-ZIPPERCONN

Configuration ID	Specification Description
Product	Beyond
Dimension	120"
Trim Type	Wall Channel
Trim Use	Three Way
Finish Color	Painted or Anodized Finishes

Option	Specification Description	Specification
Paint Color Selection	3-digit painted or anodized finish	See Beyond Frame Finishes

Specification Example: **BY-ZIPPERCONN.####.P8X**

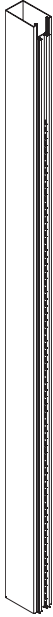

Two-Way

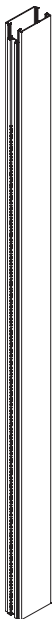

Three-Way

Base Model	Description	Specification
BY-ENDCAP	Drywall End Cap	BY-ENDCAP

Configuration ID	Specification Description
Product	Beyond
Product Type	Solid or Framed Solid or Framed Stacking
Dimension	18"-120" In ¼" Increments 12"-48" In ¼" Increments for Stacking
Trim Type	Drywall End Cap
Trim Use	Two Way Three Way
Finish Color	Painted or Anodized Finishes

Option	Specification Description	Specification
Paint Color Selection	3-digit painted or anodized finish	See Beyond Frame Finishes

Specification Example: Example: BY-ENDCAP.####.P8X

BEYOND TABLE OF CONTENTS
 BEYOND FINISHES & FABRICS
 BEYOND PANELS & TRIM
 BEYOND DOORS
 BEYOND CONNECTORS
 BEYOND ELECTRICAL & DATA
 BEYOND FRAMELESS PRIVACY TILE SYSTEM
 BEYOND VIZ



Uniform Finished End

Base Model	Description	Specification
BY-FSEND	Framed/Solid Finished End	BY-FSEND
Configuration ID	Specification Description	
Product	Beyond	
Product Type	Solid or Framed	
Dimension	Solid or Framed Stacking	
	18"-120" In ¼" Increments	
Trim Type	12"-48" In ¼" Increments for Stacking	
	Post	
Trim Use	Finished End	
Trim Style	Standard	
	Stride	
Finish Color	Painted or Anodized Finishes	
Option	Specification Description	Specification
Paint Color Selection	3-digit painted or anodized finish	See Beyond Frame Finishes

Specification Example: BY-FSEND.####.P8X

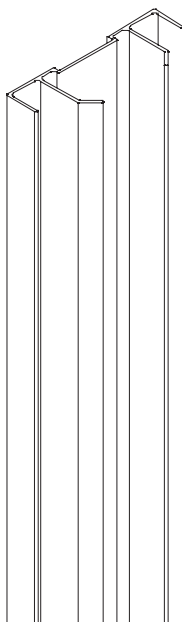

Solid Window Sill U-Channel

Base Model	Description	Specification
BY-FSSILLTRIM	Solid Window Sill U-Channel	BY-FSSILLTRIM
Configuration ID	Specification Description	
Product	Beyond	
Product Type	Solid or Framed	
Dimension	120-0"	
Trim Type	Window Sill	
Trim Use	Solid or Framed	
Finish Color	Painted or Anodized Finishes	
Option	Specification Description	Specification
Paint Color Selection	3-digit painted or anodized finish	See Beyond Frame Finishes

Specification Example: BY-FSSILLTRIM.####.P8X

Base Model	Description	Specification
BY-KIT	Installation Kit	BY-KIT

Specification Example: **BY-KIT**

Base Model	Description	Specification
BY-HSKIT	Hard Surface Installation Kit	BY-HSKIT

Specification Example: **BY-HSKIT**

Base Model	Description	Specification
BY-VHB	VHB Tape, 70' Roll	BY-VHB

Specification Example: **BY-VHB**

Base Model	Description	Specification
APTK	Touch Up Paint Brush Qty 1	APTK

Option	Specification Description	Specification
Paint Color Selection	3-digit painted finish	See Beyond Frame Finishes

Specification Example: **APTK.P8X**

Base Model	Description	Specification
ARSLCC	Spray Paint	ARSLCC

Option	Specification Description	Specification
Paint Color Selection	3-digit painted finish	See Beyond Frame Finishes

Specification Example: **ARSLCC.P8X**

Beyond frameless panels offer two options for routing power.

- Modular electrical in the base.
 - Frameless Panels: 4-wire, 2-circuit system.
- Ported for hardwired electrical.
 - Frameless Panels: Ported post with junction boxes.

Modular Electrical for Frameless Glass Walls

The 4-wire electrical system is a UL183-listed 2-circuit non-dedicated electrical system.

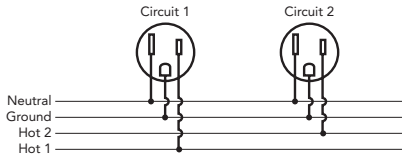

This electrical system has two hot wires, a shared neutral wire, and a shared ground wire. Each circuit is rated at 20 amps.

A maximum of 13 duplex receptacles is permitted per circuit. Each receptacle is rated at **15 amps**. Consult your electrician to ensure the planned electrical load is within permissible limits.

1. Determine location, quantity, and circuit number for duplex receptacles and power entry.
2. Electrical in-feed delivers power from building to system.
3. Power jumpers connect together duplex receptacles.

Modular power assembly for Frameless Glass walls:

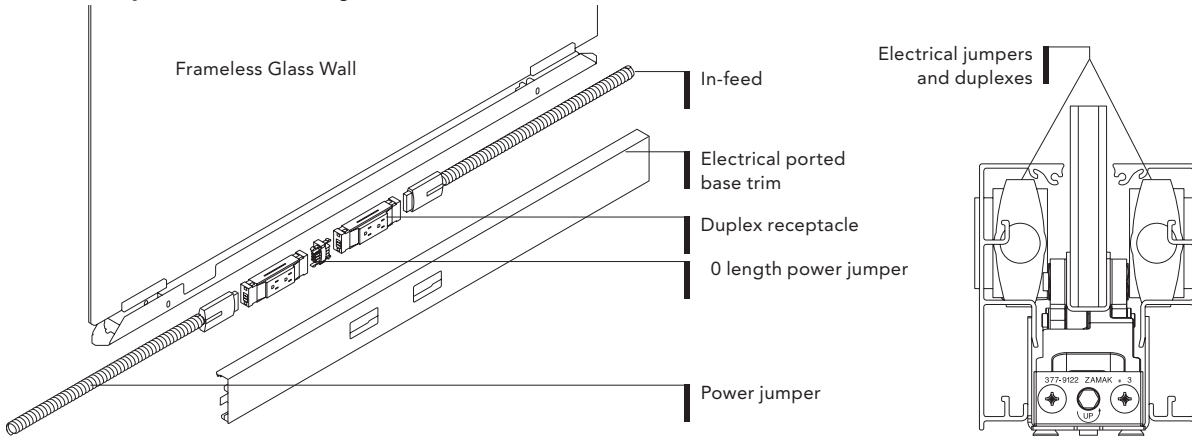

- Single power receptacles can be used on frameless glass walls that are 26" wide or wider.
- Double power receptacles can be used on frameless glass walls that are 32" wide or wider. When connecting double power receptacles, specify the 0 length power jumper (model BFG-AE4-DJ0S) to connect the receptacles together.
- Maximum of 13 circuits per infeed. Beyond frameless 4-wire power is 2 circuits, so would be 26 receptacles maximum per infeed. With Beyond framed / solid 8-wire power is 3 or 4 circuits, so would be 39 or 52 receptacles maximum per infeed.

- The receptacles and power jumpers attach to and route through the base trim. Utilize the ported base trim model to provide access to receptacles. The centerline of the receptacle must be located a minimum of 13" from the edge of the wall to prevent interference with the scissor-lift assembly.

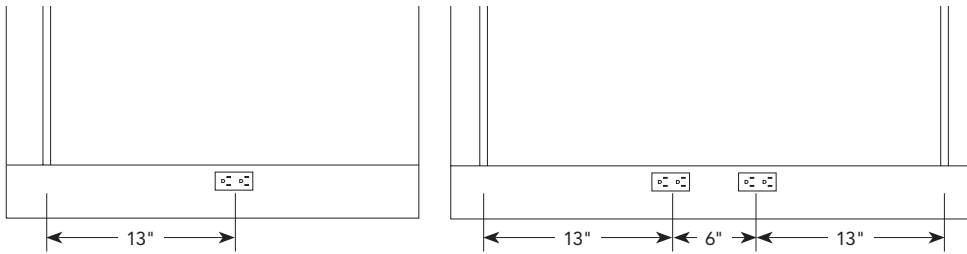

Single Receptacle

Double Receptacle

- Jumper length for connecting duplexes on separate walls is determined by the width of the receptacle centerline to receptacle centerline minus 6".

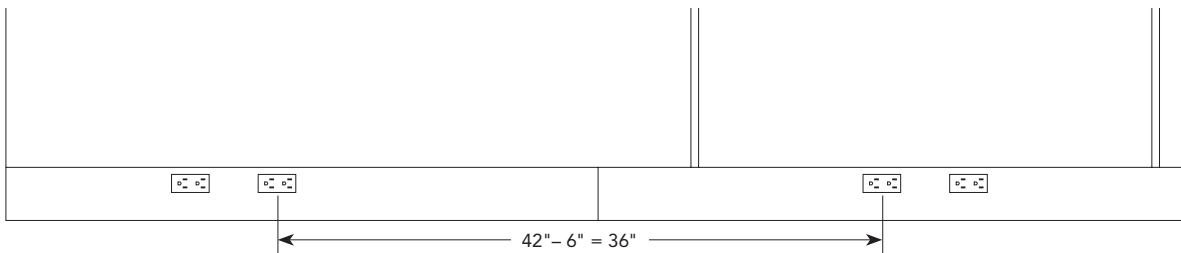

- Both sides of a frameless glass wall may be powered but requires a separate in-feed on each side of the glass.
- Modular power may not be used with low-profile base trim.
- It is the customer's responsibility to ensure that the installation of the electrical components meets all local and national building codes and all other applicable regulations.

4-Wire Electrical Components

Power Jumpers

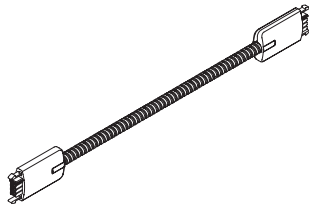

Power Jumper

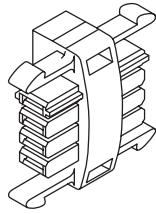

0"W Power Jumper

- UL Listed 4-wire electrical system.
- Ability to route and conceal power in frameless glass base trim.
- Length of jumper is determined by the distance from centerline to centerline of the connecting receptacles minus 6 inches.
- A 0 length jumper is used to connect receptacle to receptacle in a double receptacle application.

Duplex Receptacles

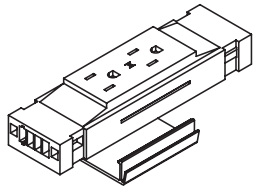

Duplex Receptacle

- 4-wire receptacles are ordered separately for circuit 1 or 2. Please [see the materials and finishes section](#) for finish options for frameless electrical components.
- 4-wire in-feed cable or jumper plugs directly into each end of a 4-wire duplex receptacle.
- 4-wire receptacle adds 6" to length of electrical run.

Electrical In-feed Cable

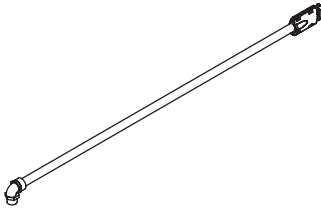

Base Electrical In-feed Cable

- Feed into the base trim through a field-ported hole in the top or the face of the base trim or from the ceiling through a wall channel, post or finished end.
- UL 183 listed to be exposed.
- Select quantity of in-feed cables depending on individual power requirements.
- Separate in-feeds are required when powering both sides of a frameless glass wall.

Frameless Base Trim with Electrical/Data Ports

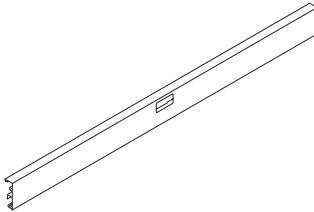

Single Receptacle

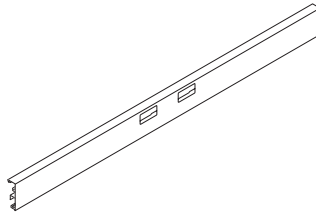

Double Receptacle

See page 171 for specification data

- Ported base trim is the same height as standard base trim.
- Ported base trim allows access to duplex receptacles or data ports.
- Available in single and double receptacle options.
- 48" in length.
- Mounting clip(s) are included to secure receptacle to the base trim.

Male-to-Male Jumper, 4-Wire

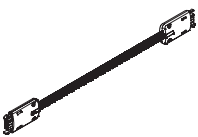

- Utilize to connect standard jumpers as a splice connection to lengthen a run.
- It is recommended that a maximum of (1) connector is used for optimal power through the cabling.

H-Connector, 4-Wire

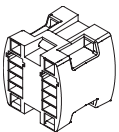

- Connects two 4-wire duplexes with a minimum distance between them.
- Allows splitting-off of another jumper to power other runs off the same in-feed.

Data for Frameless Glass Walls

The frameless glass base trim can accommodate minimal routing of data wires. An AMP data port extender is required to install the data faceplate and jack in the base trim. The following data port extenders can be ordered from AMP:

- 1933468-1 (Black)
- 1933468-2 (Light Almond)
- 1933468-4 (Nema® Gray)

Limited data wires (maximum 1 on each side) can run past the electrical in the base trim. It is recommended to keep data cabling to a minimum in frameless glass walls.

For privacy tiles “to the base,” the bottom rail overlaps the base trim. Depending on the data faceplate used, it may interfere with the snap feature.

Modular Electrical for Framed Glass and Solid Walls

Beyond framed glass and solid walls offer a choice of two modular electrical systems:

- Four-circuit, 3+1
- Four-circuit, 2+2

Both systems utilize an 8-wire electrical system, rated at 20 amps per circuit (16 amps plan-able U.S. and 15 amps Canadian). This is the same system used in Allsteel panel systems. Power can route from Beyond and connect to an Allsteel panel system.

Beyond framed glass and solid wall modular electrical components are UL 183 Listed. Electrical components are also CSA certified.

Installation and use of the electrical system, the number of receptacles used on a given circuit, and connections to the building power supply should be in compliance with all local and national electrical codes.

Caution: Electrical equipment cords and extension cords must not be routed through cable openings in the walls.

Modular power assembly for Framed Glass and Solid Walls:

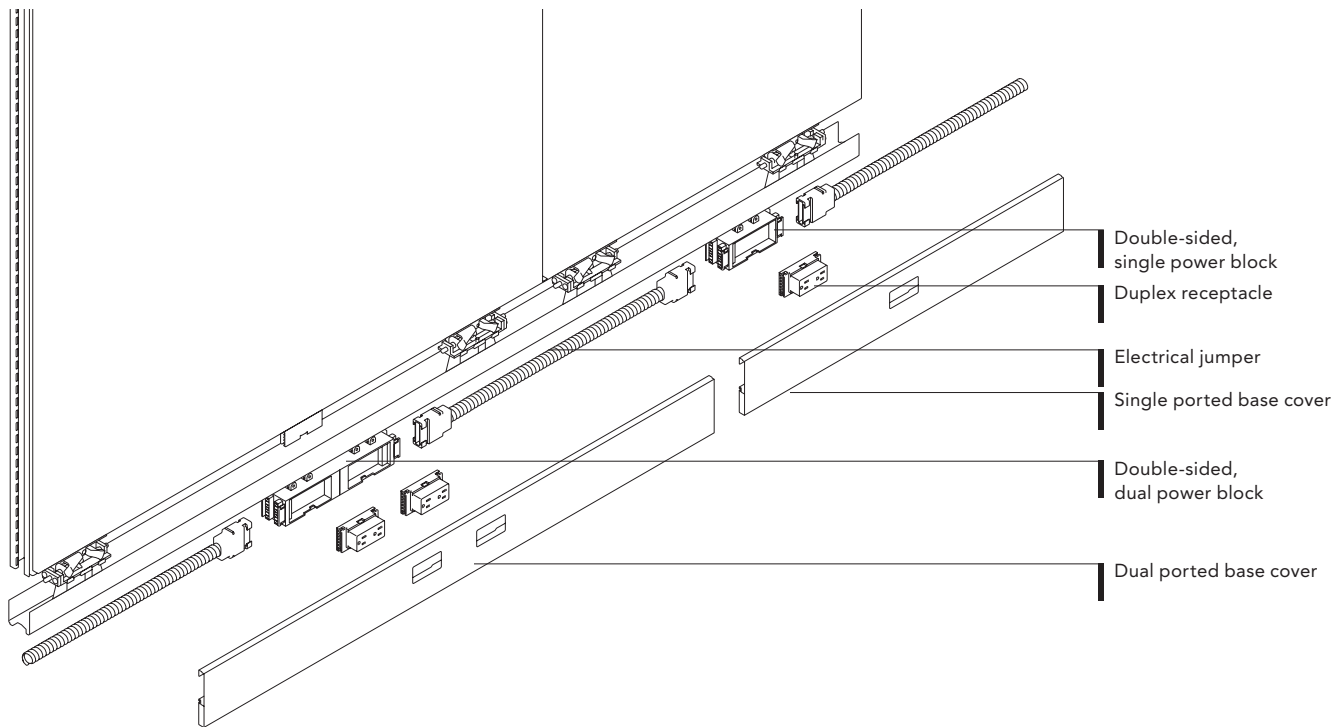

Electrical base assembly with cable capacity:

- The base pathway allows continuous voice and data lines to run through and between walls without interruption. Lay-in is provided in the base of framed glass and solid walls. Cables will need to be routed through posts.
- Cable capacity is as follows (based on 60% fill ratio of .25" diameter cables):
 - Standard base without electrical: 10 cables
 - Electrical base without electrical: 24 cables
 - Electrical base with electrical conduit on one side: 17 cables

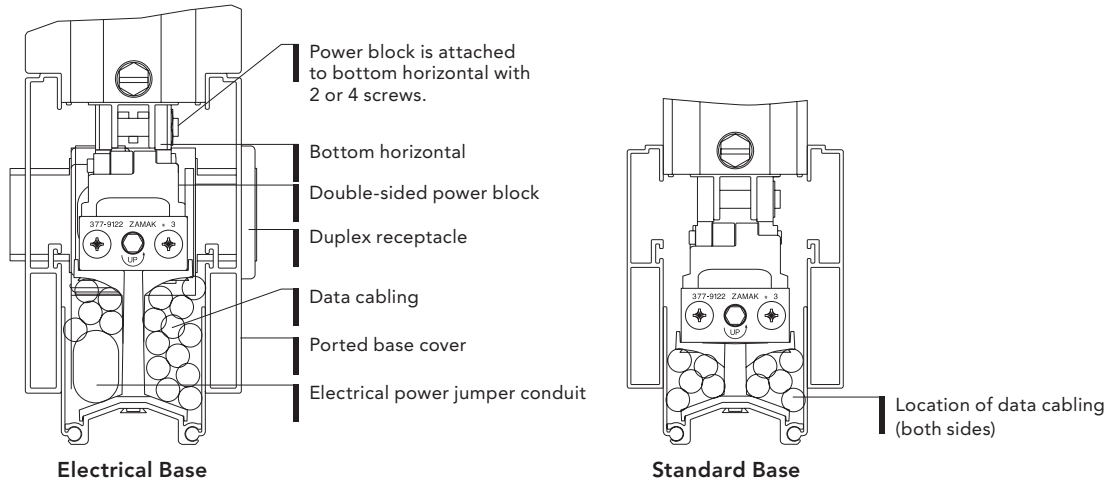

Power blocks are available with single or double receptacle locations:

- Can only be used with framed glass and solid walls specified with the Electrical Base option.
- Posts with access trim are notched at the base to allow power and data to pass through. Other posts must be field-notched.
- Power blocks allow use of duplexes on both sides of the base but do not require them on both sides. Similarly, a double power block does not require duplexes in both or either location.

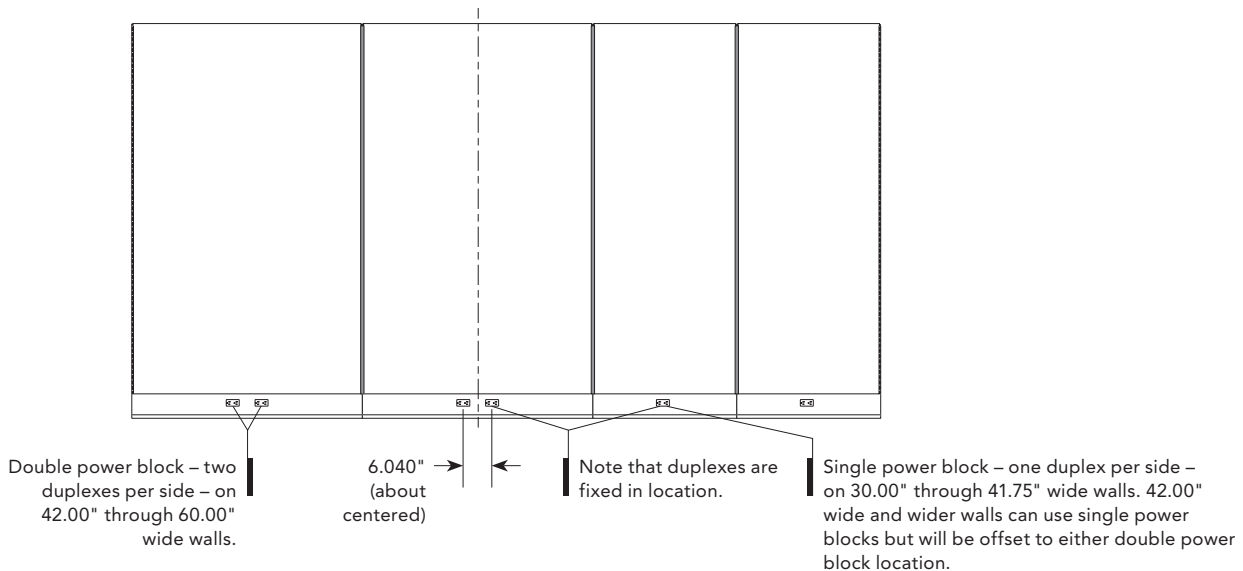

BEYOND TABLE OF CONTENTS
 BEYOND FINISHES & FABRICS
 BEYOND PANELS & TRIM
 BEYOND DOORS
 BEYOND CONNECTORS
 BEYOND ELECTRICAL & DATA
 BEYOND FRAMELESS PRIVACY TILE SYSTEM
 BEYOND VIZ

Power jumper length calculations:

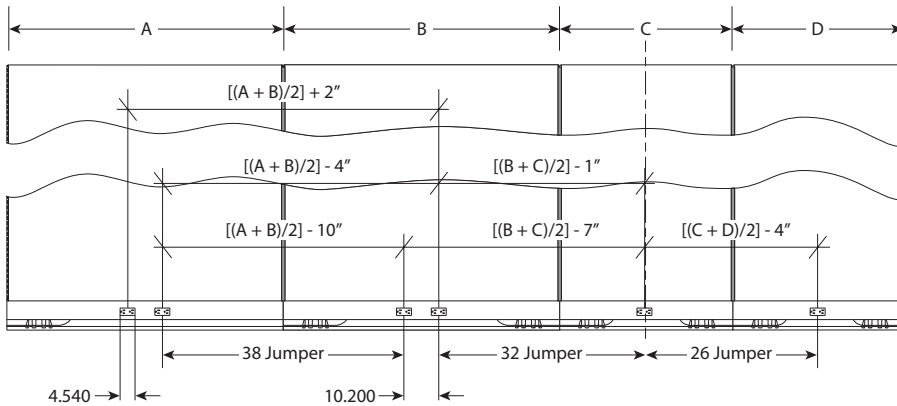

Modular power jumpers between power blocks are calculated as follows:

- From double power block to double power block (42" wide and wider walls)
Jumper length (inches) = $[(\text{Wall A width} + \text{Wall B width}) / 2] - 10$.
- From single power block to single power block (30" wide through 41.75" wide walls)
Jumper length (inches) = $[(\text{Wall C width} + \text{Wall D width}) / 2] - 4$.
- From double power block to single power block (30" wide through 41.75" wide wall adjacent to a 42" wide and wider wall)
Jumper length (inches) = $[(\text{Wall B width} + \text{Wall C width}) / 2] - 7$.
- Note that if there is an additional wall between the power blocks, add that width to the width of the jumper required.
- When calculating power in-feeds, allow 48" of overall length to remain in the ceiling for attachment to building electrical.
- Additionally, a jumper can run from a single power block to a single power block on a wall wider than 42" (typically for a double power block). These can be in a similar location; far locations or closer locations and will have different jumper lengths for each option.
- If a jumper crosses a post, add 3" to the length of the jumper.

Electrical and Data Ported Base Trim Details:

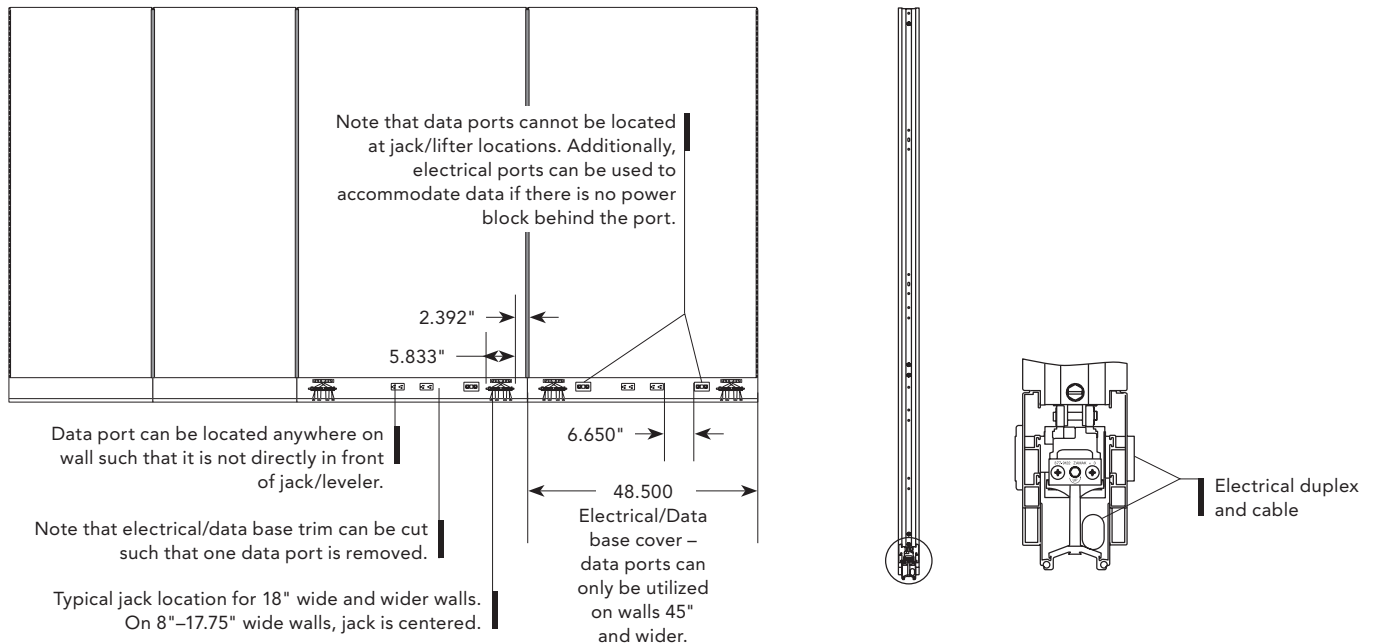

When specifying modular electrical:

1. Determine which electrical system you will use after consulting your electrician and computer support personnel:
 - Four-circuit system (4 Hot/2 Neutral/2 Ground)
 - 3+1 option
 - 2+2 option
2. Determine location, quantity, and circuit of duplexes.
3. Determine the appropriate choice and use of Isolated, Isolated/Dedicated, and Separate Neutrals circuits.
4. Specify appropriate Power Harnesses.
5. Determine the location, quantity, and type of Power In-feeds needed.

ASHRAE® 90.1 is an Energy Standard that requires some portion of receptacles in an office or workstation be controlled by an automatic control device. This device will switch off power to the controlled circuit(s) when the space is not occupied. Receptacles that are in a switched circuit must be marked per the standard. It is the customer's responsibility to ensure that the specification and installation of the electrical components meets all local and national building codes and all other applicable regulations.

- Utilize modular electrical 2+2 for ASHRAE® 90.1.
 - Live circuits: 1 and 2
 - Switched circuits: 3 (BFS-877517) and 4 (BFS-877509)
 - Control device in the building wiring
- Maximum of 13 circuits per infeed. Beyond framed / solid 8-wire power is 3 or 4 circuits, so would be 39 or 52 receptacles maximum per infeed.

Flexconnect™ Electrical System Options

The four-circuit, eight-wire electrical system is widely specified and trusted by hundreds of thousands of end users. This proven system delivers four circuits for every power in-feed in either a 3+1 or 2+2 configuration. The isolated/dedicated circuits are ideal for sensitive computing equipment, while the common circuits are suitable for faxes, copiers, task lights, and other peripherals. Both the 3+1 and 2+2 systems use the same pre-wired components, making it easy to adjust as electrical needs change.

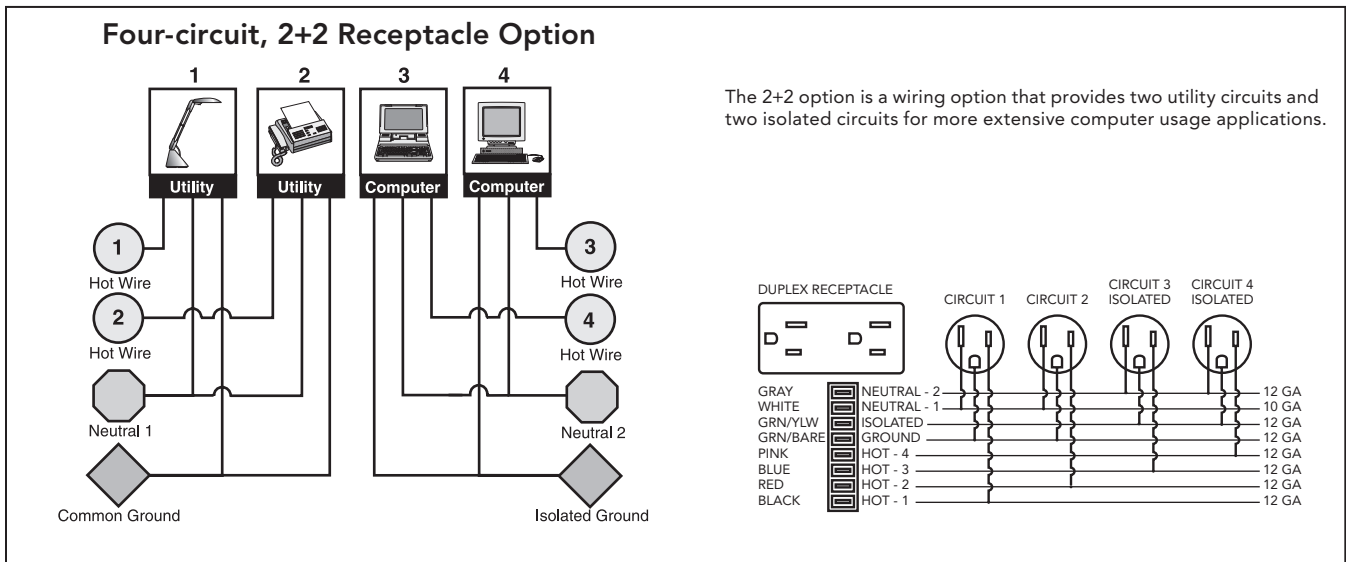
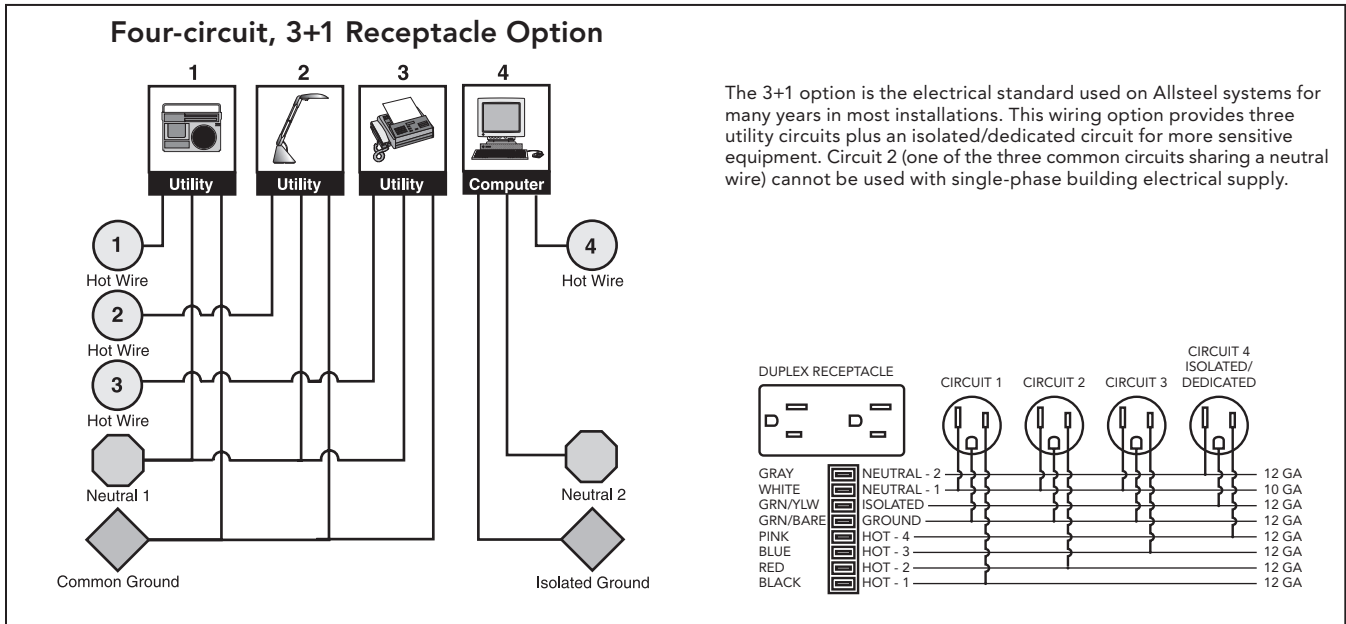

BEYOND TABLE OF CONTENTS
BEYOND FINISHES & FABRICS
BEYOND PANELS & TRIM
BEYOND DOORS
BEYOND CONNECTORS
BEYOND ELECTRICAL & DATA
BEYOND FRAMELESS PRIVACY TILE SYSTEM
BEYOND VIZ

Beyond Receptacle Usage					
Two 8-wire, 20-amp (15-amp Canadian) electrical systems are offered					
Electrical System	Circuitry	Receptacle Capacity			
Four-circuit 4 Hot/2 Neutral/2 Ground	3+1	Common Circuit-1 BFS-877501	Common Circuit-2 BFS-877502	Common Circuit-3 BFS-877503	Iso/Dedicated Circuit-4 BFS-877504
	2+2	Common Circuit-1 BFS-877501	Common Circuit-2 BFS-877502	Isolated Circuit-3 BFS-877506	Isolated Circuit-4 BFS-877504

Duplex Receptacles:



15-amp Receptacle

(1) Circuit 2 (one of the three common circuits sharing a neutral wire) cannot be used with a single-phase building electrical supply.

Office Equipment Typical Load Values

Item	*Amps
Desktop Computer	4
Laptop Computer	1
Laptop/Monitor/Docking Station	4
Paper Shredder	1.22
Radio	0.05
Scanner	3
Space Heater (1500 watts)	12
Task Light (equiv. 60-watt bulb)	
Fluorescent	0.12
LED	0.08
USB Charger	0.17
LCD Television (42")	1
LCD Monitor (21")	0.5
Bluetooth Speaker	0.1
Desktop Printer	
Inkjet	0.15
Laser	4 to 10
Multimedia Projector	1.7
Sit-to-Stand Height-Adjustable Desk	Idle 0.01 / Max 4
Office Kitchen	
Coffee Maker	10
Microwave	10
Toaster	12.5
Compact Refrigerator	1.5

*Chart is recommended for planning purposes. Check device specifications for exact amperage. Consult with your electrician regarding the applicable configurations.

Examples of Component Usage based on the Office Equipment Typical Load Values Chart

Power Option 3+1
Dedicated Circuit 4: 4 desktop computers with 2 monitors each; or 10 laptop computers
Utility Circuits 1, 2, 3: Height-adjustable tables and ancillary items

Power Option 2+2
Dedicated Circuit 3: 4 desktop computers with 2 monitors each; or 10 laptop computers
Dedicated Circuit 4: 4 desktop computers with 2 monitors each; or 10 laptop computers
Utility Circuits 1, 2: Height-adjustable tables and ancillary items

Power Option 3 (Circuit-separate neutrals)
Dedicated Circuit 3: 4 desktop computers with 2 monitors each; or 10 laptop computers
Utility Circuits 1, 2: Height-adjustable tables and ancillary items

Circuit Usage

Strategy 1

Circuits to Equipment

Assign specific uses for each of the circuits. For example:

- Circuit 1 – Calculators, Fans, etc.
- Circuit 2 – Task Lights
- Circuit 3 – Monitors
- Circuit 4 – CPUs

Strategy 2

Circuits to Offices

Assign specific offices to each of the three available circuits. Use circuit 4 for power-sensitive electronic equipment.

Modular Electrical Components

Power Blocks

- Specify a single centered power block for walls 30" wide to 41¾" wide.
- Specify an offset single or centered double power block for walls 42" wide to 60" wide.
- Power blocks are double sided and provide power access to both sides of the wall. Power may be accessed on a single side only if not needed on both sides of the wall.
- Connections at both ends of the power block allow power distribution in either direction.
- Power blocks attach with screws to pre-milled holes in the wall frame.

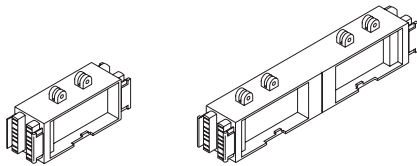

Single Power Block

Double Power Block

Power Jumper Cables

- Electrical jumper cables connect power from power block to power block.
- Post width (3") must be added to the power jumper cable length when crossing a post condition.

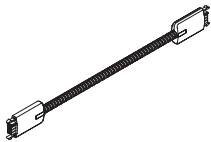

Pass-Thru without Power Block

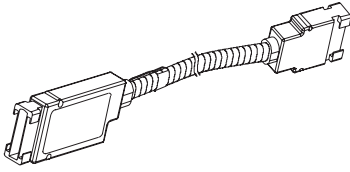

Electrical In-feeds

- Power in-feed cables deliver power from the building to the wall's electrical system.
- In-feed cables are housed in conduit to separate the electrical system from communication and data lines.
- Select the quantity of base or ceiling in-feed cables depending on individual power requirements.
 - Sealtight Base Pathway Power In-feed
 - Attaches to any receptacle opening in the base pathway.
 - A heavy rubber sheathing shields conduit, allowing in-feed to be exposed.

Base Power In-Feed

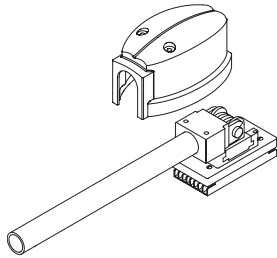

Ceiling Power In-Feed

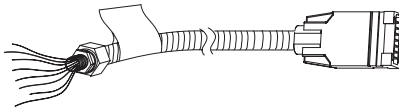

- Connects to a powerblock and travels in the base pathway and up through a post or wall channel to above the ceiling. An electrician will then connect to the building power supply.
- Most codes permit flex conduit to be exposed after installation. Verify code requirements before ordering for an exposed application.

Duplex Receptacles

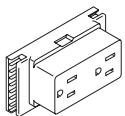

- Duplex receptacles snap into power blocks.
- Available in multiple colors. [See the Materials and Finishes section for available color options.](#)
- Each receptacle is labeled to indicate which circuit it will be connected to: 1, 2, 3, or 4.
- Specify duplexes to support either 3+1 and 2+2 electrical systems.
- Duplexes for switched receptacles are marked as required by ASHRAE® 90 and must be specified as switched receptacles.

Base Trim with Electrical/Data Ports

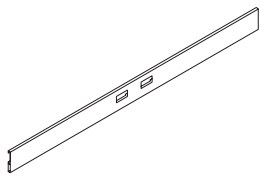

Electrical Ported Base Trim

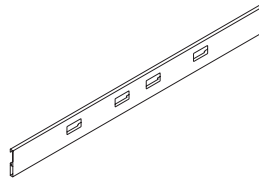

Electrical and Data Ported Base Trim

See page 116 for specification.

- Utilize the electrical base trim for projects with modular electrical. Base trim connects to the base channel and is specified on both sides of the panel. The electrical base trim is 1" taller than the standard, non-electrical trim.
- 4⁵/₈" H for trim itself.
- 5³/₁₆" H from finished floor to top of trim with nominal reveal of 3/4".
- Non-ported electrical base trim is available in 120" lengths only.
- Framed and solid pre-ported base trim at 60¹/₂"W is available for single or double receptacles.
- Double port & data is available for panels greater than 45"W. It is not recommended on panels greater than 48"W in width.
- Base trim that is 48¹/₂"W with QTY (2) additional data ports allows data to be placed to the right or left of the duplex receptacles. This is available for double receptacles only. Trim can be cut in the field so that one data port is removed if it's not used.
- Due to wall depth, back-to-back data modules should not be used. If required, it is recommended that extended data faceplates be used. Width is 48".
- All electrical and data ported trim for framed and solid panels comes with enhanced gasketing.

Single Port:

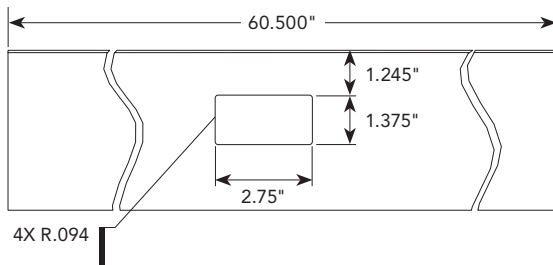

Double Port:

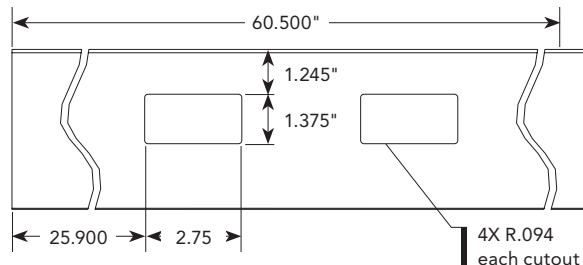

Double Port + Data:

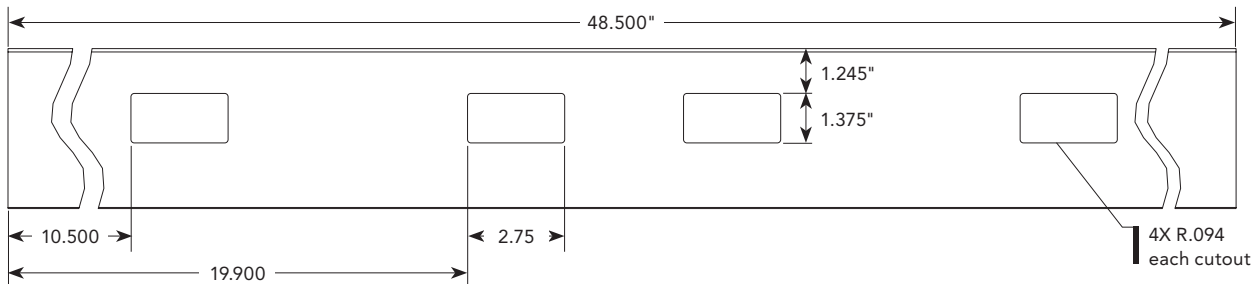

Base Channel Junction Box

For Chicago Code compliance, utilize the base channel junction box for electrical in the base channel with the hardwire box and box trim. Customer must furnish conduit, wiring and receptacles.

The Hardwired box consists of a UL Listed junction box that mounts in electrical base height framed glass or solid walls base area. These boxes are field-installed and wired. They are shipped as single-sided configuration and can convert to dual-sided by removing the plate on the rear of the box. Requires use of specific base trim made for this box. It is configured for dual boxes on 48" wide panels with data cutouts. It can be cut to be used for other configurations.

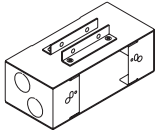

Hardwired box for base

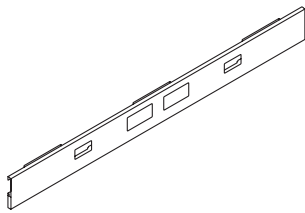

Utilize 48"W electrical trim ported for double receptacles only with additional data ports when utilizing a hardwired box. This allows data to be placed to the right or the left of the duplex receptacles. The data port not used is field cut off of the trim prior to installing on wall. See page [286](#) for specification detail.

Wire Managers

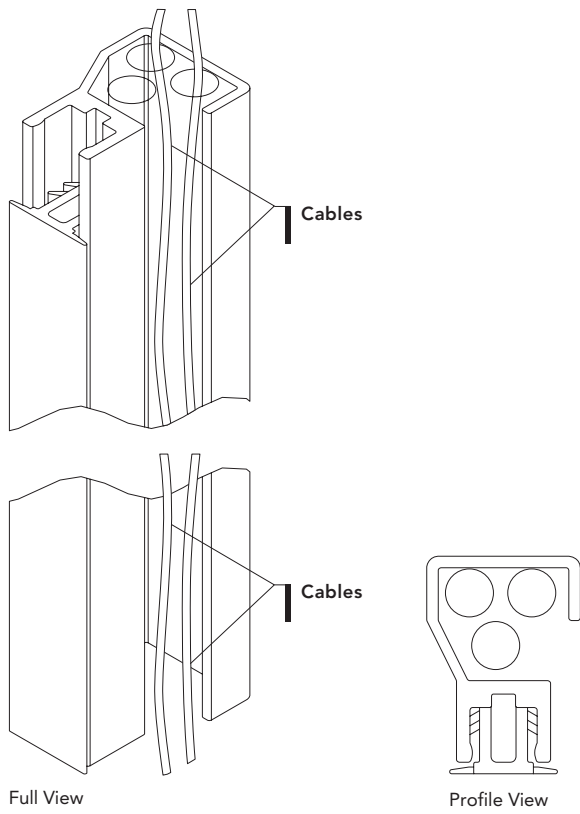

- Wire managers are 78" in length and can be field-cut to the size needed to manage cabling.
- Cables are fed into the reveal on the side and can manage up to QTY (3) ¼" diameter cables.
- Can be used with both framed glass and solid wall.
- Wire managers are press-fit into a zipper reveal.
 - Requires "with reveal" option for solid walls.

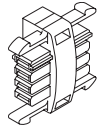
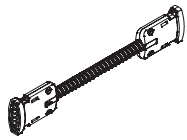

0"W

Base Model	Description	Specification
BY-FG4JUMPER	Jumper, 4-wire	BY-FG4JUMPER

Option	Specification Description	Specification
Length	0"W	2C-0W
	6"W	2C-6W
	12"W	2C-12W
	18"W	2C-18W
	24"W	2C-24W
	30"W	2C-30W
	36"W	2C-36W
	42"W	2C-42W
	48"W	2C-48W
	54"W	2C-54W
	60"W	2C-60W
	66"W	2C-66W
	72"W	2C-72W
	78"W	2C-78W
	84"W	2C-84W
	90"W	2C-90W
	96"W	2C-96W
	102"W	2C-102W
108"W	2C-108W	
114"W	2C-114W	
120"W	2C-120W	
126"W	2C-126W	
132"W	2C-132W	
138"W	2C-138W	
144"W	2C-144W	

Specification Example: **BY-FG4JUMPER.2C-144W**

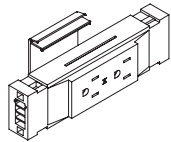

Duplex Receptacle

Base Model	Description	Specification
BY-FG4DUPLEX	Duplex, 4-Wire	BY-FG4DUPLEX

Option	Specification Description	Specification
Circuit Type	Circuit 1	2C-DC1
	Circuit 2	2C-DC2
	Circuit 1, Switched	2C-SDC1
	Circuit 2, Switched	2C-SDC2
Receptacle Data Color Options	2-digit electrical code	See Beyond Electrical Finishes - Frameless

Specification Example: **BY-FG4DUPLEX.2C-DC1.E4**

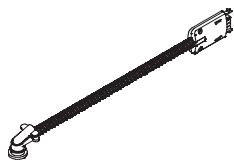

In-feed Cable

Base Model	Description	Specification
BY-FG4INFEED	In-Feed, 4-Wire	BY-FG4INFEED

Option	Specification Description	Specification
Length	72"W	2C-72W
	144"W	2C-144W
	216"W	2C-216W
	300"W	2C-300W

Specification Example: **BY-FG4INFEED.2C-300W**

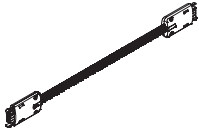

Male-to-Male
Conversion Power
Jumper

Base Model	Description	Specification
BY-FG4MMJUMPER	Male-to-Male Jumper, 4-Wire	BY-FG4MMJUMPER

Specification Example: BY-FG4MMJUMPER

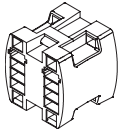

H Connector

Base Model	Description	Specification
BY-FG4HCONN	H-Connector, 4-Wire	BY-FG4HCONN

Specification Example: BY-FG4HCONN

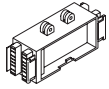

Single

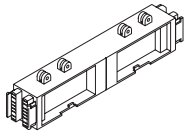

Double

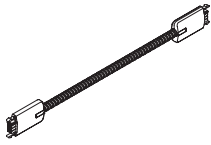

Jumper

Base Model	Description	Specification
BY-FS8PBLOCK	Power Block, 8-Wire	BY-FS8PBLOCK

Option	Specification Description	Specification
Quantity	Single	4C-S
	Double	4C-D

Specification Example: **BY-FS8PBLOCK.4C-S**

Base Model	Description	Specification
BY-FS8JUMPER	Jumper, 8-Wire	BY-FS8JUMPER

Option	Specification Description	Specification
Length	24"W	4C-24W
	27"W	4C-27W
	30"W	4C-30W
	33"W	4C-33W
	36"W	4C-36W
	39"W	4C-39W
	42"W	4C-42W
	45"W	4C-45W
	48"W	4C-48W
	51"W	4C-51W
	54"W	4C-54W
	57"W	4C-57W
	60"W	4C-60W
	63"W	4C-63W
	66"W	4C-66W
	69"W	4C-69W
	72"W	4C-72W
	75"W	4C-75W
	78"W	4C-78W
	81"W	4C-81W
84"W	4C-84W	
87"W	4C-87W	
90"W	4C-90W	
93"W	4C-93W	
96"W	4C-96W	
99"W	4C-99W	
102"W	4C-102W	
105"W	4C-105W	
108"W	4C-108W	
111"W	4C-111W	
114"W	4C-114W	
117"W	4C-117W	
120"W	4C-120W	

Specification Example: **BY-FS8JUMPER.4C-24W**

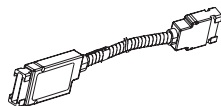

Jumper

Base Model	Description	Specification
BY-FS8PASSTHRU	Pass-Thru without Power Block, 192"	BY-FS8PASSTHRU

Specification Example: **BY-FS8PASSTHRU**

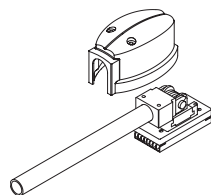

Base In-Feed

Base Model	Description	Specification
BY-FS8BINFEED	Base In-Feed, 8-Wire, 72"	BY-FS8BINFEED

Specification Example: **BY-FS8BINFEED**



Ceiling In-Feed

Base Model	Description	Specification
BY-FS8CINFEED	Ceiling In-Feed, 8-Wire	BY-FS8CINFEED

Option	Specification Description	Specification
Length	144"W	4C-144W
	216"W	4C-216W

Specification Example: **BY-FS8CINFEED.4C-144W**

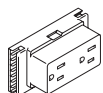

Duplex Receptacle

Base Model	Description	Specification
BY-FS8DUPLEX	Duplex, 8-Wire	BY-FS8DUPLEX

Option	Specification Description	Specification
Circuit Type	Circuit 1	4C-DC1
	Circuit 2	4C-DC2
	Circuit 3	4C-DC3
	Circuit 4 (iso/dedicated)	4C-DC4
	Circuit 3 (2+2)	4C-DC3-2
	Circuit 3 Switched (2+2)	4C-SDC3-2
	Circuit 4 Switched 2+2)	4C-SDC4-2

Receptacle Data Color Options	2-digit electrical code	See Beyond Electrical Finishes - Framed and Solid Panels
-------------------------------	-------------------------	--

Specification Example: **BY-FS8DUPLEX.4C-DC1.E4**

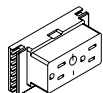

Switched Circuit

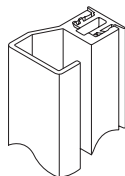

Wire Manager

Base Model	Description	Specification
BY-FSWMANAGER	Wire Manager	BY-FSWMANAGER

Specification Example: **BY-FSWMANAGER**

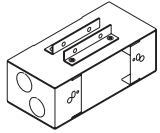

Base Model	Description	Specification
BY-FSCHICAGOBOX	Chicago Code Base Power Electrical Box	BY-FSCHICAGOBOX

Specification Example: **BY-FSCHICAGOBOX**

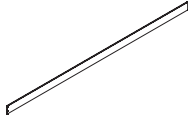

No Ports

Base Model	Description	Specification
BY-FSBTE	Electrical Base Trim	BY-FSBTE

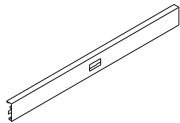

Single Receptacle Port

Configuration ID	Specification Description
Product	Beyond
Product Type	Framed/Solid
Dimension	96 or 120 - Non-Ported
	60" - Single, Double, Single - Chicago, Double - Chicago
	48" - Double with Data
Trim Type	Base
Trim Use	Straight
	Straight Ported
Trim Style	Electrical
Port Quantity	Non-Ported
	Single
	Double
	Double with Data
	Single - Chicago
	Double - Chicago
Finish Color	Painted or Anodized Finishes

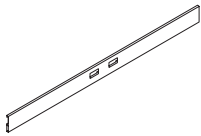

Double Receptacle Port

Option	Specification Description	Specification
Paint Color Selection	3-digit painted or anodized finish	See Beyond Frame Finishes

Specification Example: **BY-FSBTE.####.P8X**

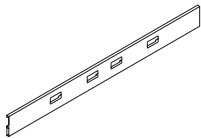

Double Receptacle Ports with Double Data Ports

BEYOND TABLE OF CONTENTS

BEYOND FINISHES & FABRICS

BEYOND PANELS & TRIM

BEYOND DOORS

BEYOND CONNECTORS

BEYOND ELECTRICAL & DATA

BEYOND FRAMELESS PRIVACY TILE SYSTEM

BEYOND VIZ

Privacy tiles can be added to frameless glass applications to add visual privacy. There are two ways to add privacy tiles to the system — through rail-mounting or through button-mounting. Both methods are described in the following pages. All applications of frameless privacy tiles and distraction markers must use tempered perforated glass to support the hanging tiles.

- Perforated glass wall panels are available in standard widths of 40", 42", and 48".
- Glass must be perforated to accept privacy tiles or distraction markers.
- Perforated glass wall panels can be rotated to have perforations on either edge at install (non-handed).
- Perforation patterns are designed to accept specific privacy tile configurations and are available in both single and double sets.

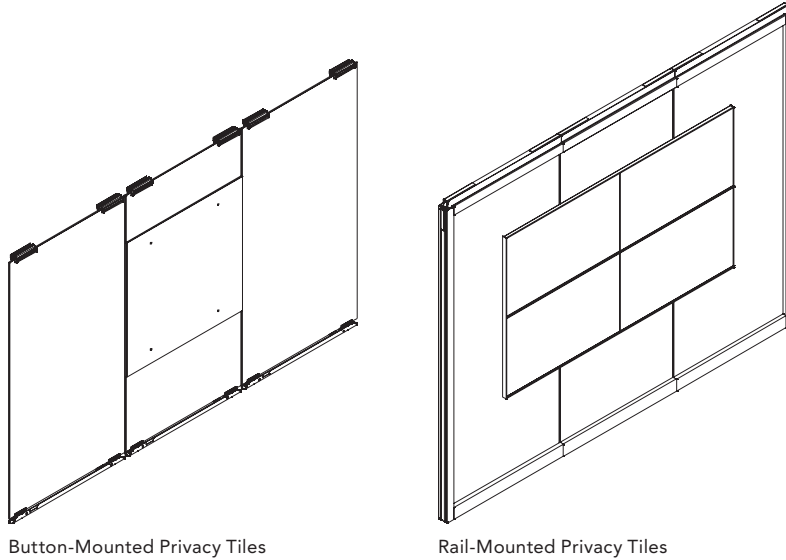

Button-Mounted Privacy Tiles

Rail-Mounted Privacy Tiles

Button-Mounted

- The button-mounted privacy tile system suspends glass tiles from buttons attached through perforations in the glass.
 - Note that button-mounted privacy tiles cannot be adjacent to a frameless wall channel or frameless adapter due to glass installation issues (wall channels and adapters cannot accept the privacy tile glass).
- Buttons are available in the following configurations:
 - Single-sided to suspend a tile on one side of the frameless perforated glass wall.
 - Double-sided to suspend tiles on both sides of the frameless perforated glass wall.
 - As distraction markers or to fill a perforation when privacy tiles are removed.

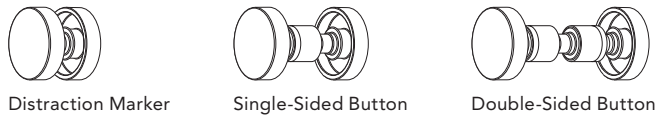

Distraction Marker

Single-Sided Button

Double-Sided Button

Button-Mounted Tiles:

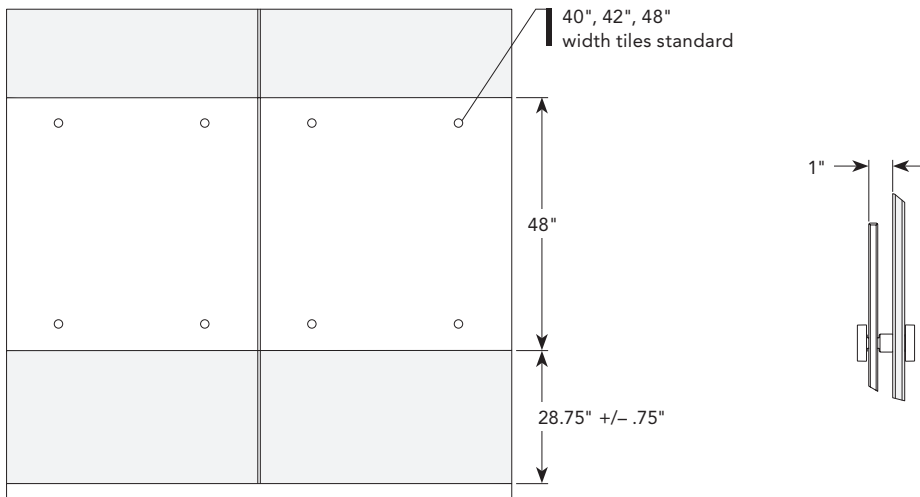

Rail-Mounted

- The rail-mounted privacy tile system utilizes a wall tile kit and tiles that attach to rails mounted to frameless perforated glass panels.
 - Privacy tiles are available in a variety of materials including veneer, laminate, fabric, and markerboard glass. Markerboard glass for the rail-mounted privacy tile system is laminated. For custom colors, please contact Allsteel prior to submitting a special request.
 - Rail-mounted privacy tiles must always be used in double-sided applications, meaning that privacy tiles must be installed on both sides of the glass.
- Rail and trim kits include the extrusions and support rails to hang the tiles from the frameless perforated glass panels.
 - Kits are available in 80", 84", and 96" widths. Kits are 1½" deep and install flush with the face of the base trim.
 - Fabric, veneer, and laminate tiles always require QTY (2) tiles in width (i.e., QTY (2) 40"W tiles are required for the 80"W tile kit).
 - Markerboard glass tiles are produced in full widths with QTY (1) tile.
 - Rail and trim kits include extrusions that wrap the exterior edge of the wall tiles to produce a finished edge.
 - Individual rails mount through the glass perforations and the tiles clip to these rails. The rails contain an integral channel that also supports shelves.
 - Shelves are available in glass.
- Multiple privacy tile kits may be mounted adjacent to each other but only with floating or "with modesty" options. Not allowed with "to the base" options.
 - When mounting adjacent privacy tile kits, wall panel widths must be the same width dimension.
- Overhead mounting is not allowed.
- TV Mount height trim kits are available for hanging a television on frameless privacy tiles. Hard-surface tiles must be used behind the television. Fabric or markerboard tiles are available on the opposite side of the television. [See Technology integration for more details.](#)
- Frameless Privacy Tiles – Rail-Mounted
 - To order rail-mounted privacy tiles, perforated glass, a privacy tile kit, and tiles need to be ordered.
 - Rail-mounted will be available in existing configurations:
 - Single
 - Single with Modesty
 - Double to the Base
 - Double Floating
 - Double with Modesty
 - Triple to the Base
 - Markerboard
 - Markerboard with Modesty
 - Triple to the Base with Markerboard
 - TV Mount Height
 - TV Mount Height with Markerboard
 - Specification rules:
 - Panel heights can go down to 86". The exception is the privacy tile configuration for TV mount height. 95" is the minimum panel height.
 - Tile widths and heights are unchanged.
 - Perforated glass panel is separate base model.

- Rail-mounted privacy tiles can be specified in two- or three-panel modules.

– Two-Panel Module

- The two-panel module is best for movability and flexibility.
- In this application, privacy tile kits are on module with two frameless perforated glass panels. The tile kit width must match the sum of the two panels (i.e., 84" tile kit mounts on module with QTY (2) 42"W panels).
- Utilize the double perforation patterns for both panels.

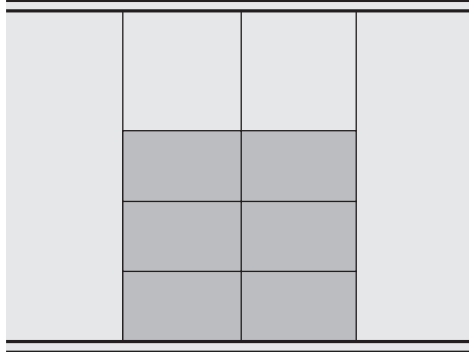

Example of Two-Panel Module (Triple to the Base)

– Three-Panel Module

- The three-panel module creates a unique aesthetic.
- In this application, privacy tile kits are centered on the middle frameless perforated glass panel and extend halfway into each adjacent panel.
- Utilize the double perforation patterns for the center panel.
- Utilize the single perforation patterns for the panels adjacent to the center panel.

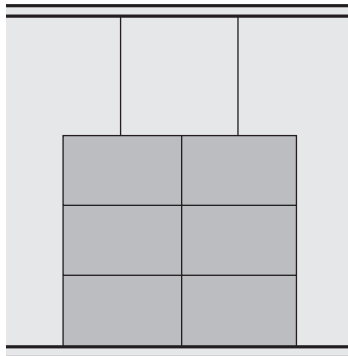

Example of Three-Panel Module (Triple to the Base)

Glass Perforation Patterns

- Perforation patterns are available in single (one vertical set of perforations) and double (two vertical sets of perforations) applications.
 - A single perforation set is used when only one side of the wall panel needs to be perforated. Rail-mounted tiles specified using the three-panel module utilize single perforation sets on the outer two frameless glass wall panels with double perforation sets on the center middle frameless glass wall panel.
 - Specify single on the panels to the left and right of the middle segment.
 - Single perforation patterns provide one set of perforations 10" from both sides of the glass.
 - A double perforation set is used when the two-panel module is specified for rail-mounted privacy tiles or for the middle segment of the three-panel module.
 - Double perforation patterns provide two sets of perforations 10" from both sides of the glass.
 - Privacy tiles must use tempered glass.

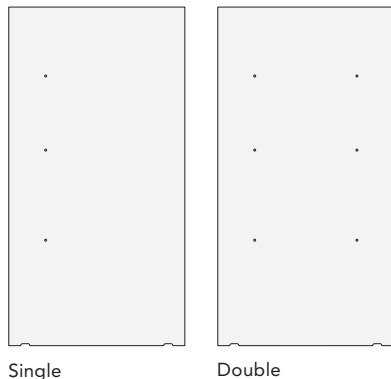

Perforation Patterns:

Pattern A1, Single Perforations: Single or Double to the Base
Pattern A1, Double Perforations: Single or Double to the Base
Pattern A2, Single Perforations: Double Floating, Triple to the Base, Markerboard or Triple to the Base with Markerboard
Pattern A2, Double Perforations: Double Floating, Triple to the Base, Markerboard or Triple to the Base with Markerboard
Pattern A3, Single Perforations: Single with Modesty
Pattern A3, Double Perforations: Single with Modesty
Pattern A4, Single Perforations: Double with Modesty or Markerboard with Modesty
Pattern A4, Double Perforations: Double with Modesty or Markerboard with Modesty
Pattern A5, Single Perforations: Button Mount
Pattern A5, Double Perforations: Button Mount
Pattern A6, Single Perforations: Visual Distraction Markers at 54.67" AFF nominal
Pattern A6, Double Perforations: Visual Distraction Markers at 54.67" AFF nominal
Pattern A7, Single Perforations: TV Mount Height and TV Mount Height with Markerboard - Coming Soon!
Pattern A7, Double Perforations: TV Mount Height and TV Mount Height with Markerboard - Coming Soon!

Perforation Patterns – continued:



Privacy Tile Configuration Options:

Button Mount

40W – 42W – 48W

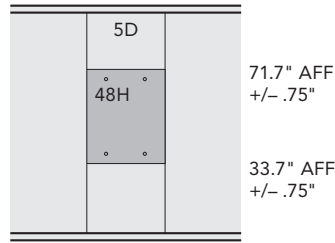

Single or Double-Sided

Visual Distraction Markers

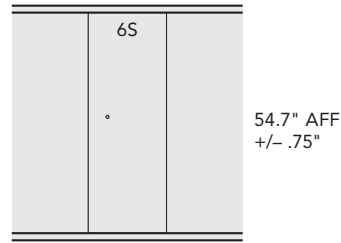

Single

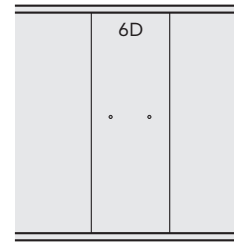

Double

Rail Mount – Two-Panel Module

80W – 84W – 96W

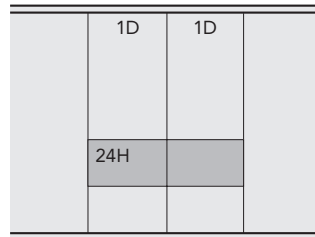

Single

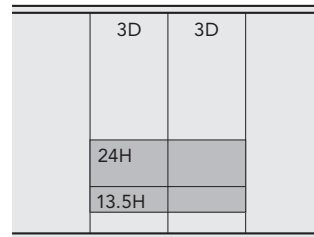

Single with Modesty

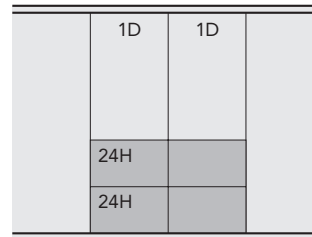

Double to the Base

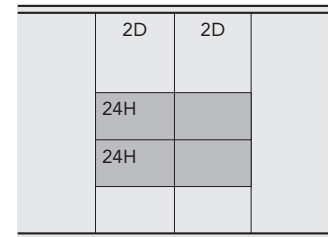

Double Floating

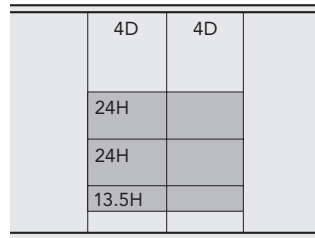

Double with Modesty

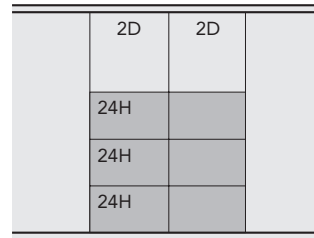

Triple to the Base

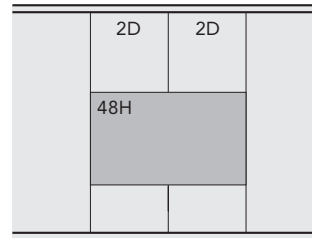

Markerboard

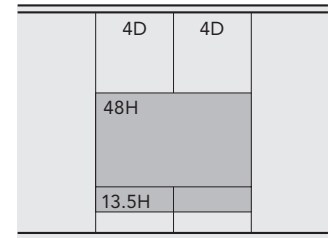

Markerboard with Modesty

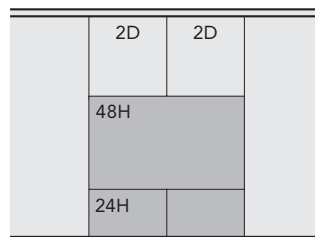

Triple to the Base
with Markerboard

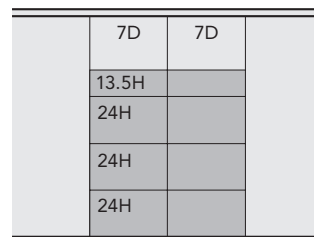

TV Mount Height*

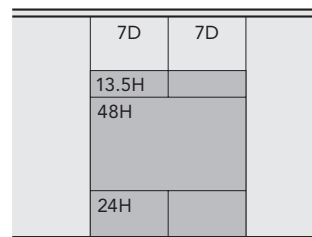

TV Mount Height* with
Markerboard on reverse side

*TV Mount Height configurations require additional components and coordination to support technology integration.

Frameless Privacy Tile System

Beyond®

Rail Mount – Three-Panel Module

80W – 84W – 96W

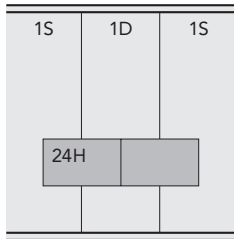

Single

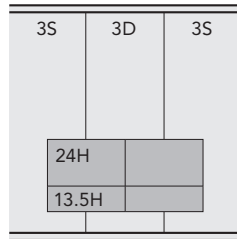

Single with Modesty

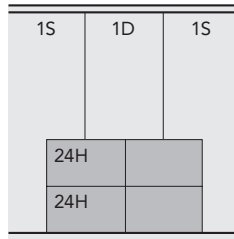

Double to the Base

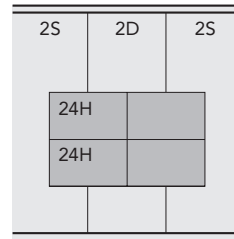

Double Floating

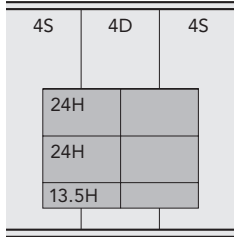

Double with Modesty

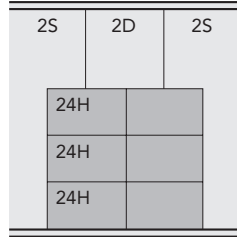

Triple to the Base

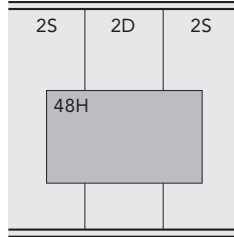

Markerboard

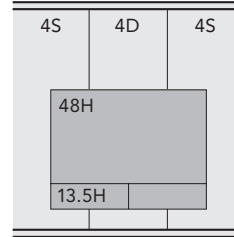

Markerboard with Modesty

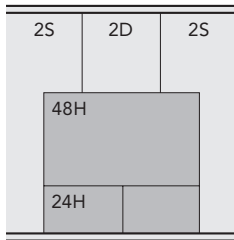

Triple to the Base
with Markerboard

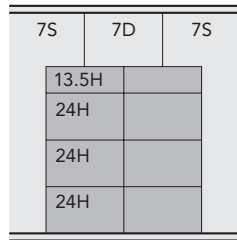

TV Mount Height*

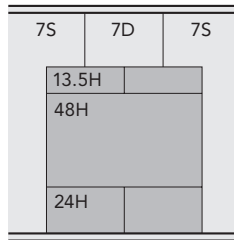

TV Mount Height*
with Markerboard on reverse side

*TV Mount Height configurations require additional components and coordination to support technology integration.

TV Mounting on Frameless Glass Privacy Tiles

Utilize the TV mount height privacy tile kit to add a TV to frameless glass walls.

Frameless Glass Walls 4-Trac Duplex Mounting:

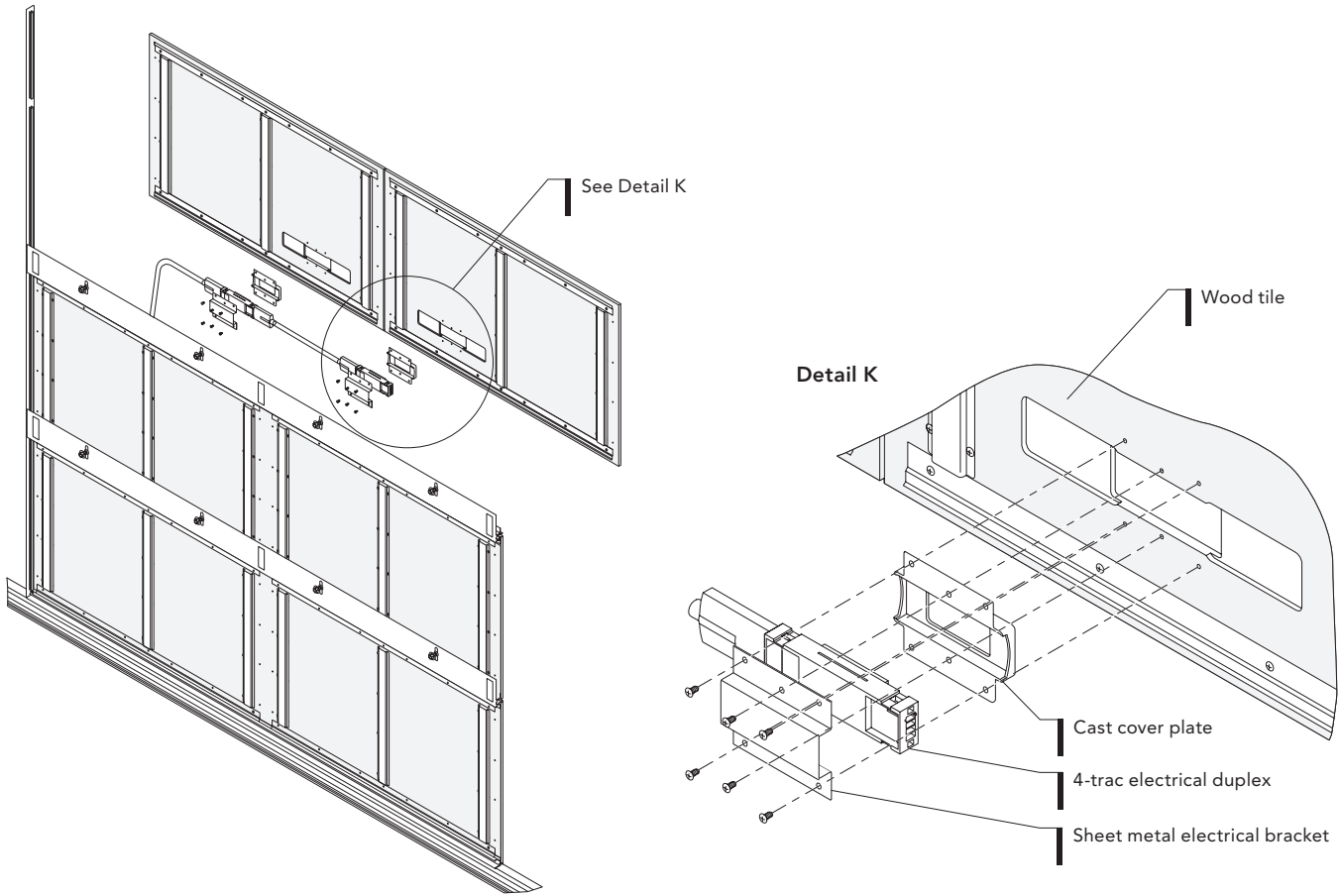

- Specify the TV mount height or TV mount height with markerboard configurations (see following pages for details).
- Utilizes perforated frameless glass walls with the 7S or 7D perforation patterns.
- Frameless glass 4-wire, 2-circuit modular electrical is required to route electrical behind the privacy tiles to bring power to the TV. Specify in-feed, jumpers, and receptacles.
 - For adding two receptacles, specify a 24" jumper to connect the two together.
- Privacy tiles must be hard surface (strata-wood veneer or laminate) to support the TV mount. Fabric or glass tiles cannot be used on the side where the television is mounted. Laminate or veneer tiles can be specified with an electrical port in the bottom-right of bottom-left corner to support electrical and data requirements as needed.
- Specify the TV mounting plate and grommet (model BY-FGTVPLATE) and TV bracket (model BY-FGTVBRACKET).
- To jump from an H-connector or receptacle in base to receptacle behind TV, specify a 90" L-jumper.

Frameless Glass Walls TV Bracketry Mounting:

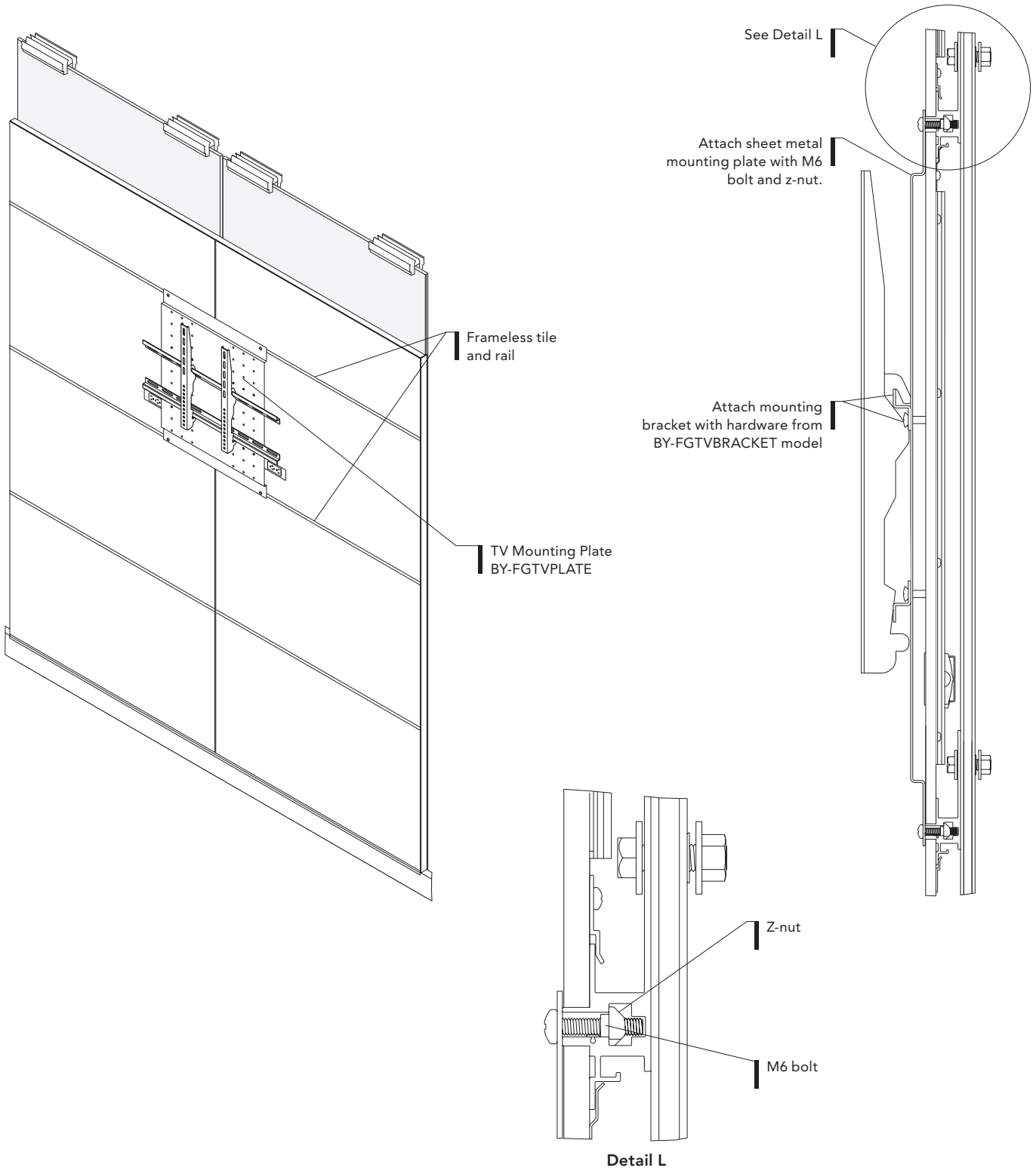

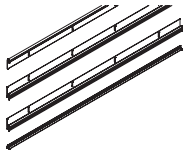

Double to the Base - Trim Kit

Base Model	Description	Specification
BY-FGRTRIMKIT	Rail-Mounted Privacy Trim Kit	BY-FGRTRIMKIT
Configuration ID	Specification Description	
Application	Rail Tile Kit	
Product Type	Two Panel Base Two Panel Floating Three Panel Base Three Panel Floating	
Privacy Tile Configuration	Single Single with Modesty Double to the Base Double Floating Double with Modesty Triple to the Base Markerboard Markerboard with Modesty Triple to the Base with Markerboard TV Mount Height TV Mount Height with Markerboard	
Rail Configuration	Two Rail Three Rail Four Rail Five Rail Three Rail Markerboard Four Rail Markerboard	
Width	80"W 84"W 96"W	
Height	24" 37½" 48" 61½" 72" 85½"	
Finish Color	See Beyond Frame Finishes	

Specification Example: BY-FGRTRIMKIT.####

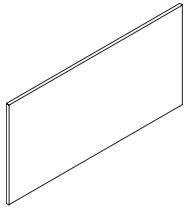

Base Model	Description	Specification
BY-FGRTILEFAB	Rail-Mounted Fabric Tile	BY-FGRTILEFAB
Configuration ID	Specification Description	
Application	Rail Tile	
Width	40"W 42"W 48"W	
Height	13.5"H 24"H	
Tile Type	Fabric	
Tile Finish	See Beyond Fabric Finishes	

Option	Specification Description	Specification
Fabric Grade Selection and Color Option	Beyond Fabric	See Beyond Fabric Finishes

Specification Example: BY-FGRTILEFAB.####.APN911

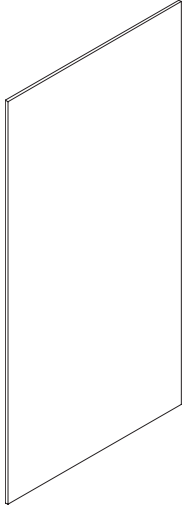

Base Model	Description	Specification
BY-FGRTILEVEN	Rail-Mounted Veneer Tile	BY-FGRTILEVEN

Configuration ID	Specification Description	
Application	Rail Tile	
Width	40"W 42"W 48"W	
Height	13.5"H 24"H	
Tile Type	Veneer	
FSC	FSC Certified Not FSC Certified	FSC X
Tile Finish	See Beyond Veneer Finishes	
Port Location	Will populate if port is selected Left Right	

Option	Specification Description	Specification
FSC Option	FSC Certified Standard Wood (Not FSC Certified)	FSC X
Veneer Grade and Color Option	Beyond Veneer Finishes	See Beyond Veneer Finishes

Specification Example: BY-FGRTILEVEN.####.SC701

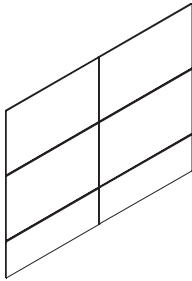

Base Model	Description	Specification
BY-FGTILEVSETM	Rail-Mounted Natural Veneer Privacy Set with Modesty	BY-FGTILEVSETM

Configuration ID	Specification Description	
Application	Rail Tile	
Width	80"W 84"W 96"W	
Height	13.5"H 37.5"H 61.5"	
Tile Type	Veneer	
FSC	FSC Certified Not FSC Certified	FSC X
Tile Finish	See Beyond Veneer Finishes	

Option	Specification Description	Specification
FSC Option	FSC Certified Standard Wood (Not FSC Certified)	FSC X
Veneer Grade and Color Option	Beyond Veneer Finishes	See Beyond Veneer Finishes

Specification Example: BY-FGTILEVSETM.####.NC701

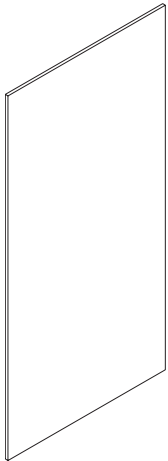
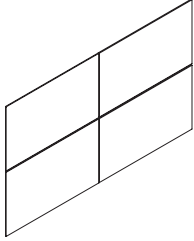
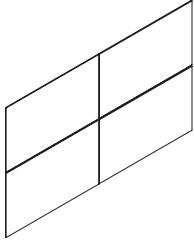

Base Model	Description	Specification
BY-FGTILEVSETF	Rail-Mounted Natural Veneer Privacy Set, Floating or Base	BY-FGTILEVSETF

Configuration ID	Specification Description	Specification
Application	Rail Tile	
Width	80"W 84"W 96"W	
Height	24"H 48"H 72"H	
Tile Type	Veneer	
FSC	FSC Certified Not FSC Certified	FSC X
Tile Finish	See Beyond Veneer Finishes	

Option	Specification Description	Specification
FSC Option	FSC Certified Standard Wood (Not FSC Certified)	FSC X
Veneer Grade and Color Option	Beyond Veneer Finishes	See Beyond Veneer Finishes

Specification Example: BY-FGTILEVSETF.####.NC701

Base Model	Description	Specification
BY-FGRTILELAM	Rail-Mounted Laminate Tile	BY-FGRTILELAM

Configuration ID	Specification Description	Specification
Application	Rail Tile	
Product Type	Rail Tile	
Width	40"W 42"W 48"W	
Height	13.5"H 24"H	
Tile Type	Laminate	
FSC	FSC Certified Not FSC Certified	FSC X
Tile Finish	See Beyond Laminate Finishes	
Port Location	Will populate if port is selected Left Right	

Option	Specification Description	Specification
FSC Option	FSC Certified Standard Wood (Not FSC Certified)	FSC X
Laminate Grade and Color Option	Beyond Laminate Finishes	See Beyond Laminate Finishes

Specification Example: BY-FGRTILELAM.####.LM13

Frameless Privacy Tile System

Beyond® — Rail-Mounted Components

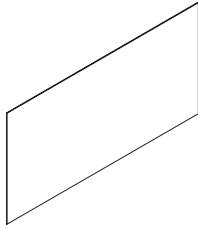

Base Model	Description	Specification
BY-FGRTILEGMB	Rail-Mounted Glass Markerboard Tile	BY-FGRTILEGMB

Configuration ID	Specification Description
Application	Rail Tile
Width	80"W 84"W 96"W
Height	24"H 48"H
Tile Type	Glass Markerboard
Tile Finish	See below

Option	Specification Description	Specification
Glass Selection	5/16" Laminated, Low Iron, Markerboard, Magnetic	QW

Specification Example: BY-FGRTILEGMB.####.QW

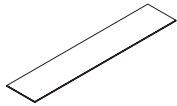

Shelf

Base Model	Description	Specification
BY-FGRSHELF	Rail-Mounted Glass Shelf	BY-FGRSHELF

Option	Specification Description	Specification
Width	24"W 40"W 42"W 48"W	24 40 42 48
Glass Selection	QA: 1/4" Tempered, Clear	QA

Specification Example: BY-FGRSHELF.24.QA

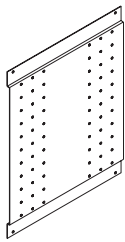

Plate

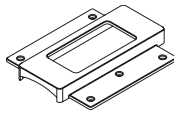

Grommet

Base Model	Description	Specification
BY-FGTVPLATE	TV Plate and Grommet	BY-FGTVPLATE

Specification Example: BY-FGTVPLATE

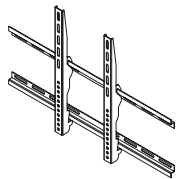

Bracket

Base Model	Description	Specification
BY-FGTVBRACKET	TV Mounting Bracket	BY-FGTVBRACKET

Specification Example: BY-FGTVBRACKET

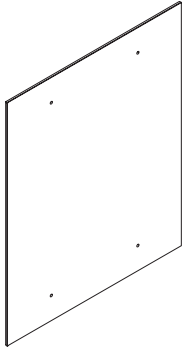

Base Model	Description	Specification
BY-FGBMTILE	Button-Mounted Privacy Tile (Laminated Glass)	BY-FGBMTILE

Configuration ID	Specification Description
Application	Button Tile
Width	40"W 42"W 48"W
Height	48"H
Hand	Left Right
Tile Type	Glass
Tile Finish	See below

Option	Specification Description	Specification
Glass Selection	TE: 3/8" Laminated, Clear, Translucent White	TE
	TF: 3/8" Laminated, Low Iron, Markerboard	TF
	TL: 3/8" Laminated, Clear, Markerboard	TL

Specification Example: **BY-FGBMTILE.####.TE**

Base Model	Description	Specification
BY-FGBUTTON	Privacy Tile Button	BY-FGBUTTON

Configuration ID	Specification Description
Application	Button
Mounting Type	Distraction Marker Single Button Double Button
Finish Color	See Beyond Frame Finishes

Option	Specification Description	Specification
Paint Color Selection	3-digit painted or anodized finish	See Beyond Frame Finishes

Specification Example: **BY-FGBUTTON.####.P8X**

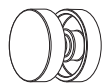

Distraction Marker

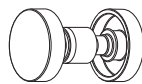

Button for Single-sided

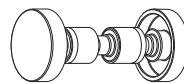

Button for Double-sided

Working with Beyond Viz

Beyond Viz is a markerboard screening application that allows users to reclaim vertical real estate for collaborative use by creating visual persistence and zones for teams. These markerboard screens come in a variety of sizes with a new post option for incorporating modular electrical.

- Viz Markerboard Module
 - Order markerboard and markerboard trim in the following dimensions (nominal dimension of the markerboard):
 - Width options: 48", 54", 60", 66", 72", 78", 84", 90", 96", 102", 108", 114", 120"
 - Markerboard Height options: 48", 54", 60"
 - Glass Finish: 1/4" Low-Iron, Magnetic, White Markerboard
 - Trim: All Beyond trim finishes

All Beyond Viz markerboard screens must be connected to a post on both sides utilizing Beyond zippers. Posts must be anchored to the floor and ceiling. Brackets attach to posts which are then anchored into place. If under ceiling grid, posts must be anchored above the grid which may involve cutting through ceiling tiles. Multiple Viz screens can be connected together using zippers that connect the screens to posts. Inline, two-way and three-way connections are possible. Note that there are options for post bracketry that coordinate with the post type and installation scenario. Utilize QTY (2) zippers for each connection point to connect Viz trim to post. All trim and posts utilize standard Beyond trim finishes.

- Posts
 - Utilize standard Beyond posts with access trim for inline, two-way, or three-way connections
 - A new inline post option is available for hardwired electrical. Post comes with an option to incorporate hardwired electrical with a port for a receptacle at 18" AFF on one face with a removable faceplate on the opposite side of the post.
 - A new inline post option is available for modular electrical. Post comes with a port for a receptacle at 18" AFF on one face and removable faceplate on the opposite side of post.
 - Utilizes 4-wire, 2-circuit electrical (note: this is also known as the Beyond Frameless modular electrical system)
 - Duplex receptacle should be specified at 18" AFF
 - Circuit 1 or 2
 - Standard 2-circuit duplex finishes
 - Ceiling infeed connection only
 - Mounting Brackets
 - Specify QTY (1) mounting bracket per post. Bracket model contains brackets for the floor and ceiling for (1) post.
 - For an inline post, there are two types of mounting brackets – a flat bracket model and a u-channel bracket model. These model descriptions describe the bracket installed at the top of the post, but note that each model comes with brackets for the top and bottom of the post. The flat bracket model contains (1) flat bracket for the ceiling and (1) u-channel bracket for the floor. The u-channel bracket model contains (2) u-channel brackets for use at the ceiling and floor.
 - For a two-way or three-way post, specify an L and T bracket model. This model contains (1) L/T plate that installs at the top of the post and (1) u-channel bracket that installs at the bottom of the post.
 - Zippers
 - Utilize standard Beyond zippers to connect posts to Viz screens
 - QTY (2) zippers required to connect Viz trim to (1) post

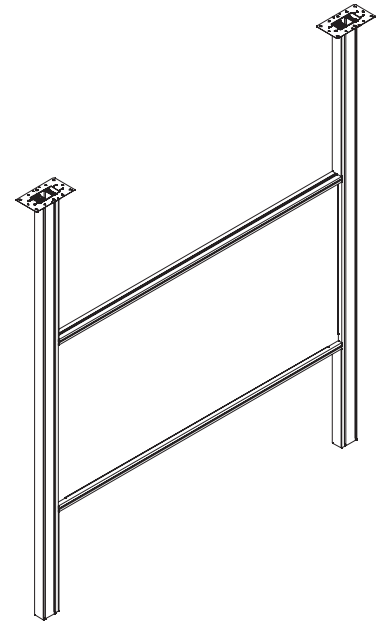

- Finished Ends
 - Posts that do not connect to a Viz markerboard screen on both sides must be specified with a finished end.
 - Two options for finished ends
 - Uniform finished end — the actual dimension is $1\frac{5}{32}$ "W. Planning dimension is $1\frac{1}{4}$ "W. Height is available 86" - 120" in $\frac{1}{4}$ " increments. Height is available 12" - 48" in $\frac{1}{4}$ " increments for stacking.
 - Narrow finished end — the actual dimension is $\frac{5}{16}$ "W. Planning dimension is $\frac{1}{8}$ "W. Height is 120".
 - If intent is to have width of marker board trim and width of finished end match, specify uniform finished end.
- To add finished ends to posts with stackers:
 - When using the uniform finished end, specify QTY (1) finished end for the full height post and QTY (1) stacking finished end for the stacking post. Both the full height and stacking finished end models are standard Beyond models.
 - For the narrow finished end, specify (2) narrow finished ends. One finished end will be utilized on the full height post and the other finished end will be cut to size in the field to fit on the stacking post.
- Stacking Posts
 - To bring markerboard modules to heights above 10ft, utilize stacking posts. Stacking posts are standard Beyond models that range from 2ft to 4ft, allowing Viz modules to grow to 14 ft overall.
 - Inline, two-way and three-way stacking posts with access trim are possible
 - Stacking posts must be connected to posts via splice kits
 - Specify QTY (1) splice kit per stacking post
 - Viz stacking trim must be specified (ETO-AP-BY-VIZSTRIM) to finish off the Viz module when stacking posts are specified. Stacking trim comes in 10ft lengths. QTY (1) can be utilized for (1) markerboard module. Trim can be cut to size in the field and installed on both sides of the inside of the Viz module to finish the stacking posts.

Bracketry: Inline Posts

Top Connection

Flat Bracket

The flat bracket can encompass post or sit flush with top of inline post. Two L-shaped brackets attach to the flat bracket to connect the bracket to the inline post and can rest above or below the flat bracket. Bracket works with inline posts and with uniform and low profile finished ends.

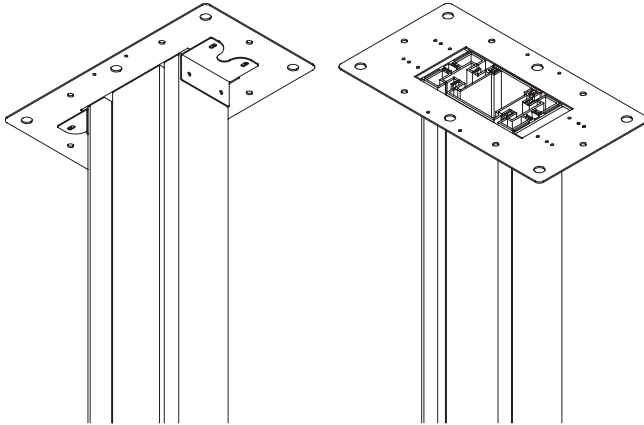

Flat Bracket

U-Channel Bracket

The u-channel bracket can be used at the ceiling connection. U-channel bracket slides into the top of the post, is secured in place, and sits 1/16" proud of the top of the inline post to allow for installation. Bracket works with uniform and low profile finished ends.

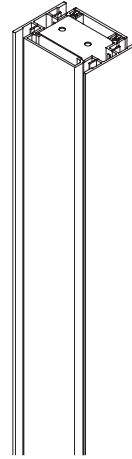

U-Channel Bracket

Bottom Connection

U-Channel Bracket

The u-channel bracket must always be used at the floor connection. U-channel bracket slides into the bottom of the inline post, is secured in place, and sits 1/16" proud of the bottom of the inline post.

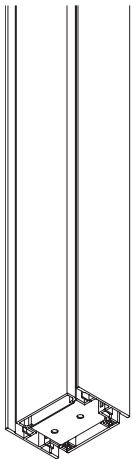

U-Channel Bracket

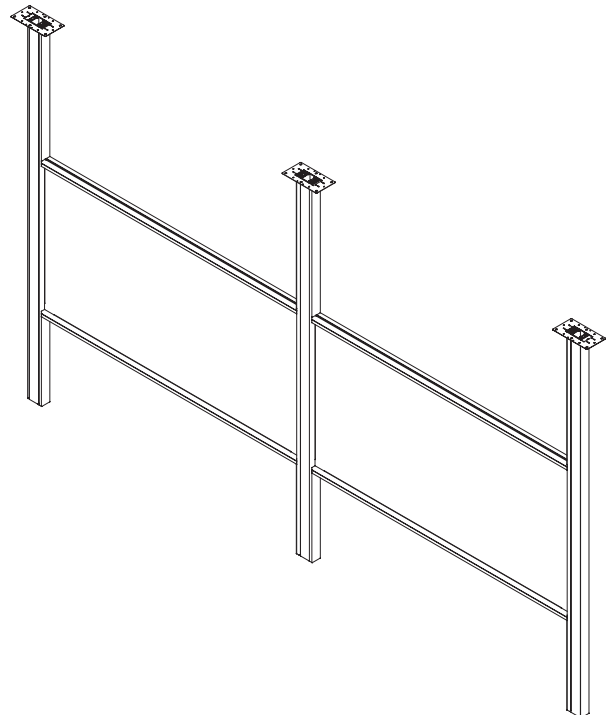

Bracketry: Two- & Three-Way Posts

Top Connection

Flat Bracket

The flat bracket for an L,T connection can encompass posts or sit flush with top of post. Two L-shaped brackets attach to the flat bracket to connect the bracket to the two-way or three-way post and can rest above or below the flat bracket. Bracket works with uniform and low profile finished ends.

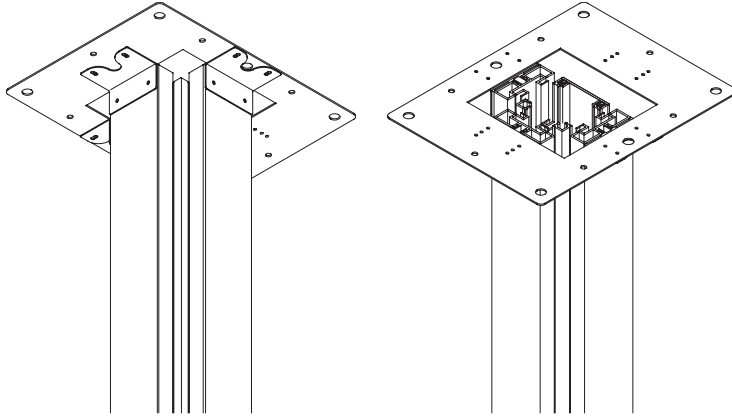

Three-Way Post

U-Channel Bracket

The u-channel bracket can be used at the ceiling connection. U-channel bracket slides into the top of the post, is secured in place, and sits 1/16" proud of the top of the inline post to allow for installation. Bracket works with uniform and low profile finished ends.

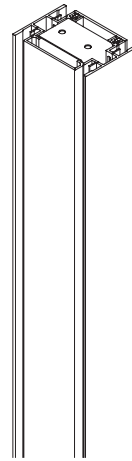

U-Channel Bracket

Bottom Connection

U-Channel Bracket

The u-channel bracket must always be used at the floor connection. U-channel bracket slides into the bottom of the post, is secured in place, and sits 1/16" proud of the bottom of the post.

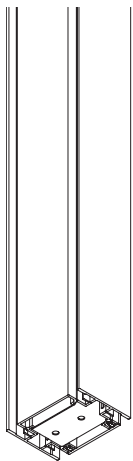

U-Channel Bracket

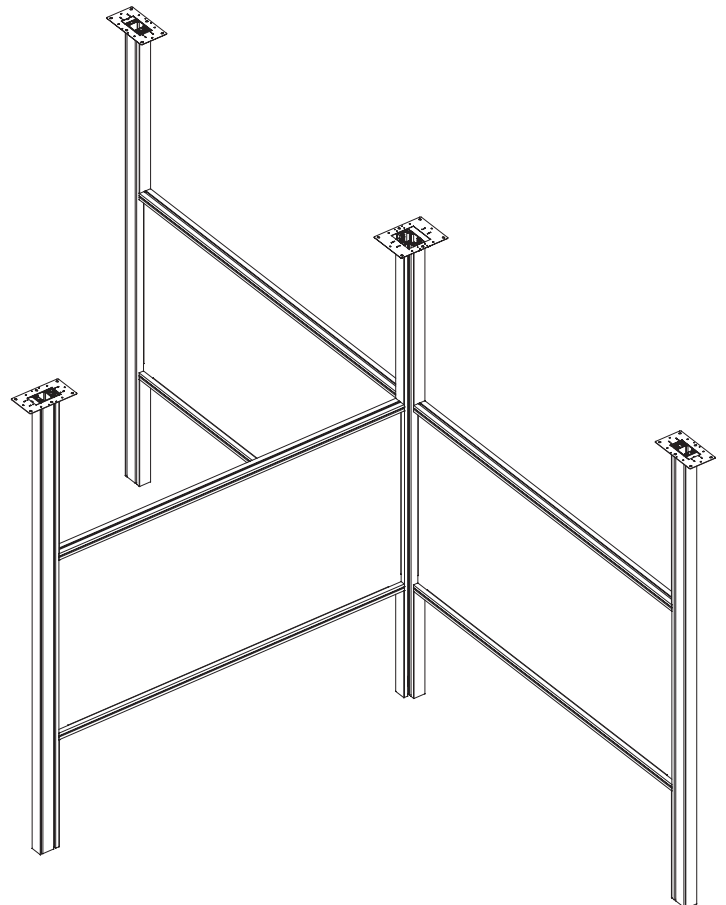

Attachment Methods & Materials

The project architect is ultimately responsible for code compliance to International Building Code and other code requirements. Viz posts must be anchored to the floor and ceiling. When utilizing u-channel brackets into a soffit, blocking is required.

Top Connection

Flat Bracket

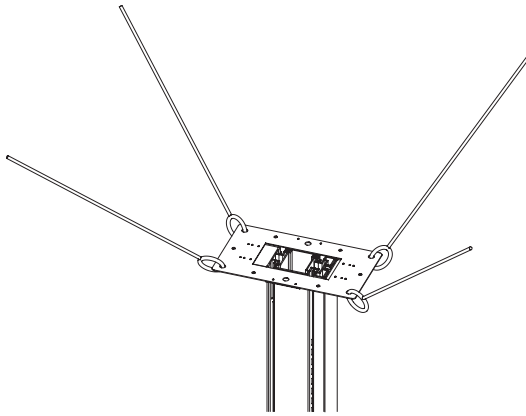

Attaching splay wire to ceiling bracket

Splay wire can attach to bracket holes. A minimum of (4) wires required per bracket. $\frac{3}{32}$ " diameter aircraft cable 7x19 strand core recommended. Attach to eyebolt with medium duty wire rope thimble.

Post can also be attached to deck using kickers.

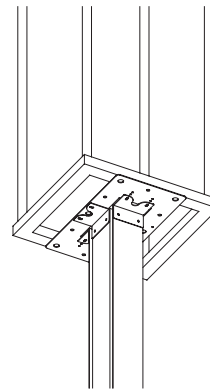
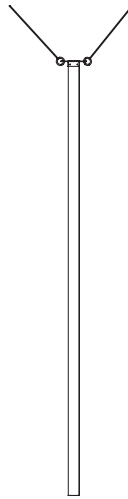

Building trapeze around obstruction to ceiling bracket

Unistrut material can be attached to Viz flat bracket to work around an overhead obstruction.

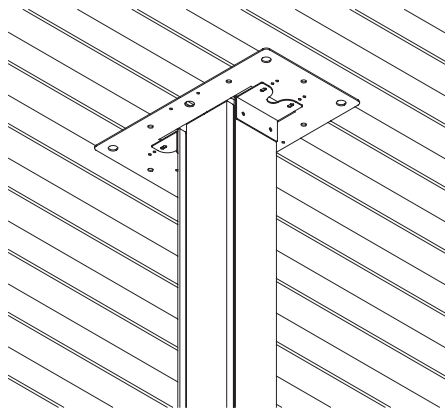
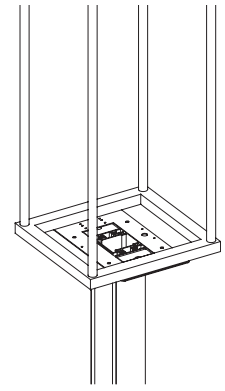

Attaching bracket directly to building structure

Bracket can attach directly to building structure – to the ceiling deck or to an alternative structure.

U-Channel Bracket

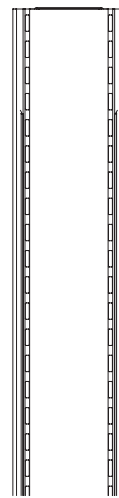

Attaching u-channel bracket to building structure/soffit

Blocking is required when utilizing u-channel bracket under soffit. A minimum of $\frac{1}{2}$ " (0.5") is needed on either side of each screw. Bracket sits $\frac{1}{16}$ " proud of the post.

Attachment Methods & Materials

Bottom Connection

U-Channel Bracket

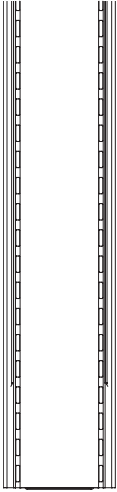

Attaching u-channel bracket to floor

The u-channel bracket must be anchored into the floor. Bracket sits 1/16" proud of the post.

Base Model	Description	Specification
ETO-AP-BY-VIZMBGL48	Viz Markerboard Glass, 48"H	ETO-AP-BY-VIZMBGL48

Option	Specification Description	Specification
Custom Number	Custom Model Number	M516901
Width	48"	04800W
	54"	05400W
	60"	06000W
	66"	06600W
	72"	07200W
	78"	07800W
	84"	08400W
	90"	09000W
	96"	09600W
	102"	10200W
	108"	10800W
	114"	11400W
120"	12000W	

Specification Example: ETO-AP-BY-VIZMBGL48.M516901.04800W

Base Model	Description	Specification
ETO-AP-BY-VIZMBGL54	Viz Markerboard Glass, 54"H	ETO-AP-BY-VIZMBGL54

Option	Specification Description	Specification
Custom Number	Custom Model Number	M516902
Width	48"	04800W
	54"	05400W
	60"	06000W
	66"	06600W
	72"	07200W
	78"	07800W
	84"	08400W
	90"	09000W
	96"	09600W
	102"	10200W
	108"	10800W
	114"	11400W
120"	12000W	

Specification Example: ETO-AP-BY-VIZMBGL54.M516902.04800W

Base Model	Description	Specification
ETO-AP-BY-VIZMBGL60	Viz Markerboard Glass, 60"H	ETO-AP-BY-VIZMBGL60

Option	Specification Description	Specification
Custom Number	Custom Model Number	M516903
Width	48"	04800W
	54"	05400W
	60"	06000W
	66"	06600W
	72"	07200W
	78"	07800W
	84"	08400W
	90"	09000W
	96"	09600W
	102"	10200W
	108"	10800W
	114"	11400W
	120"	12000W

Specification Example: ETO-AP-BY-VIZMBGL60.M516903.04800W

Base Model	Description	Specification
ETO-AP-BY-VIZTRIM48	Viz Markerboard Frame and Trim, 48"H	ETO-AP-BY-VIZTRIM48

Option	Specification Description	Specification
Custom Number	Custom Model Number	M516904
Width	48"	04800W
	54"	05400W
	60"	06000W
	66"	06600W
	72"	07200W
	78"	07800W
	84"	08400W
	90"	09000W
	96"	09600W
	102"	10200W
	108"	10800W
	114"	11400W
	120"	12000W
Trim Finish	Anodized, Clear	SAL
	Painted - See Beyond frame finishes	---

Specification Example: ETO-AP-BY-VIZTRIM48.M516904.04800W.SAL

Base Model	Description	Specification
ETO-AP-BY-VIZTRIM54	Viz Markerboard Frame and Trim, 54"H	ETO-AP-BY-VIZTRIM54
Option	Specification Description	Specification
Custom Number	Custom Model Number	M516905
Width	48"	04800W
	54"	05400W
	60"	06000W
	66"	06600W
	72"	07200W
	78"	07800W
	84"	08400W
	90"	09000W
	96"	09600W
	102"	10200W
	108"	10800W
	114"	11400W
Trim Finish	Anodized, Clear	SAL
	Painted - See Beyond frame finishes	---

Specification Example: ETO-AP-BY-VIZTRIM54.M516905.04800W.SAL

Base Model	Description	Specification
ETO-AP-BY-VIZTRIM60	Viz Markerboard Frame and Trim, 60"H	ETO-AP-BY-VIZTRIM60
Option	Specification Description	Specification
Custom Number	Custom Model Number	M516906
Width	48"	04800W
	54"	05400W
	60"	06000W
	66"	06600W
	72"	07200W
	78"	07800W
	84"	08400W
	90"	09000W
	96"	09600W
	102"	10200W
	108"	10800W
	114"	11400W
Trim Finish	Anodized, Clear	SAL
	Painted - See Beyond frame finishes	---

Specification Example: ETO-AP-BY-VIZTRIM60.M516906.04800W.SAL

Base Model	Description	Specification
ETO-AP-BY-VIZEPOST	Beyond Viz Access Post, Mod Electrical, 18" AFF	ETO-AP-BY-VIZEPOST

Option	Specification Description	Specification
Custom Number	Custom Model Number	M516907
Trim Finish	Anodized, Clear	SAL
	Painted - See Beyond frame finishes	---

Specification Example: ETO-AP-BY-VIZEPOST.M516907.SAL

Base Model	Description	Specification
ETO-AP-BY-VIZEHPOST	Beyond Viz Access Post, HW Electrical, 18" AFF	ETO-AP-BY-VIZEHPOST

Option	Specification Description	Specification
Custom Number	Custom Model Number	M516914
Trim Finish	Anodized, Clear	SAL
	Painted - See Beyond frame finishes	---

Specification Example: ETO-AP-BY-VIZEHPOST.M516914.SAL

Base Model	Description	Specification
ETO-AP-BY-VIZFMOUNT	Beyond Viz Floor/Ceiling Flat Mounting Brackets	ETO-AP-BY-VIZFMOUNT

Option	Specification Description	Specification
Custom Number	Custom Model Number	M516908
Trim Finish	Anodized, Clear	SAL
	Painted - See Beyond frame finishes	---

Specification Example: ETO-AP-BY-VIZFMOUNT.M516908.SAL

Base Model	Description	Specification
ETO-AP-BY-VIZUMOUNT	Beyond Viz Floor/Ceiling U-Channel Mounting Brackets	ETO-AP-BY-VIZUMOUNT

Option	Specification Description	Specification
Custom Number	Custom Model Number	M516909
Trim Finish	Anodized, Clear	SAL
	Painted - See Beyond frame finishes	---

Specification Example: ETO-AP-BY-VIZUMOUNT.M516909.SAL

Base Model	Description	Specification
ETO-AP-BY-VIZCMOUNT	Beyond Viz Floor/Ceiling Two-Way "L" and Three-Way "T" Post Mounting Brackets	ETO-AP-BY-VIZCMOUNT

Option	Specification Description	Specification
Custom Number	Custom Model Number	M516913
Trim Finish	Anodized, Clear	SAL
	Painted - See Beyond frame finishes	---

Specification Example: ETO-AP-BY-VIZCMOUNT.M516913.SAL

Base Model	Description	Specification
ETO-AP-BY-VIZSPOST	Beyond Viz Access Post Inline	ETO-AP-BY-VIZSPOST

Option	Specification Description	Specification
Custom Number	Custom Model Number	M542557
Trim Finish	Anodized, Clear	SAL
	Painted - See Beyond frame finishes	---

Specification Example: ETO-AP-BY-VIZSPOST.M542557.SAL

Base Model	Description	Specification
ETO-AP-BY-VIZSSPOST	Beyond Viz Stacking Access Post Inline	ETO-AP-BY-VIZSSPOST

Option	Specification Description	Specification
Custom Number	Custom Model Number	M542561
Trim Finish	Anodized, Clear	SAL
	Painted - See Beyond frame finishes	---

Specification Example: ETO-AP-BY-VIZSSPOST.M542561.SAL

Base Model	Description	Specification
ETO-AP-BY-VIZNEND	Beyond Viz Narrow Finished End	ETO-AP-BY-VIZNEND

Option	Specification Description	Specification
Custom Number	Custom Model Number	M516910
Trim Finish	Anodized, Clear	SAL
	Painted - See Beyond frame finishes	---

Specification Example: ETO-AP-BY-VIZNEND.M516910.SAL

Base Model	Description	Specification
ETO-AP-BY-VIZSPLICE	Beyond Viz Post Splice Kit	ETO-AP-BY-VIZSPLICE

Option	Specification Description	Specification
Custom Number	Custom Model Number	M516911

Specification Example: ETO-AP-BY-VIZSPLICE.M516911

Base Model	Description	Specification
ETO-AP-BY-VIZSTRIM	Beyond Viz Stacking Post Trim	ETO-AP-BY-VIZSTRIM

Option	Specification Description	Specification
Custom Number	Custom Model Number	M516912
Trim Finish	Anodized, Clear	SAL
	Painted - See Beyond frame finishes	---

Specification Example: ETO-AP-BY-VIZSTRIM.M516912.SAL

Allsteel®

Allsteel Inc.
Muscatine, Iowa 52761

allsteeloffice.com

Form # A8766.A4 (5/24)