

Monolithic Panel Systems

Price & Specification Guide 2024

Prices effective February 1, 2024

PDF updated June 21, 2024

All content marked in red signifies an update to the previous version of this price guide published on February 1, 2024.

Limited Lifetime Warranty

Our unwavering commitment to our customers compels us to care, and our dedication to quality is just one of the ways we show our customers how much they mean to us.

We recognize that keeping up with the pace of change requires having products that work as hard as the people who use them. That's why each of our products is rigorously tested and certified to meet the highest industry standards.

In the unlikely event that any Allsteel product or component covered by the Allsteel Warranty should fail under normal workplace use because of defective material or workmanship, Allsteel promises to fix it. Because taking care of *people* is how Allsteel takes care of business.

For information on Allsteel's warranty coverage, visit AllsteelOffice.com.

Government Support – GovernmentSupport@hniworkplacefurnishings.com
Product, Parts, Non-Warranty Parts Orders – ProductSupport@hniworkplacefurnishings.com
Quick Ship Orders – QuickShip@hniworkplacefurnishings.com
Order Status – OrderStatus@hniworkplacefurnishings.com
General Inquiries – GeneralSupport@hniworkplacefurnishings.com

- Software support packages furnished to the customer, either by Allsteel® or by another source, which support the sale of Allsteel products are superseded by printed price lists.
- Prices are subject to change without notice. All orders are subject to prices in effect at the time of order.
- Please refer to your Allsteel Dealer Sales and Discount Policies for order placement information, terms and conditions.
- Additional copies of this Specification and Price List are available upon request from Allsteel Literature Fulfillment at 1-866-255-7833.

- Ordering information appears at the bottom of each product page complete with examples on how to specify. Fabric and finish pages are referenced at the bottom of product pages.

This publication is available as an interactive or downloadable PDF at www.allsteeloffice.com.

Questions or Comments?

Please call us at: **888-ALLSTEEL**
888-255-7833

Warranty	Inside Front Cover
Table of Contents	3
New, Revised, and Discontinued Products	4
COM and Specials Policies	5-7
Programs	9
Upholstery and Finishes	10-16
FIT™	
Finishes	18
Panel Fabrics	19
Laminate and Paint Matching	20
Overview of Components	21
Working with Panels	22
Specifying Fit Panels	23-25
Working with Gallery-to-Gallery Panels	26-27
Specifying Power & Electrical for Fit Panels	28
Working with Storage & Worksurface Connectors	29-31
Working with Fit Components	32-33
Fit 30", 35", 42", 50", 57½" Panels	34-38
Fit 30", 35", 42", 50", and 57½" for Use with Glass	39-43
Panel Systems Gallery Glass	44-46
Panel Connectors & Rails	47-48
Working with Accessories	49-50
Fit Panel Bench	51
Fit Accessories	52-53
Fit Countertops	54
Working with Electrical & Data	55-62
Electrical Components	63-65
OPTIMIZE™	
Finishes	68
Typicals Overview	69
Specifications	
Introduction and Overview	70-71
Working with Panels, Connectors, and Sliding Doors	72-75
Panels & Connectors	76-82
Electrical & Data	
Working with Electrical & Data	83-91
Electrical & Data Components	92-94
Worksurfaces & Supports	
Overview of Worksurfaces	95
Working with Worksurfaces and Supports	96-101
Working with Cadence® Freestanding Desking	102-110
Laminate Worksurfaces	111-117
9120 Worksurfaces	118-119
Worksurface Supports	120-122
Metal Overheads & Hutches	
Working with Overhead Storage	123-126
Overheads, Shelves, and Mounting Kits	127-128
Hutches, Tackboards, and Accessories	129
GALLERY PANELS	
Finishes	132
Panel Fabrics	133
Laminate and Paint Matching	134
Gallery-to-Gallery Panels	143
Freestanding Screens	144-145
Optimize Connector Kits	171
Panel Systems Gallery Glass	172-174
Accessories	175-177

CONCENSYS®	
Finishes	180
Specifications	
Introduction and Overview	181
Electrical (8-Wire)	
Working with Electrical & Data	182-188
Electrical & Data Components	189-192
Worksurfaces & Supports	
Working with Worksurfaces and Supports	193-200
Working with Cadence® Freestanding Desking	201-209
Laminate Worksurfaces	210-216
9120 Worksurfaces	217-218
Worksurface Supports	219-222
Metal Overheads	
Working with Overheads, Shelves, and Hutches	223-227
Overhead Cabinets, Shelves, and Tackboards	228-229
Hutches and Tackboards	230
ALIGN™	
Statement of Line	231
APPROACH™	
Statement of Line	232-235
INVOLVE®	
Statement of Line	236-237
ALTITUDE	
Paint Finishes, Laminates, Eased Edge	240
Fabrics	241
Working with Height-Adjustable Tables	242-247.2
Screens and Power Module	248
Altitude - Metal Screens	249-250
Power Rail Specifications	251-257
Working with Electrical and Data	258-262
HAT to Panel Brackets	263-264
Working with Organization Rail & Accessories & Screens	265
Altitude Height-Adjustable Tops, Bases, & Accessories	266-283
Altitude - A6	266-267
Worksurfaces for Height-Adjustable Bases	268-270
Cable Management	271-271.3
Power Rail - Electrical Components	272-274
A8 Screen Kits	275
Metal Screens and Tackboard Accessories	276-277
Power Rails and Accessories	278-281
HAT to Panel Brackets Pricing	282
Worksurface Mounted Rail and Accessories	283
EXTENSIONS™	
Introduction	284
Working with Ergonomic Accessories	285-286
Working with Organization Tools	287-292
Working with Illumination	293-296
Power/Data Modules and Wire Management	297-297.4
ACCESSORIES	
Working with Pivot Monitor Arms	298-301
APPENDIX AND INDEX	
Locking Specification/Easy Lock	302-304
Touch-Up Paint	305
Fabric Grades G-J and Upholstery Grades 9-23	306-307
Index — Model Numbers with Page Reference	308-312

Monolithic Panel Systems

New, Revised, and Discontinued Products

GSA/FEDERAL CONTRACT INFORMATION:

Model numbers identified with the following verbiage “When purchased separately without a configurable TAA compliant end product, not on GSA contract” is to mean that these configurable parts or components:

- Have no functionality or capability without being integrated into an end product; and
- Are considered Open Market if purchased without a configurable TAA compliant end product.

ITEMS ON GSA CONTRACT

Please note, in order to verify if an item is on GSA Contract or is “Open Market,” please use Compass quoting which is updated in real time with all GSA contract changes. If you need additional assistance, please contact your local sales representative.

NEW FINISHES

Studio Paints

- Ochre – P093
- Sienna – P092
- Cove – P096
- Harbor – P097
- Sage – P095
- Dune – P094

Stratawood Beigewood Maple SE878

Stratawood Field Elm Maple SE599

Stratawood Belair Maple SE934

Stratawood Florence Walnut ST579

Natural Florence Walnut NT579

Quarter Florence Walnut QT579

Belair LWBA

Field Elm laminate LWFE

NEW TEXTILES

Noble – Aegean, Amethyst, Aster, Blossom, Bluebell, Chamomile,

Conifer, Cottage, Darkness, Desert Sand, Dewfall, Dusted Sage, Flax, Harmony, Ice Caves, Icicle, Inky, Iris, Monarch, Pitch, Queen Bee, Sandcastle, Sedona, Sunbeam, Voyager, Windy Day.

Vast – Vineyard, Garden, Grasslands, Bay, Open Air, Atmosphere, Ocean,

Mountain Range, Highway, Tundra, Beach, Desert, Countryside

NEW EXTENSIONS

AJTRGH24

AJTRGH36

DE-EMPHASIZED FABRICS

Mica — 12/31/2024

DE-EMPHASIZED PRODUCTS

Wire Management Channel — AEV920 — 6/30/2024

Worksurface Wire Manager — Z5WM48, Z5WM54, Z5WM60, Z5WM66, Z5WM72, Z5WM78, Z5WM84 — 6/30/2024

COM Program

Allsteel understands that customers may at times want to specify fabrics outside of Allsteel's standard fabric offering. Our COM program was designed to make specifying COMs on Allsteel products a simpler, friendlier, and hassle-free process. This process is simple and easy to use, and is described below under "Allsteel to Supply (ATS)." If a Dealer wishes to manage the COM process themselves, they can do so by following guidelines under "Dealer to Supply (DTS)". **ATS is the preferred method for all COM fabrics.** With ATS, Company will provide acknowledgment based upon planned date of receipt of COM fabric and manage the entire process. DTS is allowed if it is not a partnership fabric or if Company does not have access to the supplier. **DTS may cause order delays and is strongly discouraged.** Find out more about Allsteel's COM process by emailing our COM Department at allsteelcomteam@allsteeloffice.com.

Allsteel to Supply (ATS):

1. Select the fabric you wish to use and check the COM Search on our [Website](http://AllsteelOffice.com) at: AllsteelOffice.com/Design Resources/Textiles & Finishes/COM Search or COM Search quick link. You will need to have the COM supplier's name, fabric pattern name, and color name to search for approved fabrics.
2. If your fabric is listed as an approved fabric, you may place your order directly with Allsteel Customer Support. Please use the fabric code (e.g., S216426XP) from the COM Test Request on your order in the place of the standard fabric code.

If your fabric is not listed as approved, you will need to select the "Request COM Test" link on the COM Search website. If your fabric is not listed as approved, and it is not a Partnership fabric you may request a "Dealer to Supply" code. Select the "Request COM Test" link on the COM Search website. Your name, company name and email will be prepopulated fields. The secondary email, project name, and bid/contract number are optional information. The supplier, pattern, and color will show a list by clicking in the box and entering the first letter of the name and these are free form text boxes. Once that information is entered click add. (Multiple series can be added to the same request if they are the same supplier, pattern, and color.) Then click submit.
3. An email will be sent to the to the requestor stating the COM Request was successfully submitted. Up to four emails could be received: Testing materials requested, in testing, and final approval/denial with price grade and fabric code. It's rare actual test yardage is required. Testing is mainly done by reviewing the attributes of the fabric. The testing process takes approximately 48 hours. Written COM price quotes hold pricing for 90 days after issue date.
4. Once the fabric has been approved by Allsteel, enter your order directly with Allsteel Customer Support. Allsteel will purchase all COM fabric directly from the COM suppliers and schedule for production.

In the event that the Dealer decides to cancel a COM fabric order, the Dealer is responsible for the cost of the fabric plus a handling charge that is equal to 10% of the fabric cost.

Dealer to Supply (DTS):

1. Select the fabric you wish to use and check the COM Search on our [Website](http://AllsteelOffice.com) at: AllsteelOffice.com/Design Resources/Textiles & Finishes/COM Search or COM Search quick link. Or call Allsteel Customer Support to see if the fabric you have chosen has already been tested and approved on the product you are interested in.

You will need to have the COM supplier's name, fabric pattern name, and color name for this inquiry.

2. If your fabric is not listed as approved, and it is not a Partnership fabric you may request a "Dealer to Supply" code. Select the "Request COM Test" link on the COM Search website. Your name, company name and email will be prepopulated fields. The secondary email, project name, and bid/contract number are optional information. The supplier, pattern, and color will show a list by clicking in the box and entering the first letter of the name and these are free form text boxes. Once that information is entered click add. (Multiple series can be added to the same request if they are the same supplier, pattern, and color.) Then click submit.
3. An email will be sent to the to the requestor stating the COM Request was successfully submitted. Up to four emails could be received: Testing materials requested, in testing, and final approval/denial with price grade and fabric code. It's rare actual test yardage is required. Testing is mainly done by reviewing the attributes of the fabric. The testing process takes approximately 48 hours.
4. Make sure to use a "Dealer to Supply" COM code (e.g., S216426ZP) and place your order directly with Allsteel Customer Support.
5. All "Dealer to Supply" orders will be charged Grade 4 pricing for seating, Grade 3 for Gather, and Grade D pricing for panels. Dealers will pay for the COM fabric separately.
6. All "Dealer to Supply" fabric must be sent on a fabric roll. Estimate the yardage required by using the yardage requirements listed in the price list by model. For questions please contact Allsteel Customer Support.
7. Place your fabric order directly with the COM Supplier with instructions for the fabric to be sent on a fabric roll to:

HNI Textile Distribution Center

COM Production Yardage — PO Number

Docks 20-22
301 Mulberry Avenue
Muscatine, IA 52761

Information that **MUST** be included in the packing slip attached to the DTS fabric:

1. Dealer's Purchase Order number to Allsteel
2. Allsteel's Tracking number for the COM fabric
3. Dealer Name
4. Yards of Fabric

If the fabric shipment does not match the correct fabric and yardage, Allsteel will notify the Dealer for resolution.

If Allsteel receives fabric with incorrect labeling or fabric yardage that cannot be linked to an Allsteel furniture order, Allsteel will hold the fabric for up to 4 weeks. After 4 weeks Allsteel will dispose of the fabric. There are no exceptions to this policy.

Specific to DTS orders - The customer should send only the amount needed for the order. Excess yardage, or yardage not attached to an order will be disposed of at Allsteel's discretion.

Any canceled orders are subject to cancellation charges up to the full value of the Allsteel product canceled. Allsteel will determine the actual cancellation charge at the time the cancellation is requested.

8. For additional details on "Dealer to Supply" fabric refer to your Allsteel terms and conditions.

Additional Policy Information:

The company assumes no responsibility for the overall appearance, flammability, normal durability, colorfastness, or any other quality standards. The company reserves the right to reject a COM if the quality of the COM is not satisfactory for the product. Should this occur, the customer will be notified with an explanation when the issue is found.

The company is not responsible for fabric that has become obsolete at the COM supplier, that is of poor quality, or that is delivered late to the manufacturer from the COM supplier.

All cancellations or changes to COM orders are subject to Company approval. Because of the nature of COM, special fabrics, finishes, and structural modifications, products ordered as specials and then canceled prior to shipment are subject to cancellation costs up to the full value of the product canceled. The company determines the actual cancellation charge at the time the cancellation is requested. Upon approval, a cancellation number is issued to the Customer.

Purchase orders will not be accepted or entered unless the testing process is complete with positive results.

If all testing has been previously completed, re-testing is only necessary if fabric is to be used on a different product, or pattern direction has changed from that previously approved.

Previous test results can be obtained by a customer on the COM Search on [our Website](#) or by calling Allsteel Customer Support.

All COM fabric will be applied to seating and panel systems Pattern Cut unless Railroad Cut is requested and approved on the COM Test Request. Any fabrics approved as a width pass, the dealer is responsible for clarifying Railroad Cut on orders containing items that are too large to support the Pattern Cut of a fabric application (any items larger than 48" high or wide).

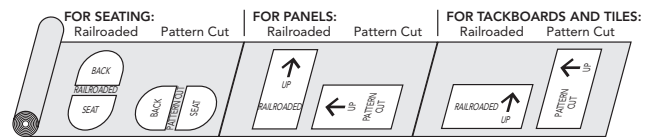

Fire Retardant

The Dealer is responsible for ensuring that the COM fabric is certified to meet all flame retardant requirements.

For more information, please contact Allsteel Customer Support.

YARDAGE REQUIREMENTS FOR FABRIC WITH REPEATS — FOR USE ON GATHER™ PRODUCTS

Fabric Width	Plain Fabric	2"– 14" Repeat	15"– 19" Repeat	20"– 27" Repeat	28"– 36" Repeat
54"	0	+15%	+20%	+25%	+30%
53"	+6%	+19%	+24%	+28%	+36%
52"	+13%	+23%	+28%	+33%	+38%
51"	+19%	+26%	+31%	+36%	+41%
50"	+25%	+30%	+35%	+40%	+45%
49"	+30%	+35%	+40%	+45%	+50%
48"	+35%	+40%	+45%	+50%	+55%
47"	+45%	+50%	+55%	+58%	+65%

Depending upon the pattern repeat, it may be necessary to pattern cut the fabric. This will require 10% additional fabric.

To calculate multiple repeats (vertical and horizontal), add each repeat for total yardage required. For example for a fabric width of 54": 7" vertical requires 15%, 15" horizontal requires 20% total additional yardage required equals 35% (15% + 20%). Therefore, if your chair requires 2 yards of fabric, multiply 2 by 35%. Then 2.7 yards will be yardage required.

Special Paint & Stain Policy

Allsteel at its own discretion may modify its standard products with non-standard paint and stain colors to meet specific needs. Dealer is required to submit a special paint or stain request via the COM Search on [our Website](#). A sample of the non-standard paint or stain color desired will be required for matching. Pricing, lead time, and order information will be provided at the time of approval.

- For each new requested stain or paint, there will be a \$500 net fee to cover supplier costs to match the special item.
- For existing, previously-approved stains or paints, there is no \$500 matching fee, however, there is a sample chip fee of \$175 net for stains and \$100 net for paints.
- Samples, preferably at least 3" x 5" chips, of the exact color desired should be sent to the Allsteel Tailored Products Group. Paint matches require (3) sample chips and stain matches require (3) sample chips. Please mail these sample chips to the address below and reference the Special Item Request Number from Tailored Solutions.

Allsteel Inc.

Attn: COM Team
200 Oak St.
Muscatine, IA 52761

- Allsteel will color match the sample and send control samples to the address provided in the request. Dealer will review Allsteel's color match and approve by signing the back of the sample chip. Send the signed sample back to the Allsteel Tailored Products Group.
- Special paints will be assigned a paint price grade.
- Orders will not be accepted until Allsteel receives the Dealer's written approval on the color match.
- Extended lead times will apply on orders containing special paints or stains.
- Due to manufacturing techniques, materials, and quality issues, some exclusions will apply and some matches may be declined.

Important Notes

- Natural veneer is subject to nature's quality control. Differences in grain and color are naturally occurring variations and cannot be controlled by the manufacturer and cannot be considered as product defects. Natural veneer has the characteristics and beauty of a living organism; with its own variations of grain, growth, and color patterns. For these reasons, Natural veneer is preferred by many for its warmth and personal characteristics.
- Color changes will occur over time when wood is exposed to light. For this reason, when new product is ordered as an addition to existing product, there will be color variances between the old and new product. Please remember when specifying new product that although the species of veneer will be the same, additional product is being manufactured from a different tree. It may take several months for the new furniture to mature to the color level of existing product. Even with this maturation process the additional product will not be an exact match.

Special Laminate Policy

The Company at its own discretion may modify its standard products with non-standard laminates to meet specific needs. Contact the Allsteel Tailored Products Group for pre-approved Wilsonart, Formica, Nevamar and Pionite laminates and pricing for special laminates. When requesting a special laminate please supply manufacturer, along with name and pattern number of laminate.

- Extended lead times will apply on orders containing special laminates.
- Due to manufacturing techniques, materials, and quality issues, some product exclusions will apply and some requests may be declined.

Monolithic Panel Systems

Open Line Laminate Program

[GSA Reference Page](#)

Allsteel Open Line Laminate Program

The Open Line Laminate (OLL) program makes it even easier for a customer to tailor their Allsteel product for a custom look. Select Allsteel furniture products accommodate hundreds of graded-in high-pressure laminates (HPL) from the leading laminate manufacturers' open lines.

Laminates that are currently available in the program can be viewed in specification tools.

Requests to add laminates to the standard specials program can be submitted through the CET Specials Integration tool as well as Community.

Matching edge options are not available offered for laminates in the OLL program. When selecting a laminate please select an edge option from the Allsteel standard offering. If a matching edge is required a modification request can be submitted through the CET Specials Integration tool as well as Community.

Due to manufacturing techniques, materials, quality issues of varying laminates, and minimum order quantities some product exclusions will apply, and some requests may be declined.

Extended lead times may apply on orders containing special laminates.

Contact the Tailored Products Group for questions or additional information regarding pre-approved laminates and pricing.

Allsteel

Phone: 888-255-7833 Option 4.2

Email: ASITPG@allsteeloffice.com

For edge band recommendations from the Allsteel standard offering, please email the HNI Workplace Colors, Materials and Finishes team at allsteel finishes@allsteeloffice.com.

Allsteel edge samples can be ordered through the Allsteel literature [Website](https://www.AllsteelOffice.com), <https://www.AllsteelOffice.com>.

For laminate samples, please contact the manufacturer directly:

Wilsonart

<https://www.wilsonart.com/>

1-800-433-3222

Formica

<https://www.formica.com/en-us/>

1-800-FORMICA (367-6422)

Nevamar and Pionite

<https://www.panolam.com>

877-726-6526

Everyday Advantage[®]

New terms and conditions for EDA:

1. Orders must clearly state “Everyday Advantage Order” and include the appropriate Everyday Advantage contract number:
 - Everyday Advantage Std-0125, Everyday Advantage Canada-0127
2. Everyday Advantage orders are not eligible for bid pricing.
3. Program discounting includes the complete Optimize, Further, and Terrace systems lines, private office solution, Approach and Involve storage. This program also includes Acuity, Access, Evo, Inspire, Lyric, Mimeo, Nimble, Quip, Relate, Seek, and Svelte, seating. Altitude, Aware, and Structure tables are also available, along with Align pedestals, lockers and metal storage and Essentials pedestals, and Radii storage lines. In addition, Extensions ergonomic accessories and lighting are part of the standard offering. All other product not called out is available for order on the contract but will receive standard discounting of 55%–65%.
4. All textiles and finishes except for veneer and some wood finishes are available, depending on quantity and selection, and may have extended lead times.
5. Everyday Advantage orders are not limited to a minimum or maximum.
6. All orders ship based on standard lead times. Large-quantity orders of like products may be subject to longer lead times.
7. Standard freight terms apply.
8. If driver assistance is needed, standard driver assist charges will be added at time of order entry.

Allsteel Inc. reserves the right to amend or terminate this program at anytime with 30 days written notice. Allsteel is not liable for service delays caused by force majeure (circumstances beyond Allsteel's control).

GRADE A

*APPOINT PANEL

Artichoke.....	APN911
Blackberry.....	APN932
Bronze.....	APN922
Carbon.....	APN928
Chai.....	APN912
Cherry.....	APN930
Dark Pewter.....	APN917
Dune.....	APN915
Espresso.....	APN923
Framboise.....	APN931
Frost.....	APN934
Jet.....	APN927
Lawn.....	APN925
Mandarin.....	APN929
Morel.....	APN909
Nimbus.....	APN916
Platinum.....	APN924
Turquoise.....	APN926

BINARY †

Blush.....	BNRY12
Coal.....	BNRY06
Cream.....	BNRY01
Denim.....	BNRY08
Diamond.....	BNRY03
Graphite.....	BNRY05
Juniper.....	BNRY10
Lagoon.....	BNRY07
Lavendar.....	BNRY11
Mineral.....	BNRY04
Reef.....	BNRY09
Sand Dollar.....	BNRY02

*CENTURION^w

Apricot.....	CU47
Bark.....	CU25
Black.....	CU10
Espresso.....	CU49
Fog.....	CU03
Frost.....	CU22
Goldenrod.....	CU27
Indigo.....	CU06
Iris.....	CU50
Iron Ore.....	CU19
Jade.....	CU83
Marsala.....	CU63
Morel.....	CU24
Navy.....	CU98
Peacock.....	CU97
Pear.....	CU84
Ruby.....	CU67
Sapphire.....	CU09

CIRCUIT † ♣

Atlas.....	CIRC35
Dolphin.....	CIRC63
Island White.....	CIRC14
Moon.....	CIRC07
Night.....	CIRC49
Pacific.....	CIRC28
Quartz.....	CIRC01
Sienna.....	CIRC56
Silk.....	CIRC21
Snap Pea.....	CIRC42

ETCH*

Axis.....	ECH913
Blend.....	ECH914
Cast.....	ECH912
Highlight.....	ECH910
Midtone.....	ECH911
Outline.....	ECH908
Shade.....	ECH909
Tonal.....	ECH916
Vanish.....	ECH915

GRADE A – continued

*LANDSCAPE

Corn silk.....	LN15
Drift.....	LN05
Khaki.....	LN20
Sheen.....	LN10
Slate.....	LN35
Umber.....	LN25
Urban.....	LN30

*LUCY

Aspen.....	LC932
Corn silk.....	LC930
Dusk.....	LC922
Fawn.....	LC933
Graphite.....	LC934
Mist.....	LC920
Neutra.....	LC924
Pewter.....	LC935
Snowdrop.....	LC928

NOBLE

Aegean.....	NBLE18
Amethyst.....	NBLE19
Aspen.....	NBLE14
Aster.....	NBLE20
Blossom.....	NBLE21
Bluebell.....	NBLE22
Bordeaux.....	NBLE01
Brick.....	NBLE02
Chambray.....	NBLE10
Chamomile.....	NBLE23
Clementine.....	NBLE04
Conifer.....	NBLE24
Cottage.....	NBLE25
Darkness.....	NBLE26
Dawn.....	NBLE13
Desert Sand.....	NBLE27
Dewfall.....	NBLE28
Dusted Sage.....	NBLE29
Flax.....	NBLE30
Grass.....	NBLE07
Gunmetal.....	NBLE15
Harmony.....	NBLE31
Harvest.....	NBLE12
Ice Caves.....	NBLE32
Icicle.....	NBLE33
Inky.....	NBLE34
Iris.....	NBLE35
Jade.....	NBLE06
Knight.....	NBLE17
Mesa.....	NBLE03
Monarch.....	NBLE36
Pacific.....	NBLE08
Pitch.....	NBLE37
Queen Bee.....	NBLE38
Rainforest.....	NBLE05
Regal.....	NBLE11
Sandcastle.....	NBLE39
Sedona.....	NBLE40
Stormy.....	NBLE16
Sunbeam.....	NBLE41
Voyager.....	NBLE42
Windy Day.....	NBLE43

GRADE B

COAST † ♣

Channel.....	COA914
Dune.....	COA903
Headlands.....	COA910
Marsh.....	COA902
Pebble.....	COA912
Pier.....	COA913
Shoal.....	COA901
Silt.....	COA906
Tide.....	COA908

DISPERSE †

Autumn.....	DISP03
Branch.....	DISP10
Coffee Bean.....	DISP13
Dusk.....	DISP09
Emerald City.....	DISP08
Gold Rush.....	DISP02
Igloo.....	DISP11
Ink.....	DISP06
Mist.....	DISP12
Oatmeal.....	DISP15
Prince.....	DISP07
Reservoir.....	DISP01
Rose.....	DISP04
Spring.....	DISP05
Steel.....	DISP16
Taupe.....	DISP14

*MICA (De-emphasized)

Anthracite.....	MCA911
Breeze.....	MCA918
Bronze.....	MCA913
Buff.....	MCA914
Cremini.....	MCA917
Crystal †.....	MCAWIT
Dew.....	MCA920
Dove.....	MCA912
Fresh.....	MCA916
Mineral.....	MCA915
Nectar.....	MCA919
Shale.....	MCA910

GRADE A – continued

*REFUGE

Artesian.....	RFG996
Dune.....	RFG992
Eclipse.....	RFG990
Frost †.....	RFG993
Glacier †.....	RFG991
Mineral.....	RFG998
Tidal.....	RFG994

TEMPEST

Dragonfly.....	TP930
Frost.....	TP915
Full Stream.....	TP980
Gold Rush.....	TP910
Slate.....	TP945
Tumbleweed.....	TP970
Wind Chill.....	TP940
Zebra.....	TP935

VAST

Vineyard.....	VST01
Garden.....	VST02
Grasslands.....	VST03
Bay.....	VST04
Open Air.....	VST05
Atmosphere.....	VST06
Ocean.....	VST07
Mountain Range.....	VST08
Highway.....	VST09
Tundra.....	VST10
Beach.....	VST11
Desert.....	VST12
Country Side.....	VST13

GRADE B

COAST † ♣

Channel.....	COA914
Dune.....	COA903
Headlands.....	COA910
Marsh.....	COA902
Pebble.....	COA912
Pier.....	COA913
Shoal.....	COA901
Silt.....	COA906
Tide.....	COA908

DISPERSE †

Autumn.....	DISP03
Branch.....	DISP10
Coffee Bean.....	DISP13
Dusk.....	DISP09
Emerald City.....	DISP08
Gold Rush.....	DISP02
Igloo.....	DISP11
Ink.....	DISP06
Mist.....	DISP12
Oatmeal.....	DISP15
Prince.....	DISP07
Reservoir.....	DISP01
Rose.....	DISP04
Spring.....	DISP05
Steel.....	DISP16
Taupe.....	DISP14

*MICA (De-emphasized)

Anthracite.....	MCA911
Breeze.....	MCA918
Bronze.....	MCA913
Buff.....	MCA914
Cremini.....	MCA917
Crystal †.....	MCAWIT
Dew.....	MCA920
Dove.....	MCA912
Fresh.....	MCA916
Mineral.....	MCA915
Nectar.....	MCA919
Shale.....	MCA910

GRADE B – continued

*SPIN PANEL

Alabaster.....	SPIN02
Cavern.....	SPIN03
Cobblestone.....	SPIN04
Ember.....	SPIN06
Flame.....	SPIN07
Heron.....	SPIN13
Oat.....	SPIN01
Ocean.....	SPIN12
Plum.....	SPIN15
Pool.....	SPIN11
Raven.....	SPIN10
Rhubarb.....	SPIN14
Tropic.....	SPIN08
Willow.....	SPIN05

*TERRAIN

Bay.....	TRRN05
Bayou.....	TRRN35
Canyon.....	TRRN30
Cliff.....	TRRN45
Crest.....	TRRN25
Delta.....	TRRN10
Plateau.....	TRRN15
Ridge.....	TRRN20
Valley.....	TRRN40

ALLSTEEL PARTNERSHIP PROGRAM

Allsteel understands that customers may want to specify panel and seating textiles outside of Allsteel's standard offering. Allsteel's **Partnership Program** consists of on-trend and design-forward patterns that have been tested and approved by Allsteel for use on Allsteel products. A subset of these approved patterns is available on cards in the textile binder, while numerous others are available on our website, allsteeloffice.com.

For memo samples, please contact our partners:

- Camira, memos@camirafabrics.com
1.616.288.0655
- CF Stinson, cfstinson.com
1.800.841.6279
- HBF Textiles, hbftextiles.com
1.877.494.5727
- Maharam, maharam.com
1.800.645.3943

The intent of the **Partnership Program** is to offer a wide variety of on-trend textiles to meet your varied needs, but since these textiles are not part of our standard offering they may be subject to extended lead times. Because new materials will be introduced regularly, Allsteel reserves the right to change the offering at any time.

^w Limited to products 48"W or less.

† Panel fabric is not available on Concensys®.

♣ Panel fabric is not available on Involve®.

▼ Panel fabric is not available on Further™.

♠ Panel fabric is not available on Optimize®.

* Not available on 72"W.

Multi-use fabrics are seating fabrics that can be used on specific Allsteel panels systems, providing more color and pattern options. The applicable Allsteel multi-use fabrics are noted with System designators in the Seating, Collaboration & Tables Price List. Refer to website for graded in partnership fabrics for vertical applications.

Notes

UPHOLSTERY

Finishes

FINISHES

Paint Name	Paint Code	Grade	Touch Ups	Pivot Monitor Arms	Pivot GSA Monitor Arms	Concensys	Optimize	Extensions	Metal Center Drawers	Power Pole	Cable Management Tray	Altitude A6 Table Bases	Altitude A8 Table Bases and Utility Bay
Black	P27	1	•			•	•	•	•	•			
Black	P71	1	•								•	•	
Black	BLK	1		•									
Brownstone	P7D	1	•			•	•	•	•	•			
Bungalow	P7C	1	•			•	•	•	•	•			
Carbon	P4Q	1	•										
Charblack	CBK	1	•								•		
Charblack Metallic*	P80	1	•										
Cinder	P7Q	1	•				•	•	•		•		
Designer White	WHT	1											
Designer White	PJW	1	•			•	•	•	•	•			•
Flint	P02	1	•			•	•	•	•	•			
Fog	FOG	1											
Fossil	P28	1	•			•	•	•	•		•		
Loft	P7B	1	•			•	•	•	•	•			
Muslin	P4J	1	•			•	•	•	•	•			
Nickel	P8L	1										•	
Parchment	P93	1	•			•	•	•	•		•		
Pebble	P8R	1	•				•	•	•		•		
Pewter	P8D	1	•				•	•	•		•		
Platinum Metallic Texture	P6H	1											
Putty	PJS	1											
Salt	P8C	1	•				•	•	•		•		
Shadow	P4K	1											
Textured Brownstone	P7J	1	•										
Textured Designer White	PK7	1	•										
Textured Flint	P7A	1	•										
Textured Loft	P7L	1	•										
Textured Muslin	P7M	1	•										
Textured Pebble	P8Y	1	•										
Textured Salt	P8Z	1	•										
Textured Titanium	P8V	1	•										
Titanium	P8T / T	1	•				•	•	•		•		
White	PD8	1										•	
Anodized Silver	PR0	2	•										
Champagne Metallic	PR5	2	•			•	•	•	•		•		
Designer White High Gloss 65	P8W	2	•										
Graphite Metallic Texture	P85	2	•										
Gunmetal Metallic	PR3	2	•			•	•	•	•		•		
Matte Gold	P8G	2											
Night Bronze	P8B	2	•					•					
Platinum Metallic	PR2	2	•			•	•	•	•		•		
Pyrite	PJE	2	•					•					
Silver	PR6	2	•				•	•			•		•
Silver Generic	SVR	2		•	•								
Silver Texture	PR8	2	•										
Solar Black	P8X	2	•				•	•					
Atom	P8S	3	•				•	•					
Blossom	P8K	3	•				•	•					
Bullseye	PJF	3	•				•	•					
Ember	P8P	3	•				•	•					
Ion	P8N	3	•				•	•					
Iris	P8J	3	•				•	•					
Krypton	P8F	3	•				•	•					
Regatta	P8M	3	•				•	•					
Markerboard White	MKP	6											

Finishes

Paint Name	Paint Code	Grade	Altitude A8 Grommets and Power Rails	Altitude Metal Screens	Gallery Panels Connectors	Hands Free Pulls	Universal Screens
Black	P27	1					
Black	P71	1	•	•	•		•
Black	BLK	1					
Brownstone	P7D	1	•	•	•		•
Bungalow	P7C	1	•	•	•		
Carbon	P4Q	1					
Charblack	CBK	1					
Charblack Metallic*	P80	1					
Cinder	P7Q	1	•	•	•		•
Designer White	WHT	1					
Designer White	PJW	1	•	•	•		•
Flint	P02	1	•	•	•		•
Fog	FOG	1					
Fossil	P28	1	•	•	•		•
Loft	P7B	1	•	•	•		•
Muslin	P4J	1	•	•	•		•
Nickel	P8L	1					
Parchment	P93	1			•		
Pebble	P8R	1	•	•	•		•
Pewter	P8D	1	•	•	•		•
Platinum Metallic Texture	P6H	1					
Putty	PJS	1					
Salt	P8C	1	•	•	•		•
Shadow	P4K	1					
Textured Brownstone	P7J	1					
Textured Designer White	PK7	1					
Textured Flint	P7A	1					
Textured Loft	P7L	1					
Textured Muslin	P7M	1					
Textured Pebble	P8Y	1					
Textured Salt	P8Z	1					
Textured Titanium	P8V	1				•	
Titanium	P8T / T	1	•	•	•		•
White	PD8	1					
Anodized Silver	PR0	2					
Champagne Metallic	PR5	2	•	•	•		•
Designer White High Gloss 65	P8W	2					
Graphite Metallic Texture	P85	2					
Gunmetal Metallic	PR3	2			•		•
Matte Gold	P8G	2					
Night Bronze	P8B	2	•	•	•		
Platinum Metallic	PR2	2			•		
Pyrite	PJE	2	•	•	•		
Silver	PR6	2	•	•	•		•
Silver Generic	SVR	2					
Silver Texture	PR8	2					
Solar Black	P8X	2	•	•	•		•
Atom	P8S	3	•	•	•		•
Blossom	P8K	3	•	•	•		•
Bullseye	PJF	3	•	•	•		•
Ember	P8P	3	•	•	•		•
Ion	P8N	3	•	•	•		•
Iris	P8J	3	•	•	•		•
Krypton	P8F	3	•	•	•		•
Regatta	P8M	3	•	•	•		•
Markerboard White	MKP	6		•			•

Finishes

FINISHES

Pattern Name	Code	Grade	Altitude	System Laminate Doors	Systems Worksurfaces
Ash	LT3B	1	•	•	•
Handspun Pearl	LAHP	1	•	•	•
Handspun Dove	LAHD	1	•	•	•
Handspun Slate	LAHS	1	•	•	•
Handspun Chestnut	LAHC	1	•	•	•
Silver Mesh	LT8D	1	•	•	•
Black	P	1	•	•	•
Brownstone	LM13	1	•	•	•
Bungalow	LM12	1	•	•	•
Designer White 15051	LDW1	1	•	•	•
Flint	LM16	1	•	•	•
Fossil Shale	LEH1	1	•	•	•
Loft	LM11	1	•	•	•
Muslin	LM15	1	•	•	•
Titanium	LT11	1	•	•	•
Belair	LWBA	1	•	•	•
Bourbon Cherry	H	1	•	•	•
Field Elm	LWFE	1	•	•	•
Florence Walnut	LFW1	1	•	•	•
Kingswood Walnut	LK11	1	•	•	•
Natural Maple	LWD	1	•	•	•
NeoWalnut	LNU1	1	•	•	•
Pinnacle	PINC	1	•	•	•
Shaker Cherry	LW7C	1	•	•	•
Beigewood	LWBE	2	•	•	•
Fawn Cypress	LFC1	2	•	•	•
Lowell Ash	LLA1	2	•	•	•
Mangalore Mango	LMM1	2	•	•	•
Natural Recon	LNR1	2	•	•	•
Phantom Charcoal	LPC1	2	•	•	•
Phantom Ecu	LPE1	2	•	•	•
Portico Teak	LPT1	2	•	•	•
Skyline Walnut	LSW1	2	•	•	•
Veranda Teak	LVT1	2	•	•	•
Natural Walnut	LWNW	3	•	•	•
Open Line Laminate Program	N/A	Varies	•	•	•

Finishes

System Worksurfaces

Veneer Type	Stain Name	Code	Grade	
FSC Stratawood Cherry	Cinnamon Cherry	FSCSC260	2	•
FSC Stratawood Cherry	Lowell Ash	FSCSC394	2	•
FSC Stratawood Cherry	Clear Cherry	FSCSC700	2	•
FSC Stratawood Cherry	Light Cherry	FSCSC701	2	•
FSC Stratawood Cherry	Shaker Cherry	FSCSC774	2	•
FSC Stratawood Cherry	Burnished Cherry	FSCSC777	2	•
FSC Stratawood Maple	Field Elm	FSCSE599	2	•
FSC Stratawood Maple	Clear Maple	FSCSE800	2	•
FSC Stratawood Maple	Harvest Maple	FSCSE856	2	•
FSC Stratawood Maple	Beigewood	FSCSE878	2	•
FSC Stratawood Maple	Phantom Ecu	FSCSE912	2	•
FSC Stratawood Maple	Belair	FSCSE934	2	•
FSC Stratawood Rift Oak	Clear Oak	FSCSF300	2	•
FSC Stratawood Rift Oak	Dark Rift Oak	FSCSF331	2	•
FSC Stratawood Walnut	Florence Walnut	FSCST579	2	•
FSC Stratawood Walnut	Light Walnut	FSCST601	2	•
FSC Stratawood Walnut	Skyline Walnut	FSCST625	2	•
FSC Stratawood Walnut	Pinnacle Walnut	FSCST679	2	•
FSC Stratawood Walnut	Sumatra Walnut	FSCST693	2	•
FSC Natural Cherry	Cinnamon Cherry	FSCNC260	2	•
FSC Natural Cherry	Lowell Ash	FSCNC394	2	•
FSC Natural Cherry	Medium Red Cherry	FSCNC512	2	•
FSC Natural Cherry	Clear Cherry	FSCNC700	2	•
FSC Natural Cherry	Light Cherry	FSCNC701	2	•
FSC Natural Cherry	Shaker Cherry	FSCNC774	2	•
FSC Natural Cherry	Burnished Cherry	FSCNC777	2	•
FSC Natural Maple	Natural Maple-Clear	FSCNE800	2	•
FSC Natural Maple	Harvest Maple	FSCNE856	2	•
FSC Natural Walnut	Ebony Walnut	FSCNT509	2	•
FSC Natural Walnut	Florence Walnut	FSCNT579	2	•
FSC Natural Walnut	Light Walnut	FSCNT601	2	•
FSC Natural Walnut	Skyline Walnut	FSCNT625	2	•
FSC Natural Walnut	Nutmeg Walnut	FSCNT629	2	•
FSC Natural Walnut	Pinnacle Walnut	FSCNT679	2	•
FSC Natural Walnut	Sumatra Walnut	FSCNT693	2	•
FSC Natural Rift Cut Oak	Fawn Cypress	FSCRF108	3	•
FSC Natural Rift Cut Oak	Light Rift Oak	FSCRF301	3	•
FSC Natural Rift Cut Oak	Dark Rift Oak	FSCRF331	3	•
FSC Natural Rift Oak	Phantom Ecu	FSCRF912	3	•
Natural Cherry	Cinnamon Cherry	NC260	2	•
Natural Cherry	Lowell Cherry	NC394	2	•
Natural Cherry	Medium Red Cherry	NC512	2	•
Natural Cherry	Light Cherry	NC701	2	•
Natural Cherry	Shaker Cherry	NC774	2	•
Natural Cherry	Burnished Cherry	NC777	2	•
Natural Maple	Natural Maple-Clear	NE800	2	•
Natural Maple	Harvest Maple	NE856	2	•
Natural Rift Cut Oak	Fawn Cypress	RF108	3	•
Natural Rift Cut Oak	Light Rift Oak	RF301	3	•
Natural Rift Cut Oak	Dark Rift Oak	RF331	3	•
Natural Rift Cut Oak	Natural Recon	RF896	3	•
Natural Rift Cut Oak	Phantom Ecu	RF912	3	•
Natural Walnut	Ebony Walnut	NT509	2	•
Natural Walnut	Florence Walnut	NT579	2	•
Natural Walnut	Light Walnut	NT601	2	•
Natural Walnut	Skyline Walnut	NT625	2	•
Natural Walnut	Nutmeg Walnut	NT629	2	•
Natural Walnut	Pinnacle Walnut	NT679	2	•
Natural Walnut	Sumatra Walnut	NT693	2	•

FINISHES

Finishes

System Worksurfaces

Veneer Type	Stain Name	Code	Grade	
Stratawood Cherry	Cinnamon Cherry	SC260	2	•
Stratawood Cherry	Lowell Ash	SC394	2	•
Stratawood Cherry	Clear Cherry	SC700	2	•
Stratawood Cherry	Light Cherry	SC701	2	•
Stratawood Cherry	Shaker Cherry	SC774	2	•
Stratawood Cherry	Burnished Cherry	SC777	2	•
Stratawood Maple	Field Elm	SE599	2	•
Stratawood Maple	Clear Maple	SE800	2	•
Stratawood Maple	Harvest Maple	SE856	2	•
Stratawood Maple	Beigewood	SE878	2	•
Stratawood Maple	Phantom Ecrú	SE912	2	•
Stratawood Maple	Belair	SE934	2	•
Stratawood Silver Oak	Clear	SB100	2	•
Stratawood Silver Oak	Portico Teak	SB150	2	•
Stratawood Rift Oak	Clear Oak	SF300	2	•
Stratawood Rift Oak	Dark Rift Oak	SF331	2	•
Stratawood Walnut	Florence Walnut	ST579	2	•
Stratawood Walnut	Light Walnut	ST601	2	•
Stratawood Walnut	Skyline Walnut	ST625	2	•
Stratawood Walnut	Pinnacle Walnut	ST679	2	•
Stratawood Walnut	Sumatra Walnut	ST693	2	•

FINISHES

- Finishes 18
- Panel Fabrics 19
- Laminate and Paint Matching 20
- Overview of Components 21
- Working with Panels 22
- Specifying Fit Panels..... 23-25
- Working with Gallery-to-Gallery Panels 26-27
- Specifying Power & Electrical for Fit Panels 28
- Working with Storage & Worksurface Connectors 29-31
- Working with Fit Components..... 32-33
- Fit 30", 35", 42", 50", 57½" Panels 34-38
- Fit 30", 35", 42", 50", and 57½" for Use with Glass 39-43
- Panel Systems Gallery Glass 44-46
- Panel Connectors & Rails 47-48
- Working with Accessories 49-50
- Fit Panel Bench..... 51
- Fit Accessories 52-53
- Fit Countertops 54
- Working with Electrical & Data. 55-62
- Electrical Components 63-65



PAINT FINISHES

GRADE P1

Black.....	P71
Brownstone.....	P7D
Bungalow.....	P7C
Cinder.....	P7Q
Cove.....	P096
Designer White.....	PJW
Dune.....	P094
Flint.....	P02
Fossil.....	P28
Harbor.....	P097
Loft.....	P7B
Muslin.....	P4J
Parchment.....	P93
Pebble.....	P8R
Pewter.....	P8D
Sage.....	P095
Salt.....	P8C
Textured Brownstone.....	P7J
Textured Designer White.....	PK7
Textured Flint.....	P7A
Textured Loft.....	P7L
Textured Muslin.....	P7M
Textured Pebble.....	P8Y
Textured Salt.....	P8Z
Textured Titanium.....	P8V
Titanium.....	P8T

GRADE P2

Champagne Metallic.....	PR5
Gunmetal Metallic.....	PR3
Matte Gold.....	P8G
Night Bronze.....	P8B
Platinum Metallic.....	PR2
Pyrite.....	PJE
Silver.....	PR6
Silver Texture.....	PR8
Solar Black.....	P8X

Metallic paints, due to varying reflectance, may appear to have less visual color consistency than other paint finishes, even when L/A/B values are exactly the same. (L/A/B — measurable aspects of color — values are maintained within a specified range, to ensure consistent appearance of paint colors.)

GRADE P3

Atom.....	P8S
Blossom***.....	P8K
Bullseye.....	PJF
Ember.....	P8P
Ion.....	P8N
Iris.....	P8J
Krypton.....	P8F
Ochre.....	P093
Regatta.....	P8M
Sienna.....	P092
Succulent***.....	P8A

***These colors are intended to be an inspirational option for the trending market. Product application is limited and color availability is approximately two years to coincide with evolving workplace trends.

LAMINATES

GRADE L1

SOLID COLOR	
Black.....	P
Brownstone.....	LM13
Bungalow.....	LM12
Designer White.....	LDW1
Flint.....	LM16
Fossil Shale.....	LEH1
Loft.....	LM11
Muslin.....	LM15
Titanium.....	LTI1

ABSTRACT

Handspun Pearl.....	LAHP
Handspun Dove.....	LAHD
Handspun Slate.....	LAHS
Handspun Chestnut.....	LAHC

WOODGRAIN

Belair.....	LWBA
Bourbon Cherry.....	H
Field Elm.....	LWFE
Florence Walnut.....	LFW1
Kingswood Walnut.....	LK11
Natural Maple.....	LWD
NeoWalnut.....	LNU1
Pinnacle.....	PINC
Shaker Cherry.....	LW7C

GRADE L2

Beigewood.....	LWBE
Fawn Cypress.....	LFC1
Lowell Ash.....	LLA1
Mangalore Mango.....	LMM1
Natural Recon.....	LNR1
Phantom Charcoal.....	LPC1
Phantom Ecru.....	LPE1
Portico Teak.....	LPT1
Skyline Walnut.....	LSW1
Veranda Teak.....	LVT1

GRADE L3

Natural Walnut.....	LWNW
---------------------	------

LAMINATE EDGE COLORS

Beigewood.....	DE
Belair.....	BA
Black.....	E4
Bourbon Cherry.....	H
Brownstone.....	EY
Bungalow.....	EX
Designer White.....	DW
Fawn Cypress.....	FC
Field Elm.....	FE
Flint.....	E9
Florence Walnut.....	FW
Fossil.....	EH
Kingswood Walnut.....	KI
Loft.....	EV
Lowell Ash.....	DL
Mangalore Mango.....	MM
Muslin.....	EU
Natural Maple.....	DD
Natural Recon.....	NR
Natural Walnut.....	DN
NeoWalnut.....	NU
Parchment.....	EN
Phantom Charcoal.....	PC
Phantom Ecru.....	PE
Pinnacle.....	PI
Plyband.....	PL
Portico Teak.....	DP
Shaker Cherry.....	DF
Skyline Walnut.....	SW
Titanium.....	TI
Veranda Teak.....	VT

Forest Stewardship Council (FSC) is a non-profit organization devoted to encouraging the responsible management of the world's forests. FSC sets high standards that ensure forestry is practiced in an environmentally responsible, socially beneficial, and economically viable way. Allsteel received its FSC Chain of Custody certification in 2010 and can offer FSC Certified products. Select wood-based products can be ordered as FSC certified, either by choosing the FSC option or selecting an FSC laminate or veneer finish at the time of order. For more information, please contact Customer Support at 888-255-7833. (FSC Trademark license code: FSC-CO14704.)

NOTE: Refer to individual product pages for upcharges.

GRADE A

APPOINT PANEL
100% Polyester

Artichoke.....	APN911
Blackberry.....	APN932
Bronze.....	APN922
Carbon.....	APN928
Chai.....	APN912
Cherry.....	APN930
Dark Pewter.....	APN917
Dune.....	APN915
Espresso.....	APN923
Framboise.....	APN931
Frost.....	APN934
Jet.....	APN927
Lawn.....	APN925
Mandarin.....	APN929
Morel.....	APN909
Nimbus.....	APN916
Platinum.....	APN924
Turquoise.....	APN926

BINARY †

Blush.....	BNRY12
Coal.....	BNRY06
Cream.....	BNRY01
Denim.....	BNRY08
Diamond.....	BNRY03
Graphite.....	BNRY05
Juniper.....	BNRY10
Lagoon.....	BNRY07
Lavendar.....	BNRY11
Mineral.....	BNRY04
Reef.....	BNRY09
Sand Dollar.....	BNRY02

CENTURION^W
(Nanotex™ Stain-Resistant finish)

Apricot.....	CU47
Bark.....	CU25
Black.....	CU10
Espresso.....	CU49
Fog.....	CU03
Frost.....	CU22
Goldenrod.....	CU27
Indigo.....	CU06
Iris.....	CU50
Iron Ore.....	CU19
Jade.....	CU83
Marsala.....	CU63
Morel.....	CU24
Navy.....	CU98
Peacock.....	CU97
Pear.....	CU84
Ruby.....	CU67
Sapphire.....	CU09

CIRCUIT † ♣

Atlas.....	CIRC35
Dolphin.....	CIRC63
Island White.....	CIRC14
Moon.....	CIRC07
Night.....	CIRC49
Pacific.....	CIRC28
Quartz.....	CIRC01
Sienna.....	CIRC56
Silk.....	CIRC21
Snap Pea.....	CIRC42

ETCH
100% Polyester

Axis.....	ECH913
Blend.....	ECH914
Cast.....	ECH912
Highlight.....	ECH910
Midtone.....	ECH911
Outline.....	ECH908
Shade.....	ECH909
Tonal.....	ECH916
Vanish.....	ECH915

GRADE A – continued

EXCHANGE
100% Polyester

Iron.....	EXG916
Nickel.....	EXG914
Pistachio.....	EXG910
Root.....	EXG913
Rupee.....	EXG903
Shadow.....	EXG911
Silver.....	EXG915
Sisal.....	EXG917
Stone.....	EXG912

LANDSCAPE
100% Polyester

Cornsilk.....	LN15
Drift.....	LN05
Khaki.....	LN20
Sheen.....	LN10
Slate.....	LN35
Umber.....	LN25
Urban.....	LN30

LUCY
100% Recycled Polyester

Aspen.....	LC932
Cornsilk.....	LC930
Dusk.....	LC922
Fawn.....	LC933
Graphite.....	LC934
Mist.....	LC920
Neutra.....	LC924
Pewter.....	LC935
Snowdrop.....	LC928

NOBLE

Aegean.....	NBLE18
Amethyst.....	NBLE19
Aspen.....	NBLE14
Aster.....	NBLE20
Blossom.....	NBLE21
Bluebell.....	NBLE22
Bordeaux.....	NBLE01
Brick.....	NBLE02
Chambray.....	NBLE10
Chamomile.....	NBLE23
Clementine.....	NBLE04
Conifer.....	NBLE24
Cottage.....	NBLE25
Darkness.....	NBLE26
Dawn.....	NBLE13
Denim.....	NBLE09
Desert Sand.....	NBLE27
Dewfall.....	NBLE28
Dusted Sage.....	NBLE29
Flax.....	NBLE30
Grass.....	NBLE07
Gunmetal.....	NBLE15
Harmony.....	NBLE31
Harvest.....	NBLE12
Ice Caves.....	NBLE32
Icicle.....	NBLE33
Inky.....	NBLE34
Iris.....	NBLE35
Jade.....	NBLE06
Knight.....	NBLE17
Mesa.....	NBLE03
Monarch.....	NBLE36
Pacific.....	NBLE08
Pitch.....	NBLE37
Queen Bee.....	NBLE38
Rainforest.....	NBLE05
Regal.....	NBLE11
Sandcastle.....	NBLE39
Sedona.....	NBLE40
Stormy.....	NBLE16
Sunbeam.....	NBLE41
Voyager.....	NBLE42
Windy Day.....	NBLE43

GRADE A – continued

REFLECTIONS
100% Recycled Polyester

Galvanized.....	REF929
Ice.....	REF920
Loggia.....	REF921
Mistral.....	REF928
Moonstone.....	REF923
Pewter.....	REF922
Stainless.....	REF924
Vanilla.....	REF925
Winter.....	REF927

REFUGE
64% Recycled Polyester
36% Polyester

Artesian.....	RFG996
Dune.....	RFG992
Eclipse.....	RFG990
Frost †.....	RFG993
Glacier †.....	RFG976
Mineral.....	RFG998
Tidal.....	RFG994

SARTO ▼
100% Polyester (45% Recycled)

Ash.....	SRT988
Fog.....	SRT914
Lemongrass.....	SRT949
Mist.....	SRT945
Mushroom.....	SRT976
Oyster.....	SRT918
Reef.....	SRT964
Sesame.....	SRT993
Shale.....	SRT952

TEMPEST
100% Recycled Polyester

Dragonfly.....	TP930
Frost.....	TP915
Full Stream.....	TP980
Gold Rush.....	TP910
Slate.....	TP945
Tumbleweed.....	TP970
Wind Chill.....	TP940
Zebra.....	TP935

VAST

Vineyard.....	VST01
Garden.....	VST02
Grasslands.....	VST03
Bay.....	VST04
Open Air.....	VST05
Atmosphere.....	VST06
Ocean.....	VST07
Mountain Range.....	VST08
Highway.....	VST09
Tundra.....	VST10
Beach.....	VST11
Desert.....	VST12
Country Side.....	VST13

GRADE B

COAST † ♣
100% Antimony-Free Polyester

Channel.....	COA914
Dune.....	COA903
Headlands.....	COA910
Marsh.....	COA902
Pebble.....	COA912
Pier.....	COA913
Shoal.....	COA901
Silt.....	COA906
Tide.....	COA908

GRADE B – continued

DISPERSE †*
100% Polyester

Autumn.....	DISP03
Branch.....	DISP10
Coffee Bean.....	DISP13
Dusk.....	DISP09
Emerald City.....	DISP08
Gold Rush.....	DISP02
Igloo.....	DISP11
Ink.....	DISP06
Mist.....	DISP12
Oatmeal.....	DISP15
Prince.....	DISP07
Reservoir.....	DISP01
Rose.....	DISP04
Spring.....	DISP05
Steel.....	DISP16
Taupe.....	DISP14

MICA (De-emphasized)
100% Recycled Polyester

Anthracite.....	MCA911
Breeze.....	MCA918
Bronze.....	MCA913
Buff.....	MCA914
Cremini.....	MCA917
Crystal †.....	MCAWIT
Dew.....	MCA920
Dove.....	MCA912
Fresh.....	MCA916
Mineral.....	MCA915
Nectar.....	MCA919
Shale.....	MCA910

SPIN PANEL
46% Recycled Polyester,
56% Polyester

Alabaster.....	SPIN02
Cavern.....	SPIN03
Cobblestone.....	SPIN04
Ember.....	SPIN06
Flame.....	SPIN07
Heron.....	SPIN13
Oat.....	SPIN01
Ocean.....	SPIN12
Plum.....	SPIN15
Pool.....	SPIN11
Raven.....	SPIN10
Rhubarb.....	SPIN14
Tropic.....	SPIN08
Willow.....	SPIN05

TERRAIN
52% Recycled Polyester,
48% Polyester

Bay.....	TRRN05
Bayou.....	TRRN35
Canyon.....	TRRN30
Cliff.....	TRRN45
Crest.....	TRRN25
Delta.....	TRRN10
Plateau.....	TRRN15
Ridge.....	TRRN20
Valley.....	TRRN40

ALLSTEEL PARTNERSHIP PROGRAM

Allsteel understands that customers may want to specify panel and seating textiles outside of Allsteel's standard offering. Allsteel's **Partnership Program** consists of on-trend and design-forward patterns that have been tested and approved by Allsteel for use on Allsteel products. A subset of these approved patterns is available on cards in the textile binder, while numerous others are available on our website, allsteeloffice.com.

For memo samples, please contact our partners:

- Camira, memos@camirafabrics.com
1.616.288.0655
- CF Stinson, cfstinson.com
1.800.841.6279
- HBF Textiles, hbftextiles.com
1.877.494.5727
- Maharam, maharam.com
1.800.645.3943
- Ultrafabrics, ultrafabricsllc.com

The intent of the **Partnership Program** is to offer a wide variety of on-trend textiles to meet your varied needs, but since these textiles are not part of our standard offering they may be subject to extended lead times. Because new materials will be introduced regularly, Allsteel reserves the right to change the offering at any time.

PARTNERSHIP—GRADE D

Camira BLAZER LITE † ▼
(100% Pure New Wool)

Angel.....	PCAMBLT49
Aspire.....	PCAMBLT52
Balance.....	PCAMBLT41
Bliss.....	PCAMBLT48
Buddha.....	PCAMBLT56
Cuddle.....	PCAMBLT62
Dainty.....	PCAMBLT64
Daydream.....	PCAMBLT46
Devoted.....	PCAMBLT58
Faith.....	PCAMBLT68
Freedom.....	PCAMBLT69
Graceful.....	PCAMBLT51
Happy.....	PCAMBLT55
Harmony.....	PCAMBLT63
Haven.....	PCAMBLT40
Hope.....	PCAMBLT50
Hush.....	PCAMBLT42
Love.....	PCAMBLT47
Mood.....	PCAMBLT44
Pamper.....	PCAMBLT66
Pastel.....	PCAMBLT65
Pillow.....	PCAMBLT43
Praise.....	PCAMBLT54
Retreat.....	PCAMBLT39
Shelter.....	PCAMBLT60
Solace.....	PCAMBLT70
Tender.....	PCAMBLT53
True.....	PCAMBLT61
Verity.....	PCAMBLT57
Wish.....	PCAMBLT67
Worship.....	PCAMBLT59

^W Limited to product 48"W or less.

▼ Panel fabric is not available on Further.

♣ Panel fabric is not available on Optimize®.

† Panel fabric is not available on Concensys®.

◆ Panel fabric is not available on Involve.

* Not available on 72"W.

Multi-use fabrics are seating fabrics that can be used on specific Allsteel panels systems, providing more color and pattern options. The applicable Allsteel multi-use fabrics are noted with System designators in the Seating, Collaboration, and Tables Price List.

Paint Recommendations for Gallery-to-Gallery Cover

Laminate	Code	Recommended Paint
Brownstone	LM13	Brownstone
Bungalow	LM12	Bungalow
Designer White 15051	LDW1	Designer White
Flint	LM16	Flint
Fossil Shale	LEH1	Fossil
Loft	LM11	Loft
Muslin	LM15	Muslin
Titanium	LTI1	Titanium
Florence Walnut	LFW1	Cinder, Brownstone, Flint
Kingswood Walnut	LK11	Fossil, Flint, Loft
Natural Maple	LWD	Muslin
NeoWalnut	LNU1	Cinder
Shaker Cherry	LW7C	Black, Cinder
Beigewood	LWBE	Muslin, Loft, Fossil
Fawn Cypress	LFC1	Cinder, Brownstone, Flint
Lowell Ash	LLA1	Cinder
Mangalore Mango	LMM1	Cinder
Natural Recon	LNR1	Cinder, Brownstone
Phantom Charcoal	LPC1	Flint, Salt, Cinder
Phantom Ecu	LPE1	Flint, Brownstone, Muslin
Portico Teak	LPT1	Fossil, Brownstone, Pewter
Skyline Walnut	LSW1	Cinder, Flint, Fossil
Veranda Teak	LVT1	Fossil, Brownstone, Pewter
Natural Walnut	LWNW	Cinder

PANELS:

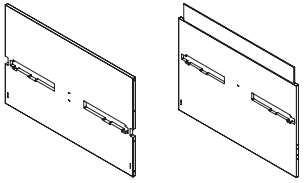

Fit Panel Fit Panel for use with Glass

PANEL CONNECTORS:

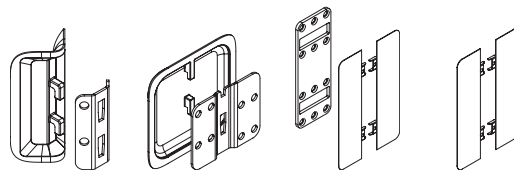

L-Connector Straight In-Line Split End Single End

INTEGRATED GLASS:

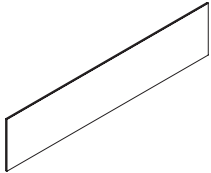

RAILS:

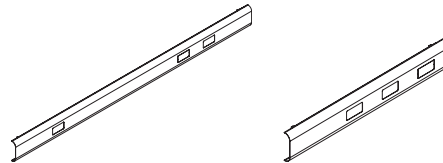

Spine Rail Return Rail

RAIL CONNECTORS:

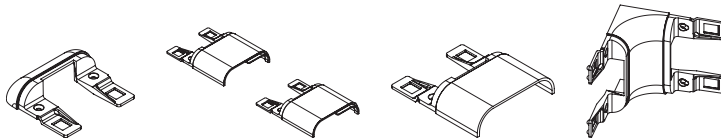

End Cap Straight In-Line Straight Corner L-Connector

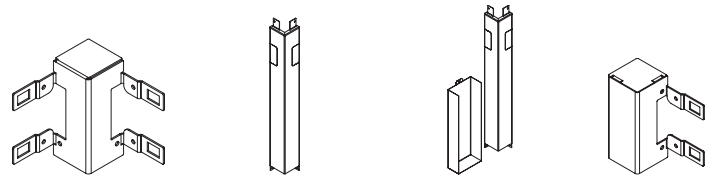

Infeed L-Connector Floor Infeed Cover Hardwire Infeed Cover Infeed Straight Connector

OTHER FIT COMPONENTS:

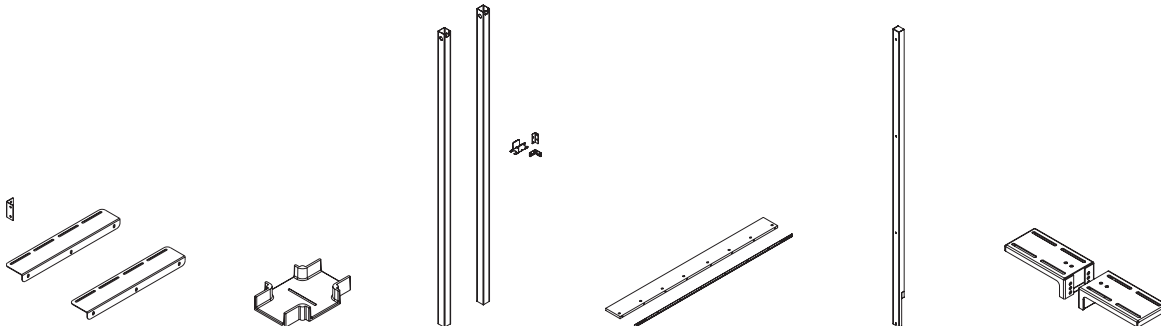

Worksurface Mounting Bracket Kit Installation Template Power Pole Floating Shelves Wall Start Countertop Brackets



Building Horizontally with Fit Panels

Method 1—Opposing Returns

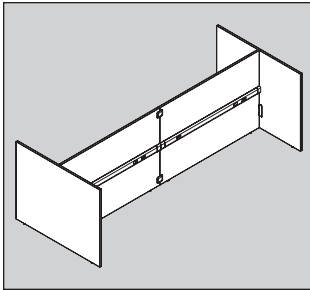

Method 2—Single-Sided Returns

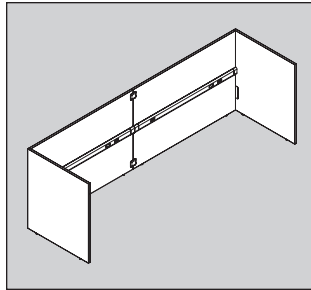

Important planning guidelines: For adequate stability, one of two methods of stabilization must be adhered to:

Method 1 — Opposing returns

- A parent run must be a minimum of 60" and a maximum of 144" between return panels. The parent run must have a minimum of two return panels running in opposing directions on each end of run.
- Dual-sided return panels must be a minimum of 60" combined width.
- Return panels must not be any more than 30" lower than the height of the parent panel run.
- Panel height measurement includes integrated glass, if used.

Method 2 — Single-sided returns

- A parent run must be a minimum of 60" and a maximum of 144" between return panels.
- A parent run less than or equal to 84"W must have a minimum of two return panels totaling 60" in combined width. For every 7½" drop in panel height, 6" must be added to the minimum combined return length.
- A parent run greater than 84"W must have a minimum of two return panels totaling 84" in combined width.
- Return panels must not be any more than 30" lower than the maximum height of the parent panel run.
- Panel height measurement includes integrated glass, if used.

Panels for Use with Glass

- Panels match construction of non-glass panels but have a routed top edge.
- Glass mounts directly into the panel route via a gasket.
- Single end panel routing is inset by ½" from each end of the panel and requires glass to be the same as the panel width, see image.
- Spine, Mid, and Split End panel routing is inset around 1½" from each end of the panel, exact distance will vary with panel type. These panel types require glass to be 3" shorter than the panel width.
- Glass is available in 3 colors: Clear, Frosted, and Smoked.
- Glass height is available in 7½"H, 13"H, and 15"H.
- Glass is available on all panel widths.
- Specify glass models separately from panel models.
- Glass Panels at 30"W and under are not UL listed.

Panel Construction

- Made of 1⅛" board with HPL laminate.
- Can be specified with matching or contrasting edge.
- Edge band is 2mm ABS.
- Available in woodgrain or solid laminates.
- Woodgrain laminates can be specified with vertical grain up to 54"W. Horizontal grain is available on all sizes.
- Grain matching is not available.
- Fit Panels offer 2½" leveling capability.
- Available with and without the integrated glass option. Panels for use with glass offer a routed top edge.
- Glass is specified separately.
- Fit Panels for use with glass have separate model numbers.
- Laminate on Fit Panels is not grain matched.

Panel Dimensions

- Depth: 1⅛"
- Nominal widths: 18", 24", 30", 36", 42", 48", 54", 60", 66", 72", 78"**, and 84"** (actual width dimension will vary based on panel type, see Panel Specification page for details)
- Heights*: 30", 35", 42½", 50", 57½"
- Glass Heights: 7½", 13", 15"
- Leveling Glides: 2½" Range
*with levelers fully retracted
- **Panels 78"W and wider require the use of a stiffener shelf or tube

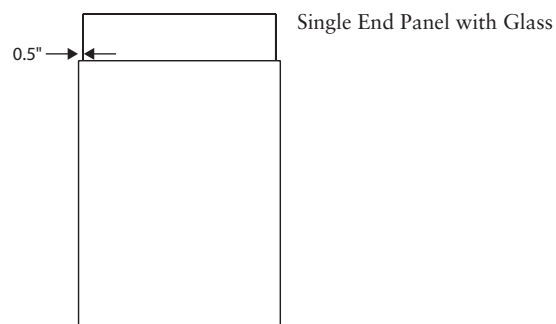
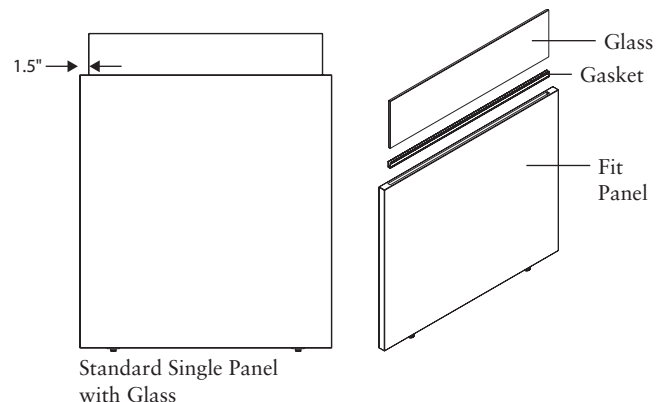

Specifying Fit Panels – Full Model Logic

Panels 18", 24", 30", and 36"W are available in the following configurations:

- Mid Wing, No Power Below Worksurface – ‘MDWPPW’
- Mid Wing, No Power Below HAT – ‘MDWPH’

Panels 42", 48", 50", and 54"W are available in the following configurations:

- Mid Wing, No Power Below Worksurface – ‘MDWPPW’
- Mid Wing, No Power Below HAT – ‘MDWPH’
- Left-Hand Split End, No Power – ‘LPEPN’
- Right-Hand Split End, No Power – ‘RPEPN’

Panels 60"W, 66"W, 72"W, 78"W, 84"W are available in the following configurations:

- Left-Hand Single-Sided End, Single-Side Power Below WS – ‘LSESW’
- Left-Hand Single-Sided End, Single-Side Power Below HAT – ‘LSESH’
- Right-Hand Single-Sided End, Single-Side Power Below WS – ‘RSESW’
- Right-Hand Single-Sided End, Single-Side Power Below HAT – ‘RSESH’
- Left-Hand Split End, Single-Side Power Below WS – ‘LPESW’
- Left-Hand Split End, Single-Side Power Below HAT – ‘LPESH’
- Left-Hand Split End, No Power – ‘LPEPN’
- Right-Hand Split End, Single-Side Power Below WS – ‘RPESW’
- Right-Hand Split End, Single-Side Power Below HAT – ‘RPESH’
- Right-Hand Split End, No Power – ‘RPEPN’
- Left-Hand End Spine, Single-Sided Power Below WS – ‘LESSW’
- Left-Hand End Spine, Single-Sided Power Below HAT – ‘LESSH’
- Left-Hand End Spine, Dual-Sided Power Below WS – ‘LESWS’
- Left-Hand End Spine, Dual-Sided Power Below HAT – ‘LESWSH’
- Right-Hand End Spine, Single-Sided Power Below WS – ‘RESSW’
- Right-Hand End Spine, Single-Sided Power Below HAT – ‘RESSH’
- Right-Hand End Spine, Dual-Sided Power Below WS – ‘RESWS’
- Right-Hand End Spine, Dual-Sided Power Below HAT – ‘RESWSH’
- Right-Hand End Spine, Dual-Sided Power Below HAT – ‘RESDH’
- Mid Spine, Single-Sided Power Below WS – ‘MSPSW’
- Mid Spine, Single-Sided Power Below HAT – ‘MSPSH’
- Mid Spine, Dual-Sided Power Below WS – ‘MSPDW’
- Mid Spine, Dual-Sided Power Below HAT – ‘MSPDH’
- Single Spine, Single-Sided Power Below WS – ‘SGSSW’
- Single Spine, Single-Sided Power Below HAT – ‘SGSSH’
- Single Spine, Dual-Sided Power Below WS – ‘SGSDW’
- Single Spine, Dual-Sided Power Below HAT – ‘SGSDH’
- Mid Wing, Right-Hand Single-Sided Power Below WS – ‘MDWRW’
- Mid Wing, Right-Hand Single-Sided Power Below HAT – ‘MDWRH’
- Mid Wing, Left-Hand Single-Sided Power Below WS – ‘MDWLW’
- Mid Wing, Left-Hand Single-Sided Power Below HAT – ‘MDWLH’
- Mid Wing, Dual-Sided Power Below WS – ‘MDWDW’
- Mid Wing, Dual-Sided Power Below HAT – ‘MDWDH’
- Mid Wing, No Power Below WS – ‘MDWPPW’
- Mid Wing, No Power Below HAT – ‘MDWPH’

Panel Type			Hand	Power Height	Panel Width					
					18"-36"		42"-54"		60"-84"	
					Single Sided	Dual Sided	Single Sided	Dual Sided	Single Sided	Dual Sided
1	End Spine	Power	Left	Below Wks	-	-	-	-	LESSW	LESDDW
				Below HAT	-	-	-	-	LESSH	LESDDH
			Right	Below Wks	-	-	-	-	RESSW	RESDDW
				Below HAT	-	-	-	-	RESSH	RESDDH
2	Mid Spine	Power	None	Below Wks	-	-	-	-	MSPSW	MSPDW
				Below HAT	-	-	-	-	MSPSH	MSPDH
3	Single Spine	Power	None	Below Wks	-	-	-	-	SGSSW	SGSDW
				Below HAT	-	-	-	-	SGSSH	SGSDH
4	Split End	Power	Left	Below Wks	-	-	-	-	LPESW	-
				Below HAT	-	-	-	-	LPESH	-
			Right	Below Wks	-	-	-	-	RPESW	-
				Below HAT	-	-	-	-	RPESH	-
		No Power	Left	Same	-	-	LPEPN	-	LPEPN	-
				Same	-	-	RPEPN	-	RPEPN	-
5	Single-Sided End	Power	Left	Below Wks	-	-	-	-	LSESW	-
				Below HAT	-	-	-	-	LSESH	-
			Right	Below Wks	-	-	-	-	RSESW	-
				Below HAT	-	-	-	-	RSESH	-
		No Power	Left	Same	GLxxyyL	-	GLxxyyL	-	GLxxyyL Max 78"	-
				Same	GLxxyyR	-	GLxxyyR	-	GLxxyyR Max 78"	-
6	Mid Wing	Power	Left	Below Wks	-	-	-	-	MDWLW	MDWDW
				Below HAT	-	-	-	-	MDWLH	MDWDH
			Right	Below Wks	-	-	-	-	MDWRW	MDWDW
				Below HAT	-	-	-	-	MDWRH	MDWDH
		No Power	None	Below Wks	-	MDWPW	-	MDWPW	-	MDWPW
				Below HAT	-	MDWPH	-	MDWPH	-	MDWPH

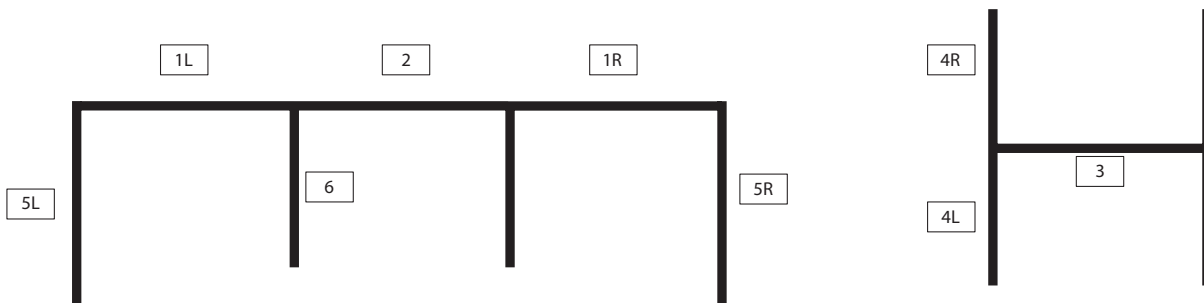

Specifying Fit Panels

- When specifying Fit Panels, the base model indicates the height and modular width needed. Model logic is 'GSYS' then 'height' then 'width.' (e.g., a 50"H by 72"W panel would be GSYS5072)
- The first dot option indicates the panel type (where the panel is located within the typical) and power options. (e.g., GSYS5072.MSPDW (Mid Spine, Power Below Worksurface, Wall))
- When a Single-sided End panel is ordered, a separate connector must be specified (GPLTBK) with any Allsteel standard paint color.
- When Split End panels are ordered, a separate connector must be specified (GSYSCONSE) with any Allsteel standard paint color.
- Due to the lack of connectors spacing out the panels, the true width of Fit panels must accommodate panel overlap. To allow for modular interior worksurface dimensions, the option codes must indicate how much overlap is needed, which is done by specifying 'panel type' explained below.
- Spine panels must be the tallest panels in the run. No variable height along the spine panel run is allowed.

Panel Type Options are below:	True Panel Widths (ex: 72"W)	Glass Widths
Mid Wing = "MDW"	Exact width (72")	3" Undersized
Left Hand Split End = "LPE"	1/2 panel width overlap (72.56" W)	3" Undersized
Right Hand Split End = "RPE"	1/2 panel width overlap (72.56" W)	3" Undersized
Left Hand Single-Sided End = "LSE"	1 panel width overlap (73.125" W)	Same width as panel
Right Hand Single-Sided End = "RSE"	1 panel width overlap (73.125" W)	Same width as panel
Right Hand End Spine = "RES"	1/2 panel width overlap (72.56" W)	3" Undersized
Left Hand End Spine = "LES"	1/2 panel width overlap (72.56" W)	3" Undersized
Mid Spine = "MSP"	1 panel width overlap (73.125" W)	3" Undersized
Single Spine = "SGS"	Exact width (72")	3" Undersized

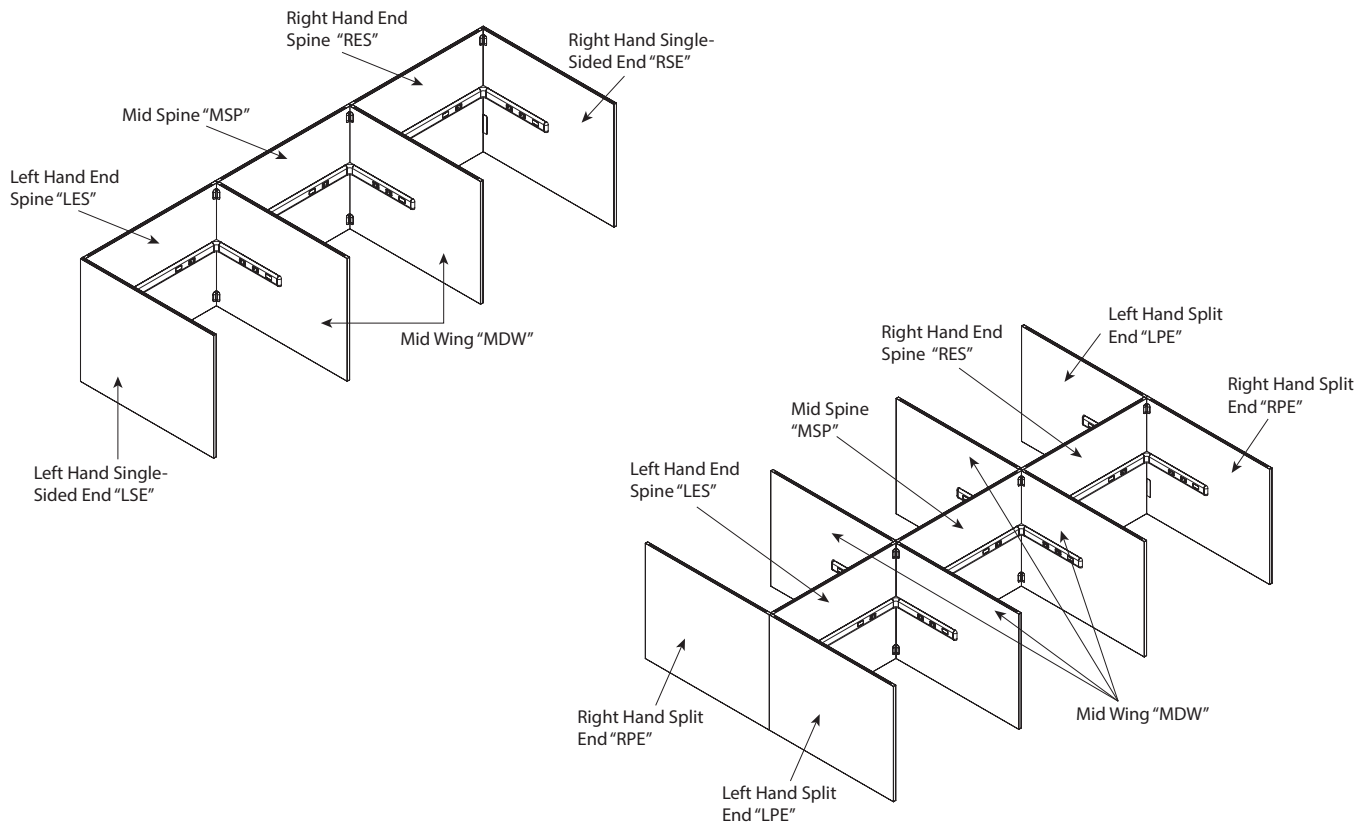

- For Non-Powered End Panels (Single or Dual-Sided), Gallery-to-Gallery 'L' or 'T' Models should be used. Gray panels indicate Gallery-to-Gallery.
- GTEMP model is required for connecting Gallery-to-Gallery Panels to Fit panels.

SIZING DIFFERENCES IN SINGLE SPINES VS. RIGHT HAND/LEFT HAND END SPINES

- Left-Hand and Right-Hand End Spines are .56" wider than Single Spines (SGS) to accommodate exact dimensions inside a workstation area when, for example, a Mid-Wing is added to create separation between workstations in a longer parent run.
- If adding a Mid-Wing to a Parent Run, utilize Left-Hand and Right-Hand Panels for exact dimensions inside of workstations. The shorter Straight Corner Rail Connector, GSYSRSC (requires qty. 2, 1-packs), must be used to close gaps between the power rail and Mid Wing. If not utilizing a Mid Wing in Left-Hand/Right-Hand End Spines, the longer Straight In-Line Connector, GSYRSL (requires qty. 1, 2-pack) must be used to close gap in power rail across Parent Run.
- If not adding Mid-Wing to any side of a Parent Run, exact width Single Spines are recommended to maintain exact dimensions inside work station area(s). The shorter Straight Corner Rail Connector, GSYRSC (requires qty. 2, 1-packs) must be used to close gap in power rail across Parent Run.

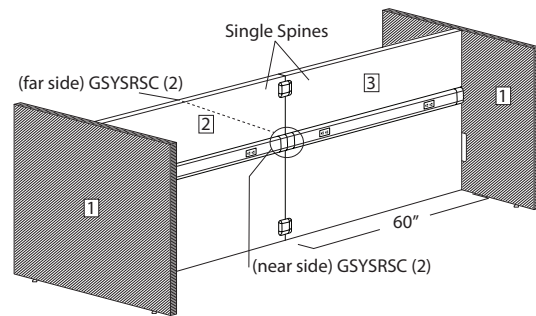
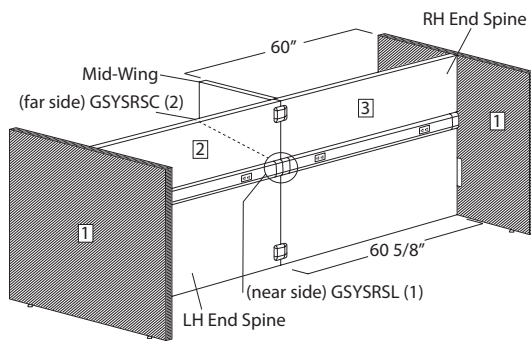

1. GThhww (Gallery-to-Gallery T Panel)
2. GSYShhww.LESDW (Left Hand End Spine)
3. GSYShhww.RESDW (Right hand End Spine)

- Gallery-to-Gallery Panels can also be connected to Fit Wing or End panels as an additional return. Gray panels indicate Gallery-to-Gallery.
- GTEMP model is required for connecting Gallery-to-Gallery Panels to Fit panels.

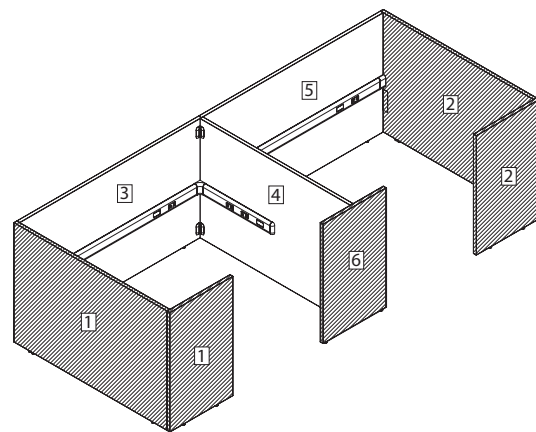
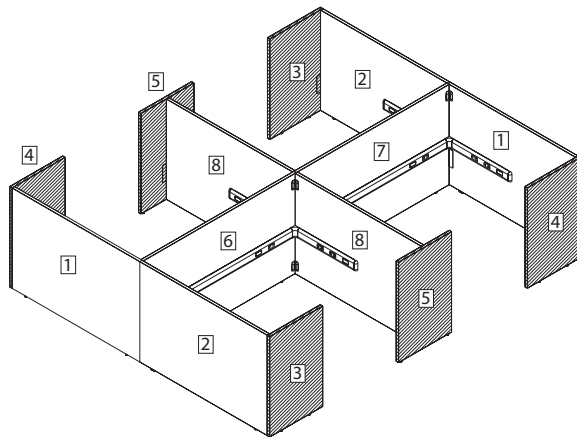

1. GSYShhww.RPESW (Right Hand Split End)
2. GSYShhww.LPESW (Left Hand Split End)
3. GLhwwL (Left Hand Gallery-2-Gallery L)
4. GLhwwR (Right Hand Gallery-2-Gallery L)
5. GThhww (Gallery-2-Gallery T)
6. GSYShhww.LESDW (Left Hand End Spine)
7. GSYShhww.RESDW (Right Hand End Spine)
8. GSYShhww.MDWDW (Mid Wing)

1. GLhwwL (Left Hand Gallery-2-Gallery L)
2. GLhwwR (Right Hand Gallery-2-Gallery L)
3. GSYShhww.LESSW (Left Hand End Spine)
4. GSYShhww.MDWDW (Mid Wing)
5. GSYShhww.RESSW (Right Hand End Spine)
6. GThhww (Gallery-2-Gallery T)

WHEN TO USE "SGS" MODELS

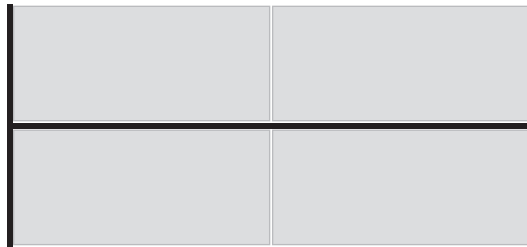

Traditional 4-station benching with fixed surfaces

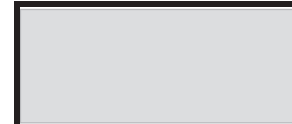

Reception style station

Gallery-to-Gallery Panels (page 143)

- Gallery-to-Gallery Panels connect to Fit panels and are available in L-, T-, and Nonsymmetrical T- configurations.
- When specifying Gallery-to-Gallery Panels, the installation template (GTEMP) is required. The recommendation is 1 template for every 30 panels. Templates are reusable.
- Gallery-to-Gallery Panels cap over Fit panels and are oversized by 1/8" to maintain true interior dimensions.
- Gallery-to-Gallery Panels must be of equal or lower height than the Fit panel attached. The Gallery-to-Gallery Panel cannot be taller than the adjacent panel. If this is required, please reach out to TPG for a custom solution.
- Panel construction is the same as Fit panels.
- Can be specified with matching or contrasting edge.
- Woodgrain laminates can be specified with vertical grain up to 54"W. Horizontal grain is available on all sizes.
- Gallery-to-Gallery Panel widths are available in 3" increments from 18"W to 30"W and in 6" increments from 30"W to 78"W.
- Gallery-to-Gallery Panels offer 2 1/2" leveling capability.
- Overall heights line up with adjacent panel.
- Available with and without the integrated glass option.
- Glass is specified separately.
- Gallery-to-Gallery Panels for use with glass have separate model numbers.
- Gallery-to-Gallery Panels are secured with an inset flat bracket under a painted metal cover at the base and a hidden top connection.
- If Fit Panel L- connectors are preferred at Gallery-to-Gallery attachments for aesthetic reasons, they may be added.
- L- and Nonsymmetrical T- panels are handed.
- Additional support is required after every 60" in panel width (i.e., return panel, storage or worksurface tie-in, panel bracket, or foot).
- Nonsymmetrical T- panels are specified in the format GTyyxxxx. Substitute yy as panel height, xx and LH nominal length, and zz and RH nominal length.

Specifying Fit Panels

Following the 'Panel Type', the option code includes a power specification.

Power options for Spine Panels are below:

- Single-Sided Power Below Worksurface = "SW"
- Single-Sided Power Below HAT = "SH"
- Dual-Sided Power Below Worksurface = "DW"
- Dual-Sided Power Below HAT = "DH"

Power options for End Panels are below:

- No Power = "PN"
- Single-Sided Power Below Worksurface = "SW"
- Single-Sided Power Below HAT = "SH"

Power options for Mid-Wing Panels are below:

- No Power Below Worksurface = "PW"
- No Power Below HAT = "PH"
- Left-Handed Single-Sided Power Below Worksurface = "LW"
- Left-Handed Single-Sided Power Below HAT = "LH"
- Right-Handed Single-Sided Power Below Worksurface = "RW"
- Right-Handed Single-Sided Power Below HAT = "RH"
- Dual-Sided Power Below Worksurface = "DW"
- Dual-Sided Power Below HAT = "DH"

Electrical Rail (page 48)

- Panels 60" W and larger can be specified with integrated power.
- Rail offers 2 receptacle locations and an optional knock-out location for data.
- Includes attachment hardware for mounting onto the panel.
- Rail protrudes 1" from the face of the panel, with receptacles protruding an additional ¼". Note any potential interference with workstation components. (See Casegoods & Storage Pricer.)
- Rails must be specified to cover electrical components when using a powered panel.
- Spine panels require the rail to be specified at the same width as the panel.
- Powered Wing or End panels require a return rail since power is only integrated within the first 36" past the spine.
- Rails can be specified as single- or dual-sided.
- Can be painted any Allsteel Standard Paint color.
- Electrical can be placed at two different heights on the panel face, Below Worksurface and Below HAT, see dimensions below. Rail models are the same regardless of height.
- Below Worksurface is intended for use below fixed worksurfaces or above low storage.
- Below HAT is intended for use below a Height-Adjustable table.
- Ordering two single-sided rail models is not a substitute for one dual-sided model, and vice-versa.

Below Worksurface Height

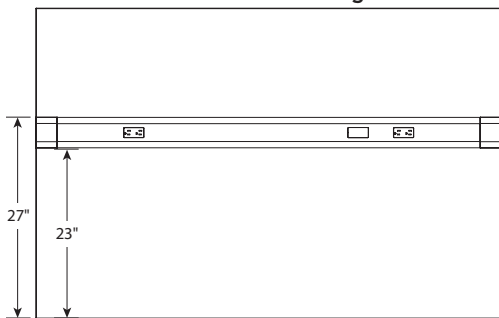

Below HAT Height

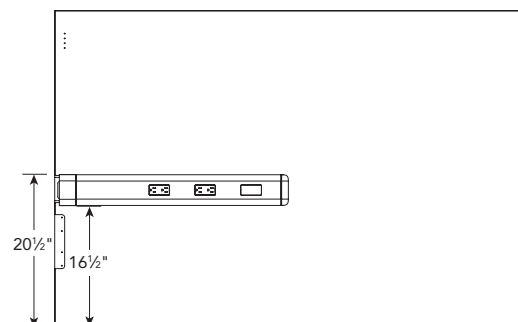
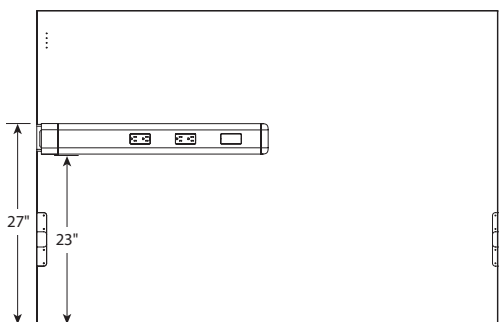
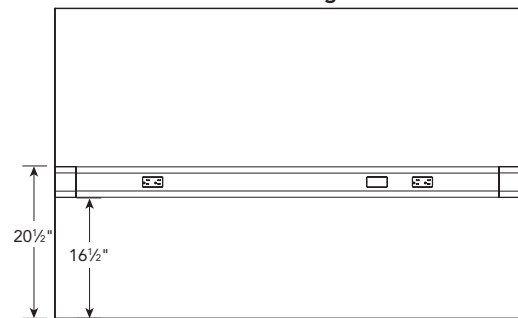

Worksurface Mounting Bracket (page 47)

- Used to mount a fixed-height worksurface to a Fit panel.
 - Can be painted any Allsteel Standard Paint color.
 - A worksurface stiffener is required for surfaces 60" W or greater.
 - One bracket kit (GWSBK) is required for each worksurface corner attached to Fit panels.
 - Sized to fit above a Below Worksurface power rail location and locate the top of a fixed worksurface at 29¼" above the floor. Or can be installed at any available height.
 - When using a 30"H spine with a below worksurface rail, a worksurface or storage must be mounted at any panel-to-panel connection.
- Worksurface sits flush with FIT panels. For mounting desk mounted accessories (Monitor arms, Power Modules, etc.) please specify either grommets in worksurface or use special undersized worksurface through the 9120 program.

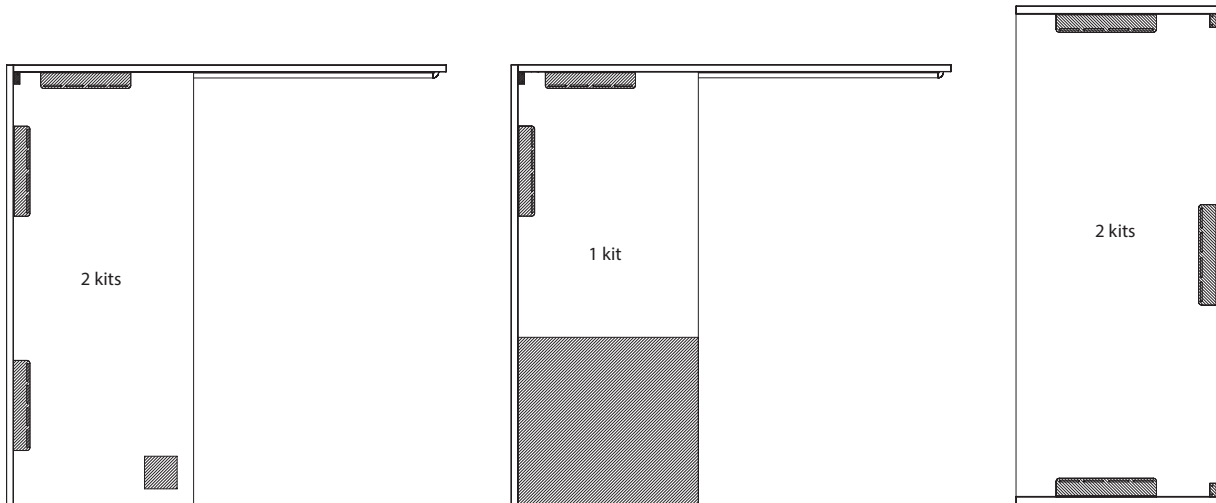
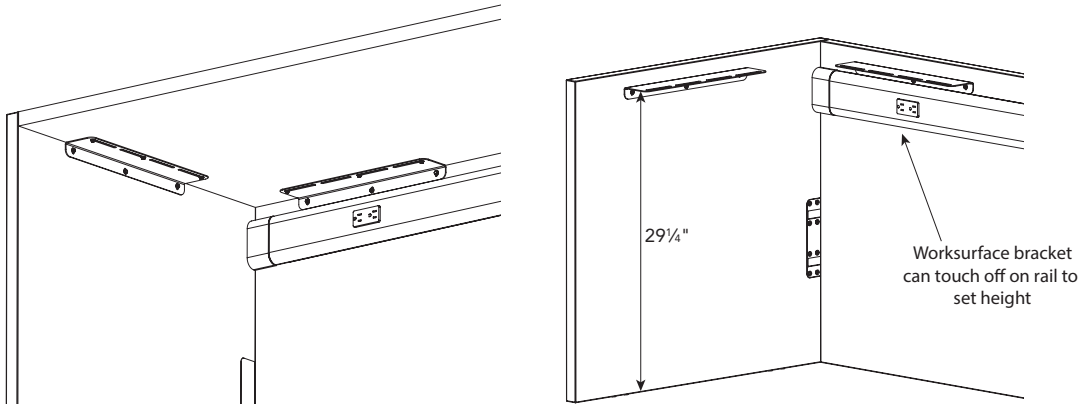

Storage Ganging Kits (page 47)

- The laminate storage ganging kit (GSGKL) is used to connect a Fit panel to a laminate storage unit.
- The metal storage ganging kit (GSGKM) is used to connect a Fit panel to a metal storage unit.

Credenzas & Towers

- Approach low credenzas w/ trough and Align low credenzas sit below rail. (Below Worksurface height only.)
- Rail will offset taller storage, like towers, from panel by 1".
- Infeed housing will interfere with storage units when placed in the same corner.

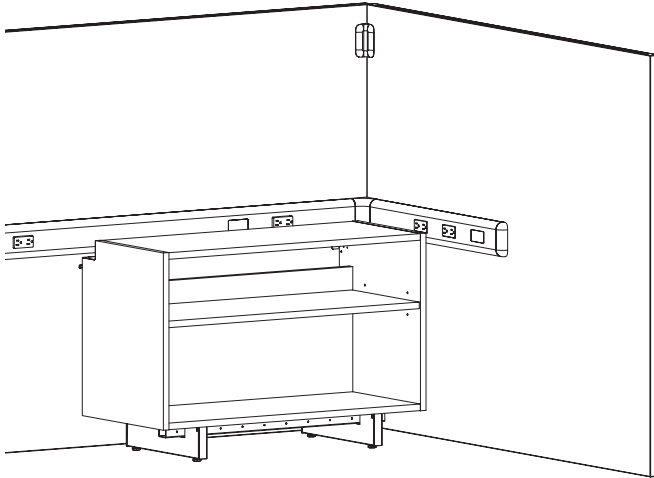

NOTE: A topper used on an Approach credenza may interfere with the ability to plug into the rail. Credenza will need to be offset from the panel.

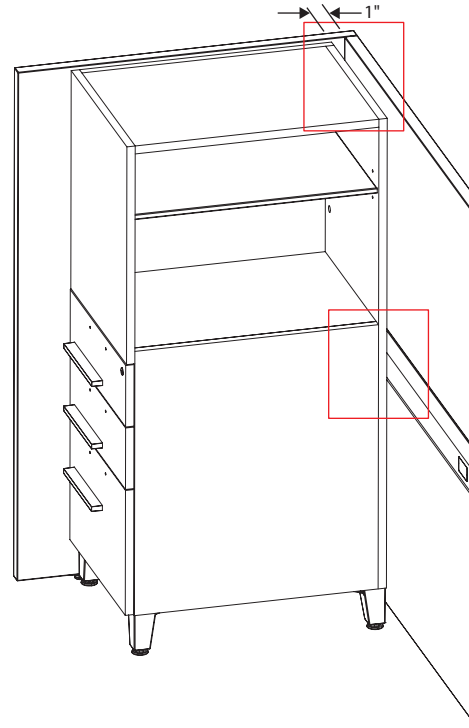

Support Pedestals

- Further, Involve, and Align support pedestals match height of worksurface brackets and can be recommended for worksurface support.
- Cannot use full-depth support storage that matches worksurface depth due to rail interference.

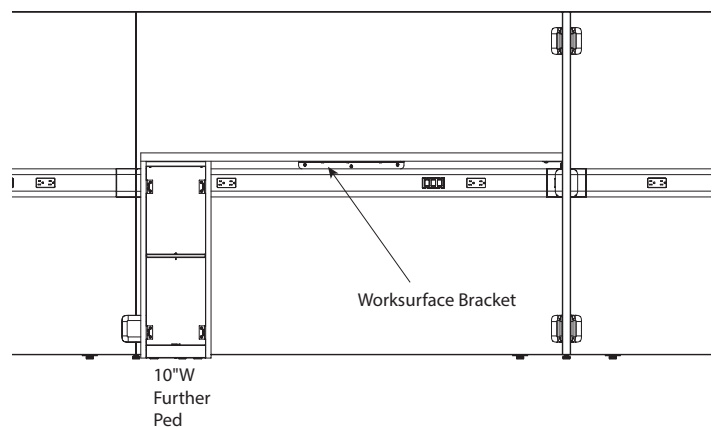
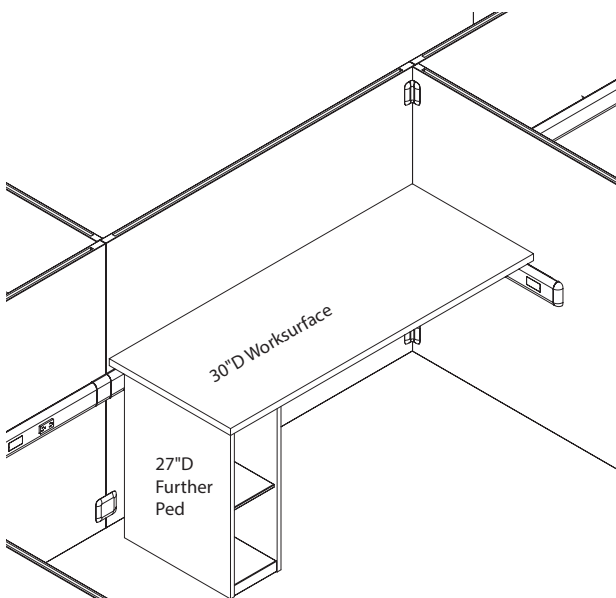

Rail Connectors (page 48)

- Rail connectors must be used at BOTH ends of each rail to create the proper transition.
- Rail connectors are painted metal and can be painted to match the rail color.

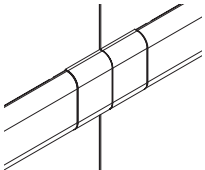
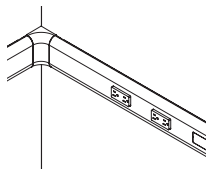
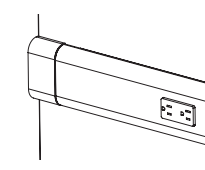
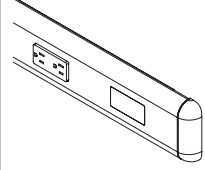
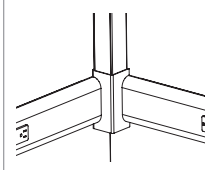
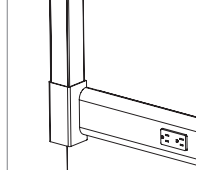
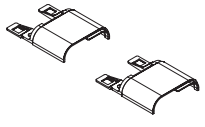
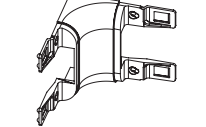
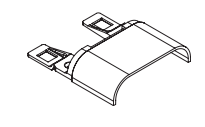
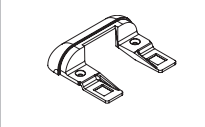
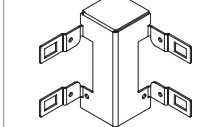
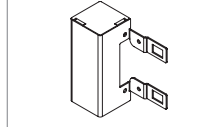
					
					
GSYSRSL Straight In-Line Connection (No Mid Panel between Spine Panels)	GSYSRL L-Connection (Between Powered Spine and Powered Wing)	GSYSRSC Straight Corner Connection (Between Powered Spine and Non-Powered Wing)	GSYSREC End Cap (At the end of any Return Rail)	GSYSRPL* L- Infeed Connection (Infeed between Powered Spine and Powered Wing)	GSYSRPS* Straight Corner Infeed (Infeed between Powered Spine and Non-Powered Wing)

*Models replace GSYSRL or GSYRSRC

Rail Hardwire Infeed Connectors (page 48)

- Rail Hardwire infeed connectors are for use where a hardwired infeed comes into the rail.

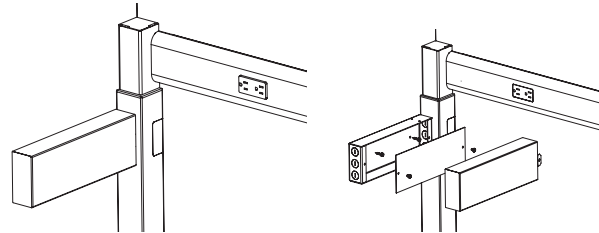

Panel Connectors (page 47)

- Panel connectors must be used at each panel connection

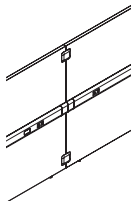
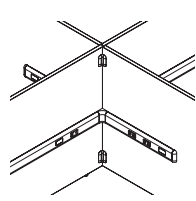
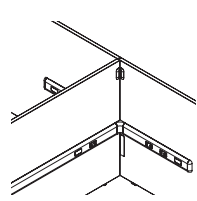
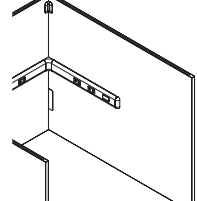
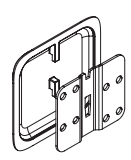
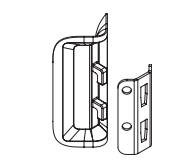
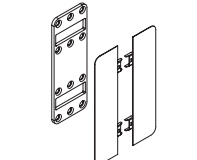
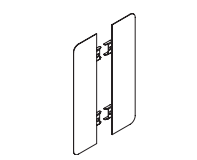
			
			
GSYSCONS Straight In-Line Connection (No Mid Panel between Spine Panels) No In-line panel connector is needed if 1 or more wing panels are connected to the spine at the panel intersection	GSYSCONL L-Connection (Between Spine and Mid Wing) Each Mid Panel requires 2 kits – unless storage is ganged at the base, then 1 kit is needed	GSYSCONSE Split Panel connection at the End of the Run (Split panels also require 1 L-Bracket kit GSYSCONL to be specified)	GPLTBK Single Powered Panel connection at the End of the Run (Single Powered panels also require 1 L-Bracket kit GSYSCONL to be specified)

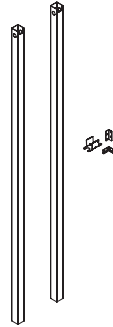
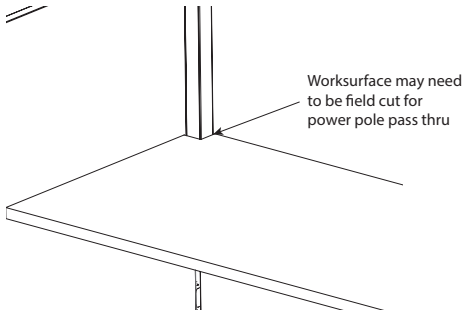

Power Pole (page 65)

- Ceiling power pole for use with ceiling in-feeds.
- Ceiling power poles connect to the rail inside of workstation, in this instance a mounted work surface or HAT may need to be field-cut to accommodate. (See image at right.)
- Below HAT Power Pole is used to shroud a base or wall in-feed as it connects into a Below HAT Rail Height.
- Below Worksurface Power Pole is used to shroud a base or wall in-feed as it connects into a Below Worksurface Rail Height.
- Power Pole height is 13 feet.

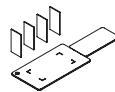
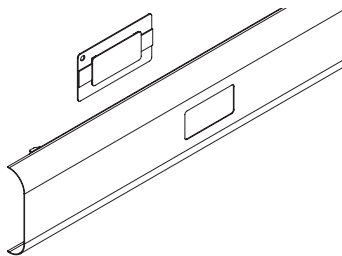

Rail Port Cover (page 65)

- Offered in a 2- or 12-pack.
- Used to cover a port location in a rail when a receptacle is not needed.
- Can be painted any Allsteel Standard Paint color.

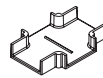
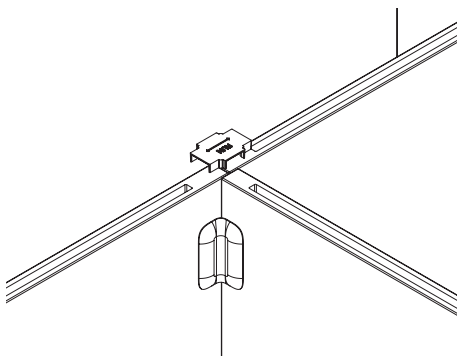

Installation Template (page 47)

- At least one required at installation, recommended that at least one is ordered per project.

Specifying Fit Panels

- Panels under 60"W are not available with power.
- Panels 60"W and greater are available with single- or dual-sided power.
- Spine panels are only available 60"W or greater and must be specified with power.
- Specify L- or T- Gallery-to-Gallery Panels when power is not needed in a single-piece end panel.
- Split End panels may be specified with or without single-sided power.
- When power is not needed in Mid Wing Panels, they must be specified with No Power AND the spine power height in order to allow electrical components to pass through the panel. Power can be specified at the Below Worksurface or Below HAT heights.
- A dual-sided powered spine must have an end panel that extends both directions:

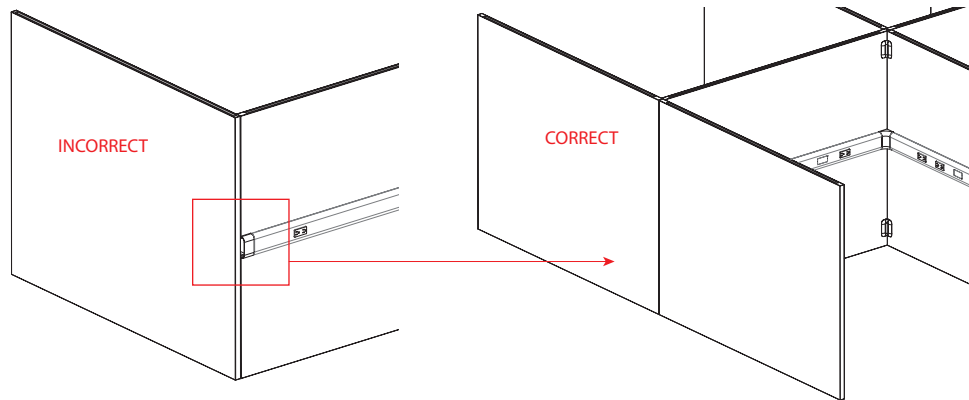

- When using a mid wing on the EXTERIOR face of a single-sided powered spine, use a standard Gallery Panel. Connectors must be field-measured.

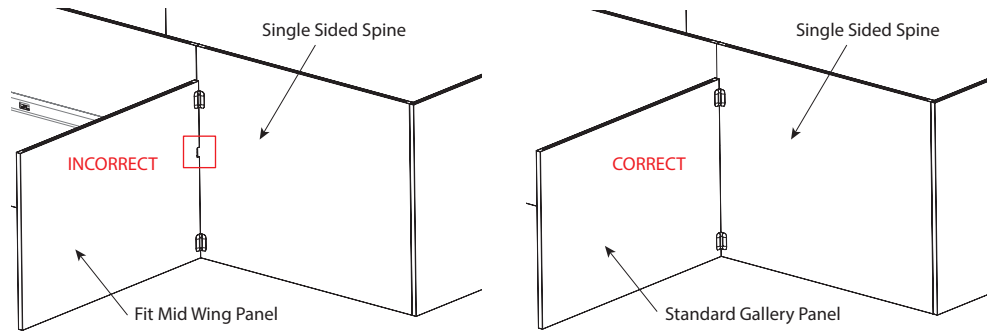

- When submitting a request to TPG, the full dot option logic must be provided.

Panels

Fit 30"H Panels

For specification information see pages 21-51.

GSA SIN Pending

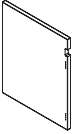

Description	Model	L1 List Price	L2 List Price	L3 List Price
30"H Panels				
18"W	GSYS3018	\$ 498	\$ 520	\$ 541
24"W	GSYS3024 (shown)	\$ 546	\$ 569	\$ 593
30"W	GSYS3030	\$ 657	\$ 686	\$ 713
36"W	GSYS3036	\$ 728	\$ 759	\$ 789

How to specify — Select the Model Number from above.	1st Option: Panel and Power Type: MDWPW Mid wing, no power below WS MDWPH Mid Wing no power below HAT	2nd Option: FSC: F FSC Wood X Non-FSC Wood	3rd Option: Laminate: See page 18 for finishes.	4th Option: Edge: See page 18 for finishes.	5th Option: Grain: VLG Horizontal grain or Solid only VST Vertical Grain (available only for single panels 54" W or less)	6th Option: Glide:
	G V . G					

Example: GSYS3024.MDWPH.X.LDW1.DW.VLG.G

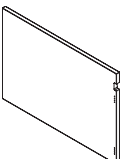

Description	Model	L1 List Price	L2 List Price	L3 List Price
30"H Panels				
42"W	GSYS3042 (shown)	\$ 843	\$ 879	\$ 915
48"W	GSYS3048	\$ 957	\$ 999	\$ 1038
54"W	GSYS3054	\$ 1018	\$ 1062	\$ 1104

How to specify — Select the Model Number from above.	1st Option: Panel and Power Type: MDWPW Mid wing, no power below WS MDWPH Mid Wing no power below HAT LPEPN Left Hand Split End no power RPEPN Right Hand Split End no power	2nd Option: FSC: F FSC Wood X Non-FSC Wood	3rd Option: Laminate: See page 18 for finishes.	4th Option: Edge: See page 18 for finishes.	5th Option: Grain: VLG Horizontal grain or Solid only VST Vertical Grain (available only for single panels 54" W or less)	6th Option: Glide:
	G V . G					

Example: GSYS3042.LPEPN.X.LDW1.DW.VLG.G

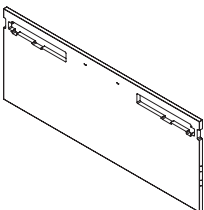

Description	Model	L1 List Price	L2 List Price	L3 List Price
30"H Panels				
60"W	GSYS3060	\$ 1111	\$ 1158	\$ 1205
66"W	GSYS3066	\$ 1150	\$ 1199	\$ 1247
72"W	GSYS3072 (shown)	\$ 1263	\$ 1317	\$ 1370
78"W	GSYS3078	\$ 1481	\$ 1543	\$ 1606
84"W	GSYS3084	\$ 1676	\$ 1748	\$ 1818

How to specify — Select the Model Number from above.	1st Option: Panel and Power Type: See page 23-24 for options.	2nd Option: FSC: F FSC Wood X Non-FSC Wood	3rd Option: Laminate: See page 18 for finishes.	4th Option: Edge: See page 18 for finishes.	5th Option: Grain: VLG Horizontal grain or Solid only	6th Option: Glide:
	G V L G . G					

Example: GSYS3072.MSPSH.X.LDW1.DW.VLG.G

Panels

Fit 35"H Panels

For specification information see pages 21-51.

GSA SIN Pending

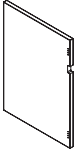

Description	Model	L1 List Price	L2 List Price	L3 List Price
35"H Panels				
18"W	GSYS3518	\$ 599	\$ 624	\$ 651
24"W	GSYS3524 (shown)	\$ 654	\$ 682	\$ 710
30"W	GSYS3530	\$ 786	\$ 819	\$ 853
36"W	GSYS3536	\$ 871	\$ 909	\$ 945

How to specify — Select the Model Number from above.	1st Option: Panel and Power Type: MDWPW Mid wing, no power below WS MDWPH Mid Wing no power below HAT	2nd Option: FSC: F FSC Wood X Non-FSC Wood	3rd Option: Laminate: See page 18 for finishes.	4th Option: Edge: See page 18 for finishes.	5th Option: Grain: VLG Horizontal grain or Solid only VST Vertical Grain (available only for single panels 54" W or less)	6th Option: Glide:	
	G	V	.

Example: GSYS3524.MDWPH.X.LDW1.DW.VLG.G

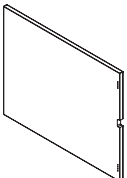

Description	Model	L1 List Price	L2 List Price	L3 List Price
35"H Panels				
42"W	GSYS3542 (shown)	\$ 969	\$ 1011	\$ 1051
48"W	GSYS3548	\$ 1066	\$ 1112	\$ 1157
54"W	GSYS3554	\$ 1139	\$ 1187	\$ 1235

How to specify — Select the Model Number from above.	1st Option: Panel and Power Type: MDWPW Mid wing, no power below WS MDWPH Mid Wing no power below HAT LPEPN Left Hand Split End no power RPEPN Right Hand Split End no power	2nd Option: FSC: F FSC Wood X Non-FSC Wood	3rd Option: Laminate: See page 18 for finishes.	4th Option: Edge: See page 18 for finishes.	5th Option: Grain: VLG Horizontal grain or Solid only VST Vertical Grain (available only for single panels 54" W or less)	6th Option: Glide:	
	G	V	.

Example: GSYS3542.LPEPN.X.LDW1.DW.VLG.G

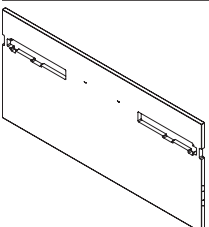

Description	Model	L1 List Price	L2 List Price	L3 List Price
35"H Panels				
60"W	GSYS3560	\$ 1221	\$ 1274	\$ 1324
66"W	GSYS3566	\$ 1281	\$ 1336	\$ 1390
72"W	GSYS3572 (shown)	\$ 1402	\$ 1461	\$ 1521
78"W	GSYS3578	\$ 1583	\$ 1650	\$ 1716
84"W	GSYS3584	\$ 1853	\$ 1932	\$ 2009

How to specify — Select the Model Number from above.	1st Option: Panel and Power Type: See page 23-24 for options.	2nd Option: FSC: F FSC Wood X Non-FSC Wood	3rd Option: Laminate: See page 18 for finishes.	4th Option: Edge: See page 18 for finishes.	5th Option: Grain: VLG Horizontal grain or Solid only	6th Option: Glide:		
	G	V	LG	.

Example: GSYS3572.MSPSH.X.LDW1.DW.VLG.G

Panels

Fit 42"H Panels

For specification information see pages 21-51.

GSA SIN Pending

Description	Model	L1 List Price	L2 List Price	L3 List Price
42"H Panels				
18"W	GSYS4218	\$ 654	\$ 682	\$ 710
24"W	GSYS4224 (shown)	\$ 712	\$ 743	\$ 772
30"W	GSYS4230	\$ 858	\$ 895	\$ 931
36"W	GSYS4236	\$ 950	\$ 991	\$ 1031

How to specify — Select the Model Number from above. G V . G	1st Option: Panel and Power Type: MDWPW Mid wing, no power below WS MDWPH Mid Wing no power below HAT	2nd Option: FSC: F FSC Wood X Non-FSC Wood	3rd Option: Laminate: See page 18 for finishes.	4th Option: Edge: See page 18 for finishes.	5th Option: Grain: VLG Horizontal grain or Solid only VST Vertical Grain (available only for single panels 54" W or less)	6th Option: Glide:
---	---	---	--	--	---	-------------------------------------

Example: GSYS4224.MDWPH.X.LDW1.DW.VLG.G

Description	Model	L1 List Price	L2 List Price	L3 List Price
42"H Panels				
42"W	GSYS4242 (shown)	\$ 1056	\$ 1101	\$ 1146
48"W	GSYS4248	\$ 1137	\$ 1185	\$ 1233
54"W	GSYS4254	\$ 1239	\$ 1292	\$ 1344

How to specify — Select the Model Number from above. G V . G	1st Option: Panel and Power Type: MDWPW Mid wing, no power below WS MDWPH Mid Wing no power below HAT LPEPN Left Hand Split End no power RPEPN Right Hand Split End no power	2nd Option: FSC: F FSC Wood X Non-FSC Wood	3rd Option: Laminate: See page 18 for finishes.	4th Option: Edge: See page 18 for finishes.	5th Option: Grain: VLG Horizontal grain or Solid only VST Vertical Grain (available only for single panels 54" W or less)	6th Option: Glide:
---	--	---	--	--	---	-------------------------------------

Example: GSYS4242.LPEPN.X.LDW1.DW.VLG.G

Description	Model	L1 List Price	L2 List Price	L3 List Price
42"H Panels				
60"W	GSYS4260	\$ 1314	\$ 1370	\$ 1425
66"W	GSYS4266	\$ 1391	\$ 1450	\$ 1509
72"W	GSYS4272 (shown)	\$ 1496	\$ 1560	\$ 1623
78"W	GSYS4278	\$ 1641	\$ 1711	\$ 1781
84"W	GSYS4284	\$ 1966	\$ 2049	\$ 2132

How to specify — Select the Model Number from above. G V . G	1st Option: Panel and Power Type: See page 23-24 for options.	2nd Option: FSC: F FSC Wood X Non-FSC Wood	3rd Option: Laminate: See page 18 for finishes.	4th Option: Edge: See page 18 for finishes.	5th Option: Grain: VLG Horizontal grain or Solid only	6th Option: Glide:
---	--	---	--	--	--	-------------------------------------

Example: GSYS4272.MSPSH.X.LDW1.DW.VLG.G

Panels

Fit 50"H Panels

For specification information see pages 21-51.

GSA SIN Pending

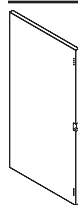

Description	Model	L1 List Price	L2 List Price	L3 List Price
50"H Panels				
18"W	GSYS5018	\$ 754	\$ 786	\$ 818
24"W	GSYS5024 (shown)	\$ 812	\$ 846	\$ 882
30"W	GSYS5030	\$ 946	\$ 987	\$ 1027
36"W	GSYS5036	\$ 1042	\$ 1087	\$ 1131

How to specify — Select the Model Number from above.	1st Option: Panel and Power Type: MDWPP Mid wing, no power below WS MDWPH Mid Wing no power below HAT	2nd Option: FSC: F FSC Wood X Non-FSC Wood	3rd Option: Laminate: See page 18 for finishes.	4th Option: Edge: See page 18 for finishes.	5th Option: Grain: VLG Horizontal grain or Solid only VST Vertical Grain (available only for single panels 54"W or less)	6th Option: Glide:
	G G					

Example: GSYS5024.MDWPH.X.LDW1.DW.VLG.G

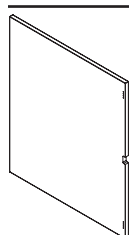

Description	Model	L1 List Price	L2 List Price	L3 List Price
50"H Panels				
42"W	GSYS5042 (shown)	\$ 1160	\$ 1209	\$ 1258
48"W	GSYS5048	\$ 1272	\$ 1326	\$ 1380
54"W	GSYS5054	\$ 1355	\$ 1413	\$ 1470

How to specify — Select the Model Number from above.	1st Option: Panel and Power Type: MDWPP Mid wing, no power below WS MDWPH Mid Wing no power below HAT LPEPN Left Hand Split End no power RPEPN Right Hand Split End no power	2nd Option: FSC: F FSC Wood X Non-FSC Wood	3rd Option: Laminate: See page 18 for finishes.	4th Option: Edge: See page 18 for finishes.	5th Option: Grain: VLG Horizontal grain or Solid only VST Vertical Grain (available only for single panels 54"W or less)	6th Option: Glide:
	G G					

Example: GSYS5042.LPEPN.X.LDW1.DW.VLG.G

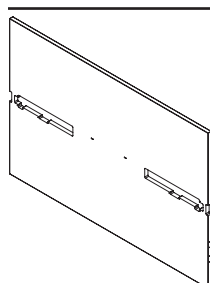

Description	Model	L1 List Price	L2 List Price	L3 List Price
50"H Panels				
60"W	GSYS5060	\$ 1428	\$ 1488	\$ 1549
66"W	GSYS5066	\$ 1498	\$ 1562	\$ 1625
72"W	GSYS5072 (shown)	\$ 1582	\$ 1649	\$ 1715
78"W	GSYS5078	\$ 1843	\$ 1922	\$ 1999
84"W	GSYS5084	\$ 2130	\$ 2221	\$ 2310

How to specify — Select the Model Number from above.	1st Option: Panel and Power Type: See page 23-24 for options.	2nd Option: FSC: F FSC Wood X Non-FSC Wood	3rd Option: Laminate: See page 18 for finishes.	4th Option: Edge: See page 18 for finishes.	5th Option: Grain: VLG Horizontal grain or Solid only	6th Option: Glide:
	G G					

Example: GSYS5072.MSPSH.X.LDW1.DW.VLG.G

FIT

Panels

Fit 57½"H Panels

For specification information see pages 21-51.

GSA SIN Pending

Description	Model	L1	L2	L3
		List Price	List Price	List Price
57½"H Panels				
18"W	GSYS5718	\$ 909	\$ 949	\$ 987
24"W	GSYS5724 (shown)	\$ 967	\$ 1009	\$ 1049
30"W	GSYS5730	\$ 1102	\$ 1149	\$ 1195
36"W	GSYS5736	\$ 1196	\$ 1248	\$ 1297

How to specify — Select the Model Number from above.	1st Option: Panel and Power Type: MDWPH Mid wing, no power below WS MDWPH Mid Wing no power below HAT	2nd Option: FSC: F FSC Wood X Non-FSC Wood	3rd Option: Laminate: See page 18 for finishes.	4th Option: Edge: See page 18 for finishes.	5th Option: Grain: VLG Horizontal grain or Solid only VST Vertical Grain (available only for single panels 54"W or less)	6th Option: Glide:
	G G					

Example: GSYS5724.MDWPH.X.LDW1.DW.VLG.G

Description	Model	L1	L2	L3
		List Price	List Price	List Price
57½"H Panels				
42"W	GSYS5742 (shown)	\$ 1312	\$ 1368	\$ 1423
48"W	GSYS5748	\$ 1424	\$ 1484	\$ 1544
54"W	GSYS5754	\$ 1509	\$ 1573	\$ 1637

How to specify — Select the Model Number from above.	1st Option: Panel and Power Type: MDWPH Mid wing, no power below WS MDWPH Mid Wing no power below HAT LPEPN Left Hand Split End no power RPEPN Right Hand Split End no power	2nd Option: FSC: F FSC Wood X Non-FSC Wood	3rd Option: Laminate: See page 18 for finishes.	4th Option: Edge: See page 18 for finishes.	5th Option: Grain: VLG Horizontal grain or Solid only VST Vertical Grain (available only for single panels 54"W or less)	6th Option: Glide:
	G G					

Example: GSYS5742.LPEPN.X.LDW1.DW.VLG.G

Description	Model	L1	L2	L3
		List Price	List Price	List Price
57½"H Panels				
60"W	GSYS5760	\$ 1583	\$ 1650	\$ 1716
66"W	GSYS5766	\$ 1652	\$ 1723	\$ 1792
72"W	GSYS5772 (shown)	\$ 1734	\$ 1808	\$ 1880
78"W	GSYS5778	\$ 1997	\$ 2082	\$ 2165
84"W	GSYS5784	\$ 2284	\$ 2380	\$ 2477

How to specify — Select the Model Number from above.	1st Option: Panel and Power Type: See page 23-24 for options.	2nd Option: FSC: F FSC Wood X Non-FSC Wood	3rd Option: Laminate: See page 18 for finishes.	4th Option: Edge: See page 18 for finishes.	5th Option: Grain: VLG Horizontal grain or Solid only	6th Option: Glide:
	G G					

Example: GSYS5772.MSPSH.X.LDW1.DW.VLG.G

FIT

Panels

30"H Application for Use with Glass

For Fit Glass see page 44.
For Fit Panel connectors see pages 47-48.

GSA SIN Pending

Description	Model	L1 List Price	L2 List Price	L3 List Price
30"H Fit Panels with Glass				
18"W	GSYS3018G	\$ 730	\$ 761	\$ 791
24"W	GSYS3024G (shown)	\$ 776	\$ 809	\$ 842
30"W	GSYS3030G	\$ 887	\$ 925	\$ 962
36"W	GSYS3036G	\$ 957	\$ 999	\$ 1038

How to specify — Select the Model Number from above.	1st Option: Panel and Power Type: MDWPW Mid wing, no power below WS MDWPH Mid Wing no power below HAT	2nd Option: FSC: F FSC Wood X Non-FSC Wood	3rd Option: Laminate: See page 18 for finishes.	4th Option: Edge: See page 18 for finishes.	5th Option: Grain: VLG Horizontal grain or Solid only VST Vertical Grain (available only for single panels 54"W or less)	6th Option: Glide:
	G 	V .

Example: GSYS3024G.MDWPH.X.LDW1.DW.VLG.G

Description	Model	L1 List Price	L2 List Price	L3 List Price
30"H Fit Panels with Glass				
42"W	GSYS3042G (shown)	\$ 1074	\$ 1120	\$ 1165
48"W	GSYS3048G	\$ 1187	\$ 1237	\$ 1288
54"W	GSYS3054G	\$ 1250	\$ 1304	\$ 1356

How to specify — Select the Model Number from above.	1st Option: Panel and Power Type: MDWPW Mid wing, no power below WS MDWPH Mid Wing no power below HAT LPEPN Left Hand Split End no power RPEPN Right Hand Split End no power	2nd Option: FSC: F FSC Wood X Non-FSC Wood	3rd Option: Laminate: See page 18 for finishes.	4th Option: Edge: See page 18 for finishes.	5th Option: Grain: VLG Horizontal grain or Solid only VST Vertical Grain (available only for single panels 54"W or less)	6th Option: Glide:
	G 	V .

Example: GSYS3042G.LPEPN.X.LDW1.DW.VLG.G

Description	Model	L1 List Price	L2 List Price	L3 List Price
30"H Fit Panels with Glass				
60"W	GSYS3060G	\$ 1343	\$ 1400	\$ 1456
66"W	GSYS3066G	\$ 2089	\$ 2178	\$ 2266
72"W	GSYS3072G (shown)	\$ 2226	\$ 2320	\$ 2413
78"W	GSYS3078G	\$ 2292	\$ 2389	\$ 2485
84"W	GSYS3084G	\$ 2468	\$ 2573	\$ 2676

How to specify — Select the Model Number from above.	1st Option: Panel and Power Type: See page 23-24 for options.	2nd Option: FSC: F FSC Wood X Non-FSC Wood	3rd Option: Laminate: See page 18 for finishes.	4th Option: Edge: See page 18 for finishes.	5th Option: Grain: VLG Horizontal grain or Solid only	6th Option: Glide:
	G 	V L G .

Example: GSYS3072G.MSPSH.X.LDW1.DW.VLG.G

FIT

Panels

35"H Application for Use with Glass

For Fit Glass see page 44.
For Fit Panel connectors see pages 47-48.

GSA SIN Pending

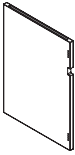

Description	Model	L1 List Price	L2 List Price	L3 List Price
35"H Fit Panels with Glass				
18"W	GSYS3518G	\$ 828	\$ 864	\$ 899
24"W	GSYS3524G (shown)	\$ 883	\$ 921	\$ 958
30"W	GSYS3530G	\$ 1016	\$ 1060	\$ 1102
36"W	GSYS3536G	\$ 1103	\$ 1150	\$ 1196

How to specify — Select the Model Number from above.	1st Option: Panel and Power Type: MDWPW Mid wing, no power below WS MDWPH Mid Wing no power below HAT	2nd Option: FSC: F FSC Wood X Non-FSC Wood	3rd Option: Laminate: See page 18 for finishes.	4th Option: Edge: See page 18 for finishes.	5th Option: Grain: VLG Horizontal grain or Solid only VST Vertical Grain (available only for single panels 54"W or less)	6th Option: Glide:
	G 					

Example: GSYS3524G.MDWPH.X.LDW1.DW.VLG.G

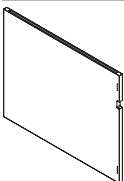

Description	Model	L1 List Price	L2 List Price	L3 List Price
35"H Fit Panels with Glass				
42"W	GSYS3542G (shown)	\$ 1198	\$ 1250	\$ 1299
48"W	GSYS3548G	\$ 1296	\$ 1351	\$ 1406
54"W	GSYS3554G	\$ 1368	\$ 1426	\$ 1484

How to specify — Select the Model Number from above.	1st Option: Panel and Power Type: MDWPW Mid wing, no power below WS MDWPH Mid Wing no power below HAT LPEPN Left Hand Split End no power RPEPN Right Hand Split End no power	2nd Option: FSC: F FSC Wood X Non-FSC Wood	3rd Option: Laminate: See page 18 for finishes.	4th Option: Edge: See page 18 for finishes.	5th Option: Grain: VLG Horizontal grain or Solid only VST Vertical Grain (available only for single panels 54"W or less)	6th Option: Glide:
	G 					

Example: GSYS3542G.LPEPN.X.LDW1.DW.VLG.G

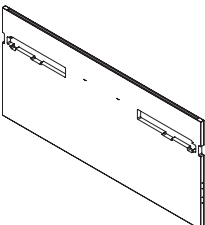

Description	Model	L1 List Price	L2 List Price	L3 List Price
35"H Fit Panels with Glass				
60"W	GSYS3560G	\$ 1453	\$ 1514	\$ 1575
66"W	GSYS3566G	\$ 1513	\$ 1577	\$ 1641
72"W	GSYS3572G (shown)	\$ 1631	\$ 1701	\$ 1768
78"W	GSYS3578G	\$ 1812	\$ 1890	\$ 1965
84"W	GSYS3584G	\$ 2084	\$ 2173	\$ 2261

How to specify — Select the Model Number from above.	1st Option: Panel and Power Type: See page 23-24 for options.	2nd Option: FSC: F FSC Wood X Non-FSC Wood	3rd Option: Laminate: See page 18 for finishes.	4th Option: Edge: See page 18 for finishes.	5th Option: Grain: VLG Horizontal grain or Solid only	6th Option: Glide:
	G 					

Example: GSYS3572G.MSPSH.X.LDW1.DW.VLG.G

FIT

Panels

42"H Application for Use with Glass

For Fit Glass see page 44.
For Fit Panel connectors see pages 47-48.

GSA SIN Pending

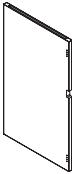
	Description	Model	L1	L2	L3
			List Price	List Price	List Price
	42"H Fit Panels with Glass				
	18"W	GSYS4218G	\$ 883	\$ 921	\$ 958
	24"W	GSYS4224G (shown)	\$ 943	\$ 984	\$ 1023
	30"W	GSYS4230G	\$ 1088	\$ 1135	\$ 1180
	36"W	GSYS4236G	\$ 1183	\$ 1233	\$ 1282

<p><i>How to specify —</i> Select the Model Number from above.</p>	<p><i>1st Option:</i> Panel and Power Type:</p> <p>MDWPW Mid wing, no power below WS MDWPH Mid Wing no power below HAT</p>	<p><i>2nd Option:</i> FSC:</p> <p>F FSC Wood X Non-FSC Wood</p>	<p><i>3rd Option:</i> Laminate:</p> <p>See page 18 for finishes.</p>	<p><i>4th Option:</i> Edge:</p> <p>See page 18 for finishes.</p>	<p><i>5th Option:</i> Grain:</p> <p>VLG Horizontal grain or Solid only VST Vertical Grain (available only for single panels 54"W or less)</p>	<p><i>6th Option:</i> Glide:</p>
	<p>G G</p>					

Example: GSYS4224G.MDWPH.X.LDW1.DW.VLG.G

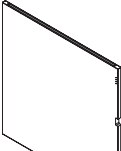
	Description	Model	L1	L2	L3
			List Price	List Price	List Price
	42"H Fit Panels with Glass				
	42"W	GSYS4242G (shown)	\$ 1287	\$ 1342	\$ 1396
	48"W	GSYS4248G	\$ 1366	\$ 1424	\$ 1482
	54"W	GSYS4254G	\$ 1469	\$ 1531	\$ 1593

<p><i>How to specify —</i> Select the Model Number from above.</p>	<p><i>1st Option:</i> Panel and Power Type:</p> <p>MDWPW Mid wing, no power below WS MDWPH Mid Wing no power below HAT LPEPN Left Hand Split End no power RPEPN Right Hand Split End no power</p>	<p><i>2nd Option:</i> FSC:</p> <p>F FSC Wood X Non-FSC Wood</p>	<p><i>3rd Option:</i> Laminate:</p> <p>See page 18 for finishes.</p>	<p><i>4th Option:</i> Edge:</p> <p>See page 18 for finishes.</p>	<p><i>5th Option:</i> Grain:</p> <p>VLG Horizontal grain or Solid only VST Vertical Grain (available only for single panels 54"W or less)</p>	<p><i>6th Option:</i> Glide:</p>
	<p>G G</p>					

Example: GSYS4242G.LPEPN.X.LDW1.DW.VLG.G

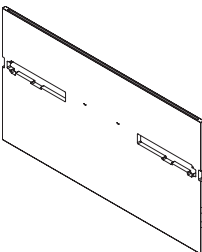
	Description	Model	L1	L2	L3
			List Price	List Price	List Price
	42"H Fit Panels with Glass				
	60"W	GSYS4260G	\$ 1545	\$ 1611	\$ 1675
	66"W	GSYS4266G	\$ 1623	\$ 1693	\$ 1759
	72"W	GSYS4272G (shown)	\$ 1727	\$ 1800	\$ 1873
	78"W	GSYS4278G	\$ 1872	\$ 1952	\$ 2030
	84"W	GSYS4284G	\$ 2196	\$ 2289	\$ 2381

<p><i>How to specify —</i> Select the Model Number from above.</p>	<p><i>1st Option:</i> Panel and Power Type:</p> <p>See page 23-24 for options.</p>	<p><i>2nd Option:</i> FSC:</p> <p>F FSC Wood X Non-FSC Wood</p>	<p><i>3rd Option:</i> Laminate:</p> <p>See page 18 for finishes.</p>	<p><i>4th Option:</i> Edge:</p> <p>See page 18 for finishes.</p>	<p><i>5th Option:</i> Grain:</p> <p>VLG Horizontal grain or Solid only</p>	<p><i>6th Option:</i> Glide:</p>
	<p>G V . G</p>					

Example: GSYS4272G.MSPSH.X.LDW1.DW.VLG.G

FIT

Panels

50"H Application for Use with Glass

For Fit Glass see page 44.
For Fit Panel connectors see pages 47-48.

GSA SIN Pending

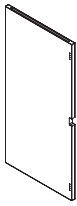

Description	Model	L1 List Price	L2 List Price	L3 List Price
50"H Fit Panels with Glass				
18"W	GSYS5018G	\$ 984	\$ 1027	\$ 1068
24"W	GSYS5024G (shown)	\$ 1043	\$ 1088	\$ 1132
30"W	GSYS5030G	\$ 1177	\$ 1227	\$ 1276
36"W	GSYS5036G	\$ 1273	\$ 1327	\$ 1381

How to specify — Select the Model Number from above. G	1st Option: Panel and Power Type: MDWPH Mid wing, no power below WS MDWPH Mid Wing no power below HAT	2nd Option: FSC: F FSC Wood X Non-FSC Wood	3rd Option: Laminate: See page 18 for finishes.	4th Option: Edge: See page 18 for finishes.	5th Option: Grain: VLG Horizontal grain or Solid only VST Vertical Grain (available only for single panels 54"W or less)	6th Option: Glide: G
--	--	---	---	---	---	---

Example: GSYS5024G.MDWPH.X.LDW1.DW.VLG.G

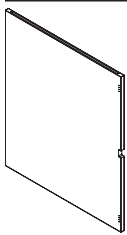

Description	Model	L1 List Price	L2 List Price	L3 List Price
50"H Fit Panels with Glass				
42"W	GSYS5042G (shown)	\$ 1390	\$ 1449	\$ 1508
48"W	GSYS5048G	\$ 1501	\$ 1565	\$ 1628
54"W	GSYS5054G	\$ 1586	\$ 1653	\$ 1719

How to specify — Select the Model Number from above. G	1st Option: Panel and Power Type: MDWPH Mid wing, no power below WS MDWPH Mid Wing no power below HAT LPEPN Left Hand Split End no power RPEPN Right Hand Split End no power	2nd Option: FSC: F FSC Wood X Non-FSC Wood	3rd Option: Laminate: See page 18 for finishes.	4th Option: Edge: See page 18 for finishes.	5th Option: Grain: VLG Horizontal grain or Solid only VST Vertical Grain (available only for single panels 54"W or less)	6th Option: Glide: G
--	---	---	---	---	---	---

Example: GSYS5042G.LPEPN.X.LDW1.DW.VLG.G

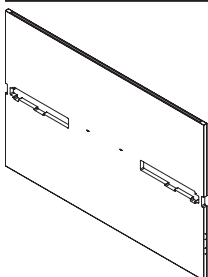

Description	Model	L1 List Price	L2 List Price	L3 List Price
50"H Fit Panels with Glass				
60"W	GSYS5060G	\$ 1660	\$ 1731	\$ 1801
66"W	GSYS5066G	\$ 1729	\$ 1803	\$ 1875
72"W	GSYS5072G (shown)	\$ 1811	\$ 1889	\$ 1964
78"W	GSYS5078G	\$ 2074	\$ 2161	\$ 2249
84"W	GSYS5084G	\$ 2361	\$ 2460	\$ 2559

How to specify — Select the Model Number from above. G	1st Option: Panel and Power Type: See page 23-24 for options.	2nd Option: FSC: F FSC Wood X Non-FSC Wood	3rd Option: Laminate: See page 18 for finishes.	4th Option: Edge: See page 18 for finishes.	5th Option: Grain: VLG Horizontal grain or Solid only	6th Option: Glide: G
--	---	---	---	---	--	---

Example: GSYS5072G.MSPSH.X.LDW1.DW.VLG.G

Panels

57½"H Application for Use with Glass

For Fit Glass see page 44.
For Fit Panel connectors see pages 47-48.

GSA SIN Pending



Description	Model	L1 List Price	L2 List Price	L3 List Price
57½"H Fit Panels with Glass				
18"W	GSYS5718G	\$ 1140	\$ 1189	\$ 1236
24"W	GSYS5724G (shown)	\$ 1197	\$ 1249	\$ 1298
30"W	GSYS5730G	\$ 1331	\$ 1388	\$ 1443
36"W	GSYS5736G	\$ 1426	\$ 1486	\$ 1546

How to specify — Select the Model Number from above.	<i>1st Option:</i> Panel and Power Type: MDWPW Mid wing, no power below WS MDWPH Mid Wing no power below HAT	<i>2nd Option:</i> FSC: F FSC Wood X Non-FSC Wood	<i>3rd Option:</i> Laminate: See page 18 for finishes.	<i>4th Option:</i> Edge: See page 18 for finishes.	<i>5th Option:</i> Grain: VLG Horizontal grain or Solid only VST Vertical Grain (available only for single panels 54"W or less)	<i>6th Option:</i> Glide:
	G V . G					

Example: GSYS5724G.MDWPH.X.LDW1.DW.VLG.G

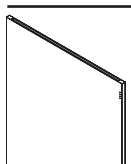

Description	Model	L1 List Price	L2 List Price	L3 List Price
57½"H Fit Panels with Glass				
42"W	GSYS5742G (shown)	\$ 1544	\$ 1610	\$ 1674
48"W	GSYS5748G	\$ 1655	\$ 1726	\$ 1796
54"W	GSYS5754G	\$ 1739	\$ 1813	\$ 1886

How to specify — Select the Model Number from above.	<i>1st Option:</i> Panel and Power Type: MDWPW Mid wing, no power below WS MDWPH Mid Wing no power below HAT LPEPN Left Hand Split End no power RPEPN Right Hand Split End no power	<i>2nd Option:</i> FSC: F FSC Wood X Non-FSC Wood	<i>3rd Option:</i> Laminate: See page 18 for finishes.	<i>4th Option:</i> Edge: See page 18 for finishes.	<i>5th Option:</i> Grain: VLG Horizontal grain or Solid only VST Vertical Grain (available only for single panels 54"W or less)	<i>6th Option:</i> Glide:
	G V . G					

Example: GSYS5742G.LPEPN.X.LDW1.DW.VLG.G

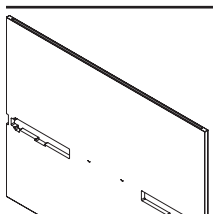

Description	Model	L1 List Price	L2 List Price	L3 List Price
57½"H Fit Panels with Glass				
60"W	GSYS5760G	\$ 1812	\$ 1890	\$ 1965
66"W	GSYS5766G	\$ 1883	\$ 1963	\$ 2042
72"W	GSYS5772G (shown)	\$ 1966	\$ 2049	\$ 2132
78"W	GSYS5778G	\$ 2226	\$ 2320	\$ 2413
84"W	GSYS5784G	\$ 2515	\$ 2622	\$ 2727

How to specify — Select the Model Number from above.	<i>1st Option:</i> Panel and Power Type: See page 23-24 for options.	<i>2nd Option:</i> FSC: F FSC Wood X Non-FSC Wood	<i>3rd Option:</i> Laminate: See page 18 for finishes.	<i>4th Option:</i> Edge: See page 18 for finishes.	<i>5th Option:</i> Grain: VLG Horizontal grain or Solid only	<i>6th Option:</i> Glide:
	G V L G . G					

Example: GSYS5772G.MSPSH.X.LDW1.DW.VLG.G

FIT

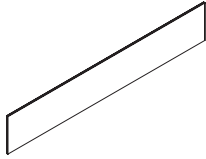

Description	Model	List Price		
		Clear Glass	Frosted Glass	Smoked Glass
7½"H Fit Glass				
15"W	G40715GS	\$ 212	\$ 233	\$ 240
18"W	G40718GS	\$ 218	\$ 240	\$ 247
21"W	G40721GS	\$ 222	\$ 244	\$ 252
24"W	G40724GS	\$ 226	\$ 249	\$ 256
27"W	G40727GS	\$ 246	\$ 270	\$ 278
30"W	G40730GS	\$ 263	\$ 290	\$ 297
33"W	G40733GS	\$ 289	\$ 318	\$ 327
36"W	G40736GS	\$ 325	\$ 357	\$ 368
39"W	G40739GS	\$ 352	\$ 386	\$ 399
42"W	G40742GS	\$ 394	\$ 434	\$ 446
45"W	G40745GS	\$ 428	\$ 471	\$ 484
48"W	G40748GS	\$ 465	\$ 511	\$ 525
51"W	G40751GS	\$ 475	\$ 522	\$ 537
54"W	G40754GS	\$ 514	\$ 564	\$ 581
57"W	G40757GS	\$ 569	\$ 625	\$ 643
60"W	G40760GS	\$ 667	\$ 732	\$ 754
63"W	G40763GS	\$ 776	\$ 853	\$ 877
66"W	G40766GS	\$ 839	\$ 921	\$ 948
69"W	G40769GS	\$ 918	\$ 1008	\$ 1037
72"W	G40772GS	\$ 982	\$ 1078	\$ 1110
75"W	G40775GS	\$ 1050	\$ 1152	\$ 1186
78"W	G40778GS	\$ 1156	\$ 1268	\$ 1306
81"W	G40781GS	\$ 1215	\$ 1334	\$ 1372
84"W	G40784GS	\$ 1239	\$ 1367	\$ 1408

FIT

<p><i>How to specify —</i> Select the Model Number from above.</p>	<p><i>1st Option:</i> Glass: LC Clear Glass LF Frosted Glass GSM1 Smoked Glass</p>
<p>G 4 0 7 .</p>	<p> </p>

Examples: G40715GS.LC G40739GS.GSM1

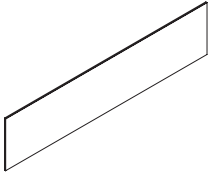

Description	Model	List Price		
		Clear Glass	Frosted Glass	Smoked Glass
13"H Fit Glass				
24"W	G41324GS	\$ 515	\$ 572	\$ 590
27"W	G41327GS	\$ 562	\$ 623	\$ 644
30"W	G41330GS	\$ 604	\$ 670	\$ 691
33"W	G41333GS	\$ 635	\$ 705	\$ 728
36"W	G41336GS	\$ 673	\$ 747	\$ 770
39"W	G41339GS	\$ 726	\$ 806	\$ 832
42"W	G41342GS	\$ 750	\$ 832	\$ 859
45"W	G41345GS	\$ 766	\$ 850	\$ 877
48"W	G41348GS	\$ 791	\$ 877	\$ 906
51"W	G41351GS	\$ 804	\$ 891	\$ 921
54"W	G41354GS	\$ 861	\$ 955	\$ 985
57"W	G41357GS	\$ 880	\$ 976	\$ 1008
60"W	G41360GS	\$ 905	\$ 1003	\$ 1036
63"W	G41363GS	\$ 970	\$ 1076	\$ 1111
66"W	G41366GS	\$ 1052	\$ 1167	\$ 1205
69"W	G41369GS	\$ 1113	\$ 1234	\$ 1274
72"W	G41372GS	\$ 1193	\$ 1323	\$ 1366
75"W	G41375GS	\$ 1281	\$ 1421	\$ 1466
78"W	G41378GS	\$ 1363	\$ 1511	\$ 1560
81"W	G41381GS	\$ 1438	\$ 1594	\$ 1646
84"W	G41384GS	\$ 1483	\$ 1650	\$ 1705

FT

<p><i>How to specify —</i> Select the Model Number from above.</p>	<p><i>1st Option:</i> Glass: LC Clear Glass LF Frosted Glass GSM1 Smoked Glass</p>
<p>G 4 1 3 .</p>	<p> </p>

Examples: G41324GS.LC G41339GS.GSM1

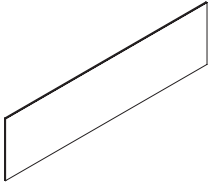

Description	Model	List Price		
		Clear Glass	Frosted Glass	Smoked Glass
15"H Fit Glass				
15"W	G41515GS	\$ 538	\$ 597	\$ 617
18"W	G41518GS	\$ 562	\$ 623	\$ 644
21"W	G41521GS	\$ 588	\$ 653	\$ 673
24"W	G41524GS	\$ 618	\$ 685	\$ 708
27"W	G41527GS	\$ 638	\$ 708	\$ 731
30"W	G41530GS	\$ 664	\$ 737	\$ 760
33"W	G41533GS	\$ 697	\$ 774	\$ 798
36"W	G41536GS	\$ 759	\$ 842	\$ 869
39"W	G41539GS	\$ 794	\$ 880	\$ 910
42"W	G41542GS	\$ 814	\$ 903	\$ 932
45"W	G41545GS	\$ 828	\$ 919	\$ 948
48"W	G41548GS	\$ 848	\$ 941	\$ 971
51"W	G41551GS	\$ 867	\$ 961	\$ 992
54"W	G41554GS	\$ 922	\$ 1023	\$ 1055
57"W	G41557GS	\$ 935	\$ 1037	\$ 1070
60"W	G41560GS	\$ 943	\$ 1046	\$ 1079
63"W	G41563GS	\$ 1000	\$ 1109	\$ 1145
66"W	G41566GS	\$ 1083	\$ 1201	\$ 1240
69"W	G41569GS	\$ 1139	\$ 1263	\$ 1304
72"W	G41572GS	\$ 1218	\$ 1350	\$ 1395
75"W	G41575GS	\$ 1315	\$ 1458	\$ 1506
78"W	G41578GS	\$ 1386	\$ 1536	\$ 1585
81"W	G41581GS	\$ 1467	\$ 1626	\$ 1679
84"W	G41584GS	\$ 1516	\$ 1686	\$ 1743

FIT

<p><i>How to specify —</i> Select the Model Number from above.</p>	<p><i>1st Option:</i> Glass: LC Clear Glass LF Frosted Glass GSM1 Smoked Glass</p>
<p>G 4 1 5 .</p>	<p> </p>

Examples: G41515GS.LC G41539GS.GSM1

For specification information see pages 21-51.

GSA SIN Pending

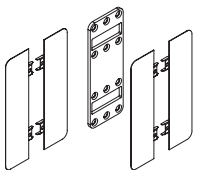

GPLTBK GSYSCONSE

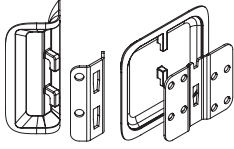

GSYSCONL GSYSCONS

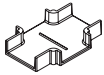

GSYSTP

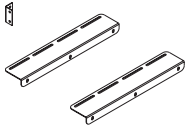

Description	Model	P1 List Price	P2 List Price	P3 List Price
Panel Connectors				
Single End Panel Connector	GPLTBK (shown)	\$ 102	\$ 102	\$ 102
Split Panel Connector	GSYSCONSE (shown)	\$ 90	\$ 95	\$ 99
Corner Panel Connector, 2-Pack	GSYSCONL (shown)	\$ 121	\$ 128	\$ 132
Straight In-Line Panel Connector	GSYSCONS (shown)	\$ 181	\$ 190	\$ 198
Installation Template	GSYSTP (shown)	\$ 61		

Worksurface Mounting Bracket Kit

Worksurface Mounting Bracket	GWSBK	\$ 80		
------------------------------	-------	-------	--	--

Note: Ships with 2 brackets.

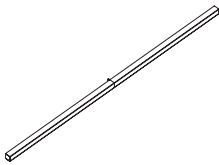

Fit Panel Stiffeners

Stiffener for 75"/78"W Panels	GSTFN7578	\$ 181	\$ 196	\$ 215
Stiffener for 81"/85"W Panels	GSTFN8184	\$ 202	\$ 219	\$ 242

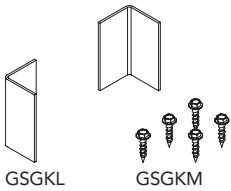

GSGKL

GSGKM

Storage Ganging Kits

Laminate Storage Ganging Kit (no color option)	GSGKL (shown)	\$ 80		
Metal Storage Ganging Kit (no color option)	GSGKM (shown)	\$ 19		



Fit Wall Start

30"H Wall Start	GWS30	\$ 124	\$ 131	\$ 135
35"H Wall Start	GWS35	\$ 142	\$ 149	\$ 155
42"H Wall Start	GWS42	\$ 154	\$ 162	\$ 167
50"H Wall Start	GWS50	\$ 177	\$ 186	\$ 193
57½"H Wall Start	GWS57	\$ 190	\$ 199	\$ 207

How to specify —

Select the Model Number from above.

1st Option:

Paint:

P1 P2 P3

See page 18 for finishes.

G | | | | | | | | | | . | | | | |

Examples: GWS57.PJW

For specification information see pages 21-51.

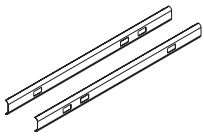

GSYSR60DS

Description	Model	P1 List Price	P2 List Price	P3 List Price
Rails				
Spine Rail 60"W Double Sided	GSYSR60DS (shown)	\$ 383	\$ 400	\$ 416
Spine Rail 66"W Double Sided	GSYSR66DS	\$ 401	\$ 419	\$ 435
Spine Rail 72"W Double Sided	GSYSR72DS	\$ 430	\$ 449	\$ 467
Spine Rail 78"W Double Sided	GSYSR78DS	\$ 461	\$ 481	\$ 501
Spine Rail 84"W Double Sided	GSYSR84DS	\$ 490	\$ 511	\$ 532

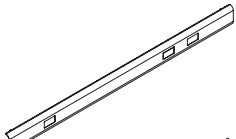

GSYSR60SS

Spine Rail 60"W Single Sided	GSYSR60SS (shown)	\$ 219	\$ 229	\$ 238
Spine Rail 66"W Single Sided	GSYSR66SS	\$ 230	\$ 241	\$ 250
Spine Rail 72"W Single Sided	GSYSR72SS	\$ 247	\$ 258	\$ 268
Spine Rail 78"W Single Sided	GSYSR78SS	\$ 264	\$ 276	\$ 287
Spine Rail 84"W Single Sided	GSYSR84SS	\$ 279	\$ 291	\$ 303

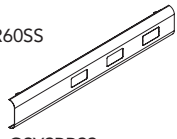

GSYSRRSS

Return Rail Double Sided	GSYSRRDS	\$ 456	\$ 476	\$ 496
Return Rail Single Sided	GSYSRRSS (shown)	\$ 227	\$ 237	\$ 247

Rail Connectors

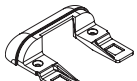

GSYSREC

Rail End Cap	GSYSREC (shown)	\$ 90	\$ 95	\$ 99
Rail Straight Inline Connector	GSYSRSL (shown)	\$ 121	\$ 128	\$ 132
Rail Straight Corner Connector	GSYSRSC (shown)	\$ 90	\$ 95	\$ 99
Rail "L" Connector	GSYSRL (shown)	\$ 90	\$ 95	\$ 99
Rail Infeed Straight Corner Connector	GSYSRPS (shown)	\$ 121	\$ 128	\$ 132
Rail Infeed "L" Connector	GSYSRPL (shown)	\$ 121	\$ 128	\$ 132
Rail Infeed Connector Shroud BW	GSYSRBW (shown)	\$ 188	\$ 197	\$ 205
Rail Infeed Connector Shroud BH	GSYSRBH	\$ 188	\$ 197	\$ 205
Rail Hardwire Infeed Shroud BW	GSYSHWBW (shown)	\$ 188	\$ 197	\$ 205
Rail Hardwire Infeed Shroud BH	GSYSHWBH	\$ 188	\$ 197	\$ 205

Note: Rail Hardwire Infeed Shroud BW and BH models GSYSHWBW and GSYSHWBH must be used with Hardwire Infeed Housing model U8SBKCH (ordered separately).

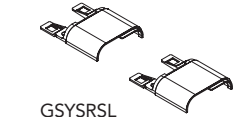

GSYSRSL

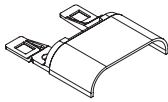

GSYSRSC

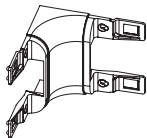

GSYSRL

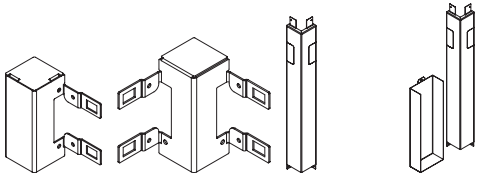

GSYSRPS

GSYSRPL

GSYSRBW

GSYSRBH

GSYSHWBW

How to specify —

Select the Model Number from above.

1st Option:

Paint:

P1 P2 P3

See page 18 for finishes.

G

Examples: GSYRRDS.PJW

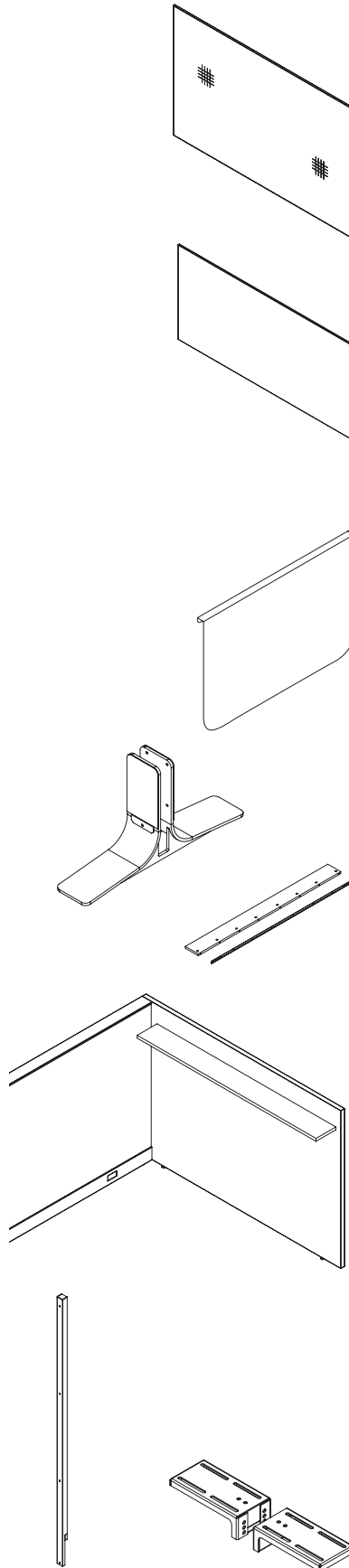

Tackboards (page 52)

- Provides tackable surface.
- Comes with steel-painted trim.
- Available in the following heights: 15", 22½"
- Available in the following *widths: 24", 30", 36", 42", 48", 54", 60"
*Nominal widths, true width is undersized by ½"
- Depth of .45"
- Mounts directly to Fit Panel. Mounting hardware included. Will deface the panel.

Magnet or Marker Boards (page 52)

- Provides writable and magnetic surface when painted in marker board paint.
- Provides magnetic surface, NON-writable, when painted in other Allsteel paint colors.
- Available in the following heights: 15", 22½"
- Available in the following *widths: 24", 30", 36", 42", 48", 54", 60"
*Nominal widths, true width is undersized by ½"
- Depth of .45"
- Mounts directly to Fit Panel. Mounting hardware included. Will deface the panel.

Hanging Magnet or Marker Boards (page 52)

- Hangs over Fit panel or sits on top of worksurface.
- Provides writable and magnetic surface when painted in marker board paint.
- Provides magnetic surface, NON-writable, when painted in other Allsteel paint colors.
- Cannot be installed back-to-back when hanging in the same location.
- Available in 30"W and in two heights: 20"H and 26"H.

Fit Panel Foot (page 52)

- Single foot provides rigidity to large wing panel.
- Available in any textured Allsteel paint.
- Foot extends 9" from either side of the panel.

Floating Laminate Shelves (page 53)

- 6" depth.
- ¾" thickness.
- Constructed of HPL laminate with 0.8mm ABS edgebanding.
- Available in solid or horizontal woodgrain laminate.
- Available with contrasting or matching edge.
- Widths available every 6" from 12" to 78"W.
- Widths from 54" to 78" satisfy a stiffener requirement and are meant to be mounted to a panel that is 6" wider than the shelf. (e.g., 84"W panel would accept a 78"W stiffener shelf.)
- Shelves narrower than 54"W do not act as a stiffener.
- Shelf stiffeners must be installed above the power rail to function as a stiffener.

Wall Start (page 47)

- Wall Starts are 1½" by 1½" rectangular mounting posts that are meant to affix a Fit panel to a permanent building wall.
- Wall starts add 1½" to panel run.
- Attachment hardware not included.
- Must be specified at the same height as the connecting panel.

Countertop Brackets (page 54)

- Includes attachment hardware.
- Countertops are flush with the top of the panel and can be flush with the ends of the panel or shorter than the panel width.
- For straight countertops, two countertop brackets must be ordered.
- For corner countertops, three countertop brackets must be ordered.
- Will deface the panel.

Accessory Rail and Paper Management (page 53)

- Accessory Rail provides mounting for paper management accessories, listed below.
- Rail is 2.6"H and is available in the following widths: 12", 18", 24", 30", 36".
- Rails can be installed in any location on the Fit panel and can be placed in-line to span panel length.
- Rail height when installed cannot exceed the height of the panel.
- Rail and accessories can be painted any standard Allsteel paint color.
- Mounts directly to the Fit panel, attachment hardware included.
- Extensions accessories are NOT compatible with the accessory rail.
- These accessories are compatible with tool tiles.
- Includes a rail cover to hide hardware and provide magnetic surface.
- Compatible Rail Accessories:
 - Coat Hook (Rail-based, a mounted version is also available to attach directly to the panel)
 - Rail Based dimensions: 4" x 3" x 1¼"
 - Mounted dimensions: 4" x 3" x 1½"
 - Angle File (Triple, Dual, and Single heights)
 - Depth of 2"
 - Heights: Triple = 15½", Dual = 12½", Single = 9½"
 - Paper Tray (Triple, Dual, and Single heights)
 - Depth of 10"
 - Heights: Triple = 9½", Dual = 6½", Single = 3½"
 - Personal Shelf
 - 9½" x 24" x 10½"
 - Binder Shelf
 - 12½" x 12" x 11½"

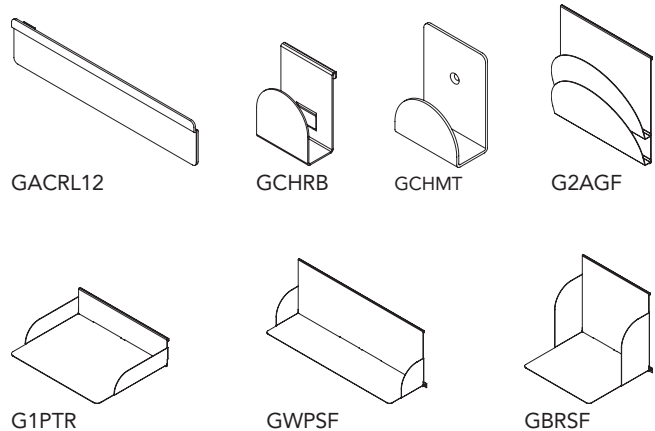

Height-Adjustable Table Tie-In Brackets (page 53)

- Improves panel rigidity. Does not function as a panel stability solution.
- AGBKT to be specified for connection to a T-leg HAT.
- AGBKC to be specified for connection to a C-leg HAT.
- Reusable mounting template is required and must be ordered separately (AGBKTMP).
- Brackets telescope to account for 24" and 30" worksurface depths and screen attachments.
- A6 C-legs with a 30"D worksurface and a screen must be specified with T-leg brackets.
- NOTE: Wire chain cannot be installed on the same leg as the HAT tie-in bracket.

Max Height (with Glass): 65"H
Max Width: 84"W; No top size restrictions

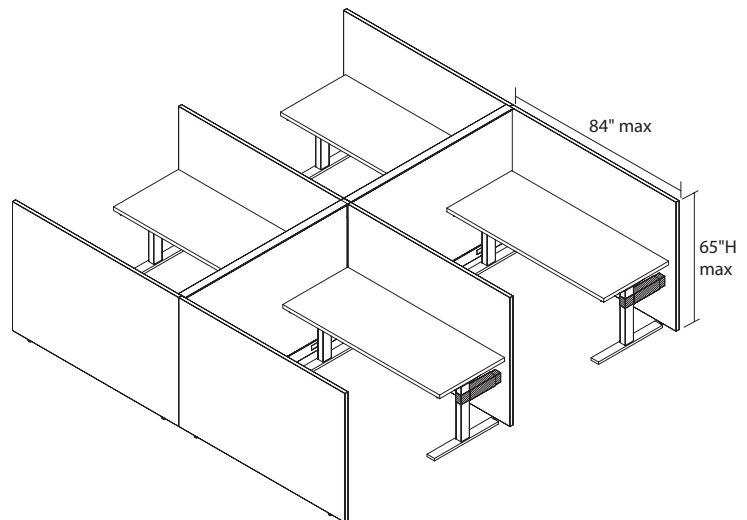

Dual-Sided Panel Bench

- Can be created using HAT brackets or Fit Panel Feet. Cannot be single-sided. No maximum run length.

Height-Adjustable Table Tie-In Brackets (page 53)

- Max height (with Glass): 65"H
- Max Width: 84"W

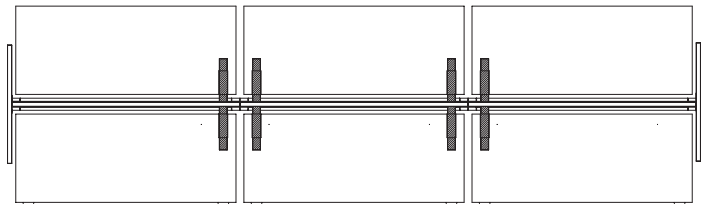
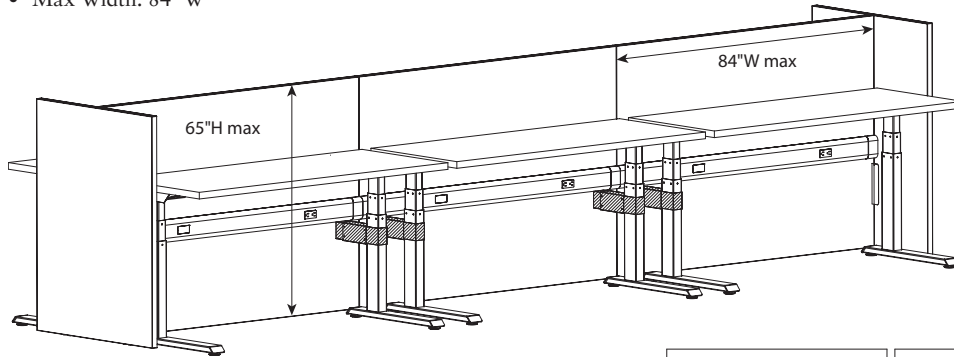

Fit Panel Feet (page 52)

- Max height (with Glass): 65"H
- Max Width: 84"W

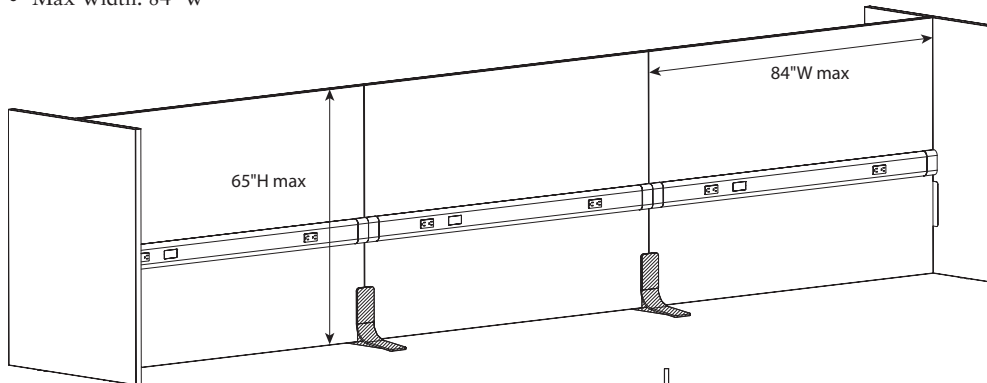

For specification information see pages 21-51.

GSA SIN Pending

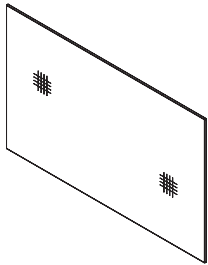

Description	Model	P1 List Price	P2 List Price	P3 List Price	P6 List Price
Tackboards					
Tackboard 15"H x 24"W	GTB1524	\$ 351	\$ 367	\$ 381	N/A
Tackboard 15"H x 30"W	GTB1530	\$ 382	\$ 399	\$ 414	N/A
Tackboard 15"H x 36"W	GTB1536	\$ 423	\$ 442	\$ 460	N/A
Tackboard 15"H x 42"W	GTB1542	\$ 440	\$ 459	\$ 478	N/A
Tackboard 15"H x 48"W	GTB1548	\$ 450	\$ 470	\$ 490	N/A
Tackboard 15"H x 54"W	GTB1554	\$ 471	\$ 492	\$ 512	N/A
Tackboard 15"H x 60"W	GTB1560	\$ 478	\$ 499	\$ 520	N/A
Tackboard 22.5"H x 24"W	GTB2224	\$ 395	\$ 413	\$ 428	N/A
Tackboard 22.5"H x 30"W	GTB2230	\$ 429	\$ 448	\$ 466	N/A
Tackboard 22.5"H x 36"W	GTB2236 (shown)	\$ 468	\$ 488	\$ 509	N/A
Tackboard 22.5"H x 42"W	GTB2242	\$ 478	\$ 499	\$ 520	N/A
Tackboard 22.5"H x 48"W	GTB2248	\$ 515	\$ 537	\$ 559	N/A
Tackboard 22.5"H x 54"W	GTB2254	\$ 541	\$ 564	\$ 587	N/A
Tackboard 22.5"H x 60"W	GTB2260	\$ 556	\$ 580	\$ 604	N/A

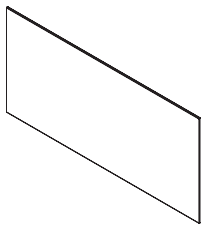

Magnet/Marker Boards					
Magnet/Marker Board 15"H x 24"W	GMB1524	\$ 464	\$ 484	\$ 505	\$ 562
Magnet/Marker Board 15"H x 30"W	GMB1530	\$ 501	\$ 523	\$ 544	\$ 607
Magnet/Marker Board 15"H x 36"W	GMB1536	\$ 533	\$ 556	\$ 579	\$ 646
Magnet/Marker Board 15"H x 42"W	GMB1542	\$ 560	\$ 584	\$ 608	\$ 678
Magnet/Marker Board 15"H x 48"W	GMB1548	\$ 587	\$ 612	\$ 637	\$ 710
Magnet/Marker Board 15"H x 54"W	GMB1554	\$ 604	\$ 631	\$ 656	\$ 732
Magnet/Marker Board 15"H x 60"W	GMB1560	\$ 638	\$ 666	\$ 693	\$ 772
Magnet/Marker Board 22.5"H x 24"W	GMB2224	\$ 572	\$ 596	\$ 621	\$ 693
Magnet/Marker Board 22.5"H x 30"W	GMB2230	\$ 601	\$ 626	\$ 653	\$ 728
Magnet/Marker Board 22.5"H x 36"W	GMB2236	\$ 626	\$ 653	\$ 680	\$ 758
Magnet/Marker Board 22.5"H x 42"W	GMB2242	\$ 656	\$ 684	\$ 712	\$ 793
Magnet/Marker Board 22.5"H x 48"W	GMB2248 (shown)	\$ 688	\$ 718	\$ 746	\$ 833
Magnet/Marker Board 22.5"H x 54"W	GMB2254	\$ 709	\$ 739	\$ 769	\$ 858
Magnet/Marker Board 22.5"H x 60"W	GMB2260	\$ 734	\$ 765	\$ 796	\$ 889

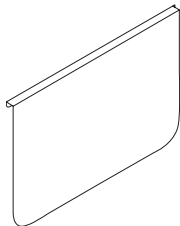

Hanging Magnet/Marker Boards & Blotter					
Hanging Magnet/Marker Board or Blotter 20"H x 30"W	GHMB2030 (shown)	\$ 365	\$ 382	\$ 396	\$ 443
Hanging Magnet/Marker Board or Blotter 26"H x 30"W	GHMB2630	\$ 507	\$ 529	\$ 551	\$ 615

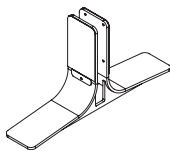

Support Foot					
Fit Support Foot	GFT1	\$ 347	\$ 363	\$ 377	

Note: Available in textured paint only

How to specify —
Select the
Model Number
from above.

1st Option:

Paint:

P1 P2 P3

See page 18 for finishes.

2nd Option:

Fabric

(if applicable):

See page 18 for finishes.

G | | | | | | | | | | .

| | | | | .

| | | | | | | | | |

Examples: GHMB2030.MKP

Panels

Fit Accessories

For specification information see pages 21-51.

GSA SIN Pending

Description	Model	L1 List Price	L2 List Price	L3 List Price
Laminate Floating Shelves				
12"W Floating Shelf	GSTF12	\$ 271	\$ 283	\$ 294
18"W Floating Shelf	GSTF18	\$ 302	\$ 315	\$ 329
24"W Floating Shelf	GSTF24	\$ 332	\$ 347	\$ 361
30"W Floating Shelf	GSTF30	\$ 362	\$ 379	\$ 393
36"W Floating Shelf	GSTF36	\$ 393	\$ 411	\$ 426
42"W Floating Shelf	GSTF42	\$ 423	\$ 442	\$ 460
48"W Floating Shelf	GSTF48	\$ 453	\$ 473	\$ 493
54"W Floating Stiffener Shelf	GSTF54	\$ 483	\$ 504	\$ 525
60"W Floating Stiffener Shelf	GSTF60	\$ 513	\$ 535	\$ 557
66"W Floating Stiffener Shelf	GSTF66 (shown)	\$ 543	\$ 566	\$ 590
72"W Floating Stiffener Shelf	GSTF72	\$ 572	\$ 596	\$ 621
78"W Floating Stiffener Shelf	GSTF78	\$ 604	\$ 631	\$ 656

Accessory Rail & Paper Management				
Gallery Panel 12"W Accessory Rail	GACRL12 (shown)	\$ 238	\$ 249	\$ 259
Gallery Panel 18"W Accessory Rail	GACRL18	\$ 255	\$ 267	\$ 277
Gallery Panel 24"W Accessory Rail	GACRL24	\$ 257	\$ 269	\$ 279
Gallery Panel 30"W Accessory Rail	GACRL30	\$ 271	\$ 283	\$ 294
Gallery Panel 36"W Accessory Rail	GACRL36	\$ 286	\$ 299	\$ 310
Triple Angle File	G3AGF	\$ 226	\$ 236	\$ 246
Double Angle File	G2AGF (shown)	\$ 190	\$ 199	\$ 207
Single Angle File	G1AGF	\$ 155	\$ 163	\$ 170
Triple Paper Tray	G3PTR	\$ 226	\$ 236	\$ 246
Double Paper Tray	G2PTR	\$ 190	\$ 199	\$ 207
Single Paper Tray	G1PTR (shown)	\$ 155	\$ 163	\$ 170
Personal Shelf	GWPSF (shown)	\$ 190	\$ 199	\$ 207
Binder Shelf	GBRSF (shown)	\$ 190	\$ 199	\$ 207
Coat Hook Rail-Based	GCHRB (shown)	\$ 77	\$ 82	\$ 85
Coat Hook Mounted	GCHMT	\$ 90	\$ 95	\$ 99

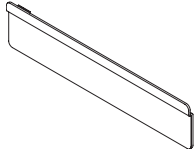
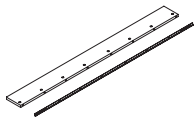

GACRL12

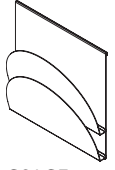

G2AGF

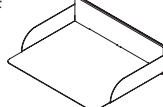

G1PTR

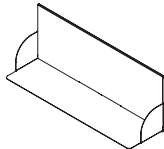

GWPSF

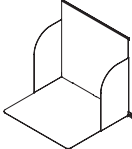

GBRSF

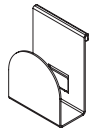

GCHRB

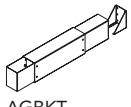

AGBKT

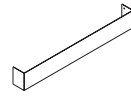

AGBKTMP

HAT Bracket				
HAT to Fit Panel Bracket T-Leg	AGBKT (shown)	\$ 258	\$ 280	\$ 308
HAT to Fit Panel Bracket C-Leg	AGBKC	\$ 258	\$ 280	\$ 308
HAT to Fit Panel Installation Template (Black only, code P)	AGBKTMP (shown)	\$ 63		

How to specify —
Select the Model Number from above.

1st Option:

Paint:

P1 P2 P3

See page 18 for finishes.

Examples: AGBKC.PJW

For specification information see pages 95-110.

Description	Laminate w/Flat Edge Model	Laminate w/Flat Edge		
		L1 List Price	L2 List Price	L3 List Price
Straight Countertops — must order 2 sets of brackets per surface				
24"W x 15"D	851524M	\$ 387	\$ 405	\$ 418
30"W x 15"D	851530M	\$ 429	\$ 448	\$ 462
36"W x 15"D	851536M	\$ 482	\$ 502	\$ 519
42"W x 15"D	851542M	\$ 499	\$ 519	\$ 537
48"W x 15"D	851548M	\$ 528	\$ 549	\$ 568
54"W x 15"D	851554M	\$ 598	\$ 621	\$ 641
60"W x 15"D	851560M	\$ 667	\$ 687	\$ 704
66"W x 15"D	851566M	\$ 691	\$ 720	\$ 739
72"W x 15"D	851572M	\$ 718	\$ 748	\$ 767

Corner Countertops 15"D at ends — must order 3 sets of brackets per surface				
24"W x 24"W	852424M	\$ 754	\$ 785	\$ 806
30"W x 30"W	853030M	\$ 877	\$ 911	\$ 936
36"W x 36"W	853636M	\$ 973	\$ 1010	\$ 1039
42"W x 42"W	854242M	\$ 1056	\$ 1096	\$ 1129

Countertop Bracket		Countertop Connector Bracket		
Countertop Connector Bracket	GCTKS	\$ 121	\$ 128	\$ 132

Note: Must order two brackets for straight countertop, three brackets for corner countertop.

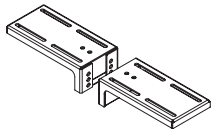
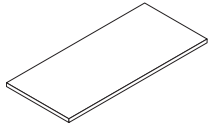

GCTKS



Flat Edge

<p>How to specify — Select the Model Number from above.</p>	<p>1st Option: Laminate: See page 18 for finishes.</p>	<p>2nd Option: Edge Trim Color: See page 18 for finishes.</p>
<input type="text"/>	<input type="text"/>	<input type="text"/>

Examples: 851524M.LT3B.EX

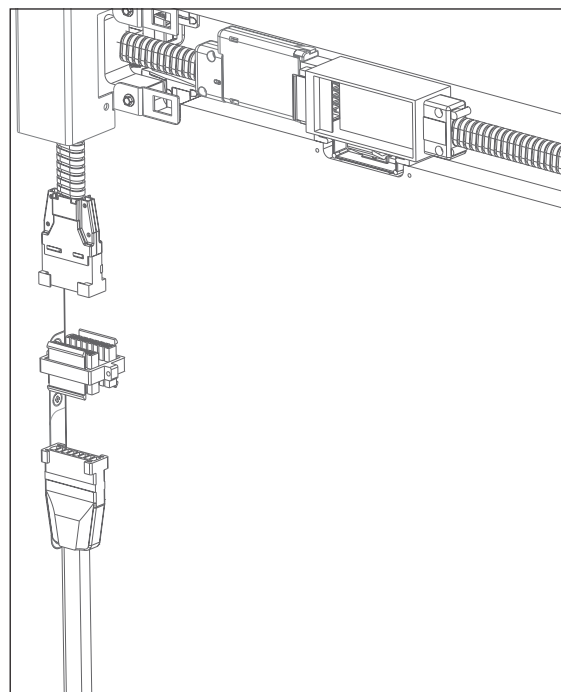
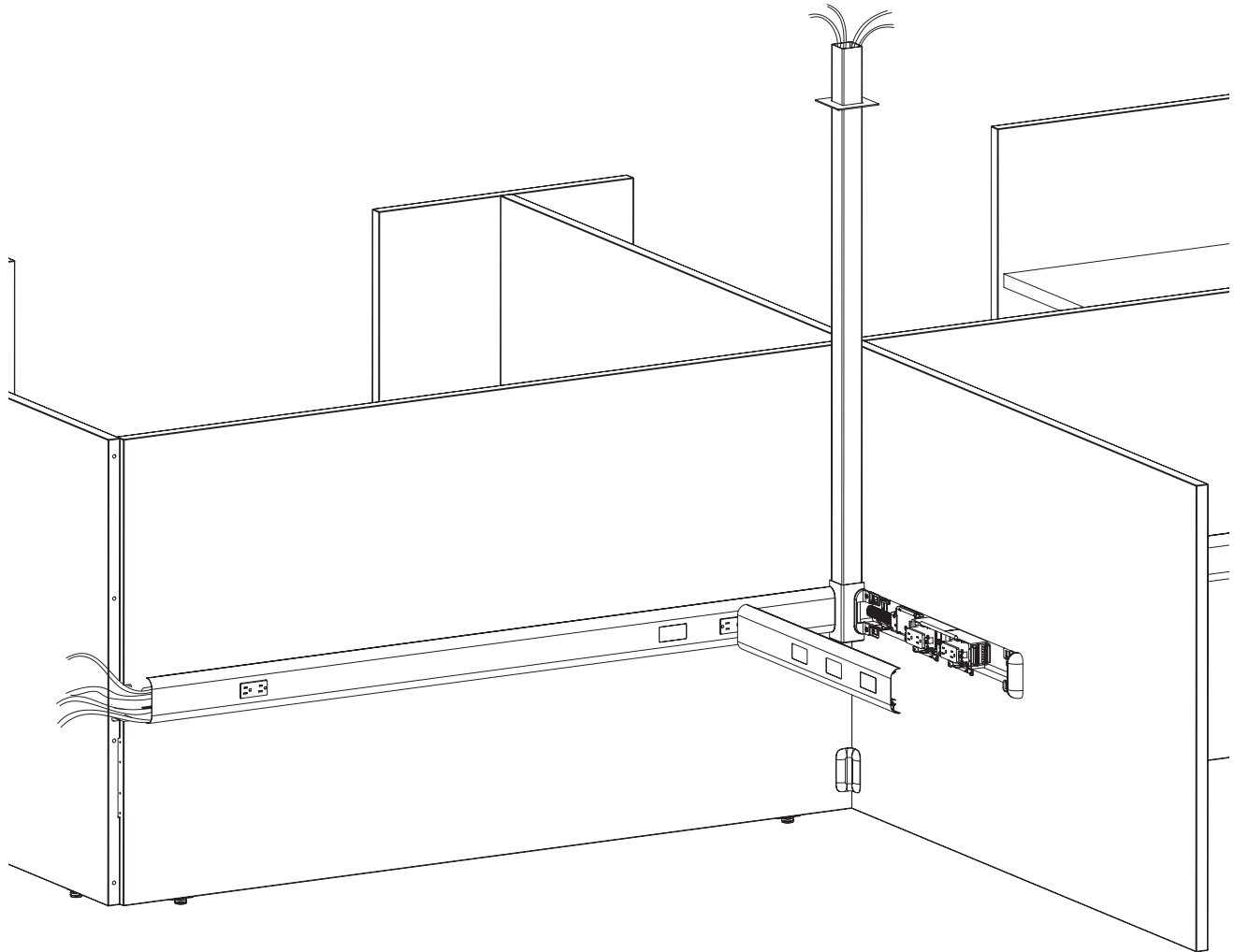

Floor infeed electrical connection



Electrical Systems

Fit Electrical Systems

Fit offers a choice of three electrical systems:

- Four-circuit, 3 + 1
- Four-circuit, 2 + 2
- Three-circuit, separate neutrals
- See pages 60-61 for a detailed explanation of each electrical system.
- All 3 systems utilize an 8-wire electrical system, rated at 20 amps per circuit (15 amps Canadian)
- Fit panels and electrical components are UL listed. Electrical components are also CSA certified.
- Installation and use of the electrical system, the number of receptacles used on a given circuit, and connections to the building power supply should be in compliance with all local and national electrical codes.

Caution: Electrical equipment cords or extension cords MUST NOT BE ROUTED through panels.

Hardwire Junction Box – New York Code (page 64)

- Hardwire (New York Code) junction box is used when local electrical codes require hardwire entry.
- Separate junction boxes must be specified for single- or dual-sided power.
- For use with hardwire power infeed shrouds, models GSYSHWBH & GSYSHWBW.
- Unit must connect to a power or pass-thru harness positioned in the rail of an adjacent panel.
- Customer to furnish all cabling and wiring from power entry to power source.
- Junction box can be positioned at any 90-degree panel connection with an adjacent rail.
- Must order housing model U8SBKCH for junction box.

Hardwire Wiring Harness – Chicago Code (page 65)

- The junction box must connect into power harness within rail through a hardwire power infeed shroud at a 90-degree panel connection with an adjacent rail.
- Hardwire receptacles connect into standard mounting locations within rail.
- Power entry can be routed from the ceiling, via a Fit power pole, or from the floor into a junction box model.
- For single-sided applications use junction box A871500. For double-sided application use junction box 877600. Must order junction box housing model U8SBKCH separately in both cases.

Electrical Infeeds

- Power infeed cables deliver power from building to panel's electrical system.
- Infeed cables are housed in conduit to separate electrical system from communication and data lines.
- Select quantity of base or ceiling infeed cables depending on individual power requirements.
- When using sealtight infeeds, an additional H-clip is needed to connect the infeed to the power harness, ordered separately.
- When bringing in an infeed from outside the station, adjust the leveling glides up to allow the infeed cable to fit under the panel.

Ceiling Power Infeed (page 64)

- Ceiling power infeed connects to a prewired electrical harness in the rail pathway, traverses through an adjacent panel, and terminates in the junction box at the top of the integrated power pole.
- Use power pole model GSYSP.
- Most codes allow flex cables to be exposed after installation. Verify code requirements before ordering for exposed application.

Integrated Power/Communication Pole (page 65)

- Integrated power pole accommodates ceiling power infeed and communication/data lines.
- Provide capacity for routing power infeed and cables to the power rail.
- Conduit of the infeed cables serves as the division of electrical and communication cabling.
- Installs into Below Worksurface or Below HAT rail heights in a 90-degree panel connection.
- Single cavity with removable cover.
- Height: 13", Outside Dimension: 2" square.
- When using a ceiling power infeed, consider that the infeed must connect into an electrical harness.
- To power the prewired electrical system, from a ceiling power source, a ceiling infeed cable must be purchased separately.

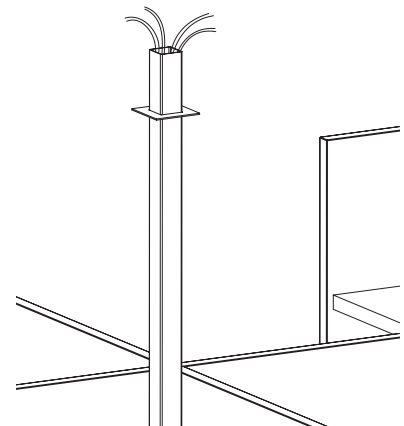
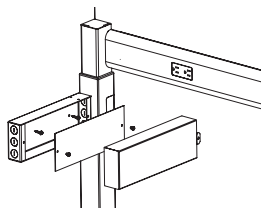
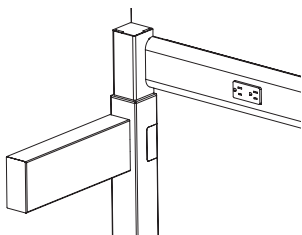

Power Harnesses and Pass-Thru Harnesses

Electrical power harnesses are used to distribute power in Fit panels. Harness power blocks snap directly onto brackets in base pathway. Power blocks on electrical power harness and pass-thru harness accept duplex receptacles.

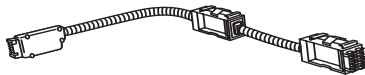
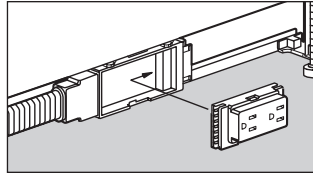

Electrical Power Harness

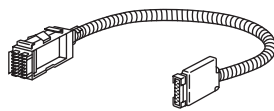

Electrical Pass-Thru Harness With Power Block

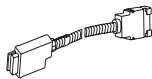

Electrical Pass-Thru Harness Without Power Block

Electrical Power Harnesses (page 63)

- Electrical power harnesses are used to distribute power in panels.
- Fit electrical can only be located at one location.
- Specify harness length to match panel width.
- Connectors at both ends of power harnesses allow power distribution in either direction.
- Harness power blocks snap directly onto brackets in the rail.

Electrical Pass-thru Harness With Power Block (page 63)

- Electrical pass-thru harnesses with power block have capacity to handle one duplex receptacle on each side of the panel when exposed.
- Specify harness length to match panel width.
- Power harnesses accept one duplex receptacle per panel side.

Electrical Pass-thru Harnesses Without Power Block (page 63)

- Specify harness length to match panel width.
- Electrical pass-thru cables distribute power through any panel(s) where receptacles are not required. Cable length cannot be stretched.

All electrical power harnesses and pass-thru harnesses will stretch 3/2", allowing them to span "T", "X", and "S" extended straight connections.

Note: "T" intersections require a minimum of one power harness and "X" intersections requires a minimum of two power harnesses.

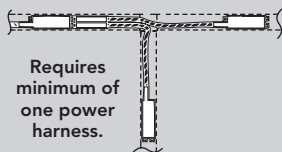

Requires minimum of one power harness.

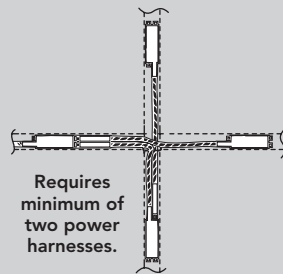

Requires minimum of two power harnesses.

Use of a ceiling infeed at this location requires an additional power harness.

Receptacles

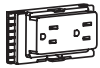

Duplex Receptacle

Receptacle Color Recommended to Coordinate with Paint Color

Paint Color	Receptacle Color
Designer White — PJW	Designer White — DW
Bungalow — P7C	Muslin — EU
Carob — P52	Black — E4
Champagne Metallic — PR5	Muslin — EU
Cinder — P7Q	Brownstone — EY
Fossil — P28	Flint — E9
Gunmetal Metallic — PR3	Brownstone — EY
Parchment — P93	Muslin — EU
Pebble — P8R	Loft — EV
Pewter — P8D	Flint — E9
Platinum Metallic — PR2	Loft — EV
Salt — P8C	Silver — ES
Titanium — P8T	Silver — ES

Duplex Receptacles (page 64)

- Duplex receptacles snap into power blocks of power harnesses or pass-through harnesses with blocks.
- Duplexes are available in multiple colors. See page 68 for finishes.
- Each receptacle is labeled to indicate which circuit it will be connected to: 1, 2, 3, or 4.
- Duplexes are model specific to support either 3+1 and 2+2 electrical infeed; or have an "A" suffix and are design to support a three-circuit separate neutral electrical infeed.

Single- vs Dual-Sided

- Different receptacles are required for single vs dual-sided power, see page 64 for models.

Data Components

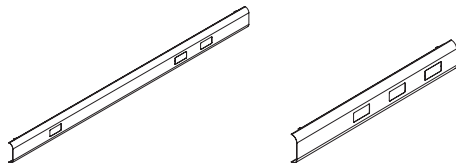
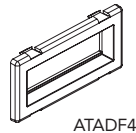
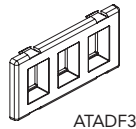
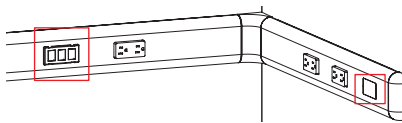

Data Faceplates (page 65)

- Fit not only provides space for voice and data cables, it also offers several means of mounting commercially available voice and data components.
- Commercially available modular data faceplates can be mounted in vacant rail receptacle openings.
- Due to rail depth, back-to-back data modules should not be used. Rail knockouts must be located on opposite sides in dual-sided applications.

Fit Rail Covers (page 48)

- Features additional knockout (offset) for improved utilization of power and data. Knockouts are 2.7"W and 1.344"H.
- Two power cutouts are available per powered panel for receptacle placement. Port covers are available (ordered separately) for unused receptacle locations.

Rail Port Cover (page 65)

- Offered in a 2- or 12-pack.
- Used to cover a port location in a rail when a receptacle is not needed.

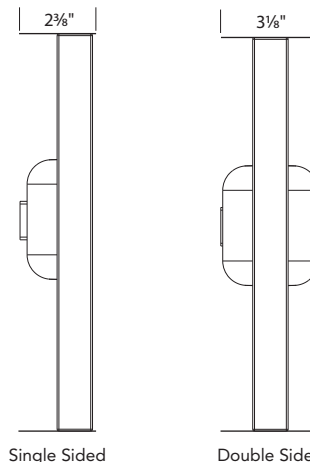

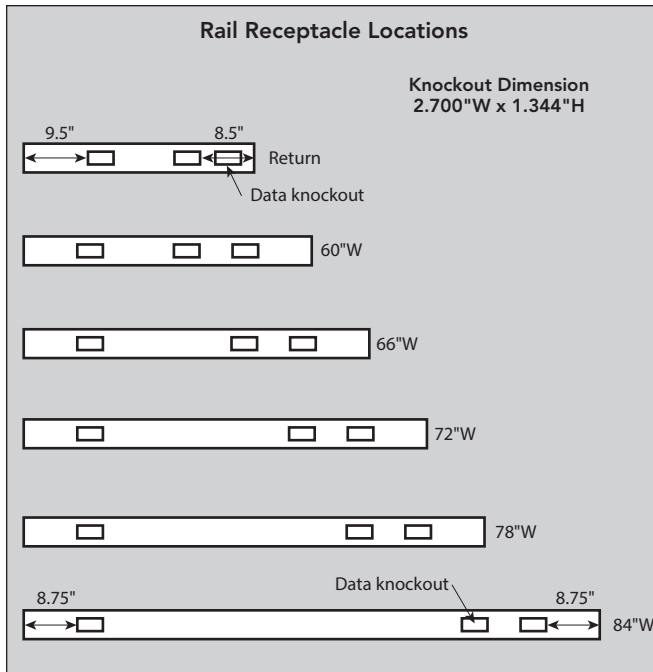

Circuit Usage

Strategy 1

Circuits to Equipment

Assign specific uses for each of the circuits:

- For example, in a four-circuit system:
 - Circuit 1 — Calculators, fans, etc.
 - Circuit 2 — Task lights (could be wired to wall switch)
 - Circuit 3 — CRT or flat screen monitors
 - Circuit 4 — CPUs

Strategy 2

Circuits to Workstations

Assign specific workstations to each of the three available circuits. Use circuit 4 for power-sensitive electronic equipment.

Rails are non-handed, so the data knockout may be installed on the left- or right-hand side of the panel. **NOTE:** Data may not be installed back-to-back in dual-sided applications.

Lay-in Cable Capacity

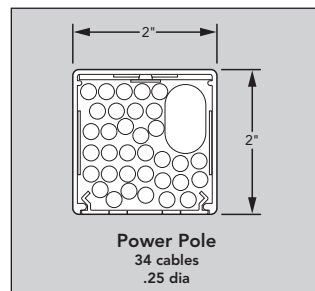
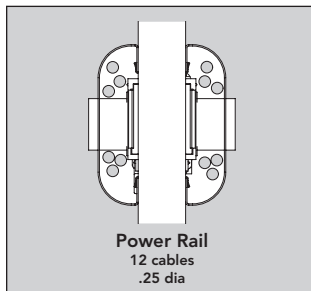

- The Fit power rail allows continuous voice and data cables to run through and between panels without interruption.
- The rail accepts up to 12 voice/data cables (1/4" dia) at 60% fill when electrical system shares the rail.
- Cable capacity of the Fit power pole is 3.3 sq. in. for a total capacity of 34 cables of 1/4" diameter.
- Cables can enter/exit rail through the ceiling power pole or the base infeed power pole.

Note: Cable quantities listed are at 60% fill ratio.

To Order:

- Determine which electrical system you will use after consulting your electrician and computer support personnel:
 - The four-circuit system (4-Hot/2-Neutral/2-Ground)
 - 3 + 1 option
 - 2 + 2 option
 - The three-circuit system (3-Hot/3-Neutral/2-Ground)
 - The eight-circuit system (back-to-back four-circuit systems)
- Determine location, quantity, and circuit of duplexes.
- Determine the appropriate choice and use of isolated, isolated/dedicated, and separate neutrals circuits.
- Specify appropriate power harnesses* and pass-thru cables.*
- Determine the location, quantity, and type of power infeed needed.

* Select power harness models (A8712XX), pass-thru cables (A8710XX), and pass-thru harness (A8711XX) with the last two digits corresponding with the panel width into which the component is to be positioned. The initial cable length can be stretched approximately 3" to transverse "T", "X", "L", and extended straight connectors.

Flexconnect™ Electrical System Options

The four-circuit, eight-wire electrical system is widely specified and trusted by hundreds of thousands of end-users. This proven system delivers four circuits for every power infeed in either a 3 + 1 or 2 + 2 configuration. The isolated/dedicated circuits are ideal for sensitive computing equipment, while the common circuits are suitable for faxes, copiers, task lights and other peripherals. Both the 3 + 1 and 2 + 2 systems use the same pre-wired components, making it easy to adjust as electrical needs change.

You can also choose a three-circuit, eight-wire system that has a dedicated neutral for every hot circuit. The three-circuit components have model numbers with an "A" suffix and appear in a gray box in this price.

All three systems utilize an eight-wire electrical system rated at 20 amps per circuit (15 amps Canadian). Fit panels and electrical components are UL listed and CSA certified.

Reference the Office Equipment Typical Load Values matrix on page 62.

Four-circuit, 3 + 1 Receptacle Option

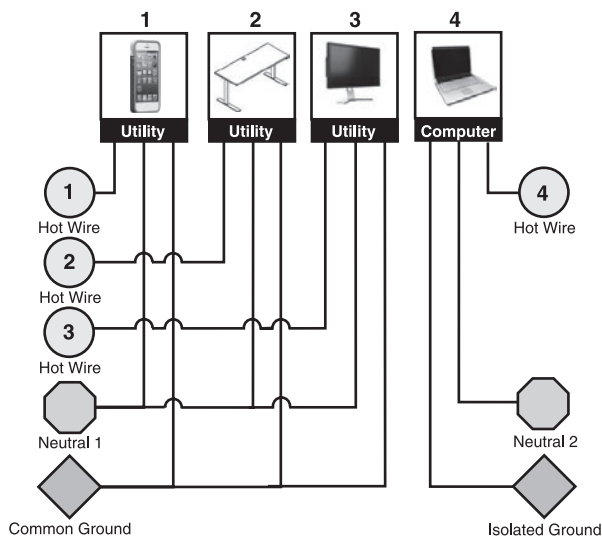

The 3 + 1 option is the electrical standard used on Allsteel systems for many years in most installations. This wiring option provides three utility circuits plus an isolated/dedicated circuit for more sensitive equipment. Circuit 2 (one of the 3 common circuits sharing a neutral wire) cannot be used with single-phase building electrical supply.

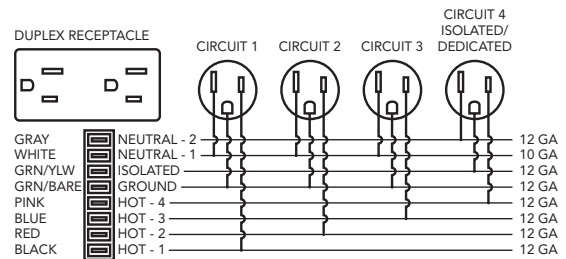

Four-circuit, 2 + 2 Receptacle Option

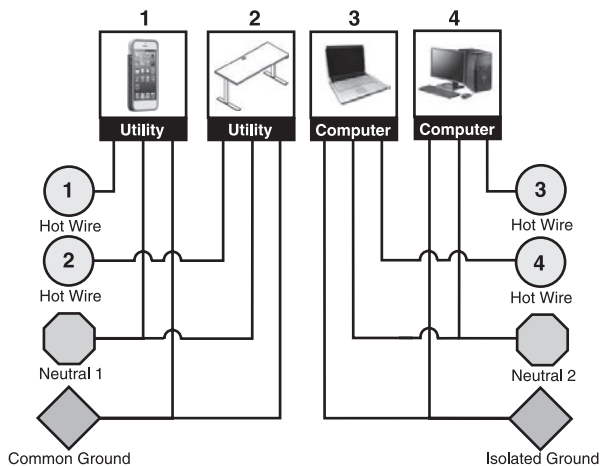

The 2 + 2 option is a wiring option that provides two utility circuits and two isolated circuits for more extensive computer usage applications.

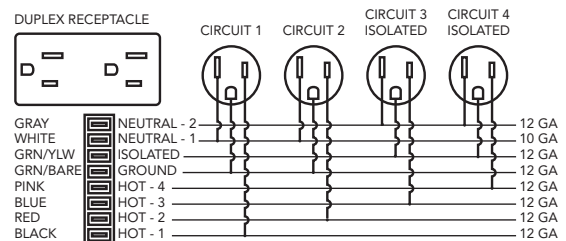

FIT

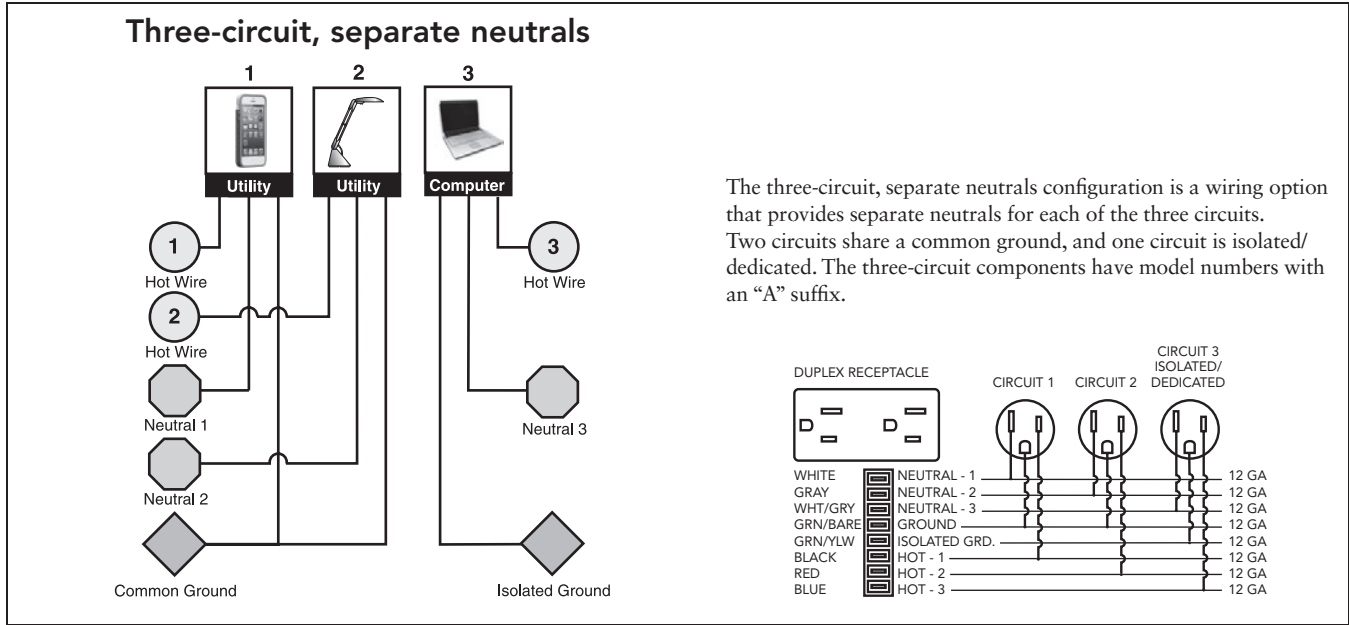

Fit System Receptacle Usage					
Two 8-wire, 20 amp (15 amp Canadian) electrical systems are offered					
Electrical System	Circuitry	Receptacle Capacity			
Four-circuit 4-Hot/2-Neutral/2-Ground	3 + 1	Common Circuit-1 A871501 A877501	Common Circuit-2 ⁽¹⁾ A871502 A877502	Common Circuit-3 A871503 A877503	Iso/Dedicated Circuit-4 A871504 A877504
	2 + 2	Common Circuit-1 A871501 A877501	Common Circuit-2 A871502 A877502	Isolated Circuit-3 A871506 A877506	Isolated Circuit-4 A871504 A877504
Three-circuit 3-Hot/3-Neutral/2-Ground	w/separate neutrals	Common Circuit-1 A871501A A877501A	Common Circuit-2 A871502A A877502A	Iso/Dedicated Circuit-3 A871503A A877503A	N/A

Notes:

- Four-circuit components and three-circuit components (with suffix “A”) cannot be used together.
- Components of the two systems are keyed differently to prevent components of one system being connected to components of another system.
- Allsteel Model Numbers are printed on the UL labels, and components are color-coded to provide visual identification of the different components.
- Four-circuit components have black plastic parts.
- Three-circuit components have rust-colored terminal ends and receptacle backs are rust colored.

(1) Circuit 2 (one of the 3 common circuits sharing a neutral wire) cannot be used with a single-phase building electrical supply.
 (2) A87150x models are for single sided applications and A87750x models are for dual sided applications.

Duplex Receptacle

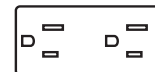

15 amp Receptacle

Office Equipment Typical Load Values

Item	*Amps
Desktop/2 Monitors	4
Laptop Computer	1
Laptop/2 Monitors/Docking Station	3
Paper Shredder	1.22
Radio	0.05
Scanner	3
Space Heater (1500 watts)	12
Task Light (equiv. 60-watt bulb)	
Fluorescent	0.12
LED	0.08
USB Charger	0.17
LCD Television (42")	1
LCD Monitor (21")	0.5
Bluetooth Speaker	0.1
Desktop Printer	
Inkjet	0.15
Laser	4 to 10
Multimedia Projector	1.7
Sit-to-Stand Height-Adjustable Desk	Idle 0.01 / Max 4
Office Kitchen	
Coffee Maker	10
Microwave	10
Toaster	12.5
Compact Refrigerator	1.5

*Chart is recommended for planning purposes. Check device specifications for exact amperage. Consult with your electrician regarding the applicable configurations.

Examples of Component Usage based on the *Office Equipment Typical Load Values Chart*

Power Option 3+1

Dedicated Circuit 4: 4 desktop computers with 2 monitors each; or 10 laptop computers
Utility Circuits 1, 2, 3: Height-adjustable tables and ancillary items

Power Option 2+2

Dedicated Circuit 3: 4 desktop computers with 2 monitors each; or 10 laptop computers
Dedicated Circuit 4: 4 desktop computers with 2 monitors each; or 10 laptop computers
Utility Circuits 1, 2: Height-adjustable tables and ancillary items

Power Option 3 (Circuit-separate neutrals)

Dedicated Circuit 3: 4 desktop computers with 2 monitors each; or 10 laptop computers
Utility Circuits 1, 2: Height-adjustable tables and ancillary items

For specification information see pages 182-188.

GSA SIN Pending

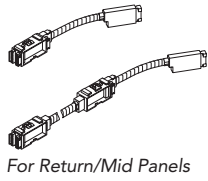

Description	Max. Recept. Cap. per Panel Side	Four-circuit 3 + 1 2 + 2	Three-circuit Separate Neutrals	List Price
Electrical Power Harnesses				
For 30" W Panels	2	A871230	A871230A	\$ 391
For 60" W Panels	2	A871260*	A871260A	\$ 416
For 66" W Panels	2	A871266*	A871266A	\$ 414
For 72" W Panels	2	A871272*	A871272A	\$ 417
For 78" W Panels	2	A871278*	A871278A	\$ 417
For 84" W Panels	2	A871284*	A871284A	\$ 417

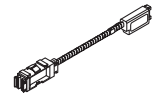

Electrical Pass-Thru Harnesses with Power Block				
For 30" W Panels	1	A871130	A871130A	\$ 239
For 60" W Panels	1	A871160*	A871160A	\$ 255
For 66" W Panels	1	A871166*	A871166A	\$ 341
For 72" W Panel Runs	1	A871172	A871172A	\$ 341
For 78" W Panel Runs	1	A871178	A871178A	\$ 341
For 84" W Panel Runs	1	A871184	A871184A	\$ 341

Electrical harnesses are intended for use with Allsteel systems furniture and are approved under GSA SIN 33721. When purchased separately and used without Allsteel systems furniture, those electrical harnesses marked by () are considered Open Market.

Note: 30" models are used for return applications only.



Electrical Pass-Thru Cable without Power Block				
For 60" W Panels	1	A871060	A871060A	\$ 229
For 66" W Panels	1	A871066	A871066A	\$ 269
For 72" W Panels	1	A871072	A871072A	\$ 269
For 78" W Panels	1	A871078	A871078A	\$ 269
For 84" W Panels	1	A871084	A871084A	\$ 269

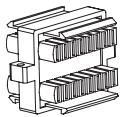

Description	Model	List Price
Sealtight Infeed to Harness Connector		
Sealtight to Harness H-Clip	A877101	\$ 54

<p>How to specify — Select the Model Number from above.</p>	<p>1st Option: Color: P Black</p>
--	---

P

Examples: A871224.P A871260.P A871060.P A8777101.P

For specification information see pages 182-188.

GSA SIN Pending



Description	Four-circuit 3 + 1 2 + 2	Three-circuit Separate Neutrals		List Price
Duplex Receptacles for Single-Sided Fit Power Rail (specify color)				
Circuit 1	A871501	A871501A	<input type="checkbox"/>	\$ 72
Circuit 2	A871502	A871502A	<input type="checkbox"/>	\$ 72
Circuit 3 (3+1)	A871503	A871503A	<input type="checkbox"/>	\$ 72
Circuit 3 (2+2)	A871506	N/A	<input type="checkbox"/>	\$ 72
Circuit 4 — iso/dedicated	A871504	N/A	<input type="checkbox"/>	\$ 72
Circuit 1, 20 AMP	A871601	A871601A	<input type="checkbox"/>	\$ 72

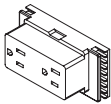

Duplex Receptacles for Dual-Sided Fit Power Rail (specify color)				
Circuit 1	A877501	A877501A	<input type="checkbox"/>	\$ 72
Circuit 2	A877502	A877502A	<input type="checkbox"/>	\$ 72
Circuit 3 (3+1)	A877503	A877503A	<input type="checkbox"/>	\$ 72
Circuit 3 (2+2)	A877506	N/A	<input type="checkbox"/>	\$ 72
Circuit 4 — iso/dedicated	A877504	N/A	<input type="checkbox"/>	\$ 72

Receptacle Color Recommended to Coordinate with Paint Color

Paint Color	Recommended Receptacle Color
Bungalow — P7C.....	Muslin — EU
Champagne Metallic — PR5.....	Muslin — EU
Cinder — P7Q.....	Brownstone — EY
Fossil — P28.....	Flint — E9
Gunmetal Metallic — PR3.....	Brownstone — EY
Parchment — P93.....	Muslin — EU
Pebble — P8R.....	Loft — EV
Pewter — P8D.....	Flint — E9
Platinum Metallic — PR2.....	Loft — EV
Salt — P8C.....	Silver — ES
Titanium — P8T.....	Silver — ES

Note: Four-circuit components and three-circuit components (with an “A” suffix) cannot be connected together.

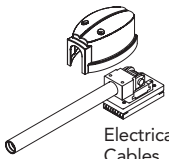

Electrical Infeed Cables

Electrical Infeed Cables				
6' Flex Cable	A871972	A871972A		\$ 331

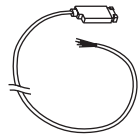

Ceiling Electrical Infeed Cables				
12' Flex Cable	A871912	A871912A	<input type="checkbox"/>	\$ 449
18' Flex Cable	A871918	A871918A	<input type="checkbox"/>	\$ 565

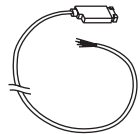

Electrical Infeed Cable

Electrical Infeed Cables				
12' Sealright Cable Power Infeed	A877012	N/A	<input type="checkbox"/>	\$ 547

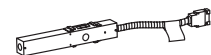

Hardwire Power Infeed (New York Code)				
For 30"–72" W panels	A871400	A871400A	<input type="checkbox"/>	\$ 431

Note: Customer to furnish all cabling and wiring from power entry to power source. (Approved for use by city of New York.)

<p>How to specify — Select the Model Number from above.</p>	<p><i>1st Option:</i> Electrical Receptacle Color (if applicable): See page 18 for finishes.</p>	<p><i>1st Option:</i> Color (if applicable): P Black</p>	<p>_____ . E _____ P</p>
--	---	---	--

Example: A877501.EV

Shippable by small-package carrier.

For specification information see pages 182-188.

GSA SIN Pending



Description	Model	List Price
Hardwire Junction Box		
Single-Sided Hardwire Junction Box (6-pack)	A871500	\$ 931
Dual-sided Hardwire Junction Box (6-pack)	877600	\$ 1145
Hardwire Infeed Junction Box Housing	U8SBKCH	\$ 336

Note: Junction box can be positioned at any duplex receptacle location. Customer must furnish conduit, wiring and designer-type receptacle. (Approved for use by city of Chicago.)
 Hardwire Infeed Housing model U8SBKCH must be ordered when using Rail Hardwire Infeed Shroud BW and BH models GSYSHWBW and GSYSHWBH.



Description	Model	List Price
Data Faceplates		
Three-Port Flex-Mode Faceplate, Black (E4)	ATADF3 S	\$ 42
Four-Port Flex-Mode Faceplate, Black (E4)	ATADF4 S	\$ 42

Notes: ATADF3 can install up to 3 jacks (CAT 3, 5E or 6). ATADF4 can install 4 jacks (CAT 3, 5E or 6).

ATADF models are compatible with ports in Optimize base pathway.

Allsteel's data faceplates are designed for use with the jacks listed below. We do not guarantee compatibility with other manufacturers' product. A faceplate adapter is available for use with alternatively sourced data jacks, see the Standard Specials catalog for details.



ATADJ5

Description	Model	List Price
Jacks		
RJ45 CAT 5E Jack — Black only Toolless	ATADJ5 S	\$ 74
RJ45 CAT 6 Jack — Black only Requires Tool	ATADJ6 S	\$ 98

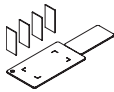

GSYSRPC2

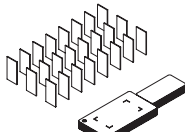

GSYSRPC12

Description	Model	P1 List Price	P2 List Price	P3 List Price
Rail Port Cover				
Rail Port Cover (Pack of 2)	GSYSRPC2 (shown)	\$ 61	\$ 65	\$ 68
Rail Port Cover (Pack of 12)	GSYSRPC12 (shown)	\$ 226	\$ 236	\$ 246

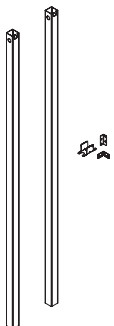

GSYSPP

Description	Model	P1 List Price	P2 List Price	P3 List Price
Integrated Power/Communication Pole for Fit				
13' long — 2" square	GSYSPP (shown)	\$ 2979	\$ 3049	\$ 3116

FIT

<p>How to specify — Select the Model Number from above.</p> <p>_____ . E _____</p>	<p>1st Option: Electrical Receptacle Color (if applicable): See page 18 for finishes.</p> <p>P _____</p>	<p>1st Option: Color (if applicable): P Black</p> <p>P _____</p>	<p>1st Option: Paint (if applicable): P1 P2 P3 See page 18 for finishes.</p> <p>P _____</p>
--	---	---	---

Examples: A871500.P ATADF3.P

S Shippable by small-package carrier.

Notes

FIT

Finishes	68
Typicals Overview	69
Specifications	
Introduction and Overview	70-71
Working with Panels, Connectors, and Sliding Doors	72-75
Panels & Connectors	
Tackable Panels and Stacking Panels.....	76
Top Trim	77
Glazed Panels and Glazed Stacking Panels.....	78
Screens and Doors.....	79
Connectors — In-line, “L”, “T”, “X”, Extended Straight, and Connector Straps.....	80-81
Connectors — End Trim, Variable Height, Wall Mount, 2-Way, and 3-Way	82
Electrical & Data	
Working with Electrical & Data	83-91
Harnesses	92
Receptacles, Infeeds, Hardwire, and Poles.....	93
Electrical and Data Components.....	94
Worksurfaces & Supports	
Overview of Worksurfaces	95
Working with Worksurfaces and Supports.....	96-101
Working with Cadence® Freestanding Desking	102-110
Laminate Worksurfaces	
Primary and Bow-Front Worksurfaces	111-112
Corner, Corner Shelves, and Corner Cove	113-114
Altitude® Height-Adjustable Reference.....	114
Peninsula, P-Shaped, and Jetty	115
Quarter-Round and D-Shaped	116
Countertops and Countertop Brackets.....	117
9120 Program for Non-Standard Sizes	118-119
Worksurface Supports, Panel-Mount Worksurface Supports and Brackets	120
Cadence Worksurface Supports and Modesty Panels	121-122
Metal Overheads & Hutches	
Working with Overhead Storage	123-126
Overheads, Shelves, and Mounting Kits	127-128
Hutches, Tackboards, and Accessories	129

PAINTED METAL FINISHES

GRADE P1

Black	P27
Brownstone	P7D
Bungalow	P7C
Cinder	P7Q
Cove	P096
Designer White	PJW
Dune	P094
Flint	P02
Fossil	P28
Harbor	P097
Loft	P7B
Muslin	P4J
Parchment	P93
Pebble	P8R
Pewter	P8D
Sage	P095
Salt	P8C
Titanium	P8T

GRADE P2

Champagne Metallic	PR5
Gunmetal Metallic	PR3
Platinum Metallic	PR2
Silver	PR6
Solar Black	P8X

Metallic paints, due to varying reflectance, may appear to have less visual color consistency than other paint finishes, even when L/A/B values are exactly the same. (L/A/B — measurable aspects of color — values are maintained within a specified range, to ensure consistent appearance of paint colors.)

GRADE P3

Atom	P8S
Blossom***	P8K
Bullseye	PJF
Ember	P8P
Ion	P8N
Iris	P8J
Krypton	P8F
Ochre	P093
Regatta	P8M
Sienna	P092
Succulent***	P8A

***These colors are intended to be an inspirational option for the trending market. Product application is limited and color availability is approximately two years to coincide with evolving workplace trends.

METAL STORAGE PULLS

Black	E4
Matte Silver	EL

ELECTRICAL AND DATA COMPONENTS

Black	E4
Brownstone	EY
Designer White	DW
Flint	E9
Loft	EV
Muslin	EU
Silver	ES

Recommended Coordinate Colors:
 Bungalow use Muslin EU
 Champagne Metallic use Muslin EU
 Cinder use Brownstone EY
 Fossil use Flint E9
 Gunmetal Metallic use Brownstone EY
 Parchment use Muslin EU
 Pebble use Loft EV
 Pewter use Flint E9
 Platinum Metallic use Silver ES
 Salt use Silver ES
 Titanium use Silver ES

OPTIMIZE REPLACEMENT RECEPTACLE COVERS

Black	E4
Muslin	EU
Shadow	SH

LAMINATES

GRADE L1

SOLID COLORS	
Black	P
Brownstone*	LM13
Bungalow*	LM12
Designer White*	LDW1
Flint*	LM16
Fossil Shale*	LEH1
Loft*	LM11
Muslin*	LM15
Titanium*	LTI1

ABSTRACT

Ash	IT3B
Handspun Pearl	LHP
Handspun Dove	LAHD
Handspun Slate	LAHS
Handspun Chestnut	LAHC
Silver Mesh	LT8D

WOODGRAIN

Belair	LWBA
Bourbon Cherry	H
Field Elm	LWFE
Florence Walnut*	LFW1
Kingswood Walnut*	LKI1
Natural Maple*	LWD
NeoWalnut*	LNU1
Pinnacle	PINC
Shaker Cherry*	LW7C

GRADE L2

Beigewood*	LWBE
Fawn Cypress*	LFC1
Lowell Ash*	LLA1
Mangalore Mango*	LMM1
Natural Recon*	LNR1
Phantom Charcoal*	LPC1
Phantom Ecu*	LPE1
Portico Teak*	LPT1
Skyline Walnut*	LSW1
Veranda Teak	LVT1

GRADE L3

Natural Walnut*	LWNW
-----------------	------

* Storage available in these 30 laminates.

LAMINATE EDGE COLORS

Beigewood	DE
Belair	BA
Black	E4
Bourbon Cherry	H
Brownstone	EY
Bungalow	EX
Designer White	DW
Fawn Cypress	FC
Field Elm	FE
Flint	E9
Florence Walnut	FW
Fossil	EH
Kingswood Walnut	KI
Loft	EV
Lowell Ash	DL
Mangalore Mango	MM
Muslin	EU
Natural Maple	DD
Natural Recon	NR
Natural Walnut	DN
NeoWalnut	NU
Parchment	EN
Phantom Charcoal	PC
Phantom Ecu	PE
Pinnacle	PI
Platinum Metallic	EP
Plyband ♦	PL
Portico Teak	DP
Shaker Cherry	DF
Skyline Walnut	SW
Titanium	TI
Veranda Teak	VT

♦ Edge is limited to flat edge surfaces: rectangle, square, trapezoid, polygon, or round. No curvilinear or combination curve and straight.

METAL GROMMETS

FOR LAMINATE WORKSURFACES

Oval/Square	
Matte Silver	EL

PLASTIC GROMMETS

FOR WORKSURFACES

Black	E4
Brownstone	EY
Bungalow	EX
Designer White	DW
Flint	E9
Fossil	EH
Loft	EV
Muslin	EU
Parchment	EN
Titanium	TI

PLASTIC GROMMETS WITH WOODGRAIN EDGE

If woodgrain edge is specified, the plastic grommet color is predetermined, based on finish selection.

Beigewood, Fawn Cypress, Natural Maple, and Natural Recon	Muslin EU
Kingswood Walnut and NeoWalnut	Brownstone EY
Phantom Charcoal and Skyline Walnut	Flint E9
Phantom Ecu	Loft EV
Portico Teak	Fossil EH
All other woodgrain options	Black E4

LOCKS

Matte Silver	EL
--------------	----

Note: Refer to individual product pages for upcharges.

Workstations made easier.

Whether you're outfitting a call center, creating teaming areas, replacing a reception desk, or adding new stations for managers, Allsteel can help you make the most of your office with Optimize. By bringing together panels, worksurfaces, and storage in one cohesive offering, we've made it easy for you to create efficient, well-designed spaces. All you have to do is configure these quality components to fit the needs of everyone in your office. Let us show you how.

Optimize makes a good first impression.

In areas open to the public, choose panels, worksurfaces, and storage to define space and keep projects organized. In this reception/shared workspace, a transaction countertop welcomes guests and worksurfaces below provide ample space for computers and paperwork.

We help you put it all together.

An open configuration with lower panels and a small footprint is perfect for people who perform the same function and need to share information throughout the day. Optimize benching can utilize tool rails and monitor arms to keep items off the desktop. An integrated D-shaped worksurface makes it easy for workers to come together to collaborate and then quickly return to their personal work areas.

As work changes, Optimize changes with you.

Optimize helps workers adjust workstyles throughout the day, from concentrated work to team brainstorming. In team areas, each person can have ample privacy, roomy storage with overhead bins, as well as a spacious worksurface for individual tasks. When it's time to collaborate, a table within the workspace and mobile pedestals that double as seating make it easy to come together.

Make the most of your space.

With Optimize panels, worksurfaces, and storage, you can create stations that feel like private offices. Higher panels promote privacy along the aisle while glass stackers near windows bring natural light into the space. Plenty of enclosed, lockable storage above and below the worksurface holds sensitive information. A U-shaped worksurface arrangement creates a natural conference area to accommodate conversations with team members or clients.

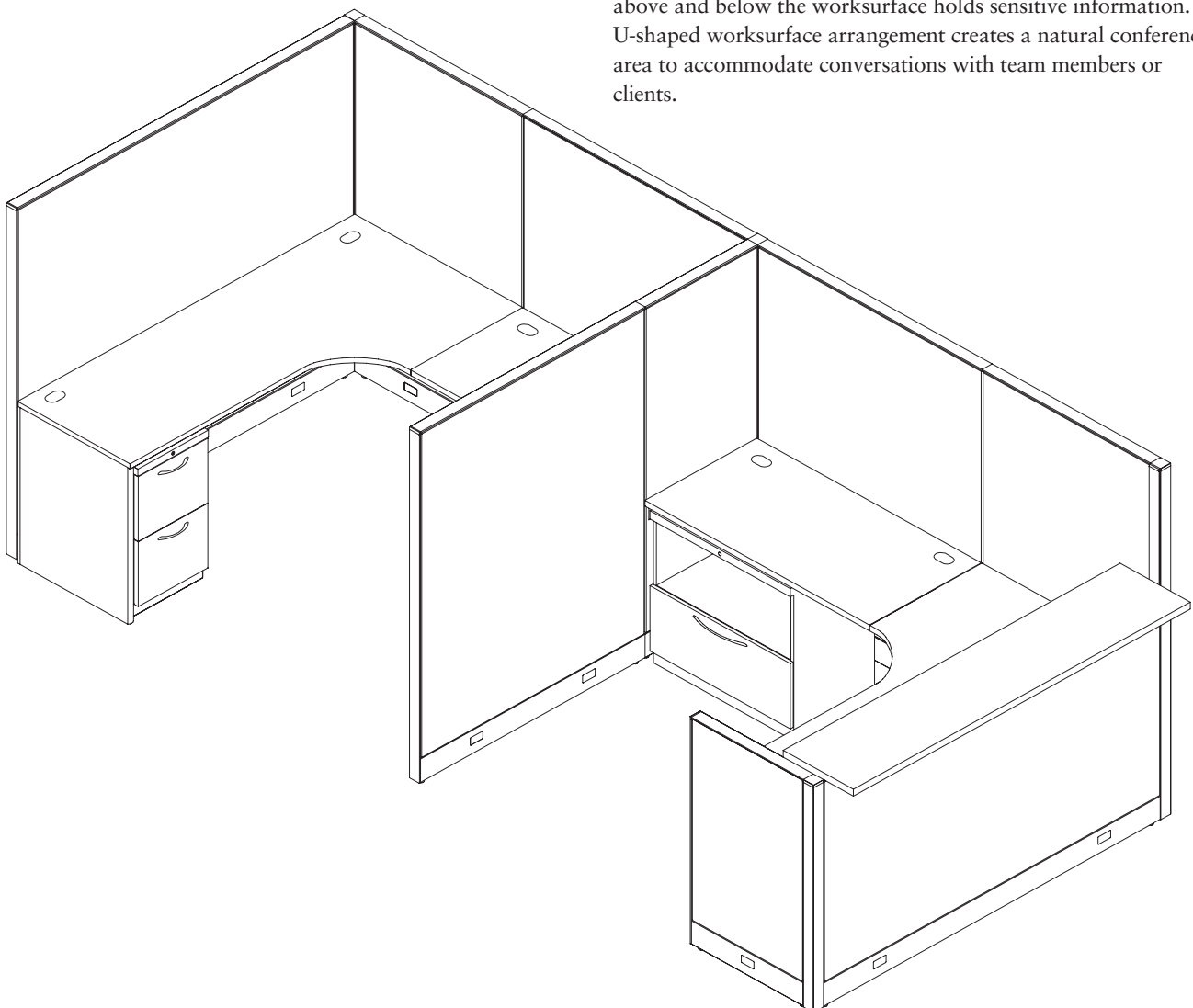

OPTIMIZE

[GSA Reference Page](#)

BASE RACEWAY PANELS — Tackable

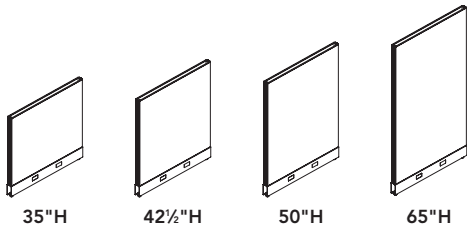

BASE RACEWAY PANELS — Tackable Glazed

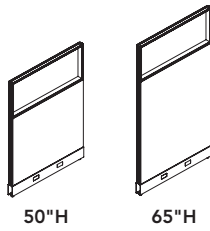

TOP TRIM



STACKING PANELS — Tackable and Glazed

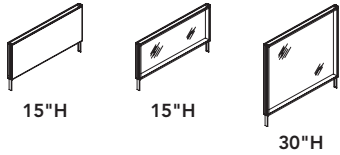

DOORS



Hinged Door
80"H



Sliding Door
50"H/65"H/80"H



Connector Kits — Optimize profile

- "TT" In-line Connector Kit
- "L" 90° Connector Post
- "T" 3-way Connector Post
- "X" 4-way Connector Post
- "S" Extended Straight Connector Post
- "V" 2-Way 120° Connector Post
- "Y" 3-Way 120° Connector Post

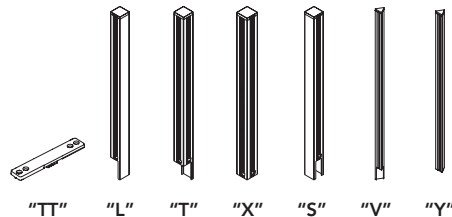

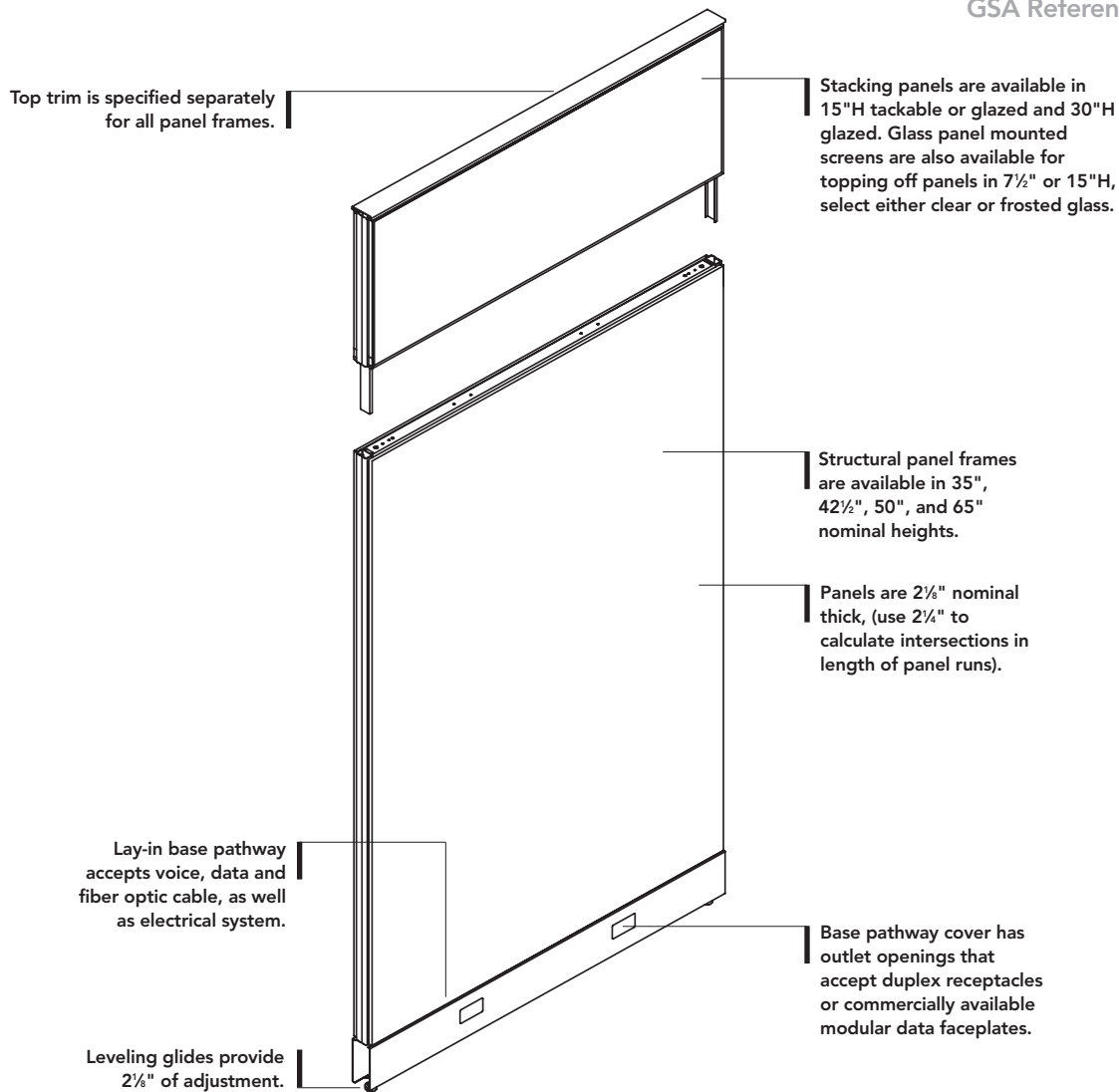

Frame Dimensions (Actual)

Depth: 2⅝" (use 2¼" to calculate intersections in length of panel run)

Widths: 20", 24", 30", 36", 42", 48", 60", 72"

Heights: 34¼", 41¼", 49¼", 64¼" (with levelers fully retracted)

Leveling Glides: 2⅝" range

Stacking Panels: 15"H fabric and glass, 30"H glass

Frameless Glass Screens: 7½"H, 15"H

Tackable Panels (pages 76-77)

- Specifications: 4-sided, welded tubular steel panel frame.
- Panel frames include and are shipped with base pathway covers installed. Top trim is specified separately for all panel frames.
- Hardware included with connector kits.
- Available in 4 heights and 8 widths — add ⅜" for each panel vertical end trim.
- Panel frames can be leveled up to 2⅝". Actual panel height varies depending on position of leveling glides.
- Direct connections between same height frames in a continuous run are accomplished with provided hardware. There is no incremental increase in dimension along the run.
- For adequate stability, one of two methods of stabilization shown on page 73 must be adhered to.
- Due to depth of panel, back-to-back data modules should not be used in the base. Optional 3-hole kickplates are available.
- Add 2¼" to panel run for each "L", "T", "X", or extended straight connector ("S").
- Acoustical panels meet BIFMA recommendations.
- Fabric selection for 72"W panels is limited. Fabrics that are unavailable on 72"W panels are flagged with a * on page 10 of this price list.

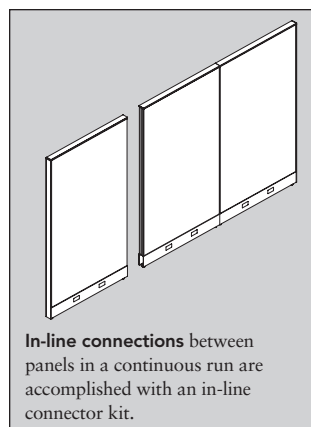
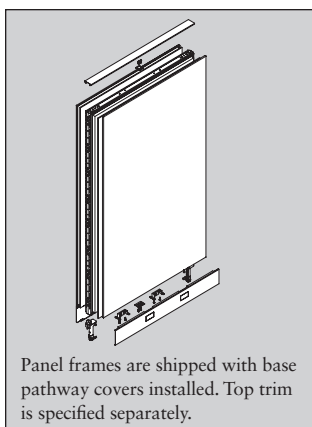

Building Vertically with Optimize Panels

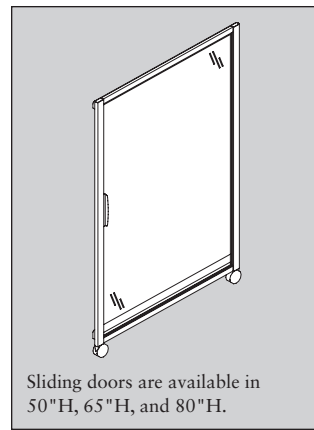
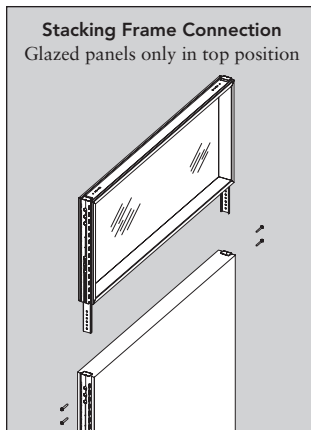
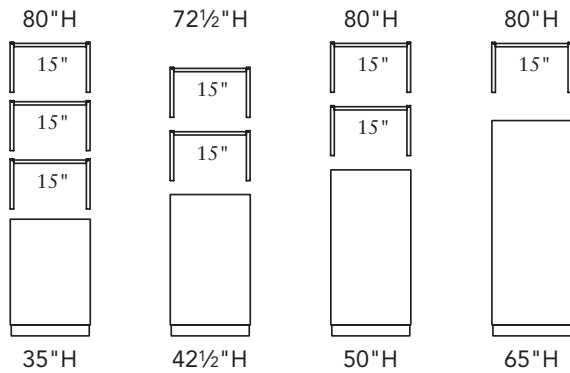

Building Horizontally with Optimize Panels

Method 1—Opposing Returns

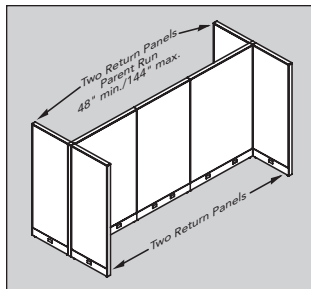

Method 2—Single-Sided Returns

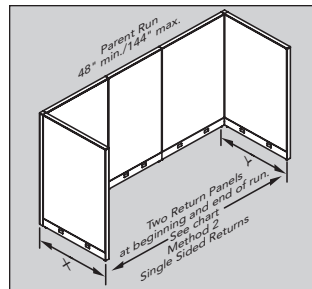

Important planning guidelines: For adequate stability, one of two methods of stabilization must be adhered to:

Method 1 — Opposing returns

- A parent run must be a minimum of 48" and a maximum of 144" between return panels.
- The parent run must have a minimum of two 24"W return panels running in opposing directions on each end of run.
- Return panels must not be any more than 30" shorter in height than parent run.
- When using 120° connectors, 12" must be added to length of return panels as determined by methods 1 and 2.

Method 2 — Single-sided returns

- A parent run must be a minimum of 48" and a maximum of 144" between return panels.
- The parent run must have a minimum of two return panels extending in one direction. Stack-ons may require additional length. See chart.
- Return panels must not be any more than 30" shorter in height than parent run.

Stacking Tackable and Glazed Panels (pages 76 and 78)

- When adding stacking panels, remove the top trim from the structural panel, and install top trim on top of the stacking panel.
- Stacking connection provides a solid connection, allowing the stacking frame to accept hang-on components, per Optimize configuration guidelines at left.
- Includes attachment hardware. Specify connectors separately.
- Only one stacking glazed panel can be added to top position of any Optimize panel of same width from 20"W to 72"W up to a maximum combined height of 80".
- End trim is specified in full end height to include height of base panel + stacking panel.
- Guidelines for using overhead storage with stacking frames are given on page 124.
- Stacking glazed panels feature clear or frosted tempered safety glass inserts (specified). Glass frame is painted to match trim.
- Stacking frames can be added to the top of same width 35"H, 50"H, and 65"H base panels up to 80"H; added to 42½"H panels up to 72½"H.
- Slot modularity will be lost on stacker used with 42½"H panels. If panel mounting slots are not being used, this is not an issue.
- Do not combine differing frame widths in a single stack. No spanning multiple frames.
- Stacking frames cannot be used as base frames.
- Fabric selection for 72"W panels is limited. Panel fabrics that are not available on 72"W panels are flagged with a "*" on page 10 of this price list.

Tackable Glazed Panels (page 78)

- Available 50"H and 65"H with 15"H clear or frosted tempered safety glass inserts (specified).
- Glass frame is painted to match trim.
- Top trim is specified separately.
- Cannot stack on glazed panels.
- Fabric selection for 72"W panels is limited. Available 72"W panel fabrics are flagged with a "W" on page 10 of this price list.

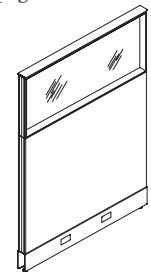

Glass Panel Mounted Screens (page 79)

- Frameless insert integrated into the base panel frame top trim.
- Replaces top trim on structural or stacking tackable frame.
- It is possible to span multiple frames when the combined frame width is equal to the panel mounted screen width.
- Can do variable height, must be used with grooved VH trim.
- Panel mounted screens are non-structural. Do not hang or stack on top of panel mounted screens.
- Available in ⅜" thick clear or frosted glass.
- To be included in overall height of panel with a maximum combined height of 80".

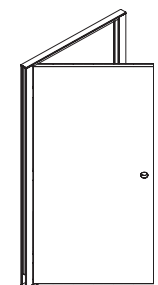

Door Panel Frame (page 79)

- The 80"H door panel frame includes 42"W frame, 36"W laminate door, hinges, and attaching hardware. Top trim is specified separately.
- See illustration at right.
- Lockset with knob or lever ordered separately.

Optimize Sliding Doors and Mounting Kits (pages 75 and 79)

- Optimize sliding doors are available in 50"H, 65"H, and 80"H.
- See illustration and specification information on page 75.

Method 2 – Single-sided Returns

Single-Sided Panel Run	Minimum Return Panels Total (X+Y)	Minimum Return Panels Total (X+Y) with Stack-ons
48"-108"	84"	84"
114"-144"	84"	96"

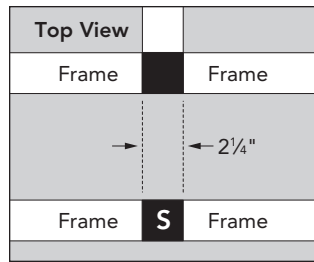
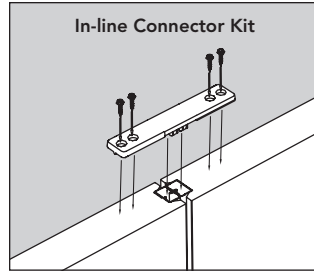
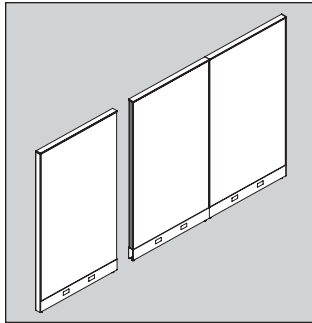

Extended Straight "S" Connection

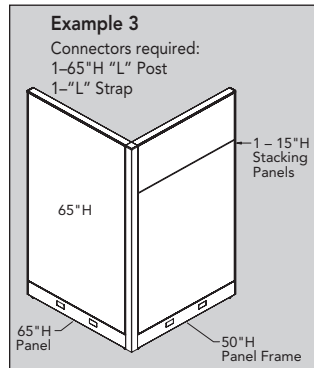

Example 3
Connectors required:
1-65"H "L" Post
1-"L" Strap

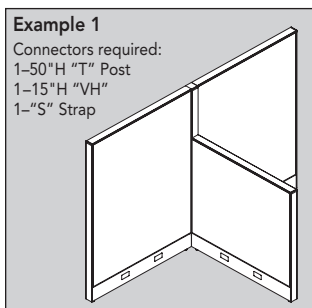
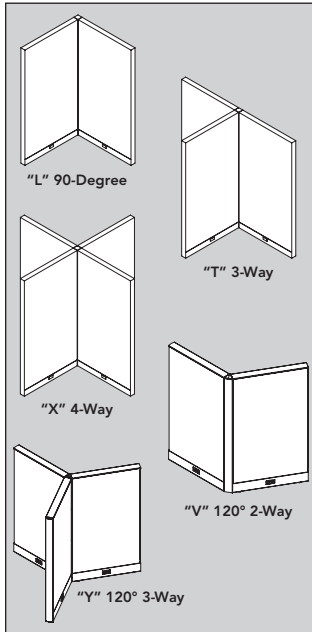

Example 1
Connectors required:
1-50"H "T" Post
1-15"H "VH"
1-"S" Strap

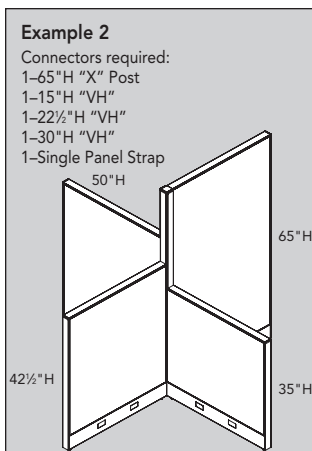

Example 2
Connectors required:
1-65"H "X" Post
1-15"H "VH"
1-22 1/2"H "VH"
1-30"H "VH"
1-Single Panel Strap

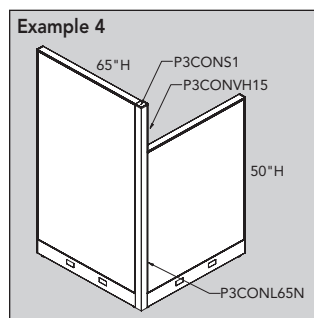

Example 4
Example above represents Optimize variable height connection for 65"H to 50"H.

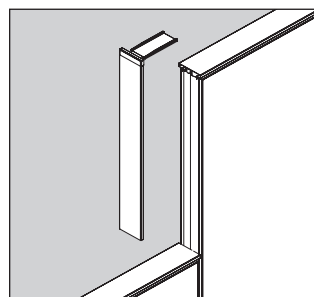

High-Low "H"

Connectors and Trim

In-line Connector Kit (page 80)

- In-line connections between panels in a continuous run are accomplished with an in-line connector kit. There is no incremental increase in dimension along the run.
- In-line connector kits include all parts required for connecting two panels of same height together.
- Kit includes in-line connector strap, hardware, and glide tower to glide tower screw.
- Order panel end trim kits to finish the end of every panel run (except when attaching panels to permanent walls).

"L", "T", "X", "S", "V", and "Y" Connectors (page 80)

- "L", "T", "X", "V", and "Y" connectors kits are used when connecting panels at intersecting runs. For "L", "T", and "X" connections connector kits, add 2 1/4" to the total length of the panel run for each intersection, whether located in the middle or at the end of the run.
- Specify connectors based on number and placement of panels.
- Connector posts are specified separately from connector straps—specify post based on tallest panel height and type of panel connection, specify straps based on connection of tallest panels (see variable height examples left).
- Connectors are made of extruded aluminum.
- Connector posts where power pole will enter need to be specified with single connector straps, model P3CONS1.
- Extended straight connector kit "S" can be used to keep continuous runs dimensionally consistent with opposing panel runs which incorporate "T" or "X" intersections.
- Add 2 1/4" to the length of the run for every extended straight connector used.

Multiple-Height Connections (page 80)

- Multiple-height connections also utilize standard "L", "T", "X", and "S" connectors, in the height of the tallest panel. (See examples 1-4 at left.)

Panel End Trim (page 82)

- End vertical trim cover (includes top cap — adds 3/8" to run).
- Order to finish the end of every panel run (except when attaching panels to permanent walls).

Variable Height Connector Kits — Post Trim (page 82)

- Includes connectors, vertical cover, and attaching hardware.
- Order one per each panel height change in an "L", "T", "X", or "S".

Grooved VH Finishing Kit (page 82)

- For use when the base panel frame of a panel mounted screen is shorter than the adjacent panel

In-line Variable Height End Trim Finish Kits (page 82)

- End vertical cover (includes top cap).
- High-low "H" covers the exposed end of a panel when joining panels in-line of differing heights. Optimize profile adds 3/8" to length of panel run.
- Order one per each panel height change in an in-line connection.
- At the end of a panel run use panel end trim.

Wall Mount Kits (page 82)

- Wall mount kits provide a means to affix a panel run to a permanent building wall.
- Includes top cap. (Color must be specified.)
- Connector adds 1" to length of panel run.
- Anchor devices are not supplied with the wall mount kit. Refer to Optimize Installation Instructions for appropriate hardware.

2-Way 120° Connector Kits (page 82)

- Includes top cap, connectors, vertical cover, and attaching hardware.

3-Way 120° Connector Kits (page 82)

- Includes top cap and connectors.

The sliding doors must be specified with specific mounting kits for each door ordered. With a Frosted Translucent insert and your choice of P1 or P2 paint, the sliding door will create a unique look for any office environment.

The sliding doors are available in 50", 65", and 80" H models and can mount to 30", 36", 42", and 48" W panels. They accommodate a 36" W opening and are 42" W, nominally. The doors ship from the factory non-handed and become handed when field installed to fit the scope of the project. The handle pulls located on each side of the door are color matched to the trim to create a uniform style. And with the threshold free design, the sliding door offers better aesthetics and safety by eliminating the potential for tripping.

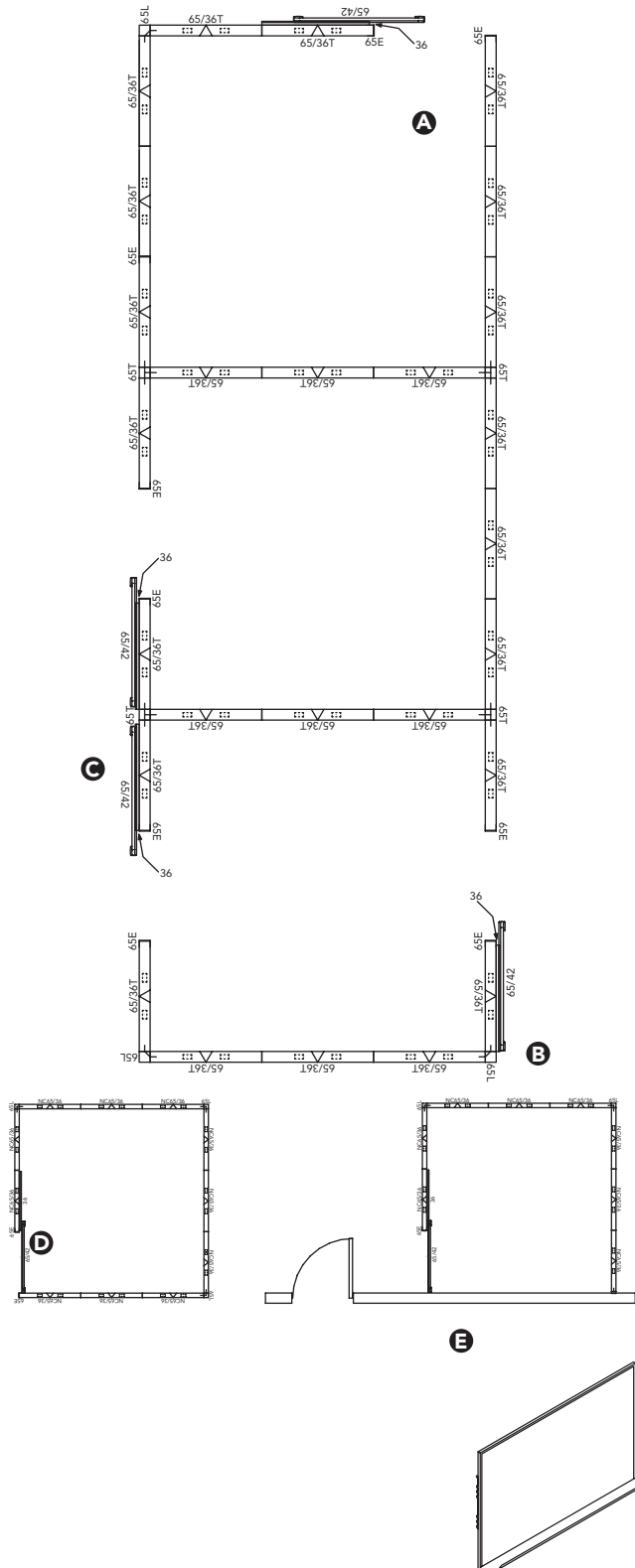

General Guidelines for Use of Sliding Door (page 79)

- The system requires the ordering of both a door and a mounting bracket kit.
- All doors are 42" wide to accommodate a 36" W opening and are non-handed .
- A mounting bracket kit must be ordered for each door corresponding to the mounting panels width (30", 36", 42", or 48" W). Kits available in P1 and P2 paint.

General Guidelines for Layout Planning of Sliding Door

- Stability guidelines must be followed when specifying a sliding door. (Refer to page 73). The sliding door system was designed to close an opening in a run of parallel panels. Doors mounted to long runs of panels without floor support, ties to worksurfaces, or return panels may seem less stable.
- If the door is used to close an opening (A) where the panel opposite the door is at 90°, there will be a gap equal to the panel thickness between the door and the panel end when closed.
- When planning the layout, care must be taken if the plan includes a door mounted on a panel that is less than 42" W. If the panel is at a corner (B), the door will protrude into the aisle or next workstation when in the open position.
- If back-to-back doors are mounted on panels (C) that are less than 42" W they will interfere with each other if both are open at the same time.
- The door is attached at the base of the panel at any end position with a wrap around bracket. Bracket kits are ordered in conjunction with appropriate end trim profiles. The slots at the base of the panel must be clear (D) and cannot be utilized by worksurface supports or panel hung components.
- If the door is mounted to a panel run that is positioned adjacent to a wall (E) or an inside 90° angle and there is not a 42" clearance between the track and the wall/inside 90° the assembly of the first stop will be difficult and plans will need to be modified for the assembly.
- If a door is closing an opening of a workstation that includes a "T" connector in the opposite wall, an extended straight connector may need to be used to maintain the 36" required opening.

Marker Board (page 77)

- For use with dry marking pens.
- Hangs directly on Optimize™ panel frame.
- Brackets must be field re-located for use with other systems.
- Porcelain-coated steel surface.
- White with silver trim.
- Width must correspond with width of panel.

For specification information see pages 71-75.

GSA SIN 33721

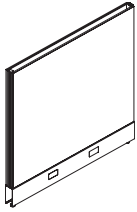

Description	Model Without Top Trim	List Price Without Top Trim					
		Grade A	Grade B	Grade C	Grade D	Grade E	Grade F
35"H Tackable Panel							
24"W	P13524TP [S]	\$ 529	\$ 571	\$ 611	\$ 710	\$ 833	\$ 914
30"W	P13530TP [S]	\$ 577	\$ 622	\$ 663	\$ 774	\$ 906	\$ 993
36"W	P13536TP [S]	\$ 641	\$ 689	\$ 735	\$ 859	\$ 1007	\$ 1105
42"W	P13542TP [S]	\$ 660	\$ 710	\$ 756	\$ 882	\$ 1034	\$ 1134
48"W	P13548TP [S]	\$ 707	\$ 760	\$ 815	\$ 950	\$ 1113	\$ 1221
60"W	P13560TP [S]	\$ 794	\$ 854	\$ 917	\$ 1075	\$ 1264	\$ 1389
72"W	P13572TP [S]	\$ 1006	\$ 1083	\$ 1160	\$ 1349	\$ 1584	\$ 1740

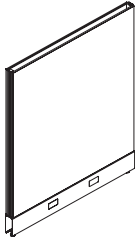

42½"H Tackable Panel							
24"W	P14224TP [S]	\$ 558	\$ 602	\$ 642	\$ 750	\$ 876	\$ 963
30"W	P14230TP [S]	\$ 624	\$ 671	\$ 716	\$ 834	\$ 978	\$ 1074
36"W	P14236TP [S]	\$ 699	\$ 751	\$ 802	\$ 934	\$ 1095	\$ 1202
42"W	P14242TP [S]	\$ 769	\$ 826	\$ 884	\$ 1026	\$ 1201	\$ 1316
48"W	P14248TP [S]	\$ 820	\$ 880	\$ 943	\$ 1100	\$ 1287	\$ 1412
60"W	P14260TP [S]	\$ 951	\$ 1024	\$ 1097	\$ 1283	\$ 1504	\$ 1652
72"W	P14272TP [S]	\$ 1096	\$ 1179	\$ 1261	\$ 1472	\$ 1724	\$ 1892

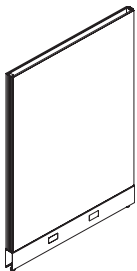

50"H Tackable Panel							
24"W	P15024TP [S]	\$ 614	\$ 660	\$ 705	\$ 820	\$ 960	\$ 1055
30"W	P15030TP [S]	\$ 686	\$ 736	\$ 787	\$ 918	\$ 1076	\$ 1179
36"W	P15036TP [S]	\$ 776	\$ 833	\$ 892	\$ 1036	\$ 1211	\$ 1329
42"W	P15042TP [S]	\$ 863	\$ 927	\$ 990	\$ 1152	\$ 1345	\$ 1474
48"W	P15048TP [S]	\$ 929	\$ 997	\$ 1065	\$ 1243	\$ 1453	\$ 1592
60"W	P15060TP [S]	\$ 1010	\$ 1088	\$ 1166	\$ 1362	\$ 1600	\$ 1754
72"W	P15072TP [S]	\$ 1234	\$ 1325	\$ 1418	\$ 1652	\$ 1933	\$ 2119



65"H Tackable Panel							
24"W	P16524TP [S]	\$ 671	\$ 720	\$ 769	\$ 894	\$ 1050	\$ 1148
30"W	P16530TP [S]	\$ 760	\$ 816	\$ 873	\$ 1015	\$ 1186	\$ 1302
36"W	P16536TP [S]	\$ 853	\$ 917	\$ 978	\$ 1137	\$ 1329	\$ 1456
42"W	P16542TP [S]	\$ 947	\$ 1017	\$ 1087	\$ 1264	\$ 1477	\$ 1616
48"W	P16548TP [S]	\$ 1000	\$ 1074	\$ 1148	\$ 1334	\$ 1561	\$ 1710
60"W	P16560TP [S]	\$ 1093	\$ 1176	\$ 1260	\$ 1473	\$ 1726	\$ 1897
72"W	P16572TP [S]	\$ 1357	\$ 1455	\$ 1560	\$ 1816	\$ 2122	\$ 2326

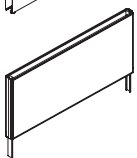

15"H Stacking Panel — Fabric							
24"W	P21524T [S]	\$ 383	\$ 412	\$ 425	\$ 488	\$ 541	\$ 622
30"W	P21530T [S]	\$ 421	\$ 452	\$ 466	\$ 538	\$ 596	\$ 687
36"W	P21536T [S]	\$ 468	\$ 504	\$ 517	\$ 598	\$ 665	\$ 762
42"W	P21542T [S]	\$ 508	\$ 546	\$ 560	\$ 648	\$ 719	\$ 826
48"W	P21548T [S]	\$ 545	\$ 586	\$ 601	\$ 697	\$ 774	\$ 887
60"W	P21560T [S]	\$ 742	\$ 794	\$ 820	\$ 948	\$ 1053	\$ 1209
72"W	P21572T [S]	\$ 785	\$ 840	\$ 867	\$ 1004	\$ 1115	\$ 1281

How to specify —
Select the Model Number from above.

1st Option:
Panel Fabric:
See page 10 for fabrics.

Limited selection for 72"W models.

2nd Option:

Paint:
P1 P2 P3

See page 68 for finishes.

For P2 paints — add \$46.
For P3 paints — add \$92.

P _____ . _____ . _____

Examples: P13524TP.ECH901.P7B P16572TP.APN911.P7B

[S] Shippable by small-package carrier.



Description	Model	P1 List Price	P2 List Price	P3 List Price
Painted Top Trim for Tackable (Examples span multiple panels)				
24"W	P1AOP-TC24 S	\$ 44	\$ 47	\$ 48
30"W	P1AOP-TC30 S	\$ 45	\$ 48	\$ 49
36"W	P1AOP-TC36 S	\$ 46	\$ 49	\$ 50
42"W	P1AOP-TC42 S	\$ 48	\$ 51	\$ 53
48"W-- 24" + 24"	P1AOP-TC48 S	\$ 56	\$ 59	\$ 61
60"W - 30" + 30" or 24" + 36"	P1AOP-TC60 S	\$ 64	\$ 67	\$ 69
72"W - 36" + 36" or 24" + 48"	P1AOP-TC72 S	\$ 80	\$ 84	\$ 87

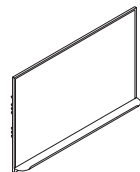

Description	Model	List Price
Marker Board		
36"W x 24"H	AMRK36 S	\$ 773
42"W x 24"H	AMRK42 S	\$ 841
48"W x 24"H	AMRK48 S	\$ 871

How to specify —
Select the Model Number from above.

1st Option:

Paint:

P1 P2 P3

See page 68 for finishes.

Example: **P1AOP-TC24.P7B**

S Shippable by small-package carrier.

Panels

For specification information see pages 71-75.

GSA SIN 33721

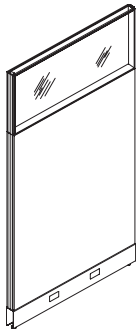
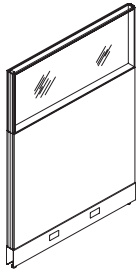
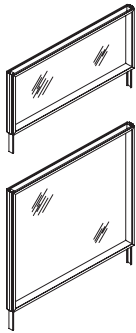

Description	15"H Model	30"H Model	15"H List Price		30"H List Price		
			Clear	Frosted	Clear	Frosted	
Stacking Panel — Glazed							
24"W	P21524G <input checked="" type="checkbox"/>	P23024G <input checked="" type="checkbox"/>	\$ 706	\$ 755	\$ 1207	\$ 1285	
30"W	P21530G <input checked="" type="checkbox"/>	P23030G <input checked="" type="checkbox"/>	\$ 743	\$ 795	\$ 1318	\$ 1402	
36"W	P21536G <input checked="" type="checkbox"/>	P23036G <input checked="" type="checkbox"/>	\$ 829	\$ 887	\$ 1429	\$ 1519	
42"W	P21542G <input checked="" type="checkbox"/>	P23042G <input checked="" type="checkbox"/>	\$ 959	\$ 1025	\$ 1516	\$ 1610	
48"W	P21548G <input checked="" type="checkbox"/>	P23048G <input checked="" type="checkbox"/>	\$ 1070	\$ 1144	\$ 1592	\$ 1690	
60"W	P21560G <input checked="" type="checkbox"/>	P23060G <input checked="" type="checkbox"/>	\$ 1139	\$ 1218	\$ 1699	\$ 1808	
72"W	P21572G	N/A	\$ 1210	\$ 1294	N/A	N/A	

Description	Model Without Top Trim	List Price Without Top Trim					
		Grade A	Grade B	Grade C	Grade D	Grade E	Grade F
50"H Tackable Glazed Panel w/15"H Clear Glass							
24"W	P15024HP <input checked="" type="checkbox"/>	\$ 1029	\$ 1106	\$ 1178	\$ 1369	\$ 1600	\$ 1753
30"W	P15030HP <input checked="" type="checkbox"/>	\$ 1127	\$ 1209	\$ 1291	\$ 1498	\$ 1749	\$ 1915
36"W	P15036HP <input checked="" type="checkbox"/>	\$ 1230	\$ 1319	\$ 1409	\$ 1635	\$ 1908	\$ 2090
42"W	P15042HP <input checked="" type="checkbox"/>	\$ 1346	\$ 1441	\$ 1542	\$ 1789	\$ 2085	\$ 2284
48"W	P15048HP <input checked="" type="checkbox"/>	\$ 1399	\$ 1501	\$ 1604	\$ 1865	\$ 2174	\$ 2383
60"W	P15060HP	\$ 1601	\$ 1720	\$ 1838	\$ 2141	\$ 2504	\$ 2743
72"W	P15072HP	\$ 1953	\$ 2097	\$ 2240	\$ 2604	\$ 3040	\$ 3329

50"H Tackable Glazed Panel w/15"H Frosted Glass							
24"W	P15024HP <input checked="" type="checkbox"/>	\$ 1106	\$ 1183	\$ 1255	\$ 1446	\$ 1677	\$ 1830
30"W	P15030HP <input checked="" type="checkbox"/>	\$ 1209	\$ 1291	\$ 1373	\$ 1580	\$ 1831	\$ 1997
36"W	P15036HP <input checked="" type="checkbox"/>	\$ 1319	\$ 1408	\$ 1498	\$ 1724	\$ 1997	\$ 2179
42"W	P15042HP <input checked="" type="checkbox"/>	\$ 1441	\$ 1536	\$ 1637	\$ 1884	\$ 2180	\$ 2379
48"W	P15048HP <input checked="" type="checkbox"/>	\$ 1501	\$ 1603	\$ 1706	\$ 1967	\$ 2276	\$ 2485
60"W	P15060HP	\$ 1720	\$ 1839	\$ 1957	\$ 2260	\$ 2623	\$ 2862
72"W	P15072HP	\$ 2097	\$ 2241	\$ 2384	\$ 2748	\$ 3184	\$ 3473

65"H Tackable Glazed Panel w/15"H Clear Glass							
24"W	P16524HP <input checked="" type="checkbox"/>	\$ 1129	\$ 1211	\$ 1293	\$ 1500	\$ 1751	\$ 1917
30"W	P16530HP <input checked="" type="checkbox"/>	\$ 1215	\$ 1304	\$ 1392	\$ 1617	\$ 1889	\$ 2068
36"W	P16536HP <input checked="" type="checkbox"/>	\$ 1336	\$ 1431	\$ 1531	\$ 1778	\$ 2074	\$ 2271
42"W	P16542HP <input checked="" type="checkbox"/>	\$ 1459	\$ 1564	\$ 1670	\$ 1939	\$ 2264	\$ 2477
48"W	P16548HP	\$ 1524	\$ 1635	\$ 1746	\$ 2028	\$ 2367	\$ 2593
60"W	P16560HP	\$ 1757	\$ 1885	\$ 2016	\$ 2344	\$ 2737	\$ 3001
72"W	P16572HP	\$ 2130	\$ 2286	\$ 2444	\$ 2836	\$ 3311	\$ 3626

65"H Tackable Glazed Panel w/15"H Frosted Glass							
24"W	P16524HP <input checked="" type="checkbox"/>	\$ 1211	\$ 1293	\$ 1375	\$ 1582	\$ 1833	\$ 1999
30"W	P16530HP <input checked="" type="checkbox"/>	\$ 1304	\$ 1393	\$ 1481	\$ 1706	\$ 1978	\$ 2157
36"W	P16536HP <input checked="" type="checkbox"/>	\$ 1431	\$ 1526	\$ 1626	\$ 1873	\$ 2169	\$ 2366
42"W	P16542HP <input checked="" type="checkbox"/>	\$ 1564	\$ 1669	\$ 1775	\$ 2044	\$ 2369	\$ 2582
48"W	P16548HP	\$ 1635	\$ 1746	\$ 1857	\$ 2139	\$ 2478	\$ 2704
60"W	P16560HP	\$ 1885	\$ 2013	\$ 2144	\$ 2472	\$ 2865	\$ 3129
72"W	P16572HP	\$ 2286	\$ 2442	\$ 2600	\$ 2992	\$ 3467	\$ 3782

OPTIMIZE

<p>How to specify — Select the Model Number from above.</p>	<p>1st Option: Panel Fabric <i>(if applicable):</i> See page 10 for fabrics. Limited selection for 72"W models.</p>	<p>2nd Option: Paint: <input checked="" type="checkbox"/> P1 <input checked="" type="checkbox"/> P2 <input checked="" type="checkbox"/> P3 See page 68 for finishes. For P2 paints on stacking and base panels — add \$46. For P3 paints — add \$92.</p>	<p>3rd Option: Glass <i>(if applicable):</i> C Clear F Frosted</p>
--	--	---	--

Examples: P21572G.P7B.F P16524HP.ECH901.P7B.C

Shippable by small-package carrier.

Panels

For specification information see pages 71-75.

GSA SIN 33721

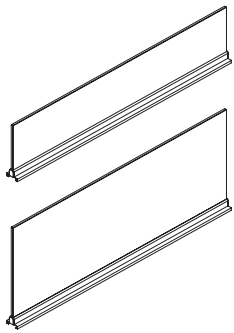

Description and Examples	7½"H Model		15"H Model		7½"H List Price		15"H List Price	
	Model		Model		Clear	Frosted	Clear	Frosted
Glass Panel Mounted Screens — ¾" Thick Glass with Painted Trim (Example spans multiple panels)								
24"W	P2AOP-0724FG	[S]	P2AOP-1524FG	[S]	\$ 692	\$ 744	\$ 785	\$ 843
30"W	P2AOP-0730FG	[S]	P2AOP-1530FG	[S]	\$ 768	\$ 825	\$ 866	\$ 928
36"W	P2AOP-0736FG	[S]	P2AOP-1536FG	[S]	\$ 852	\$ 914	\$ 978	\$ 1049
42"W	P2AOP-0742FG	[S]	P2AOP-1542FG	[S]	\$ 910	\$ 976	\$ 1041	\$ 1118
48"W	P2AOP-0748FG	[S]	P2AOP-1548FG	[S]	\$ 985	\$ 1056	\$ 1145	\$ 1230
54"W – 24" + 30"	P2AOP-0754FG	[S]	P2AOP-1554FG	[S]	\$ 1103	\$ 1184	\$ 1252	\$ 1343
60"W – 30" + 30" or 24" + 36"	P2AOP-0760FG	[S]	P2AOP-1560FG	[S]	\$ 1196	\$ 1285	\$ 1344	\$ 1440
66"W – 30" + 36"	P2AOP-0766FG	[S]	P2AOP-1566FG	[S]	\$ 1329	\$ 1424	\$ 1452	\$ 1559
72"W – 36" + 36" or 24" + 48"	P2AOP-0772FG	[S]	P2AOP-1572FG	[S]	\$ 1409	\$ 1629	\$ 1532	\$ 1645

Note: Frameless glass model change as of 7/1/2021 due to an adjustment in glass height. New glass models are 1" shorter than old models to accommodate variable height conditions. To match old product for reconfiguration purposes, contact the Tailored Products Group.

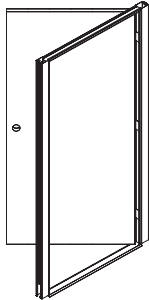

Description	Model	P1 List Price	P2 List Price	P3 List Price
Door Panel — Laminate				
80"H x 42"W Hinged Door without Top Trim	P48042DP	\$ 3818	\$ 3874	\$ 3931
Standard Lockset (Door Knob)	899900	\$ 180	N/A	N/A

Note: Polished Brass; keyed on one side.

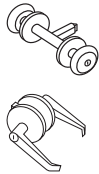

Door Lever	899910	\$ 511	N/A	N/A
------------	--------	--------	-----	-----

Note: Brushed Aluminum; keyed on one side.

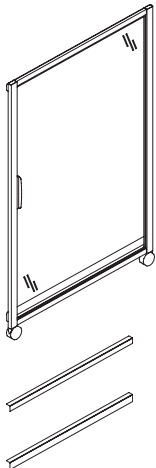

Frosted Translucent Sliding Doors (for 36"W opening)

50"H x 42"W	Z15042SD	\$ 5704	\$ 5766	\$ 5831
65"H x 42"W	Z16542SD	\$ 6914	\$ 6976	\$ 7041
80"H x 42"W	Z18042SD	\$ 8421	\$ 8483	\$ 8548

Mounting Kit for Sliding Doors (mounts to adjacent Optimize panel)

30"W	P1DMK30	[S]	\$ 533	\$ 553	\$ 569
36"W	P1DMK36	[S]	\$ 533	\$ 553	\$ 569
42"W	P1DMK42	[S]	\$ 533	\$ 553	\$ 569
48"W	P1DMK48	[S]	\$ 533	\$ 553	\$ 569







<p>How to specify — Select the Model Number from above.</p>	<p><i>1st Option:</i> Paint: P1 P2 P3 See page 68 for finishes.</p>	<p><i>2nd Option:</i> Glass — Screen Only (if applicable): C Clear F Frosted</p>	<p><i>2nd Option:</i> Laminate — Door Only (if applicable): See page 68 for finishes.</p>	<p><i>2nd Option:</i> Insert — Sliding Door Only (if applicable): FT Frosted Translucent</p>																																																		
<table border="1" style="width: 100%; height: 20px;"> <tr> <td style="width: 12.5%;"></td> <td style="width: 12.5%;"></td> <td style="width: 12.5%;"></td> <td style="width: 12.5%;"></td> <td style="width: 12.5%;"></td> <td style="width: 12.5%;"></td> <td style="width: 12.5%;"></td> <td style="width: 12.5%;"></td> <td style="width: 12.5%;"></td> <td style="width: 12.5%;"></td> </tr> </table>											<table border="1" style="width: 100%; height: 20px;"> <tr> <td style="width: 12.5%;"></td> <td style="width: 12.5%;"></td> <td style="width: 12.5%;"></td> <td style="width: 12.5%;"></td> <td style="width: 12.5%;"></td> <td style="width: 12.5%;"></td> <td style="width: 12.5%;"></td> <td style="width: 12.5%;"></td> <td style="width: 12.5%;"></td> <td style="width: 12.5%;"></td> </tr> </table>											<table border="1" style="width: 100%; height: 20px;"> <tr> <td style="width: 12.5%;"></td> <td style="width: 12.5%;"></td> <td style="width: 12.5%;"></td> <td style="width: 12.5%;"></td> <td style="width: 12.5%;"></td> <td style="width: 12.5%;"></td> <td style="width: 12.5%;"></td> <td style="width: 12.5%;"></td> <td style="width: 12.5%;"></td> <td style="width: 12.5%;"></td> </tr> </table>											<table border="1" style="width: 100%; height: 20px;"> <tr> <td style="width: 12.5%;"></td> <td style="width: 12.5%;"></td> <td style="width: 12.5%;"></td> <td style="width: 12.5%;"></td> <td style="width: 12.5%;"></td> <td style="width: 12.5%;"></td> <td style="width: 12.5%;"></td> <td style="width: 12.5%;"></td> <td style="width: 12.5%;"></td> <td style="width: 12.5%;"></td> </tr> </table>											<table border="1" style="width: 100%; height: 20px;"> <tr> <td style="width: 12.5%;"></td> <td style="width: 12.5%;"></td> <td style="width: 12.5%;"></td> <td style="width: 12.5%;"></td> <td style="width: 12.5%;"></td> <td style="width: 12.5%;"></td> <td style="width: 12.5%;"></td> <td style="width: 12.5%;"></td> <td style="width: 12.5%;"></td> <td style="width: 12.5%;"></td> </tr> </table>										

Examples: P20720GS.P02.F Z15042SD.P02.FT P1DMK36.P02

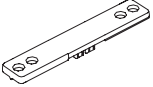
[S] Shippable by small-package carrier.

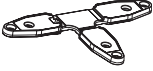
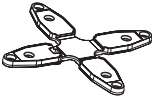
For specification information see pages 71-75.

GSA SIN 33721

	Description	Model	List Price
	In-line Connector Kits		
	Single Connector Strap and Hardware	P3CONTT S	\$ 110
	Connector Straps		
	Single Connector Strap	P3CONS1	\$ 24
	"L" Connector Strap	P3CONSL	\$ 24
	"T" Connector Strap	P3CONST	\$ 31
	"X" Connector Strap	P3CONSX	\$ 41
	Extended Straight Connector Strap "S"	P3CONSS	\$ 41
	120 Degree 2 Way Connector Strap "V"	P3CONSV	\$ 54
	120 Degree 3 Way Connector Strap "Y"	P3CONSY	\$ 54

How to specify —

Select the Model Number from above.

P | 3 | C | O | N | | | |

Example: P3CONTT

S Shippable by small-package carrier.

For specification information see pages 71-75.

GSA SIN 33721



Description	Model	P1 List Price	P2 List Price	P3 List Price
Connector Posts				
"L" 90° Connector Post				
35"H "L" Connector Post	P3CONL35N	\$ 144	\$ 169	\$ 191
42½"H "L" Connector Post	P3CONL42N	\$ 144	\$ 169	\$ 191
50"H "L" Connector Post	P3CONL50N	\$ 181	\$ 206	\$ 228
57½"H "L" Connector Post	P3CONL57N	\$ 181	\$ 206	\$ 228
65"H "L" Connector Post	P3CONL65N	\$ 181	\$ 206	\$ 228
72½"H "L" Connector Post	P3CONL72N	\$ 211	\$ 236	\$ 258
80"H "L" Connector Post	P3CONL80N	\$ 211	\$ 236	\$ 258
"T" 3-Way Connector Post				
35"H "T" Connector Post	P3CONT35N	\$ 270	\$ 287	\$ 299
42½"H "T" Connector Post	P3CONT42N	\$ 270	\$ 287	\$ 299
50"H "T" Connector Post	P3CONT50N	\$ 295	\$ 312	\$ 324
57½"H "T" Connector Post	P3CONT57N	\$ 295	\$ 312	\$ 324
65"H "T" Connector Post	P3CONT65N	\$ 295	\$ 312	\$ 324
72½"H "T" Connector Post	P3CONT72N	\$ 364	\$ 381	\$ 393
80"H "T" Connector Post	P3CONT80N	\$ 364	\$ 381	\$ 393
"X" 4-Way Connector Post				
35"H "X" Connector Post	P3CONX35N	\$ 260	\$ 277	\$ 289
42½"H "X" Connector Post	P3CONX42N	\$ 260	\$ 277	\$ 289
50"H "X" Connector Post	P3CONX50N	\$ 285	\$ 302	\$ 314
57½"H "X" Connector Post	P3CONX57N	\$ 285	\$ 302	\$ 314
65"H "X" Connector Post	P3CONX65N	\$ 285	\$ 302	\$ 314
72½"H "X" Connector Post	P3CONX72N	\$ 354	\$ 371	\$ 383
80"H "X" Connector Post	P3CONX80N	\$ 354	\$ 371	\$ 383
"S" Extended Straight Connector Post				
35"H Extended Straight Connector Post "S"	P3CONS35N	\$ 396	\$ 413	\$ 425
42½"H Extended Straight Connector Post "S"	P3CONS42N	\$ 396	\$ 413	\$ 425
50"H Extended Straight Connector Post "S"	P3CONS50N	\$ 489	\$ 506	\$ 518
57½"H Extended Straight Connector Post "S"	P3CONS57N	\$ 489	\$ 506	\$ 518
65"H Extended Straight Connector Post "S"	P3CONS65N	\$ 489	\$ 506	\$ 518
72½"H Extended Straight Connector Post "S"	P3CONS72N	\$ 618	\$ 635	\$ 647
80"H Extended Straight Connector Post "S"	P3CONS80N	\$ 618	\$ 635	\$ 647

How to specify —
Select the
Model Number
from above.

1st Option:

Paint
(if applicable):



See page 68
for finishes.

P 3 C O N | | | | | . | | | | |

Example: P3CONL35N.P02

For specification information see pages 71-75.

GSA SIN 33721



Description	Model	P1 List Price	P2 List Price	P3 List Price
Panel End Trim				
35"H	P3AOP-ET35	\$ 115	\$ 140	\$ 162
42½"H	P3AOP-ET42	\$ 115	\$ 140	\$ 162
50"H	P3AOP-ET50	\$ 120	\$ 145	\$ 167
57½"H	P3AOP-ET57	\$ 120	\$ 145	\$ 167
65"H	P3AOP-ET65	\$ 120	\$ 145	\$ 167
72½"H	P3AOP-ET72	\$ 150	\$ 175	\$ 197
80"H	P3AOP-ET80	\$ 150	\$ 175	\$ 197
Variable Height Connector Kit — Post Trim				
7½"H	P3AOP-VH07	\$ 111	\$ 136	\$ 158
15"H	P3AOP-VH15	\$ 111	\$ 136	\$ 158
22½"H	P3AOP-VH22	\$ 122	\$ 147	\$ 169
30"H	P3AOP-VH30	\$ 122	\$ 147	\$ 169
In-line Variable Height End Trim Finish Kit				
7½"H	P3AOP-IV07	\$ 111	\$ 136	\$ 158
15"H	P3AOP-IV15	\$ 111	\$ 136	\$ 158
22½"H	P3AOP-IV22	\$ 122	\$ 147	\$ 169
30"H	P3AOP-IV30	\$ 122	\$ 147	\$ 169
Grooved Variable Height Finish Kit				
7½"H	P3AOP-GV07	\$ 113	\$ 138	\$ 160
15"H	P3AOP-GV15	\$ 123	\$ 148	\$ 170
Wall Mount Kit				
35"H	P3AOP-WM35	\$ 246	\$ 271	\$ 293
42½"H	P3AOP-WM42	\$ 246	\$ 271	\$ 293
50"H	P3AOP-WM50	\$ 268	\$ 293	\$ 315
57½"H	P3AOP-WM57	\$ 268	\$ 293	\$ 315
65"H	P3AOP-WM65	\$ 268	\$ 293	\$ 315
72½"H	P3AOP-WM72	\$ 330	\$ 355	\$ 377
80"H	P3AOP-WM80	\$ 330	\$ 355	\$ 377
2-Way 120° Connector Post				
35"H 120 Degree 2 Way Connector Post "V"	P3CONB35N	\$ 245	\$ 261	\$ 272
42½"H 120 Degree 2 Way Connector Post "V"	P3CONB42N	\$ 245	\$ 261	\$ 272
50"H 120 Degree 2 Way Connector Post "V"	P3CONB50N	\$ 260	\$ 276	\$ 287
57½"H 120 Degree 2 Way Connector Post "V"	P3CONB57N	\$ 270	\$ 286	\$ 297
65"H 120 Degree 2 Way Connector Post "V"	P3CONB65N	\$ 270	\$ 286	\$ 297
72½"H 120 Degree 2 Way Connector Post "V"	P3CONB72N	\$ 336	\$ 352	\$ 363
80"H 120 Degree 2 Way Connector Post "V"	P3CONB80N	\$ 336	\$ 352	\$ 363
3-Way 120° Connector Post				
35"H 120 Degree 3 Way Connector Post "Y"	P3CONC35N	\$ 245	\$ 261	\$ 272
42½"H 120 Degree 3 Way Connector Post "Y"	P3CONC42N	\$ 245	\$ 261	\$ 272
50"H 120 Degree 3 Way Connector Post "Y"	P3CONC50N	\$ 260	\$ 276	\$ 287
57½"H 120 Degree 3 Way Connector Post "Y"	P3CONC57N	\$ 270	\$ 286	\$ 297
65"H 120 Degree 3 Way Connector Post "Y"	P3CONC65N	\$ 270	\$ 286	\$ 297
72½"H 120 Degree 3 Way Connector Post "Y"	P3CONC72N	\$ 336	\$ 352	\$ 363
80"H 120 Degree 3 Way Connector Post "Y"	P3CONC80N	\$ 336	\$ 352	\$ 363

How to specify —
Select the
Model Number
from above.

1st Option:
Paint
(if applicable):
P1 P2 P3
See page 68
for finishes.

P 3 | | | | | | | | | | . | | | | | | | | | |

Examples: P3AOP-ET35.P02 P3CONB35N.P02

Optimize features capabilities for cable management, including electrical, voice, and data. The 8-wire electrical system can be integrated at base pathway. The frame allows voice and data cables to be routed horizontally in the base pathway.

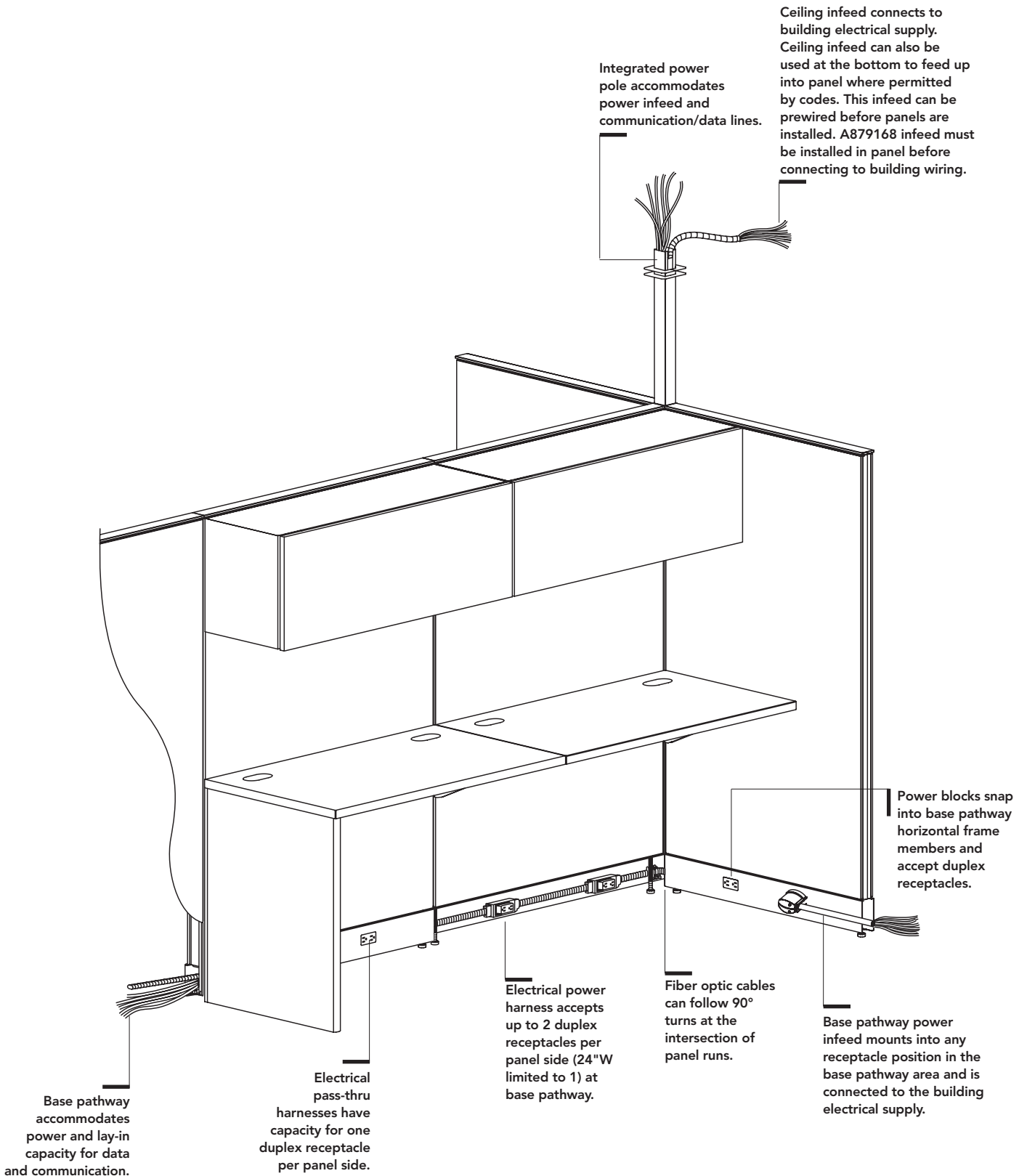

OPTIMIZE

Electrical Systems

Optimize Electrical Systems

Optimize offers a choice of four electrical systems:

- Four-circuit, 3 + 1
- Four-circuit, 2 + 2
- Three-circuit, separate neutrals
- Eight circuits; two four-circuit systems provided back-to-back.
- See pages 85-86 for a detailed explanation of each electrical system.
- All four systems utilize an 8-wire electrical system, rated at 20 amps per circuit (15 amps Canadian).
- Optimize panels and electrical components are UL Listed. Electrical components are also CSA certified.
- Installation and use of the electrical system, the number of receptacles used on a given circuit, and connections to the building power supply should be in compliance with all local and national electrical codes.

Caution: Electrical equipment cords or extension cords MUST NOT BE ROUTED through panels.

Hardwire Junction Box – New York Code (page 93)

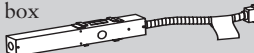
- Hardwire (New York Code) junction box (model A871400) is used when local electrical codes require hardwire entry. 
- For use in panels 30" W to 72" W.
- When used in 30" W and 36" W panels, power can be routed only in one direction.
- When used in 42" and wider panels, an electrical pass-thru cable or harness for that panel width can be used to route power back in the opposite direction.
- Unit must connect to a power or pass-thru harness positioned in the base pathway area of an adjacent panel.
- Customer to furnish all cabling and wiring from power entry to power source.
- Junction box can be positioned at any duplex receptacle location.

Hardwire Wiring Harness – Chicago Code (page 93)

- Hardwire (Chicago Code) wiring harnesses and snap connectors are not allowed in Chicago — base pathways must be comprised of all metallic components.
- The base pathway junction box (model A871500) clips direct into receptacle locations for single sided applications.
- Customer must furnish conduit, wiring, and designer-type receptacles for the base pathway.
- Power entry can be routed from the ceiling, via an Optimize power pole, or from the floor into a junction box (model A871500).

Electrical Infeeds

- Power infeed cables deliver power from building to panel's electrical system.
- Infeed cables are housed in conduit to separate electrical system from communications and data lines.
- Select quantity of base or ceiling infeed cables depending on individual power requirements.

Base Pathway Power Infeed (page 93)

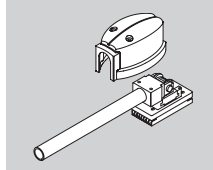
- Sealtight base pathway power infeed mounts into any receptacle position in the base pathway area.
- A heavy rubber sheathing shields conduit, allowing infeed to be exposed. 

Ceiling Power Infeed (page 93)

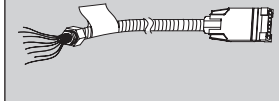
- Ceiling power infeed connects to a prewired electrical harness in the base pathway, traverses through an adjacent panel, and terminates in the junction box at the top of the integrated power pole. 
- Use integrated power pole model P278PP.
- Most codes allow flex conduit to be exposed after installation. Verify code requirements before ordering for exposed application.

Integrated Power/Communication Pole (page 93)

- Integrated power pole accommodates ceiling power infeed and communication/data lines.
- Provide capacity for routing power infeed and cables to the base pathway of a panel.
- Conduit of the infeed cable serves as the division of electrical and communications cabling.
- Installs into 42½"-65" H or 15" H stacking 90°, "T", and "X" connections.
- Integrated power pole includes trim kit.
- Single cavity with removable cover.
- Field-cut to desired length.
- Outside Dimension: 2" square.
- When using a ceiling power infeed, consider that the infeed must connect into an electrical harness located in an adjacent panel. (See page 90 for cable capacity.)
- To power the prewired electrical system, from a ceiling power source, a ceiling infeed cable, Model A871912, A871912C, A871912A, A871912AC, A871918, A871918C, A871918A, or A871918AC must be purchased separately.
- For applications requiring longer integrated power poles, a 156" H model is available.

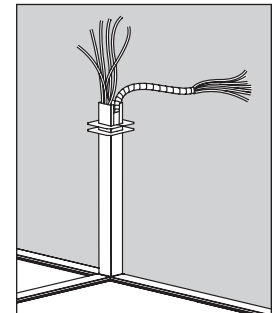

Integrated Power and Communications Pole

To Order:

- Determine which electrical system you will use after consulting your electrician and computer support personnel:
 - The four-circuit system (4-Hot/2-Neutral/2-Ground)
 - 3 + 1 option
 - 2 + 2 option
 - The three-circuit system (3-Hot/3-Neutral/2-Ground)
 - The eight-circuit system (back-to-back four-circuit systems)
- Determine location, quantity, and circuit of duplexes.
- Determine the appropriate choice and use of isolated, isolated/dedicated, and separate neutrals circuits.
- Specify appropriate power harnesses* and pass-thru cables.*
- Determine the location, quantity, and type of power infeed needed.

* Select power harness models (A8712XX), pass-thru cables (A8710XX), and pass-thru harness (A8711XX) with the last two digits corresponding with the panel width into which the component is to be positioned. The initial cable length can be stretched approximately 3" to transverse "T", "X", "L", and extended straight connectors.

Flexconnect™ Electrical System Options

The four-circuit, eight-wire electrical system is widely specified and trusted by hundreds of thousands of end-users. This proven system delivers four circuits for every power infeed in either a 3 + 1 or 2 + 2 configuration. The isolated/dedicated circuits are ideal for sensitive computing equipment, while the common circuits are suitable for faxes, copiers, task lights and other peripherals. Both the 3 + 1 and 2 + 2 systems use the same pre-wired components, making it easy to adjust as electrical needs change.

You can also choose a three-circuit, eight-wire system that has a dedicated neutral for every hot circuit. The three-circuit components have model numbers with an "A" suffix and appear in a gray box in this price.

All three systems utilize an eight-wire electrical system rated at 20 amps per circuit (15 amps Canadian). Concensys panels and electrical components are UL listed and CSA certified.

Reference the Office Equipment Typical Load Values matrix on page 91.

Four-circuit, 3 + 1 Receptacle Option

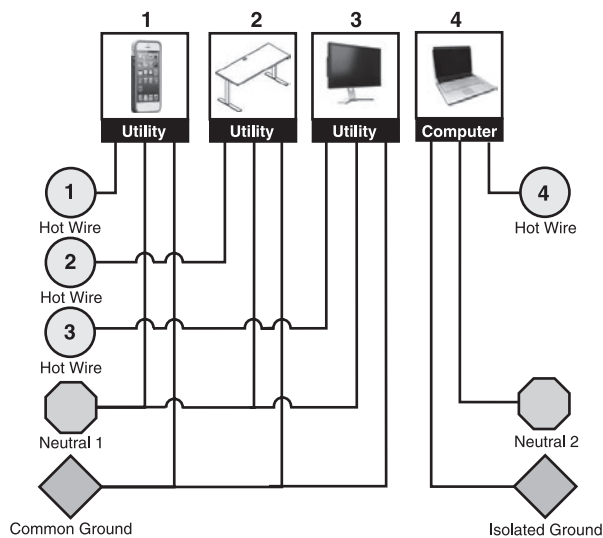

The 3 + 1 option is the electrical standard used on Allsteel systems for many years in most installations. This wiring option provides three utility circuits plus an isolated/dedicated circuit for more sensitive equipment. Circuit 2 (one of the 3 common circuits sharing a neutral wire) cannot be used with single-phase building electrical supply.

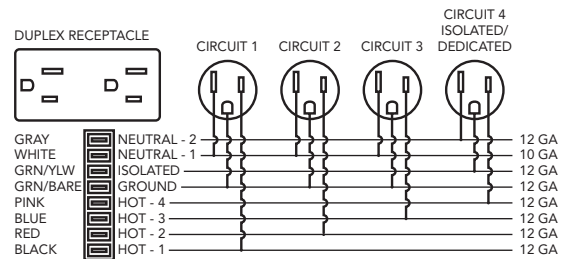

Four-circuit, 2 + 2 Receptacle Option

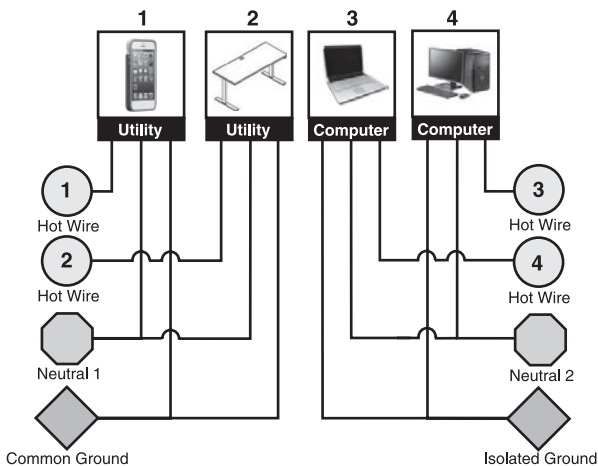

The 2 + 2 option is a wiring option that provides two utility circuits and two isolated circuits for more extensive computer usage applications.

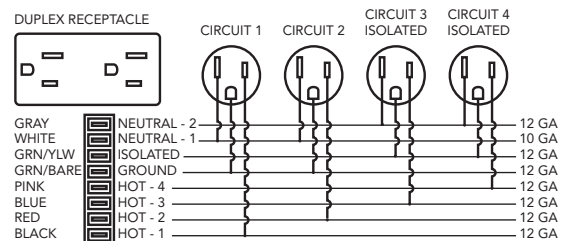

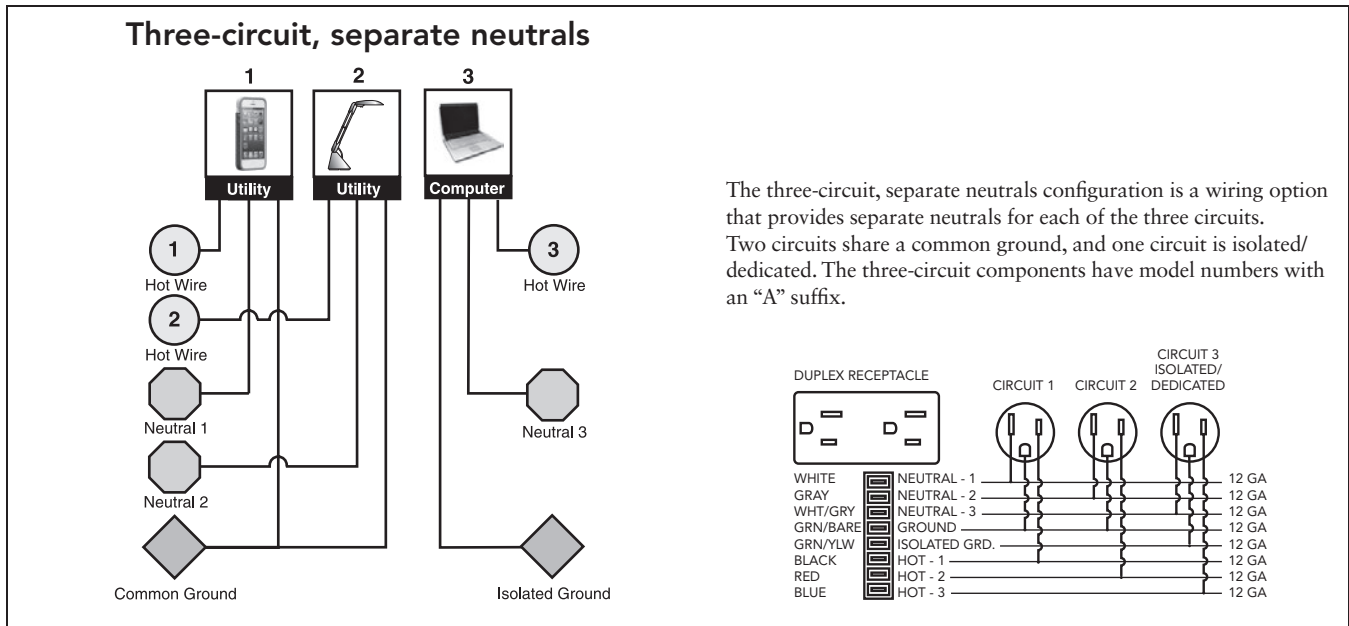

Optimize System Receptacle Usage					
Two 8-wire, 20 amp (15 amp Canadian) electrical systems are offered					
Electrical System	Circuitry	Receptacle Capacity			
Four-circuit 4-Hot/2-Neutral/2-Ground	3 + 1	Common Circuit-1 A871501	Common Circuit-2 ⁽¹⁾ A871502	Common Circuit-3 A871503	Iso/Dedicated Circuit-4 A871504
	2 + 2	Common Circuit-1 A871501	Common Circuit-2 A871502	Isolated Circuit-3 A871506	Isolated Circuit-4 A871504
Three-circuit 3-Hot/3-Neutral/2-Ground	w/separate neutrals	Common Circuit-1 A871501A	Common Circuit-2 A871502A	Iso/Dedicated Circuit-3 A871503A	N/A

(1) Circuit 2 (one of the 3 common circuits sharing a neutral wire) cannot be used with a single-phase building electrical supply.

Notes:

- Four-circuit components and three-circuit components (with suffix “A”) cannot be used together.
- Components of the two systems are keyed differently to prevent components of one system being connected to components of another system.
- Allsteel Model Numbers are printed on the UL labels, and components are color-coded to provide visual identification of the different components.
- Four-circuit components have black plastic parts.
- Three-circuit components have rust-colored terminal ends and receptacle backs are rust colored.

Duplex Receptacle



15 amp Receptacle

Power Harnesses, Pass-Thru Harnesses, and Dual Electrical Harnesses

Electrical power harnesses are used to distribute power in Optimize panels. Harness power blocks snap directly onto brackets in base pathway. Power blocks on electrical power harness and pass-thru harness accept duplex receptacles.

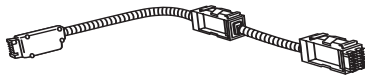
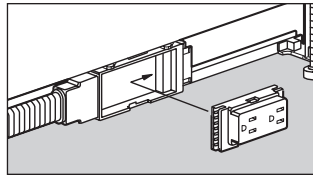

Electrical Power Harness

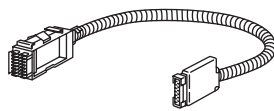

Electrical Pass-Thru Harness With Power Block

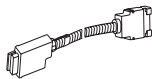

Electrical Pass-Thru Harness Without Power Block

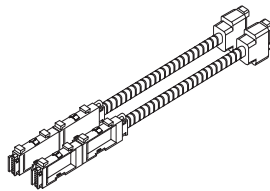

Dual Electrical Eight-circuit Power Harness Kit

All electrical power harnesses and pass-thru harnesses (except 20"W) will stretch 3½", allowing them to span "T", "X", "120" intersections, and "S" extended straight connections.

Note: "T" intersections require a minimum of one power harness and "X" intersections requires a minimum of two power harnesses.

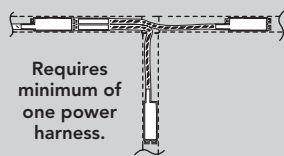

Requires minimum of one power harness.

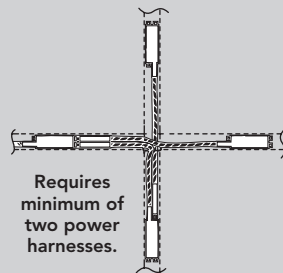

Requires minimum of two power harnesses.

Use of a ceiling infeed at this location requires an additional power harness.

Electrical Power Harnesses (page 92)

- Electrical power harnesses are used to distribute power in panels.
- Optimize electrical can only be located at base pathway.
- Specify harness length to match panel width.
- 24" power harness accepts one receptacle on each side of the harness, all other length power harnesses have power blocks to accept four duplex receptacles (two on each side of panel).
- Connectors at both ends of power harnesses allow power distribution in either direction.
- Harness power blocks snap directly onto brackets in base pathway.
- Use of a ceiling infeed requires one additional harness.

Electrical Pass-thru Harness With Power Block (page 92)

- Electrical pass-thru harness with power block have capacity to handle one duplex receptacle on each side of the panel when exposed.
- Specify harness length to match panel width or combined panel widths.
- Power harnesses accept one duplex receptacle per panel side.
- Note: "T" intersections require a minimum of one power harness and "X" intersections requires a minimum of two power harnesses.
- All electrical power harnesses and pass-thru harnesses with power block will stretch 3½", allowing them to span "T", "X", "A" intersections, and "S" extended straight connections.

Electrical Pass-thru Harnesses Without Power Block (page 92)

- Specify harness length to match panel width or combined panel widths.
- Electrical pass-thru cables distribute power through any panel(s) where receptacles are not required. Cable length cannot be stretched.

Dual Electrical Eight-Circuit Power Harness Kits (page 92)

- Kit provides back-to-back four-circuit systems giving double the capacity of harness and pass-thru cables.
- Specify harness length to match panel width.
- Requires two four-circuit infeeds.
- Uses four-circuit receptacles.
- Models must be positioned back-to-back in the panel — single-side use is not permitted.
- Components can only be routed in a single run — a single run can branch to single panel runs at "T" and "X" junctions.
- Standard four-circuit pass-thru cables (A8710xx) can be used in between power harnesses. Two are required in the back-to-back configurations.
- Models can be connected to standard four-circuit power harnesses and pass-thrus, although it is not recommended because of possible circuit number ambiguity.
- Two power infeeds are required to connect the back-to-back runs. Power A8719xx must be connector to a power block at the end of a run.
- Data faceplates and terminals cannot be positioned in a panel into which back-to-back power harnesses are installed
- Power infeeds A8719xx must be routed from a panel wherein no power harness is positioned, into an adjacent panel where a power harness is positioned and connected to the end of a power block.

Receptacles

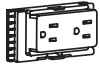

Duplex Receptacle

Receptacle Color Recommended to Coordinate with Paint Color

Paint Color	Receptacle Color
Designer White — PJW	Designer White — DW
Bungalow — P7C	Muslin — EU
Carob — P52	Black — E4
Champagne Metallic — PR5	Muslin — EU
Cinder — P7Q	Brownstone — EY
Fossil — P28	Flint — E9
Gunmetal Metallic — PR3	Brownstone — EY
Parchment — P93	Muslin — EU
Pebble — P8R	Loft — EV
Pewter — P8D	Flint — E9
Platinum Metallic — PR2	Loft — EV
Salt — P8C	Silver — ES
Titanium — P8T	Silver — ES

Duplex Receptacles (page 93)

- Duplex receptacles snap into power blocks of power harnesses or pass-through harnesses with blocks.
- Duplexes are available in multiple colors. See page 68 for finishes.
- Each receptacle is labeled to indicate which circuit it will be connected to: 1, 2, 3, or 4.
- Duplexes are model specific to support either 3+1 and 2+2 electrical infeed; or have an "A" suffix and are design to support a three-circuit separate neutral electrical infeed.

Data Components

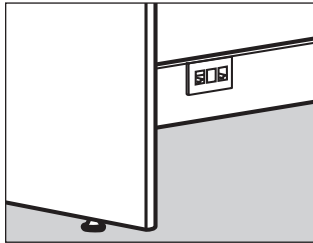

Voice/Data Receptacles

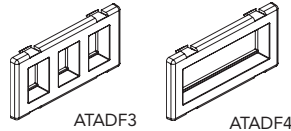

ATADF3

ATADF4

Data Faceplates (page 94)

- Optimize not only provides space for large volumes of voice and data cables, it also offers several means of mounting commercially available voice and data components.
- Commercially available modular data faceplates can be mounted in vacant base receptacle openings.
- Due to panel depth, back-to-back data modules should not be used at the base on Optimize.

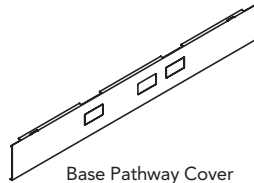

Base Pathway Cover

Optimize Base Pathway Covers (page 94)

- Features an additional knockout (offset) for improved utilization of power and data. Knockouts are 2.700" W x 1.377" H up to 60" W.
- Due to panel depth, back-to-back data modules should not be used in the base on Optimize.

Cable and Wire Management

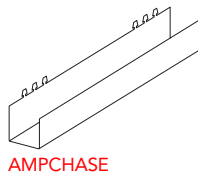
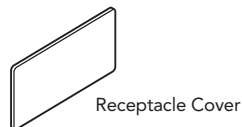
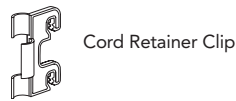
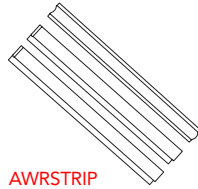
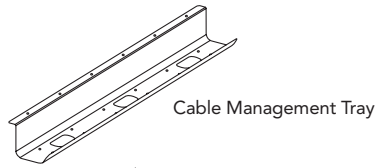

Cable Management Tray (page 94)

- Attaches under the worksurface to contain cables.
- Metal tray shelf is 4" deep. Can hold electrical power strip and/or surge protector.
- 24" and 36" lengths, use multiple units for larger worksurfaces.
- Attachment hardware included, paint option is black only.
- Zip tie attachment points located in base of tray. Zip ties not included.

Wire Management Strips/Channels (page 94)

- Self adhesive backing to attach to panels and underside of worksurfaces.
- Flexible strips allow cabling to enter/exit and can be contained inside the strips' cavities.
- Includes two wire management profiles. Smaller profile allows for qty. 3, .3" diameter cords, has area of .32 in². Larger "J" shaped profile allows for qty. 10, .3" diameter cords, has area of 1.14 in².

Cord Retainer Clip (page 94)

- Provides confinement of vertical electrical/data wiring.
- 1½"H cord clips snap into vertical panel slots to contain cords.
- 4 clips are provided standard with each task light cord.
- Package of 50. Available in Black only.

Wireway Grommet (page 94)

- Fits into any receptacle opening.
- Used when routing wires through receptacle opening.

Replacement Receptacle Cover (page 94)

- Fits into unused receptacle opening in base raceway.
- Package of 25. Specify paint color.

Cord Organizer (page 94)

- Attaches to bottom of worksurface.
- 4"W x ⅞"D, made from sheet metal.
- Top sits flush with worksurface if mounted to worksurface.
- 4 cable cut outs: 2 – .250" diameter and 2 – 0.147" diameter; .250" diameter cut outs are centered between the .147" diameter cut outs.

Panel Mounted Wire Chase (page 94)

- Attaches between panels on Stride, Terrace, and Optimize via a slotted standard.
- Designed to sit below a worksurface and provide additional cord management from the base rail to beltline/under-worksurface height.
- Available in standard metal paint finishes.

Lighting

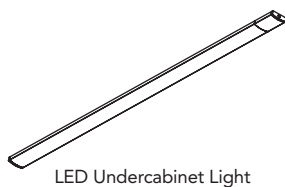
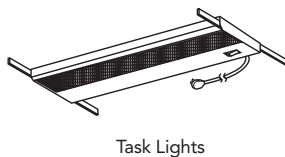

Task Lights (page 295)

- Task lights can be recessed under storage cabinets or storage shelves, panel-hung, or freestanding.
- Three styles of recessed task lights in four sizes are available to correspond to cabinet or shelf width.
- All styles have 9' power cords in black, connected in the right rear corner.
- All models feature electronic ballast for longer bulb life and cooler operating temperature.
- Task lights with a fused plug to meet Chicago electrical code are also available.

Recommendation: Provide a separate circuit for task lights for proper long-term operation without RF interference to computers that may be in use.

LED Undercabinet Light (page 295)

- LED undercabinet light can be mounted beneath overhead cabinets with wood screws or magnets.

For more power and wire management options, please visit the Extensions pages.

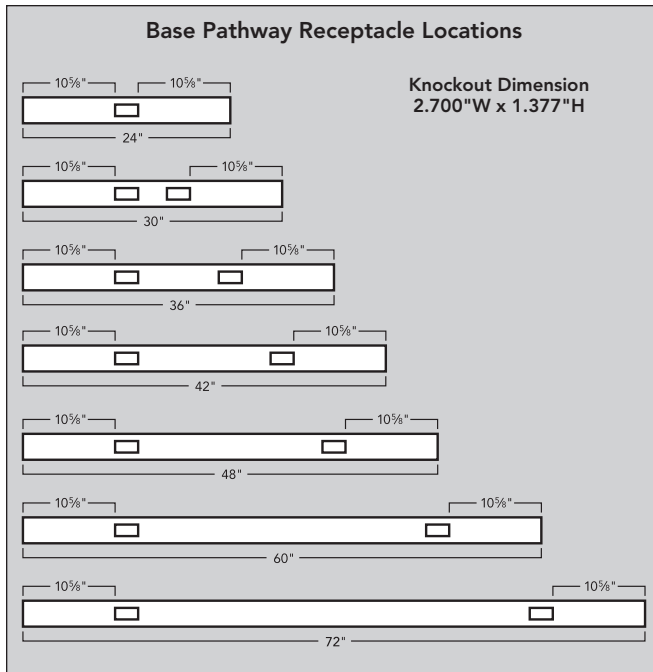

Circuit Usage

Strategy 1

Circuits to Equipment

Assign specific uses for each of the circuits:

- For example, in a four-circuit system:
 - Circuit 1 — Calculators, fans, etc.
 - Circuit 2 — Task lights (could be wired to wall switch)
 - Circuit 3 — CRT or flat screen monitors
 - Circuit 4 — CPUs

Strategy 2

Circuits to Workstations

Assign specific workstations to each of the three available circuits. Use circuit 4 for power-sensitive electronic equipment.

Placement of pedestals and lateral files may render some duplex locations inaccessible. Pedestal placement may also affect compatibility with pull-up receptacles.

Lay-in Cable Capacity

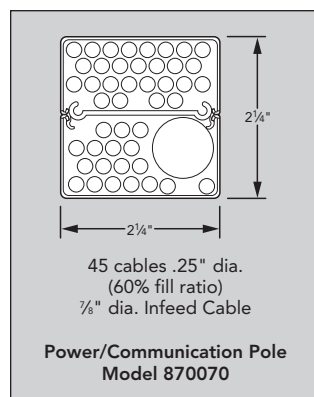
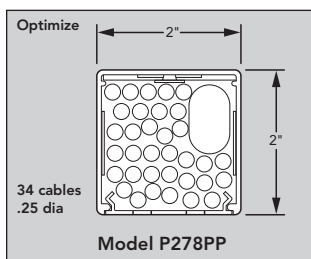
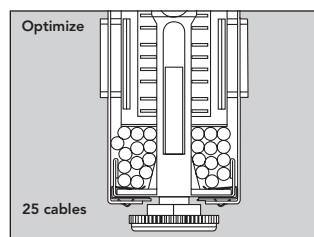
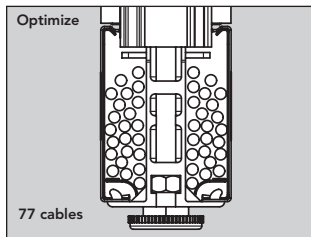

- The base pathway allows continuous voice and data lines to run through and between panels without interruption.
- Lay-in is provided for environments where systems furniture or cabling are subject to frequent change.
- Optimize base pathway accepts up to 77 voice/data cables (.25" dia.) (6.27 sq. in.) at 60% fill.
- When electrical system shares base pathway, the cable capacity in Optimize is reduced to 25 cables (2.03 sq. in.).
- Cable capacity of the Optimize integrated power pole is 3.3 sq. in. for a total capacity of 34 cables of .25" diameter.
- Cable capacity of the power pole/communication pole Model A870070 is 4.5 sq. in.
- Cables can enter/exit panel through underside of base pathway on frames.

Note: Cable quantities listed are at 60% fill ratio.

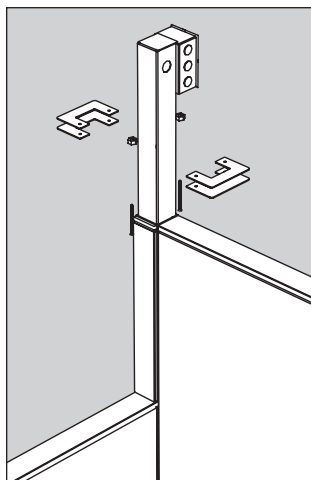

OPTIMIZE

Office Equipment Typical Load Values

Item	*Amps
Desktop/2 Monitors	4
Laptop Computer	1
Laptop/2 Monitors/Docking Station	3
Paper Shredder	1.22
Radio	0.05
Scanner	3
Space Heater (1500 watts)	12
Task Light (equiv. 60-watt bulb)	
Fluorescent	0.12
LED	0.08
USB Charger	0.17
LCD Television (42")	1
LCD Monitor (21")	0.5
Bluetooth Speaker	0.1
Desktop Printer	
Inkjet	0.15
Laser	4 to 10
Multimedia Projector	1.7
Sit-to-Stand Height-Adjustable Desk	Idle 0.01 / Max 4
Office Kitchen	
Coffee Maker	10
Microwave	10
Toaster	12.5
Compact Refrigerator	1.5

*Chart is recommended for planning purposes. Check device specifications for exact amperage. Consult with your electrician regarding the applicable configurations.

Examples of Component Usage based on the *Office Equipment Typical Load Values Chart*

Power Option 3+1

Dedicated Circuit 4: 4 desktop computers with 2 monitors each; or 10 laptop computers
Utility Circuits 1, 2, 3: Height-adjustable tables and ancillary items

Power Option 2+2

Dedicated Circuit 3: 4 desktop computers with 2 monitors each; or 10 laptop computers
Dedicated Circuit 4: 4 desktop computers with 2 monitors each; or 10 laptop computers
Utility Circuits 1, 2: Height-adjustable tables and ancillary items

Power Option 3 (Circuit-separate neutrals)

Dedicated Circuit 3: 4 desktop computers with 2 monitors each; or 10 laptop computers
Utility Circuits 1, 2: Height-adjustable tables and ancillary items

For specification information see pages 83-91.

GSA SIN 33721

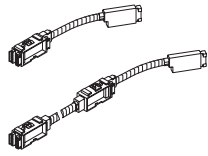

Description	Max. Recept. Cap. per Panel Side	Four-circuit 3 + 1 2 + 2	Three-circuit Separate Neutrals	List Price
Electrical Power Harnesses				
For 24" W Panels	1	A871224	A871224A	\$ 391
For 30" W Panels	2	A871230	A871230A	\$ 391
For 36" W Panels	2	A871236*†	A871236A	\$ 391
For 42" W Panels	2	A871242*	A871242A	\$ 416
For 48" W Panels	2	A871248*	A871248A	\$ 416
For 60" W Panels	2	A871260*	A871260A	\$ 416
For 72" W Panels	2	A871272*	A871272A	\$ 417

†When purchased separately without a configurable TAA compliant end product, not on GSA contract.

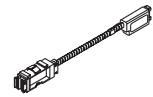

Electrical Pass-Thru Harnesses with Power Block				
For 24" W Panels	1	A871124	A871124A	\$ 239
For 30" W Panels	1	A871130	A871130A	\$ 239
For 36" W Panels	1	A871136*†	A871136A	\$ 239
For 42" W Panels	1	A871142*†	A871142A	\$ 255
For 48" W Panels	1	A871148*†	A871148A	\$ 255
For 60" W Panels	1	A871160*	A871160A	\$ 255
For 72" W Panel Runs	1	A871172	A871172A	\$ 341

Electrical harnesses are intended for use with Allsteel systems furniture and are approved under GSA SIN 33721. When purchased separately and used without Allsteel systems furniture, those electrical harnesses marked by () are considered Open Market.

†When purchased separately without a configurable TAA compliant end product, not on GSA contract.



Electrical Pass-Thru Cable without Power Block				
For 24" W Panels	0	A871024	A871024A	\$ 219
For 30" W Panels	0	A871030	A871030A	\$ 219
For 36" W Panels	0	A871036	A871036A	\$ 219
For 42" W Panels	0	A871042	A871042A	\$ 229
For 48" W Panels	0	A871048	A871048A	\$ 229
For 60" W Panels	0	A871060	A871060A	\$ 229

Note: Four-circuit components and three-circuit components (with an "A" suffix) cannot be connected together.

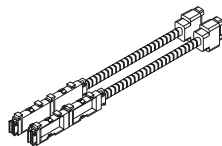

Description	Max. Recept. Cap. per Panel Side	Eight-circuit 3 + 1 (each side) 2 + 2 (each side)	List Price
Dual Electrical Eight-circuit Power Harness Kit			
For 24" W Panels	1	A2-8CIR24	\$ 939
For 30" W Panels	2	A2-8CIR30	\$ 939
For 36" W Panels	2	A2-8CIR36	\$ 1358
For 42" W Panels	2	A2-8CIR42	\$ 1358
For 48" W Panels	2	A2-8CIR48	\$ 1358
For 60" W Panels	2	A2-8CIR60	\$ 1369
For 72" W Panels	2	A2-8CIR72	\$ 1369

Note: Kit consists of two four-circuit harnesses placed "back-to-back" to provide 8 circuits.

OPTIMIZE

<p>How to specify — Select the Model Number from above.</p>	<p><i>1st Option:</i> Color: P Black</p>
--	---

P

Examples: A871224.P A871224A.P A2-8CIR36.P

Shippable by small-package carrier.

For specification information see pages 83-91.

GSA SIN 33721



Duplex Receptacle

Description	Four-circuit 3 + 1 2 + 2	Three-circuit Separate Neutrals	List Price
Duplex Receptacles for Optimize Base Pathway (specify color)			
Circuit 1	A871501	A871501A [S]	\$ 72
Circuit 2	A871502	A871502A [S]	\$ 72
Circuit 3 (3+1)	A871503	A871503A [S]	\$ 72
Circuit 3 (2+2)	A871506	N/A [S]	\$ 72
Circuit 4 — iso/dedicated	A871504	N/A [S]	\$ 72
Circuit 1, 20 AMP	A871601	A871601A [S]	\$ 72

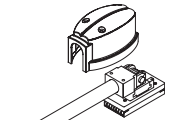

Electrical Infeed Cables

Electrical Infeed Cables			
6' Sealtight Cable for Optimize Receptacle	A879072	A879072A [S]	\$ 439
6' Flex Cable	A871972	A871972A [S]	\$ 331
14' Sealtight Cable — 7/8" dia.	A879168	A879168A [S]	\$ 1059

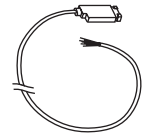

Ceiling Electrical Infeed Cable

Ceiling Electrical Infeed Cables			
12' Flex Cable	A871912	A871912A [S]	\$ 449
18' Flex Cable	A871918	A871918A [S]	\$ 565

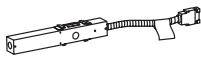

Hardwire Power Infeed

Hardwire Power Infeed (New York Code)			
For 30"–72" W panels	A871400	A871400A [S]	\$ 431
Note: Customer to furnish all cabling and wiring from power entry to power source. (Approved for use by city of New York.)			
Hardwire Junction Box (6-pack)	A871500	N/A [S]	\$ 931



Hardwire Junction Box

Note: Junction box can be positioned at any duplex receptacle location for single-sided application. Customer must furnish conduit, wiring and designer-type receptacle. (Approved for use by city of Chicago.)

Receptacle Color Recommended to Coordinate with Paint Color

Paint Color	Recommended Receptacle Color
Bungalow — P7C.....	Muslin — EU
Champagne Metallic — PR5.....	Muslin — EU
Cinder — P7Q.....	Brownstone — EY
Fossil — P28.....	Flint — E9
Gunmetal Metallic — PR3.....	Brownstone — EY
Parchment — P93.....	Muslin — EU
Pebble — P8R.....	Loft — EV
Pewter — P8D.....	Flint — E9
Platinum Metallic — PR2.....	Loft — EV
Salt — P8C.....	Silver — ES
Titanium — P8T.....	Silver — ES

Note: Four-circuit components and three-circuit components (with an "A" suffix) cannot be connected together.

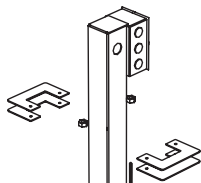

Description	Model	P1 List Price	P2 List Price	P3 List Price
Integrated Power/Communication Pole for Optimize				
For 4 1/2"H-65"H Panels — 78"H	P278PP [S]	\$ 1005	\$ 1023	\$ 1036
For 4 1/2"H-65"H Panels — 156"H	P2156PP [S]	\$ 1334	\$ 1355	\$ 1372



Power/Communication Pole				
10'5" long w/o Receptacles — 2 1/4" square	A870070	\$ 799	N/A	N/A
Note: Limited availability of P1 paint options. P2 and P3 options do NOT apply to this model.				

<p>How to specify — Select the Model Number from above.</p>	<p>1st Option: Electrical Receptacle Color (if applicable): See page 68 for finishes.</p> <p>E </p>	<p>1st Option: Color (if applicable): P Black</p> <p>P </p>	<p>1st Option: Paint (if applicable): P1 P2 P3 See page 68 for finishes.</p> <p>P </p>
--	---	---	--

Examples: A871501.E4 A879072.P A871912A.P P278PP.PR2

[S] Shippable by small-package carrier.

For specification information see pages 83-91.

GSA SIN 33721

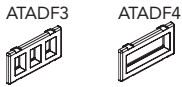

Description	Model	List Price
Data Faceplates		
Three-Port Flex-Mode Faceplate, Black (E4)	ATADF3 S	\$ 42
Four-Port Flex-Mode Faceplate, Black (E4)	ATADF4 S	\$ 42

Notes: ATADF3 can install up to 3 jacks (CAT 3, 5E or 6). ATADF4 can install 4 jacks (CAT 3, 5E or 6).

ATADF models are compatible with ports in Optimize base pathway.

Allsteel's data faceplates are designed for use with the jacks listed below. We do not guarantee compatibility with other manufacturers' product. A faceplate adapter is available for use with alternatively sourced data jacks, see the Standard Specials catalog for details.



Jacks		
RJ45 CAT 5E Jack — Black only Toolless	ATADJ5 S	\$ 74
RJ45 CAT 6 Jack — Black only Requires Tool	ATADJ6 S	\$ 98

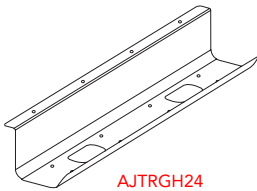

Cable Management Trays		
24"W	AJTRGH24 S	\$ 123
36"W	AJTRGH36 S	\$ 147

- Available in 24" or 36" widths.
- Metal Cable Management Trays available in Black only, specify "P" for finish.
- Example: AJTRGH24.P

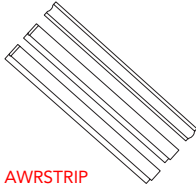

Wire Management Strips/Channels		
	AWRSTRIP S	\$ 270

- Four wire management strips/channels in black only, no specification needed.
- Example: AWRSTRIP

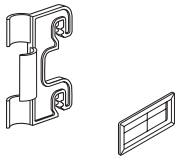

Cord Retainer Clip		
Package of 50 (Black only)	AAPACM2	\$ 56



Wireway Grommet (Black only)		
Pack of 6	TAWG S	\$ 187

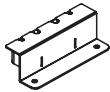

Replacement Receptacle Covers (specify cover color)		
Pack of 25	PRECPCVR S	\$ 136

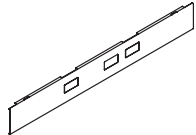

Description	Model	List Price		
		P1	P2	P3
Cord Organizer				
4"W x 7/8"D Metal with 4 cable cutouts	U9WTC S	\$ 196	\$ 205	\$ 212

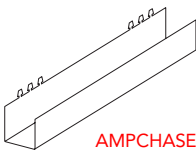

Base Pathway Covers — with additional knockout				
36"W	CBPLATE3-36	\$ 101	\$ 119	\$ 132
42"W	CBPLATE3-42	\$ 103	\$ 121	\$ 134
48"W	CBPLATE3-48	\$ 110	\$ 128	\$ 141
60"W	CBPLATE3-60	\$ 127	\$ 145	\$ 158

Panel Mounted Wire Chase				
17"H	AMPCHASE S	\$ 147	\$ 162	\$ 169

- Panel Chase is 17"H.
- Available in standard metal paint finishes, see page 240 for options and specify desired finishes.
- Example: AMPCHASE.P27

<p>How to specify — Select the Model Number from above.</p>	<p>1st Option: Paint Color (if applicable): P1 P2 P3 See page 68 for finishes.</p>	<p>1st Option: Wireway Grommet, Receptacle Covers, and Data Faceplate Color: E</p>
<p>_____ . P _____</p>		

Examples: A870300 AJTRGH24.P TAWG.E4 ATADF4.E4
PRECPCVR.EU U9WTC.PR2

S Shippable by small-package carrier.

Add Suffix "N" to model number for no grommets, no upcharge.

Laminate with Flat Edge

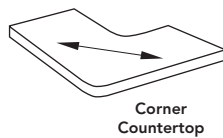
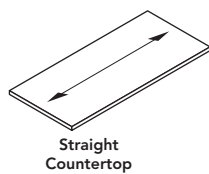
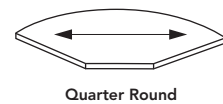
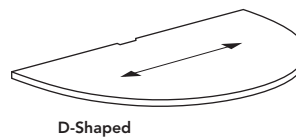
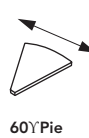
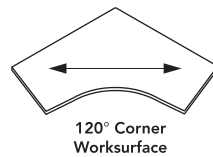
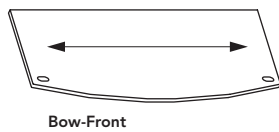
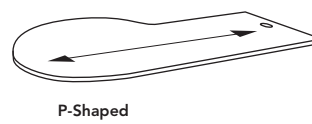
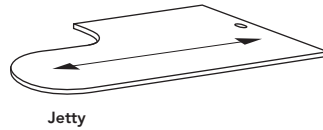
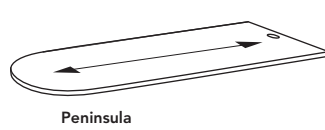
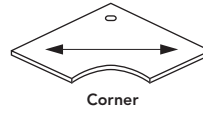
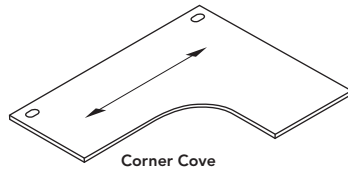
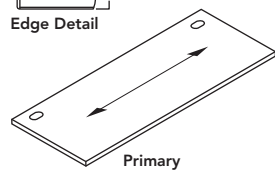

←→ Arrows indicate grain direction for woodgrain laminates.
Grain direction on symmetrical corner worksurfaces runs at a diagonal.

OPTIMIZE

Worksurfaces are 1½" thick with particleboard core and with top surfaces finished in laminate. Bottom surfaces are covered with a backer sheet. Worksurfaces can be panel hung or used in freestanding applications. Modesty panels and appropriate supports are required to configure freestanding Cadence® desks.

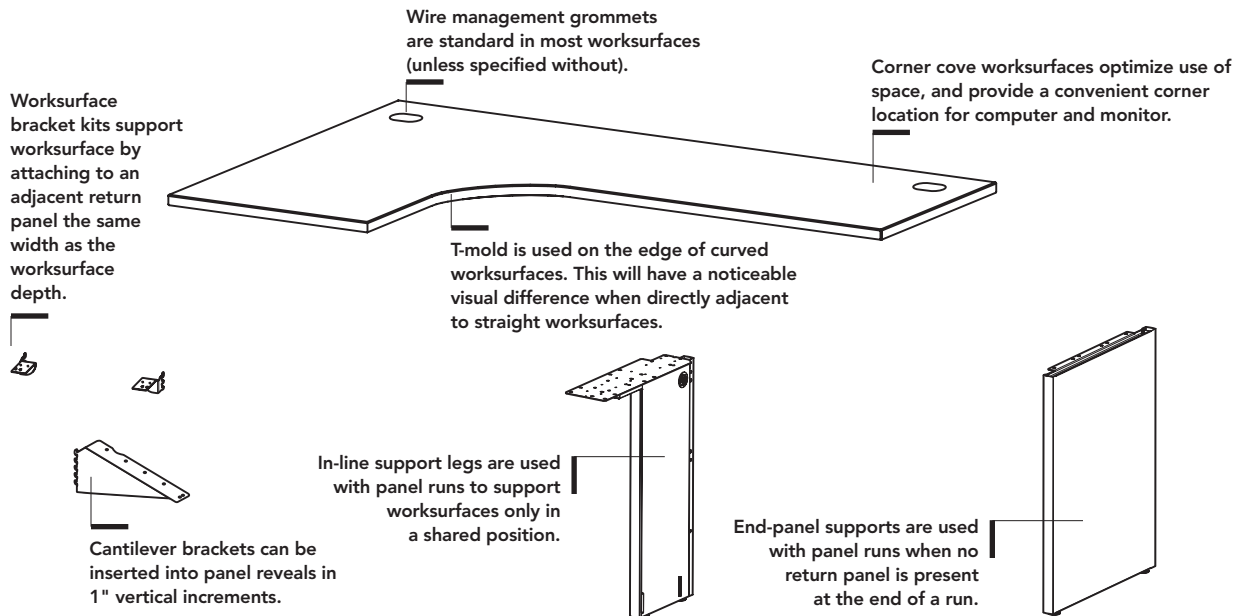

Worksurfaces

- **Laminate tops** offer flat edge trim in twenty standard colors (customer specified) to match solid or woodgrain laminates and to complement patterned laminates.
- **Optional wider width primary worksurfaces** are available for use with Optimize panel runs having a "T" or "S" connection — upcharge applies.

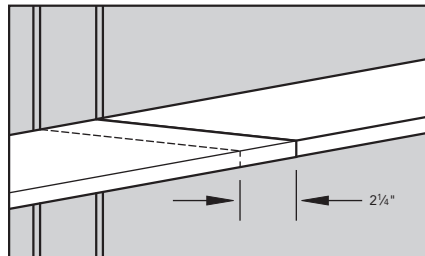
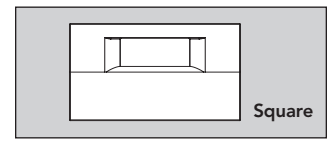
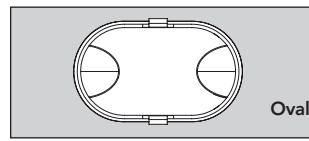
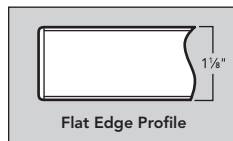

- **Wire management grommets** are standard in most worksurfaces (unless specified with no grommets) and specified in plastic or metal. Metal grommets are available in oval or square.
- Rectangular worksurfaces over 42"W have two grommets. Corner cove worksurfaces will have two grommets. Peninsula and corner worksurfaces have one. D-Shaped worksurfaces and countertops do not have grommets.
- Grommets on standard systems worksurfaces are located 6 ⅙" from the side edges and 3 ⅙" from the back edge.
- Add Suffix "N" to a model number for no grommets — no upcharge.

Supports

Worksurfaces can be configured at 29½" H with end-panel supports and in-line support panels, or at various heights on 1" increments using specific product configurations.

Worksurface support options include:

- Support column*
- Flat brackets
- External support channel
- Worksurface bracket kits
- Height adjustable mechanisms
- Cantilever brackets
- In-line support legs*
- End-panel supports*
- Support storage units*
- Pedestal-to-panel attachment kit*
- Desk-to-panel attachment kit*
- Corner desk leg
- Bridge and return kits
- Modesty panels
- Gussets

*Units provide floor support.

Support Guidelines — See Drawings on page 97

- Panel mounted worksurface runs 96" and greater need floor support for improved stability when overheads are not used.
- When using overheads in panel mounted worksurface run applications 72" and greater, floor support* is required. (See list at left.)
- When using overheads at the end of a panel run, floor supports* are required.
- Worksurface bracket kit should be used to tie panels to worksurface for added stability.
- A return panel at the end of a panel run can be substituted with one of these floor supports: storage, open or closed end support panel, O-leg.

continued on next page

continued from previous page

- Cantilever brackets cannot be used at the end of a worksurface panel run in place of a return panel or floor support.
- Worksurface runs 60" W or greater require an external worksurface support channel when a center support cantilever cannot be used. It is recommended for spans greater than 48" W. See pages 101 and 112.

- Support channel may interfere with mounting of some CPU holders and keyboard supports.
- Cantilevers are recommended in place of an external worksurface support channel where feasible.
- Cadence Desking configurations utilize modesty panels and gussets in place of external support channels for worksurfaces up to 72" W. See pages 102-110.

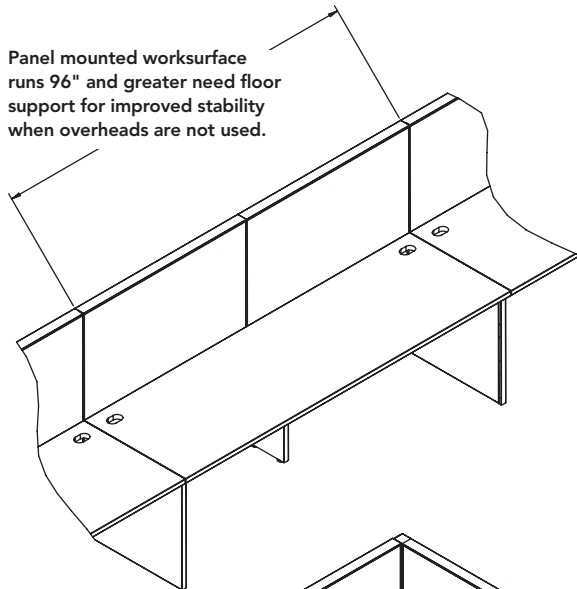

Panel mounted worksurface runs 96" and greater need floor support for improved stability when overheads are not used.

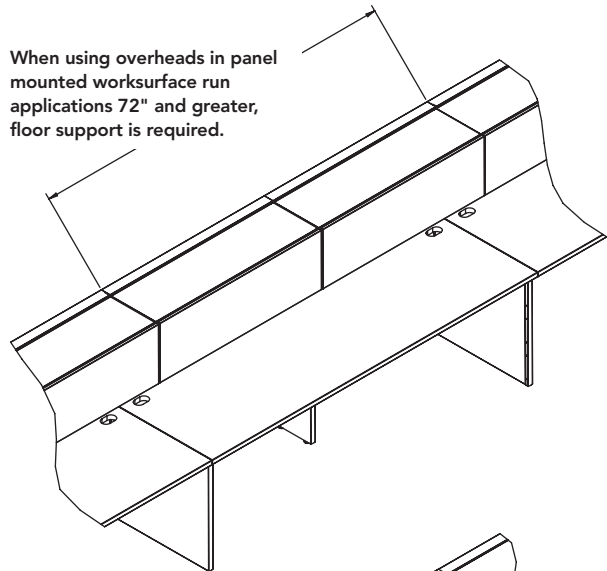

When using overheads in panel mounted worksurface run applications 72" and greater, floor support is required.

Worksurface bracket kit should be used to tie panels to worksurface for added stability

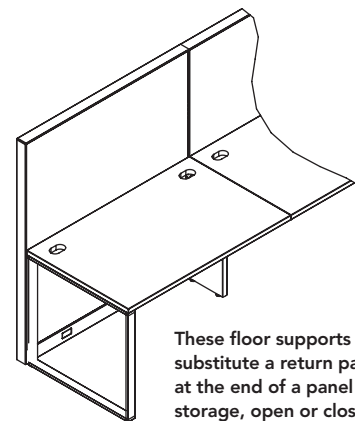
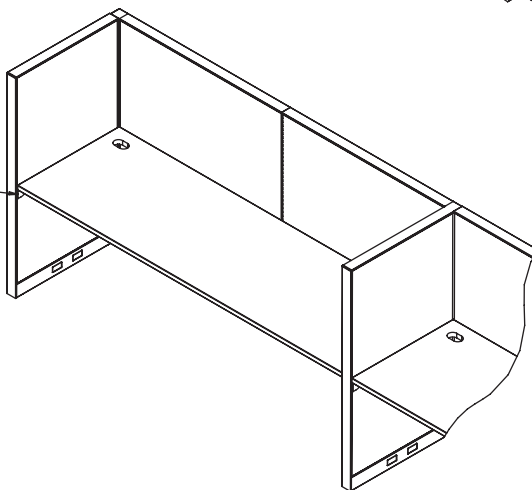
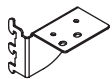

These floor supports can substitute a return panel at the end of a panel run: storage, open or closed end support panel, O-legs.

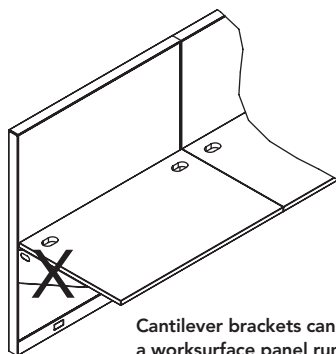

Cantilever brackets cannot be used at the end of a worksurface panel run in place of a return or floor support.

Cantilevers are recommended in place of an external worksurface support channel where feasible.

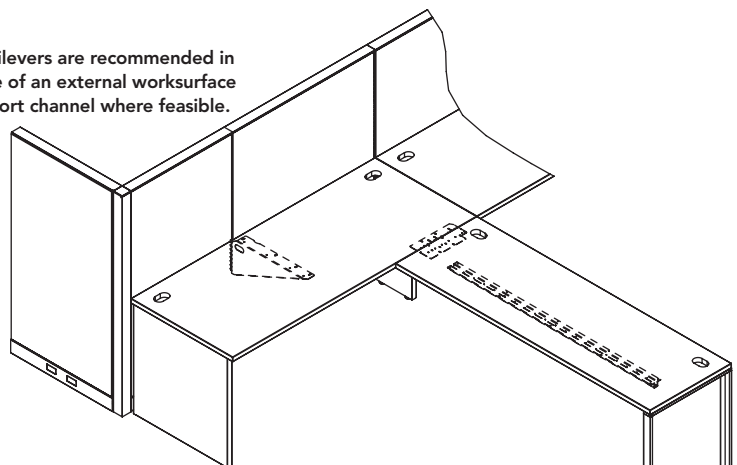

Worksurface runs 60" W or greater require an external worksurface support channel when a center support cantilever cannot be used. It is recommended for spans greater than 48" W. See pages 101 and 112.

OPTIMIZE

Worksurfaces with Flat Edge



Primary Worksurfaces (page 111)

- Primary worksurfaces are available in 20", 24", and 30" depths up to 96"W. Worksurface spans greater than 72" require floor support.
- Nominal worksurface width is equal to nominal panel width.
- Wire management grommets standard, one for widths up to 42", two on widths 48"W and greater. Add "N" suffix for no grommets.
- Worksurfaces greater than 60"W require a cantilever bracket for center support in panel mounted applications. Specify 18" cantilever on 20"D, and 24" cantilever on 24"D and 30"D worksurfaces.
- Width must correspond with panel width(s). For worksurface to span a "T" or extended straight connection add upcharge and suffix "TM" to model number.
- Primary worksurfaces can be used with a modesty panel and appropriate supports to configure freestanding desk(s). Refer to Working With Cadence®, pages 102-110.
- The 9120 Program can be used to order HPL particle board rectangular worksurfaces in any non-standard width and depth in 1/8" increments up to a maximum of 120"W x 36"D. See pages 118-119.



Bow-Front Worksurfaces (page 112)

- Two wire management grommets standard.
- Can be used with a modesty panel and appropriate supports to configure freestanding desk. Refer to Cadence pages 102-110.



Corner Worksurfaces (page 113)

- One wire management grommet.
- Corner worksurfaces with woodgrain laminate have grain direction diagonal to adjacent worksurfaces.
- Does NOT include rear support bracket. If rear support bracket is needed, order T6BK. Worksurface bracket kit (order separately) required at junction where a panel is wall-mounted to a permanent wall and wall track stanchion is not positioned in the right-hand corner.
- T-mold is used on the edge of curved worksurfaces. This will have a noticeable visual difference when directly adjacent to straight worksurfaces.

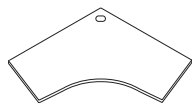

120° Corner Worksurfaces (page 113)

- Standard with one wire management grommet in corner location.
- Does NOT include rear support bracket. If rear support bracket is needed, order T6BK. Worksurface bracket kit (order separately) required at junction where a panel is wall-mounted to a permanent wall and wall track stanchion is not positioned in the right hand corner.
- T-mold is used on the edge of curved worksurfaces. This will have a noticeable visual difference when directly adjacent to straight worksurfaces.

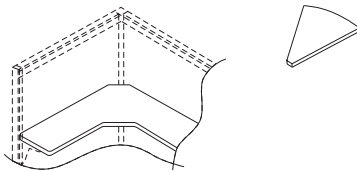

60° Pie Worksurface (page 113)

- Order support column and two flat brackets separately.

Corner Shelf (page 113)

- Diagonal leading edge = 10½"; diagonal depth = 22½".
- Includes panel attachment brackets.

Corner Cove Worksurfaces (page 114)

- Two wire management grommets standard.
- Does NOT include rear support bracket. If rear support bracket is needed, order T6BK. Worksurface bracket kit (order separately) required at junction where a panel is wall-mounted to a permanent wall and wall track stanchion is not positioned in the right-hand corner. All other support hardware is ordered separately.
- Can be used with a modesty panel and appropriate supports to configure freestanding desk(s). Refer to Cadence pages 102-110.
- Worksurfaces greater than 60"W require a cantilever bracket for center support in panel mounted applications. Specify 24" cantilever on 24"D and 30"D worksurfaces.
- T-mold is used on the edge of curved worksurfaces. This will have a noticeable visual difference when directly adjacent to straight worksurfaces.

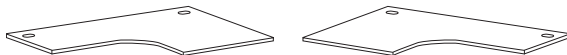

Worksurfaces with Flat Edge

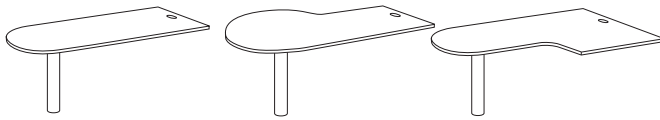

Peninsula, P-Shaped, and Jetty Worksurfaces (page 115)

- Wire management grommets standard.
- Support column ordered separately, column includes panel support brackets T6BK.
- Can be used with a modesty panel and appropriate supports to configure freestanding desk(s). Refer to Cadence® pages 102-110.

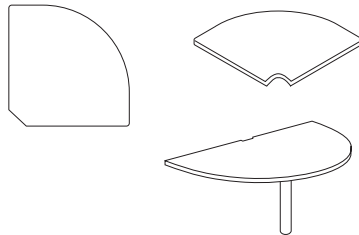

Quarter-Round Worksurfaces (page 116)

- Use to connect two 90° panel-attached worksurfaces.
- Order support column and two flat brackets separately.

D-Shaped Worksurfaces (page 116)

- Order support column and two 24" D in-line support legs separately.
- Not recommended for use with T6CB24L or T6CB24R for shared applications.
- Includes attachment bracket.

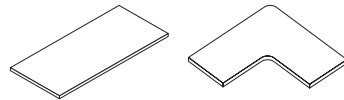

Countertops (page 117)

- Mounting brackets and attaching hardware ordered separately.
- Countertops are flush with panel top cap.
- T-mold is used on the edge of curved worksurfaces. This will have a noticeable visual difference when directly adjacent to straight worksurfaces.



Countertop Brackets (page 117)

- Countertop brackets must be ordered separately. Models P51500 and P51500-42 each contain one right-hand and one left-hand bracket.
- Specify paint color.
- Model P51500 brackets are for 35"H or 50"H panels. Model P51500-42 brackets are for 42½"H panels.
- Order two model P51500 or P51500-42 for straight countertops. Order three model P51500 or P51500-42 for corner countertops.

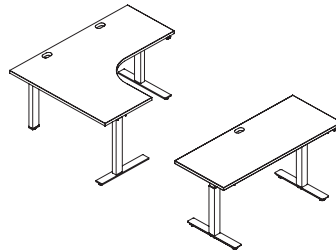

Height-Adjustable Worksurfaces

- For freestanding applications, see height-adjustable tables in the Seating, Collaboration, and Tables Price List.

Non-Standard Worksurface Sizes (pages 118 and 119)

- The 9120 Program can be used to order particle board rectangular worksurfaces in any non-standard width and depth in ½" increments up to a maximum of 120" W x 36" D.
- Other modification requests should be made through Allsteel Tailored Products Group.

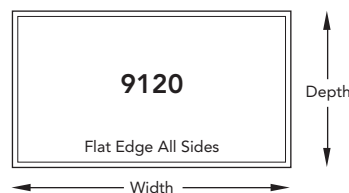

Worksurface Supports

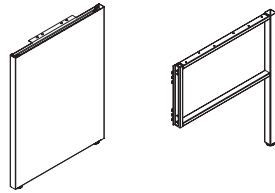

End-Panel, Closed End, and Open End Supports

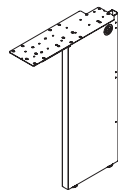

Support Legs

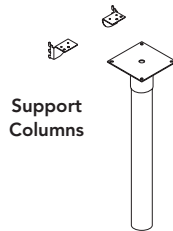

Support Columns

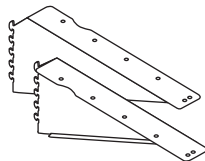

Handed Cantilever Brackets

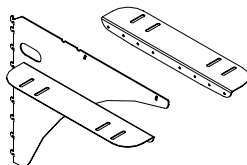

Non-Handed Cantilever Brackets

End Supports and Bracket Kits (page 120)

- End-panels are 1½" thick. For use in place of panels at the end of worksurface runs.
- Levelers provide 1½" vertical adjustment.
- Must be connected into panel slots for panel hung applications.
- Straight worksurfaces adjacent to 120° connections must be supported by full end-panels.
- 11"D end-panel models for use with D-shaped worksurfaces or curvilinear shaped worksurfaces in freestanding applications.
- Panel mounted end-panel supports are ordered for right- or left-handed application.
- Open end panel supports are non-handed and are only for panel mounted applications.
- End-panel models can be converted to freestanding with removal of panel mount bracket. End-panel bracket kit converts freestanding end-panel support model to panel mounted.

Support Legs and Bracket Kit (page 120)

- Support legs are 1½" thick. Leg portion is 12¾"D. Supports the junction of two worksurfaces.
- Non-handed for use at either end of worksurface.
- Provided with flat bracket.
- Worksurface in-line support legs are used to support worksurfaces only in a shared position. Worksurfaces require to the floor support every 72".
- Levelers provide 1½" vertical adjustment.
- Must be connected into panel slots for panel hung applications.
- Panel mounted models can be converted to freestanding with removal of panel mount bracket.
- Support leg bracket kit (non-handed) converts freestanding model to panel mounted.

Support Columns (page 120)

- Used to support one end of curvilinear worksurfaces.
- D-shaped, P-shaped, peninsula, jetty, boomerang, and reef worksurfaces require support columns (ordered separately).
- Includes column, worksurface bracket kit T6BK, attaching hardware, and adjustable glides.

Cantilever Brackets — handed (page 120)

- Cantilever brackets are left or right handed. No assembly required.
- They can be inserted into panel reveals in 1" vertical increments.
- One size is used for both 24" and 30"D worksurfaces.
- 18"D cantilever are for use with 20"D worksurfaces and to support 24"D worksurfaces 66"-72"W that require a cantilever bracket for center support in panel mounted applications.
- 12"D cantilevers are only for use with 12"D secondary worksurfaces.
- Both left and right brackets are required in shared applications.
- Includes tie bracket and attachment hardware.
- Use with runs 72" or less — avoid installation on only one side of a straight connection except to support corner worksurfaces. Floor support is required for runs greater than 72". See page 97.
- Cantilevers can and should still be used in the middle of a worksurface run 72"W or less for proper support and to help prevent worksurface bowing. See page 97.
- DO NOT position at the end of a panel run.
- DO NOT use to support worksurfaces from which a hanging pedestal is suspended or peninsula worksurface is attached.
- DO NOT use cantilever brackets to support worksurfaces supported with permanent-wall hanger kit.

Cantilever Bracket — non-handed (page 120)

- Assembly required. Includes attachment hardware.
- Includes two angle brackets for shared applications. Use two cantilever brackets when adjacent worksurfaces are positioned at different heights.
- One size is used for both 24" and 30"D worksurfaces.

Worksurface Supports

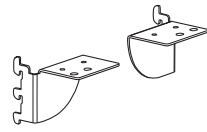

Worksurface Brackets

Worksurface Bracket Kit — T6BK (page 120)

- Worksurface bracket kit allows one end of a worksurface to be supported by a return panel. Return panel width must be the same as the depth of the worksurface.
- Kit includes one pair of brackets and attachment hardware.
- Freestanding pedestals can also be used to support one end of a panel-attached worksurface in conjunction with worksurface bracket.

Worksurface Storage Bracket Kit — T6SB (page 120)

- Worksurface storage bracket kit (T6SB) is used for aesthetics where under-desk storage is immediately adjacent to the return panel. In all other applications use worksurface bracket kit (T6BK) to utilize worksurface threaded metal inserts.
- Black only.
- Kit includes one pair of brackets and attachment hardware.
- Brackets do not align with worksurface threaded metal inserts, and therefore require wood screws (included).

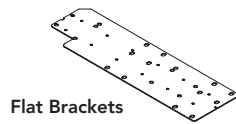

Flat Brackets

Flat Brackets (page 120)

- Includes bracket and attaching hardware.
- Can be used to connect one worksurface perpendicular to another worksurface.

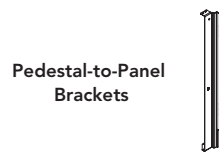

Pedestal-to-Panel Brackets

Pedestal-to-Panel Attachment Bracket (page 120)

- Can be used in place of full end panel or return panel.
- Provides structural support to panel run by securing panel directly to pedestal.
- Works with Essentials™ and Involve® pedestals.



External Worksurface Support Channel

External Worksurface Support Channel (page 112)

- Is required on a systems worksurface for additional support for spans 60" W or greater. Width of worksurface span can be reduced by using support storage.
- Extends 1½" below the worksurface. Installs 7" from user's edge.
- When using 28" H mobile pedestals the length of support channel needs to be reduced to accommodate width of the pedestal.
- Support channel may interfere with mounting of some CPU holders and keyboard supports. May require spacer kit AKMH.

Freestanding Desks

- Freestanding desks can be created by combining primary and corner worksurfaces with modesty panels and appropriate desk supports. See Cadence® pages 102-110.

Cadence offers unlimited versatility. Its modular flexibility creates office solutions of all shapes, sizes, and styles.

Configurations

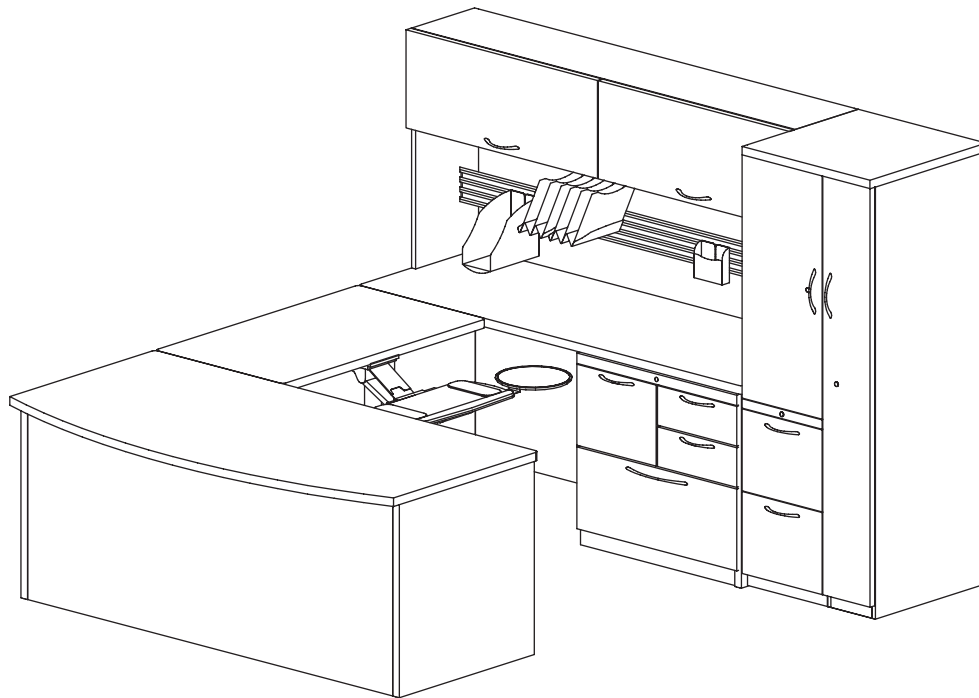

Full Modesty

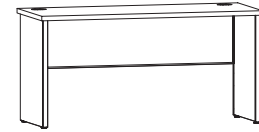

Half Modesty



Gussets

All the right choices

Choose Cadence freestanding desking with confidence. It personalizes any work environment, accommodates a range of needs, and offers all the right features — curvilinear worksurface shapes, multiple worksurface edges, and a complete paint finish and laminate offering. Cadence is made to last with heavy-gauge steel construction. Metal-to-metal worksurface connection points make installation and reconfiguration reliable and easy. And Cadence is backed by a lifetime warranty.

Universally flexible

Cadence sets up easily and reconfigures time after time. It even shares components with Optimize, Terrace®, and Concensys®, which simplifies inventory management. Cadence is created with worksurfaces, supports, modesty panels, end panels, and brackets. Cadence is compatible with the entire line of Allsteel storage solutions and Extensions™ — work tools to provide personalized organization for every workstyle.

Systems integration — Cadence works in combination with Optimize, Terrace, or Concensys panels, extending the functionality of each product line.

Highly adaptable — Make the most of building architecture by using an existing wall to create a semi-private workspace.

Space utilization — Multiple worksurface shapes offer unlimited design potential for using space creatively and efficiently.

Team interaction — Cadence design flexibility allows you to create personal workspace and a team collaboration area in the same office.

The Cadence choice

It works in the open plan, the private office, or in combination with Optimize, Terrace, or Concensys panels, allowing complete office coordination. The flexible, universal design of Cadence supports virtually any workstyle and any interior aesthetic. Backed by Allsteel's Lifetime Warranty and manufactured to strict environmental standards, Cadence provides one high-value package.

Configurations

End Panels **E** and Support Legs **L**

Each are available in two options: freestanding or panel-mount. If the freestanding version is purchased and later needs to be converted to panel-mount, the proper handed panel-mount bracket may be purchased separately.

The 11"D end panel is used to freestand peninsulas, curvilinear shapes, and D-tops in panel applications.

Corner Desk Legs **C**

Corner desk legs have a 90-degree bend and welded construction. The strong construction allows gussets or half-height modesty panels to be used with corner legs.

Bridge Kits **B**

Bridge kits include: two flat brackets, two modesty panel-to-end panel attachment brackets, and two tie straps. This kit is used when attaching a bridge unit between two rectangular worksurfaces.

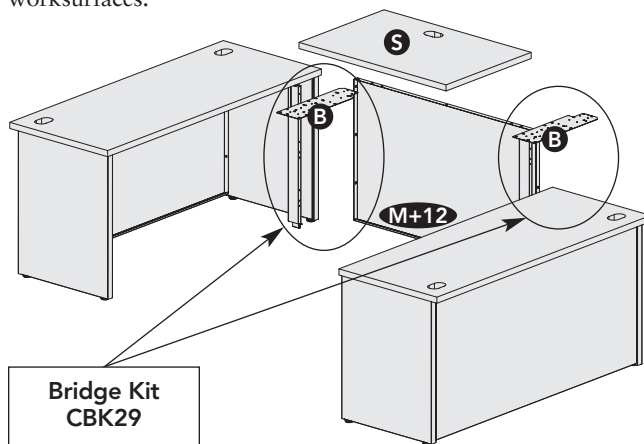

There are some bridge instances where only half of a bridge kit is needed (e.g. using a bridge between a rectangular worksurface and a corner or peninsula). A return kit may be ordered for these instances.

Surface **S**

Support Column **SC**

Support columns are used to support one end of curvilinear worksurfaces. Includes column, worksurface bracket kit T6BK, attaching hardware, and adjustable glides.

Return Kits **R**

Return kits include: one flat bracket, one modesty panel-to-end panel attachment bracket, and one tie strap. These are used when attaching a return to a primary desk. Return kits can also be used in some bridge applications — one example is shown below when using a peninsula.

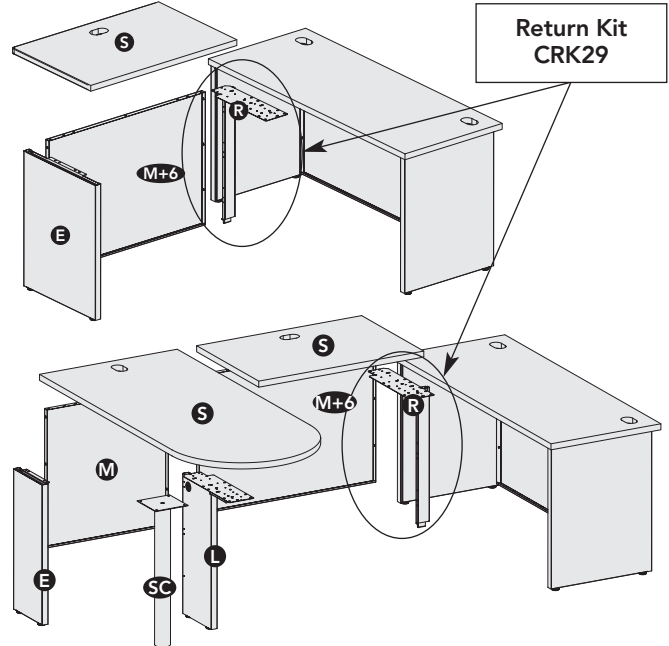

Desk-to-Panel Attachment Kits **D**

Desk-to-panel attachment kits are used to connect a worksurface and modesty panel perpendicular to a panel of corresponding width. Opposing end of worksurface must be attached with an end-panel, support leg, or corner leg mounted directly under this worksurface.

When using a corner or corner cove worksurface with the rear corner attached to a panel, and opposing end of worksurface is attached to a freestanding desk, use corner w/desk attachment kit. Hand of unit is determined from the user's side of the desk (right hand unit attaches to right side of modesty).

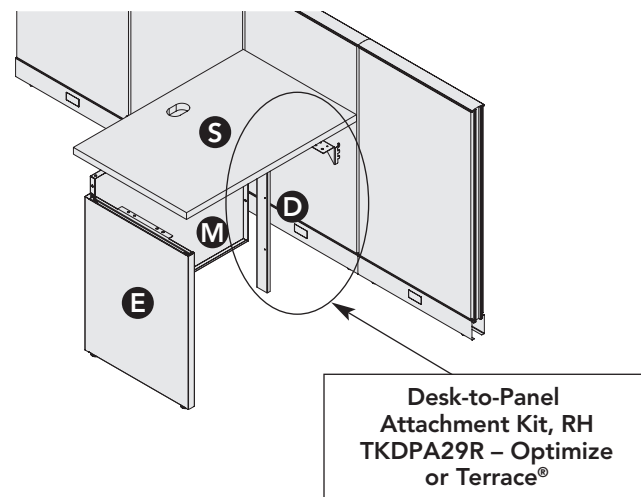

Corner w/Desk Panel Attachment Kit **CW**

Corner w/desk panel attachment kit connects the rear corner of a corner or corner cove worksurface and modesty panel to a panel when the opposing end of the worksurface shares a support leg with an adjacent freestanding desk and the support leg is mounted under the freestanding desk. Hand of unit is determined from the user's side of the desk (left hand unit attaches to left side of modesty).

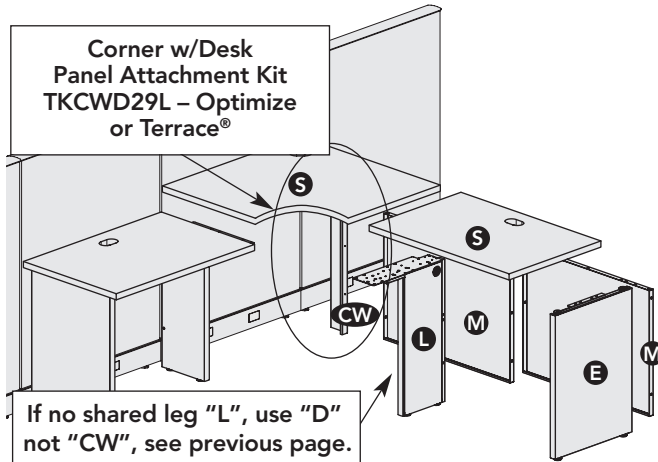

Corner Worksurfaces

Corner worksurfaces to accommodate 90-degree corner desk legs.

In-Line Connections of Desks

Freestanding full end panels must be used to support adjacent rectangular desks, corner desks, and corner desks with returns. Freestanding support legs should NOT be used at the in-line junction. 24" D full end panels may be used at the in-line junction on 30" D rectangular desks if two worksurface tie straps are used to secure the desks together. Contact Allsteel Customer Support for ordering information.

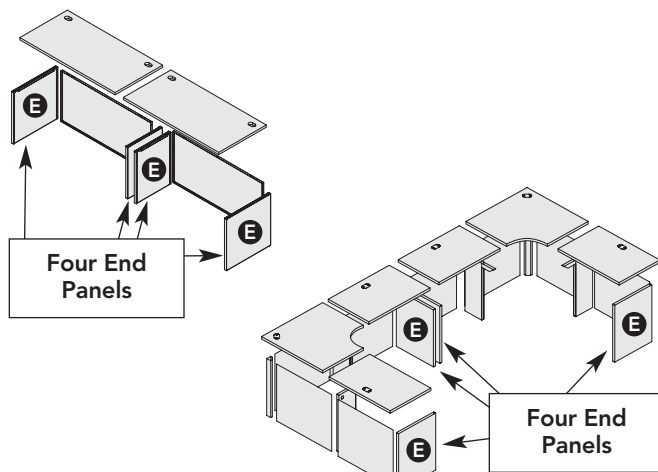

Pedestals and Storage

Pedestals must be ordered one size smaller than the depth of the worksurface. For example, 18" D or 20" D peds should be used with 24" D worksurfaces. 18", 20" D, or 23" D pedestals can be used with 30" D worksurfaces. Using 18" D laterals or personal files provide additional pull style and storage options under 24" D worksurfaces.

Modesty Panels **M**

The following are some general guidelines for Cadence modesty panels:

- **Desk:** Modesty panel width is the same width as the worksurface
- **Return:** Modesty panel width is 6" greater than the width of the worksurface
- **Bridge connecting two rectangular worksurfaces:** Modesty panel width is 12" greater than the width of the bridge worksurface
- **Bridge connecting a rectangular worksurface and corner or peninsula:** Modesty panel width is 6" greater than the width of the worksurface
- **Corner connecting to an adjacent worksurface:** Modesty panel width is the same width as the worksurface.

Stand-Alone Corner Modesty Panels **SM**

Stand-alone corner modesty panels are used only when one or both sides of a corner or corner cove worksurface are freestanding and NOT attached to another worksurface. Specify the width the same as the width of the worksurface.

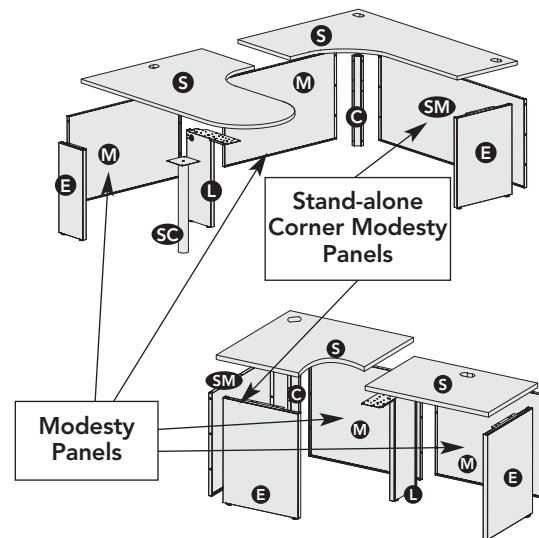

Gussets **G**

Gussets can be used in place of a modesty panel with desks 36" W to 60" W. Gussets can also be used with corner desk legs.

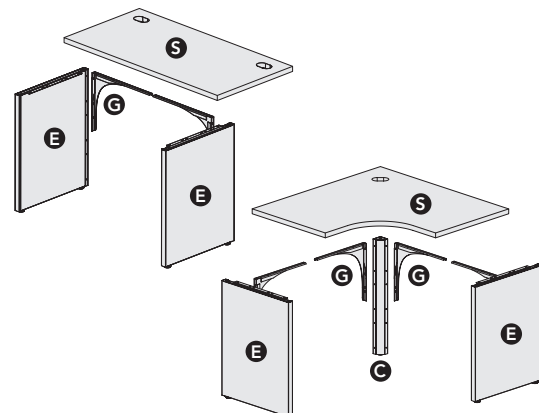

Configurations

Freestanding Desk

Qty.	Model	Description
1	T52436S	Flat Edge Worksurface 24"D x 36"W
2	CEP2429F	End-Panel Support 24"D x 29½"H
1	CS369	Modesty Panel 36"W x 29½"H

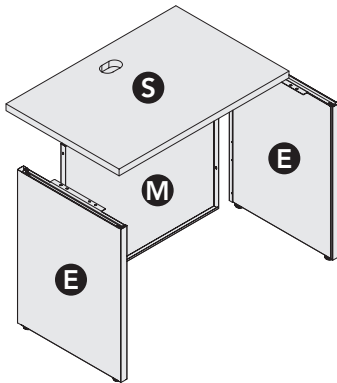

Panel-Attached Desk

Qty.	Model	Description
1	T52436S	Flat Edge Worksurface 24"D x 36"W
1	CEP2429F	End-Panel Support 24"D x 29½"H
1	CS369	Modesty Panel 36"W x 29½"H
1	DPA29R	Desk-to-Panel Attachment Kit 29½"H - RH C - Concensys® TK - Optimize or Terrace®

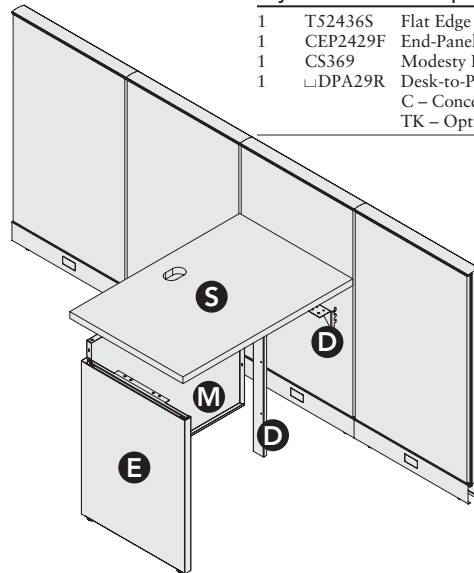

CONFIGURATION OPTIONS	Work-surface (S)	End-Panel Support (E)	Desk Support Leg (L)	Modesty Panel			Desk-to-Panel Attachment Kit (D)	Corner Desk Leg (C)
				Same width as Work-surface (M)	6" wider than Work-surface (M+6)	12" wider than Work-surface (M+12)		
Freestanding Desk	1	2		1				
Panel-Attached Desk	1	1		1			1 RH	

Return Desk (Attached to a primary or return desk.)

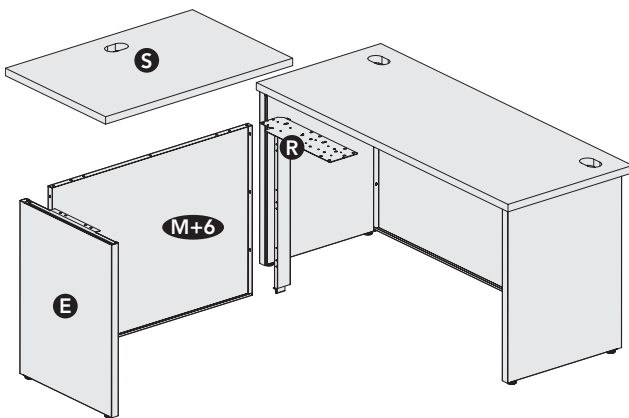

Qty.	Model	Description
1	T52436S	Flat Edge Worksurface 24"D x 36"W
1	CS429	Modesty Panel 42"W x 29½"H
1	CEP2429F	End-Panel Support 24"D x 29½"H
1	CRK29	Return Kit

Return Desk (Attached to a panel-hung worksurface.)

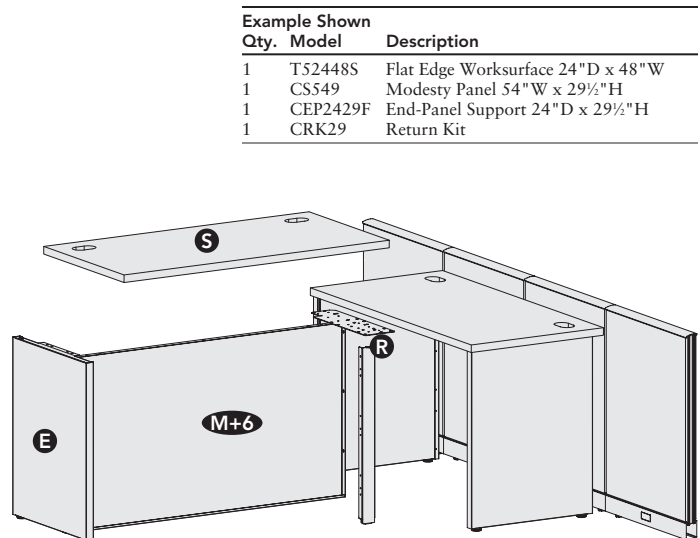

Qty.	Model	Description
1	T52448S	Flat Edge Worksurface 24"D x 48"W
1	CS549	Modesty Panel 54"W x 29½"H
1	CEP2429F	End-Panel Support 24"D x 29½"H
1	CRK29	Return Kit

Note: The widest modesty panel is 72"W which limits return worksurfaces to a maximum of 66"W.

CONFIGURATION OPTIONS	Work-surface (S)	End-Panel Support (E)	Desk Support Leg (L)	Modesty Panel			Desk-to-Panel Attachment Kit (D)	Corner Desk Leg (C)	Return Kit (R)
				Same width as Work-surface (M)	6" wider than Work-surface (M+6)	12" wider than Work-surface (M+12)			
Return Desk	1	1			1				1

Configurations

Bridge Desk (Attached between two primary desks.)

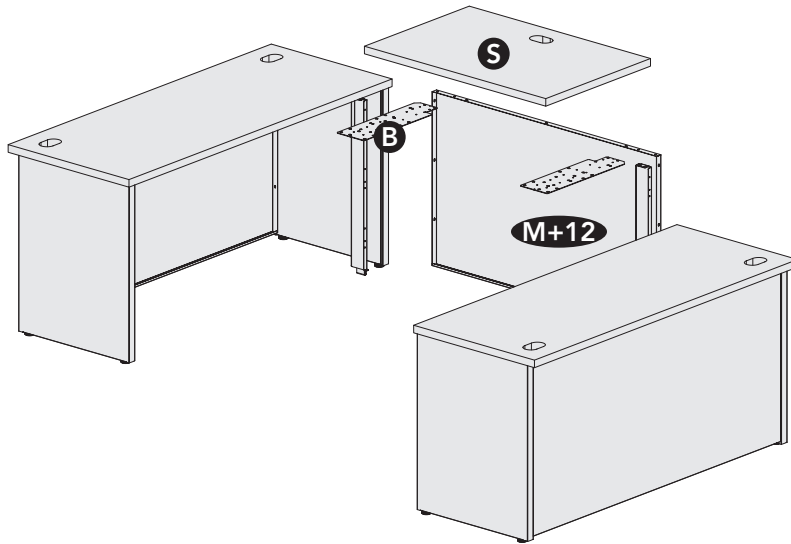

Example Shown

Qty.	Model	Description
1	T52442S	Flat Edge Worksurface 24"D x 42"W
1	CS549	Modesty Panel 54"W x 29½"H
1	CBK29	Bridge Kit

CONFIGURATION	Work-surface (S)	End-Panel Support (E)	Desk Support Leg (L)	Modesty Panel			Desk-to-Panel Attachment Kit (D)	Corner Desk Leg (C)	Bridge Kit (B)
				Same width as Work-surface (M)	6" wider than Work-surface (M+6)	12" wider than Work-surface (M+12)			
Bridge Desk	1					1			1

Bridge Desk and Peninsula (Attached to a primary desk).

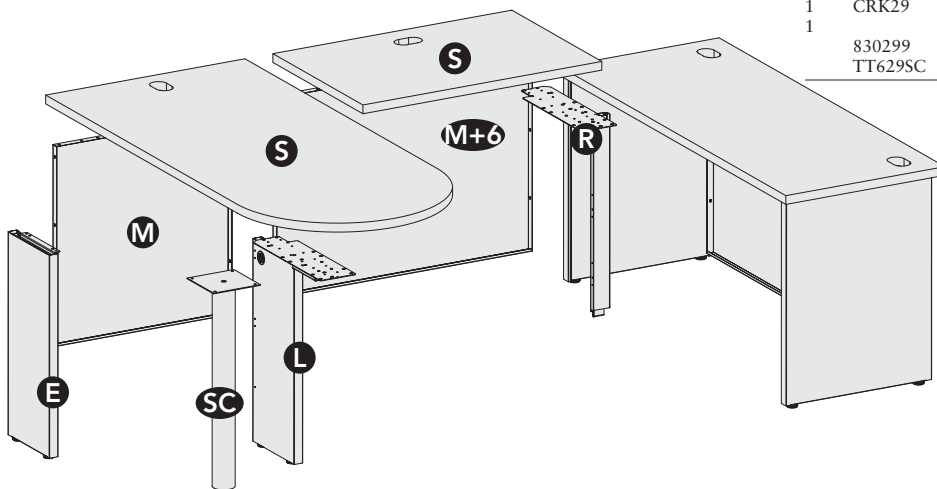

Example Shown

Qty.	Model	Description
1	T52442S	Flat Edge Worksurface 24"D x 42"W
1	T53060B	Flat Edge Peninsula Worksurface 30"W x 60"L
1	CS489	Modesty Panel 48"W x 29½"H
1	CS309	Modesty Panel 30"W x 29½"H
1	CEP1129F	End-Panel Support 11"D x 29½"H
1	CSL2429F	Support Leg 24"D x 29½"H
1	CRK29	Return Kit
1	830299	Support Column for Peninsula Worksurface 29½"H (Concensys®)
1	TT629SC	(Optimize or Terrace®)

CONFIGURATION OPTION	Work-surface (S)	End-Panel Support (E)	Desk Support Leg (L)	Modesty Panel			Desk-to-Panel Attachment Kit (D)	Support Column (SC)	Return Kit (R)
				Same width as Work-surface (M)	6" wider than Work-surface (M+6)	12" wider than Work-surface (M+12)			
Bridge Desk and Peninsula	2	1	1	1	1			1	1

OPTIMIZE

Configurations

Corner Desk (Stand-alone)

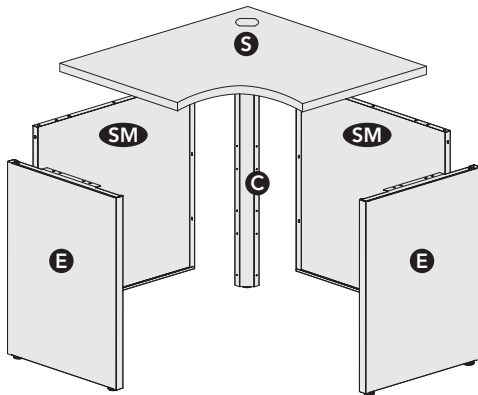

Qty.	Model	Description
1	T53624CR	Flat Edge Worksurface 24"D x 36"W (<i>De-emphasized</i>)
2	CSCMP3629	Stand-Alone Corner Modesty Panel 36"W x 29½"H
2	CEP2429F	End-Panel Support 24"D x 29½"H
1	CDL29	Corner Desk Leg 29½"H

Corner Desk (With an adjacent desk attached at one side.)

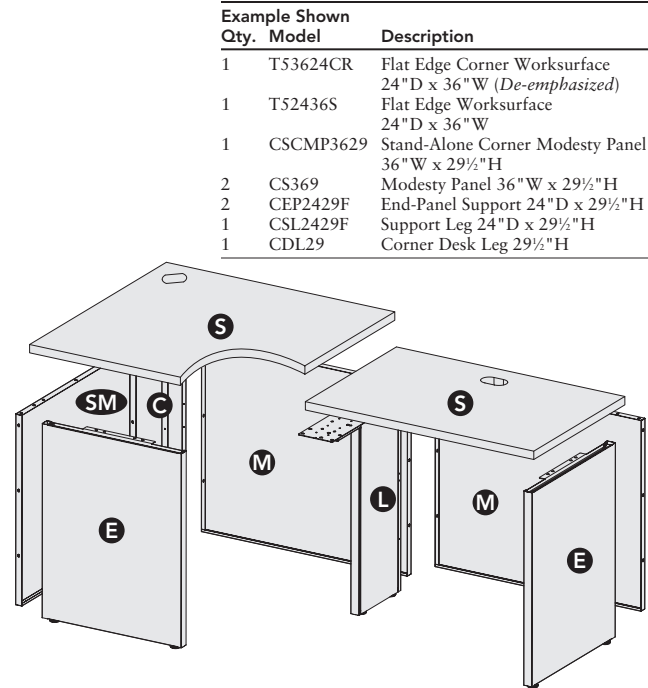

Qty.	Model	Description
1	T53624CR	Flat Edge Corner Worksurface 24"D x 36"W (<i>De-emphasized</i>)
1	T52436S	Flat Edge Worksurface 24"D x 36"W
1	CSCMP3629	Stand-Alone Corner Modesty Panel 36"W x 29½"H
2	CS369	Modesty Panel 36"W x 29½"H
2	CEP2429F	End-Panel Support 24"D x 29½"H
1	CSL2429F	Support Leg 24"D x 29½"H
1	CDL29	Corner Desk Leg 29½"H

CONFIGURATION OPTION	Work-surface (S)	End-Panel Support (E)	Desk Support Leg (L)	Modesty Panel		Stand-Alone Corner Modesty Panel (SM)	Desk-to-Panel Attachment Kit (D)	Corner Desk Leg (C)
				Same width as Work-surface (M)	6" wider than Work-surface (M+6)			
Corner Desk	1	2				2		1
Corner Desk (with adjacent desk)	2	2	1	2		1		1

Bridge Desk (Attached between corner and primary desk.)

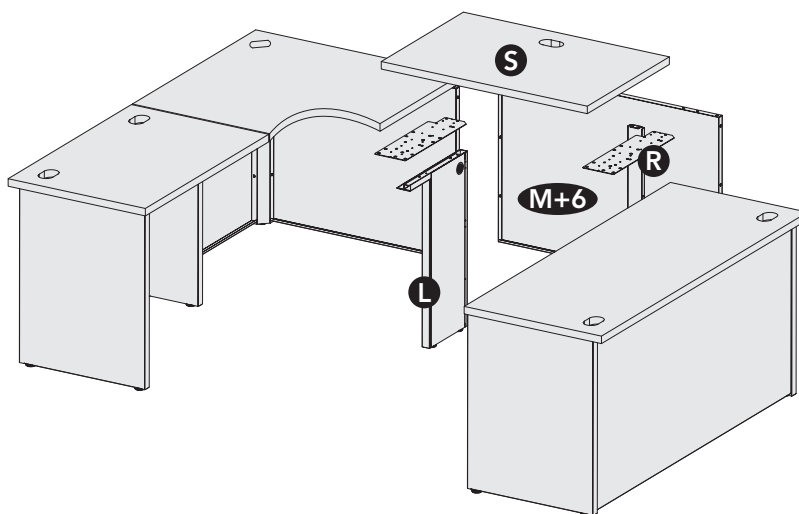

Qty.	Model	Description
1	T52436S	Flat Edge Worksurface 24"D x 36"W
1	CS429	Modesty Panel 42"W x 29½"H
1	CRK29	Return Kit
1	CSL2429F	Support Leg 24"D x 29½"H

CONFIGURATION	Work-surface (S)	End-Panel Support (E)	Desk Support Leg (L)	Modesty Panel			Desk-to-Panel Attachment Kit (D)	Corner Desk Leg (C)	Return Kit (R)
				Same width as Work-surface (M)	6" wider than Work-surface (M+6)	12" wider than Work-surface (M+12)			
Bridge Desk	1		1		1				1

Configurations

Corner Desk (Attached to a panel with an adjacent desk at one side.)

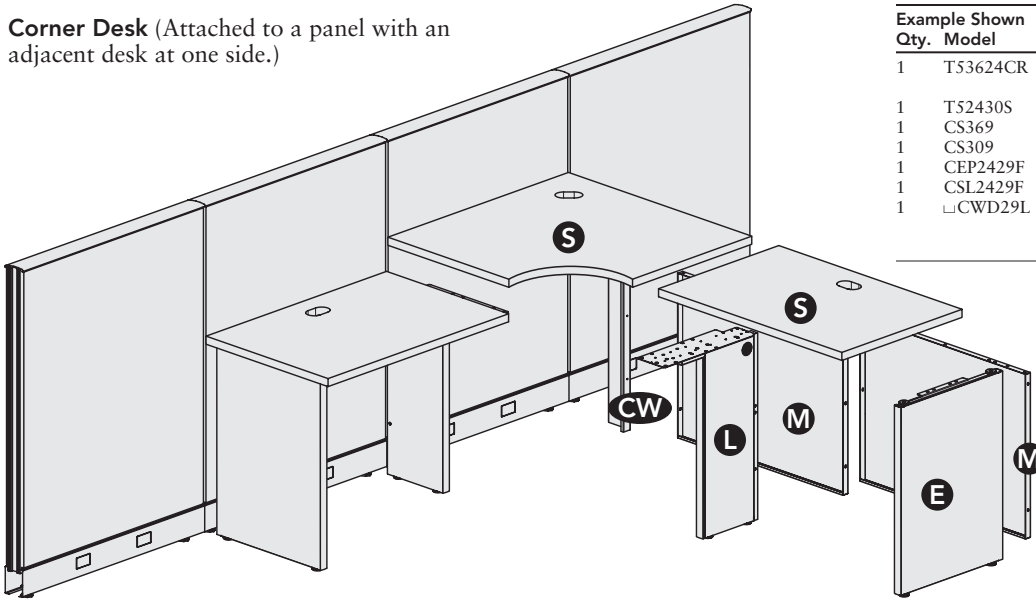

Qty.	Model	Description
1	T53624CR	Flat Edge Corner Worksurface 36"W x 24"D (<i>De-emphasized</i>)
1	T52430S	Flat Edge Worksurface 24"D x 30"W
1	CS369	Modesty Panel 36"W x 29½"H
1	CS309	Modesty Panel 30"W x 29½"H
1	CEP2429F	End-Panel Support 24"D x 29½"H
1	CSL2429F	Support Leg 24"D x 29½"H
1	□CWD29L	Corner w/Desk Attachment Kit 29"H LH

C – Concensys®
TK – Optimize or Terrace®

CONFIGURATION	Work-surface (S)	End-Panel Support (E)	Desk Support Leg (L)	Modesty Panel			Desk-to-Panel Attachment Kit (D)	Corner Desk Leg (C)	Corner w/Desk Panel Attachment Kit (CW)
				Same width as Work-surface (M)	6" wider than Work-surface (M+6)	12" wider than Work-surface (M+12)			
Corner Desk	2	1	1	2					1 LH

"U" with Jetty and Corner Cove

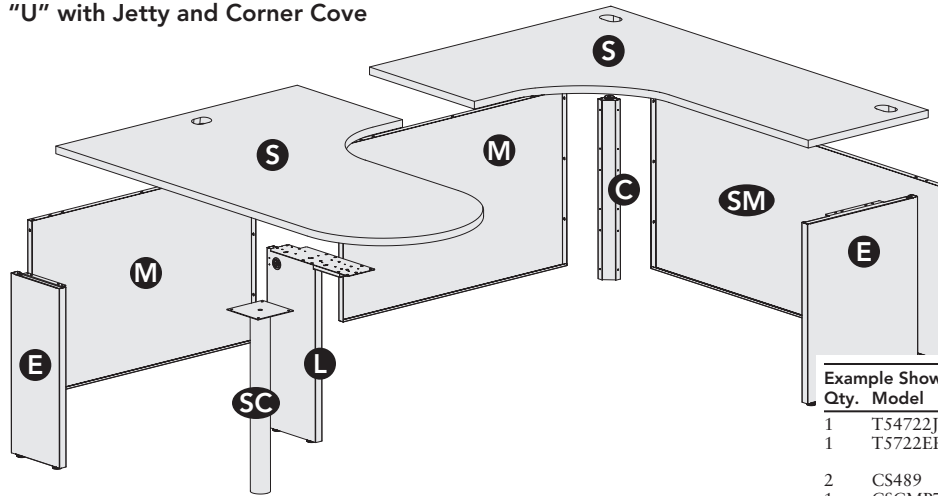

Qty.	Model	Description
1	T54722JR	Flat Edge Jetty RH 48"D x 72"W x 24" x 30"
1	T5722ER	Flat Edge Corner Cove RH 48"D x 72"W x 24"
2	CS489	Modesty Panel 48"W x 29½"H
1	CSCMP7229	Stand-Alone Corner Modesty Panel 72"W x 29½"H
1	CEP1129F	End-Panel Support 11"D x 29½"H
1	CSL2429F	Support Leg 24"D x 29½"H
1	CEP2429F	Full End-Panel Support 24"D x 29½"H
1	CDL29	Corner Desk Leg 29½"H
1		Support Column for Jetty 29½"H (Concensys)
1	830299	(Optimize or Terrace)
1	TT629SC	(Optimize or Terrace)

CONFIGURATION OPTION	Work-surface (S)	End-Panel Support (E)	Desk Support Leg (L)	Modesty Panel		Stand-Alone Corner Modesty Panel (Same width as Work-surface (SM))	Support Column (SC)	Corner Desk Leg (C)
				Same width as Work-surface (M)	6" wider than Work-surface (M+6)			
Cove and Jetty	2	2	1	2		1	1	1

OPTIMIZE

Cadence Supports

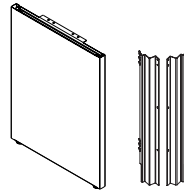

End-Panel Supports

End-Panel Supports (page 121)

- End panels are 1⅝" thick. For use at the end of worksurface runs.
- Levelers provide 1½" vertical adjustment.
- Freestanding models can be converted to Optimize panel-mount with end panel bracket kit.
- Must be connected into panel slots for panel hung applications.
- Straight worksurfaces adjacent to 120° connections must be supported by full end panels.
- 11"D models for use with D-shaped worksurfaces or curvilinear shaped worksurfaces in freestanding applications.

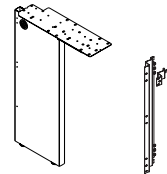

Support Leg

Support Legs (page 121)

- Support legs are non-handed. Supports the junction of two worksurfaces.
- Leg portion is 12¾"D and is 1⅝" thick.
- Flat bracket included.
- Levelers provide 2¾" vertical adjustment.
- Freestanding models can be converted to Optimize panel-mount with support leg bracket (non-handed).
- Must be connected into panel slots for panel hung applications.

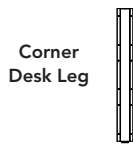

Corner Desk Leg

Corner Desk Leg (page 121)

- Attaches two modesty panels at rear of corner desk.
- Leveler provides 2¾" vertical adjustment.
- See examples on pages 104 and 107.



Bridge Kit

Bridge Kit (page 121)

- Connects bridge worksurface and modesty panel to end panels and worksurfaces that are perpendicular to the bridge worksurface.
- Includes two flat brackets and two modesty panel-to-end-panel brackets.
- See examples on pages 103 and 107.



Return Kit

Return Kit (page 121)

- Connects return worksurface and modesty panel to end panel and perpendicular worksurface — non-handed.
- Includes one flat brackets and one modesty panel-to-end-panel bracket.
- See examples on pages 103 and 105.

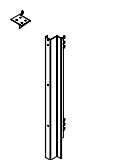

Desk-to-Panel Attachment Kit

Desk-to-Panel Attachment Kits for Optimize (page 121)

- Used to connect a worksurface and modesty panel perpendicularly to a Optimize Panel of corresponding width. Opposing end of worksurface must be attached with an end-panel, support leg, or corner leg mounted directly under this worksurface.
- If using corner or corner cove with the rear corner attached to a panel, and opposing end of worksurface is attached to a freestanding desk — use corner w/desk panel attachment kit.
- “Hand” of unit is determined from the user’s side of the desk (left hand unit attaches to left side of modesty).

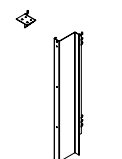

Corner w/Desk Attachment Kit

Corner w/Desk Panel Attachment Kit for Optimize (page 121)

- Used when the rear corner of a corner or corner cove worksurface and modesty panel is attached to a Optimize panel and opposing end of worksurface is attached to a freestanding desk. Opposing end of worksurface shares the support leg that is mounted under the adjacent freestanding desk.
- “Hand” of unit is determined from the user’s side of the desk.

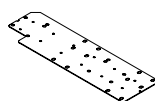

Flat Bracket

Flat Brackets (page 121)

- Bracket and attaching hardware.
- Can be used to connect one worksurface perpendicular to another worksurface.

OPTIMIZE

Cadence Supports

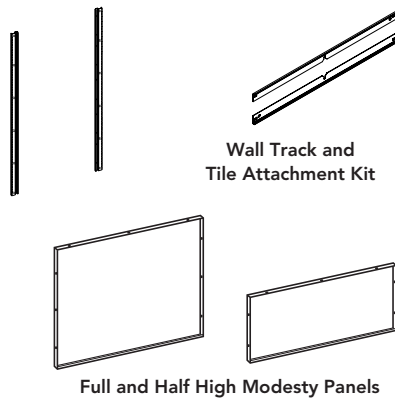

Optimize Wall Track/Tile Attachment Kits (page 121)

- Allows for mounting of system panel components on permanent wall structures.
- Begin with one pair of ends; for multiple kits in line, add middle unit(s) between ends.
- Height of wall track coordinates with panel height. Field cut for lower heights.
- Wall track will add 1" to depth of attached components.
- Use Terrace® wall track tile attachment kit to install tiles onto Optimize wall track. Kit includes two tile bars. Top bar may only be used in the top uppermost position on wall track. Bottom bar can be used in the bottom position at any location on wall track.
- When segmenting tiles on wall track, segment bars must be ordered for placement between all vertically adjacent tiles or at the top position of a single tile that is not in the uppermost position.
- When using Optimize wall track and using Terrace tiles to create a tackboard situation under overheads hung at 65"H, make sure to use a 30"H tile or 2-15"H tiles to cover the entire area between the overheads and the worksurface.

Freestanding Pedestals

- Can also be used to support one end of a panel-attached worksurface in conjunction with worksurface bracket.

Freestanding Desks

- Freestanding desks can be created by combining primary and corner worksurfaces with modesty panels and appropriate desk supports. See pages 102-108.

Pedestal Compatibility with Cadence and Panel-hung Worksurfaces		
Cadence Desking	24" Deep	30" Deep
18"D Ped	Yes	Yes
19"D Ped	Yes*	Yes
23 3/8"D Ped		Yes
29 1/2"D Ped		
Systems Panel-hung	24" Deep	30" Deep
18"D Ped	Yes	Yes
19"D Ped	Yes*	Yes
23 3/8"D Ped	Yes*	Yes
29 1/2"D Ped		Yes*

*Wire management grommet is blocked in these applications.

Note: Pedestal placement may affect access to receptacles in base pathway.

Modesty Panel (page 122)

- Mounts to end-panel supports, desk support legs, bridge kit, return kit, desk-to-panel, and corner w/desk panel attachment kits.
- 29 1/2"H units provide 3/4" of space between bottom of modesty panel and floor.
- Actual width of 29 1/2"H modesty panel is 3/4" less than the nominal dimension listed in the Systems Price List.
- 14"H units provide 1 1/4" of space between bottom of modesty panel and floor.
- Refer to pages 102-108 to select proper width.
- Use 14"H modesty panels for desks positioned against a wall to provide access to electrical receptacles.
- 14"H modesty panels, stand-alone corner modesty panels or gussets can be used with corner or corner cove worksurfaces.

Stand-alone Corner Modesty Panel (page 122)

- 29 1/2"H units provide 3/4" of spacing between bottom of panel and floor.
- 14"H units provide 1 1/4" of space between bottom of modesty panel and floor.
- Actual width of modesty panel is 6 1/16" less than the nominal dimension listed in the Systems Price List.
- Modesty panels are inset 2 7/8"; when adding pedestals, consult chart below.

Pedestal-to-Pedestal Modesty Panels (page 122)

- Widths available to work with 60"W, 66"W, and 72"W worksurfaces to create freestanding double pedestal desk using two medal support pedestals.

Gussets (page 122)

- Provides easy access to wall outlets.
- Cannot be used with suspended pedestals.
- Gussets can be used on corner and corner cove worksurfaces.

Universal Modesty Panel (page 122)

- Mounts under peninsula, P-shape, jetty, and boomerang worksurfaces. Refer to chart below to select proper width.
- Can be used with panel-mounted and freestanding worksurfaces.
- Provides 8 1/2" of privacy and is non-handed.
- Constructed of steel. No upcharge for Select paint.
- Only requires attachment to the worksurface.
- Does not provide electrical, data or structural support.
- Panel is 1 1/2" thick and can be mounted at various distances from edge of worksurface based on user's preference for clearance and conferencing requirements.

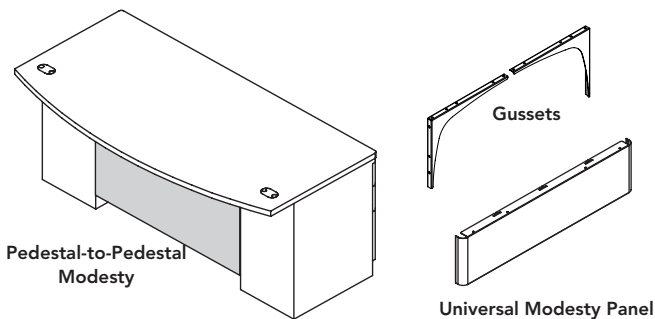

Universal Modesty Panels	Peninsula			P-Shape	Jetty		Boomerang
	60"L	66"L	72"L	72"L	66"L	72"L	72"L
PMP41	•						
PMP47		•		•	•		
PMP53			•			•	•

For specification information see pages 95-110.
For non-standard worksurface sizes see pages 118-119.

GSA SIN 33721

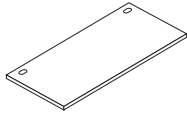

Description	Laminate w/Flat Edge Model	Laminate w/Flat Edge		
		L1 List Price	L2 List Price	L3 List Price
Primary Worksurfaces				
24"W x 20"D	T52024S	\$ 385	\$ 403	\$ 418
30"W x 20"D	T52030S	\$ 408	\$ 427	\$ 442
36"W x 20"D	T52036S	\$ 456	\$ 476	\$ 494
42"W x 20"D	T52042S	\$ 512	\$ 534	\$ 554
48"W x 20"D	T52048S	\$ 553	\$ 576	\$ 597
54"W x 20"D	T52054S	\$ 600	\$ 625	\$ 646
60"W x 20"D	T52060S	\$ 682	\$ 712	\$ 734
66"W x 20"D	T52066S	\$ 739	\$ 771	\$ 795
72"W x 20"D	T52072S	\$ 770	\$ 803	\$ 827
78"W x 20"D	T52078S	\$ 1003	\$ 1044	\$ 1078
84"W x 20"D	T52084S	\$ 1048	\$ 1090	\$ 1126
90"W x 20"D	T52090S	\$ 1239	\$ 1286	\$ 1331
96"W x 20"D	T52096S	\$ 1298	\$ 1347	\$ 1394
24"W x 24"D	T52424S	\$ 407	\$ 426	\$ 441
30"W x 24"D	T52430S	\$ 429	\$ 449	\$ 465
36"W x 24"D	T52436S	\$ 484	\$ 505	\$ 524
42"W x 24"D	T52442S	\$ 540	\$ 562	\$ 583
48"W x 24"D	T52448S	\$ 586	\$ 611	\$ 631
54"W x 24"D	T52454S	\$ 633	\$ 662	\$ 681
60"W x 24"D	T52460S	\$ 718	\$ 749	\$ 771
66"W x 24"D	T52466S	\$ 781	\$ 814	\$ 839
72"W x 24"D	T52472S	\$ 815	\$ 849	\$ 874
78"W x 24"D	T52478S	\$ 1058	\$ 1100	\$ 1136
84"W x 24"D	T52484S	\$ 1109	\$ 1153	\$ 1191
90"W x 24"D	T52490S	\$ 1310	\$ 1359	\$ 1406
96"W x 24"D	T52496S	\$ 1370	\$ 1422	\$ 1472
24"W x 30"D	T53024S	\$ 429	\$ 449	\$ 465
30"W x 30"D	T53030S	\$ 517	\$ 539	\$ 559
36"W x 30"D	T53036S	\$ 556	\$ 579	\$ 600
42"W x 30"D	T53042S	\$ 599	\$ 624	\$ 645
48"W x 30"D	T53048S	\$ 633	\$ 662	\$ 681
54"W x 30"D	T53054S	\$ 707	\$ 738	\$ 760
60"W x 30"D	T53060S	\$ 787	\$ 820	\$ 845
66"W x 30"D	T53066S	\$ 850	\$ 886	\$ 912
72"W x 30"D	T53072S	\$ 922	\$ 960	\$ 989
78"W x 30"D	T53078S	\$ 1197	\$ 1243	\$ 1287
84"W x 30"D	T53084S	\$ 1251	\$ 1298	\$ 1344
90"W x 30"D	T53090S	\$ 1492	\$ 1548	\$ 1603
96"W x 30"D	T53096S	\$ 1540	\$ 1597	\$ 1655



- Notes:**
- 1) Add suffix and upcharge for 24"D and 30"D primary worksurfaces to span a "T" or extended straight connection. Suffix = "TM" for flat edge worksurfaces (Optimize — adds 2 1/4" to width) \$39 upcharge. Examples: T53030STM, T53060STM
 - 2) Add Suffix "N" to model number for no grommet, no upcharge. Example: T53078SN

<p>How to specify — Select the Model Number from above. Prefix T Laminate w/Flat</p>	<p>1st Option: Laminate: See page 68 for finishes.</p>	<p>2nd Option: Edge Trim Color: See page 68 for finishes.</p>	<p>3rd Option: Grommet Type (if applicable): P Oval Plastic (will match edge trim) M Oval Metal (Add \$13 per grommet) S Square Metal (Add \$13 per grommet)</p>	<p>4th Option: Grommet Color (Metal only): EL Matte Silver Note: Plastic grommet color matches trim selection.</p>
<p>_____ . _____ . _____ . _____</p>	<p>_____ . _____ . _____ . _____</p>	<p>_____ . _____ . _____ . _____</p>	<p>_____ . _____ . _____ . _____</p>	<p>E L</p>

Examples: T52424S.LM14.EW.P T53048STMN.LM14.E4

For specification information see pages 95-110.

Laminate

GSA SIN 33721

Description	Laminate w/Flat Edge Model	Laminate w/Flat Edge		
		L1 List Price	L2 List Price	L3 List Price
Bow-Front Worksurfaces				
60"W x 30"D ¹ x 36"D ²	TT53660BT	\$ 1177	\$ 1223	\$ 1266
66"W x 30"D ¹ x 36"D ²	TT53666BT	\$ 1278	\$ 1326	\$ 1372
72"W x 30"D ¹ x 36"D ²	TT53672BT	\$ 1375	\$ 1427	\$ 1477
Note: Add Suffix "N" to model number for no grommet, no upcharge.				
Sample Worksurface				
12"W x 12"D	831212M	\$ 381	\$ 398	\$ 411

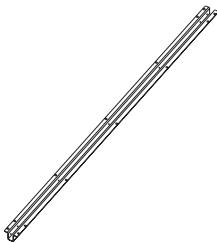
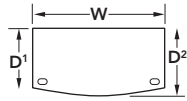
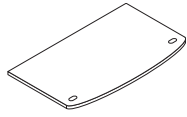

Description	Model	List Price
External Worksurface Support Channel (no color option) — 1 1/2"H		
30"W External Support Channel for use on 42"W Worksurface	Z5SC42 S	\$ 86
36"W External Support Channel for use on 48"W Worksurface	Z5SC48 S	\$ 89
42"W External Support Channel for use on 54"W Worksurface	Z5SC54 S	\$ 102
48"W External Support Channel for use on 60"W Worksurface	Z5SC60	\$ 110
54"W External Support Channel for use on 66"W Worksurface	Z5SC66	\$ 128
60"W External Support Channel for use on 72"W Worksurface	Z5SC72	\$ 137
66"W External Support Channel for use on 78"W Worksurface	Z5SC78	\$ 150
72"W External Support Channel for use on 84"W Worksurface	Z5SC84	\$ 165

OPTIMIZE

<p>How to specify — Select the Model Number from above.</p>	<p>1st Option: Laminate (if applicable): See page 68 for finishes.</p>	<p>2nd Option: Edge Trim Color (if applicable): See page 68 for finishes.</p>	<p>3rd Option: Grommet Type (if applicable): P Oval Plastic (will match edge trim) M Oval Metal (Add \$13 per grommet) S Square Metal (Add \$13 per grommet)</p>	<p>4th Option: Grommet Color (Metal only) (if applicable): EL Matte Silver Note: Plastic grommet color matches trim selection.</p>
<p>_____ . _____ . _____ . _____</p>	<p>_____ . _____ . _____ . _____</p>	<p>_____ . _____ . _____ . _____</p>	<p>_____ . _____ . _____ . _____</p>	<p>E L</p>

Examples: TT53660BT.LT3B.EV.P 831212M.LT3B.EX.P Z5SC42

S Shippable by small-package carrier.

Worksurfaces

Optimize™ — Corner / 120° / 60° / Shelf

For specification information see pages 95-110.

Laminate

GSA SIN 33721

Description	Laminate w/Flat Edge Model	Laminate w/Flat Edge		
		L1 List Price	L2 List Price	L3 List Price
24"D Corner Worksurfaces w/Straight Leading Edge				
36"W	T53624SC	\$ 715	\$ 746	\$ 775
42"W	T54224SC	\$ 754	\$ 786	\$ 816
48"W	T54824SC	\$ 853	\$ 889	\$ 925
30"D Corner Worksurfaces w/Straight Leading Edge				
42"W	T54230SC	\$ 932	\$ 972	\$ 1010
48"W	T54830SC	\$ 964	\$ 1005	\$ 1044
60° Pie Worksurface				
24"D	TN52424SD	\$ 663	\$ 693	\$ 713
Corner Shelves with Flat Edge				
36" x 36" x 11"D	860536M	\$ 734	\$ 764	\$ 784
42" x 42" x 11"D	860542M	\$ 779	\$ 810	\$ 832
48" x 48" x 11"D	860548M	\$ 828	\$ 860	\$ 885

Note: Add Suffix "N" to model number for no grommet, no upcharge.

Corner Worksurfaces with Radial Leading Edge

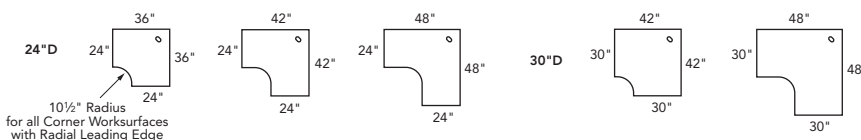

Corner Worksurfaces with Straight Leading Edge

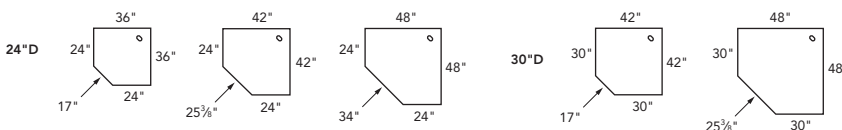

<p>How to specify — Select the Model Number from above.</p>	<p>1st Option: Laminate: See page 68 for finishes.</p>	<p>2nd Option: Paint (Corner Shelves only): P1 P2 P3 See page 68 for finishes.</p>	<p>2nd Option: Edge Trim Color: See page 68 for finishes.</p>	<p>3rd Option: Grommet Type (if applicable): P Oval Plastic (will match edge trim) M Oval Metal (Add \$13 per grommet) S Square Metal (Add \$13 per grommet)</p>	<p>4th Option: Grommet Color (Metal only): EL Matte Silver Note: Plastic grommet color matches trim selection.</p>
<p>_____ . _____ . P _____</p>					<p>E L </p>

Examples: T53624SC.LT3B.EV.MEL 860536M.LT3B.P27.E4

For specification information see pages 95-110.

Laminate

GSA SIN 33721

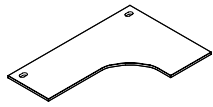

Description	Laminate w/Flat Edge Model	Laminate w/Flat Edge		
		L1 List Price	L2 List Price	L3 List Price
Corner Cove Worksurfaces — Extended Left				
60" x 36" — 24"L / 24"R	T5822EL	\$ 856	\$ 894	\$ 927
60" x 36" — 24"L / 30"R	T5832EL	\$ 897	\$ 937	\$ 970
60" x 48" — 24"L / 24"R	T5622EL	\$ 959	\$ 1001	\$ 1036
60" x 48" — 30"L / 24"R	T5623EL	\$ 1004	\$ 1047	\$ 1085
60" x 48" — 24"L / 30"R	T5632EL	\$ 1004	\$ 1047	\$ 1085
60" x 48" — 30"L / 30"R	T5633EL	\$ 1041	\$ 1085	\$ 1125
72" x 36" — 24"L / 24"R	T5922EL	\$ 959	\$ 1001	\$ 1036
72" x 36" — 24"L / 30"R	T5932EL	\$ 1004	\$ 1047	\$ 1085
72" x 48" — 24"L / 24"R	T5722EL	\$ 1243	\$ 1292	\$ 1339
72" x 48" — 30"L / 24"R	T5723EL	\$ 1288	\$ 1338	\$ 1390
72" x 48" — 24"L / 30"R	T5732EL	\$ 1288	\$ 1338	\$ 1390
72" x 48" — 30"L / 30"R	T5733EL	\$ 1326	\$ 1379	\$ 1432

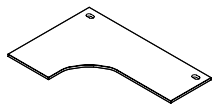

Corner Cove Worksurfaces — Extended Right				
36" x 60" — 24"L / 24"R	T5822ER	\$ 856	\$ 894	\$ 927
36" x 60" — 30"L / 24"R	T5832ER	\$ 897	\$ 937	\$ 970
48" x 60" — 24"L / 24"R	T5622ER	\$ 959	\$ 1001	\$ 1036
48" x 60" — 24"L / 30"R	T5623ER	\$ 1004	\$ 1047	\$ 1085
48" x 60" — 30"L / 24"R	T5632ER	\$ 1004	\$ 1047	\$ 1085
48" x 60" — 30"L / 30"R	T5633ER	\$ 1041	\$ 1085	\$ 1125
36" x 72" — 24"L / 24"R	T5922ER	\$ 959	\$ 1001	\$ 1036
36" x 72" — 30"L / 24"R	T5932ER	\$ 1004	\$ 1047	\$ 1085
48" x 72" — 24"L / 24"R	T5722ER	\$ 1243	\$ 1292	\$ 1339
48" x 72" — 24"L / 30"R	T5723ER	\$ 1288	\$ 1338	\$ 1390
48" x 72" — 30"L / 24"R	T5732ER	\$ 1288	\$ 1338	\$ 1390
48" x 72" — 30"L / 30"R	T5733ER	\$ 1326	\$ 1379	\$ 1432

Note: Add Suffix "N" to model number for no grommet, no upcharge.

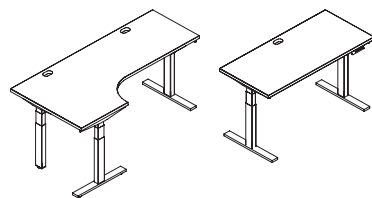
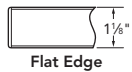

Note: Freestanding Altitude electric height-adjustable tables are available to order in Seating, Collaboration, and Tables price list.

<p>How to specify — Select the Model Number from above.</p>	<p>1st Option: Laminate: See page 68 for finishes.</p>	<p>2nd Option: Edge Trim Color: See page 68 for finishes.</p>	<p>3rd Option: Grommet Type: P Oval Plastic (will match edge trim) M Oval Metal (Add \$13 per grommet) S Square Metal (Add \$13 per grommet)</p>	<p>4th Option: Grommet Color (Metal only): EL Matte Silver Note: Plastic grommet color matches trim selection.</p>
<p>Examples: T5822EL.LT3B.EY.MEL T5822EL.LT3B.EV.P</p>				<p>E L</p>

OPTIMIZE



Worksurfaces

Optimize™ — Peninsula / P-Shaped / Jetty

Laminate

GSA SIN 33721

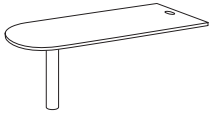
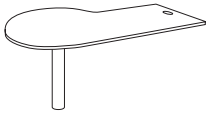
For specification information see pages 95-110.

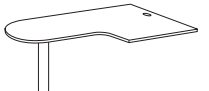
Support column ordered separately.	Description	Laminate w/Flat Edge Model	Laminate w/Flat Edge		
			L1 List Price	L2 List Price	L3 List Price
	Peninsula Worksurfaces				
	60"L x 30"W	T53060B	\$ 1077	\$ 1120	\$ 1158
	66"L x 30"W	T53066B	\$ 1190	\$ 1236	\$ 1280
	72"L x 30"W	T53072B	\$ 1298	\$ 1347	\$ 1394
	60"L x 36"W	T53660B	\$ 796	\$ 845	\$ 892
	66"L x 36"W	T53666B	\$ 853	\$ 907	\$ 961
	P-Shaped Worksurfaces w/42" Diameter End				
	72"L x 30"W (Left hand)	T53072PR	\$ 1488	\$ 1544	\$ 1600
	72"L x 30"W (Right hand)	T53072PL	\$ 1488	\$ 1544	\$ 1600
	Jetty Worksurfaces — Left Hand				
	48"A x 66"B x 24"C x 30"D	T54662JL	\$ 1243	\$ 1296	\$ 1349
	48"A x 72"B x 24"C x 30"D	T54722JL	\$ 1326	\$ 1379	\$ 1433
	48"A x 66"B x 30"C x 30"D	T54663JL	\$ 1288	\$ 1342	\$ 1397
	48"A x 72"B x 30"C x 30"D	T54723JL	\$ 897	\$ 953	\$ 1009
	Jetty Worksurfaces — Right Hand				
	48"A x 66"B x 24"C x 30"D	T54662JR	\$ 1243	\$ 1296	\$ 1349
	48"A x 72"B x 24"C x 30"D	T54722JR	\$ 1326	\$ 1379	\$ 1433
	48"A x 66"B x 30"C x 30"D	T54663JR	\$ 1288	\$ 1342	\$ 1397
	48"A x 72"B x 30"C x 30"D	T54723JR	\$ 897	\$ 953	\$ 1009

Note: Add Suffix "N" to model number for no grommet, no upcharge.

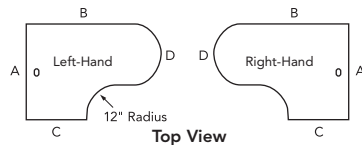

<p>How to specify — Select the Model Number from above.</p>	<p>1st Option: Laminate: See page 68 for finishes.</p>	<p>2nd Option: Edge Trim Color: See page 68 for finishes.</p>	<p>3rd Option: Grommet Type: P Oval Plastic (will match edge trim) M Oval Metal (Add \$13 per grommet) S Square Metal (Add \$13 per grommet)</p>	<p>4th Option: Grommet Color (Metal only): EL Matte Silver Note: Plastic grommet color matches trim selection.</p>
<p>Examples: T53060B.LT3B.EV.P T54662JL.LT3B.EV.MEL</p>				<p>E L</p>

Worksurfaces

Optimize™ — Quarter-Round / D-Shaped

For specification information see pages 95-110.

Laminate

GSA SIN 33721

Support column ordered separately.



Support column and flat brackets ordered separately.

Description	Laminate w/Flat Edge Model	Laminate w/Flat Edge		
		L1 List Price	L2 List Price	L3 List Price
Quarter-Round Worksurfaces (outside corner connecting two 90° panel-attached worksurfaces)				
24"D x 24"D	802424M	\$ 603	\$ 626	\$ 647
30"D x 30"D	803030M	\$ 760	\$ 791	\$ 812

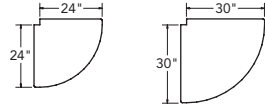

D-Shaped Worksurfaces

Connects to two 24"D Worksurfaces	832407M	\$ 1162	\$ 1204	\$ 1241
Connects to two 30"D Worksurfaces	833007M	\$ 1352	\$ 1399	\$ 1444

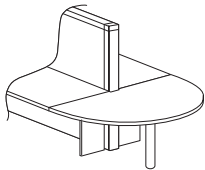

Support column and 11" end panels ordered separately.

Note: Cantilever brackets should not be used in place of end panels in this application.

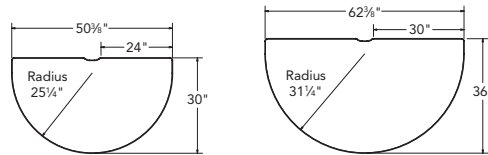

832407M

833007M



Flat Edge

How to specify —
Select the Model Number from above.

1st Option:
Laminate:
See page 68 for finishes.

2nd Option:
Edge Trim Color:
See page 68 for finishes.

Examples: 802424M.LT3B.EV 832407M.LT3B.EV

For specification information see pages 95-110.

Laminate

GSA SIN 33721

Description	Model	P1 Paint	P2 Paint	P3 Paint
		List Price	List Price	List Price
Countertop Brackets — Straight countertops require 2 sets; corner countertops 3 sets				
For 35"H and 50"H Panels — 1 each right-hand and left-hand	P51500	\$ 55	\$ 67	\$ 75
For 42½"H Panels — 1 each right-hand and left-hand	P51500-42	\$ 55	\$ 67	\$ 75

Description	Laminate w/Flat Edge Model	Laminate w/Flat Edge		
		L1 List Price	L2 List Price	L3 List Price
Straight Countertops — must order 2 sets of brackets per surface				
24"W x 15"D	851524M	\$ 387	\$ 405	\$ 418
30"W x 15"D	851530M	\$ 429	\$ 448	\$ 462
36"W x 15"D	851536M	\$ 482	\$ 502	\$ 519
42"W x 15"D	851542M	\$ 499	\$ 519	\$ 537
48"W x 15"D	851548M	\$ 528	\$ 549	\$ 568
54"W x 15"D	851554M	\$ 598	\$ 621	\$ 641
60"W x 15"D	851560M	\$ 667	\$ 687	\$ 704
66"W x 15"D	851566M	\$ 691	\$ 720	\$ 739
72"W x 15"D	851572M	\$ 718	\$ 748	\$ 767

Corner Countertops 15"D at ends — must order 3 sets of brackets per surface				
24"W x 24"W	852424M	\$ 754	\$ 785	\$ 806
30"W x 30"W	853030M	\$ 877	\$ 911	\$ 936
36"W x 36"W	853636M	\$ 973	\$ 1010	\$ 1039
42"W x 42"W	854242M	\$ 1056	\$ 1096	\$ 1129

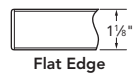

<p>How to specify — Select the Model Number from above.</p>	<p><i>1st Option:</i> Laminate (Countertops only): See page 68 for finishes.</p>	<p><i>1st Option:</i> Paint (for Brackets only): P1 P2 P3 See page 68 for finishes.</p>	<p><i>2nd Option:</i> Edge Trim Color (Countertops only): See page 68 for finishes.</p>
--	---	--	--

Examples: 851524M.LT3B.EX P51500.P02

ORDERING

The 9120 Program can be used to order particle board rectangular worksurfaces in any non-standard width and depth in 1/8" increments up to a maximum of 120" W x 36" D.

Specify:

- Model Number**
Specify closest nominal width/depth model (round up).
- Grommet Option** (if desired)
See grommet specification instructions on this page.
- Grommet Type:**
P Plastic
M Metal (add \$13 per grommet for laminate)
- Grommet Color:**
(Metal only)
EL Matte Silver
NOTE: Plastic grommet will match flat edge.
- Laminate Choices**
See page 68.
- Flat Edge Color Choices**
See EDGE COLORS page 68 for laminates.
- Exact Size**
Specify the **EXACT Width** and **EXACT Depth** you require.
Width and depth is specified in 1/8" increments which is denoted as a single digit following the whole number dimension at the end of the model number string.

1/8" = 1	5/8" = 5
2/8" = 2	6/8" = 6
3/8" = 3	7/8" = 7
4/8" = 4	no extra increment = 0

For example, when ordering a worksurface that is 34 3/8" W x 20 1/2" D, specification should be 345Wx204D.
Example: 9120R3624.G0.TM33.EU.345Wx204D.

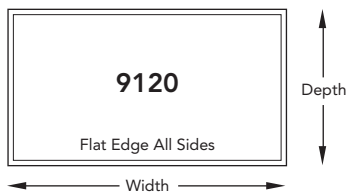

PRODUCT SPECIFICATIONS

- Flat Edge on all sides
- 45 lb. particle board
- 1 1/8" top thickness
- .020 resin impregnated paper backer sheet
- Grommets available
- Maximum width 120" (maximum recommended unsupported span is 42")
- Maximum depth 36"
- Standard Allsteel laminates
- Quantities of 10 or greater are palletized; less than 10 are individually cartoned.

Note: 9120 worksurface maximum unsupported span is 42". 9120 worksurfaces do not have pre-drilled pilot holes or threaded metal inserts.

When spanning multiple freestanding storage units with one worksurface, add 1/8" for each additional storage unit. For example, when ordering a worksurface for three 30"W lateral files. 3 units x 30" = 90" + 1/8" + 1/8" = 90 1/4" worksurface. Do NOT follow this rule if panel wrapping storage units.

CHANGES / CANCELLATIONS

No changes/cancellations for 9120 Program Worksurfaces.

GROMMET SPECIFICATIONS

Plastic grommets are made of durable ABS plastic and grommets match edge color on laminate worksurfaces. Metal grommets are only available Matte Silver oval for laminate.

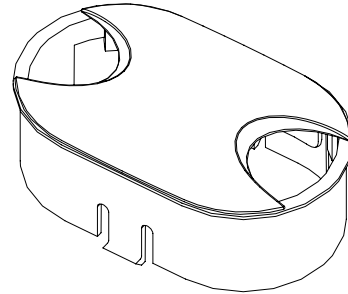

PRICING

One Grommet – GC, GL, or GR Position \$20.00
Two Grommets – G3 or G4 Position..... \$40.00
NOTE: Add \$13 per grommet for Metal grommets with laminate.

ORDERING

Specify grommet location and color.
Example: 9120R10836.GCP.TM33.EU.1022Wx326D

Code Grommet Position

- GC Centered side-to-side – 3/8" from rear to grommet edge; 4 1/2" from rear to grommet center
- GL 6 1/16" from left side to grommet edge – 3/8" from rear to grommet edge; 4 1/2" from rear to grommet center
- GR 6 1/16" from right side to grommet edge – 3/8" from rear to grommet edge; 4 1/2" from rear to grommet center
- G3 Pair of grommets each 18" from side edge – 3/8" from rear to grommet edge; 4 1/2" from rear to grommet center (Position G3 not available on tops 60"W or less.)
- G4 Pair of grommets each 6 1/16" from side edge to grommet edge – 3/8" from rear to grommet edge; 4 1/2" from rear to grommet center
- G0 No grommets

Dimensions are from grommet center line to top edge.

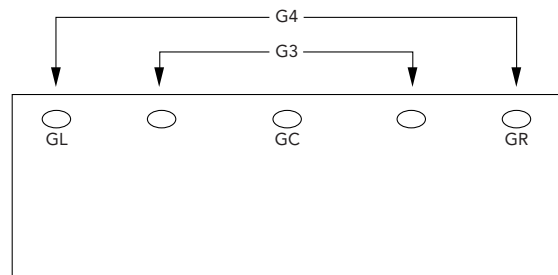

Rectangular Top

Grommet positions other than those shown above are considered non-standard.

Maximum	Model Number*	Width		Depth		Laminate List Price		
		MIN	MAX	MIN	MAX	L1	L2	L3
18"D								
18"W	9120R1818	180W	180W	121D	180D	\$ 468	\$ 489	\$ 506
24"W	9120R2418	181W	240W	121D	180D	\$ 489	\$ 510	\$ 529
30"W	9120R3018	241W	300W	121D	180D	\$ 535	\$ 557	\$ 576
36"W	9120R3618	301W	360W	121D	180D	\$ 556	\$ 579	\$ 600
42"W	9120R4218	361W	420W	121D	180D	\$ 643	\$ 668	\$ 690
48"W	9120R4818	421W	480W	121D	180D	\$ 709	\$ 740	\$ 762
60"W	9120R6018	481W	600W	121D	180D	\$ 925	\$ 962	\$ 990
72"W	9120R7218	601W	720W	121D	180D	\$ 1119	\$ 1161	\$ 1198
84"W	9120R8418	721W	840W	121D	180D	\$ 1463	\$ 1515	\$ 1569
96"W	9120R9618	841W	960W	121D	180D	\$ 1513	\$ 1567	\$ 1621
108"W	9120R10818	961W	1080W	121D	180D	\$ 1730	\$ 1790	\$ 1853
120"W	9120R12018	1081W	1200W	121D	180D	\$ 1877	\$ 1948	\$ 2018
24"D								
24"W	9120R2424	181W	240W	181D	240D	\$ 531	\$ 553	\$ 574
30"W	9120R3024	241W	300W	181D	240D	\$ 580	\$ 603	\$ 624
36"W	9120R3624	301W	360W	181D	240D	\$ 605	\$ 630	\$ 651
42"W	9120R4224	361W	420W	181D	240D	\$ 695	\$ 725	\$ 744
48"W	9120R4824	421W	480W	181D	240D	\$ 750	\$ 782	\$ 806
60"W	9120R6024	481W	600W	181D	240D	\$ 971	\$ 1009	\$ 1042
72"W	9120R7224	601W	720W	181D	240D	\$ 1162	\$ 1206	\$ 1244
84"W	9120R8424	721W	840W	181D	240D	\$ 1513	\$ 1567	\$ 1621
96"W	9120R9624	841W	960W	181D	240D	\$ 1488	\$ 1544	\$ 1600
108"W	9120R10824	961W	1080W	181D	240D	\$ 1780	\$ 1842	\$ 1907
120"W	9120R12024	1081W	1200W	181D	240D	\$ 1920	\$ 1992	\$ 2065
30"D								
30"W	9120R3030	241W	300W	241D	300D	\$ 638	\$ 667	\$ 686
36"W	9120R3630	301W	360W	241D	300D	\$ 671	\$ 701	\$ 721
42"W	9120R4230	361W	420W	241D	300D	\$ 715	\$ 746	\$ 768
48"W	9120R4830	421W	480W	241D	300D	\$ 774	\$ 807	\$ 832
60"W	9120R6030	481W	600W	241D	300D	\$ 1016	\$ 1056	\$ 1089
72"W	9120R7230	601W	720W	241D	300D	\$ 1161	\$ 1206	\$ 1247
84"W	9120R8430	721W	840W	241D	300D	\$ 1763	\$ 1828	\$ 1894
96"W	9120R9630	841W	960W	241D	300D	\$ 1805	\$ 1871	\$ 1939
108"W	9120R10830	961W	1080W	241D	300D	\$ 2033	\$ 2108	\$ 2186
120"W	9120R12030	1081W	1200W	241D	300D	\$ 2265	\$ 2350	\$ 2434
36"D								
36"W	9120R3636	301W	360W	301D	360D	\$ 911	\$ 948	\$ 978
42"W	9120R4236	361W	420W	301D	360D	\$ 1035	\$ 1077	\$ 1112
48"W	9120R4836	421W	480W	301D	360D	\$ 1163	\$ 1208	\$ 1249
60"W	9120R6036	481W	600W	301D	360D	\$ 1498	\$ 1551	\$ 1605
72"W	9120R7236	601W	720W	301D	360D	\$ 1764	\$ 1826	\$ 1889
84"W	9120R8436	721W	840W	301D	360D	\$ 2135	\$ 2210	\$ 2288
96"W	9120R9636	841W	960W	301D	360D	\$ 2188	\$ 2266	\$ 2343
108"W	9120R10836	961W	1080W	301D	360D	\$ 2426	\$ 2512	\$ 2601
120"W	9120R12036	1081W	1200W	301D	360D	\$ 2538	\$ 2632	\$ 2729

For specification information see pages 95-101.

GSA SIN 33721

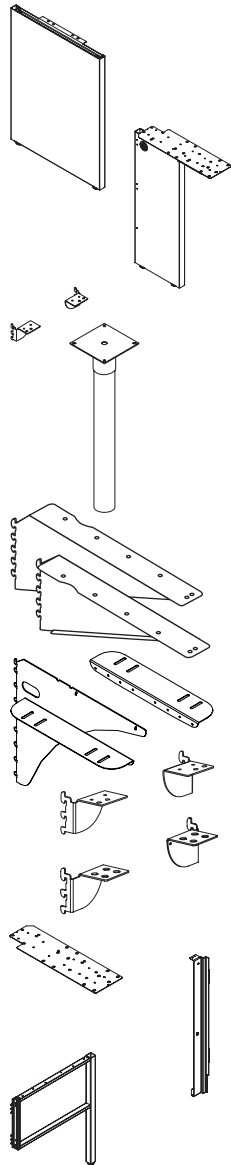

Description	Model	P1 Paint List Price	P2 Paint List Price	P3 Paint List Price
End-Panel Supports				
11"D x 29½"H — Left – Panel-Mount	TKEP1129PL	\$ 286	\$ 328	\$ 369
11"D x 29½"H — Right – Panel-Mount	TKEP1129PR	\$ 286	\$ 328	\$ 369
24"D x 29½"H — Left – Panel-Mount	TKEP2429PL	\$ 305	\$ 347	\$ 388
24"D x 29½"H — Right – Panel-Mount	TKEP2429PR	\$ 305	\$ 347	\$ 388
30"D x 29½"H — Left – Panel-Mount	TKEP3029PL	\$ 334	\$ 376	\$ 417
30"D x 29½"H — Right – Panel-Mount	TKEP3029PR	\$ 334	\$ 376	\$ 417
Support Legs				
24"D x 29½"H — Panel-Mount	TKSL2429P	\$ 269	\$ 311	\$ 352
30"D x 29½"H — Panel-Mount	TKSL3029P	\$ 294	\$ 336	\$ 377
Support Columns				
29½"H / 3" Diameter	TT629SC S	\$ 257	\$ 299	\$ 340
Cantilever Brackets				
12"D Left-Hand	T6CB12L S	\$ 72	\$ 89	\$ 101
12"D Right-Hand	T6CB12R S	\$ 72	\$ 89	\$ 101
18"D Left-Hand	T6CB18L S	\$ 77	\$ 94	\$ 106
18"D Right-Hand	T6CB18R S	\$ 77	\$ 94	\$ 106
24" or 30"D Left-Hand	T6CB24L S	\$ 84	\$ 101	\$ 113
24" or 30"D Right-Hand	T6CB24R S	\$ 84	\$ 101	\$ 113
Cantilever Bracket — non-handed (Core paint colors only)				
24" or 30"D	T624CB S	\$ 228	N/A	N/A
Worksurface Bracket Kit				
One pair	T6BK S	\$ 73	\$ 89	\$ 100
Worksurface Storage Bracket Kit (no color option)				
One Pair	T6SB S	\$ 98	N/A	N/A
Flat Brackets (no color option)				
For 12"D	T612FB S	\$ 70	N/A	N/A
For 24"D	T624FB S	\$ 80	N/A	N/A
For 30"D	T630FB S	\$ 91	N/A	N/A
Pedestal-to-Panel Bracket				
Left	TKPPBL S	\$ 121	\$ 138	\$ 150
Right	TKPPBR	\$ 121	\$ 138	\$ 150
Open End Panel Supports				
12"D x 29½"H Panel-Mount	AYBHEP1229	\$ 282	\$ 324	\$ 365
18"D x 29½"H Panel-Mount	AYBHEP1829	\$ 287	\$ 329	\$ 370
24"D x 29½"H Panel-Mount	AYBHEP2429	\$ 297	\$ 339	\$ 380
30"D x 29½"H Panel-Mount	AYBHEP3029	\$ 320	\$ 362	\$ 403

How to specify —
Select the Model Number from above.

1st Option:
Paint
(if applicable):
P1 P2 P3
See page 68 for finishes.

_____ . P _____

Examples: TKEP1129PL.P02 T6SB

S Shippable by small-package carrier.

For specification information see pages 102-110.

GSA SIN 33721

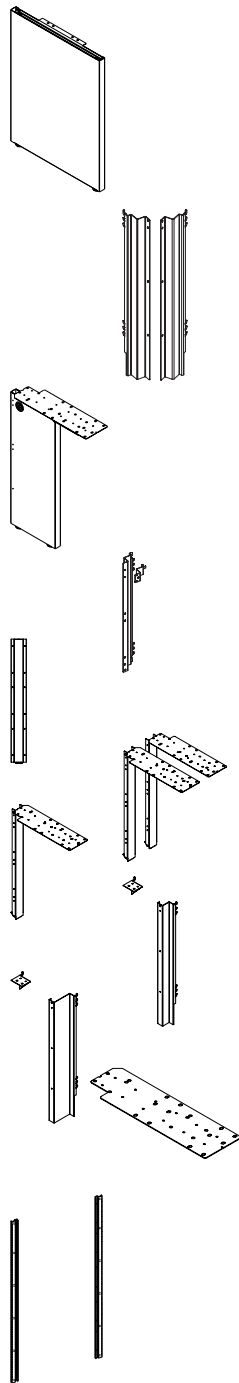

Description	Model	P1 Paint List Price	P2 Paint List Price	P3 Paint List Price
End-Panel Supports				
11"D x 29½"H — Freestanding	CEP1129F	\$ 277	\$ 319	\$ 360
24"D x 29½"H — Freestanding	CEP2429F	\$ 297	\$ 339	\$ 380
30"D x 29½"H — Freestanding	CEP3029F	\$ 329	\$ 371	\$ 412
<hr/>				
11"D x 29½"H — Left – Panel-Mount	TKEP1129PL	\$ 286	\$ 328	\$ 369
11"D x 29½"H — Right – Panel-Mount	TKEP1129PR	\$ 286	\$ 328	\$ 369
24"D x 29½"H — Left – Panel-Mount	TKEP2429PL	\$ 305	\$ 347	\$ 388
24"D x 29½"H — Right – Panel-Mount	TKEP2429PR	\$ 305	\$ 347	\$ 388
30"D x 29½"H — Left – Panel-Mount	TKEP3029PL	\$ 334	\$ 376	\$ 417
30"D x 29½"H — Right – Panel-Mount	TKEP3029PR	\$ 334	\$ 376	\$ 417
<hr/>				
End-Panel Bracket Kits for Optimize				
29½"H Bracket Kit — Left	TKEB29L	\$ 58	\$ 75	\$ 87
29½"H Bracket Kit — Right	TKEB29R	\$ 58	\$ 75	\$ 87
<hr/>				
Support Legs				
24"D x 29½"H — Freestanding	CSL2429F S	\$ 257	\$ 299	\$ 340
30"D x 29½"H — Freestanding	CSL3029F S	\$ 285	\$ 327	\$ 368
<hr/>				
24"D x 29½"H — Panel-Mount	TKSL2429P	\$ 269	\$ 311	\$ 352
30"D x 29½"H — Panel-Mount	TKSL3029P	\$ 294	\$ 336	\$ 377
<hr/>				
Support Leg Bracket for Optimize				
29½"H	TKSB29	\$ 58	\$ 75	\$ 87
<hr/>				
Corner Desk Leg				
29½"H	CDL29 S	\$ 236	\$ 261	\$ 283
<hr/>				
Bridge Kit				
29½"H	CBK29 S	\$ 248	\$ 265	\$ 277
<hr/>				
Return Kit				
29½"H	CRK29 S	\$ 127	\$ 140	\$ 149
<hr/>				
Desk-to-Panel Attachment Kits for Optimize				
29½"H – Left-Hand	TKDPA29L	\$ 115	\$ 132	\$ 144
29½"H – Right-Hand	TKDPA29R	\$ 115	\$ 132	\$ 144
<hr/>				
Corner w/Desk Panel Attachment Kit for Optimize				
29½"H – Left-Hand	TKCWD29L	\$ 115	\$ 132	\$ 144
29½"H – Right-Hand	TKCWD29R	\$ 115	\$ 132	\$ 144
<hr/>				
Flat Brackets				
24"D	831124 S	\$ 79	N/A	N/A
30"D	831130 S	\$ 86	N/A	N/A
<hr/>				
Note: Flint only.				
<hr/>				
Optimize Wall Track Kit — End/Shared				
65"H — Pair of Ends	TK365YEB S	\$ 353	\$ 402	\$ 452
65"H — Middle Unit	TK365YM S	\$ 184	\$ 213	\$ 239

How to specify —
Select the Model Number from above.

1st Option:
Paint:
P1 P2 P3
See page 68 for finishes.

_____ . **P** _____

Examples: CEP1129F.P02 831124

S Shippable by small-package carrier.

For specification information see pages 102-110.

GSA SIN 33721

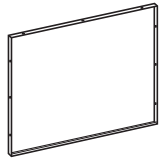

Description	Model	P1 Paint List Price	P2 Paint List Price	P3 Paint List Price
Modesty Panels				
29½"H x 24"W	CS249 <input type="checkbox"/>	\$ 268	\$ 293	\$ 315
29½"H x 30"W	CS309 <input type="checkbox"/>	\$ 277	\$ 302	\$ 324
29½"H x 36"W	CS369 <input type="checkbox"/>	\$ 283	\$ 308	\$ 330
29½"H x 42"W	CS429 <input type="checkbox"/>	\$ 289	\$ 314	\$ 336
29½"H x 48"W	CS489 <input type="checkbox"/>	\$ 294	\$ 319	\$ 341
29½"H x 54"W	CS549 <input type="checkbox"/>	\$ 297	\$ 322	\$ 344
29½"H x 60"W	CS609	\$ 302	\$ 327	\$ 349
29½"H x 66"W	CS669	\$ 307	\$ 332	\$ 354
29½"H x 72"W	CS729	\$ 319	\$ 344	\$ 366

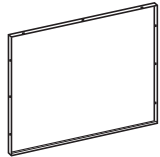

Stand-alone Corner Modesty Panels				
29½"H x 36"W	CSCMP3629 <input type="checkbox"/>	\$ 283	\$ 308	\$ 330
29½"H x 42"W	CSCMP4229 <input type="checkbox"/>	\$ 289	\$ 314	\$ 336
29½"H x 48"W	CSCMP4829 <input type="checkbox"/>	\$ 294	\$ 319	\$ 341
29½"H x 60"W	CSCMP6029	\$ 302	\$ 327	\$ 349
29½"H x 72"W	CSCMP7229	\$ 319	\$ 344	\$ 366

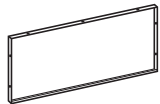

Modesty Panels				
14"H x 24"W	CS244 <input type="checkbox"/>	\$ 253	\$ 278	\$ 300
14"H x 30"W	CS304 <input type="checkbox"/>	\$ 258	\$ 283	\$ 305
14"H x 36"W	CS364 <input type="checkbox"/>	\$ 265	\$ 290	\$ 312
14"H x 42"W	CS424 <input type="checkbox"/>	\$ 272	\$ 297	\$ 319
14"H x 48"W	CS484 <input type="checkbox"/>	\$ 282	\$ 307	\$ 329
14"H x 54"W	CS544 <input type="checkbox"/>	\$ 285	\$ 310	\$ 332
14"H x 60"W	CS604	\$ 294	\$ 319	\$ 341
14"H x 66"W	CS664	\$ 297	\$ 322	\$ 344
14"H x 72"W	CS724	\$ 302	\$ 327	\$ 349

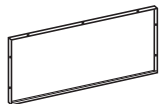

Stand-alone Corner Modesty Panels				
14"H x 36"W	CSCMP3614 <input type="checkbox"/>	\$ 265	\$ 290	\$ 312
14"H x 42"W	CSCMP4214 <input type="checkbox"/>	\$ 272	\$ 297	\$ 319
14"H x 48"W	CSCMP4814 <input type="checkbox"/>	\$ 282	\$ 307	\$ 329
14"H x 60"W	CSCMP6014	\$ 294	\$ 319	\$ 341
14"H x 72"W	CSCMP7214	\$ 302	\$ 327	\$ 349

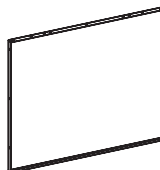

Pedestal-to-Pedestal Modesty Panel				
27"H x 30"W to create a 60"W Desk	TKMP60	\$ 259	\$ 284	\$ 306
27"H x 36"W to create a 66"W Desk	TKMP66	\$ 261	\$ 286	\$ 308
27"H x 42"W to create a 72"W Desk	TKMP72	\$ 270	\$ 295	\$ 317

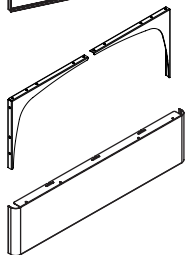

Gussets				
One pair	CDG <input type="checkbox"/>	\$ 193	\$ 218	\$ 240

Modesty Panels				
41"W for 60"L Peninsula	PMP41 <input type="checkbox"/>	\$ 371	\$ 371	\$ 371
47"W for 66"L Peninsula, 72"L P-Shape, or 66"L Jetty	PMP47 <input type="checkbox"/>	\$ 379	\$ 379	\$ 379
53"W for 72"L Peninsula, Jetty, or Boomerang	PMP53 <input type="checkbox"/>	\$ 391	\$ 391	\$ 391

How to specify —
Select the Model Number from above.

1st Option:

Paint:



See page 68 for finishes.

. P

Examples: TKMP60.P4J CS244.P28

Shippable by small-package carrier.

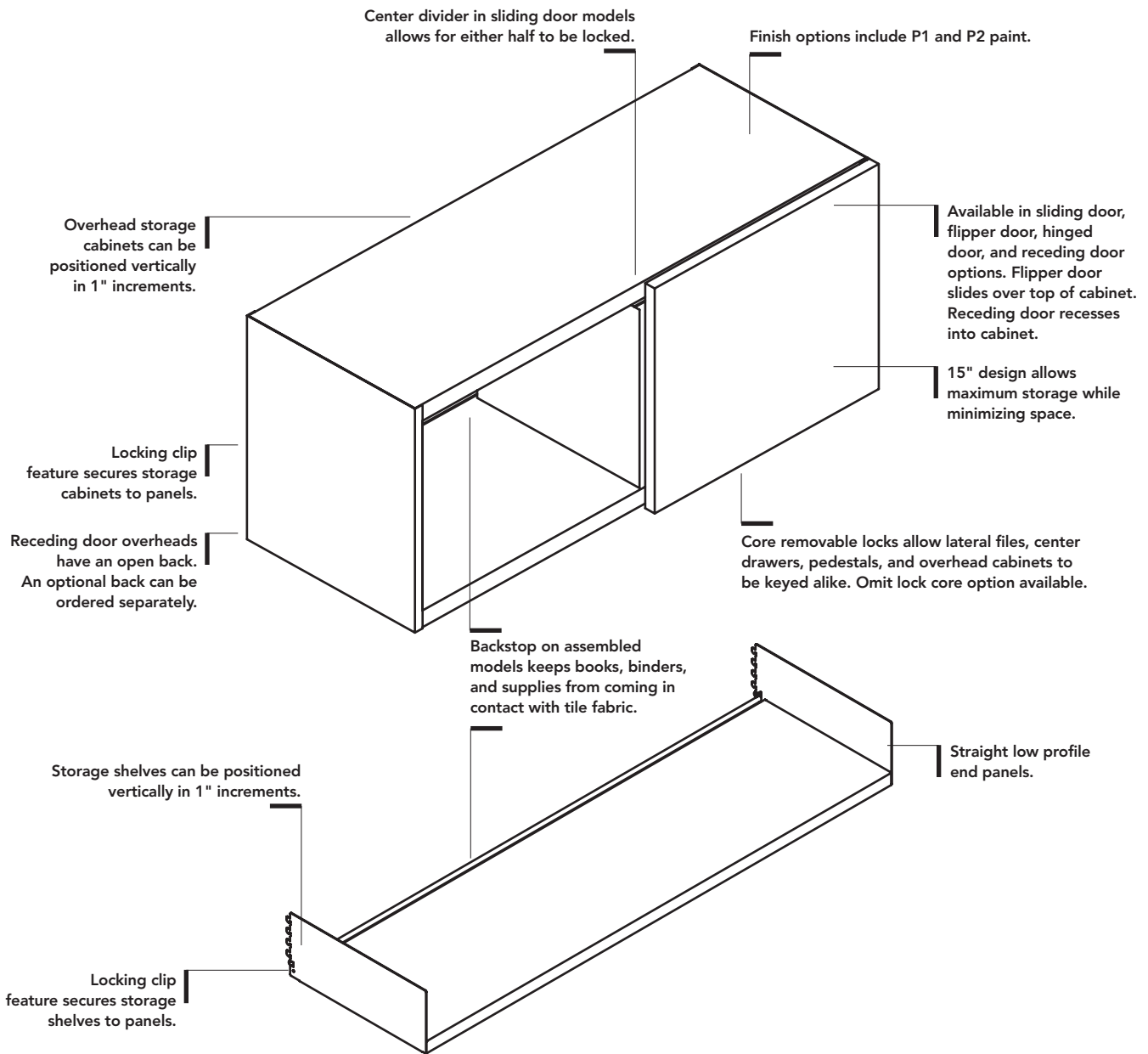

Product dimensions	
Overhead Storage Cabinet	
Width	24", 30", 36", 42", 48", 60", and 72"
Inside width	Flipper or 24"-36"W Hinged door — 3/8" less than width 42"-48"W Hinged or Sliding door — two compartments that are half of 3/8" less than width
Depth	14 1/4" RTA models 12"
Inside depth	12 7/8" Receding door 12 1/2" RTA models 11 5/8"
Height	15"
Inside height	12 3/4" Receding door 11 5/8" RTA models 12 3/4"
Open Shelf	
Width	24", 30", 36", 42", 48", 60", and 72"
Depth	12 7/8" RTA models 11 1/2"
Height	4 5/8" RTA models 5 5/8"

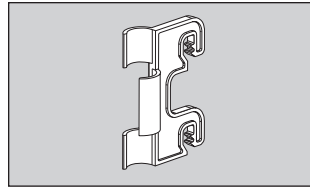
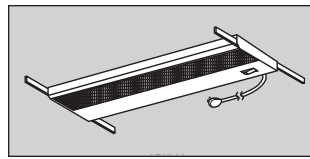

- **Task lights** can be mounted beneath storage shelves and overhead storage cabinets.
- Additional panel hung and freestanding lighting options are available.
- **Cord retainer clips** fasten into panel slots to anchor power cords.
- Available in black only.
- Clips are provided with under-shelf mounted task lights. Additional clips can be purchased separately.

OPTIMIZE

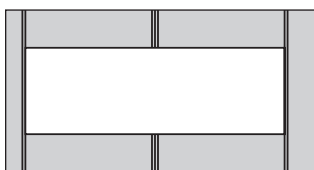
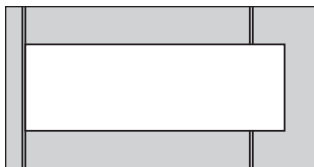
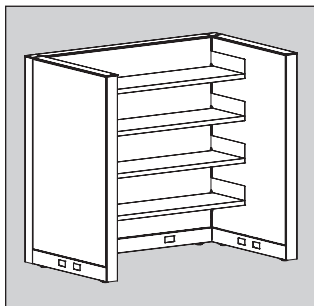
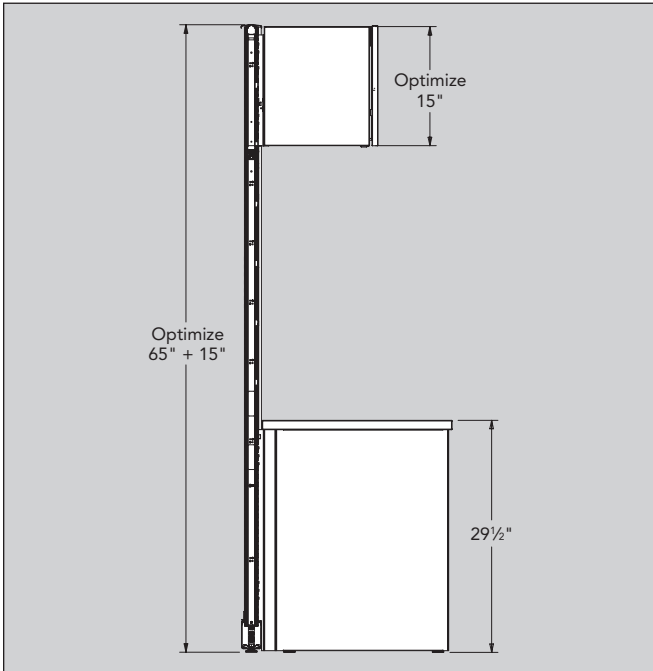
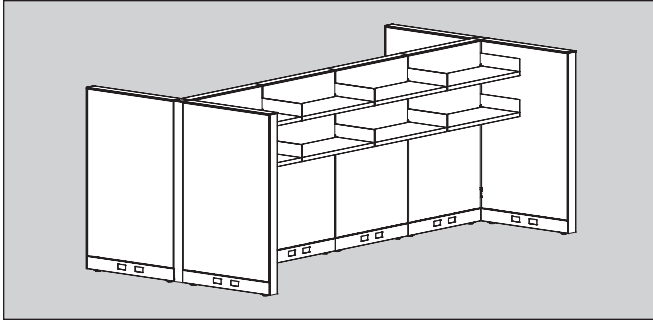

Specification Guidelines

- In a panel run, only two overhead storage cabinets or open storage shelves are recommended per panel side.
- Overhead storage cabinets and open storage shelves can be mounted on Optimize structural and stacking panels to a maximum height of 80"H.
- Base panel frames with stacking frames that have an overall height of 57½" will not accept overhead storage cabinets if spanning between stacker and base panel.
- Immediate adjacent panels must be equal height to panels with overhead storage cabinets on them.

When overhead storage units are suspended from stacking frames, the following guidelines should be adhered to:

- Stacking panels can be added to any base panel up to 80"H.
- Stacking frames should be added to all the parent run panels, and to each return-panel run. Stacking panels added to return panel must match the parent run configuration.
- A maximum of two overhead storage units should be suspended from each side of stacking frames on any given panel.

- No limitation to the number of units on structural frames when run is supported with return panels on each side of storage shelves or overhead storage cabinets.

- **Assembled metal overhead cabinets** can be mounted on a panel equal to or up to 18" narrower than cabinet using provided panel attachment brackets.
- One side of overhead must be held on-module.

- **RTA overhead, RTA shelf, and receding door** width must correspond with width of panel(s).
- It is possible to span two panels when combined panel width equals cabinet or shelf width.

Overheads, Shelves, and Hutches

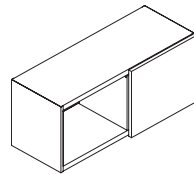

Sliding Door Overhead

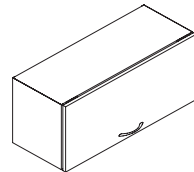

Flipper Door Overhead

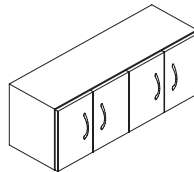

Hinged Door Overhead

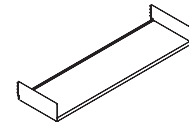

Open Shelf

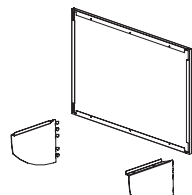

Upmount Kit for Overhead Cabinets

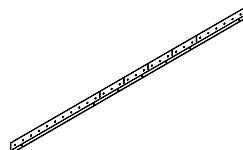

Horizontal Wall Track

Assembled Overhead Storage Cabinet (page 127)

- Steel cabinet with backstop.
- Available with sliding, hinged, or flipper door(s).
- Easy-Assist flipper door optional — requires minimal assistance in opening and closing.
- Easy-Assist flipper door not available on 60"W or 72"W cabinets — specify 2–30"W cabinets or 2–36"W cabinets.
- Self-engaging safety latch to secure cabinet to panel.
- Width can correspond with width of panel, or two panels joined with an in-line connector kit.
- Arch or square pull optional on flipper doors.
- 60"W and 72"W flipper door cabinets have two doors with two independent locks.
- 24"-36"W hinged door cabinets have 1 lock and 2 optional pulls, 42"-48"W have 2 locks and 4 optional pulls.
- Accommodates recessed task lighting (specified separately).
- For locking specifications, see pages 302-304.
- Cabinets are 14¼"D x 15"H.
- 15"H cabinets can also be mounted on a panel equal to or up to 18" narrower than cabinet using provided panel attachment brackets.
- Sliding doors have a built-in pull.
- Sliding, Hinged, and Flipper Door Overhead Weight Limits:

24"W	59 lbs.	42"W	105 lbs.
30"W	74 lbs.	48"W	121 lbs.
36"W	90 lbs.	60"W	152 lbs.
- Mounting an overhead on frames that have an overall height of 57½"H is not recommended. Slot modularity in relation to adjacent panels may be compromised.

Assembled Open Shelf (page 127)

- Metal shelf with back stop.
- Locking clips (2) standard.
- Will accommodate recessed task lighting (ordered separately).
- Weight Limits:

24"W	61 lbs.	42"W	108 lbs.
30"W	77 lbs.	48"W	124 lbs.
36"W	93 lbs.	60"W	155 lbs.
- Mounting an open shelf on Optimize frames cannot span base panel frame and stack-on frame — slot modularity is not maintained.

Upmount Kits for Assembled Overhead Cabinets (page 127)

- Consists of two upmount brackets, full back panel, and required installation hardware.
- Allows mounting of an assembled overhead cabinet up to 15" above height of panel.
- Specify "Z2" prefix model number upmount kits with 15"H, 35"H, 50"H, or 65"H Optimize panels; and "Z4" prefix model number upmount kits with 42½"H Optimize panels.
- Brackets require a clearance of 6½" below bottom of overhead cabinet.
- Width must correspond with width of panel frame or 2 panel frames joined directly in-line.
- Full back panel adds ½" to depth of overhead case.
- Full back panel only used when upmounting cabinet.
- Cannot be used with RTA models.

Horizontal Wall Track (page 127)

- Allows mounting assembled overhead cabinets on permanent wall structures ONLY. Attachment hardware not included.
- Cannot be used with RTA models.
- Track is 60"W and notched at 6" intervals as a guide for field cutting.
- For use with 15"H sliding door overhead, field modification is necessary.
- Available in black only.

OPTIMIZE

Overheads, Shelves, and Hutches

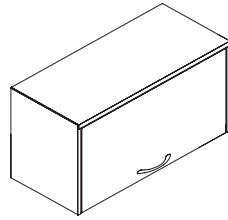

Assembled Receding Door Overhead Storage Cabinet (page 128)

- Steel cabinet with open back. Optional back can be ordered separately.
- Arch or square pull optional.
- 60"W cabinet has 2 – 30"W doors with 2 independent locks.
- Accommodates recessed task lighting — ordered separately.
- For locking specifications, see pages 302-304.
- Cabinets are 13¼"D x 15"H. When door is recessed, interior dimensions are 12⅝"D x 11⅝"H.
- Weight Limits:

30"W	70 lbs.	48"W	110 lbs.
36"W	85 lbs.	60"W	138 lbs.
42"W	100 lbs.		

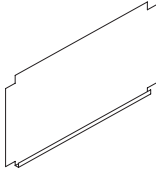

Receding Door Overhead Back (page 128)

- Optional for use with receding door overhead.
- Order width to match overhead cabinet.

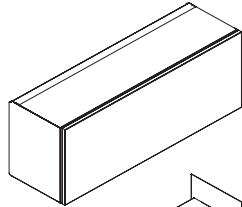

Ready to Assemble (RTA) Flipper Door Overhead (page 128)

- Steel cabinet with open back.
- 60"W and 72"W cabinets have 2 doors with independent locks.
- Accommodates recessed task lighting — ordered separately.
- Random keying, for locking specifications see pages 302-304.
- Cabinets are 12"D x 15"H. Interior dimensions 11⅝"D x 12¼"H.

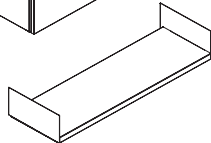

Ready to Assemble (RTA) Shelf (page 128)

- Metal shelf with locking clips.
- Accommodates recessed task lighting — ordered separately.

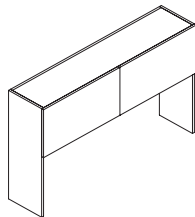

Stack-On Hutch

Stack-on Hutch (page 129)

- Have flipper doors with square horizontal edges.
- Universal model can be converted to an open hutch.
- Doors are standard with a core removable lock (60"W, 66"W and 72"W have two doors and two locks.)
- Attachment tape provided.
- Order hutch to match width of worksurface(s) it covers.
- Hutches have clearance of 19¼" for computers, etc.
- Depth dimensions shown includes thickness of door.
- Universal model inside depth dimension is 12¼".
- Stack-on hutches accommodate recessed task lighting.
- For locking specification see pages 302-304.
- Chicago task light cords cannot be routed through the hutch end panels, due to the large size of the fused plugs.

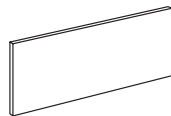

Tackboards for Hutches

Tackboards (page 129)

- Use tackboard to close the back of stack-on or hutch below storage unit.
- Due to width of fabric roll, 72"W tackboards are available in railroad cut only.

Metal Overheads

Optimize™ — Overheads / Shelves and Mounting Kits

For specification information see pages 123-126.

GSA SIN 33721

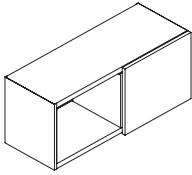
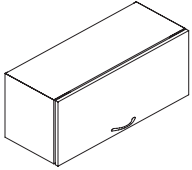
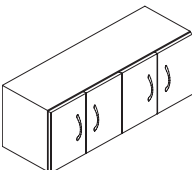
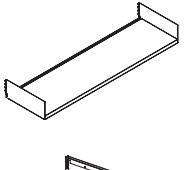
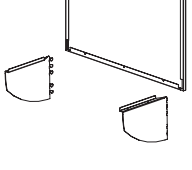
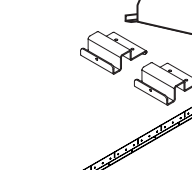
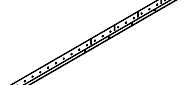
	Description	Model	P1 Paint List Price	P2 Paint List Price	P3 Paint List Price
	15"H x 14 1/4"D Sliding Single Door Overhead Cabinets				
	24"W	OH1524SD	\$ 1041	\$ 1120	\$ 1197
	30"W	OH1530SD	\$ 1064	\$ 1143	\$ 1220
	36"W	OH1536SD	\$ 1116	\$ 1195	\$ 1272
	42"W	OH1542SD	\$ 1166	\$ 1245	\$ 1322
	48"W	OH1548SD	\$ 1219	\$ 1298	\$ 1375
	60"W	OH1560SD	\$ 1609	\$ 1688	\$ 1765
	15"H x 14 1/4"D Flipper Door Overhead Cabinets				
	24"W	OH1524FD	\$ 1041	\$ 1120	\$ 1197
	30"W	OH1530FD	\$ 1064	\$ 1143	\$ 1220
	36"W	OH1536FD	\$ 1116	\$ 1195	\$ 1272
	42"W	OH1542FD	\$ 1166	\$ 1245	\$ 1322
	48"W	OH1548FD	\$ 1219	\$ 1298	\$ 1375
	60"W	OH1560FD	\$ 1609	\$ 1688	\$ 1765
	72"W	OH1572FD	\$ 2178	\$ 2257	\$ 2334
Note: Add suffix A for arch pull or S for square pull to model number — add \$43 per pull. For "Easy-Assist" on 24"W-48"W change FD suffix to FE – add \$240					
	15"H x 14 1/4"D Hinged Door Overhead Cabinets				
	24"W	OH1524HD	\$ 1781	\$ 1859	\$ 1936
	30"W	OH1530HD	\$ 1862	\$ 1940	\$ 2017
	36"W	OH1536HD	\$ 1949	\$ 2027	\$ 2104
	42"W	OH1542HD	\$ 2032	\$ 2110	\$ 2187
	48"W	OH1548HD	\$ 2107	\$ 2185	\$ 2262
Note: Add suffix A for arch pull or S for square pull to model number — add \$43 per pull.					
	4 7/8"H x 12 7/8"D Open Shelf (to line up with 15"H Overheads)				
	24"W	ZS24	\$ 444	\$ 472	\$ 497
	30"W	ZS30	\$ 482	\$ 510	\$ 535
	36"W	ZS36	\$ 508	\$ 536	\$ 561
	42"W	ZS42	\$ 532	\$ 560	\$ 585
	48"W	ZS48	\$ 558	\$ 586	\$ 611
	60"W	ZS60	\$ 679	\$ 707	\$ 732
	72"W	ZS72	\$ 997	\$ 1025	\$ 1050
	Upmount Kits for Overhead Cabinets — Specify "Z4" prefix models with 42 1/2"H panels; "Z2" for all other panel heights.				
	24"W	Z UP24	\$ 269	\$ 298	\$ 324
	30"W	Z UP30	\$ 282	\$ 311	\$ 337
	36"W	Z UP36	\$ 290	\$ 319	\$ 345
	42"W	Z UP42	\$ 305	\$ 334	\$ 360
	48"W	Z UP48	\$ 320	\$ 349	\$ 375
	60"W	Z UP60	\$ 342	\$ 371	\$ 397
	Shelf Dividers for Assembled Overhead Cabinets and Open Shelf				
	Package of 6	T7DV	\$ 144	\$ 162	\$ 173
Note: Not compatible with RTA models.					
	Horizontal Wall Track				
	60"W Track	TWTH	\$ 135	N/A	N/A

How to specify — Select the Model Number from above.	1st Option: Pull (if applicable): A Arch pull, add \$43 per pull S Square pull, add \$43 per pull	2nd Option: System (if applicable): YZ Optimize or Concensys	3rd Option: Paint (if applicable): P1 P2 P3 See page 68 for finishes.	4th Option: Pull Color (if applicable): Arch: E4 Black EL Matte Silver Square: EL Matte Silver	5th Option: Lock Type (if applicable): STD Standard — Random Keyed OMT Omit Lock Core (Deduct \$20 per lock)
	_____ . Y Z . P _____ . E _____ .				

Examples: OH1536FEA.YZ.P01.E4.STD OH1548FDS.YZ.P52.EL.OMT

[S] Shippable by small-package carrier.

Metal Overheads

For specification information see pages 123-126.

GSA SIN 33721

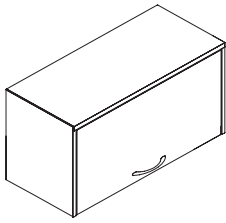

Description	Model	P1 Paint List Price	P2 Paint List Price	P3 Paint List Price
15"H x 13 1/2"D Assembled Receding Door Overheads (inside dimensions with door recessed — 11 1/8"H x 12 1/8"D)				
30"W	OH1530RD	\$ 1221	\$ 1300	\$ 1377
36"W	OH1536RD	\$ 1288	\$ 1367	\$ 1444
42"W	OH1542RD	\$ 1368	\$ 1447	\$ 1524
48"W	OH1548RD	\$ 1483	\$ 1562	\$ 1639
60"W	OH1560RD	\$ 2243	\$ 2322	\$ 2399

Note: Add Suffix **A** for arch pull or **S** for square pull option — add \$43 per pull.

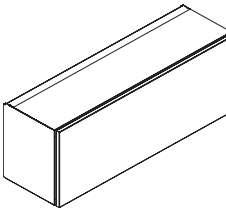

15"H x 12"D Ready to Assemble (RTA) Flipper Door Overhead (inside dimensions 12 3/4"H x 11 1/8"D)				
36"W RTA — Flipper Door	POHRTA1536FD	\$ 875	\$ 954	\$ 1031
42"W RTA — Flipper Door	POHRTA1542FD	\$ 914	\$ 993	\$ 1070
48"W RTA — Flipper Door	POHRTA1548FD	\$ 953	\$ 1032	\$ 1109

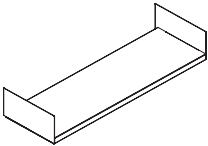

5 1/2"H x 12"D Ready to Assemble (RTA) Shelf				
36"W RTA — Shelf	POHRTA36S	\$ 456	\$ 483	\$ 506
48"W RTA — Shelf	POHRTA48S	\$ 501	\$ 528	\$ 551

OPTIMIZE

<p>How to specify — Select the Model Number from above.</p>	<p><i>1st Option:</i> Receding Door Pull (if applicable): A Arch Pull, add \$43 per pull S Square Pull, add \$43 per pull</p>	<p><i>2nd Option:</i> System for Assembled Receding Door Overhead (if applicable): YZ Optimize or Concensys</p>	<p><i>3rd Option:</i> Paint: P1 P2 P3 See page 68 for finishes.</p>	<p><i>4th Option:</i> Receding Door Pull Color (if applicable): Arch: E4 Black EL Silver Square: EL Silver</p>	<p><i>5th Option:</i> Receding Door Lock (if applicable): STD Standard OMT Omit Lock Core (Deduct \$20 per lock)</p>
<p>_____</p>	<p>_____ .</p>	<p>Y Z .</p>	<p>P _____</p>	<p>E _____ .</p>	<p>_____</p>

Examples: OH1560RD.YZ.P7C.STD OH1536RDA.YZ.P27.E4.OMT
POHRTA1536FD.P27

Metal Hutches

Optimize™ — Hutches, Tackboards, and Accessories

For specification information see pages [123-126](#).

GSA SIN 33721

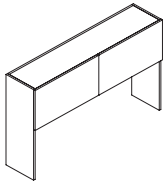

Description	Universal Model	P1 Paint List Price	P2 Paint List Price	P3 Paint List Price
Essentials Hutch w/Square Flipper Doors and Lock — 14½"D x 35"H				
36"W	UH6536FD □	\$ 1200	\$ 1282	\$ 1362
42"W	UH6542FD □	\$ 1255	\$ 1337	\$ 1417
48"W	UH6548FD □	\$ 1297	\$ 1379	\$ 1459
60"W	UH6560FD □	\$ 1838	\$ 1920	\$ 2000
66"W	UH6566FD □	\$ 1928	\$ 2010	\$ 2090
72"W	UH6572FD □	\$ 2020	\$ 2102	\$ 2182



Shelf Dividers				
Package of 6	T7DV [S]	\$ 144	\$ 162	\$ 173

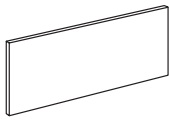

Description	Universal Model	P1 Paint List Price — Fabric			P2 Paint List Price — Fabric			P3 Paint List Price — Fabric		
		Grades A/B	Grades C/D	Grades E/F	Grades A/B	Grades C/D	Grades E/F	Grades A/B	Grades C/D	Grades E/F
20"H Tackboards for Stack-on Hutches										
36"W Tackboard	UHTB36 [S]	\$ 540	\$ 637	\$ 798	\$ 567	\$ 664	\$ 825	\$ 590	\$ 687	\$ 848
42"W Tackboard	UHTB42 [S]	\$ 567	\$ 669	\$ 837	\$ 594	\$ 696	\$ 864	\$ 617	\$ 719	\$ 887
48"W Tackboard	UHTB48 [S]	\$ 618	\$ 734	\$ 924	\$ 645	\$ 761	\$ 951	\$ 668	\$ 784	\$ 974
60"W Tackboard	UHTB60 [S]	\$ 692	\$ 837	\$ 1077	\$ 719	\$ 864	\$ 1104	\$ 742	\$ 887	\$ 1127
66"W Tackboard	UHTB66 [S]	\$ 728	\$ 886	\$ 1149	\$ 755	\$ 913	\$ 1176	\$ 778	\$ 936	\$ 1199
72"W Tackboard	UHTB72 [S]	\$ 767	\$ 924	\$ 1184	\$ 794	\$ 951	\$ 1211	\$ 817	\$ 974	\$ 1234

How to specify —
Select the Model Number from above.

1st Option:
Pull
(if applicable):
Add \$43 per pull.
A Arch Pull
S Square Pull
N No Pull

2nd Option:
Paint:
[P1] [P2] [P3]
See page 68 for finishes.

3rd Option:
Fabric
(if applicable):
Limited fabric offering available — see page 10 for details.

3rd Option:
Lock Type
(if applicable):
STD Standard — Random Keyed
OMT Omit Lock Core (Deduct \$20 per lock)

4th Option:
Railroad Cut
(Tackboard only):
(Only applicable to 66" and 72"W Fabric Tackboards.)

_____ . **P** _____ .

_____ .

_____ .

R _____ **R** _____

Examples: UH6536FDN.P27.STD UHTB66.P52.APN934.RR

[S] Shippable by small-package carrier.

Notes

OPTIMIZE

Gallery Panels

Finishes	132
Panel Fabrics	133
Laminate and Paint Matching.....	134
Gallery Panels	135
Basic Characteristics.....	136
Dimensions	137
Working with Integrated Glass.....	138-139
Optimize - End Panel	140-141
Optimize - Mid Panel.....	142
Gallery-to-Gallery Panels	143
Freestanding Screens	144-145
Storage and Worksurface Connectors	146
Working with Accessories	147-149
Gallery Panels HAT Brackets	150
Gallery-to-Gallery Panels: 30"H Application.....	151
Gallery-to-Gallery Panels: 35"H Application.....	152
Gallery-to-Gallery Panels: 42"H Application.....	153
Gallery-to-Gallery Panels: 50"H Application.....	154
Gallery-to-Gallery Panels: 57½"H Application	155
Gallery-to-Gallery Panels: 30"H Application for use with Glass.....	156
Gallery-to-Gallery Panels: 35"H Application for use with Glass	157
Gallery-to-Gallery Panels: 42"H Application for use with Glass	158
Gallery-to-Gallery Panels: 50"H Application for use with Glass	159
Gallery-to-Gallery Panels: 57½"H Application for use with Glass.....	160
30"H Application	161
35"H Application	162
42"H Application	163
50"H Application	164
57½"H Application	165
30"H Application for Use with Glass	166
35"H Application for Use with Glass	167
42"H Application for Use with Glass	168
50"H Application for Use with Glass	169
57½"H Application for Use with Glass	170
Optimize Connector Kits	171
Panel Systems Gallery Glass.....	172-174
Accessories	175-177

PAINT FINISHES

GRADE P1

Black	P71
Brownstone	P7D
Bungalow	P7C
Charblack	CBK
Cinder	P7Q
Cove	P096
Designer White	PJW
Dune	P094
Flint	P02
Fossil	P28
Harbor	P097
Loft	P7B
Muslin	P4J
Parchment	P93
Pebble	P8R
Pewter	P8D
Salt	P8C
Sage	P095
Textured Brownstone	P7J
Textured Designer White	PK7
Textured Flint	P7A
Textured Loft	P7L
Textured Muslin	P7M
Textured Pebble	P8Y
Textured Salt	P8Z
Textured Titanium	P8V
Titanium	P8T

GRADE P2

Champagne Metallic	PR5
Gunmetal Metallic	PR3
Matte Gold	PG8
Night Bronze	P8B
Platinum Metallic	PR2
Pyrite	PJE
Silver	PR6
Silver Texture	PR8
Solar Black	P8X

Metallic paints, due to varying reflectance, may appear to have less visual color consistency than other paint finishes, even when L/A/B values are exactly the same. (L/A/B — measurable aspects of color — values are maintained within a specified range, to ensure consistent appearance of paint colors.)

GRADE P3

Atom	P8S
Blossom***	P8K
Bullseye	PJF
Ember	P8P
Ion	P8N
Iris	P8J
Krypton	P8F
Ochre	P093
Regatta	P8M
Sienna	P092
Succulent***	P8A

***These colors are intended to be an inspirational option for the trending market. Product application is limited and color availability is approximately two years to coincide with evolving workplace trends.

LAMINATES

GRADE L1

SOLID COLOR	
Black	P
Brownstone	LM13
Bungalow	LM12
Designer White	LDW1
Flint	LM16
Fossil Shale	LEH1
Loft	LM11
Muslin	LM15
Titanium	LTI1
ABSTRACT	
Handspun Pearl	LAHP
Handspun Dove	LAHD
Handspun Slate	LAHS
Handspun Chestnut	LAHC

WOODGRAIN

Belair	LWBA
Bourbon Cherry	H
Field Elm	LWFE
Florence Walnut	LFW1
Kingswood Walnut	LK11
Natural Maple	LWD
NeoWalnut	LNU1
Pinnacle	PINC
Shaker Cherry	LW7C

GRADE L2

Beigewood	LWBE
Fawn Cypress	LFC1
Lowell Ash	LLA1
Mangalore Mango	LMM1
Natural Recon	LNR1
Phantom Charcoal	LPC1
Phantom Ecru	LPE1
Portico Teak	LPT1
Skyline Walnut	LSW1
Veranda Teak	LVT1

GRADE L3

Natural Walnut	LWNW
----------------------	------

LAMINATE EDGE COLORS

Beigewood	DE
Belair	BA
Black	E4
Bourbon Cherry	H
Brownstone	EY
Bungalow	EX
Designer White	DW
Fawn Cypress	FC
Field Elm	FE
Flint	E9
Florence Walnut	FW
Fossil	EH
Kingswood Walnut	KI
Loft	EV
Lowell Ash	DL
Mangalore Mango	MM
Muslin	EU
Natural Maple	DD
Natural Recon	NR
Natural Walnut	DN
NeoWalnut	NU
Parchment	EN
Phantom Charcoal	PC
Phantom Ecru	PE
Pinnacle	PI
Plyband	PL
Portico Teak	DP
Shaker Cherry	DF
Skyline Walnut	SW
Titanium	TI
Veranda Teak	VT

Forest Stewardship Council (FSC) is a non-profit organization devoted to encouraging the responsible management of the world's forests. FSC sets high standards that ensure forestry is practiced in an environmentally responsible, socially beneficial, and economically viable way. Allsteel received its FSC Chain of Custody certification in 2010 and can offer FSC Certified products. Select wood-based products can be ordered as FSC certified, either by choosing the FSC option or selecting an FSC laminate or veneer finish at the time of order. For more information, please contact Customer Support at 888-255-7833. (FSC Trademark license code: FSC-CO14704.)

NOTE: Refer to individual product pages for upcharges.

GRADE A

APPOINT PANEL

100% Polyester

ArtichokeAPN911
BlackberryAPN932
BronzeAPN922
CarbonAPN928
ChaiAPN912
CherryAPN930
Dark PewterAPN917
DuneAPN915
EspressoAPN923
FramboiseAPN931
FrostAPN934
JetAPN927
LawnAPN925
MandarinAPN929
MorelAPN909
NimbusAPN916
PlatinumAPN924
TurquoiseAPN926

BINARY †

BlushBNRY12
CoalBNRY06
CreamBNRY01
DenimBNRY08
DiamondBNRY03
GraphiteBNRY05
JuniperBNRY10
LagoonBNRY07
LavendarBNRY11
MineralBNRY04
ReefBNRY09
Sand DollarBNRY02

CENTURION^W

(*Nanotex™ Stain-Resistant finish*)

ApricotCU47
BarkCU25
BlackCU10
EspressoCU49
FogCU03
FrostCU22
GoldenrodCU27
IndigoCU06
IrisCU50
Iron OreCU19
JadeCU83
MarsalaCU63
MorelCU24
NavyCU98
PeacockCU97
PearCU84
RubyCU67
SapphireCU09

CIRCUIT † ♣

AtlasCIRC35
DolphinCIRC63
Island WhiteCIRC14
MoonCIRC07
NightCIRC49
PacificCIRC28
QuartzCIRC01
SiennaCIRC56
SilkCIRC21
Snap PeaCIRC42

ETCH

100% Polyester

AxisECH913
BlendECH914
CastECH912
HighlightECH910
MidtoneECH911
OutlineECH908
ShadeECH909
TonalECH916
VanishECH915

GRADE A – continued

EXCHANGE

100% Polyester

IronEXG916
NickelEXG914
PistachioEXG910
RootEXG913
RupeeEXG903
ShadowEXG911
SilverEXG915
SisalEXG917
StoneEXG912

LANDSCAPE

100% Polyester

Corn silkLN15
DriftLN05
KhakiLN20
SheenLN10
SlateLN35
UmberLN25
UrbanLN30

LUCY

100% Recycled Polyester

AspenLC932
Corn silkLC930
DuskLC922
FawnLC933
GraphiteLC934
MistLC920
NeutraLC924
PewterLC935
SnowdropLC928

NOBLE

AegeanNBLE18
AmethystNBLE19
AspenNBLE14
AsterNBLE20
BlossomNBLE21
BluebellNBLE22
BordeauxNBLE01
BrickNBLE02
ChambrayNBLE10
ChamomileNBLE23
ClementineNBLE04
ConiferNBLE24
CottageNBLE25
DarknessNBLE26
DawnNBLE13
DenimNBLE09
Desert SandNBLE27
DewfallNBLE28
Dusted SageNBLE29
FlaxNBLE30
GrassNBLE07
GunmetalNBLE15
HarmonyNBLE31
HarvestNBLE12
Ice CavesNBLE32
IcicleNBLE33
InkyNBLE34
IrisNBLE35
JadeNBLE06
KnightNBLE17
MesaNBLE03
MonarchNBLE36
PacificNBLE08
PitchNBLE37
Queen BeeNBLE38
RainforestNBLE05
RegalNBLE11
SandcastleNBLE39
SedonaNBLE40
StormyNBLE16
SunbeamNBLE41
VoyagerNBLE42
Windy DayNBLE43

GRADE A – continued

REFLECTIONS

100% Recycled Polyester

GalvanizedREF929
IceREF920
LoggiaREF921
MistralREF928
MoonstoneREF923
PewterREF922
StainlessREF924
VanillaREF925
WinterREF927

REFUGE

*64% Recycled Polyester
36% Polyester*

ArtesianRFG996
DuneRFG992
EclipseRFG990
Frost †RFG993
Glacier †RFG976
MineralRFG998
TidalRFG994

SARTO ▼

100% Polyester (45% Recycled)

AshSRT988
FogSRT914
LemongrassSRT949
MistSRT945
MushroomSRT976
OysterSRT918
ReefSRT964
SesameSRT993
ShaleSRT952

TEMPEST

100% Recycled Polyester

DragonflyTP930
FrostTP915
Full StreamTP980
Gold RushTP910
SlateTP945
TumbleweedTP970
Wind ChillTP940
ZebraTP935

VAST

VineyardVST01
GardenVST02
GrasslandsVST03
BayVST04
Open AirVST05
AtmosphereVST06
OceanVST07
Mountain RangeVST08
HighwayVST09
TundraVST10
BeachVST11
DesertVST12
Country SideVST13

GRADE B

COAST † ♣

100% Antimony-Free Polyester

ChannelCOA914
DuneCOA903
HeadlandsCOA910
MarshCOA902
PebbleCOA912
PierCOA913
ShoalCOA901
SiltCOA906
TideCOA908

GRADE B – continued

DISPERSE †*

100% Polyester

AutumnDISP03
BranchDISP10
Coffee BeanDISP13
DuskDISP09
Emerald CityDISP08
Gold RushDISP02
IglooDISP11
InkDISP06
MistDISP12
OatmealDISP15
PrinceDISP07
ReservoirDISP01
RoseDISP04
SpringDISP05
SteelDISP16
TaupeDISP14

MICA (De-emphasized)

100% Recycled Polyester

AnthraciteMCA911
BreezeMCA918
BronzeMCA913
BuffMCA914
CreminiMCA917
Crystal †MCAWIT
DewMCA920
DoveMCA912
FreshMCA916
MineralMCA915
NectarMCA919
ShaleMCA910

SPIN PANEL

*46% Recycled Polyester,
56% Polyester*

AlabasterSPIN02
CavernSPIN03
CobblestoneSPIN04
EmberSPIN06
FlameSPIN07
HeronSPIN13
OatSPIN01
OceanSPIN12
PlumSPIN15
PoolSPIN11
RavenSPIN10
RhubarbSPIN14
TropicSPIN08
WillowSPIN05

TERRAIN

*52% Recycled Polyester,
48% Polyester*

BayTRRN05
BayouTRRN35
CanyonTRRN30
CliffTRRN45
CrestTRRN25
DeltaTRRN10
PlateauTRRN15
RidgeTRRN20
ValleyTRRN40

ALLSTEEL PARTNERSHIP PROGRAM

Allsteel understands that customers may want to specify panel and seating textiles outside of Allsteel's standard offering. Allsteel's **Partnership Program** consists of on-trend and design-forward patterns that have been tested and approved by Allsteel for use on Allsteel products. A subset of these approved patterns is available on cards in the textile binder, while numerous others are available on our website, allsteeloffice.com.

For memo samples, please contact our partners:

- Camira, memos@camirafabrics.com
1.616.288.0655
- CF Stinson, cfstinson.com
1.800.841.6279
- HBF Textiles, hbf textiles.com
1.877.494.5727
- Maharam, maharam.com
1.800.645.3943
- Ultrafabrics, ultrafabricsllc.com

The intent of the **Partnership Program** is to offer a wide variety of on-trend textiles to meet your varied needs, but since these textiles are not part of our standard offering they may be subject to extended lead times. Because new materials will be introduced regularly, Allsteel reserves the right to change the offering at any time.

PARTNERSHIP – GRADE D

Camira BLAZER LITE † ▼

(*100% Pure New Wool*)

AngelPCAMBLT49
AspirePCAMBLT52
BalancePCAMBLT41
BlissPCAMBLT48
BuddhaPCAMBLT56
CuddlePCAMBLT62
DaintyPCAMBLT64
DaydreamPCAMBLT46
DevotedPCAMBLT58
FaithPCAMBLT68
FreedomPCAMBLT69
GracefulPCAMBLT51
HappyPCAMBLT55
HarmonyPCAMBLT63
HavenPCAMBLT40
HopePCAMBLT50
HushPCAMBLT42
LovePCAMBLT47
MoodPCAMBLT44
PamperPCAMBLT66
PastelPCAMBLT65
PillowPCAMBLT43
PraisePCAMBLT54
RetreatPCAMBLT39
ShelterPCAMBLT60
SolacePCAMBLT70
TenderPCAMBLT53
TruePCAMBLT61
VerityPCAMBLT57
WishPCAMBLT67
WorshipPCAMBLT59

^W Limited to product 48"W or less.

▼ Panel fabric is not available on Further.

♣ Panel fabric is not available on Optimize®.

† Panel fabric is not available on Concensys®.

◆ Panel fabric is not available on Involve.

* Not available on 72"W.

Multi-use fabrics are seating fabrics that can be used on specific Allsteel panels systems, providing more color and pattern options. The applicable Allsteel multi-use fabrics are noted with System designators in the Seating, Collaboration, and Tables Price List.

Paint Recommendations for Gallery-to-Gallery Cover

Laminate	Code	Recommended Paint
Brownstone	LM13	Brownstone
Bungalow	LM12	Bungalow
Designer White 15051	LDW1	Designer White
Flint	LM16	Flint
Fossil Shale	LEH1	Fossil
Loft	LM11	Loft
Muslin	LM15	Muslin
Titanium	LT11	Titanium
Florence Walnut	LFW1	Cinder, Brownstone, Flint
Kingswood Walnut	LK11	Fossil, Flint, Loft
Natural Maple	LWD	Muslin
NeoWalnut	LNU1	Cinder
Shaker Cherry	LW7C	Black, Cinder
Beigewood	LWBE	Muslin, Loft, Fossil
Fawn Cypress	LFC1	Cinder, Brownstone, Flint
Lowell Ash	LLA1	Cinder
Mangalore Mango	LMM1	Cinder
Natural Recon	LNR1	Cinder, Brownstone
Phantom Charcoal	LPC1	Flint, Salt, Cinder
Phantom Ecrú	LPE1	Flint, Brownstone, Muslin
Portico Teak	LPT1	Fossil, Brownstone, Pewter
Skyline Walnut	LSW1	Cinder, Flint, Fossil
Veranda Teak	LVT1	Fossil, Brownstone, Pewter
Natural Walnut	LWNW	Cinder

Gallery Panels are ideal for bringing natural wood elements to workstations and providing privacy. Allsteel Gallery Panels are designed to work universally across 5 product platforms. Please follow the product guidelines for proper specification.

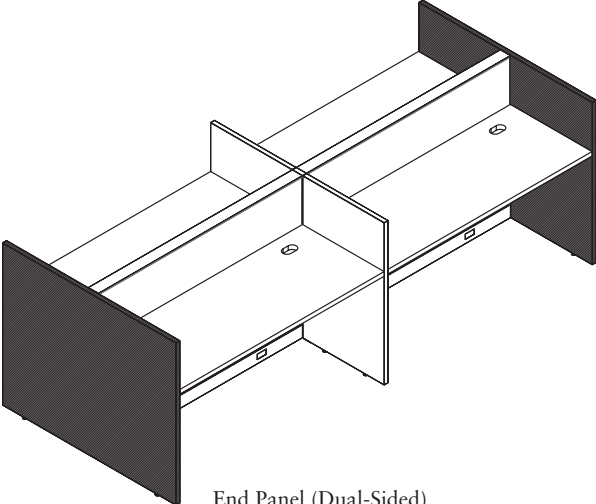

End Panel (Dual-Sided)

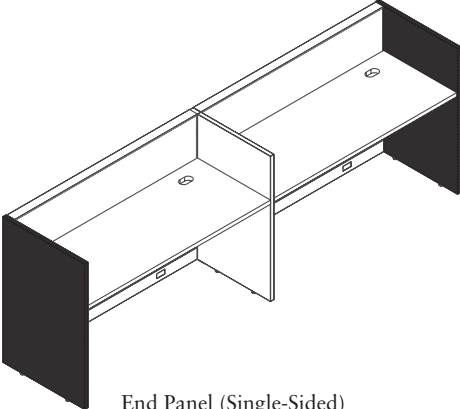

End Panel (Single-Sided)

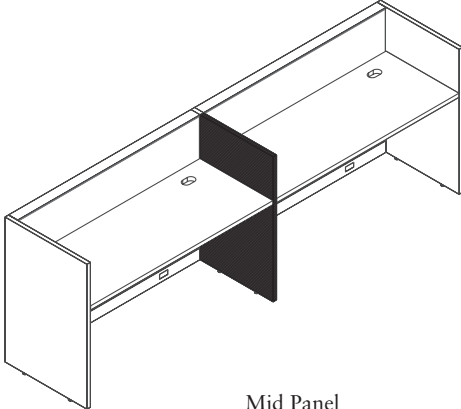

Mid Panel

- Available to connect to Frame & Tile, Monolithic, Benching systems, and other Gallery Panels
- Standard Gallery Panels connect to Benching, Frame & Tile, and Monolithic systems, and Gallery-to-Gallery panels connect to other Gallery Panels
- Gallery Panels can be used in freestanding applications. See page 144 for specification requirements.

Standard Gallery Panels

- Standard Gallery panels connect to Benching, Frame & Tile, and Monolithic systems and are available as End-of-Run Single and Mid Panels (panel systems only)
- Made of 1½" board with HPL laminate.
- Can be specified with matching or contrasting edge.
- Edge band is 2mm ABS
- Available in woodgrain and solid laminates.
- Woodgrain laminates can be specified with vertical grain up to 60"W. Horizontal grain is available on all sizes.
- Single Panel widths are available in 3" increments from 18"W to 84"W.
- Standard Gallery Panel sizes up to 84"W come as a single piece.
- Gallery Panels offer 2½" leveling capability.
- Overall heights line up with adjacent panel or benching systems.
- Standard Gallery panel widths are true to size
- Available with and without the integrated glass option.
- Glass is specified separately.
- Gallery Panels for use with glass have separate model numbers.
- All configurations are non-handed.
- Please adhere to all standard systems specification guidelines.
- Additional support is required after every 60" in gallery panel width (i.e. storage or worksurface tie-in)

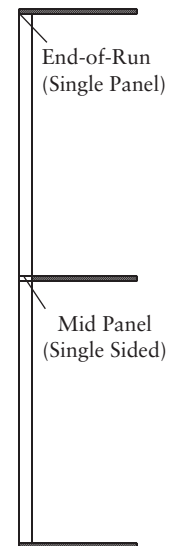
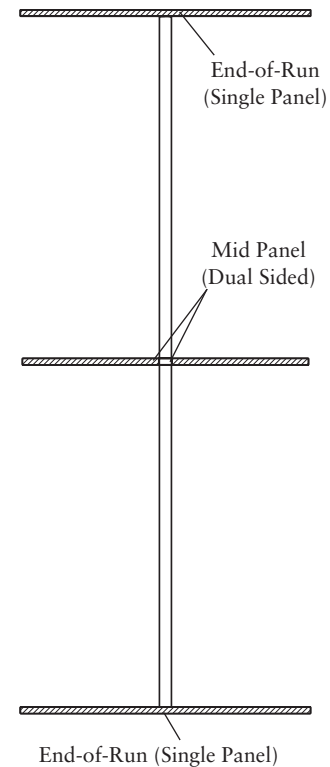

Standard Gallery Panel Widths

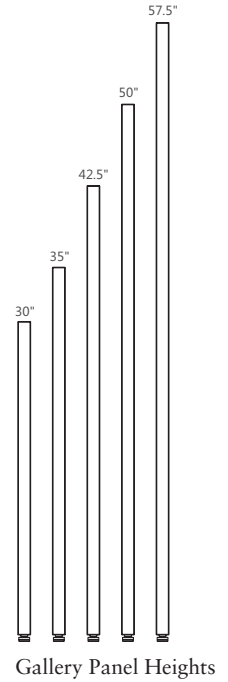
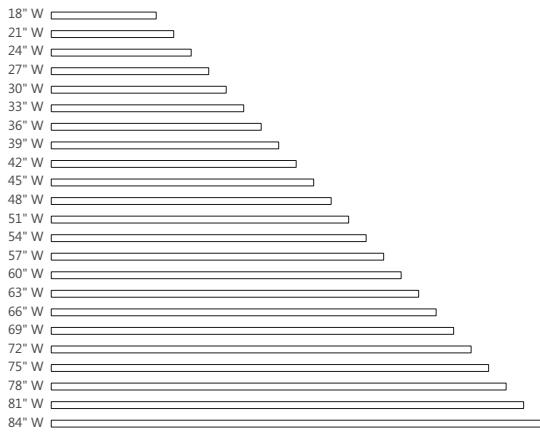

Gallery-to-Gallery Panel L/T Widths

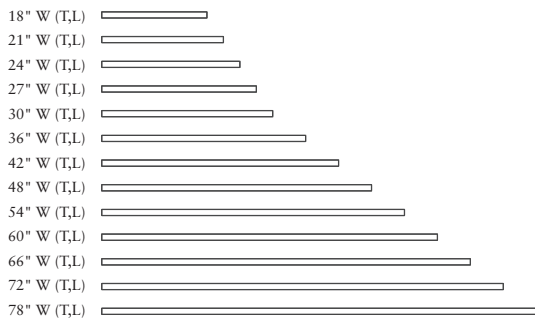

Standard Gallery Panels

- Gallery Panels for use with glass offer a routed top edge.
- Glass mounts directly into the Gallery Panel route via a gasket.
- The routing is inset 1½" from each end of the panel.
- Single-piece Gallery Panels for use with integrated glass require glass 3" shorter than the panel width.
- Glass is available in 3 colors: Clear, Frosted, Smoked.
- Glass height is available in 7½"H, 13"H, and 15"H.
- Glass is available on all Gallery Panel widths.
- Specify glass models separate from Gallery Panel models.
- Glass Panels at 30"W and under are not UL listed.

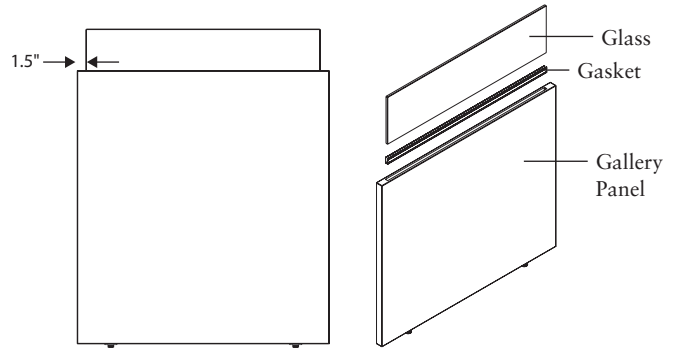

Standard Single Panel with Glass

Find the Gallery Glass width appropriate for your Gallery Panel width.

Shaded example:
For the 18"W
Gallery Panel,
Gallery Glass
should be ordered
with width of 15".

Gallery Panel Width	Gallery Glass Height	7.5"H, 13"H, 15"H
	Gallery Glass Order Width	
18"W Gallery Panel		15"W
21"W Gallery Panel		18"W
24"W Gallery Panel		21"W
27"W Gallery Panel		24"W
30"W Gallery Panel		27"W
33"W Gallery Panel		30"W
36"W Gallery Panel		33"W
39"W Gallery Panel		36"W
42"W Gallery Panel		39"W
45"W Gallery Panel		42"W
48"W Gallery Panel		45"W
51"W Gallery Panel		48"W
54"W Gallery Panel		51"W
57"W Gallery Panel		54"W
60"W Gallery Panel		57"W
63"W Gallery Panel		60"W
66"W Gallery Panel		63"W
69"W Gallery Panel		66"W
72"W Gallery Panel		69"W
75"W Gallery Panel		72"W
78"W Gallery Panel		75"W
81"W Gallery Panel		78"W
84"W Gallery Panel		81"W

Gallery-to-Gallery Panels

- Gallery Panels for use with glass offer a routed top edge.
- Glass mounts directly into the Gallery Panel route via a gasket.
- The routing is inset $\frac{1}{2}$ " from each end of the panel.
- Gallery-to-Gallery Panels for use with integrated glass require glass equal to the panel width.
- Glass is available in 3 colors: Clear, Frosted, Smoked.
- Glass height is available in 7½"H, 13"H, and 15"H
- Glass is available on all Gallery Panel widths. Glass panels at 30"W and under are not UL listed.
- Specify glass models separate from Gallery Panel models

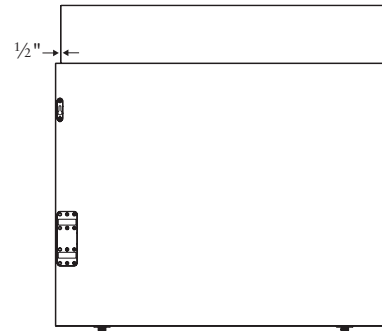

Gallery-to-Gallery Panel with Glass

Find the Gallery Glass width appropriate for your Gallery Panel width.

Gallery Panel Width	Gallery Glass Height	7.5"H, 13"H, 15"H
	Gallery Glass Order Width	
18"W Gallery Panel		18"W
21"W Gallery Panel		21"W
24"W Gallery Panel		24"W
27"W Gallery Panel		27"W
30"W Gallery Panel		30"W
36"W Gallery Panel		36"W
42"W Gallery Panel		42"W
48"W Gallery Panel		48"W
54"W Gallery Panel		54"W
60"W Gallery Panel		60"W
66"W Gallery Panel		66"W
72"W Gallery Panel		72"W
78"W Gallery Panel		78"W

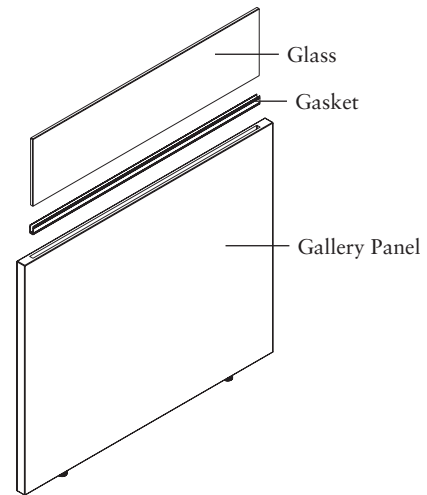

Gallery Panels

Optimize™ System - End Panel (Dual-Sided)

GSA SIN 33721

- Provides privacy to one or both ends of the system in a dual sided application.
- Single piece End Panels can be used for off-modular planning. Connector kit location must be field measured.
- End Gallery Panels cannot be shorter than spine panel.
- Optimize Gallery End Panels without integrated glass connect using P3CONGE connector kit.
- Optimize Gallery End Panels with integrated glass that match the height of the spine panel connect using P3CONGEG connector kit. (P3CONGEG only for use with dual-sided end panels with glass.)
- Must follow Optimize panel stability rules.

Front edge of Gallery Panel will sit ½" proud of front edge of worksurface on Optimize.

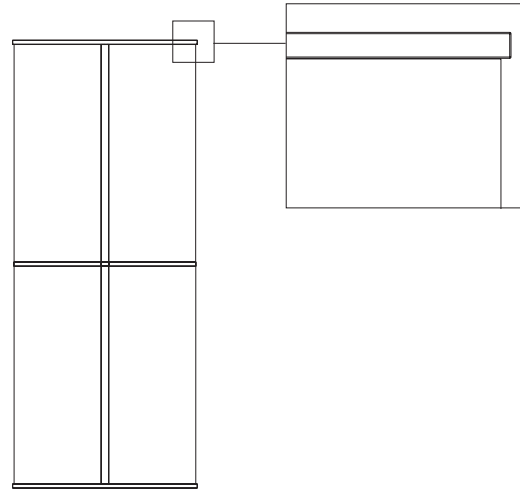

Detail of P3CONGE

Invisible connection on standard panels

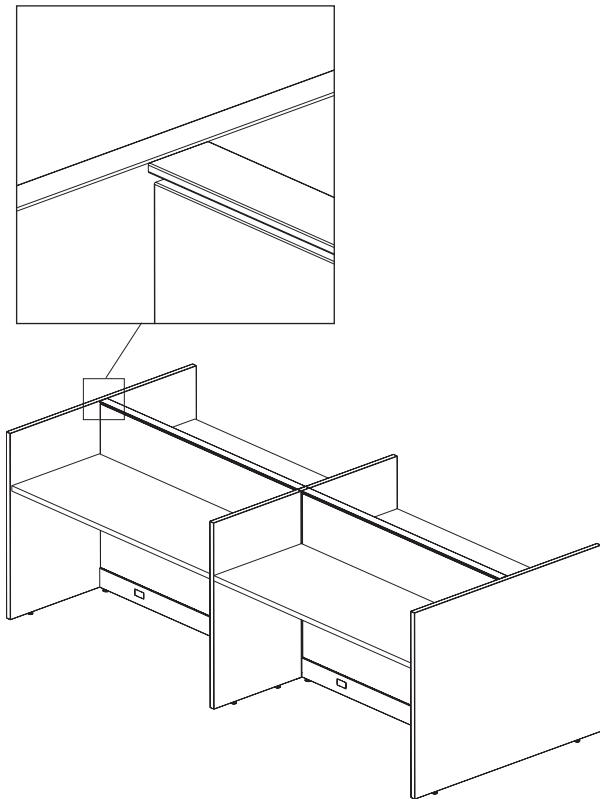

Detail of P3CONGEG

Visual of end connector on panels with integrated glass

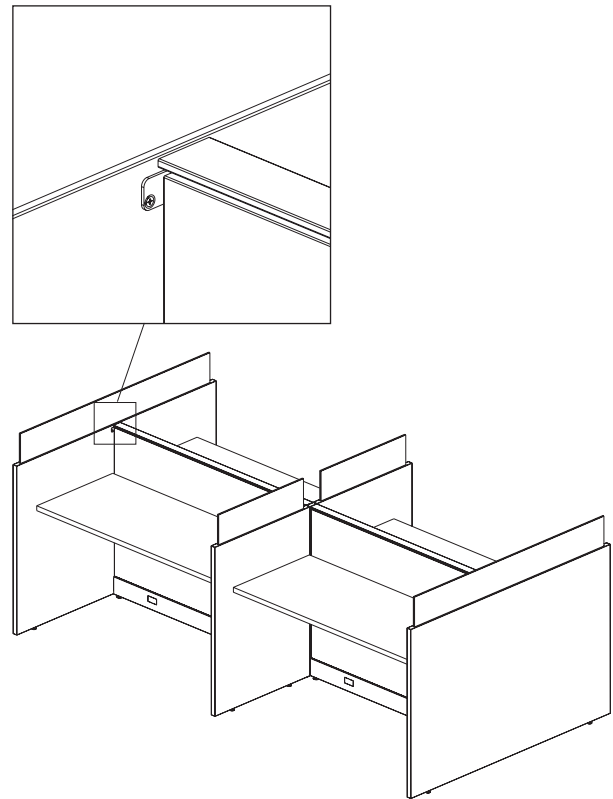

GSA SIN 33721

- Provides privacy to one or both ends of the system in a single sided application.
- Single-Sided End Panels cap over the System panel. Accommodate for 2 1/8" frame thickness when planning with Optimize panel system.
- All Optimize End Panels (Single-Sided) require connector kit P3CONGE to attach to parent run.
- Gallery Panel sizes 63"W or greater require storage or worksurface tie-in. Please reference storage and worksurface support sections for more details.
- Due to thickness of the Optimize panel Single-Sided End Panel overhangs by approximately 7/8" in front of a worksurface.
- End Gallery Panels cannot be shorter than spine panel.
- Optimize Gallery Single-Sided End Panels both with and without integrated glass connect using P3CONGE connector kit.
- When using stackers on the spine, use stacker bracket provided with connector kit OR fixed worksurfaces with cantilevers must be tied to the Gallery Panels. (See detail 1 below.)

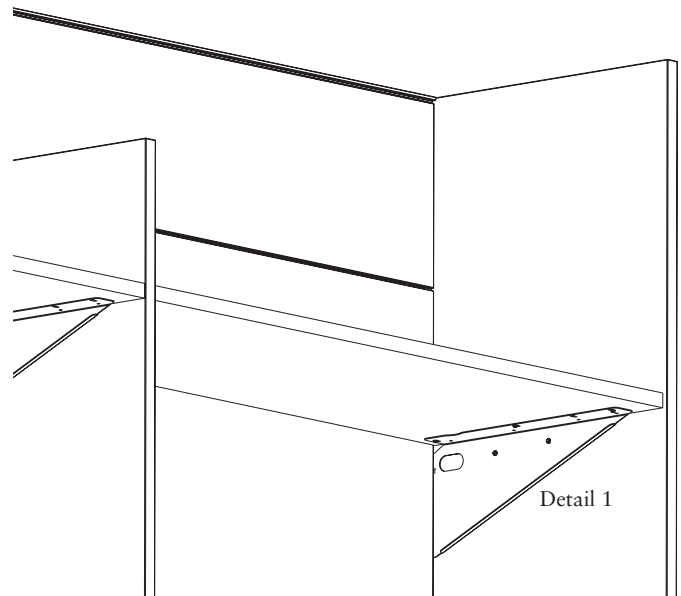
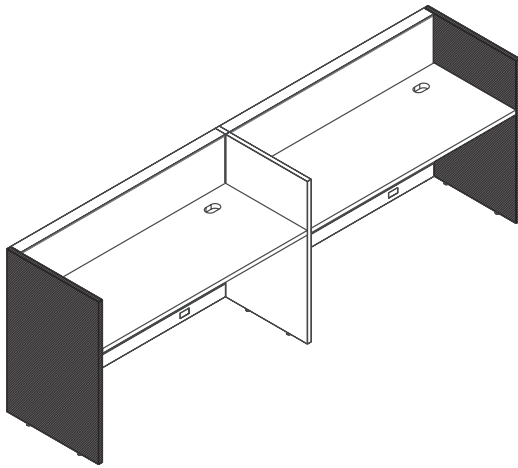
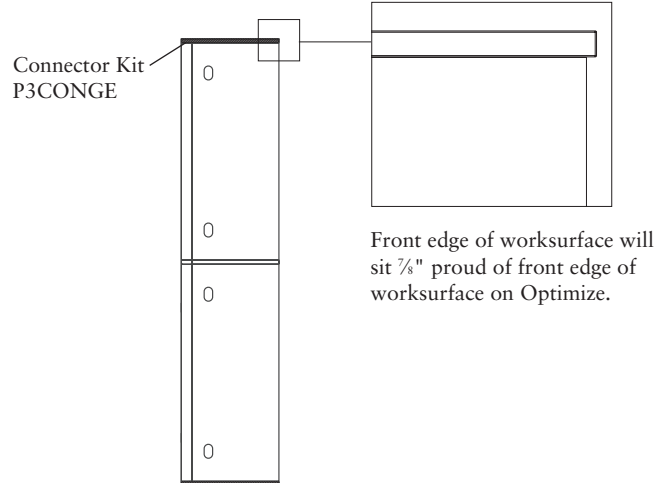

- Mid panels do not overlap parent system panel.
- When specifying single-sided Mid panels, one gallery panel single-sided mid connector kit is required to space the System panels out $1\frac{1}{8}$ ". Kits include: Connector post, connector strap, bracketry and a top cap.
- When specifying dual-sided Mid panels, one gallery panel dual-sided mid connector kit is required to space the System panels out $1\frac{1}{8}$ ". Kits include: Connector post, connector strap, bracketry and a top cap.
- Connector models must match the height of the parent run.
- Specify one mid-connector kit per "t" or "x" connection.
- When using a Mid panel, both panel frames in spine must be of equal height.
- Mid Panels may not vary in height of parent run by more than 15".
- Trims can be painted to match the System panel trims.
- Mid Panels are available in 18"-84" widths in 3" increments.
- Gallery Panel sizes 63"W or greater require storage or worksurface tie-in. Please reference storage and worksurface support sections for more details.
- Spanning top cap available through Allsteel Tailored Solution Group.

Mid panel must be 3" shorter than end panel due to panel frame thickness

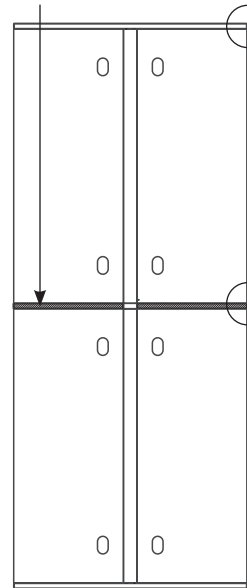

Dual-sided

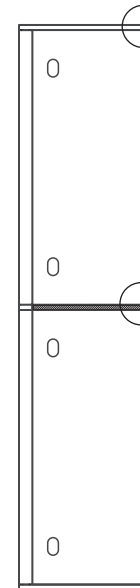

Single-sided

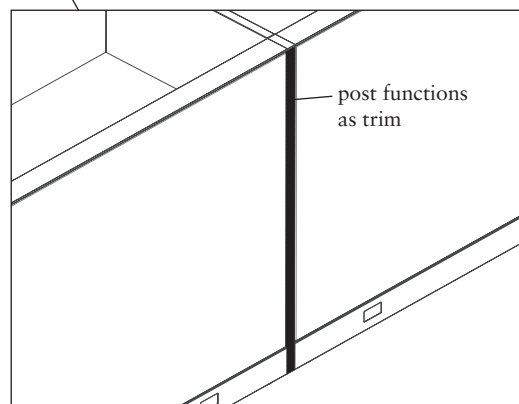
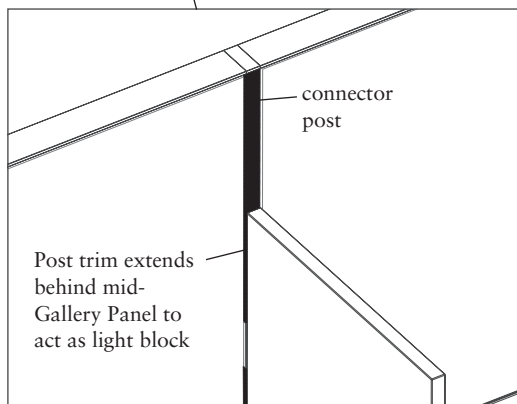
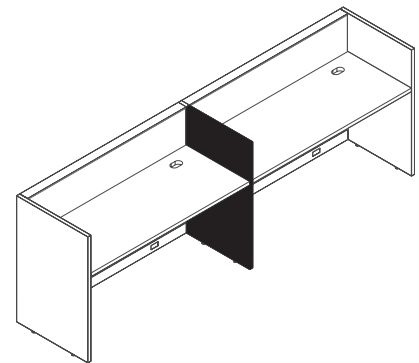
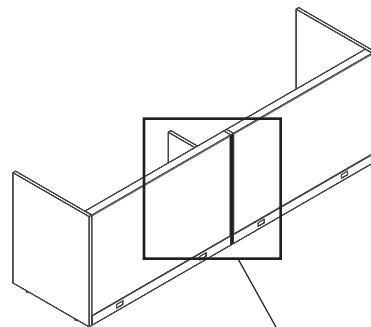
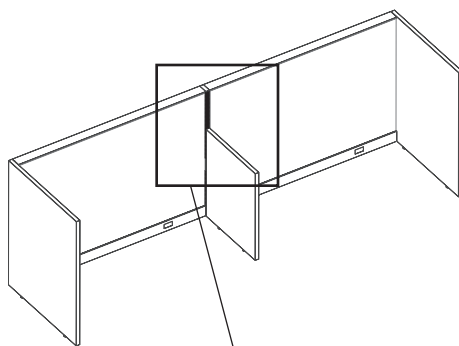

Gallery-to-Gallery Panels

- Gallery-to-Gallery panels connect to other gallery panels and are available in L-, T-, and Nonsymmetrical T- configurations.
- When specifying Gallery-to-Gallery panels, the installation template (GTEMP) is required. The recommendation is 1 template for every 30 panels. Templates are reusable.
- Gallery-to-Gallery panels cap over Standard Gallery panels and are oversized by 1/8" to maintain true interior dimensions
- Gallery-to-Gallery panels must be of equal or lower height than the Standard Gallery panel attached. The Gallery-to-Gallery panel cannot be taller than the adjacent panel. If this is required, please reach out to TPG for a custom solution.
- Made of 1/8" board with HPL laminate.
- Can be specified with matching or contrasting edge.
- Edge band is 2mm ABS
- Available in woodgrain and solid laminates.
- Woodgrain laminates can be specified with vertical grain up to 54"W. Horizontal grain is available on all sizes.
- Gallery-to-Gallery panel widths are available in 3" increments from 18"W to 30"W and in 6" increments from 30"W to 78"W
- Gallery Panels offer 2 1/2" leveling capability.
- Overall heights line up with adjacent panel or benching systems.
- Available with and without the integrated glass option.
- Glass is specified separately.
- Gallery Panels for use with glass have separate model numbers.
- Gallery-to-Gallery panels are secured with an inset flat bracket under a painted metal cover.
- L- and Nonsymmetrical T- panels are handed.
- Please adhere to all standard systems specification guidelines.
- Additional support is required after every 60" in gallery panel width (i.e. storage or worksurface tie-in)
- Nonsymmetrical T Panels are specified in the format GTyyxxzz. Substitute yy as panel height, xx as LH nominal length, and zz as RH nominal length

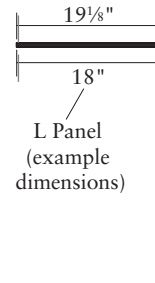

Note: Gallery-to-Gallery Panels cap over standard Gallery Panels and are oversized by 1/8" to maintain modular interior dimensions. (ex: 18" panel is actually 19 1/8"W)

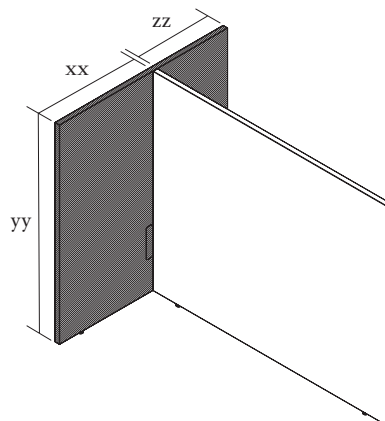
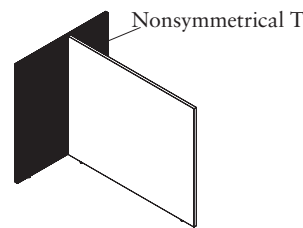
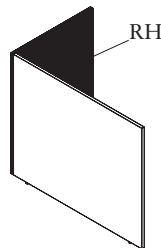
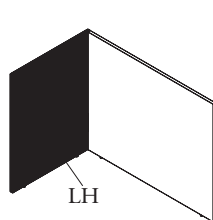
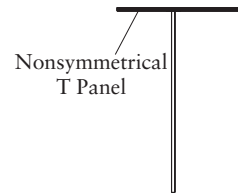
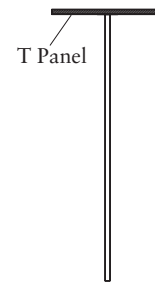

Freestanding Screens can be specified using Standard Gallery panels and Gallery-to-Gallery (depicted by the shaded panels in the illustrations below). Overall height, including glass, cannot exceed 72.5". Gallery Panel sizes 63"W or greater require storage or worksurface tie-in.

Freestanding L-Screens

Parent	Minimum Return
18-24	Not Valid
30-36	30
39-60	36
63-84	42

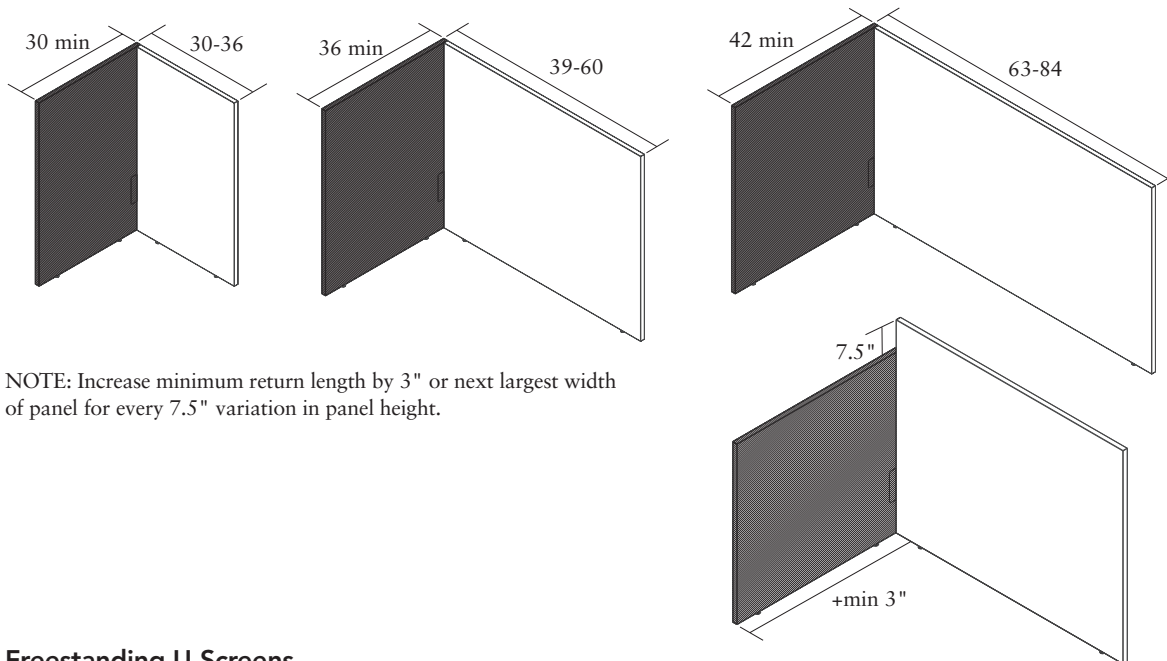

NOTE: Increase minimum return length by 3" or next largest width of panel for every 7.5" variation in panel height.

Freestanding U-Screens

Parent	Minimum Return
18-21	Not Valid
24-48	24
51-60	27
63-84	30

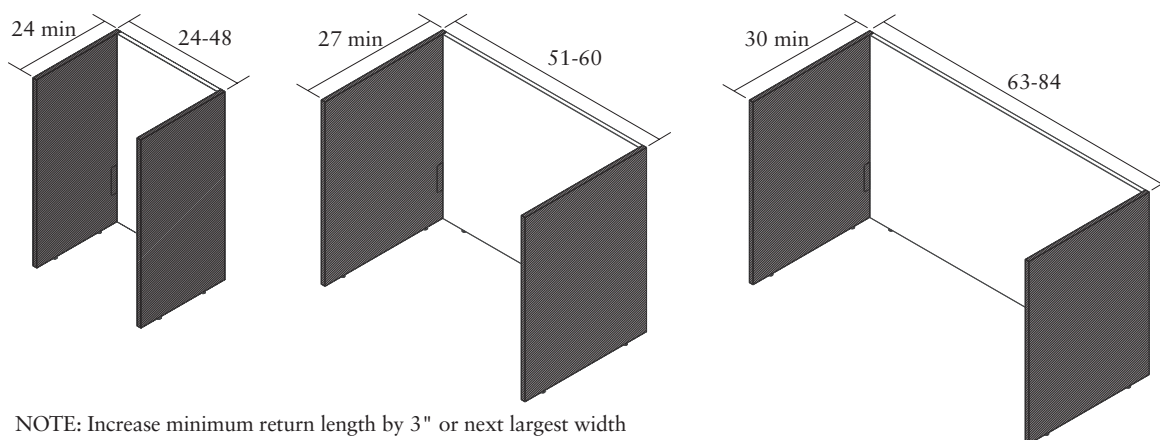

NOTE: Increase minimum return length by 3" or next largest width of panel for every 7.5" variation in panel height.

Freestanding T-Screens

T-Return	Minimum Parent
18-21	Not Valid
24-36	30-84
42-60	36-84
66-78	42-84

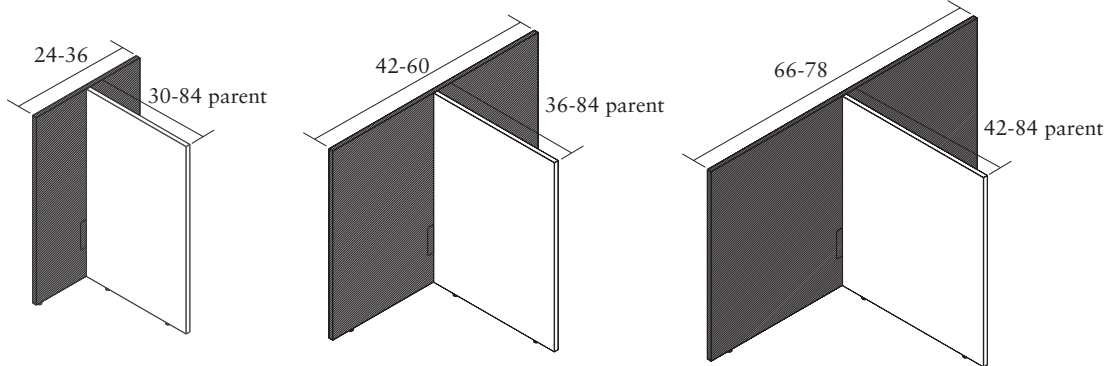

NOTE: Increase minimum return length by 3" or next largest width of panel for every 7.5" variation in panel height.

Freestanding H-Screens

Parent	Minimum H-Return
30-84	18

NOTE: Increase minimum return length by 3" or next largest width of panel for every 7.5" variation in panel height.

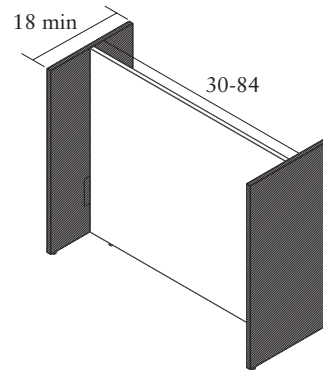

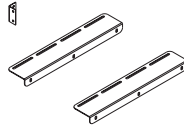

Worksurface Mounting Bracket (page 175)

- Used to mount a fixed-height worksurface to a Gallery panel.
- Can be painted any Allsteel Standard Paint color.
- A worksurface stiffener is required for surfaces 60" W or greater.
- One bracket kit (GWSBK) is required for each worksurface end attached to Gallery Panels.
- One bracket kit (GWSBK) includes two large L- brackets and one small corner L- bracket.

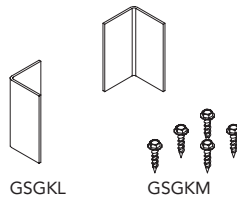
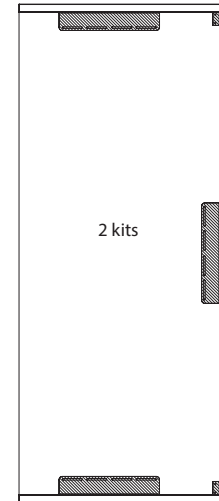
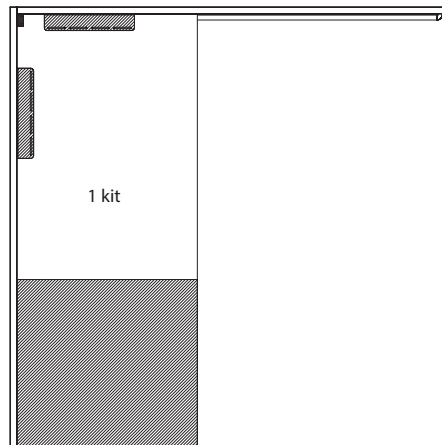
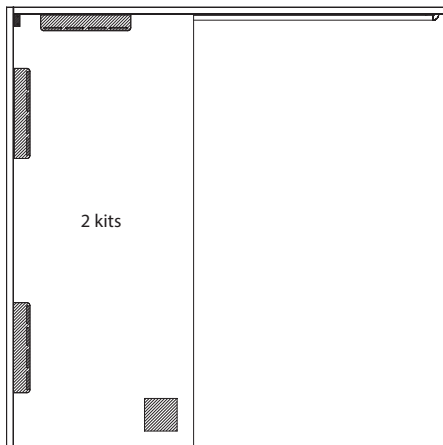

Storage Ganging Kits (page 171)

- The laminate storage ganging kit (GSGKL) is used to connect a Gallery Panel to a laminate storage unit.
- The metal storage ganging kit (GSGKM) is used to connect a Gallery Panel to a metal storage unit.

Gallery Panel Stiffeners (page 171)

- Required for single-piece panels 75" W and greater that are used in a wing or single-sided end condition and do not have a horizontally-mounted credenza.
- For panels 75" W and 78" W, order model (GSTFN7578). Stiffener width is 72".
- For panels 81" W and 84" W, order model (GSTFN8184). Stiffener width is 78".
- Attaches directly to one side of the Gallery Panel with a painted metal cover, attachment hardware included.
- Placement on panel face must be at least 18" above the floor but is not restricted to a specific location on the panel.
- Stiffener is 1½" x 1½".
- Available in any Allsteel standard paint color

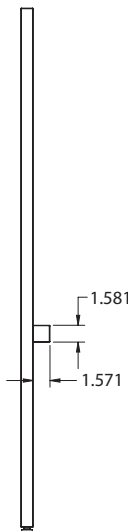

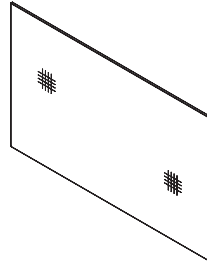

Tackboards (page 176)

- Provides tackable surface.
- Comes with steel-painted trim.
- Available in the following heights: 15", 22½"
- Available in the following *widths: 24", 30", 36", 42", 48", 54", 60".
*Nominal widths, true width is undersized by ½"
- Depth of .45"
- Mounts directly to Gallery Panel. Mounting hardware included. Will deface the panel.

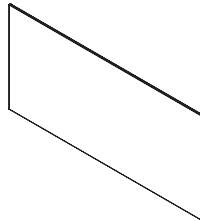

Magnet or Marker Boards (page 176)

- Provides writable and magnetic surface when painted in marker board paint.
- Provides magnetic surface, NON-writable, when painted in other Allsteel paint colors.
- Available in the following heights: 15", 22½"
- Available in the following *widths: 24", 30", 36", 42", 48", 54", 60".
*Nominal widths, true width is undersized by ½"
- Depth of .45"
- Mounts directly to Gallery Panel. Mounting hardware included. Will deface the panel.

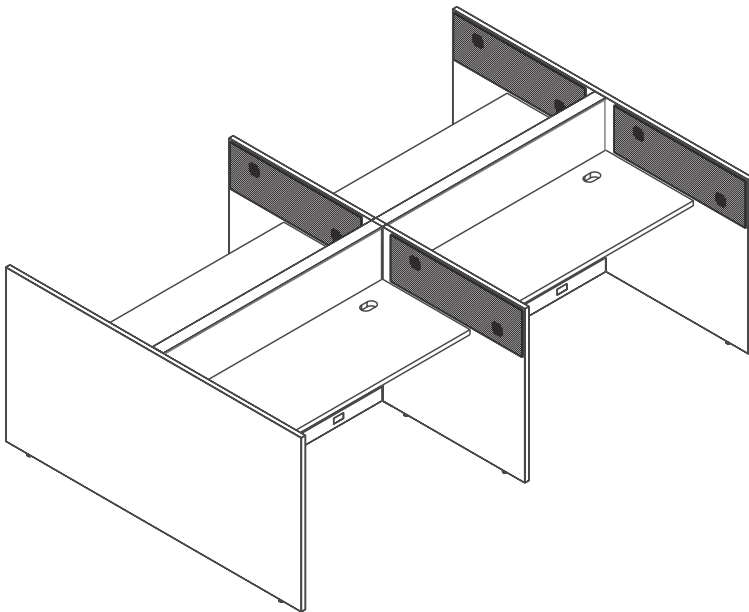

Tackboard Accessory on Mid and End Gallery Panels

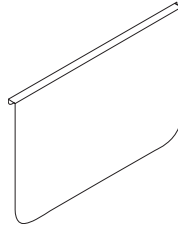

Hanging Magnet or Marker Boards (page 176)

- Hangs over Gallery panel or sits on top of worksurface.
- Provides writable and magnetic surface when painted in marker board paint.
- Provides magnetic surface, NON-writable, when painted in other Allsteel paint colors.
- Cannot be installed back-to-back when hanging in the same location.
- Available in 30" W and in two heights: 20" H and 26" H.

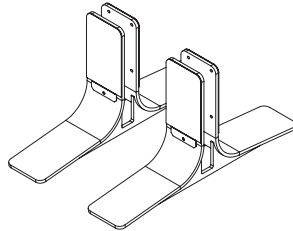

Gallery Panel Foot (page 176)

- Single foot provides rigidity to large wing panel.
- Using two feet on a single Gallery Panel allows for a freestanding application on panels greater than 24" W.
- Available in any textured Allsteel paint.
- Foot extends 9" from either side of the panel.

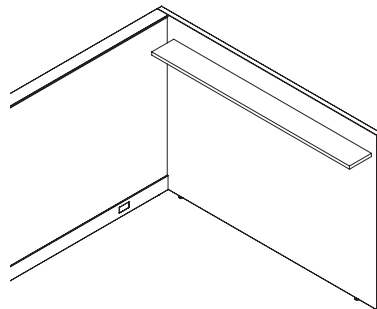
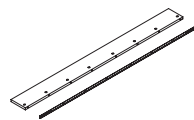
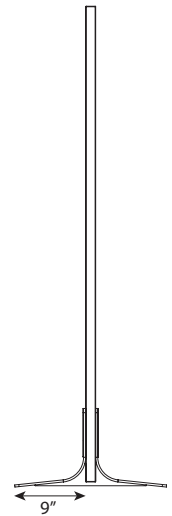
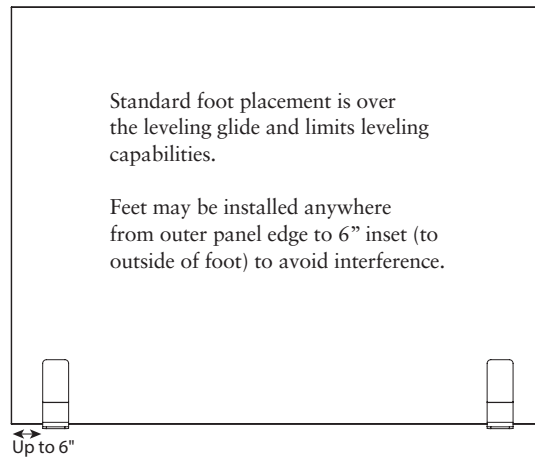
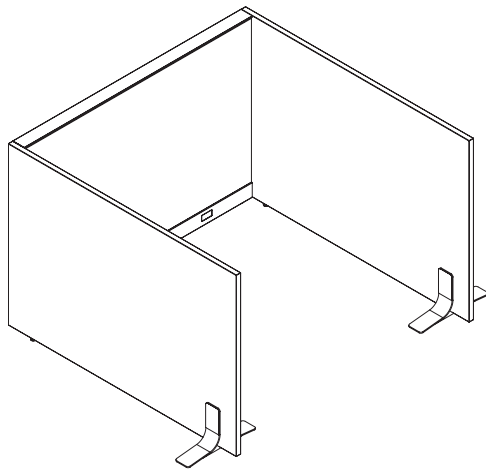

Floating Laminate Shelves (page 177)

- 6" depth.
- 3/4" thickness.
- Constructed of HPL laminate with 0.8mm ABS edgebanding.
- Available in solid or horizontal woodgrain laminate.
- Available with contrasting or matching edge.
- Widths available every 6" from 12" to 78" W.
- Widths from 54" to 78" satisfy a stiffener requirement and are meant to be mounted to a panel that is 6" wider than the shelf. (e.g., 84" W panel would accept a 78" W stiffener shelf.)
- Shelves narrower than 54" W do not act as a stiffener.
- Weight capacity is 10lbs per linear foot.



GACRL12

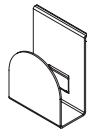

GCHRB

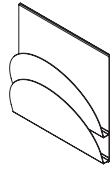

G2AGF

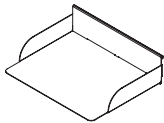

G1PTR

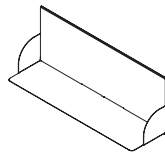

GWPSF

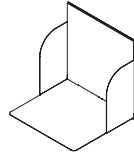

GBRSF

Accessory Rail and Paper Management (page 177)

- Accessory Rail provides mounting for paper management accessories, listed below.
- Rail is 2.6"H and is available in the following widths: 12", 18", 24", 30", 36".
- Rails can be installed in any location on the Gallery Panel, as long as the rail does not extend beyond the top of the panel, and can be placed in-line to span panel length.
- Rail and accessories can be painted any standard Allsteel paint color.
- Mounts directly to the Gallery panel, attachment hardware included.
- Extensions accessories are NOT compatible with the accessory rail.
- These accessories are compatible with panel system tool tiles and rails.
- Includes a rail cover to hide hardware and provide magnetic surface.
- Compatible Rail Accessories:
 - Coat Hook (Rail-based, a mounted version is also available to attach directly to the panel)
 - Rail Based dimensions: 4" x 3" x 1¼"
 - Mounted dimensions: 4" x 3" x 1½"
 - Weight limit: 25 lbs
 - Angle File (Triple, Dual, and Single heights)
 - Depth of 2"
 - Heights: Triple = 15½", Dual = 12½", Single = 9½"
 - Paper Tray (Triple, Dual, and Single heights)
 - Depth of 10"
 - Heights: Triple = 9½", Dual = 6½", Single = 3½"
 - Personal Shelf
 - 9½" x 24" x 10½"
 - Weight limit: 25 lbs
 - Binder Shelf
 - 12½" x 12" x 11½"
 - Weight limit: 25lbs

NOTE: When accessory tools are attached to freestanding Gallery Panel screens, excess weight may affect overall panel stability.



Wall Start (page 175)

- Wall Starts are 1⅝" by 1⅝" rectangular mounting posts that are meant to affix a Gallery Panel to a permanent building wall.
- Wall starts add 1⅝" to panel run.
- Attachment hardware not included.
- Must be specified at the same height as the connecting panel.

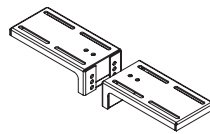

Countertop Brackets (page 175)

- Includes attachment hardware.
- Countertops are flush with the top of the panel and can be flush with the ends of the panel or shorter than the panel width.
- For straight countertops, two countertop brackets must be ordered.
- For corner countertops, three countertop brackets must be ordered.
- Will deface the Gallery Panel.
- May be used in conjunction with Stride, Terrace, or Optimize panels. When transitioning from a Panel spine to a Gallery Panel wing with a corner countertop, use countertop model of the panel system.

Height Adjustable Table Tie-In Brackets (Gallery Panels)

- Improves panel rigidity. Does not function as a panel stability solution.
- AGBKT to be specified for connection to a T leg HAT
- AGBKC to be specified for connection to a C leg HAT
- Reusable mounting template is required and must be ordered separately (AGBKTMP).
- Brackets telescope to account for 24" and 30" worksurface depths and screen attachments.
- A6 C legs with a 30"D worksurface and a screen must be specified with T leg brackets
- **Can be used with Altitude MAX bases when attaching to Gallery panels or Fit panels.**
- Height adjustable table brackets must be installed to both sides of the panel to substitute for a return panel in a dual-sided panel bench application. When a single bracket is connected to a wing panel as shown in the 4-pack image, the HAT bracket can substitute for a return panel.
- Freestanding panel can be connected to height adjustable table if it is supported by HAT brackets on both sides of the table and panel spine.

SINGLE BRACKET

Gallery Panel Application:

Max Height (with Glass): 65"H

Max Width: 75"W; No top size restrictions

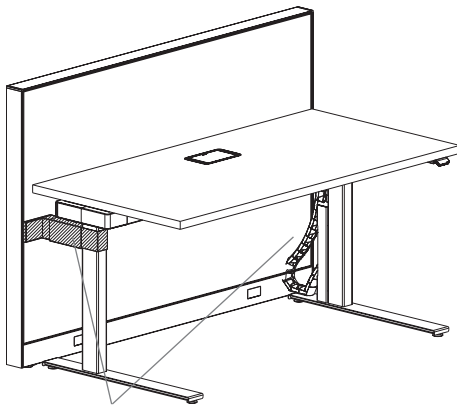
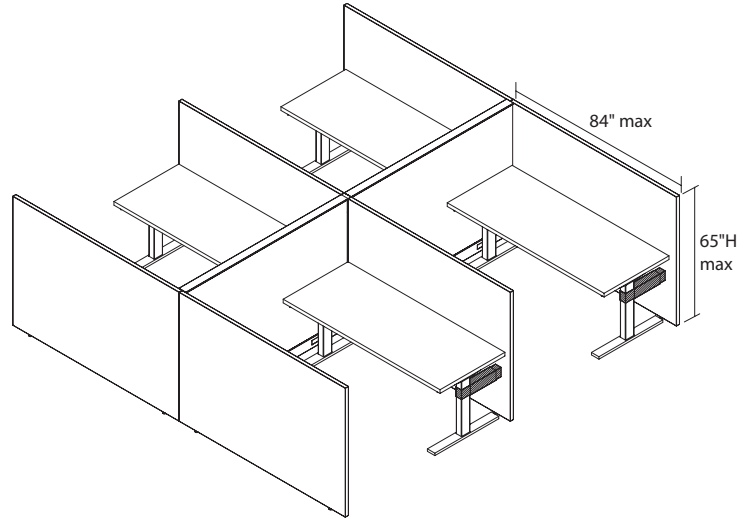

Note: Wire chain cannot be installed on the same leg as a HAT tie-in bracket.

DUAL SIDED PANEL BENCH

Gallery Panel Application:

Max Height (with Glass): 65"H

Bracket Needed: Single Panel (75" max) with Brackets on each leg (placed at the same height)

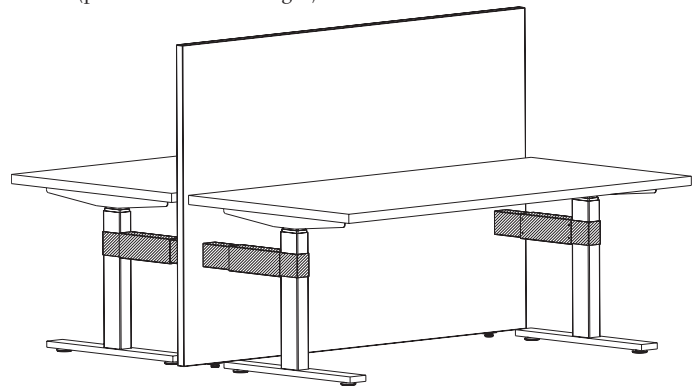

Freestanding Gallery Panel Application

Gallery Panels

Gallery-to-Gallery Panels: 30"H Application

GSA SIN 33721

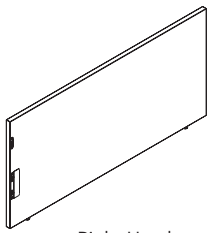

Right Hand

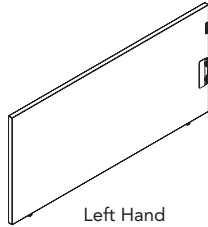

Left Hand

Description	Model	List Price				
		L1	L2	L3		
30"H L- Gallery-to-Gallery Panels						
18"W (RH)	GL3018R	\$ 719	\$ 746	\$ 772		
18"W (LH)	GL3018L	\$ 719	\$ 746	\$ 772		
21"W (RH)	GL3021R	\$ 734	\$ 761	\$ 788		
21"W (LH)	GL3021L	\$ 734	\$ 761	\$ 788		
24"W (RH)	GL3024R	\$ 767	\$ 795	\$ 823		
24"W (LH)	GL3024L	\$ 767	\$ 795	\$ 823		
27"W (RH)	GL3027R	\$ 805	\$ 835	\$ 863		
27"W (LH)	GL3027L	\$ 805	\$ 835	\$ 863		
30"W (RH)	GL3030R	\$ 887	\$ 919	\$ 952		
30"W (LH)	GL3030L	\$ 887	\$ 919	\$ 952		
36"W (RH)	GL3036R	\$ 960	\$ 996	\$ 1030		
36"W (LH)	GL3036L	\$ 960	\$ 996	\$ 1030		
42"W (RH)	GL3042R	\$ 1049	\$ 1089	\$ 1126		
42"W (LH)	GL3042L	\$ 1049	\$ 1089	\$ 1126		
48"W (RH)	GL3048R	\$ 1172	\$ 1215	\$ 1257		
48"W (LH)	GL3048L	\$ 1172	\$ 1215	\$ 1257		
54"W (RH)	GL3054R	\$ 1239	\$ 1284	\$ 1329		
54"W (LH)	GL3054L	\$ 1239	\$ 1284	\$ 1329		
60"W (RH)	GL3060R	\$ 1336	\$ 1385	\$ 1432		
60"W (LH)	GL3060L	\$ 1336	\$ 1385	\$ 1432		
66"W (RH)	GL3066R	\$ 1377	\$ 1427	\$ 1476		
66"W (LH)	GL3066L	\$ 1377	\$ 1427	\$ 1476		
72"W (RH)	GL3072R	\$ 1499	\$ 1554	\$ 1608		
72"W (LH)	GL3072L	\$ 1499	\$ 1554	\$ 1608		
78"W (RH)	GL3078R	\$ 1730	\$ 1792	\$ 1854		
78"W (LH)	GL3078L	\$ 1730	\$ 1792	\$ 1854		

30"H T- Gallery-to-Gallery Panels

18"W	GT3018	\$ 718	\$ 745	\$ 771
21"W	GT3021	\$ 735	\$ 762	\$ 789
24"W	GT3024	\$ 767	\$ 795	\$ 823
27"W	GT3027	\$ 805	\$ 835	\$ 863
30"W	GT3030	\$ 884	\$ 916	\$ 949
36"W	GT3036	\$ 958	\$ 994	\$ 1028
42"W	GT3042	\$ 1051	\$ 1091	\$ 1128
48"W	GT3048	\$ 1174	\$ 1217	\$ 1259
54"W	GT3054	\$ 1236	\$ 1281	\$ 1326
60"W	GT3060	\$ 1334	\$ 1383	\$ 1430
66"W	GT3066	\$ 1378	\$ 1428	\$ 1477
72"W	GT3072	\$ 1499	\$ 1554	\$ 1608
78"W	GT3078	\$ 1730	\$ 1792	\$ 1854

30"H Nonsym T- Gallery-to-Gallery Panels

42"W 18L 24R	GT301824	\$ 1051	\$ 1091	\$ 1128
42"W 24L 18R	GT302418	\$ 1051	\$ 1091	\$ 1128
48"W 18L 30R	GT301830	\$ 1072	\$ 1115	\$ 1157
48"W 30L 18R	GT303018	\$ 1072	\$ 1115	\$ 1157
54"W 24L 30R	GT302430	\$ 1236	\$ 1281	\$ 1326
54"W 30L 24R	GT303024	\$ 1236	\$ 1281	\$ 1326

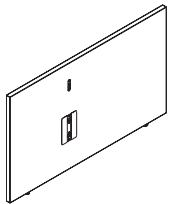

Description	Model	List Price
Gallery-to-Gallery Installation Template (<i>Black only, code P</i>)	GTEMP	\$ 79

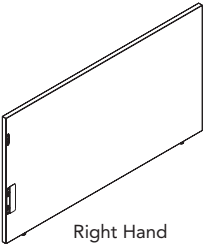
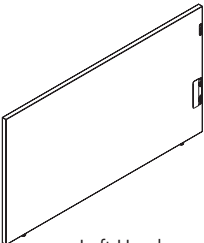

How to specify — Select the Model Number from above.	1st Option: FSC: (if applicable): F FSC Wood X Non-FSC Wood	2nd Option: Laminate: (if applicable): See page 132 for finishes.	3rd Option: Edge: See page 132 for finishes.	4th Option: Grain: (if applicable): VLG Horizontal grain or Solid only. VST Vertical Grain (available only for single panels 60"W or less, and for split panels between 87"W and 117"W).	5th Option: Paint See page 132 for finishes.	6th Option: Glide: (if applicable):
	G 	V .	.	G

	Description	Model	List Price		
			L1	L2	L3
 <p>Right Hand</p>  <p>Left Hand</p>	35"H L- Gallery-to-Gallery Panels				
	18"W (RH)	GL3518R	\$ 811	\$ 841	\$ 870
	18"W (LH)	GL3518L	\$ 811	\$ 841	\$ 870
	21"W (RH)	GL3521R	\$ 830	\$ 860	\$ 890
	21"W (LH)	GL3521L	\$ 830	\$ 860	\$ 890
	24"W (RH)	GL3524R	\$ 867	\$ 899	\$ 929
	24"W (LH)	GL3524L	\$ 867	\$ 899	\$ 929
	27"W (RH)	GL3527R	\$ 901	\$ 934	\$ 967
	27"W (LH)	GL3527L	\$ 901	\$ 934	\$ 967
	30"W (RH)	GL3530R	\$ 1005	\$ 1042	\$ 1078
	30"W (LH)	GL3530L	\$ 1005	\$ 1042	\$ 1078
	36"W (RH)	GL3536R	\$ 1094	\$ 1135	\$ 1174
	36"W (LH)	GL3536L	\$ 1094	\$ 1135	\$ 1174
	42"W (RH)	GL3542R	\$ 1164	\$ 1207	\$ 1248
	42"W (LH)	GL3542L	\$ 1164	\$ 1207	\$ 1248
	48"W (RH)	GL3548R	\$ 1265	\$ 1311	\$ 1357
	48"W (LH)	GL3548L	\$ 1265	\$ 1311	\$ 1357
	54"W (RH)	GL3554R	\$ 1341	\$ 1390	\$ 1438
	54"W (LH)	GL3554L	\$ 1341	\$ 1390	\$ 1438
	60"W (RH)	GL3560R	\$ 1426	\$ 1479	\$ 1529
60"W (LH)	GL3560L	\$ 1426	\$ 1479	\$ 1529	
66"W (RH)	GL3566R	\$ 1490	\$ 1545	\$ 1598	
66"W (LH)	GL3566L	\$ 1490	\$ 1545	\$ 1598	
72"W (RH)	GL3572R	\$ 1616	\$ 1675	\$ 1733	
72"W (LH)	GL3572L	\$ 1616	\$ 1675	\$ 1733	
78"W (RH)	GL3578R	\$ 1804	\$ 1870	\$ 1934	
78"W (LH)	GL3578L	\$ 1804	\$ 1870	\$ 1934	

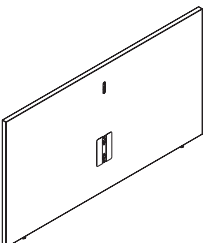
	35"H T- Gallery-to-Gallery Panels				
	18"W	GT3518	\$ 810	\$ 840	\$ 869
	21"W	GT3521	\$ 830	\$ 860	\$ 890
	24"W	GT3524	\$ 868	\$ 900	\$ 930
	27"W	GT3527	\$ 902	\$ 935	\$ 968
	30"W	GT3530	\$ 1005	\$ 1042	\$ 1078
	36"W	GT3536	\$ 1094	\$ 1135	\$ 1174
	42"W	GT3542	\$ 1163	\$ 1206	\$ 1247
	48"W	GT3548	\$ 1266	\$ 1312	\$ 1358
	54"W	GT3554	\$ 1342	\$ 1391	\$ 1439
	60"W	GT3560	\$ 1426	\$ 1479	\$ 1529
	66"W	GT3566	\$ 1490	\$ 1545	\$ 1598
	72"W	GT3572	\$ 1615	\$ 1674	\$ 1732
78"W	GT3578	\$ 1804	\$ 1870	\$ 1934	

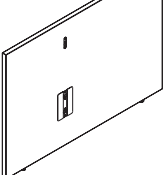
	35"H Nonsym T- Gallery-to-Gallery Panels				
	42"W 18L 24R	GT351824	\$ 1163	\$ 1206	\$ 1247
	42"W 24L 18R	GT352418	\$ 1163	\$ 1206	\$ 1247
	48"W 18L 30R	GT351830	\$ 1266	\$ 1312	\$ 1358
	48"W 30L 18R	GT353018	\$ 1266	\$ 1312	\$ 1358
	54"W 24L 30R	GT352430	\$ 1342	\$ 1391	\$ 1439
54"W 30L 24R	GT353024	\$ 1342	\$ 1391	\$ 1439	

Description	Model	List Price
Gallery-to-Gallery Installation Template (<i>Black only, code P</i>)	GTEMP	\$ 79

<p>How to specify — Select the Model Number from above.</p>	<p><i>1st Option:</i> FSC: (if applicable): F FSC Wood X Non-FSC Wood</p>	<p><i>2nd Option:</i> Laminate: (if applicable): See page 132 for finishes.</p>	<p><i>3rd Option:</i> Edge: See page 132 for finishes.</p>	<p><i>4th Option:</i> Grain: (if applicable): VLG Horizontal grain or Solid only. VST Vertical Grain (available only for single panels 60"W or less, and for split panels between 87"W and 117"W).</p>	<p><i>5th Option:</i> Paint See page 132 for finishes.</p>	<p><i>6th Option:</i> Glide: (if applicable):</p>
	<p>G . .</p>	<p> .</p>	<p> .</p>	<p>V .</p>	<p> .</p>	<p>G </p>

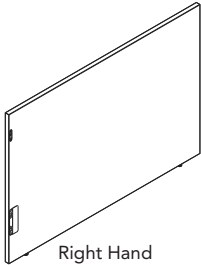
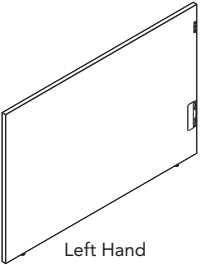
	Description	Model	List Price		
			L1	L2	L3
 Right Hand  Left Hand	42"H L- Gallery-to-Gallery Panels				
	18"W (RH)	GL4218R	\$ 880	\$ 912	\$ 944
	18"W (LH)	GL4218L	\$ 880	\$ 912	\$ 944
	21"W (RH)	GL4221R	\$ 895	\$ 928	\$ 960
	21"W (LH)	GL4221L	\$ 895	\$ 928	\$ 960
	24"W (RH)	GL4224R	\$ 941	\$ 975	\$ 1009
	24"W (LH)	GL4224L	\$ 941	\$ 975	\$ 1009
	27"W (RH)	GL4227R	\$ 983	\$ 1019	\$ 1055
	27"W (LH)	GL4227L	\$ 983	\$ 1019	\$ 1055
	30"W (RH)	GL4230R	\$ 1096	\$ 1137	\$ 1176
	30"W (LH)	GL4230L	\$ 1096	\$ 1137	\$ 1176
	36"W (RH)	GL4236R	\$ 1196	\$ 1240	\$ 1282
	36"W (LH)	GL4236L	\$ 1196	\$ 1240	\$ 1282
	42"W (RH)	GL4242R	\$ 1278	\$ 1325	\$ 1371
	42"W (LH)	GL4242L	\$ 1278	\$ 1325	\$ 1371
	48"W (RH)	GL4248R	\$ 1360	\$ 1409	\$ 1458
	48"W (LH)	GL4248L	\$ 1360	\$ 1409	\$ 1458
	54"W (RH)	GL4254R	\$ 1470	\$ 1524	\$ 1577
	54"W (LH)	GL4254L	\$ 1470	\$ 1524	\$ 1577
		60"W (RH)	GL4260R	\$ 1550	\$ 1606
	60"W (LH)	GL4260L	\$ 1550	\$ 1606	\$ 1662
	66"W (RH)	GL4266R	\$ 1631	\$ 1690	\$ 1749
	66"W (LH)	GL4266L	\$ 1631	\$ 1690	\$ 1749
	72"W (RH)	GL4272R	\$ 1744	\$ 1808	\$ 1869
	72"W (LH)	GL4272L	\$ 1744	\$ 1808	\$ 1869
	78"W (RH)	GL4278R	\$ 1899	\$ 1969	\$ 2035
	78"W (LH)	GL4278L	\$ 1899	\$ 1969	\$ 2035

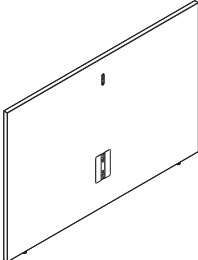
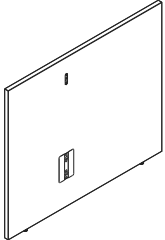
	Description	Model	List Price		
			L1	L2	L3
 	42"H T- Gallery-to-Gallery Panels				
	18"W	GT4218	\$ 881	\$ 913	\$ 945
	21"W	GT4221	\$ 896	\$ 929	\$ 961
	24"W	GT4224	\$ 943	\$ 977	\$ 1011
	27"W	GT4227	\$ 982	\$ 1018	\$ 1054
	30"W	GT4230	\$ 1099	\$ 1140	\$ 1179
	36"W	GT4236	\$ 1197	\$ 1241	\$ 1283
	42"W	GT4242	\$ 1279	\$ 1326	\$ 1372
	48"W	GT4248	\$ 1363	\$ 1412	\$ 1461
	54"W	GT4254	\$ 1472	\$ 1526	\$ 1579
	60"W	GT4260	\$ 1551	\$ 1607	\$ 1663
	66"W	GT4266	\$ 1632	\$ 1691	\$ 1750
	72"W	GT4272	\$ 1744	\$ 1808	\$ 1869
	78"W	GT4278	\$ 1900	\$ 1970	\$ 2036

	Description	Model	List Price		
			L1	L2	L3
	42"H Nonsym T- Gallery-to-Gallery Panels				
	42"W 18L 24R	GT421824	\$ 1279	\$ 1326	\$ 1372
	42"W 24L 18R	GT422418	\$ 1279	\$ 1326	\$ 1372
	48"W 18L 30R	GT421830	\$ 1363	\$ 1412	\$ 1461
	48"W 30L 18R	GT423018	\$ 1363	\$ 1412	\$ 1461
	54"W 24L 30R	GT422430	\$ 1472	\$ 1526	\$ 1579
	54"W 30L 24R	GT423024	\$ 1472	\$ 1526	\$ 1579

	Description	Model	List Price		
			L1	L2	L3
	Gallery-to-Gallery Installation Template (Black only, code P)				
		GTEMP		\$ 79	

How to specify — Select the Model Number from above. G	1st Option: FSC: (if applicable): F FSC Wood X Non-FSC Wood	2nd Option: Laminate: (if applicable): See page 132 for finishes.	3rd Option: Edge: See page 132 for finishes.	4th Option: Grain: (if applicable): VLG Horizontal grain or Solid only. VST Vertical Grain (available only for single panels 60"W or less, and for split panels between 87"W and 117"W).	5th Option: Paint See page 132 for finishes.	6th Option: Glide: (if applicable):

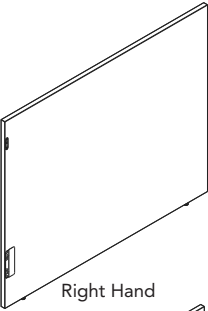
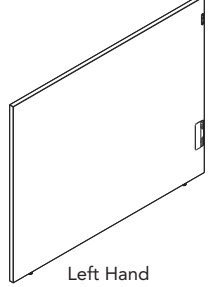
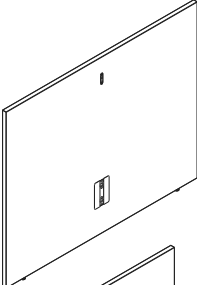
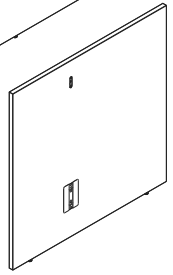
	Description	Model	List Price		
			L1	L2	L3
 <p>Right Hand</p>  <p>Left Hand</p>	50"H L- Gallery-to-Gallery Panels				
	18"W (RH)	GL5018R	\$ 989	\$ 1026	\$ 1061
	18"W (LH)	GL5018L	\$ 989	\$ 1026	\$ 1061
	21"W (RH)	GL5021R	\$ 1011	\$ 1048	\$ 1085
	21"W (LH)	GL5021L	\$ 1011	\$ 1048	\$ 1085
	24"W (RH)	GL5024R	\$ 1049	\$ 1089	\$ 1126
	24"W (LH)	GL5024L	\$ 1049	\$ 1089	\$ 1126
	27"W (RH)	GL5027R	\$ 1093	\$ 1134	\$ 1173
	27"W (LH)	GL5027L	\$ 1093	\$ 1134	\$ 1173
	30"W (RH)	GL5030R	\$ 1192	\$ 1236	\$ 1278
	30"W (LH)	GL5030L	\$ 1192	\$ 1236	\$ 1278
	36"W (RH)	GL5036R	\$ 1294	\$ 1341	\$ 1388
	36"W (LH)	GL5036L	\$ 1294	\$ 1341	\$ 1388
	42"W (RH)	GL5042R	\$ 1387	\$ 1437	\$ 1486
	42"W (LH)	GL5042L	\$ 1387	\$ 1437	\$ 1486
	48"W (RH)	GL5048R	\$ 1505	\$ 1560	\$ 1614
	48"W (LH)	GL5048L	\$ 1505	\$ 1560	\$ 1614
	54"W (RH)	GL5054R	\$ 1594	\$ 1652	\$ 1710
	54"W (LH)	GL5054L	\$ 1594	\$ 1652	\$ 1710
	60"W (RH)	GL5060R	\$ 1672	\$ 1732	\$ 1793
	60"W (LH)	GL5060L	\$ 1672	\$ 1732	\$ 1793
	66"W (RH)	GL5066R	\$ 1745	\$ 1809	\$ 1870
	66"W (LH)	GL5066L	\$ 1745	\$ 1809	\$ 1870
	72"W (RH)	GL5072R	\$ 1835	\$ 1902	\$ 1967
72"W (LH)	GL5072L	\$ 1835	\$ 1902	\$ 1967	
78"W (RH)	GL5078R	\$ 2113	\$ 2190	\$ 2266	
78"W (LH)	GL5078L	\$ 2113	\$ 2190	\$ 2266	
	50"H T- Gallery-to-Gallery Panels				
	18"W	GT5018	\$ 990	\$ 1027	\$ 1062
	21"W	GT5021	\$ 1013	\$ 1050	\$ 1087
	24"W	GT5024	\$ 1051	\$ 1091	\$ 1128
	27"W	GT5027	\$ 1092	\$ 1133	\$ 1172
	30"W	GT5030	\$ 1190	\$ 1234	\$ 1276
	36"W	GT5036	\$ 1294	\$ 1341	\$ 1388
	42"W	GT5042	\$ 1387	\$ 1437	\$ 1486
	48"W	GT5048	\$ 1503	\$ 1558	\$ 1612
	54"W	GT5054	\$ 1595	\$ 1653	\$ 1711
	60"W	GT5060	\$ 1673	\$ 1733	\$ 1794
	66"W	GT5066	\$ 1748	\$ 1812	\$ 1873
	72"W	GT5072	\$ 1834	\$ 1901	\$ 1966
78"W	GT5078	\$ 2112	\$ 2189	\$ 2265	
	50"H Nonsym T- Gallery-to-Gallery Panels				
	42"W 18L 24R	GT501824	\$ 1387	\$ 1437	\$ 1486
	42"W 24L 18R	GT502418	\$ 1387	\$ 1437	\$ 1486
	48"W 18L 30R	GT501830	\$ 1503	\$ 1558	\$ 1612
	48"W 30L 18R	GT503018	\$ 1503	\$ 1558	\$ 1612
	54"W 24L 30R	GT502430	\$ 1595	\$ 1653	\$ 1711
	54"W 30L 24R	GT503024	\$ 1595	\$ 1653	\$ 1711

Description	Model	List Price
Gallery-to-Gallery Installation Template (<i>Black only, code P</i>)	GTEMP	\$ 79

<p>How to specify — Select the Model Number from above.</p>	<p>1st Option: FSC: (if applicable): F FSC Wood X Non-FSC Wood</p>	<p>2nd Option: Laminate: (if applicable): See page 132 for finishes.</p>	<p>3rd Option: Edge: See page 132 for finishes.</p>	<p>4th Option: Grain: (if applicable): VLG Horizontal grain or Solid only. VST Vertical Grain (available only for single panels 60"W or less, and for split panels between 87"W and 117"W).</p>	<p>5th Option: Paint See page 132 for finishes.</p>	<p>6th Option: Glide: (if applicable):</p>
	<p>G . .</p>	<p> .</p>	<p> .</p>	<p>V .</p>	<p> .</p>	<p>G </p>

Description	Model	List Price		
		L1	L2	L3
57½"H L- Gallery-to-Gallery Panels				
18"W (RH)	GL5718R	\$ 1153	\$ 1196	\$ 1237
18"W (LH)	GL5718L	\$ 1153	\$ 1196	\$ 1237
21"W (RH)	GL5721R	\$ 1173	\$ 1216	\$ 1258
21"W (LH)	GL5721L	\$ 1173	\$ 1216	\$ 1258
24"W (RH)	GL5724R	\$ 1213	\$ 1258	\$ 1300
24"W (LH)	GL5724L	\$ 1213	\$ 1258	\$ 1300
27"W (RH)	GL5727R	\$ 1256	\$ 1302	\$ 1347
27"W (LH)	GL5727L	\$ 1256	\$ 1302	\$ 1347
30"W (RH)	GL5730R	\$ 1354	\$ 1403	\$ 1451
30"W (LH)	GL5730L	\$ 1354	\$ 1403	\$ 1451
36"W (RH)	GL5736R	\$ 1457	\$ 1510	\$ 1563
36"W (LH)	GL5736L	\$ 1457	\$ 1510	\$ 1563
42"W (RH)	GL5742R	\$ 1549	\$ 1605	\$ 1661
42"W (LH)	GL5742L	\$ 1549	\$ 1605	\$ 1661
48"W (RH)	GL5748R	\$ 1668	\$ 1728	\$ 1788
48"W (LH)	GL5748L	\$ 1668	\$ 1728	\$ 1788
54"W (RH)	GL5754R	\$ 1759	\$ 1823	\$ 1886
54"W (LH)	GL5754L	\$ 1759	\$ 1823	\$ 1886
60"W (RH)	GL5760R	\$ 1836	\$ 1903	\$ 1968
60"W (LH)	GL5760L	\$ 1836	\$ 1903	\$ 1968
66"W (RH)	GL5766R	\$ 1911	\$ 1981	\$ 2048
66"W (LH)	GL5766L	\$ 1911	\$ 1981	\$ 2048
72"W (RH)	GL5772R	\$ 1999	\$ 2072	\$ 2143
72"W (LH)	GL5772L	\$ 1999	\$ 2072	\$ 2143
78"W (RH)	GL5778R	\$ 2275	\$ 2358	\$ 2439
78"W (LH)	GL5778L	\$ 2275	\$ 2358	\$ 2439
57½"H T- Gallery-to-Gallery Panels				
18"W	GT5718	\$ 1151	\$ 1194	\$ 1235
21"W	GT5721	\$ 1175	\$ 1218	\$ 1260
24"W	GT5724	\$ 1213	\$ 1258	\$ 1300
27"W	GT5727	\$ 1256	\$ 1302	\$ 1347
30"W	GT5730	\$ 1355	\$ 1404	\$ 1452
36"W	GT5736	\$ 1456	\$ 1509	\$ 1562
42"W	GT5742	\$ 1550	\$ 1606	\$ 1662
48"W	GT5748	\$ 1669	\$ 1729	\$ 1789
54"W	GT5754	\$ 1757	\$ 1821	\$ 1884
60"W	GT5760	\$ 1835	\$ 1902	\$ 1967
66"W	GT5766	\$ 1910	\$ 1980	\$ 2047
72"W	GT5772	\$ 1998	\$ 2071	\$ 2142
78"W	GT5778	\$ 2276	\$ 2359	\$ 2440
57½"H Nonsym T- Gallery-to-Gallery Panels				
42"W 18L 24R	GT571824	\$ 1550	\$ 1606	\$ 1662
42"W 24L 18R	GT572418	\$ 1550	\$ 1606	\$ 1662
48"W 18L 30R	GT571830	\$ 1669	\$ 1729	\$ 1789
48"W 30L 18R	GT573018	\$ 1669	\$ 1729	\$ 1789
54"W 24L 30R	GT572430	\$ 1757	\$ 1821	\$ 1884
54"W 30L 24R	GT573024	\$ 1757	\$ 1821	\$ 1884

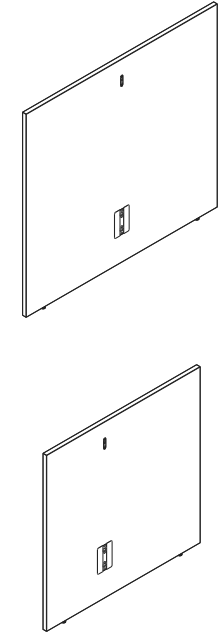
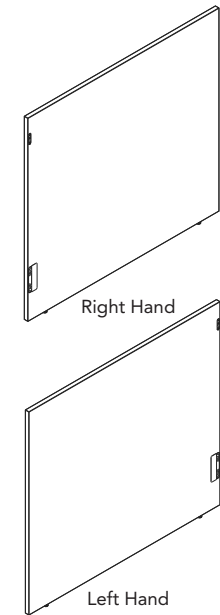

Description	Model	List Price
Gallery-to-Gallery Installation Template (Black only, code P)	GTEMP	\$ 79

<p>How to specify — Select the Model Number from above.</p> <p>G . .</p>	<p>1st Option: FSC: (if applicable): F FSC Wood X Non-FSC Wood</p>	<p>2nd Option: Laminate: (if applicable): See page 132 for finishes.</p>	<p>3rd Option: Edge: See page 132 for finishes.</p>	<p>4th Option: Grain: (if applicable): VLG Horizontal grain or Solid only. VST Vertical Grain (available only for single panels 60"W or less, and for split panels between 87"W and 117"W).</p>	<p>5th Option: Paint See page 132 for finishes.</p>	<p>6th Option: Glide: (if applicable):</p>
	<p> . .</p>	<p> .</p>	<p> .</p>	<p>V .</p>	<p> .</p>	<p>G .</p>

Gallery Panels

Gallery-to-Gallery Panels for use with Glass: 30" Application

GSA SIN 33721

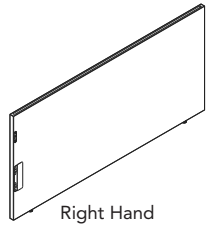

Right Hand

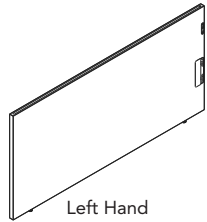

Left Hand

Description	Model	List Price			Accepts Glass Models 7½"H, 13"H, 15"H
		L1	L2	L3	
30"H L- Gallery-to-Gallery Panels For Use w/ Glass					
18"W (RH)	GL3018RG	\$ 959	\$ 995	\$ 1029	G4 □□ 18GS
18"W (LH)	GL3018LG	\$ 959	\$ 995	\$ 1029	G4 □□ 18GS
21"W (RH)	GL3021RG	\$ 974	\$ 1010	\$ 1045	G4 □□ 21GS
21"W (LH)	GL3021LG	\$ 974	\$ 1010	\$ 1045	G4 □□ 21GS
24"W (RH)	GL3024RG	\$ 1007	\$ 1044	\$ 1080	G4 □□ 24GS
24"W (LH)	GL3024LG	\$ 1007	\$ 1044	\$ 1080	G4 □□ 24GS
27"W (RH)	GL3027RG	\$ 1046	\$ 1084	\$ 1123	G4 □□ 27GS
27"W (LH)	GL3027LG	\$ 1046	\$ 1084	\$ 1123	G4 □□ 27GS
30"W (RH)	GL3030RG	\$ 1124	\$ 1166	\$ 1206	G4 □□ 30GS
30"W (LH)	GL3030LG	\$ 1124	\$ 1166	\$ 1206	G4 □□ 30GS
36"W (RH)	GL3036RG	\$ 1200	\$ 1244	\$ 1287	G4 □□ 36GS
36"W (LH)	GL3036LG	\$ 1200	\$ 1244	\$ 1287	G4 □□ 36GS
42"W (RH)	GL3042RG	\$ 1290	\$ 1337	\$ 1383	G4 □□ 42GS
42"W (LH)	GL3042LG	\$ 1290	\$ 1337	\$ 1383	G4 □□ 42GS
48"W (RH)	GL3048RG	\$ 1413	\$ 1465	\$ 1515	G4 □□ 48GS
48"W (LH)	GL3048LG	\$ 1413	\$ 1465	\$ 1515	G4 □□ 48GS
54"W (RH)	GL3054RG	\$ 1477	\$ 1531	\$ 1584	G4 □□ 54GS
54"W (LH)	GL3054LG	\$ 1477	\$ 1531	\$ 1584	G4 □□ 54GS
60"W (RH)	GL3060RG	\$ 1577	\$ 1634	\$ 1692	G4 □□ 60GS
60"W (LH)	GL3060LG	\$ 1577	\$ 1634	\$ 1692	G4 □□ 60GS
66"W (RH)	GL3066RG	\$ 1617	\$ 1676	\$ 1734	G4 □□ 66GS
66"W (LH)	GL3066LG	\$ 1617	\$ 1676	\$ 1734	G4 □□ 66GS
72"W (RH)	GL3072RG	\$ 1739	\$ 1801	\$ 1864	G4 □□ 72GS
72"W (LH)	GL3072LG	\$ 1739	\$ 1801	\$ 1864	G4 □□ 72GS
78"W (RH)	GL3078RG	\$ 1969	\$ 2041	\$ 2112	G4 □□ 78GS
78"W (LH)	GL3078LG	\$ 1969	\$ 2041	\$ 2112	G4 □□ 78GS

30"H T- Gallery-to-Gallery Panels For Use w/ Glass

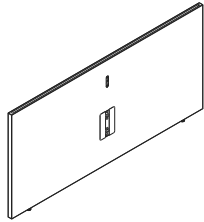

18"W	GT3018G	\$ 957	\$ 993	\$ 1027	G4 □□ 18GS
21"W	GT3021G	\$ 977	\$ 1013	\$ 1048	G4 □□ 21GS
24"W	GT3024G	\$ 1006	\$ 1043	\$ 1079	G4 □□ 24GS
27"W	GT3027G	\$ 1045	\$ 1083	\$ 1122	G4 □□ 27GS
30"W	GT3030G	\$ 1126	\$ 1168	\$ 1208	G4 □□ 30GS
36"W	GT3036G	\$ 1198	\$ 1242	\$ 1285	G4 □□ 36GS
42"W	GT3042G	\$ 1291	\$ 1338	\$ 1384	G4 □□ 42GS
48"W	GT3048G	\$ 1414	\$ 1466	\$ 1516	G4 □□ 48GS
54"W	GT3054G	\$ 1478	\$ 1532	\$ 1585	G4 □□ 54GS
60"W	GT3060G	\$ 1574	\$ 1631	\$ 1689	G4 □□ 60GS
66"W	GT3066G	\$ 1616	\$ 1675	\$ 1733	G4 □□ 66GS
72"W	GT3072G	\$ 1740	\$ 1802	\$ 1865	G4 □□ 72GS
78"W	GT3078G	\$ 1970	\$ 2042	\$ 2113	G4 □□ 78GS

30"H Nonsym T- Gallery-to-Gallery Panels For Use w/ Glass

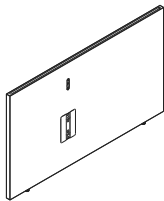

42"W 18L 24R	GT301824G	\$ 1291	\$ 1338	\$ 1384	G4 □□ 42GS
42"W 24L 18R	GT302418G	\$ 1291	\$ 1338	\$ 1384	G4 □□ 42GS
48"W 18L 30R	GT301830G	\$ 1414	\$ 1466	\$ 1516	G4 □□ 48GS
48"W 30L 18R	GT303018G	\$ 1414	\$ 1466	\$ 1516	G4 □□ 48GS
54"W 24L 30R	GT302430G	\$ 1478	\$ 1532	\$ 1585	G4 □□ 54GS
54"W 30L 24R	GT303024G	\$ 1478	\$ 1532	\$ 1585	G4 □□ 54GS

Note: Fill in model number blanks with one of the following options to determine glass height.

07 7.5"H glass

13 13"H glass

15 15"H glass

Description	Model	List Price
Gallery-to-Gallery Installation Template (Black only, code P)	GTEMP	\$ 79

How to specify —
Select the Model Number from above.

1st Option:

FSC:
(if applicable):

F FSC Wood
X Non-FSC Wood

2nd Option:

Laminate: (if applicable):
See page 132 for finishes.

3rd Option:

Edge:
See page 132 for finishes.

4th Option:

Grain: (if applicable):
VLG Horizontal grain or Solid only.
VST Vertical Grain (available only for single panels 60"W or less, and for split panels between 87"W and 117"W).

5th Option:

Paint
See page 132 for finishes.

6th Option:

Glide: (if applicable):

G | | | | V | | G

Gallery Panels

Gallery-to-Gallery Panels for use with Glass: 35" Application

GSA SIN 33721

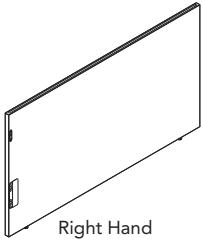
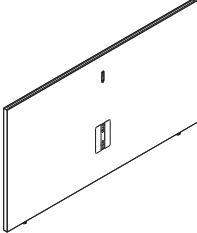
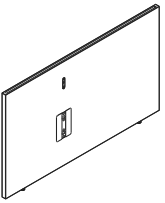
Description	Model	List Price			Accepts Glass Models 7½"H, 13"H, 15"H	
		L1	L2	L3		
35"H L- Gallery-to-Gallery Panels For Use w/ Glass						
 Right Hand	18"W (RH)	GL3518RG	1049	1089	1126	G4 □□ 18GS
	18"W (LH)	GL3518LG	1049	1089	1126	G4 □□ 18GS
	21"W (RH)	GL3521RG	1071	1111	1149	G4 □□ 21GS
	21"W (LH)	GL3521LG	1071	1111	1149	G4 □□ 21GS
	24"W (RH)	GL3524RG	1108	1149	1189	G4 □□ 24GS
	24"W (LH)	GL3524LG	1108	1149	1189	G4 □□ 24GS
	27"W (RH)	GL3527RG	1142	1184	1225	G4 □□ 27GS
	27"W (LH)	GL3527LG	1142	1184	1225	G4 □□ 27GS
	30"W (RH)	GL3530RG	1244	1290	1334	G4 □□ 30GS
	30"W (LH)	GL3530LG	1244	1290	1334	G4 □□ 30GS
	36"W (RH)	GL3536RG	1335	1384	1431	G4 □□ 36GS
	36"W (LH)	GL3536LG	1335	1384	1431	G4 □□ 36GS
	42"W (RH)	GL3542RG	1401	1453	1503	G4 □□ 42GS
	42"W (LH)	GL3542LG	1401	1453	1503	G4 □□ 42GS
	48"W (RH)	GL3548RG	1505	1560	1614	G4 □□ 48GS
	48"W (LH)	GL3548LG	1505	1560	1614	G4 □□ 48GS
	54"W (RH)	GL3554RG	1581	1638	1696	G4 □□ 54GS
	54"W (LH)	GL3554LG	1581	1638	1696	G4 □□ 54GS
	60"W (RH)	GL3560RG	1666	1726	1786	G4 □□ 60GS
	60"W (LH)	GL3560LG	1666	1726	1786	G4 □□ 60GS
	66"W (RH)	GL3566RG	1730	1792	1854	G4 □□ 66GS
	66"W (LH)	GL3566LG	1730	1792	1854	G4 □□ 66GS
	72"W (RH)	GL3572RG	1855	1922	1988	G4 □□ 72GS
	72"W (LH)	GL3572LG	1855	1922	1988	G4 □□ 72GS
	78"W (RH)	GL3578RG	2044	2118	2191	G4 □□ 78GS
	78"W (LH)	GL3578LG	2044	2118	2191	G4 □□ 78GS
	Left Hand					
35"H T- Gallery-to-Gallery Panels For Use w/ Glass						
	18"W	GT3518G	1051	1091	1128	G4 □□ 18GS
	21"W	GT3521G	1069	1109	1147	G4 □□ 21GS
	24"W	GT3524G	1107	1148	1188	G4 □□ 24GS
	27"W	GT3527G	1141	1183	1224	G4 □□ 27GS
	30"W	GT3530G	1246	1292	1336	G4 □□ 30GS
	36"W	GT3536G	1333	1382	1429	G4 □□ 36GS
	42"W	GT3542G	1403	1455	1505	G4 □□ 42GS
	48"W	GT3548G	1503	1558	1612	G4 □□ 48GS
	54"W	GT3554G	1581	1638	1696	G4 □□ 54GS
	60"W	GT3560G	1668	1728	1788	G4 □□ 60GS
	66"W	GT3566G	1730	1792	1854	G4 □□ 66GS
	72"W	GT3572G	1856	1923	1989	G4 □□ 72GS
	78"W	GT3578G	2042	2116	2189	G4 □□ 78GS
35"H Nonsym T- Gallery-to-Gallery Panels For Use w/ Glass						
	42"W 18L 24R	GT351824G	1403	1455	1505	G4 □□ 42GS
	42"W 24L 18R	GT352418G	1403	1455	1505	G4 □□ 42GS
	48"W 18L 30R	GT351830G	1503	1558	1612	G4 □□ 48GS
	48"W 30L 18R	GT353018G	1503	1558	1612	G4 □□ 48GS
	54"W 24L 30R	GT352430G	1581	1638	1696	G4 □□ 54GS
	54"W 30L 24R	GT353024G	1581	1638	1696	G4 □□ 54GS
Note: Fill in model number blanks with one of the following options to determine glass height.						
07 7.5"H glass						
13 13"H glass						
15 15"H glass						

Description	Model	List Price
Gallery-to-Gallery Installation Template (Black only, code P)	GTEMP	\$ 79

How to specify — Select the Model Number from above.	1st Option: FSC: (if applicable): F FSC Wood X Non-FSC Wood	2nd Option: Laminate: (if applicable): See page 132 for finishes.	3rd Option: Edge: See page 132 for finishes.	4th Option: Grain: (if applicable): VLG Horizontal grain or Solid only. VST Vertical Grain (available only for single panels 60" W or less, and for split panels between 87" W and 117" W.	5th Option: Paint See page 132 for finishes.	6th Option: Glide: (if applicable):
	G 	V .	.

Gallery Panels

Gallery-to-Gallery Panels for use with Glass: 42" Application

GSA SIN 33721

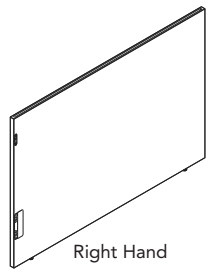

Right Hand

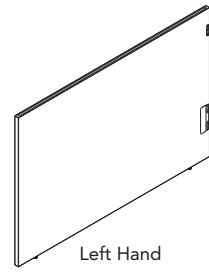

Left Hand

Description	Model	List Price			Accepts Glass Models 7½"H, 13"H, 15"H
		L1	L2	L3	
42"H L- Gallery-to-Gallery Panels For Use w/ Glass					
18"W (RH)	GL4218RG	1120	1162	1202	G4 □□ 18GS
18"W (LH)	GL4218LG	1120	1162	1202	G4 □□ 18GS
21"W (RH)	GL4221RG	1134	1176	1216	G4 □□ 21GS
21"W (LH)	GL4221LG	1134	1176	1216	G4 □□ 21GS
24"W (RH)	GL4224RG	1183	1227	1268	G4 □□ 24GS
24"W (LH)	GL4224LG	1183	1227	1268	G4 □□ 24GS
27"W (RH)	GL4227RG	1224	1269	1313	G4 □□ 27GS
27"W (LH)	GL4227LG	1224	1269	1313	G4 □□ 27GS
30"W (RH)	GL4230RG	1337	1386	1433	G4 □□ 30GS
30"W (LH)	GL4230LG	1337	1386	1433	G4 □□ 30GS
36"W (RH)	GL4236RG	1436	1489	1541	G4 □□ 36GS
36"W (LH)	GL4236LG	1436	1489	1541	G4 □□ 36GS
42"W (RH)	GL4242RG	1518	1573	1628	G4 □□ 42GS
42"W (LH)	GL4242LG	1518	1573	1628	G4 □□ 42GS
48"W (RH)	GL4248RG	1602	1660	1718	G4 □□ 48GS
48"W (LH)	GL4248LG	1602	1660	1718	G4 □□ 48GS
54"W (RH)	GL4254RG	1710	1772	1833	G4 □□ 54GS
54"W (LH)	GL4254LG	1710	1772	1833	G4 □□ 54GS
60"W (RH)	GL4260RG	1791	1856	1920	G4 □□ 60GS
60"W (LH)	GL4260LG	1791	1856	1920	G4 □□ 60GS
66"W (RH)	GL4266RG	1873	1941	2007	G4 □□ 66GS
66"W (LH)	GL4266LG	1873	1941	2007	G4 □□ 66GS
72"W (RH)	GL4272RG	1986	2058	2130	G4 □□ 72GS
72"W (LH)	GL4272LG	1986	2058	2130	G4 □□ 72GS
78"W (RH)	GL4278RG	2140	2218	2294	G4 □□ 78GS
78"W (LH)	GL4278LG	2140	2218	2294	G4 □□ 78GS

42"H T- Gallery-to-Gallery Panels For Use w/ Glass

18"W	GT4218G	1121	1163	1203	G4 □□ 18GS
21"W	GT4221G	1137	1179	1219	G4 □□ 21GS
24"W	GT4224G	1183	1227	1268	G4 □□ 24GS
27"W	GT4227G	1222	1267	1311	G4 □□ 27GS
30"W	GT4230G	1340	1389	1436	G4 □□ 30GS
36"W	GT4236G	1438	1491	1543	G4 □□ 36GS
42"W	GT4242G	1518	1573	1628	G4 □□ 42GS
48"W	GT4248G	1601	1659	1717	G4 □□ 48GS
54"W	GT4254G	1711	1773	1834	G4 □□ 54GS
60"W	GT4260G	1791	1856	1920	G4 □□ 60GS
66"W	GT4266G	1872	1940	2006	G4 □□ 66GS
72"W	GT4272G	1985	2057	2129	G4 □□ 72GS
78"W	GT4278G	2139	2217	2293	G4 □□ 78GS

42"H Nonsym T- Gallery-to-Gallery Panels For Use w/ Glass

42"W 18L 24R	GT421824G	1518	1573	1628	G4 □□ 42GS
42"W 24L 18R	GT422418G	1518	1573	1628	G4 □□ 42GS
48"W 18L 30R	GT421830G	1601	1659	1717	G4 □□ 48GS
48"W 30L 18R	GT423018G	1601	1659	1717	G4 □□ 48GS
54"W 24L 30R	GT422430G	1711	1773	1834	G4 □□ 54GS
54"W 30L 24R	GT423024G	1711	1773	1834	G4 □□ 54GS

Note: Fill in model number blanks with one of the following options to determine glass height.

- 07 7.5"H glass
- 13 13"H glass
- 15 15"H glass

Description	Model	List Price
Gallery-to-Gallery Installation Template (<i>Black only, code P</i>)	GTEMP	\$ 79

<p>How to specify — Select the Model Number from above.</p>	<p><i>1st Option:</i> FSC: (if applicable): F FSC Wood X Non-FSC Wood</p>	<p><i>2nd Option:</i> Laminate: (if applicable): See page 132 for finishes.</p>	<p><i>3rd Option:</i> Edge: See page 132 for finishes.</p>	<p><i>4th Option:</i> Grain: (if applicable): VLG Horizontal grain or Solid only. VST Vertical Grain (available only for single panels 60"W or less, and for split panels between 87"W and 117"W).</p>	<p><i>5th Option:</i> Paint See page 132 for finishes.</p>	<p><i>6th Option:</i> Glide: (if applicable):</p>
	<p>G . .</p>	<p> .</p>	<p> .</p>	<p>V .</p>	<p> .</p>	<p>G </p>

GALLERY PANELS

Gallery Panels

Gallery-to-Gallery Panels for use with Glass: 50" Application

GSA SIN 33721

Description	Model	List Price			Accepts Glass Models 7½"H, 13"H, 15"H
		L1	L2	L3	
50"H L- Gallery-to-Gallery Panels For Use w/ Glass					
18"W (RH)	GL5018RG	1229	1274	1318	G4 □□ 18GS
18"W (LH)	GL5018LG	1229	1274	1318	G4 □□ 18GS
21"W (RH)	GL5021RG	1251	1297	1342	G4 □□ 21GS
21"W (LH)	GL5021LG	1251	1297	1342	G4 □□ 21GS
24"W (RH)	GL5024RG	1290	1337	1383	G4 □□ 24GS
24"W (LH)	GL5024LG	1290	1337	1383	G4 □□ 24GS
27"W (RH)	GL5027RG	1334	1383	1430	G4 □□ 27GS
27"W (LH)	GL5027LG	1334	1383	1430	G4 □□ 27GS
30"W (RH)	GL5030RG	1432	1485	1535	G4 □□ 30GS
30"W (LH)	GL5030LG	1432	1485	1535	G4 □□ 30GS
36"W (RH)	GL5036RG	1534	1590	1645	G4 □□ 36GS
36"W (LH)	GL5036LG	1534	1590	1645	G4 □□ 36GS
42"W (RH)	GL5042RG	1627	1686	1745	G4 □□ 42GS
42"W (LH)	GL5042LG	1627	1686	1745	G4 □□ 42GS
48"W (RH)	GL5048RG	1744	1808	1869	G4 □□ 48GS
48"W (LH)	GL5048LG	1744	1808	1869	G4 □□ 48GS
54"W (RH)	GL5054RG	1835	1902	1967	G4 □□ 54GS
54"W (LH)	GL5054LG	1835	1902	1967	G4 □□ 54GS
60"W (RH)	GL5060RG	1913	1983	2050	G4 □□ 60GS
60"W (LH)	GL5060LG	1913	1983	2050	G4 □□ 60GS
66"W (RH)	GL5066RG	1987	2059	2131	G4 □□ 66GS
66"W (LH)	GL5066LG	1987	2059	2131	G4 □□ 66GS
72"W (RH)	GL5072RG	2074	2149	2223	G4 □□ 72GS
72"W (LH)	GL5072LG	2074	2149	2223	G4 □□ 72GS
78"W (RH)	GL5078RG	2352	2437	2521	G4 □□ 78GS
78"W (LH)	GL5078LG	2352	2437	2521	G4 □□ 78GS
50"H T- Gallery-to-Gallery Panels For Use w/ Glass					
18"W	GT5018G	1230	1275	1319	G4 □□ 18GS
21"W	GT5021G	1251	1297	1342	G4 □□ 21GS
24"W	GT5024G	1291	1338	1384	G4 □□ 24GS
27"W	GT5027G	1332	1381	1428	G4 □□ 27GS
30"W	GT5030G	1432	1485	1535	G4 □□ 30GS
36"W	GT5036G	1534	1590	1645	G4 □□ 36GS
42"W	GT5042G	1627	1686	1745	G4 □□ 42GS
48"W	GT5048G	1744	1808	1869	G4 □□ 48GS
54"W	GT5054G	1834	1901	1966	G4 □□ 54GS
60"W	GT5060G	1912	1982	2049	G4 □□ 60GS
66"W	GT5066G	1986	2058	2130	G4 □□ 66GS
72"W	GT5072G	2074	2149	2223	G4 □□ 72GS
78"W	GT5078G	2353	2438	2522	G4 □□ 78GS
50"H Nonsym T- Gallery-to-Gallery Panels For Use w/ Glass					
42"W 18L 24R	GT501824G	1627	1686	1745	G4 □□ 42GS
42"W 24L 18R	GT502418G	1627	1686	1745	G4 □□ 42GS
48"W 18L 30R	GT501830G	1744	1808	1869	G4 □□ 48GS
48"W 30L 18R	GT503018G	1744	1808	1869	G4 □□ 48GS
54"W 24L 30R	GT502430G	1834	1901	1966	G4 □□ 54GS
54"W 30L 24R	GT503024G	1834	1901	1966	G4 □□ 54GS
Note: Fill in model number blanks with one of the following options to determine glass height.					
07 7.5"H glass					
13 13"H glass					
15 15"H glass					

Description	Model	List Price
Gallery-to-Gallery Installation Template (Black only, code P)	GTEMP	\$ 79

How to specify — Select the Model Number from above.	1st Option: FSC: (if applicable): F FSC Wood X Non-FSC Wood	2nd Option: Laminate: (if applicable): See page 132 for finishes.	3rd Option: Edge: See page 132 for finishes.	4th Option: Grain: (if applicable): VLG Horizontal grain or Solid only. VST Vertical Grain (available only for single panels 60"W or less, and for split panels between 87"W and 117"W.	5th Option: Paint See page 132 for finishes.	6th Option: Glide: (if applicable):
	G 	V .	.

Gallery Panels

Gallery-to-Gallery Panels for use with Glass: 57½" Application

GSA SIN 33721

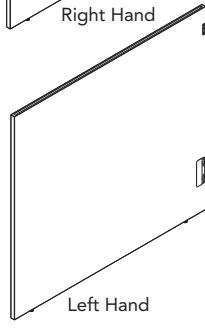
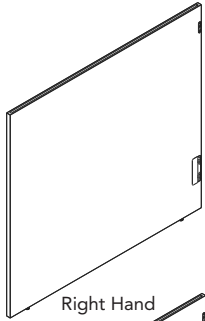

Description	Model	List Price			Accepts Glass Models 7½"H, 13"H, 15"H
		L1	L2	L3	
57½"H L- Gallery-to-Gallery Panels For Use w/ Glass					
18" W (RH)	GL5718RG	1392	1442	1493	G4 □ □ 18GS
18" W (LH)	GL5718LG	1392	1442	1493	G4 □ □ 18GS
21" W (RH)	GL5721RG	1414	1466	1516	G4 □ □ 21GS
21" W (LH)	GL5721LG	1414	1466	1516	G4 □ □ 21GS
24" W (RH)	GL5724RG	1454	1507	1560	G4 □ □ 24GS
24" W (LH)	GL5724LG	1454	1507	1560	G4 □ □ 24GS
27" W (RH)	GL5727RG	1496	1551	1604	G4 □ □ 27GS
27" W (LH)	GL5727LG	1496	1551	1604	G4 □ □ 27GS
30" W (RH)	GL5730RG	1594	1652	1710	G4 □ □ 30GS
30" W (LH)	GL5730LG	1594	1652	1710	G4 □ □ 30GS
36" W (RH)	GL5736RG	1696	1757	1818	G4 □ □ 36GS
36" W (LH)	GL5736LG	1696	1757	1818	G4 □ □ 36GS
42" W (RH)	GL5742RG	1790	1855	1919	G4 □ □ 42GS
42" W (LH)	GL5742LG	1790	1855	1919	G4 □ □ 42GS
48" W (RH)	GL5748RG	1909	1979	2046	G4 □ □ 48GS
48" W (LH)	GL5748LG	1909	1979	2046	G4 □ □ 48GS
54" W (RH)	GL5754RG	1999	2072	2143	G4 □ □ 54GS
54" W (LH)	GL5754LG	1999	2072	2143	G4 □ □ 54GS
60" W (RH)	GL5760RG	2077	2152	2226	G4 □ □ 60GS
60" W (LH)	GL5760LG	2077	2152	2226	G4 □ □ 60GS
66" W (RH)	GL5766RG	2150	2229	2305	G4 □ □ 66GS
66" W (LH)	GL5766LG	2150	2229	2305	G4 □ □ 66GS
72" W (RH)	GL5772RG	2238	2319	2399	G4 □ □ 72GS
72" W (LH)	GL5772LG	2238	2319	2399	G4 □ □ 72GS
78" W (RH)	GL5778RG	2515	2606	2696	G4 □ □ 78GS
78" W (LH)	GL5778LG	2515	2606	2696	G4 □ □ 78GS

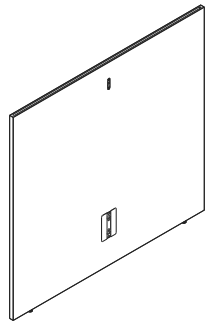

57½"H T- Gallery-to-Gallery Panels For Use w/ Glass					
18"W	GT5718G	1392	1442	1493	G4 □ □ 18GS
21"W	GT5721G	1415	1467	1517	G4 □ □ 21GS
24"W	GT5724G	1454	1507	1560	G4 □ □ 24GS
27"W	GT5727G	1496	1551	1604	G4 □ □ 27GS
30"W	GT5730G	1595	1653	1711	G4 □ □ 30GS
36"W	GT5736G	1696	1757	1818	G4 □ □ 36GS
42"W	GT5742G	1790	1855	1919	G4 □ □ 42GS
48"W	GT5748G	1908	1978	2045	G4 □ □ 48GS
54"W	GT5754G	1998	2071	2142	G4 □ □ 54GS
60"W	GT5760G	2076	2151	2225	G4 □ □ 60GS
66"W	GT5766G	2149	2228	2304	G4 □ □ 66GS
72"W	GT5772G	2238	2319	2399	G4 □ □ 72GS
78"W	GT5778G	2515	2606	2696	G4 □ □ 78GS

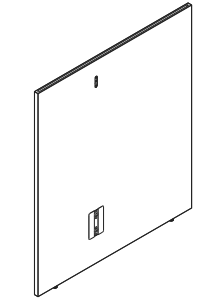

57½"H Nonsym T- Gallery-to-Gallery Panels For Use w/ Glass					
42"W 18L 24R	GT571824G	1790	1855	1919	G4 □ □ 42GS
42"W 24L 18R	GT572418G	1790	1855	1919	G4 □ □ 42GS
48"W 18L 30R	GT571830G	1908	1978	2045	G4 □ □ 48GS
48"W 30L 18R	GT573018G	1908	1978	2045	G4 □ □ 48GS
54"W 24L 30R	GT572430G	1998	2071	2142	G4 □ □ 54GS
54"W 30L 24R	GT573024G	1998	2071	2142	G4 □ □ 54GS

Note: Fill in model number blanks with one of the following options to determine glass height.

- 07** 7.5"H glass
- 13** 13"H glass
- 15** 15"H glass

Description	Model	List Price
Gallery-to-Gallery Installation Template (Black only, code P)	GTEMP	\$ 79

How to specify — Select the Model Number from above. G . .	1st Option: FSC: (if applicable): F FSC Wood X Non-FSC Wood	2nd Option: Laminate: (if applicable): See page 132 for finishes.	3rd Option: Edge: See page 132 for finishes.	4th Option: Grain: (if applicable): VLG Horizontal grain or Solid only. VST Vertical Grain (available only for single panels 60"W or less, and for split panels between 87"W and 117"W).	5th Option: Paint See page 132 for finishes.	6th Option: Glide: (if applicable): G
--	--	---	--	---	--	--

Gallery Panels

30"H Application

For Gallery Panel connectors see page 171.

GSA SIN 33721

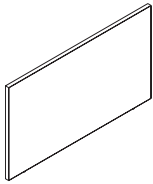

Description	Model	Configuration	List Price		
			L1	L2	L3
30"H Gallery Panels					
18"W	G3018	Mid	\$ 479	\$ 497	\$ 513
21"W	G3021	Mid	\$ 498	\$ 517	\$ 534
24"W	G3024	Mid	\$ 529	\$ 549	\$ 567
27"W	G3027	Mid	\$ 567	\$ 588	\$ 609
30"W	G3030	Mid	\$ 646	\$ 669	\$ 693
33"W	G3033	S, Mid	\$ 685	\$ 710	\$ 734
36"W	G3036	S, Mid	\$ 720	\$ 747	\$ 772
39"W	G3039	S, Mid	\$ 782	\$ 811	\$ 838
42"W	G3042	S, Mid	\$ 846	\$ 876	\$ 906
45"W	G3045	S, Mid	\$ 923	\$ 956	\$ 989
48"W	G3048	S, Mid	\$ 967	\$ 1001	\$ 1037
51"W	G3051	D, S, Mid	\$ 983	\$ 1019	\$ 1054
54"W	G3054	D, S, Mid	\$ 1030	\$ 1067	\$ 1104
57"W	G3057	D, S, Mid	\$ 1076	\$ 1116	\$ 1153
60"W	G3060	D, S, Mid	\$ 1128	\$ 1169	\$ 1209
63"W	G3063	D, S, Mid	\$ 1148	\$ 1190	\$ 1230
66"W	G3066	D, S, Mid	\$ 1173	\$ 1216	\$ 1256
69"W	G3069	D, S, Mid	\$ 1256	\$ 1301	\$ 1346
72"W	G3072	D, S, Mid	\$ 1292	\$ 1338	\$ 1384
75"W	G3075	D, S, Mid	\$ 1465	\$ 1518	\$ 1570
78"W	G3078	D, S, Mid	\$ 1522	\$ 1577	\$ 1630
81"W	G3081	D, S, Mid	\$ 1575	\$ 1631	\$ 1687
84"W	G3084	D, S, Mid	\$ 1731	\$ 1792	\$ 1853

Note: Configuration is not included in model number

- Mid** Mid Panel
- S** End Single Sided
- D** End Dual Sided

<p>How to specify — Select the Model Number from above.</p>	<p>1st Option: FSC: F FSC Wood X Non-FSC Wood</p>	<p>2nd Option: Laminate: See page 132 for finishes.</p>	<p>3rd Option: Edge: See page 132 for finishes.</p>	<p>4th Option: Grain: VLG Horizontal grain or Solid only. VST Vertical Grain (available only for single panels 60"W or less, and for split panels between 87"W and 117"W).</p>	<p>5th Option: Glide:</p>
<p>G . .</p>				<p>V .</p>	<p>G </p>

Example: G3018.X.LT11.TI.VLG.G

Gallery Panels

35"H Application

For Gallery Panel connectors see page 171.

GSA SIN 33721

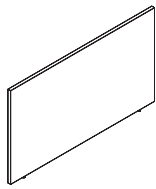

Description	Model	Configuration	List Price		
			L1	L2	L3
35"H Gallery Panels					
18"W	G3518	Mid	\$ 575	\$ 597	\$ 618
21"W	G3521	Mid	\$ 594	\$ 616	\$ 638
24"W	G3524	Mid	\$ 631	\$ 655	\$ 678
27"W	G3527	Mid	\$ 666	\$ 691	\$ 715
30"W	G3530	Mid	\$ 770	\$ 799	\$ 827
33"W	G3533	S, Mid	\$ 811	\$ 841	\$ 870
36"W	G3536	S, Mid	\$ 860	\$ 892	\$ 922
39"W	G3539	S, Mid	\$ 918	\$ 952	\$ 985
42"W	G3542	S, Mid	\$ 959	\$ 995	\$ 1030
45"W	G3545	S, Mid	\$ 1018	\$ 1056	\$ 1092
48"W	G3548	S, Mid	\$ 1062	\$ 1102	\$ 1140
51"W	G3551	D, S, Mid	\$ 1098	\$ 1139	\$ 1178
54"W	G3554	D, S, Mid	\$ 1138	\$ 1181	\$ 1221
57"W	G3557	D, S, Mid	\$ 1184	\$ 1228	\$ 1270
60"W	G3560	D, S, Mid	\$ 1222	\$ 1267	\$ 1311
63"W	G3563	D, S, Mid	\$ 1250	\$ 1296	\$ 1341
66"W	G3566	D, S, Mid	\$ 1286	\$ 1333	\$ 1379
69"W	G3569	D, S, Mid	\$ 1348	\$ 1397	\$ 1445
72"W	G3572	D, S, Mid	\$ 1411	\$ 1463	\$ 1513
75"W	G3575	D, S, Mid	\$ 1521	\$ 1577	\$ 1631
78"W	G3578	D, S, Mid	\$ 1600	\$ 1658	\$ 1716
81"W	G3581	D, S, Mid	\$ 1720	\$ 1782	\$ 1844
84"W	G3584	D, S, Mid	\$ 1883	\$ 1951	\$ 2018

Note: Configuration is not included in model number

- Mid** Mid Panel
- S** End Single Sided
- D** End Dual Sided

How to specify —
Select the Model Number from above.

1st Option:

- FSC:**
F FSC Wood
X Non-FSC Wood

2nd Option:

Laminate:
See page 132 for finishes.

3rd Option:

Edge:
See page 132 for finishes.

4th Option:

Grain:
VLG Horizontal grain or Solid only.
VST Vertical Grain (available only for single panels 60"W or less, and for split panels between 87"W and 117"W).

5th Option:

Glide:

G | | | | | | | | | | . | | .

| | | | | | | | .

| | | .

V | | | .

G |

Example: G3518.X.LT11.TI.VLG.G

Gallery Panels

42"H Application

For Gallery Panel connectors see page 171.

GSA SIN 33721

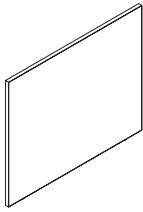

Description	Model	Configuration	List Price		
			L1	L2	L3
42"H Gallery Panels					
18"W	G4218	Mid	\$ 642	\$ 665	\$ 688
21"W	G4221	Mid	\$ 660	\$ 684	\$ 707
24"W	G4224	Mid	\$ 705	\$ 730	\$ 755
27"W	G4227	Mid	\$ 746	\$ 773	\$ 800
30"W	G4230	Mid	\$ 861	\$ 892	\$ 922
33"W	G4233	S, Mid	\$ 906	\$ 938	\$ 971
36"W	G4236	S, Mid	\$ 959	\$ 993	\$ 1027
39"W	G4239	S, Mid	\$ 1027	\$ 1064	\$ 1100
42"W	G4242	S, Mid	\$ 1071	\$ 1111	\$ 1148
45"W	G4245	S, Mid	\$ 1110	\$ 1151	\$ 1190
48"W	G4248	S, Mid	\$ 1155	\$ 1197	\$ 1237
51"W	G4251	D, S, Mid	\$ 1228	\$ 1272	\$ 1315
54"W	G4254	D, S, Mid	\$ 1266	\$ 1312	\$ 1356
57"W	G4257	D, S, Mid	\$ 1297	\$ 1344	\$ 1389
60"W	G4260	D, S, Mid	\$ 1346	\$ 1394	\$ 1441
63"W	G4263	D, S, Mid	\$ 1382	\$ 1431	\$ 1480
66"W	G4266	D, S, Mid	\$ 1427	\$ 1479	\$ 1528
69"W	G4269	D, S, Mid	\$ 1455	\$ 1508	\$ 1558
72"W	G4272	D, S, Mid	\$ 1538	\$ 1593	\$ 1647
75"W	G4275	D, S, Mid	\$ 1593	\$ 1650	\$ 1706
78"W	G4278	D, S, Mid	\$ 1693	\$ 1753	\$ 1813
81"W	G4281	D, S, Mid	\$ 1891	\$ 1958	\$ 2024
84"W	G4284	D, S, Mid	\$ 2036	\$ 2109	\$ 2180

Note: Configuration is not included in model number

- Mid** Mid Panel
- S** End Single Sided
- D** End Dual Sided

<p>How to specify — Select the Model Number from above.</p>	<p>1st Option: FSC: F FSC Wood X Non-FSC Wood</p>	<p>2nd Option: Laminate: See page 132 for finishes.</p>	<p>3rd Option: Edge: See page 132 for finishes.</p>	<p>4th Option: Grain: VLG Horizontal grain or Solid only. VST Vertical Grain (available only for single panels 60"W or less, and for split panels between 87"W and 117"W).</p>	<p>5th Option: Glide:</p>
G 	V .	G .

Example: G4218.X.LT11.TI.VLG.G

Gallery Panels

50"H Application

For Gallery Panel connectors see page 171.

GSA SIN 33721

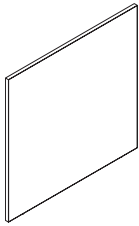

Description	Model	Configuration	List Price		
			L1	L2	L3
50"H Gallery Panels					
18"W	G5018	Mid	\$ 752	\$ 780	\$ 806
21"W	G5021	Mid	\$ 775	\$ 803	\$ 831
24"W	G5024	Mid	\$ 812	\$ 841	\$ 870
27"W	G5027	Mid	\$ 857	\$ 888	\$ 918
30"W	G5030	Mid	\$ 955	\$ 989	\$ 1023
33"W	G5033	S, Mid	\$ 1005	\$ 1041	\$ 1077
36"W	G5036	S, Mid	\$ 1054	\$ 1092	\$ 1129
39"W	G5039	S, Mid	\$ 1119	\$ 1160	\$ 1199
42"W	G5042	S, Mid	\$ 1179	\$ 1222	\$ 1263
45"W	G5045	S, Mid	\$ 1266	\$ 1312	\$ 1356
48"W	G5048	S, Mid	\$ 1297	\$ 1344	\$ 1389
51"W	G5051	D, S, Mid	\$ 1332	\$ 1380	\$ 1426
54"W	G5054	D, S, Mid	\$ 1388	\$ 1437	\$ 1486
57"W	G5057	D, S, Mid	\$ 1424	\$ 1476	\$ 1525
60"W	G5060	D, S, Mid	\$ 1466	\$ 1519	\$ 1571
63"W	G5063	D, S, Mid	\$ 1498	\$ 1552	\$ 1605
66"W	G5066	D, S, Mid	\$ 1539	\$ 1594	\$ 1648
69"W	G5069	D, S, Mid	\$ 1585	\$ 1642	\$ 1697
72"W	G5072	D, S, Mid	\$ 1628	\$ 1686	\$ 1744
75"W	G5075	D, S, Mid	\$ 1737	\$ 1798	\$ 1860
78"W	G5078	D, S, Mid	\$ 1907	\$ 1975	\$ 2041
81"W	G5081	D, S, Mid	\$ 2069	\$ 2143	\$ 2216
84"W	G5084	D, S, Mid	\$ 2212	\$ 2291	\$ 2368

Note: Configuration is not included in model number

- Mid** Mid Panel
- S** End Single Sided
- D** End Dual Sided

How to specify —
Select the Model Number from above.

1st Option:

- FSC:**
F FSC Wood
X Non-FSC Wood

2nd Option:

Laminate:
See page 132 for finishes.

3rd Option:

Edge:
See page 132 for finishes.

4th Option:

Grain:
VLG Horizontal grain or Solid only.
VST Vertical Grain (available only for single panels 60"W or less, and for split panels between 87"W and 117"W).

5th Option:

Glide:

G | | | | | | | | | | . | | .

| | | | | | | | .

| | | .

V | | | .

G |

Example: G5018.X.LT11.TI.VLG.G

Gallery Panels

57½"H Application

For Gallery Panel connectors see page 171.

GSA SIN 33721

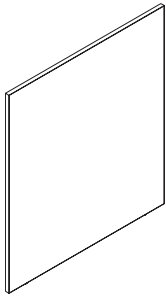

Description	Model	Configuration	List Price		
			L1	L2	L3
57½"H Gallery Panels					
18"W	G5718	Mid	\$ 915	\$ 948	\$ 980
21"W	G5721	Mid	\$ 937	\$ 970	\$ 1004
24"W	G5724	Mid	\$ 974	\$ 1010	\$ 1044
27"W	G5727	Mid	\$ 1018	\$ 1055	\$ 1091
30"W	G5730	Mid	\$ 1118	\$ 1159	\$ 1198
33"W	G5733	S, Mid	\$ 1165	\$ 1208	\$ 1248
36"W	G5736	S, Mid	\$ 1218	\$ 1262	\$ 1304
39"W	G5739	S, Mid	\$ 1284	\$ 1330	\$ 1375
42"W	G5742	S, Mid	\$ 1345	\$ 1393	\$ 1440
45"W	G5745	S, Mid	\$ 1428	\$ 1480	\$ 1529
48"W	G5748	S, Mid	\$ 1462	\$ 1515	\$ 1567
51"W	G5751	D, S, Mid	\$ 1496	\$ 1550	\$ 1603
54"W	G5754	D, S, Mid	\$ 1551	\$ 1607	\$ 1661
57"W	G5757	D, S, Mid	\$ 1587	\$ 1644	\$ 1699
60"W	G5760	D, S, Mid	\$ 1629	\$ 1687	\$ 1745
63"W	G5763	D, S, Mid	\$ 1661	\$ 1720	\$ 1779
66"W	G5766	D, S, Mid	\$ 1703	\$ 1763	\$ 1824
69"W	G5769	D, S, Mid	\$ 1745	\$ 1807	\$ 1868
72"W	G5772	D, S, Mid	\$ 1790	\$ 1854	\$ 1917
75"W	G5775	D, S, Mid	\$ 1899	\$ 1966	\$ 2033
78"W	G5778	D, S, Mid	\$ 2069	\$ 2143	\$ 2216
81"W	G5781	D, S, Mid	\$ 2235	\$ 2315	\$ 2393
84"W	G5784	D, S, Mid	\$ 2373	\$ 2457	\$ 2541

Note: Configuration is not included in model number

- Mid** Mid Panel
- S** End Single Sided
- D** End Dual Sided

<p>How to specify — Select the Model Number from above.</p>	<p>1st Option: FSC: F FSC Wood X Non-FSC Wood</p>	<p>2nd Option: Laminate: See page 132 for finishes.</p>	<p>3rd Option: Edge: See page 132 for finishes.</p>	<p>4th Option: Grain: VLG Horizontal grain or Solid only. VST Vertical Grain (available only for single panels 60" W or less, and for split panels between 87" W and 117" W).</p>	<p>5th Option: Glide:</p>
G 	V .	G

Example: G5718.X.LT11.TI.VLG.G

Gallery Panels

30"H Application for Use with Glass

For Gallery Panel Glass see page 172.
 For Gallery Panel connectors see page 171.

GSA SIN 33721

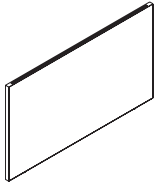

Description	Model	Configuration	List Price			Accepts Glass Models
			L1	L2	L3	7½"H, 13"H, 15"H
30"H Gallery Panels with Glass						
18"W	G3018G	Mid	\$ 724	\$ 751	\$ 776	G4 ☐☐ 15GS
21"W	G3021G	Mid	\$ 742	\$ 769	\$ 796	G4 ☐☐ 18GS
24"W	G3024G	Mid	\$ 775	\$ 803	\$ 831	G4 ☐☐ 21GS
27"W	G3027G	Mid	\$ 812	\$ 841	\$ 870	G4 ☐☐ 24GS
30"W	G3030G	Mid	\$ 894	\$ 926	\$ 958	G4 ☐☐ 27GS
33"W	G3033G	S, Mid	\$ 933	\$ 966	\$ 999	G4 ☐☐ 30GS
36"W	G3036G	S, Mid	\$ 967	\$ 1001	\$ 1037	G4 ☐☐ 33GS
39"W	G3039G	S, Mid	\$ 1027	\$ 1064	\$ 1100	G4 ☐☐ 36GS
42"W	G3042G	S, Mid	\$ 1090	\$ 1130	\$ 1168	G4 ☐☐ 39GS
45"W	G3045G	S, Mid	\$ 1166	\$ 1209	\$ 1249	G4 ☐☐ 42GS
48"W	G3048G	S, Mid	\$ 1211	\$ 1255	\$ 1297	G4 ☐☐ 45GS
51"W	G3051G	D, S, Mid	\$ 1228	\$ 1272	\$ 1315	G4 ☐☐ 48GS
54"W	G3054G	D, S, Mid	\$ 1276	\$ 1322	\$ 1367	G4 ☐☐ 51GS
57"W	G3057G	D, S, Mid	\$ 1321	\$ 1368	\$ 1415	G4 ☐☐ 54GS
60"W	G3060G	D, S, Mid	\$ 1371	\$ 1420	\$ 1468	G4 ☐☐ 57GS
63"W	G3063G	D, S, Mid	\$ 1391	\$ 1441	\$ 1489	G4 ☐☐ 60GS
66"W	G3066G	D, S, Mid	\$ 1416	\$ 1466	\$ 1517	G4 ☐☐ 63GS
69"W	G3069G	D, S, Mid	\$ 1501	\$ 1555	\$ 1608	G4 ☐☐ 66GS
72"W	G3072G	D, S, Mid	\$ 1537	\$ 1592	\$ 1646	G4 ☐☐ 69GS
75"W	G3075G	D, S, Mid	\$ 1708	\$ 1769	\$ 1829	G4 ☐☐ 72GS
78"W	G3078G	D, S, Mid	\$ 1768	\$ 1830	\$ 1893	G4 ☐☐ 75GS
81"W	G3081G	D, S, Mid	\$ 1822	\$ 1887	\$ 1951	G4 ☐☐ 78GS
84"W	G3084G	D, S, Mid	\$ 1975	\$ 2046	\$ 2116	G4 ☐☐ 81GS

Note: Configuration is not included in model number

- Mid** Mid Panel
- S** End Single Sided
- D** End Dual Sided

Note: Fill in model number blanks with one of the following options to determine glass height.

- 07** 7.5"H glass
- 13** 13"H glass
- 15** 15"H glass

<p>How to specify — Select the Model Number from above.</p>	<p>1st Option: FSC: F FSC Wood X Non-FSC Wood</p>	<p>2nd Option: Laminate: See page 132 for finishes.</p>	<p>3rd Option: Edge: See page 132 for finishes.</p>	<p>4th Option: Grain: VLG Horizontal grain or Solid only. VST Vertical Grain (available only for single panels 60"W or less, and for split panels between 87"W and 117"W).</p>	<p>5th Option: Glide:</p>
G . .				V .	G

Example: G3018G.X.LT11.TI.VLG.G

Gallery Panels

35"H Application for Use with Glass

For Gallery Panel Glass see page 172.
For Gallery Panel connectors see page 171.

GSA SIN 33721

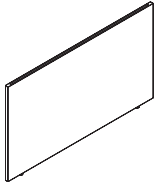

Description	Model	Configuration	List Price			Accepts Glass Models
			L1	L2	L3	7½"H, 13"H, 15"H
35"H Gallery Panels with Glass						
18"W	G3518G	Mid	\$ 814	\$ 844	\$ 873	G4 □□ 15GS
21"W	G3521G	Mid	\$ 834	\$ 865	\$ 895	G4 □□ 18GS
24"W	G3524G	Mid	\$ 871	\$ 903	\$ 935	G4 □□ 21GS
27"W	G3527G	Mid	\$ 906	\$ 939	\$ 972	G4 □□ 24GS
30"W	G3530G	Mid	\$ 1009	\$ 1047	\$ 1083	G4 □□ 27GS
33"W	G3533G	S, Mid	\$ 1051	\$ 1091	\$ 1128	G4 □□ 30GS
36"W	G3536G	S, Mid	\$ 1100	\$ 1142	\$ 1181	G4 □□ 33GS
39"W	G3539G	S, Mid	\$ 1160	\$ 1203	\$ 1244	G4 □□ 36GS
42"W	G3542G	S, Mid	\$ 1199	\$ 1244	\$ 1286	G4 □□ 39GS
45"W	G3545G	S, Mid	\$ 1258	\$ 1305	\$ 1350	G4 □□ 42GS
48"W	G3548G	S, Mid	\$ 1299	\$ 1347	\$ 1393	G4 □□ 45GS
51"W	G3551G	D, S, Mid	\$ 1335	\$ 1384	\$ 1432	G4 □□ 48GS
54"W	G3554G	D, S, Mid	\$ 1380	\$ 1430	\$ 1479	G4 □□ 51GS
57"W	G3557G	D, S, Mid	\$ 1416	\$ 1469	\$ 1519	G4 □□ 54GS
60"W	G3560G	D, S, Mid	\$ 1466	\$ 1520	\$ 1573	G4 □□ 57GS
63"W	G3563G	D, S, Mid	\$ 1492	\$ 1547	\$ 1601	G4 □□ 60GS
66"W	G3566G	D, S, Mid	\$ 1528	\$ 1584	\$ 1639	G4 □□ 63GS
69"W	G3569G	D, S, Mid	\$ 1585	\$ 1643	\$ 1700	G4 □□ 66GS
72"W	G3572G	D, S, Mid	\$ 1642	\$ 1702	\$ 1761	G4 □□ 69GS
75"W	G3575G	D, S, Mid	\$ 1753	\$ 1817	\$ 1880	G4 □□ 72GS
78"W	G3578G	D, S, Mid	\$ 1831	\$ 1898	\$ 1963	G4 □□ 75GS
81"W	G3581G	D, S, Mid	\$ 1960	\$ 2032	\$ 2102	G4 □□ 78GS
84"W	G3584G	D, S, Mid	\$ 2123	\$ 2201	\$ 2277	G4 □□ 81GS

Note: Configuration is not included in model number

- Mid** Mid Panel
- S** End Single Sided
- D** End Dual Sided

Note: Fill in model number blanks with one of the following options to determine glass height.

- 07** 7.5"H glass
- 13** 13"H glass
- 15** 15"H glass

How to specify — Select the Model Number from above.	1st Option: FSC: F FSC Wood X Non-FSC Wood	2nd Option: Laminate: See page 132 for finishes.	3rd Option: Edge: See page 132 for finishes.	4th Option: Grain: VLG Horizontal grain or Solid only. VST Vertical Grain (available only for single panels 60"W or less, and for split panels between 87"W and 117"W).	5th Option: Glide:
G 	V .	G .

Example: G3518G.X.LT11.TI.VLG.G

Gallery Panels

42"H Application for Use with Glass

For Gallery Panel Glass see page 172.
For Gallery Panel connectors see page 171.

GSA SIN 33721

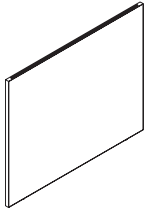

Description	Model	Configuration	List Price			Accepts Glass Models
			L1	L2	L3	7½"H, 13"H, 15"H
42"H Gallery Panels with Glass						
18"W	G4218G	Mid	\$ 887	\$ 919	\$ 951	G4 □□ 15GS
21"W	G4221G	Mid	\$ 903	\$ 935	\$ 968	G4 □□ 18GS
24"W	G4224G	Mid	\$ 949	\$ 983	\$ 1017	G4 □□ 21GS
27"W	G4227G	Mid	\$ 991	\$ 1027	\$ 1062	G4 □□ 24GS
30"W	G4230G	Mid	\$ 1105	\$ 1146	\$ 1184	G4 □□ 27GS
33"W	G4233G	S, Mid	\$ 1151	\$ 1193	\$ 1233	G4 □□ 30GS
36"W	G4236G	S, Mid	\$ 1204	\$ 1248	\$ 1289	G4 □□ 33GS
39"W	G4239G	S, Mid	\$ 1273	\$ 1319	\$ 1364	G4 □□ 36GS
42"W	G4242G	S, Mid	\$ 1318	\$ 1365	\$ 1411	G4 □□ 39GS
45"W	G4245G	S, Mid	\$ 1355	\$ 1403	\$ 1451	G4 □□ 42GS
48"W	G4248G	S, Mid	\$ 1400	\$ 1450	\$ 1499	G4 □□ 45GS
51"W	G4251G	D, S, Mid	\$ 1472	\$ 1525	\$ 1577	G4 □□ 48GS
54"W	G4254G	D, S, Mid	\$ 1510	\$ 1564	\$ 1618	G4 □□ 51GS
57"W	G4257G	D, S, Mid	\$ 1544	\$ 1599	\$ 1654	G4 □□ 54GS
60"W	G4260G	D, S, Mid	\$ 1590	\$ 1647	\$ 1703	G4 □□ 57GS
63"W	G4263G	D, S, Mid	\$ 1626	\$ 1684	\$ 1742	G4 □□ 60GS
66"W	G4266G	D, S, Mid	\$ 1671	\$ 1730	\$ 1790	G4 □□ 63GS
69"W	G4269G	D, S, Mid	\$ 1700	\$ 1760	\$ 1820	G4 □□ 66GS
72"W	G4272G	D, S, Mid	\$ 1782	\$ 1846	\$ 1909	G4 □□ 69GS
75"W	G4275G	D, S, Mid	\$ 1836	\$ 1902	\$ 1966	G4 □□ 72GS
78"W	G4278G	D, S, Mid	\$ 1936	\$ 2006	\$ 2072	G4 □□ 75GS
81"W	G4281G	D, S, Mid	\$ 2136	\$ 2213	\$ 2288	G4 □□ 78GS
84"W	G4284G	D, S, Mid	\$ 2281	\$ 2362	\$ 2442	G4 □□ 81GS

Note: Configuration is not included in model number

- Mid** Mid Panel
- S** End Single Sided
- D** End Dual Sided

Note: Fill in model number blanks with one of the following options to determine glass height.

- 07** 7.5"H glass
- 13** 13"H glass
- 15** 15"H glass

How to specify — Select the Model Number from above.	1st Option: FSC: F FSC Wood X Non-FSC Wood	2nd Option: Laminate: See page 132 for finishes.	3rd Option: Edge: See page 132 for finishes.	4th Option: Grain: VLG Horizontal grain or Solid only. VST Vertical Grain (available only for single panels 60"W or less, and for split panels between 87"W and 117"W.	5th Option: Glide: G
G 	V .	G

Example: G4218G.X.LT11.TI.VLG.G

Gallery Panels

50"H Application for Use with Glass

For Gallery Panel Glass see page 172.
For Gallery Panel connectors see page 171.

GSA SIN 33721

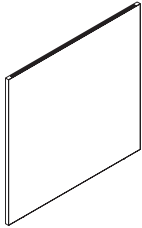

Description	Model	Configuration	List Price			Accepts Glass Models
			L1	L2	L3	7½"H, 13"H, 15"H
50"H Gallery Panels with Glass						
18"W	G5018G	Mid	\$ 997	\$ 1033	\$ 1068	G4 □□ 15GS
21"W	G5021G	Mid	\$ 1018	\$ 1055	\$ 1091	G4 □□ 18GS
24"W	G5024G	Mid	\$ 1056	\$ 1094	\$ 1131	G4 □□ 21GS
27"W	G5027G	Mid	\$ 1102	\$ 1142	\$ 1181	G4 □□ 24GS
30"W	G5030G	Mid	\$ 1199	\$ 1243	\$ 1284	G4 □□ 27GS
33"W	G5033G	S, Mid	\$ 1249	\$ 1294	\$ 1338	G4 □□ 30GS
36"W	G5036G	S, Mid	\$ 1298	\$ 1345	\$ 1390	G4 □□ 33GS
39"W	G5039G	S, Mid	\$ 1364	\$ 1413	\$ 1460	G4 □□ 36GS
42"W	G5042G	S, Mid	\$ 1426	\$ 1478	\$ 1527	G4 □□ 39GS
45"W	G5045G	S, Mid	\$ 1510	\$ 1564	\$ 1618	G4 □□ 42GS
48"W	G5048G	S, Mid	\$ 1544	\$ 1599	\$ 1654	G4 □□ 45GS
51"W	G5051G	D, S, Mid	\$ 1577	\$ 1633	\$ 1689	G4 □□ 48GS
54"W	G5054G	D, S, Mid	\$ 1631	\$ 1689	\$ 1747	G4 □□ 51GS
57"W	G5057G	D, S, Mid	\$ 1668	\$ 1727	\$ 1786	G4 □□ 54GS
60"W	G5060G	D, S, Mid	\$ 1710	\$ 1771	\$ 1831	G4 □□ 57GS
63"W	G5063G	D, S, Mid	\$ 1742	\$ 1804	\$ 1865	G4 □□ 60GS
66"W	G5066G	D, S, Mid	\$ 1785	\$ 1849	\$ 1912	G4 □□ 63GS
69"W	G5069G	D, S, Mid	\$ 1829	\$ 1894	\$ 1958	G4 □□ 66GS
72"W	G5072G	D, S, Mid	\$ 1872	\$ 1939	\$ 2004	G4 □□ 69GS
75"W	G5075G	D, S, Mid	\$ 1980	\$ 2051	\$ 2121	G4 □□ 72GS
78"W	G5078G	D, S, Mid	\$ 2151	\$ 2228	\$ 2304	G4 □□ 75GS
81"W	G5081G	D, S, Mid	\$ 2316	\$ 2398	\$ 2480	G4 □□ 78GS
84"W	G5084G	D, S, Mid	\$ 2456	\$ 2543	\$ 2630	G4 □□ 81GS

Note: Configuration is not included in model number

- Mid Mid Panel
- S End Single Sided
- D End Dual Sided

Note: Fill in model number blanks with one of the following options to determine glass height.

- 07 7.5"H glass
- 13 13"H glass
- 15 15"H glass

<p>How to specify — Select the Model Number from above.</p>	<p>1st Option: FSC: F FSC Wood X Non-FSC Wood</p>	<p>2nd Option: Laminate: See page 132 for finishes.</p>	<p>3rd Option: Edge: See page 132 for finishes.</p>	<p>4th Option: Grain: VLG Horizontal grain or Solid only. VST Vertical Grain (available only for single panels 60"W or less, and for split panels between 87"W and 117"W).</p>	<p>5th Option: Glide:</p>
G . .				V .	G .

Example: G5018G.X.LT11.TI.VLG.G

Gallery Panels

57½"H Application for Use with Glass

For Gallery Panel Glass see page 172.
 For Gallery Panel connectors see page 171.

GSA SIN 33721

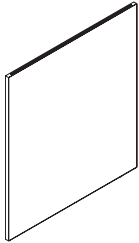

Description	Model	Configuration	List Price			Accepts Glass Models 7½"H, 13"H, 15"H
			L1	L2	L3	
57½"H Gallery Panels with Glass						
18"W	G5718G	Mid	\$ 1161	\$ 1203	\$ 1244	G4 □□ 15GS
21"W	G5721G	Mid	\$ 1183	\$ 1226	\$ 1267	G4 □□ 18GS
24"W	G5724G	Mid	\$ 1220	\$ 1264	\$ 1306	G4 □□ 21GS
27"W	G5727G	Mid	\$ 1262	\$ 1308	\$ 1352	G4 □□ 24GS
30"W	G5730G	Mid	\$ 1363	\$ 1412	\$ 1459	G4 □□ 27GS
33"W	G5733G	S, Mid	\$ 1411	\$ 1461	\$ 1510	G4 □□ 30GS
36"W	G5736G	S, Mid	\$ 1464	\$ 1517	\$ 1569	G4 □□ 33GS
39"W	G5739G	S, Mid	\$ 1527	\$ 1582	\$ 1636	G4 □□ 36GS
42"W	G5742G	S, Mid	\$ 1589	\$ 1646	\$ 1701	G4 □□ 39GS
45"W	G5745G	S, Mid	\$ 1673	\$ 1732	\$ 1792	G4 □□ 42GS
48"W	G5748G	S, Mid	\$ 1706	\$ 1766	\$ 1827	G4 □□ 45GS
51"W	G5751G	D, S, Mid	\$ 1740	\$ 1801	\$ 1863	G4 □□ 48GS
54"W	G5754G	D, S, Mid	\$ 1795	\$ 1859	\$ 1922	G4 □□ 51GS
57"W	G5757G	D, S, Mid	\$ 1831	\$ 1896	\$ 1961	G4 □□ 54GS
60"W	G5760G	D, S, Mid	\$ 1873	\$ 1940	\$ 2005	G4 □□ 57GS
63"W	G5763G	D, S, Mid	\$ 1906	\$ 1974	\$ 2040	G4 □□ 60GS
66"W	G5766G	D, S, Mid	\$ 1946	\$ 2016	\$ 2083	G4 □□ 63GS
69"W	G5769G	D, S, Mid	\$ 1991	\$ 2062	\$ 2133	G4 □□ 66GS
72"W	G5772G	D, S, Mid	\$ 2036	\$ 2109	\$ 2180	G4 □□ 69GS
75"W	G5775G	D, S, Mid	\$ 2142	\$ 2219	\$ 2294	G4 □□ 72GS
78"W	G5778G	D, S, Mid	\$ 2316	\$ 2398	\$ 2480	G4 □□ 75GS
81"W	G5781G	D, S, Mid	\$ 2478	\$ 2567	\$ 2653	G4 □□ 78GS
84"W	G5784G	D, S, Mid	\$ 2621	\$ 2714	\$ 2806	G4 □□ 81GS

Note: Configuration is not included in model number
Mid Mid Panel
S End Single Sided
D End Dual Sided

Note: Fill in model number blanks with one of the following options to determine glass height.
07 7.5"H glass
13 13"H glass
15 15"H glass

<p>How to specify — Select the Model Number from above.</p>	<p>1st Option: FSC: F FSC Wood X Non-FSC Wood</p>	<p>2nd Option: Laminate: See page 132 for finishes.</p>	<p>3rd Option: Edge: See page 132 for finishes.</p>	<p>4th Option: Grain: VLG Horizontal grain or Solid only. VST Vertical Grain (available only for single panels 60"W or less, and for split panels between 87"W and 117"W).</p>	<p>5th Option: Glide:</p>
<p>G . .</p>				<p>V .</p>	<p>G .</p>

Example: G5718G.X.LTI1.TI.VLG.G

GSA SIN PENDING

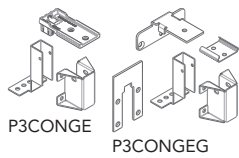

Description	Model	List Price		
		P1	P2	P3
Optimize Connector Kit				
End Panel Connector Kit for Optimize System	P3CONGE	\$ 164	\$ 172	\$ 179
Glass End Panel connector kit for Optimize System	P3CONGEG	\$ 332	\$ 347	\$ 361

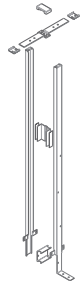

Optimize Single-Sided Mid-Connector				
35" Single-Sided Mid	P3CONGM35S	\$ 290	\$ 303	\$ 315
42" Single-Sided Mid	P3CONGM42S	\$ 290	\$ 303	\$ 315
50" Single-Sided Mid	P3CONGM50S	\$ 332	\$ 347	\$ 361
57.5" Single-Sided Mid	P3CONGM57S	\$ 332	\$ 347	\$ 361
65" Single-Sided Mid	P3CONGM65S	\$ 389	\$ 407	\$ 422
72" Single-Sided Mid	P3CONGM72S	\$ 389	\$ 407	\$ 422

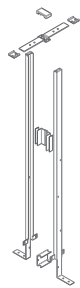

Optimize Dual-Sided Mid-Connector				
35" Dual-Sided Mid	P3CONGM35D	\$ 290	\$ 303	\$ 315
42" Dual-Sided Mid	P3CONGM42D	\$ 290	\$ 303	\$ 315
50" Dual-Sided Mid	P3CONGM50D	\$ 332	\$ 347	\$ 361
57.5" Dual-Sided Mid	P3CONGM57D	\$ 332	\$ 347	\$ 361
65" Dual-Sided Mid	P3CONGM65D	\$ 389	\$ 407	\$ 422
72" Dual-Sided Mid	P3CONGM72D	\$ 389	\$ 407	\$ 422

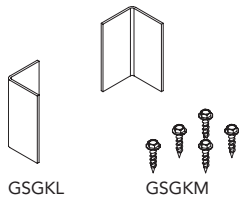

Storage Mounting Brackets				
Gallery Laminate Storage Ganging Kit	GSGKL	\$ 80	N/A	N/A
Gallery Metal Storage Ganging Kit	GSGKM	\$ 19	N/A	N/A

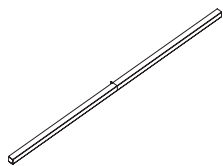

Gallery Panel Stiffener				
Stiffener for 75"W/78"W Panels	GSTFN7578	\$ 181	\$ 196	\$ 215
Stiffener for 81"W/84"W Panels	GSTFN8184	\$ 202	\$ 219	\$ 242
Approved under GSA SIN 33721				

<p>How to specify — Select the Model Number from above.</p>	<p><i>1st Option:</i> Paint for Connector Kits and Brackets (if available): P1 P2 P3 See page 132 for finishes.</p>
--	--

Examples: P3CONGM35S.P71 GSGKL GSGKM

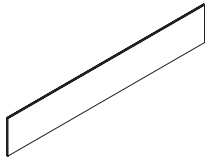

Description	Model	List Price		
		Clear Glass	Frosted Glass	Smoked Glass
7½"H Gallery Glass — Single Panel				
15"W	G40715GS	\$ 212	\$ 233	\$ 240
18"W	G40718GS	\$ 218	\$ 240	\$ 247
21"W	G40721GS	\$ 222	\$ 244	\$ 252
24"W	G40724GS	\$ 226	\$ 249	\$ 256
27"W	G40727GS	\$ 246	\$ 270	\$ 278
30"W	G40730GS	\$ 263	\$ 290	\$ 297
33"W	G40733GS	\$ 289	\$ 318	\$ 327
36"W	G40736GS	\$ 325	\$ 357	\$ 368
39"W	G40739GS	\$ 352	\$ 386	\$ 399
42"W	G40742GS	\$ 394	\$ 434	\$ 446
45"W	G40745GS	\$ 428	\$ 471	\$ 484
48"W	G40748GS	\$ 465	\$ 511	\$ 525
51"W	G40751GS	\$ 475	\$ 522	\$ 537
54"W	G40754GS	\$ 514	\$ 564	\$ 581
57"W	G40757GS	\$ 569	\$ 625	\$ 643
60"W	G40760GS	\$ 667	\$ 732	\$ 754
63"W	G40763GS	\$ 776	\$ 853	\$ 877
66"W	G40766GS	\$ 839	\$ 921	\$ 948
69"W	G40769GS	\$ 918	\$ 1008	\$ 1037
72"W	G40772GS	\$ 982	\$ 1078	\$ 1110
75"W	G40775GS	\$ 1050	\$ 1152	\$ 1186
78"W	G40778GS	\$ 1156	\$ 1268	\$ 1306
81"W	G40781GS	\$ 1215	\$ 1334	\$ 1372

How to specify —
Select the Model Number from above.

1st Option:

Glass:

- LC Clear Glass
- LF Frosted Glass
- GSM1 Smoked Glass

G 4 0 7 | | | | | .

| | | | | .

Example: G40715GS.LC

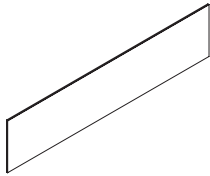

Description	Model	List Price		
		Clear Glass	Frosted Glass	Smoked Glass
13"H Gallery Glass — Single Panel				
24"W	G41324GS	\$ 515	\$ 572	\$ 590
27"W	G41327GS	\$ 562	\$ 623	\$ 644
30"W	G41330GS	\$ 604	\$ 670	\$ 691
33"W	G41333GS	\$ 635	\$ 705	\$ 728
36"W	G41336GS	\$ 673	\$ 747	\$ 770
39"W	G41339GS	\$ 726	\$ 806	\$ 832
42"W	G41342GS	\$ 750	\$ 832	\$ 859
45"W	G41345GS	\$ 766	\$ 850	\$ 877
48"W	G41348GS	\$ 791	\$ 877	\$ 906
51"W	G41351GS	\$ 804	\$ 891	\$ 921
54"W	G41354GS	\$ 861	\$ 955	\$ 985
57"W	G41357GS	\$ 880	\$ 976	\$ 1008
60"W	G41360GS	\$ 905	\$ 1003	\$ 1036
63"W	G41363GS	\$ 970	\$ 1076	\$ 1111
66"W	G41366GS	\$ 1052	\$ 1167	\$ 1205
69"W	G41369GS	\$ 1113	\$ 1234	\$ 1274
72"W	G41372GS	\$ 1193	\$ 1323	\$ 1366
75"W	G41375GS	\$ 1281	\$ 1421	\$ 1466
78"W	G41378GS	\$ 1363	\$ 1511	\$ 1560
81"W	G41381GS	\$ 1438	\$ 1594	\$ 1646

<p><i>How to specify —</i> Select the Model Number from above.</p>	<p><i>1st Option:</i> Glass: LC Clear Glass LF Frosted Glass GSM1 Smoked Glass</p>
--	---

G 4 1 3 | | | | | . | | | | | .

Example: G41324GS.LC

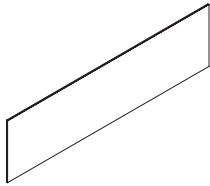

Description	Model	List Price		
		Clear Glass	Frosted Glass	Smoked Glass
15"H Gallery Glass — Single Panel				
15"W	G41515GS	\$ 538	\$ 597	\$ 617
18"W	G41518GS	\$ 562	\$ 623	\$ 644
21"W	G41521GS	\$ 588	\$ 653	\$ 673
24"W	G41524GS	\$ 618	\$ 685	\$ 708
27"W	G41527GS	\$ 638	\$ 708	\$ 731
30"W	G41530GS	\$ 664	\$ 737	\$ 760
33"W	G41533GS	\$ 697	\$ 774	\$ 798
36"W	G41536GS	\$ 759	\$ 842	\$ 869
39"W	G41539GS	\$ 794	\$ 880	\$ 910
42"W	G41542GS	\$ 814	\$ 903	\$ 932
45"W	G41545GS	\$ 828	\$ 919	\$ 948
48"W	G41548GS	\$ 848	\$ 941	\$ 971
51"W	G41551GS	\$ 867	\$ 961	\$ 992
54"W	G41554GS	\$ 922	\$ 1023	\$ 1055
57"W	G41557GS	\$ 935	\$ 1037	\$ 1070
60"W	G41560GS	\$ 943	\$ 1046	\$ 1079
63"W	G41563GS	\$ 1000	\$ 1109	\$ 1145
66"W	G41566GS	\$ 1083	\$ 1201	\$ 1240
69"W	G41569GS	\$ 1139	\$ 1263	\$ 1304
72"W	G41572GS	\$ 1218	\$ 1350	\$ 1395
75"W	G41575GS	\$ 1315	\$ 1458	\$ 1506
78"W	G41578GS	\$ 1386	\$ 1536	\$ 1585
81"W	G41581GS	\$ 1467	\$ 1626	\$ 1679

How to specify —
Select the Model Number from above.

1st Option:

Glass:

- LC Clear Glass
- LF Frosted Glass
- GSM1 Smoked Glass

G 4 1 5 | | | | | .

| | | | | .

Example: G41515GS.LC

GSA SIN Pending

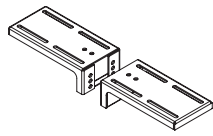

GCTKS

Description	Model	P1 List Price	P2 List Price	P3 List Price
Countertop Bracket				
Countertop Connector Bracket	GCTKS	\$ 121	\$ 128	\$ 132

Note: 2 brackets needed for straight countertops, 3 brackets are needed for corner countertops

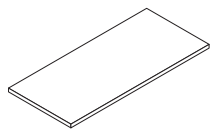

Description	Laminate w/Flat Edge Model	Laminate w/Flat Edge		
		L1 List Price	L2 List Price	L3 List Price
Straight Countertops — must order 2 sets of brackets per surface				
24"W x 15"D	851524M	\$ 387	\$ 405	\$ 418
30"W x 15"D	851530M	\$ 429	\$ 448	\$ 462
36"W x 15"D	851536M	\$ 482	\$ 502	\$ 519
42"W x 15"D	851542M	\$ 499	\$ 519	\$ 537
48"W x 15"D	851548M	\$ 528	\$ 549	\$ 568
54"W x 15"D	851554M	\$ 598	\$ 621	\$ 641
60"W x 15"D	851560M	\$ 667	\$ 687	\$ 704
66"W x 15"D	851566M	\$ 691	\$ 720	\$ 739
72"W x 15"D	851572M	\$ 718	\$ 748	\$ 767



Corner Countertops 15"D at ends — must order 3 sets of brackets per surface				
24"W x 24"W	852424M	\$ 754	\$ 785	\$ 806
30"W x 30"W	853030M	\$ 877	\$ 911	\$ 936
36"W x 36"W	853636M	\$ 973	\$ 1010	\$ 1039
42"W x 42"W	854242M	\$ 1056	\$ 1096	\$ 1129



Flat Edge

Description	Model	P1 List Price	P2 List Price	P3 List Price
Gallery Panel Wall Start				
30"H Wall Start	GWS30	\$ 124	\$ 131	\$ 135
35"H Wall Start	GWS35	\$ 142	\$ 149	\$ 155
42"H Wall Start	GWS42	\$ 154	\$ 162	\$ 167
50"H Wall Start	GWS50	\$ 177	\$ 186	\$ 193
57½"H Wall Start	GWS57	\$ 190	\$ 199	\$ 207

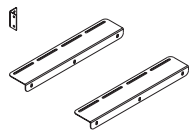

Worksurface Mounting Bracket Kit				
Worksurface Mounting Bracket	GWSBK	\$ 80		

Note: Ships with 2 brackets.

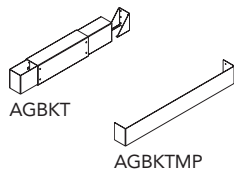

HAT Bracket				
HAT to Fit Panel Bracket T-Leg	AGBKT (shown)	\$ 258	\$ 280	\$ 308
HAT to Fit Panel Bracket C-Leg	AGBK	\$ 258	\$ 280	\$ 308
HAT to Fit Panel Installation Template (Black only, code P)	AGBKTMP (shown)	\$ 63		

How to specify —

Select the Model Number from above.

1st Option:

Paint:

P1 P2 P3

See page 132 for finishes.

Examples:

GSA SIN Pending

Description	Model	P1 List Price	P2 List Price	P3 List Price
Tackboards				
Tackboard 15"H x 24"W	GTB1524	\$ 351	\$ 367	\$ 381
Tackboard 15"H x 30"W	GTB1530	\$ 382	\$ 399	\$ 414
Tackboard 15"H x 36"W	GTB1536	\$ 423	\$ 442	\$ 460
Tackboard 15"H x 42"W	GTB1542	\$ 440	\$ 459	\$ 478
Tackboard 15"H x 48"W	GTB1548	\$ 450	\$ 470	\$ 490
Tackboard 15"H x 54"W	GTB1554	\$ 471	\$ 492	\$ 512
Tackboard 15"H x 60"W	GTB1560	\$ 478	\$ 499	\$ 520
Tackboard 22.5"H x 24"W	GTB2224	\$ 395	\$ 413	\$ 428
Tackboard 22.5"H x 30"W	GTB2230	\$ 429	\$ 448	\$ 466
Tackboard 22.5"H x 36"W	GTB2236 (shown)	\$ 468	\$ 488	\$ 509
Tackboard 22.5"H x 42"W	GTB2242	\$ 478	\$ 499	\$ 520
Tackboard 22.5"H x 48"W	GTB2248	\$ 515	\$ 537	\$ 559
Tackboard 22.5"H x 54"W	GTB2254	\$ 541	\$ 564	\$ 587
Tackboard 22.5"H x 60"W	GTB2260	\$ 556	\$ 580	\$ 604

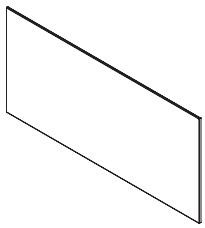

Magnet/Marker Boards				
Magnet/Marker Board 15"H x 24"W	GMB1524	\$ 464	\$ 484	\$ 505
Magnet/Marker Board 15"H x 30"W	GMB1530	\$ 501	\$ 523	\$ 544
Magnet/Marker Board 15"H x 36"W	GMB1536	\$ 533	\$ 556	\$ 579
Magnet/Marker Board 15"H x 42"W	GMB1542	\$ 560	\$ 584	\$ 608
Magnet/Marker Board 15"H x 48"W	GMB1548	\$ 587	\$ 612	\$ 637
Magnet/Marker Board 15"H x 54"W	GMB1554	\$ 604	\$ 631	\$ 656
Magnet/Marker Board 15"H x 60"W	GMB1560	\$ 638	\$ 666	\$ 693
Magnet/Marker Board 22.5"H x 24"W	GMB2224	\$ 572	\$ 596	\$ 621
Magnet/Marker Board 22.5"H x 30"W	GMB2230	\$ 601	\$ 626	\$ 653
Magnet/Marker Board 22.5"H x 36"W	GMB2236	\$ 626	\$ 653	\$ 680
Magnet/Marker Board 22.5"H x 42"W	GMB2242	\$ 656	\$ 684	\$ 712
Magnet/Marker Board 22.5"H x 48"W	GMB2248 (shown)	\$ 688	\$ 718	\$ 746
Magnet/Marker Board 22.5"H x 54"W	GMB2254	\$ 709	\$ 739	\$ 769
Magnet/Marker Board 22.5"H x 60"W	GMB2260	\$ 734	\$ 765	\$ 796

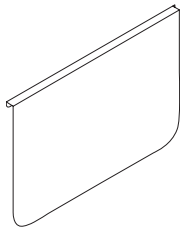

Hanging Magnet/Marker Boards & Blotter				
Hanging Magnet/Marker Board or Blotter 20"H x 30"W	GHMB2030 (shown)	\$ 365	\$ 382	\$ 396
Hanging Magnet/Marker Board or Blotter 26"H x 30"W	GHMB2630	\$ 507	\$ 529	\$ 551

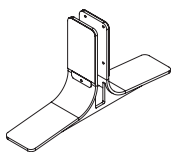

Gallery Panel Foot				
Gallery Panel Foot (Single)	GFT1	\$ 347	\$ 363	\$ 377
Gallery Panel Foot (Dual)	GFT2	\$ 694	\$ 724	\$ 753

Note: Available in textured paint only

How to specify —
Select the Model Number from above.

1st Option:
Paint:
P1 P2 P3
See page 132 for finishes.

2nd Option:
Fabric
(if applicable):
See page 133 for fabrics.

Examples:
G | | | | | | | | | . P1 | P2 | P3 | | | | . | | | | | | | | | .

GSA SIN Pending

Description	Model	L1 List Price	L2 List Price	L3 List Price
Laminate Floating Shelves				
12"W Floating Shelf	GSTF12	\$ 271	\$ 283	\$ 294
18"W Floating Shelf	GSTF18	\$ 302	\$ 315	\$ 329
24"W Floating Shelf	GSTF24	\$ 332	\$ 347	\$ 361
30"W Floating Shelf	GSTF30	\$ 362	\$ 379	\$ 393
36"W Floating Shelf	GSTF36	\$ 393	\$ 411	\$ 426
42"W Floating Shelf	GSTF42	\$ 423	\$ 442	\$ 460
48"W Floating Shelf	GSTF48	\$ 453	\$ 473	\$ 493
54"W Floating Stiffener Shelf	GSTF54	\$ 483	\$ 504	\$ 525
60"W Floating Stiffener Shelf	GSTF60	\$ 513	\$ 535	\$ 557
66"W Floating Stiffener Shelf	GSTF66 (shown)	\$ 543	\$ 566	\$ 590
72"W Floating Stiffener Shelf	GSTF72	\$ 572	\$ 596	\$ 621
78"W Floating Stiffener Shelf	GSTF78	\$ 604	\$ 631	\$ 656

Accessory Rail & Paper Management				
Gallery Panel 12"W Accessory Rail	GACRL12 (shown)	\$ 238	\$ 249	\$ 259
Gallery Panel 18"W Accessory Rail	GACRL18	\$ 255	\$ 267	\$ 277
Gallery Panel 24"W Accessory Rail	GACRL24	\$ 257	\$ 269	\$ 279
Gallery Panel 30"W Accessory Rail	GACRL30	\$ 271	\$ 283	\$ 294
Gallery Panel 36"W Accessory Rail	GACRL36	\$ 286	\$ 299	\$ 310
Triple Angle File	G3AGF	\$ 226	\$ 236	\$ 246
Double Angle File	G2AGF (shown)	\$ 190	\$ 199	\$ 207
Single Angle File	G1AGF	\$ 155	\$ 163	\$ 170
Triple Paper Tray	G3PTR	\$ 226	\$ 236	\$ 246
Double Paper Tray	G2PTR	\$ 190	\$ 199	\$ 207
Single Paper Tray	G1PTR (shown)	\$ 155	\$ 163	\$ 170
Personal Shelf	GWPSF (shown)	\$ 190	\$ 199	\$ 207
Binder Shelf	GBRSF (shown)	\$ 190	\$ 199	\$ 207
Coat Hook Rail-Based	GCHRB (shown)	\$ 77	\$ 82	\$ 85
Coat Hook Mounted	GCHMT	\$ 90	\$ 95	\$ 99

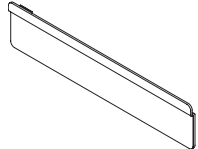
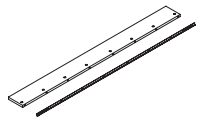

GACRL12

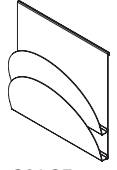

G2AGF

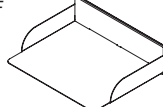

G1PTR

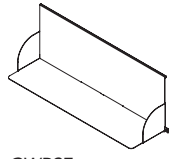

GWPSF

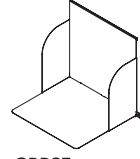

GBRSF

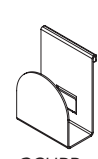

GCHRB

How to specify —
Select the Model Number from above.

1st Option:
Paint:
P1 P2 P3
See page 132 for finishes.

Examples:

_____ . _____

Notes

Finishes 180

Specifications

Introduction and Overview 181

Electrical (8-Wire)

Working with Electrical & Data 182-188

Power Harnesses and Pass-Thru Cables 189

Duplex Receptacles and Infeeds 190

Power Poles and Electrical & Data Components 191-192

Worksurfaces & Supports

Working with Worksurfaces and Supports 193-200

Working with Cadence® Freestanding Desking 201-209

Laminate Flat Edge Worksurfaces,

Primary, Wave, and Bow Front 210-211

Corner, Corner Shelf, and Corner Cove 212-213

Altitude® Height-Adjustable Reference 213

Peninsula, P-Shaped, and Jetty 214

Quarter-Round and D-Shaped 215

Countertops 216

9120 Program for Non-Standard Sizes 217-218

Worksurface Supports

Panel-mount Worksurface Supports and Brackets 219

Cadence Desking Worksurface Supports and Brackets 220

Cadence Desking Modesty Panels and Gussets 221

Universal Modesty Panels and Metal Center Drawers 222

Metal Overheads

Working with Overheads, Shelves, and Hutches 223-227

Overhead Cabinets, Shelves, and Tackboards 228-229

Hutches and Tackboards 230

PAINTED METAL FINISHES

GRADE P1

Black	P27
Brownstone	P7D
Bungalow	P7C
Designer White	PJW
Flint	P02
Fossil	P28
Loft	P7B
Muslin	P4J
Parchment	P93

GRADE P2

Champagne Metallic	PR5
Gunmetal Metallic	PR3
Platinum Metallic	PR2

GRADE P3

Atom	P8S
Bullseye	PJF
Ember	P8P
Ion	P8N
Iris	P8J
Krypton	P8F
Regatta	P8M

NOTE: For Essentials full finish offering please see Storage Price List.

Metallic paints, due to varying reflectance, may appear to have less visual color consistency than other paint finishes, even when L/A/B values are exactly the same. (L/A/B — measurable aspects of color — values are maintained within a specified range, to ensure consistent appearance of paint colors.)

METAL STORAGE PULLS

Black	E4
Matte Silver	EL

ELECTRICAL AND DATA COMPONENTS

Black	E4
Brownstone	EY
Designer White	DW
Flint	E9
Loft	EV
Muslin	EU
Silver	ES

Recommended Coordinate Colors:
 Bungalow use Muslin EU
 Champagne Metallic use Muslin EU
 Cinder use Brownstone EY
 Fossil use Flint E9
 Gunmetal Metallic use Brownstone EY
 Parchment use Muslin EU
 Pebble use Loft EV
 Pewter use Flint E9
 Platinum Metallic use Silver ES
 Salt use Silver ES
 Titanium use Silver ES

LAMINATES

GRADE L1

SOLID COLORS	
Black	P
Brownstone*	LM13
Bungalow*	LM12
Designer White*	LDW1
Flint*	LM16
Fossil Shale*	LEH1
Loft*	LM11
Muslin*	LM15
Titanium*	LTI1

ABSTRACT

Ash	LT3B
Handspun Pearl	LAHP
Handspun Dove	LAHD
Handspun Slate	LAHS
Handspun Chestnut	LAHC
Silver Mesh	LT8D

WOODGRAIN

Belair	LWBA
Bourbon Cherry	H
Field Elm	LWFE
Florence Walnut*	LFW1
Kingswood Walnut*	LK1
Natural Maple*	LWD
NeoWalnut*	LNU1
Pinnacle	PINC
Shaker Cherry*	LW7C

GRADE L2

Beigewood*	LWBE
Fawn Cypress*	LFC1
Lowell Ash*	LLA1
Mangalore Mango*	LMM1
Natural Recon*	LNR1
Phantom Charcoal*	LPC1
Phantom Ecu*	LPE1
Portico Teak*	LPT1
Skyline Walnut*	LSW1

GRADE L3

Natural Walnut*	LWNW
-----------------------	------

* Storage available in these 30 laminates.

EDGE COLORS

Beigewood	DE
Belair	BA
Black	E4
Bourbon Cherry	H
Brownstone	EY
Bungalow	EX
Designer White	DW
Fawn Cypress	FC
Field Elm	FE
Flint	E9
Florence Walnut	FW
Fossil	FH
Kingswood Walnut	KI
Loft	EV
Lowell Ash	DL
Mangalore Mango	MM
Muslin	EU
Natural Maple	DD
Natural Walnut	DN
Natural Recon	NR
NeoWalnut	NU
Parchment	EN
Phantom Charcoal	PC
Phantom Ecu	PE
Pinnacle	PI
Platinum Metallic	EP
Plyband ♦	PL
Portico Teak	DP
Shaker Cherry	DF
Skyline Walnut	SW
Titanium	TI

♦ Edge is limited to flat edge surfaces: rectangle, square, trapezoid, polygon, or round. No curvilinear or combination curve and straight.

METAL GROMMETS

FOR LAMINATE WORKSURFACES

Oval/Square	
Matte Silver	EL

PLASTIC GROMMETS

FOR WORKSURFACES

Black	E4
Brownstone	EY
Bungalow	EX
Designer White	DW
Flint	E9
Fossil	EH
Loft	EV
Muslin	EU
Parchment	EN
Titanium	TI

PLASTIC GROMMETS WITH WOODGRAIN EDGE

If woodgrain edge is specified, the plastic grommet color is predetermined, based on finish selection.

Beigewood, Fawn Cypress, Natural Maple, and Natural Recon	Muslin EU
Kingswood Walnut and NeoWalnut	Brownstone EY
Phantom Charcoal and Skyline Walnut	Flint E9
Phantom Ecu	Loft EV
Portico Teak	Fossil EH
All other woodgrain options	Black E4

LOCKS

Matte Silver	EL
--------------------	----

Note: Refer to individual product pages for upcharges.

Strong, fast, and friendly. Concensys is simple, durable systems furniture that can be delivered in days instead of weeks.

Overview

Concensys delivers exceptional quality at an attractive price. Its durable construction, ease of specification and installation, and quick ship delivery options make it the best in its class. Concensys features thin profile panels, multiple options for finishes and fabrics, and thoughtful, functional details.

Stronger

With quality details rarely seen in comparable products, including welded steel frames, threaded metal inserts on worksurfaces, metal panel connectors, top caps and kick plates, and a lifetime warranty, Concensys is built to last through multiple reconfigurations and extended use. Plus, panels are shipped fully assembled to reduce installation time and costs.

Faster

Standard production lead times average between two and three weeks.

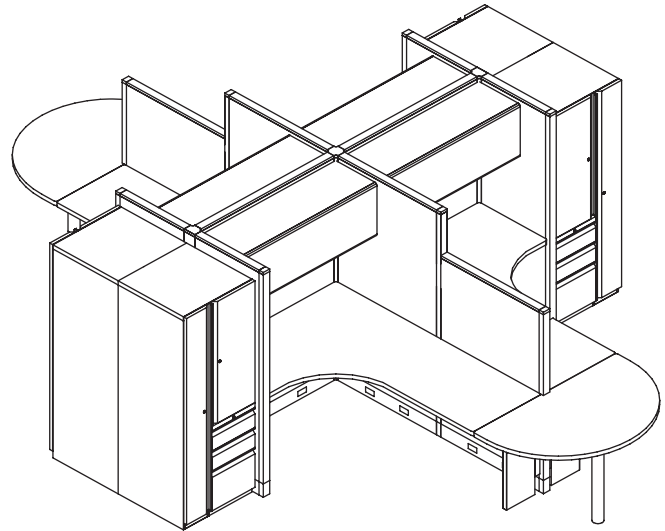

Friendlier

A monolithic, slender panel design simplifies planning, specification and installation by reducing the number of parts and the wasted space of panel creep. Panels are available in seven widths, between 18" and 60", with an enormous range of fabric and finish options to maximize design flexibility.

The Concensys Choice

Backed by Allsteel's Lifetime Warranty and manufactured to strict environmental standards, the Concensys panel system unifies the essential elements of systems furniture in one high-value, best-in-class package. In a complicated world, Concensys is intentionally simple.

It's a quality selection made easy.

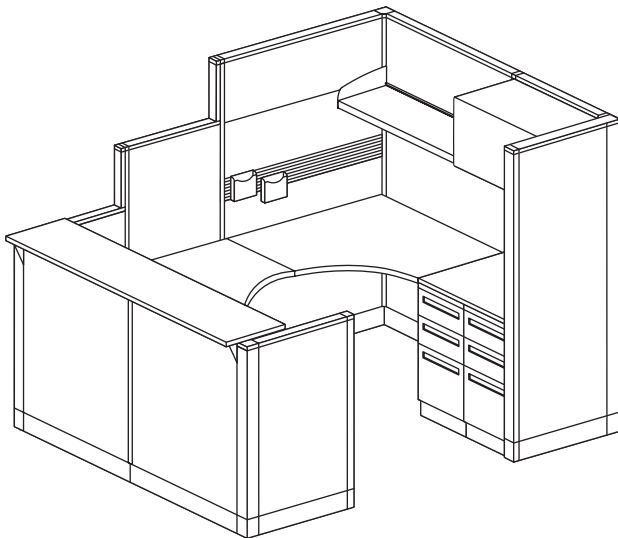

To Order:

1. Determine which electrical system you will use after consulting your electrician and computer support personnel:
 - The four-circuit system (4-Hot/2-Neutral/2-Ground)
 - 3 + 1 option
 - 2 + 2 option
 - The three-circuit system (3-Hot/3-Neutral/2-Ground)
2. Determine location, quantity and circuit of duplexes.
3. Determine the appropriate choice and use of isolated, isolated/dedicated and separate neutrals circuits.
4. Specify appropriate power harnesses* and pass-thru cables.*
5. Determine the location, quantity and type of power infeed needed.

* Select power harness models (A8712XX),

Pass-thru cables (A8710XX) and pass-thru harness (A8711XX) with the last two digits corresponding with the panel width into which the component is to be positioned. The initial cable length can be stretched approximately 3" to transverse "T", "X", "L" and extended straight connectors.

Flexconnect™ Electrical System Options

The four-circuit, eight-wire electrical system is widely specified and trusted by hundreds of thousands of end-users. This proven system delivers four circuits for every power infeed in either a 3 + 1 or 2 + 2 configuration. The isolated/dedicated circuits are ideal for sensitive computing equipment, while the common circuits are suitable for faxes, copiers, task lights and other peripherals. Both the 3 + 1 and 2 + 2 systems use the same pre-wired components, making it easy to adjust as electrical needs change.

You can also choose a three-circuit, eight-wire system that has a dedicated neutral for every hot circuit. The three-circuit components have model numbers with an "A" suffix and appear in a gray box in this pricer.

All three systems utilize an eight-wire electrical system rated at 20 amps per circuit (15 amps Canadian). Concensys panels and electrical components are UL listed and CSA certified.

Reference the Office Equipment Typical Load Values matrix on page 188.

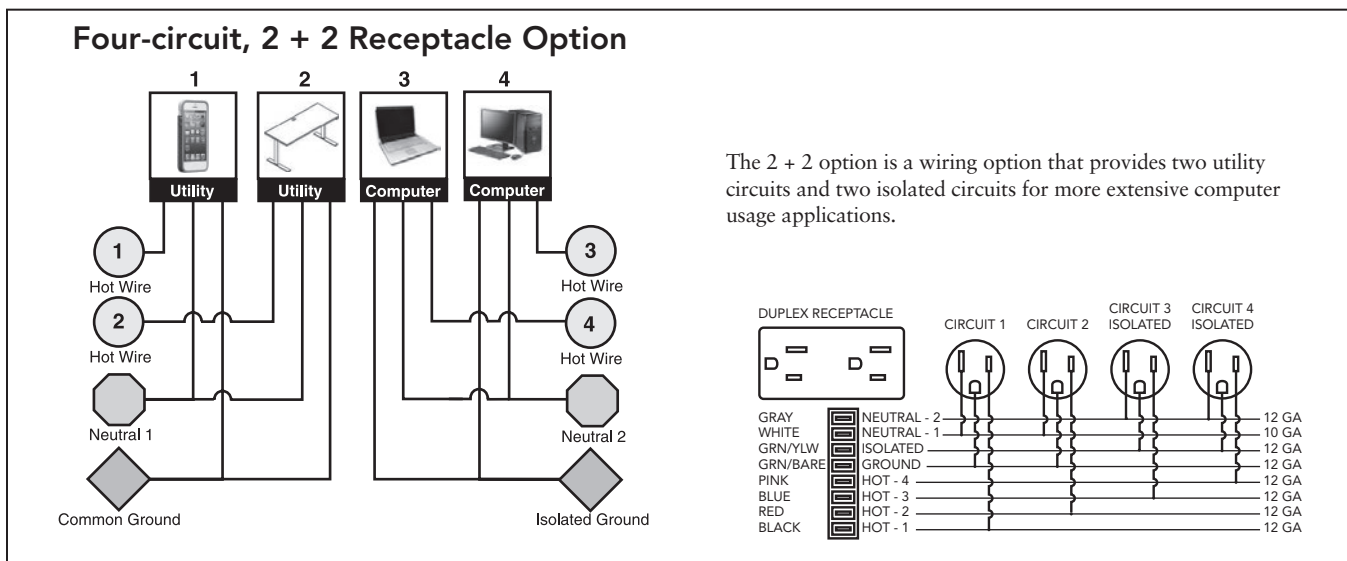
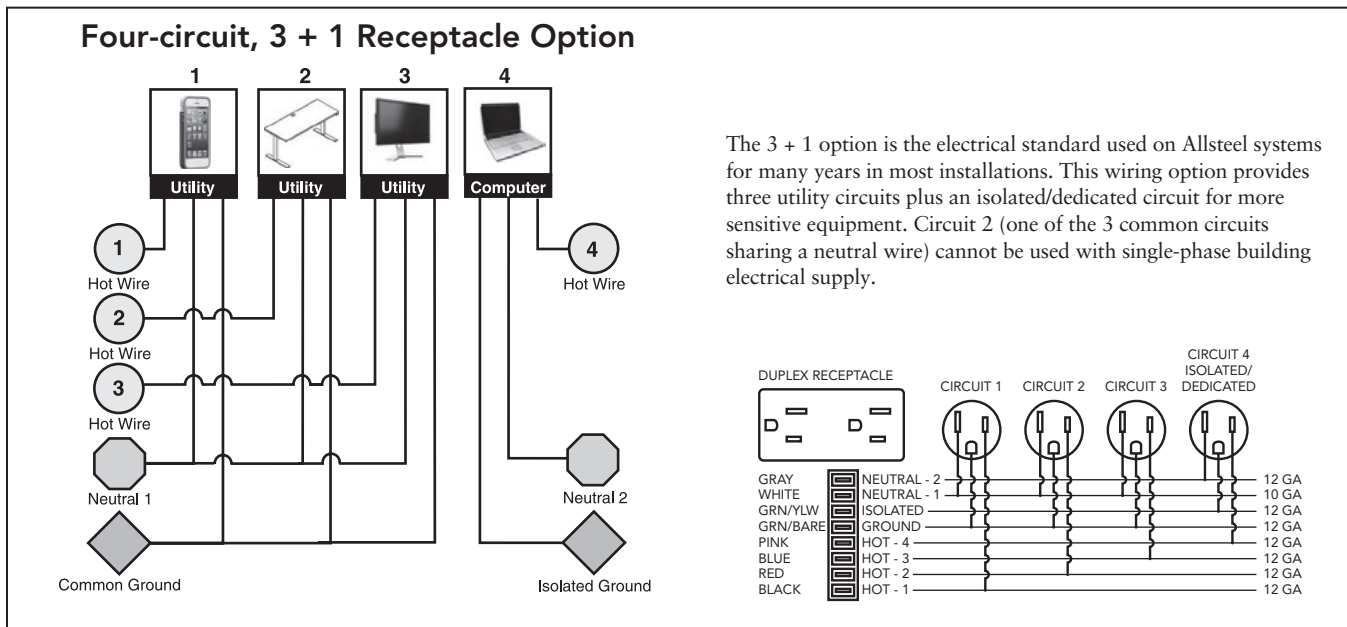

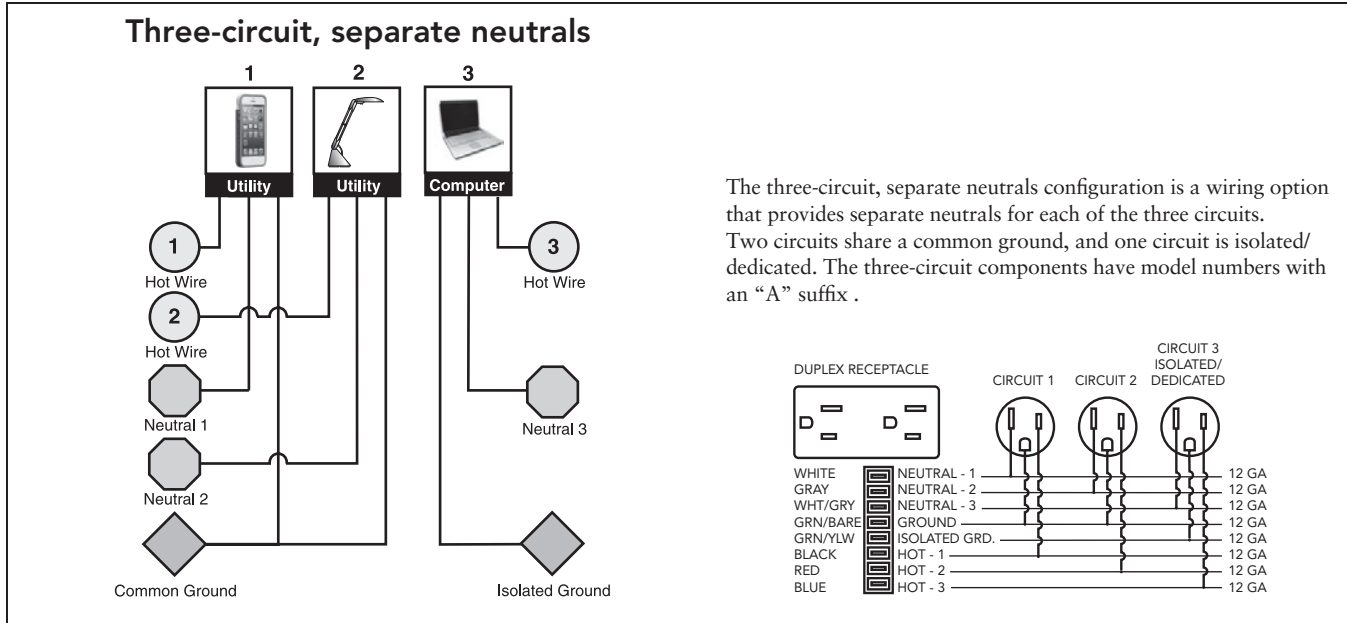

Concensys Receptacle Usage					
Two 8-wire, 20 amp (15 amp Canadian) electrical systems are offered					
Electrical System	Circuitry	Receptacle Capacity			
Four-circuit 4 Hot/2 Neutral/2 Ground	3 + 1	Common Circuit-1 A871501	Common Circuit-2 ⁽¹⁾ A871502	Common Circuit-3 A871503	Iso/Dedicated Circuit-4 A871504
	2 + 2	Common Circuit-1 A871501	Common Circuit-2 A871502	Isolated Circuit-3 A871506	Isolated Circuit-4 A871504
Three-circuit 3 Hot/3 Neutral/2 Ground		Common Circuit-1 A871501A	Common Circuit-2 A871502A	Iso/Dedicated Circuit-3 A871503A	N/A

(1) Circuit-2 (one of the 3 common circuits sharing a neutral wire) cannot be used with a single-phase building electrical supply.

Notes:

- Four-circuit components and three-circuit components (with suffix "A") cannot be used together.
- Components of the two systems are keyed differently to prevent components of one system being connected to components of another system.
- Allsteel model numbers are printed on the UL labels, and components are color-coded to provide visual identification of the different components.
- Four-circuit components have black plastic parts.
- Three-circuit components have rust-colored terminal ends and receptacle backs are rust colored.

Duplex Receptacle



15 amp Receptacle

Concensys Electrical Applications

- Concensys panels are UL 1286 Listed.
- Electrical components are UL Listed and CSA Certified.
- It is the customer's responsibility to ensure that use of the pre-wired electrical system, the number of receptacles used on a given circuit, and connection to a building power source, be in compliance with all local and national electrical codes.

- A licensed electrician must make connections to a building electrical supply.
- To power all panels at a "T" connection, at least one power harness must be used; at a "X", at least two power harnesses must be used.
- Harnesses will stretch up to 3½", to span an extended straight panel connection.
- When multiple 18"W panels are connected at a "T" or "X" connection, an additional 18"W pass-thru cable is required.

- Use power harnesses in all panels adjacent to 18"W panels.
- Pedestals and lateral files, positioned under work surfaces, may render some receptacles inaccessible, and may prohibit use of grommets.
- Four-circuit components and three-circuit components (with suffix "A") cannot be used together.

Definitions of components:

Electrical Power Harness

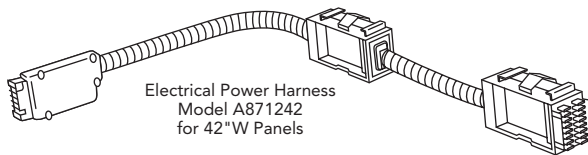

- Used to distribute power in panels 24"W and wider.
- Can be mounted in the base pathway.
- Power distribution in either direction.
- Specify power harness to match panel width.
- Double-sided: receptacles can be inserted into both sides of power blocks.
- Use power harnesses in all panels configured adjacent to 18"W panels (if panel run is to be electrified).

Electrical Pass-Thru Cables

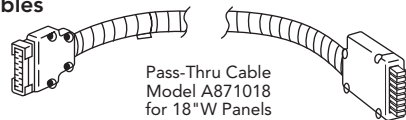

- Pass-Thru Cable Without Duplex Capacity:
- For use in 18"W panels or when no receptacle is required. Specify to panel width.
 - Cable length cannot be stretched.
 - Allows power distribution through panels where receptacles cannot be positioned.
 - When multiple 18"W panels are connected at a "T" or "X" connection, an additional 18"W pass-thru cable is required.

Electrical Pass-Thru Harnesses

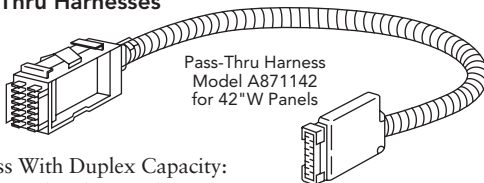

- Pass-Thru Harness With Duplex Capacity:
- For use in 24"W and wider panels.
 - Use in panels where multiple receptacles are not required.
 - Use when specifying both data and electrical at beltline height.
 - Added feature: has capacity for one receptacle on each side of a panel. Feature offers future expansion and is an alternative to power harnesses.

Electrical Jumper Cables

- Jumper cable plugs into power block end of electrical power harness or electrical pass-thru harness.

All electrical power harnesses and pass-thru harnesses will stretch 3½" to span intersections and connections. Jumpers span from beltline to baseline, around corners, and back to beltline.

Duplex Receptacles

- 15-amp outlet configuration.
- Models A871601 and A871601A have a 20-amp outlet configuration required by some large copiers.
- Fit back-to-back into the power block(s) of power and pass-thru harnesses.
- Labeled with the provided circuit. Circuits connected to the Isolated Ground are identified with an orange triangle; circuits that do not share a neutral or ground have an orange circuit number.

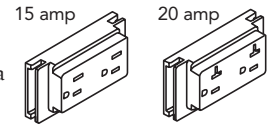

Electrical Infeed Cables, Base/Ceiling Models A879072, A879072A, A879168, and A879168A

- Used to connect the panel electrical system to the building electrical supply Model A879168 or A879168A is used to connect to the building electrical supply, in a ceiling plenum area. Power pole A870070 must be ordered separately.
- A licensed electrician must make connections to a building electrical supply.
- Plugs into any receptacle position; can be rotated left or right.
- Conduit is UL Listed, black, liquid-tight conduit (outside diameter is 7/8").

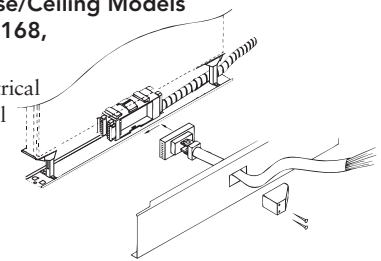

Electrical Infeed Cable Model A871972 and A871972A

- Used to connect the panel electrical system to the building electrical supply.
- A licensed electrician must make connections to a building electrical supply.
- Plugs into the end of a power block. The end-of-panel base pathway cover can be field cut to provide an access port.
- Model uses UL recognized flex-cable conduit — no portion can be left exposed after installation.

Power Infeed Models A871912, A871912A, A871918, and A871918A

- Used to connect the panel electrical system to the building electrical supply, in a ceiling plenum area. Power pole A870071 must be ordered separately.
- A licensed electrician must make connections to a building electrical supply.
- Plugs into the end of a power block.
- Models use UL recognized extra-flex conduit.

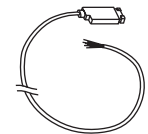
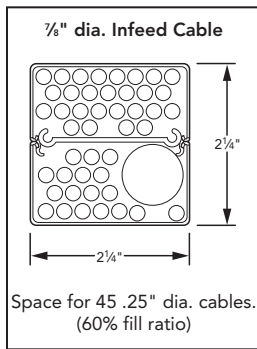

Illustration is representative of all A8719XX models

Note: Infeed cables listed above may be field-cut to desired length. Remove UL Listing/Schematic label and reposition onto the usable length.

Infeeds



Model A870070
Power/Communication Pole
4.5 sq. in.

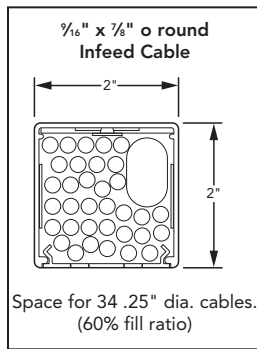

Model A870071
Integrated Power/
Communication Pole
3.3 sq. in.

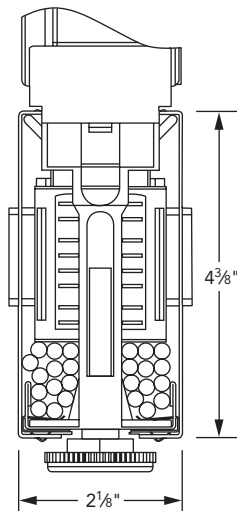

Lower Base Pathway
(2.03 sq. in. below power block,
6.27 sq. in. w/o Power Block for
routing CAT 6 data cables at
60% fill ratio.)

25 CAT 6 with electrical
77 CAT 6 without electrical
(60% fill ratio)

Knockout dimensions:
2.700"W x 1.377"H

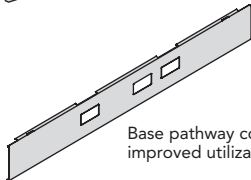
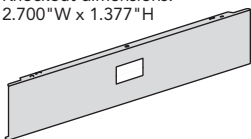

Base pathway covers with additional knockouts are available for improved utilization of power and data.

Electrical

Electrical Components — Concensys (pages 182-183)

- Four-circuit components and three-circuit components (with suffix “A”) cannot be used together.

Electrical Power Harness (page 189)

- Harness will stretch up to 3½" to span a “T” or “X” connection, by stretching.
- Has an extra terminal connection that pass-thru cables do not have (increases connection capacity — required at some “T”/“X” junctions).
- Use power harness in all panels configured adjacent to 18"W panels (if panel run is to be electrified).
- To power all panels at a “T” connection, at least one power harness must be used; at a “X”, at least two power harnesses must be used. An additional power harness is required when using an integrated power pole.

Electrical Pass-Thru Harness (page 189)

- Used to distribute power in panels 24"W and wider.
- Receptacles can be inserted into both sides of power block(s).
- Harnesses will stretch up to 3½" to span “T” and “X” connections.

Jumper Cables (page 189)

- Electrical jumper cable plugs into power block end of electrical power harness or electrical pass-thru harness.

Electrical Pass-Thru Cable (page 189)

- Used to distribute power in panels where receptacles are not required.

Dual Electrical Eight-circuit Power Harness Kit (page 189)

- Kit provides back-to-back four-circuit systems giving double the capacity of harness and pass-thru cables.
- Requires two four-circuit infeeds.
- Uses four-circuit receptacles.
- Four-circuit components and three-circuit components (with suffix “A”) cannot be used together.
- Models must be positioned “back-to-back” in the panel — single-side use is not permitted
- Components can only be routed in a single run — a single run cannot branch to multiple panel runs at “T” and “X” junctions.
- Four-circuit jumper cables (A8713xx) can only be connected to a power block at one end of a run — power cannot be routed between a run in the base pathway area and a run in the beltline area, except at one end of the run.
- Standard four-circuit pass-thru cables (A8710xx) can be used in between power harnesses. Two are required in the back-to-back configurations.
- Models can be connected to standard four-circuit power harnesses and pass-thrus, although it is not recommended because of possible circuit number ambiguity

- Two power infeeds are required to connect the back-to-back runs. Power infeed A8719xx must be connected to a power block at the end of a run.
- Data faceplates and terminals cannot be positioned in a panel into which back-to-back power harnesses are installed.

Duplex Receptacles (page 190)

- Receptacles are marked with circuit number.
- A871601 and A871601A have a 20 amp plug configuration.

Electrical Infeed Cables (page 190)

- A879072 and A879168 can be plugged into any power block.
- Conduit length: base infeed is 6' long, integrated ceiling infeed is 12' or 18' long and ceiling infeed is 14' long.
- Ceiling infeed (A879168) can be used with power pole model A870070.
- Integrated ceiling Infeed cable connects to a prewired electrical harness in the panel base pathway, transverses through the panel connector, and terminates in the junction box at the top of the integrated power pole.

Hardwire Applications (page 190)

- Used when local electrical codes require hardwire entry.
- A871400 or A871400A mounts into panel 30-60"W. When used in 30"W or 36"W panels, power can be routed in only one direction. When used in wider panels, a pass-thru cable for that panel width can be used to route power back in the opposite direction.

Power/Data Dome (page 297)

- Fits into existing grommet hole to provide two surface mounted receptacles and two data ports.
- May interfere with the placement of optional pedestals.
- Can be mounted into field-cut, 2¼" diameter hole.
- 6' black power cord.
- 2 simplex receptacles and 2 data positions.
- Includes adapters to allow use of commercially available data terminals or blanks to fill unused openings.
- Many of the AMP, AT&T, Krone, Leviton, and other commercially available data terminals can be used — terminals must be of a design that will snap into .695 x .650, .590 x .790, or .590 x .750 openings, in .064 max. thick faceplates.

(continued on next page)

Electrical *(continued)***Power/Communication Pole** (page 191)

- Double cavity used to route infeed cable 879168 from ceiling to panel base pathway.
- Conduit of the infeed cable serves as the division of electrical and communications cabling.

Integrated Power/Communication Pole (page 191)

- Installs into 43-82" high or 13"H stacking 90°, "T", and "X" connections.
- In addition to ordering the power pole, an appropriate trim/connector kit must be ordered.
- To power the prewired electrical system, from a ceiling power source, a ceiling infeed cable, model A871912, A871912A, A871918, or A871918A, must be purchased separately.
- Single cavity with removable cover.
- Field-cut to desired length.
- Outside dimension = 2" square.
- For applications requiring integrated power poles longer than 78", an extension kit is available. Contact Allsteel Customer Support for information.
- Not to be used with 120° or 135° connectors.

Trim/Connector Kits (page 191)

- Kit consists of:
 - Panel Top Transition Piece
 - 4" x 4" Junction Box and Cover
 - Drop-Ceiling Trim Plates
 - Panel End Brackets
 - Hardware Pack
- A wood option is not available: use a Flint colored model 87007XP.
- Can function at variable height junctures.

Concensys Connector Bracket Kit (page 191)

- Used to increase vertical cable capacity through the panel connectors
- Increases vertical wire capacity on a single "T" or "X" connector.

Data Port Kit (page 191)

- Allows field installation of additional data ports to Concensys technology panels.
- Knockout dimension: 2.700"W x 1.377"H.

Wireway Grommet (page 191)

- Fits into any receptacle opening.
- Used when routing wires through receptacle opening.

Wire Management Channel (page 191)

- Self-adhesive backing to attach to panels and underside of worksurfaces.
- Contains two cavities for routing wires.
- Note: Each cavity provides space for a maximum of six .25" Dia. cables. Total capacity = 1 sq. in.

Cable Management Tray (page 191)

- Attaches under the worksurface to contain cables.
- Metal tray shelf is 4" deep. Can hold electrical power strip and/or surge protector.
- 24" and 36" lengths, use multiple units for larger worksurfaces.
- Attachment hardware included, paint option is black only.
- Zip tie attachment points located in base of tray. Zip ties not included.

Cord Retainer Clip (page 191)

- Provides confinement of vertical electrical/data wiring.
- 1½"H cord clips snap into vertical panel slots to contain cords.
- 4 clips are provided standard with each tasklight cord.
- Package of 50. Black only.

Cord Organizer (page 191)

- Attached to bottom of worksurface.
- 4"W x ¾"D, made from sheet metal.
- Top sits flush with worksurface if mounted to worksurface.
- 4 cable cut outs: 2 – .250" diameter and 2 – 0.147" diameter; .250" diameter cut outs are centered between the .147" diameter cut outs.

Base Pathway Covers (page 192)

- Features an additional knockout for improved utilization of power and data. Knockouts are 2.700"W x 1.377"H.

Data Faceplates (page 192)

- Fit into receptacle and data port openings in panel base pathway covers, or into data port.
- Due to panel depth, back-to-back data modules should not be used at beltline or in the base.

Specialized electrical may be available through Allsteel Tailored Products Group.

Office Equipment Typical Load Values

Item	*Amps
Desktop Computer	4
Laptop Computer	1
Laptop/Monitor/Docking Station	4
Paper Shredder	1.22
Radio	0.05
Scanner	3
Space Heater (1500 watts)	12
Task Light (equiv. 60-watt bulb)	
Fluorescent	0.12
LED	0.08
USB Charger	0.17
LCD Television (42")	1
LCD Monitor (21")	0.5
Bluetooth Speaker	0.1
Desktop Printer	
Inkjet	0.15
Laser	4 to 10
Multimedia Projector	1.7
Sit-to-Stand Height-Adjustable Desk	Idle 0.01 / Max 4
Office Kitchen	
Coffee Maker	10
Microwave	10
Toaster	12.5
Compact Refrigerator	1.5

*Chart is recommended for planning purposes. Check device specifications for exact amperage. Consult with your electrician regarding the applicable configurations.

Examples of Component Usage based on the *Office Equipment Typical Load Values Chart*

Power Option 3+1

Dedicated Circuit 4: 4 desktop computers with 2 monitors each; or 10 laptop computers
 Utility Circuits 1, 2, 3: Height-adjustable tables and ancillary items

Power Option 2+2

Dedicated Circuit 3: 4 desktop computers with 2 monitors each; or 10 laptop computers
 Dedicated Circuit 4: 4 desktop computers with 2 monitors each; or 10 laptop computers
 Utility Circuits 1, 2: Height-adjustable tables and ancillary items

Power Option 3 (Circuit-separate neutrals)

Dedicated Circuit 3: 4 desktop computers with 2 monitors each; or 10 laptop computers
 Utility Circuits 1, 2: Height-adjustable tables and ancillary items

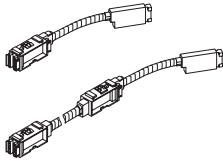

Description	Max. Recept. Cap. per Panel Side	Four-circuit 3 + 1 2 + 2	Three-circuit Separate Neutrals		List Price
Electrical Power Harnesses					
for 24"W panels	1	A871224	A871224A	S	\$ 391
for 30"W Panels	2	A871230	A871230A	S	\$ 391
for 36"W Panels	2	A871236*†	A871236A	S	\$ 391
for 42"W Panels	2	A871242*	A871242A	S	\$ 416
for 48"W Panels	2	A871248*	A871248A	S	\$ 416
for 60"W Panels	2	A871260*	A871260A	S	\$ 416

†When purchased separately without a configurable TAA compliant end product, not on GSA contract.

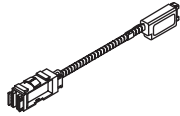

Electrical Pass-Thru Harnesses with Power Block					
for 24"W Panels	1	A871124	A871124A	S	\$ 239
for 30"W Panels	1	A871130	A871130A	S	\$ 239
for 36"W Panels	1	A871136*†	A871136A	S	\$ 239
for 42"W Panels	1	A871142*†	A871142A	S	\$ 255
for 48"W Panels	1	A871148*†	A871148A	S	\$ 255
for 60"W Panels	1	A871160*	A871160A	S	\$ 255
for 72"W Panel Runs	1	A871172	A871172A	S	\$ 341

Electrical harnesses are intended for use with Allsteel systems furniture and are approved under GSA SIN 33721. When purchased separately and used without Allsteel systems furniture, those electrical harnesses marked by () are considered Open Market.

†When purchased separately without a configurable TAA compliant end product, not on GSA contract.

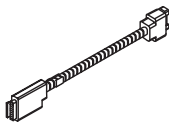

Electrical Pass-Thru Cables without Power Block					
for 24"W Panels	0	A871024	A871024A	S	\$ 219
for 30"W Panels	0	A871030	A871030A	S	\$ 219
for 36"W Panels	0	A871036	A871036A	S	\$ 219
for 42"W Panels	0	A871042	A871042A	S	\$ 229
for 48"W Panels	0	A871048	A871048A	S	\$ 229
for 60"W Panels	0	A871060	A871060A	S	\$ 229

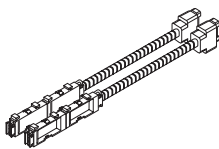

Description	Max. Recept. Cap. per Panel Side	Eight-circuit 3 + 1 (each side) 2 + 2 (each side)		Freight Class	List Price
Dual Electrical Eight-circuit Power Harness Kits					
For 24"W Panels	1	A2-8CIR24	S	100	\$ 939
For 30"W Panels	2	A2-8CIR30	S	100	\$ 939
For 36"W Panels	2	A2-8CIR36	S	100	\$ 1358
For 42"W Panels	2	A2-8CIR42	S	100	\$ 1358
For 48"W Panels	2	A2-8CIR48	S	100	\$ 1358
For 60"W Panels	2	A2-8CIR60	S	100	\$ 1369

Note: Kit consists of two four-circuit harnesses placed "back-to-back" to provide 8 circuits.

<p>How to specify — Select the Concensys Model Number from above.</p>	<p><i>1st Option:</i> Color: P Black</p>	
<table border="1" style="width: 100%; height: 20px;"> <tr> <td style="width: 10%; text-align: center;">P</td> </tr> </table>	P	
P		

Examples: A871130.P A2-8CIR36.P

S Shippable by small-package carrier.

For specification information see pages 182-188.

GSA SIN 33721



Each marked with Circuit Number.

Description	Four-circuit 3 + 1 2 + 2	Three-circuit Separate Neutrals		List Price
Duplex Receptacles				
Circuit 1	A871501	A871501A	S	\$ 72
Circuit 2	A871502	A871502A	S	\$ 72
Circuit 3 (except 2+2 – see below) iso/dedicated	A871503	A871503A	S	\$ 72
Circuit 3 (2+2)	A871506		S	\$ 72
Circuit 4 — iso/dedicated circuit	A871504		S	\$ 72
Circuit 1 (20 amp outlet configuration)	A871601	A871601A	S	\$ 72

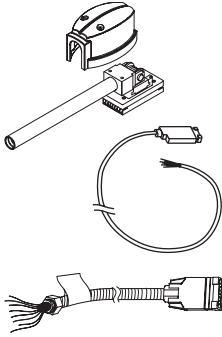

Power Infeed Cables

Base Receptacle Infeed (6' long conduit) (Sealtight Cable — 7/8" diameter)	A879072	A879072A	S	\$ 439
Electrical Infeed Cable (14' long conduit) (Sealtight Cable — 7/8" diameter)	A879168	A879168A	S	\$ 1059
Electrical Infeed Cables (6' long conduit) (Flex Cable)	A871972	A871972A	S	\$ 331
Integrated Ceiling Infeed (12' long conduit) (Flex Cable)	A871912	A871912A	S	\$ 449
Integrated Ceiling Infeed (18' long conduit) (Flex Cable)	A871918	A871918A	S	\$ 565

NOTE: For use with integrated power pole model A870071.

Use when local codes require.

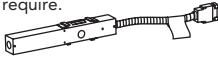

Hardwire Applications

Hardwire Power Infeed	A871400	A871400A	S	\$ 431
Hardwire Junction Box (6-pack)	A871500	N/A	S	\$ 931

NOTE: Junction box can be positioned at any duplex receptacle location. Customer must furnish conduit, wiring, and designer-type receptacles. Not for use at beltline in technology panels. (Approved for use by city of Chicago.)

Receptacle Color Recommended to Coordinate with Paint Color

Paint Color	Recommended Receptacle Color
Carob — P52 (<i>De-emphasized</i>)	Black — E4
Champagne Metallic — PR5	Muslin — EU
Fossil — P28	Flint — E9
Gunmetal Metallic — PR3	Brownstone — EY
Parchment — P93	Muslin — EU
Platinum Metallic — PR2	Loft — EV

<p>How to specify — Select the Concensys Model Number from above.</p>	<p><i>1st Option:</i> Electrical Receptacle Color (if applicable): See page 180 for finishes.</p>	<p><i>1st Option:</i> Color (if applicable): P Black</p>	<p>_____ . E P</p>
--	--	---	--

Examples: A871501.EU A879072.P A871400.P A870300.P

S Shippable by small-package carrier.

For specification information see pages 182-188.

GSA SIN 33721

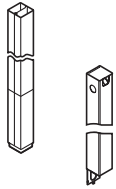

Description	Model	P1 Paint List Price
Power/Communication Pole		
10'5" long w/o Receptacles — 2¼" square	A870070	\$ 799

Note: Black only.

Integrated Power/Communication Pole		
7'8" long — 2" square	A870071	\$ 387

Note: Conduit of the infeed cable serves as the division of electrical and communications cabling. Refer to Cross-Sectional Views in the Systems Specification Guide. Order trim kit below.

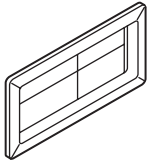

Wireway Grommet		
6-Pack (Black only)	TAWG S	\$ 187

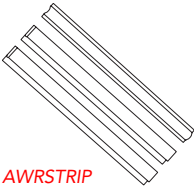

AWRSTRIP

Wire Management Strips/Channels		
	AWRSTRIP S	\$ 270

- Four wire management strips/channels in black only, no specification needed.
- *Example: AWRSTRIP*

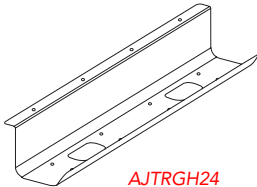

AJTRGH24

Cable Management Trays		
24"W	AJTRGH24 S	\$ 123
36"W	AJTRGH36 S	\$ 147

- Available in 24" or 36" widths.
- Metal Cable Management Trays available in Black only, specify "P" for finish.
- *Example: AJTRGH24.P*

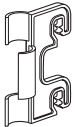

Cord Retainer Clip		
Package of 50 (Black only)	AAPACM2 S	\$ 56

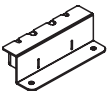

Cord Organizer		
4"W x ¾"D Metal with 4 cable cutouts	U9WTC S	\$ 196

<p>How to specify — Select the Concensys Model Number from above.</p> <p>_____ . _____</p>	<p><i>1st Option:</i> Paint (if applicable): P See page 180 for finishes.</p> <p>Fossil, Parchment and P2 Paints not available on A870070.</p> <p>P _____</p>	<p><i>1st Option:</i> Wireway Grommet Color (if applicable): E4 Black</p> <p>E 4</p>	<p><i>1st Option:</i> Wire Management Channel Color: P Black</p> <p>P</p>
---	--	---	--

Examples: A870070.P27 TAWG.E4 AJTRGH36.P AAPACM.P27

S Shippable by small-package carrier.

Electrical & Data

For specification information see pages 182-188.

GSA SIN 33721

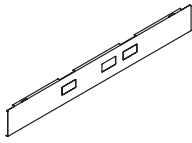

Description	Model	P1 Paint List Price	P2 Paint List Price
Base Pathway Covers — with additional knockout			
36"W	CBPLATE3-36	\$ 101	\$ 119
42"W	CBPLATE3-42	\$ 103	\$ 121
48"W	CBPLATE3-48	\$ 110	\$ 128
60"W	CBPLATE3-60	\$ 127	\$ 145

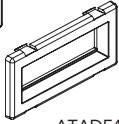
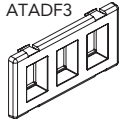

ATADF4

Data Faceplates

Three-Port Flex-Mode Faceplate, Black (E4)	ATADF3 S	\$ 42	N/A
Four-Port Flex-Mode Faceplate, Black (E4)	ATADF4 S	\$ 42	N/A

Note: ATADF3 can install up to 3 jacks (CAT 3, 5E, or 6). ATADF4 can install 4 jacks (CAT 3, 5E, or 6).

Allsteel's data faceplates are designed for use with the jacks listed below. We do not guarantee compatibility with other manufacturers' product. A faceplate adapter is available for use with alternatively sourced data jacks, see the Standard Specials catalog for details.

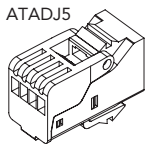

Jacks

RJ45 CAT 5E Jack — Black only			
Toolless	ATADJ5 S	\$ 74	N/A
AMP RJ45 CAT 6 Jack — Black only			
Requires Tool	ATADJ6 S	\$ 98	N/A

<p>How to specify — Select the Concensys Model Number from above.</p>	<p><i>1st Option:</i> Paint (Base Pathway Cover only): P1 P2 See page 180 for finishes.</p>	<p><i>1st Option:</i> Data Faceplate Color: E4 Black</p>
<div style="display: flex; justify-content: space-between; width: 100%;"> _____ . P _____ </div>		<div style="display: flex; justify-content: center; width: 100%;"> E _____ </div>

Examples: CBPLATE3-36.P28 ATADF4.E4

S Shippable by small-package carrier.

Add Suffix "N" to model number for no grommets, no upcharge.

Flat Edge

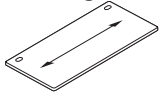

Primary

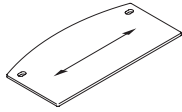

Bow Front

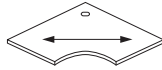

Corner with Radial Edge

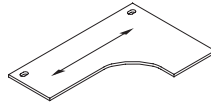

Corner Cove

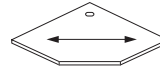

Corner with Straight Edge



Flat Edge Detail

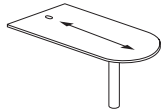

Peninsula

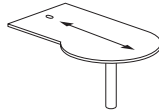

P-Shaped

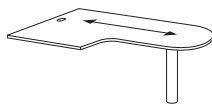

Jetty

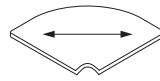

Quarter-Round



D-Shaped

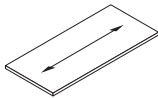

Straight Countertops



Corner Countertops

←→ Arrows indicate grain direction for woodgrain laminates.
Grain direction on symmetrical corner worksurfaces runs at a diagonal.

Note: T-mold is used on the edge of curved worksurfaces. This will have a noticeable visual difference when directly adjacent to straight worksurfaces.

Primary Worksurface

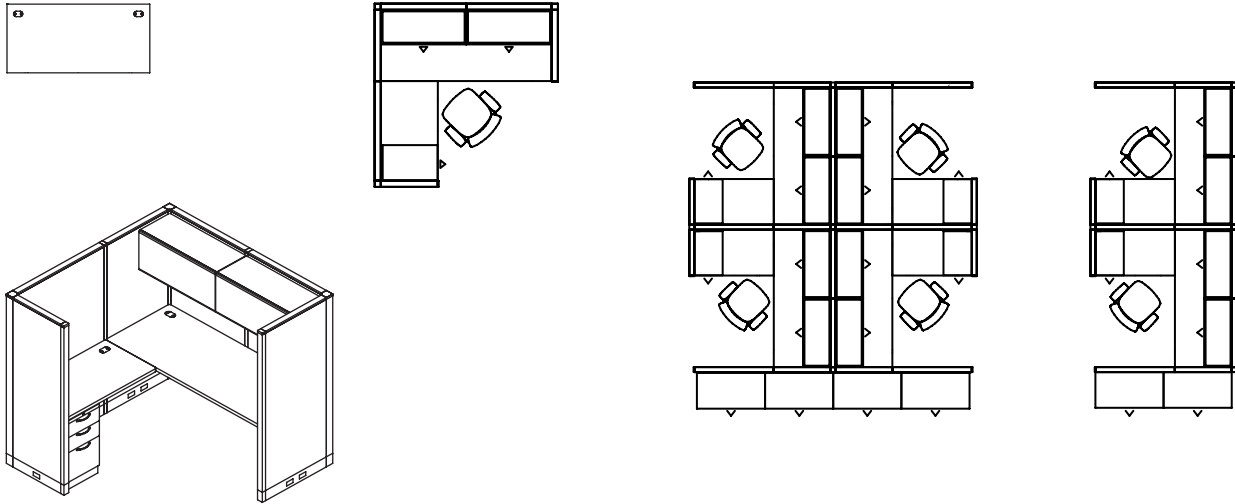

Corner Worksurface

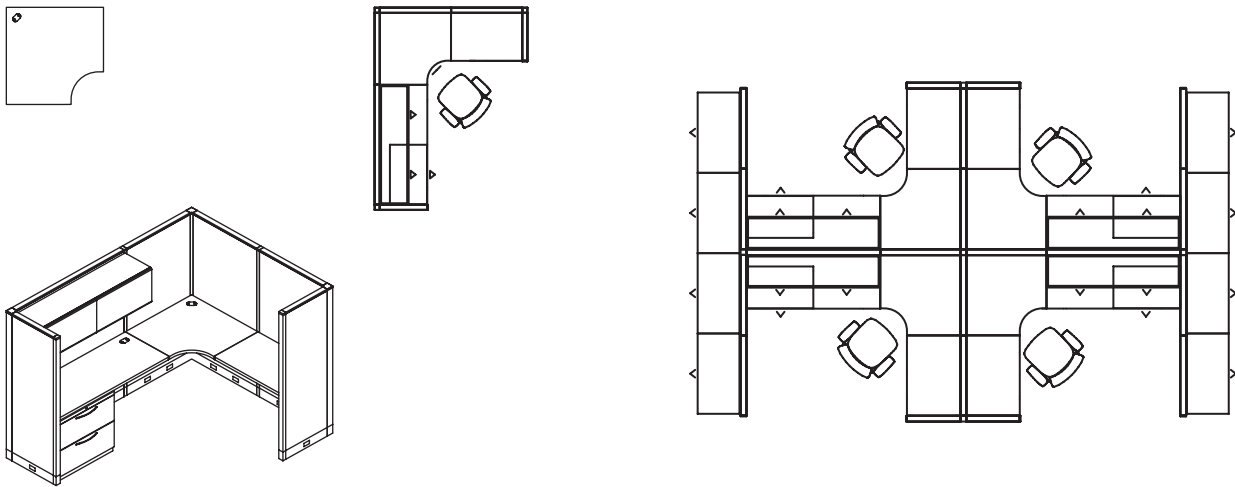

Cove Worksurface

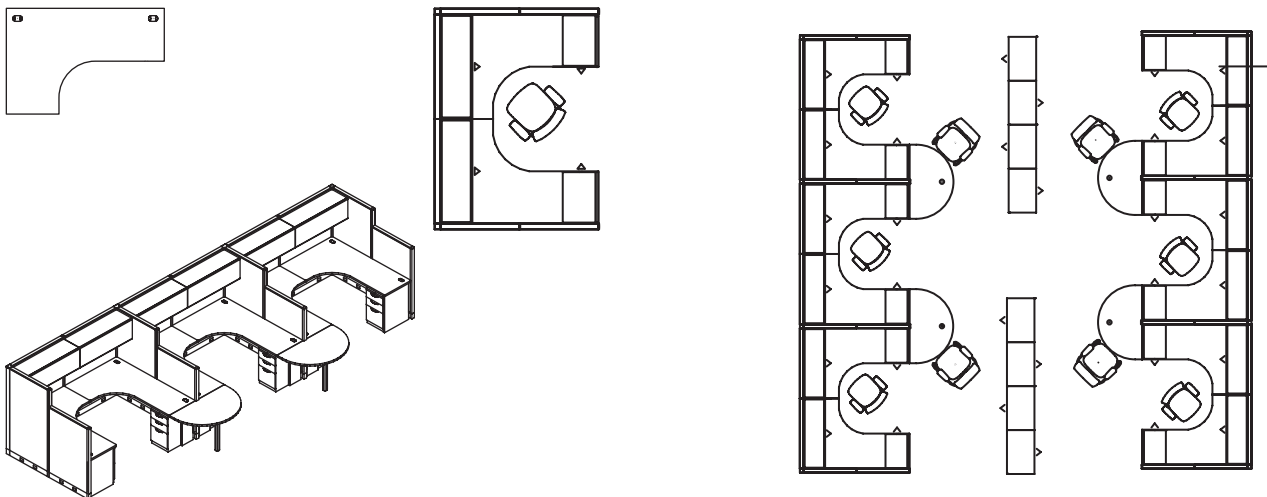

Note: Similar Typical CAD files and BOM are available at <https://www.allsteeloffice.com/design-resources/idea-starters>.

Peninsula Worksurface

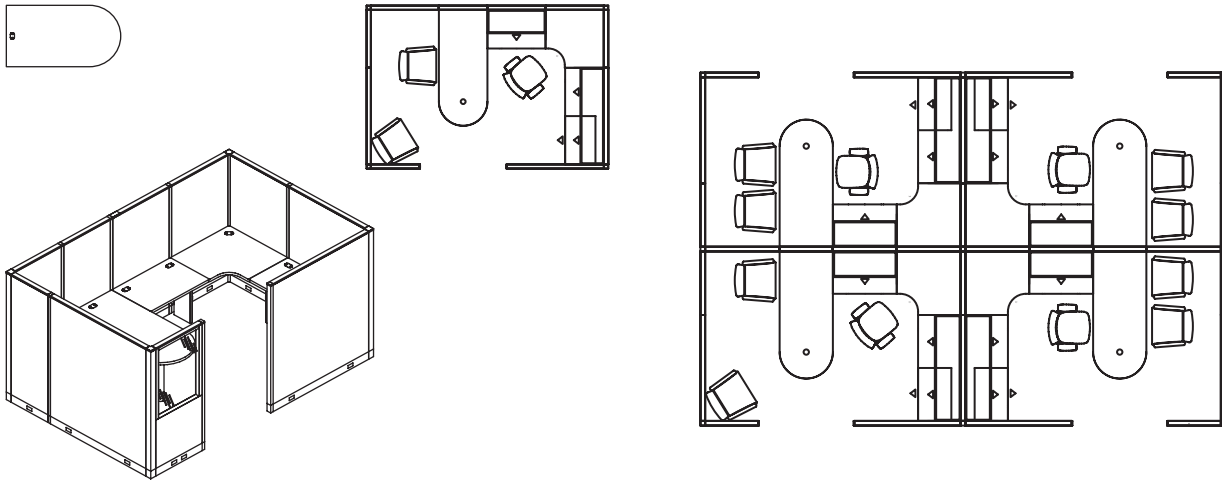

P-Shaped Worksurface

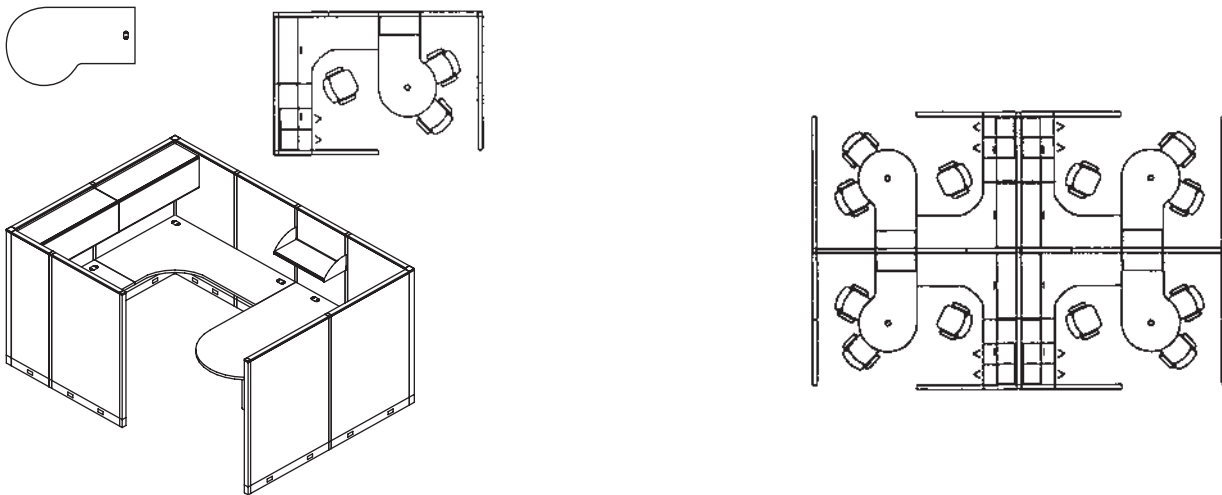

Jetty Worksurface

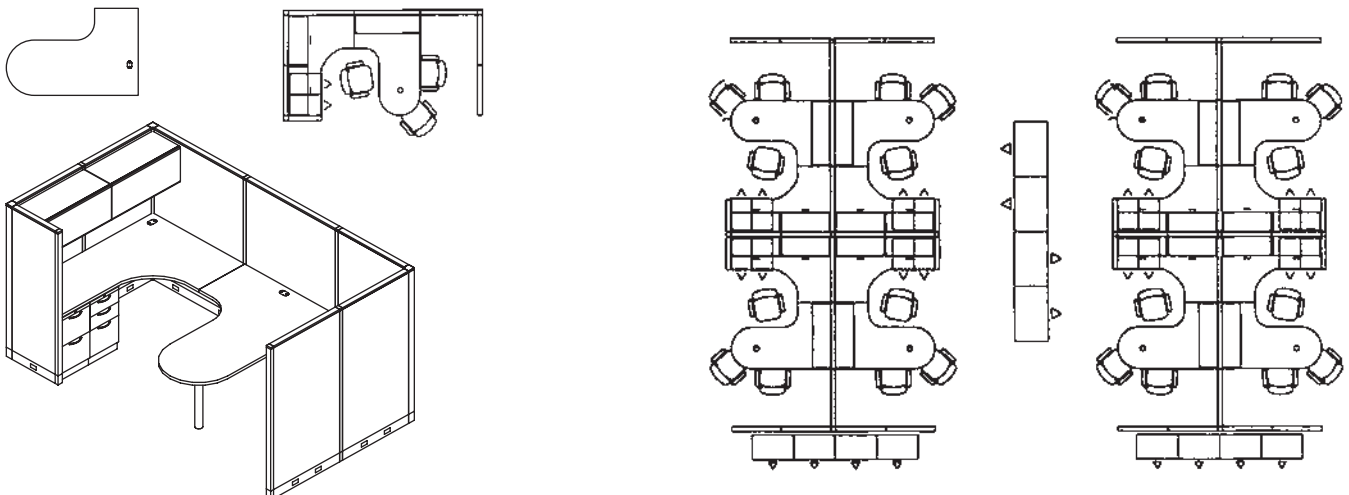

Note: Similar Typical CAD files and BOM are available at <https://www.allsteeloffice.com/design-resources/idea-starters>.

D-Shaped Worksurface

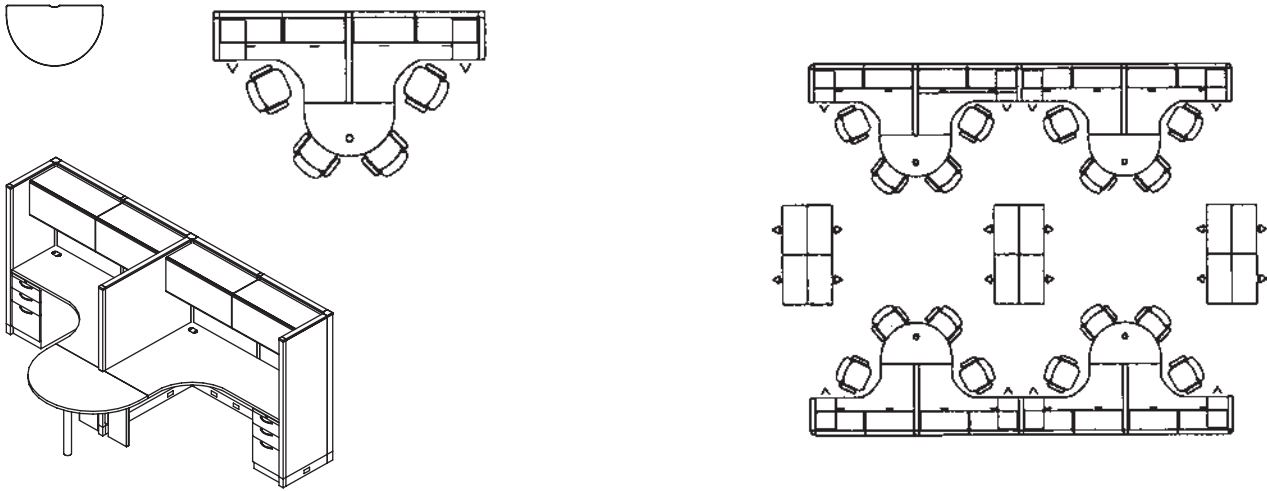

Countertop Worksurface

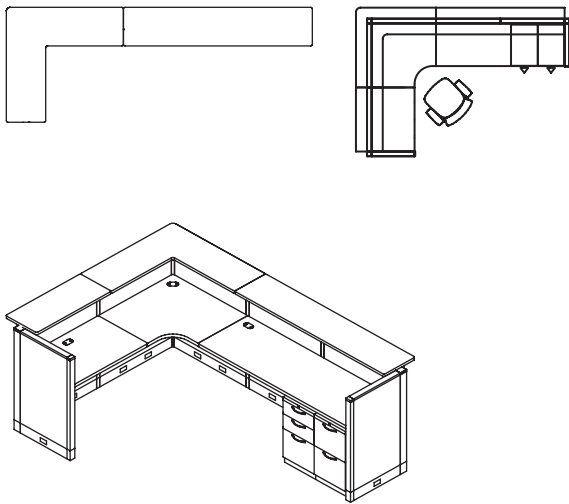

Note: Similar Typical CAD files and BOM are available at <https://www.allsteeloffice.com/design-resources/idea-starters>.

Support Guidelines — See Drawings below

- Panel mounted worksurface runs 96" and greater need floor support for improved stability when overheads are not used.
- When using overheads in panel mounted worksurface run applications 72" and greater, floor support is required.
- When using overheads at the end of a panel run, floor supports are required.
- Worksurface bracket kit should be used to tie panels to worksurface for added stability.
- A return panel at the end of a panel run can be substituted with one of these floor supports: storage, open or closed end support panel, O-leg.
- Cantilever brackets cannot be be used at the end of a worksurface

- panel run in place of a return panel or floor support.
- Worksurface runs 60"W or greater require an external worksurface support channel when a center support cantilever cannot be used. It is recommended for spans greater than 48"W. See pages 200 and 211.
- Support channel may interfere with mounting of some CPU holders and keyboard supports.
- Cantilevers are recommended in place of an external worksurface support channel where feasible.
- Cadence Desking configurations utilize modesty panels and gussets in place of external support channels for worksurfaces up to 72"W. See pages 201-209.

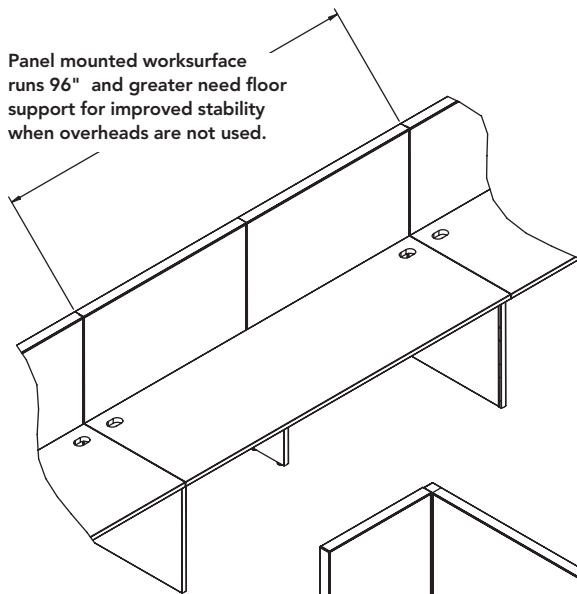

Panel mounted worksurface runs 96" and greater need floor support for improved stability when overheads are not used.

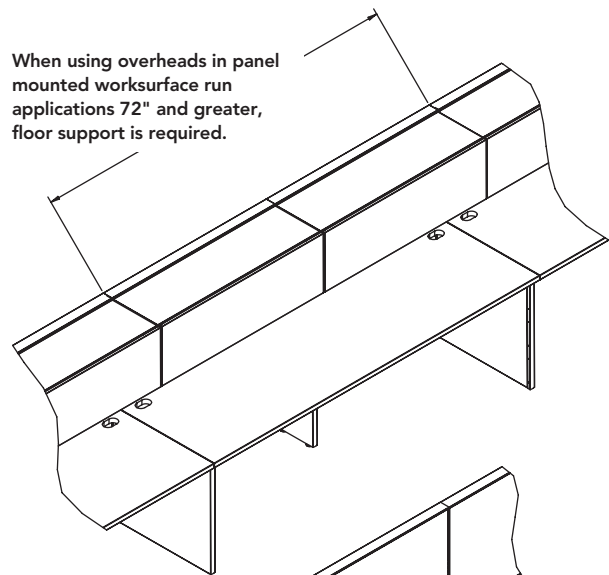

When using overheads in panel mounted worksurface run applications 72" and greater, floor support is required.

Worksurface bracket kit should be used to tie panels to worksurface for added stability

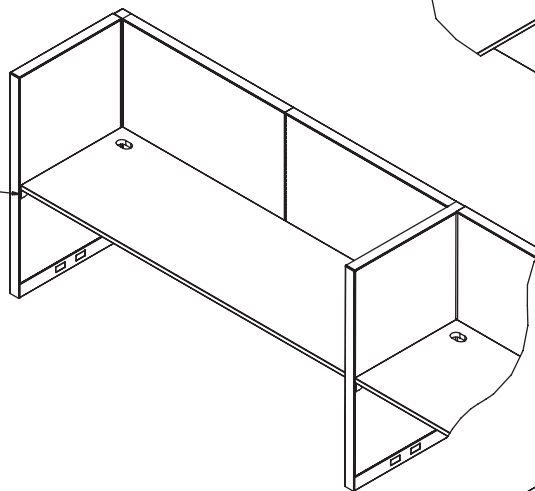
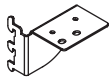

These floor supports can substitute a return panel at the end of a panel run: storage, open or closed end support panel, O-legs.

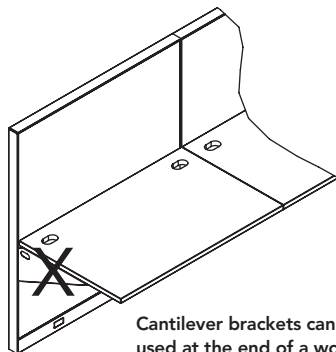

Cantilever brackets cannot be used at the end of a worksurface panel run in place of a return or floor support.

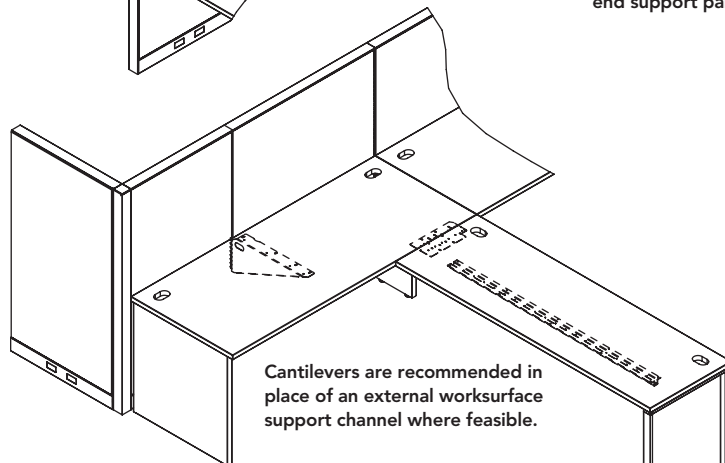

Cantilevers are recommended in place of an external worksurface support channel where feasible.

Worksurface runs 60"W or greater require an external worksurface support channel when a center support cantilever cannot be used. It is recommended for spans greater than 48"W. See pages 200 and 211.

Flat Edge Worksurfaces

Worksurfaces (pages 210-218)

- Worksurfaces can be specified without grommets by adding suffix “N” to model number for no grommet, no upcharge.

Primary Worksurfaces (page 210)

- 24", 30", 36", and 42"W worksurfaces have one grommet, centered; two on widths 48"W and greater.
- Width must correspond with panel width(s). For worksurface to span a “T” or extended straight connection add “T” suffix and upcharge. (All T-span worksurfaces are available in Express Solutions™ except 72"W models.)
- Worksurfaces 60"W or greater require a cantilever bracket for center support in panel mounted applications. Specify 18" cantilever on 20"D and 24" cantilever on 24"D and 30"D worksurfaces.
- Primary worksurfaces can be used with a modesty panel and appropriate supports to configure freestanding desk(s). Refer to Working with Cadence®, pages 201-209.

Bow-Front Worksurfaces (page 211)

- Standard with two wire management grommets.
- Wave and bow-front worksurfaces can be used with a modesty panel and supports to configure freestanding desk(s). Refer to Working with Cadence, pages 201-209.

Corner Worksurfaces (page 212)

- Panel-hung application requires two panels of corresponding width joined at 90°.
- Does NOT include rear support bracket. If rear support bracket is needed, order T6BK. Worksurface bracket kit (order separately) required at junction where a panel is wall-mounted to a permanent wall and wall track stanchion is not positioned in the right hand corner.
- Leading edge of radial leading edge units has an inside radius of 10%".
- With woodgrain laminate, grain direction is diagonal to grain of adjacent worksurface(s).
- Corner worksurfaces can be used with a modesty panel and appropriate supports to configure freestanding desk(s). Refer to Working with Cadence, pages 201-209.
- One wire management grommet in corner standard.
- T-mold is used on the edge of curved worksurfaces. This will have a noticeable visual difference when directly adjacent to straight worksurfaces.

Corner Shelves (page 212)

- Diagonal leading edge = 10½"
- Diagonal depth = 22½"
- Includes panel attachment brackets.
- Laminate with flat edge.

Corner Cove Worksurfaces (page 213)

- Worksurfaces greater than 60"W require a cantilever bracket for center support in panel mounted applications. Specify 18" cantilever on 24"D, and 24" cantilever on 30"D worksurfaces.
- Standard with two wire management grommets.
- Corner cove worksurfaces can be used with a modesty panel and appropriate supports to configure freestanding desk(s). Refer to Working with Cadence, pages 201-209.
- Does NOT include rear support bracket. If rear support bracket is needed, order T6BK. Worksurface bracket kit (order separately) required at junction where a panel is wall-mounted to a permanent wall and wall track stanchion is not positioned in the right-hand corner.
- T-mold is used on the edge of curved worksurfaces. This will have a noticeable visual difference when directly adjacent to straight worksurfaces.

Altitude® Height-Adjustable (page 213)

- For freestanding applications, see height-adjustable tables in the Seating, Collaboration, and Tables Price List.

(continued on next page)

Flat Edge Worksurfaces *(continued)***Peninsula, P-Shaped, and Jetty Worksurfaces**

(page 214)

- Standard with one wire management grommet.
- Support column ordered separately, column includes panel support brackets 831099.
- Peninsula worksurface must correspond to the width of its support panel.
- Peninsula and P-shaped worksurfaces can also be attached perpendicularly to a primary worksurface using flat brackets. Do not attach to a worksurface supported with cantilever brackets.
- Worksurfaces can be used with a modesty panel and appropriate supports to configure freestanding desk(s). Refer to Working with Cadence, pages 201-209.

Quarter-Round Worksurfaces (page 215)

- Connects two 90° panel-attached worksurfaces.
- Order support column and two flat brackets separately.

D-Shaped Worksurfaces (page 215)

- Order support column and two 11"D end panels separately.
- Not recommended for use with cantilever brackets CCB24L or CCB24R for shared applications.
- Worksurface includes attachment brackets.
- Use only with other worksurfaces with matching edge.

Countertops (page 216)

- Countertops cannot be used with 32"H panels.
- Corner countertops require two panels of corresponding width joined in an "L".
- T-mold is used on the edge of curved worksurfaces. This will have a noticeable visual difference when directly adjacent to straight worksurfaces.

Non-Standard Worksurface Sizes (pages 217-218)

- The 9120 Program can be used to order particle board rectangular worksurfaces in any non-standard width and depth in 1/8" increments up to a maximum of 120"W x 36"D.
- Other modification requests should be made through Allsteel Tailored Products Group.

Supports

End-Panel Support (page 219)

- Non-handed for use at either end of worksurface.
- Levelers provide 1½" vertical adjustment.
- Must be connected into panel slots for panel-hung applications.
- Can be converted to freestanding with removal of panel-mount bracket.
- Straight worksurfaces adjacent to 120° and 135° connections must be supported by full end panels.
- 11"D models for use with D-shaped worksurfaces or curvilinear shaped worksurfaces in freestanding applications.

Support Leg (page 219)

- Non-handed for use at either end of worksurface. Leg portion is 12¾"D.
- Use in a shared position or at 90° panel junctions to support adjoining worksurfaces or to support a worksurface adjacent to a dual-surface worksurface.
- Flat bracket included.
- Levelers provide 1½" vertical adjustment.
- Must be connected into panel slots for panel-hung applications.
- Can be converted to freestanding with removal of panel-mount bracket.

Support Column (page 220)

- Used to support one end of curvilinear worksurfaces. (Includes panel support brackets.)
- Levelers provide 1½" vertical adjustment.

Permanent-Wall Hanger Kit (page 220)

- Mounts to permanent dry-wall to hang panel-hung components.
- Wall track has ½" x ½" slots on 1" centers.
- Customer to furnish connecting hardware. (Refer to Concensys Installation Instructions for appropriate hardware.)
- Worksurfaces should not be supported with cantilever brackets when using permanent-wall hanger kit.
- An integral channel is provided for vertically routing task light cords.
- Includes a cover for top of channel.

Cantilever Brackets (page 219)

- Use with runs less than 96". Floor support is required for runs 96" and longer.
- Where applicable, cantilevers are recommended over an external worksurface support channel. Worksurface runs over 60"W require an external worksurface support channel when a cantilever cannot be used.
- Do not use at the end of a worksurface where no 90° return panel is positioned.
- Includes tie bracket and attachment hardware.
- Avoid installation on only one side of a straight connection except to support corner worksurfaces.

- DO NOT use to support worksurfaces from which a hanging pedestal is suspended, or to which a peninsula worksurface is attached.
- DO NOT use cantilever brackets to support worksurfaces supported with permanent-wall hanger kit.
- Do not use with wall track or to support a worksurface to which a return worksurface is attached.

Cantilever Bracket — Handed (page 219)

- Cantilever brackets are handed (left or right) and can be inserted into panel reveals in 1" vertical increments. No assembly required.
- Left- and right-hand brackets required in shared applications.
- 24"D cantilevers are required to be used for both 24"D or 30"D worksurfaces.
- 18"D cantilevers are required to be used for 20"D worksurfaces or center support for 24"D.
- 12"D cantilevers are required to be used for 12"D worksurfaces.

Cantilever Bracket — Non-Handed (page 219)

- Cantilever brackets are non-handed and can be inserted into panel reveals in 1" vertical increments. Assembly required.
- One bracket in shared applications — includes two angled brackets.
- Bracket accommodates 24"D or 30"D worksurfaces.

Worksurface-to-Panel Bracket (page 219)

- Model 831324 mounts to a 24"W panel to support a 24"D worksurface.
- Model 831330 mounts to a 30"W panel to support a 24"D or 30"D worksurface.

Worksurface Bracket Kit (page 219)

- Used to connect the end of a worksurface to a panel of the same width.

Flat Brackets (page 219)

- Flat Brackets can be used to connect one worksurface perpendicularly to another worksurface.

Pedestal-to-Panel Attachment Bracket (page 219)

- Can be used in place of full end panel or return panel.
- Provides structural support to panel run by securing panel directly to pedestal.
- Is compatible with Align™ and Essentials™ pedestals.

External Worksurface Support Channel (page 211)

- Is required on a systems worksurface for additional support for spans greater than 60"W. Width of worksurface span can be reduced by using support storage.
- Extends 1½" below the worksurface. Installs 7" from user's edge.
- When using 28"H mobile pedestals the length of support channel needs to be reduced to accommodate width of the pedestal.
- Support channel may interfere with mounting of some CPU holders and keyboard supports.

Cadence offers unlimited versatility. Its modular flexibility creates office solutions of all shapes, sizes, and styles.

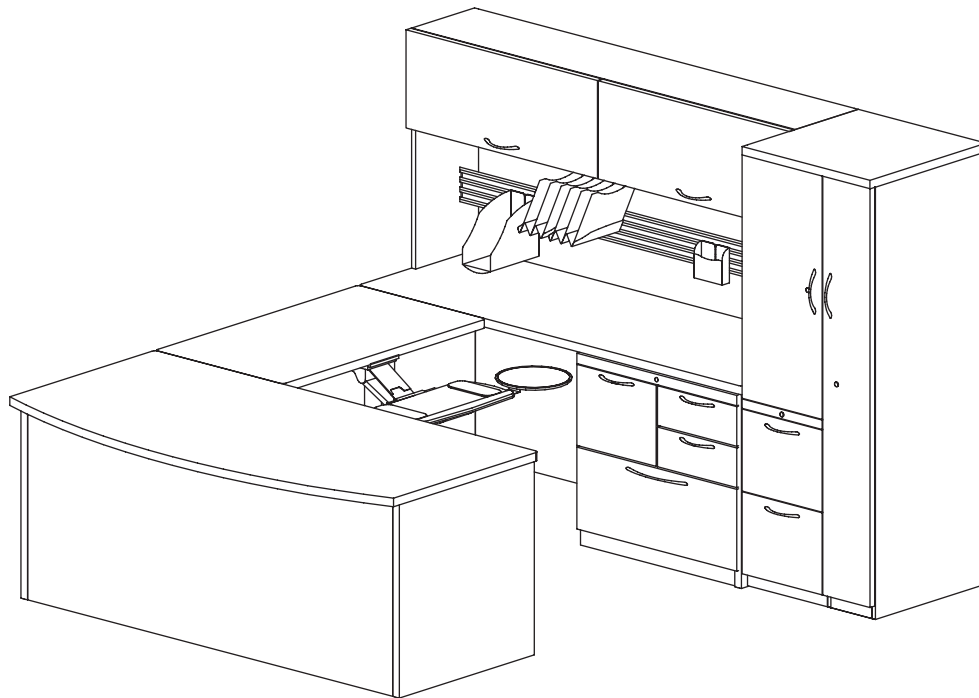

Configurations



Full Modesty

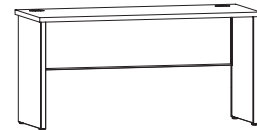

Half Modesty



Gussets

All the right choices

Choose Cadence freestanding desking with confidence. It personalizes any work environment, accommodates a range of needs, and offers all the right features — curvilinear worksurface shapes, multiple worksurface edges, and a complete paint finish and laminate offering. Cadence is made to last with heavy-gauge steel construction. Metal-to-metal worksurface connection points make installation and reconfiguration reliable and easy. And Cadence is backed by a lifetime warranty.

Universally flexible

Cadence sets up easily and reconfigures time after time. It even shares components with Optimize™, Terrace®, and Concensys, which simplifies inventory management. Cadence is created with worksurfaces, supports, modesty panels, end panels, and brackets. Cadence is compatible with the entire line of Allsteel storage solutions and Extensions — work tools to provide personalized organization for every workstyle.

Systems integration — Cadence works in combination with Optimize, Terrace, or Concensys panels, extending the functionality of both product lines.

Highly adaptable — Make the most of building architecture by using an existing wall to create a semi-private workspace.

Space utilization — Multiple worksurface shapes offer unlimited design potential for using space creatively and efficiently.

Team interaction — Cadence design flexibility allows you to create personal workspace and a team collaboration area in the same office.

The Cadence Choice

It works in the open plan, the private office, or in combination with Optimize, Terrace, or Concensys panels, allowing complete office coordination. The flexible, universal design of Cadence supports virtually any workstyle and any interior aesthetic. Backed by Allsteel's Lifetime Warranty and manufactured to strict environmental standards, Cadence provides one high-value package.

Configurations

End Panels **E** and Support Legs **L**

Each are available in two options: freestanding or panel-mount. The only difference between the two options are the panel-mount models come with a left- or right-handed bracket to attach the support to a panel in a Cadence systems application. If the freestanding version is purchased and later needs to be converted to panel-mount, the proper handed panel-mount bracket may be purchased separately.

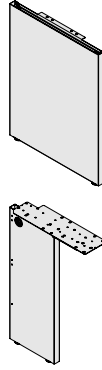

The 11" D end panel is used to freestand peninsulas, curvilinear shapes, and D-tops in panel applications.

Corner Desk Legs **C**

Corner desk legs have a 90-degree bend and welded construction. The strong construction, allows gussets or half-height modesty panels to be used with corner legs.

Bridge Kits **B**

Bridge kits include: two flat brackets, two modesty panel-to-end panel attachment brackets, and two tie straps. This kit is used when attaching a bridge unit between two rectangular worksurfaces.

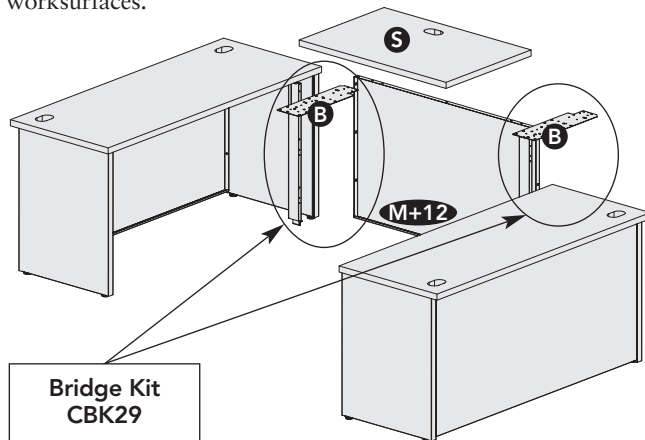

Return Kits **R**

Return kits include: one flat bracket, one modesty panel-to-end panel attachment bracket, and one tie strap. These are used when attaching a return to a primary desk. Return kits can also be used in some bridge applications — one example is shown below when using a peninsula.

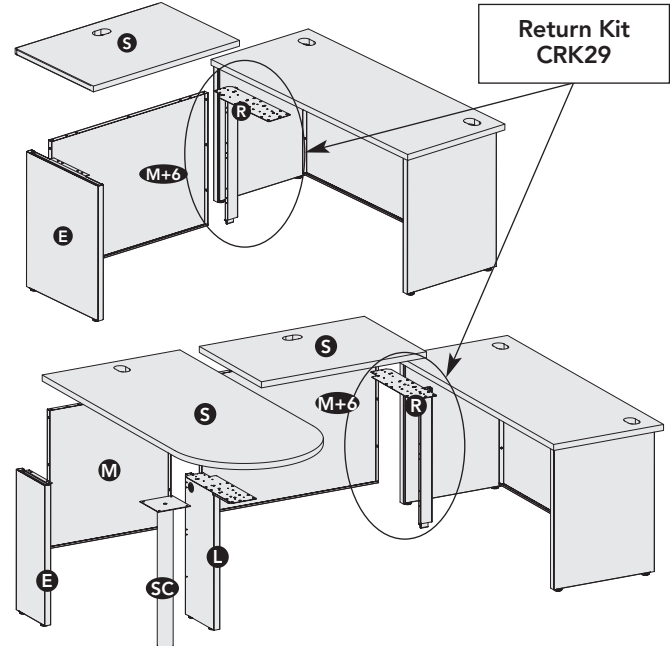

Desk-to-Panel Attachment Kits **D**

Desk-to-panel attachment kits are used to connect a worksurface and modesty panel perpendicular to a panel of corresponding width. Opposing end of worksurface must be attached with an end-panel, support leg, or corner leg mounted directly under this worksurface.

When using a corner or corner cove worksurface with the rear corner attached to a panel, and opposing end of worksurface is attached to a freestanding desk — use corner w/desk attachment kit. “Hand” of unit is determined from the user’s side of the desk (right hand unit attaches to right side of modesty).

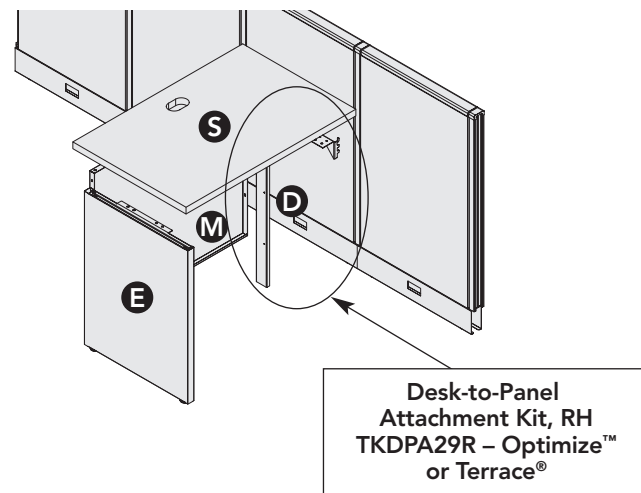

There are some bridge instances where only half of a bridge kit is needed (e.g., using a bridge between a rectangular worksurface and a corner or peninsula). A return kit may be ordered for these instances.

Surface **S**

Support Column **SC**

Corner w/Desk Panel Attachment Kit **CW**

Corner w/desk panel attachment kit connects the rear corner of a corner or corner cove worksurface and modesty panel to a panel when the opposing end of the worksurface shares a support leg with an adjacent freestanding desk and the support leg is mounted under the freestanding desk. “Hand” of unit is determined from the user’s side of the desk (left hand unit attaches to left side of modesty).

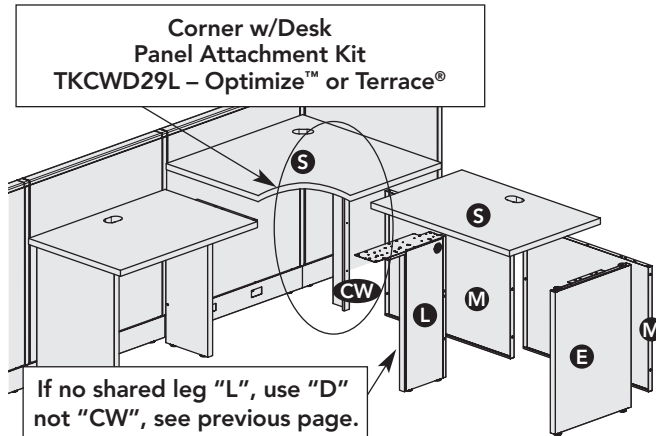

Corner Worksurfaces

Corner worksurfaces to accommodate 90-degree corner desk legs.

In-Line Connections of Desks

Freestanding full end panels must be used to support adjacent rectangular desks, corner desks, and corner desks with returns. Freestanding support legs should NOT be used at the in-line junction. 24"D full end panels may be used at the in-line junction on 30"D rectangular desks if two worksurface tie straps are used to secure the desks together. Contact Allsteel Customer Support for ordering information.

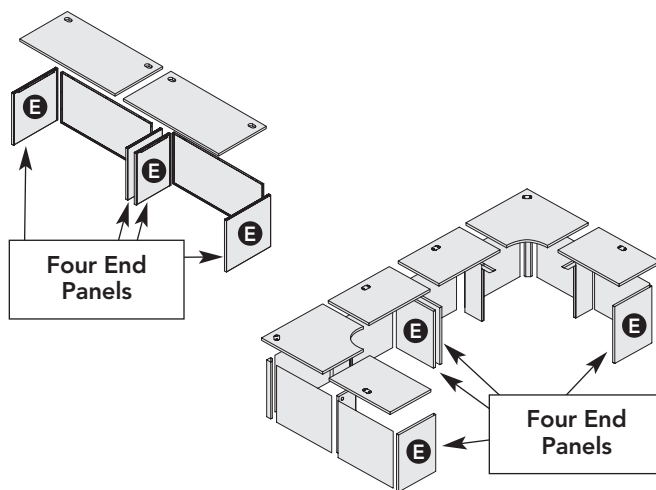

Pedestals and Storage

Pedestals must be ordered one size smaller than the depth of the worksurface. For example, 18"D or 20"D peds should be used with 24"D worksurfaces. 18"D, 20"D, or 23"D pedestals can be used with 30"D worksurfaces. Using 18"D laterals or personal files provide additional pull style and storage options under 24"D worksurfaces.

Modesty Panels **M**

The following are some general guidelines for Cadence modesty panels:

- **Desk:** Modesty panel width is the same width as the worksurface
- **Return:** Modesty panel width is 6" greater than the width of the worksurface
- **Bridge connecting two rectangular worksurfaces:** Modesty panel width is 12" greater than the width of the bridge worksurface
- **Bridge connecting a rectangular worksurface and corner or peninsula:** Modesty panel width is 6" greater than the width of the worksurface
- **Corner connecting to an adjacent worksurface:** Modesty panel width is the same width as the worksurface.

Stand-Alone Corner Modesty Panels **SM**

Stand-alone corner modesty panels are used only when one or both sides of a corner or corner cove worksurface are freestanding and NOT attached to another worksurface. Specify the width the same as the width of the worksurface.

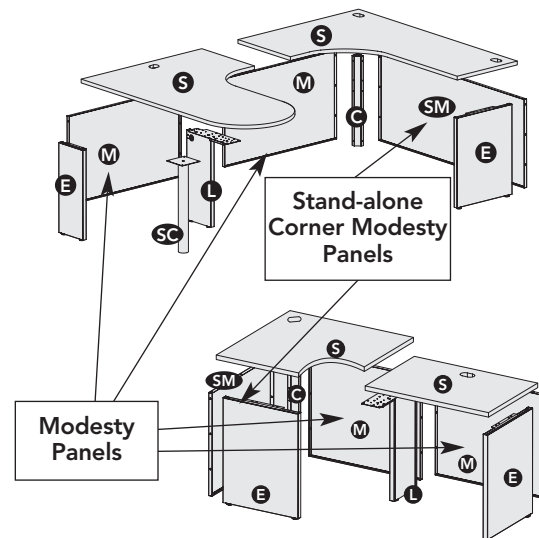

Gussets **G**

Gussets can be used in place of a modesty panel with desks 36"W to 60"W. Gussets can also be used with corner desk legs.

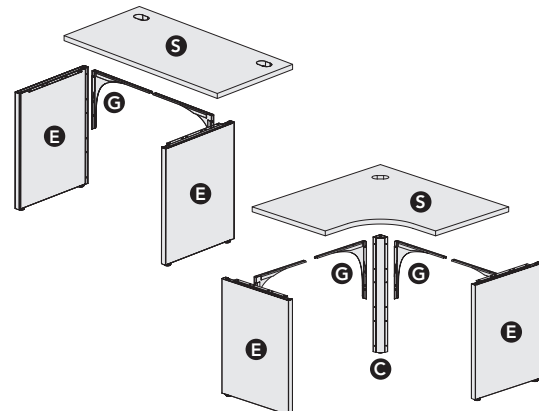

Configurations

Freestanding Desk

Example Shown		
Qty.	Model	Description
1	T52436S	Flat Edge Worksurface 24"D x 36"W
2	CEP2429F	End-Panel Support 24"D x 29½"H
1	CS369	Modesty Panel 36"W x 29½"H

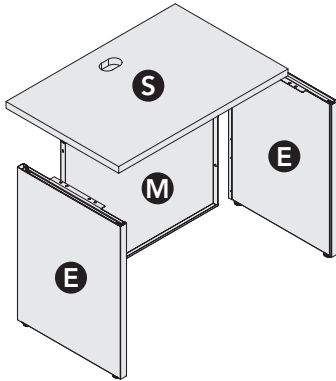

Panel-Attached Desk

Example Shown		
Qty.	Model	Description
1	T52436S	Flat Edge Worksurface 24"D x 36"W
1	CEP2429F	End-Panel Support 24"D x 29½"H
1	CS369	Modesty Panel 36"W x 29½"H
1	□DPA29R	Desk-to-Panel Attachment Kit 29½"H – RH C – Concensys TK – Optimize™ or Terrace®

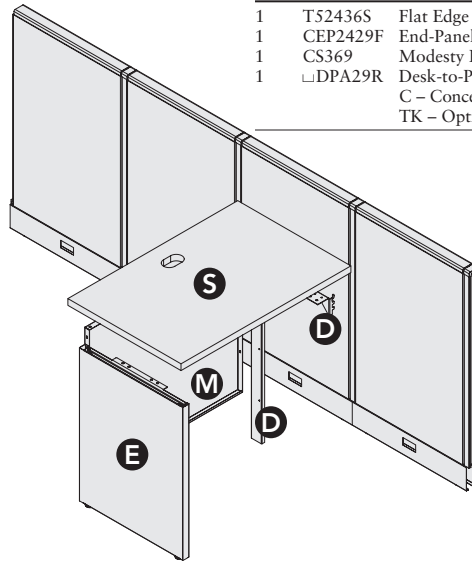

CONFIGURATION OPTIONS	Work-surface (S)	End-Panel Support (E)	Desk Support Leg (L)	Modesty Panel			Desk-to-Panel Attachment Kit (D)	Corner Desk Leg (C)
				Same width as Work-surface (M)	6" wider than Work-surface (M+6)	12" wider than Work-surface (M+12)		
Freestanding Desk	1	2		1				
Panel-Attached Desk	1	1		1			1 RH	

Return Desk (Attached to a primary or return desk.)

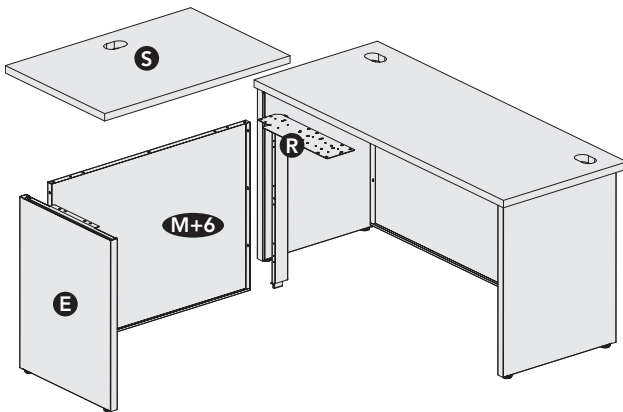

Example Shown		
Qty.	Model	Description
1	T52436S	Flat Edge Worksurface 24"D x 36"W
1	CS429	Modesty Panel 42"W x 29½"H
1	CEP2429F	End-Panel Support 24"D x 29½"H
1	CRK29	Return Kit

Note: The widest modesty panel is 72"W which limits return worksurfaces to a maximum of 66"W.

Return Desk (Attached to a panel-hung worksurface.)

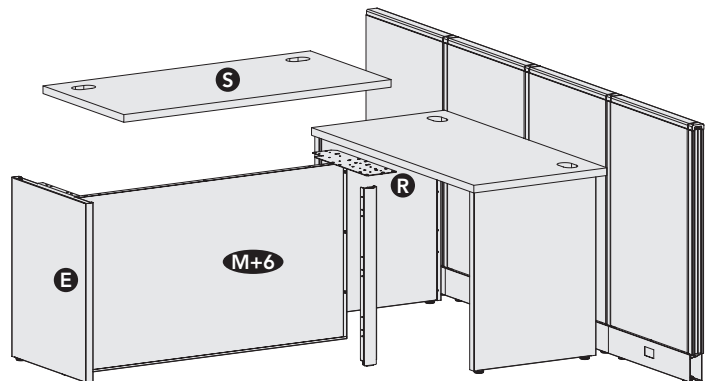

Example Shown		
Qty.	Model	Description
1	T52248S	Flat Edge Worksurface 24"D x 48"W
1	CS549	Modesty Panel 54"W x 29½"H
1	CEP2429F	End-Panel Support 24"D x 29½"H
1	CRK29	Return Kit

CONFIGURATION OPTIONS	Work-surface (S)	End-Panel Support (E)	Desk Support Leg (L)	Modesty Panel			Desk-to-Panel Attachment Kit (D)	Corner Desk Leg (C)	Return Kit (R)
				Same width as Work-surface (M)	6" wider than Work-surface (M+6)	12" wider than Work-surface (M+12)			
Return Desk	1	1			1				1

Configurations

Bridge Desk (Attached between two primary desks.)

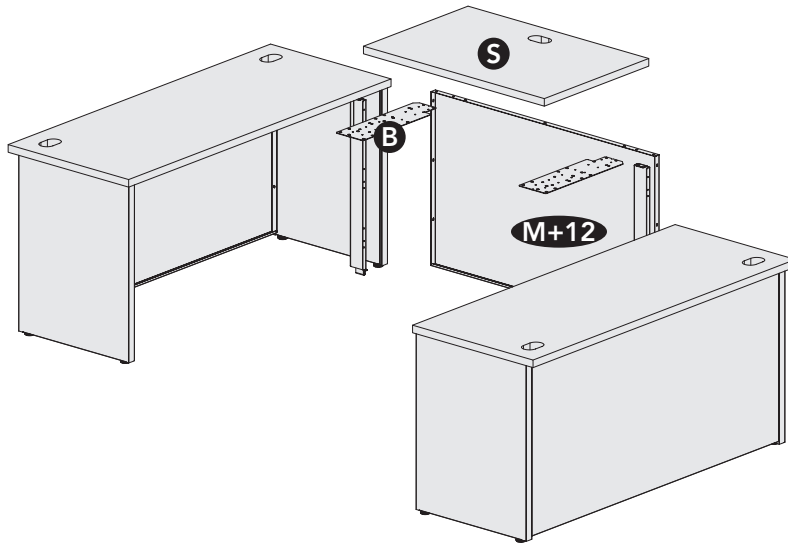

Example Shown

Qty.	Model	Description
1	T52442S	Flat Edge Worksurface 24"D x 42"W
1	CS549	Modesty Panel 54"W x 29½"H
1	CBK29	Bridge Kit

CONFIGURATION	Work-surface (S)	End-Panel Support (E)	Desk Support Leg (L)	Modesty Panel			Desk-to-Panel Attachment Kit (D)	Corner Desk Leg (C)	Bridge Kit (B)
				Same width as Work-surface (M)	6" wider than Work-surface (M+6)	12" wider than Work-surface (M+12)			
Bridge Desk	1					1			1

Bridge Desk and Peninsula (Attached to a primary desk).

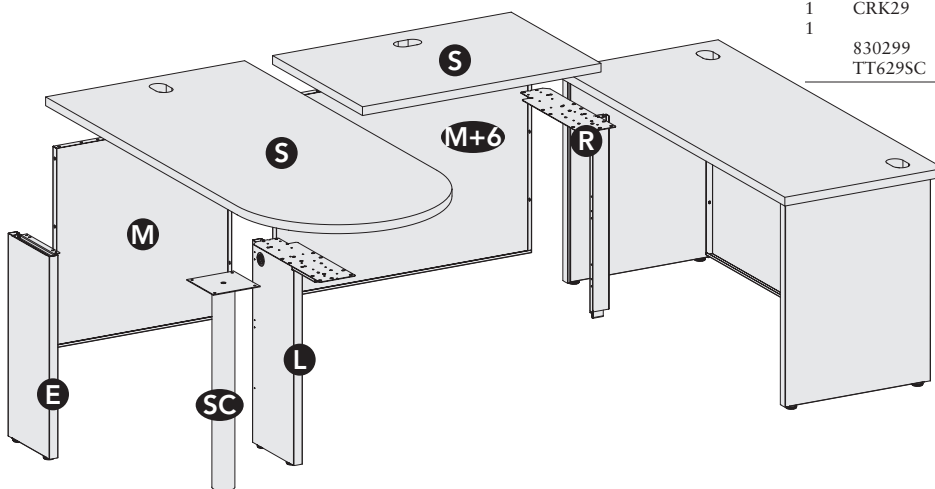

Example Shown

Qty.	Model	Description
1	T52442S	Flat Edge Worksurface 24"D x 42"W
1	T53060B	Flat Edge Peninsula Worksurface 30"W x 60"L
1	CS489	Modesty Panel 48"W x 29½"H
1	CS309	Modesty Panel 30"W x 29½"H
1	CEP1129F	End-Panel Support 11"D x 29½"H
1	CSL2429F	Support Leg 24"D x 29½"H
1	CRK29	Return Kit
1	830299	Support Column for Peninsula Worksurface 29½"H (Concensys)
1	TT629SC	(Optimize™ or Terrace®)

CONFIGURATION OPTION	Work-surface (S)	End-Panel Support (E)	Desk Support Leg (L)	Modesty Panel			Desk-to-Panel Attachment Kit (D)	Support Column (SC)	Return Kit (R)
				Same width as Work-surface (M)	6" wider than Work-surface (M+6)	12" wider than Work-surface (M+12)			
Bridge Desk and Peninsula	2	1	1	1	1			1	1

Configurations

Corner Desk (Stand-alone)

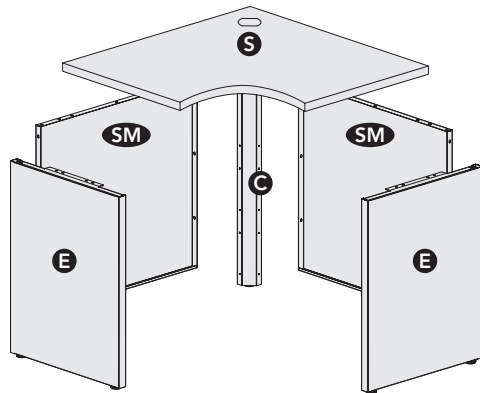

Qty.	Model	Description
1	T53624CR	Flat Edge Worksurface 24"D x 36"W (<i>De-emphasized</i>)
2	CSCMP3629	Stand-Alone Corner Modesty Panel 36"W x 29½"H
2	CEP2429F	End-Panel Support 24"D x 29½"H
1	CDL29	Corner Desk Leg 29½"H

Corner Desk (With an adjacent desk attached at one side.)

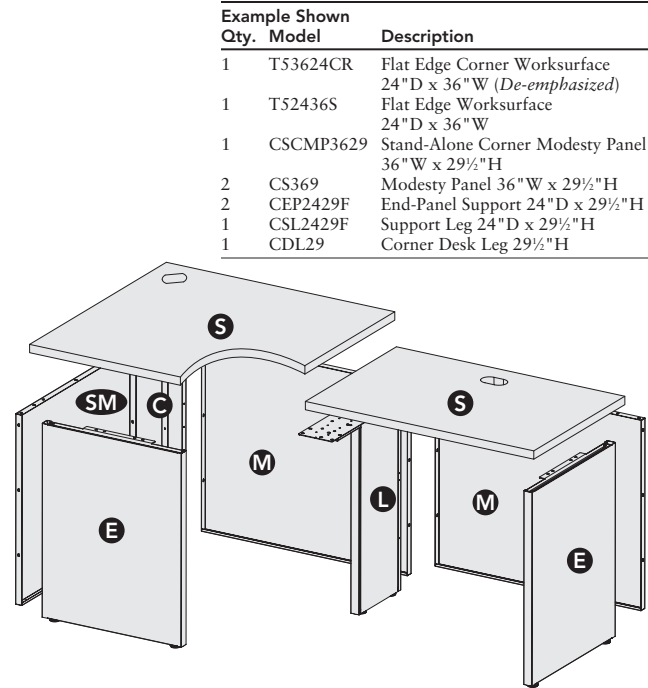

Qty.	Model	Description
1	T53624CR	Flat Edge Corner Worksurface 24"D x 36"W (<i>De-emphasized</i>)
1	T52436S	Flat Edge Worksurface 24"D x 36"W
1	CSCMP3629	Stand-Alone Corner Modesty Panel 36"W x 29½"H
2	CS369	Modesty Panel 36"W x 29½"H
2	CEP2429F	End-Panel Support 24"D x 29½"H
1	CSL2429F	Support Leg 24"D x 29½"H
1	CDL29	Corner Desk Leg 29½"H

CONFIGURATION OPTION	Work-surface (S)	End-Panel Support (E)	Desk Support Leg (L)	Modesty Panel		Stand-Alone Corner Modesty Panel (SM)	Desk-to-Panel Attachment Kit (D)	Corner Desk Leg (C)
				Same width as Work-surface (M)	6" wider than Work-surface (M+6)			
Corner Desk	1	2				2		1
Corner Desk (with adjacent desk)	2	2	1	2		1		1

Bridge Desk (Attached between corner and primary desk.)

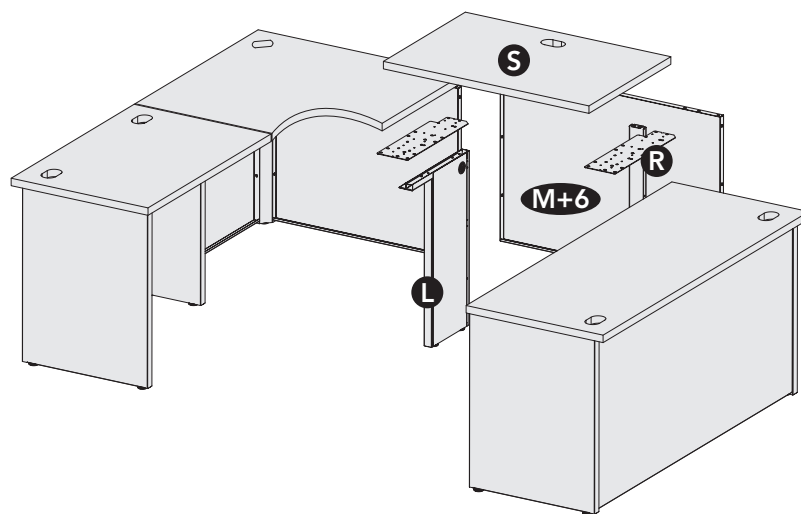

Qty.	Model	Description
1	T52436S	Flat Edge Worksurface 24"D x 36"W
1	CS429	Modesty Panel 42"W x 29½"H
1	CRK29	Return Kit
1	CSL2429F	Support Leg 24"D x 29½"H

CONFIGURATION	Work-surface (S)	End-Panel Support (E)	Desk Support Leg (L)	Modesty Panel			Desk-to-Panel Attachment Kit (D)	Corner Desk Leg (C)	Return Kit (R)
				Same width as Work-surface (M)	6" wider than Work-surface (M+6)	12" wider than Work-surface (M+12)			
Bridge Desk	1		1		1			1	

Configurations

Corner Desk (Attached to a panel with an adjacent desk at one side.)

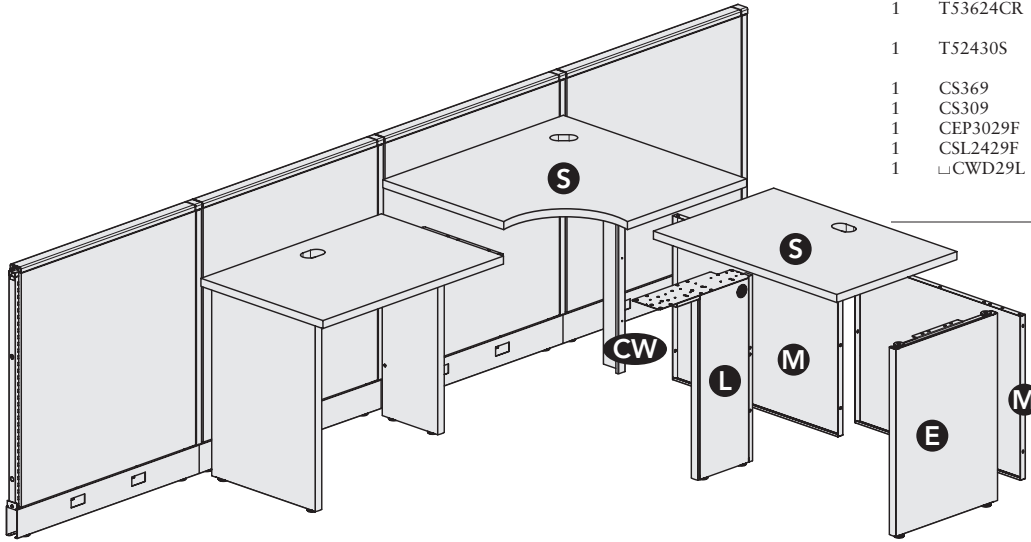

Example Shown		
Qty.	Model	Description
1	T53624CR	Flat Edge Corner Worksurface 36" W x 24" D (<i>De-emphasized</i>)
1	T52430S	Flat Edge Wave Worksurface 24" D x 30" W
1	CS369	Modesty Panel 36" W x 29½" H
1	CS309	Modesty Panel 30" W x 29½" H
1	CEP3029F	End-Panel Support 30" D x 29½" H
1	CSL2429F	Support Leg 24" D x 29½" H
1	□CWD29L	Corner w/Desk Attachment Kit 29" H LH

C – Concensys
TK – Optimize™ or Terrace®

CONFIGURATION	Work-surface (S)	End-Panel Support (E)	Desk Support Leg (L)	Modesty Panel			Desk-to-Panel Attachment Kit (D)	Corner Desk Leg (C)	Corner w/Desk Panel Attachment Kit (CW)
				Same width as Work-surface (M)	6" wider than Work-surface (M+6)	12" wider than Work-surface (M+12)			
Corner Desk	2	1	1	2					1 LH

"U" with Jetty and Corner Cove

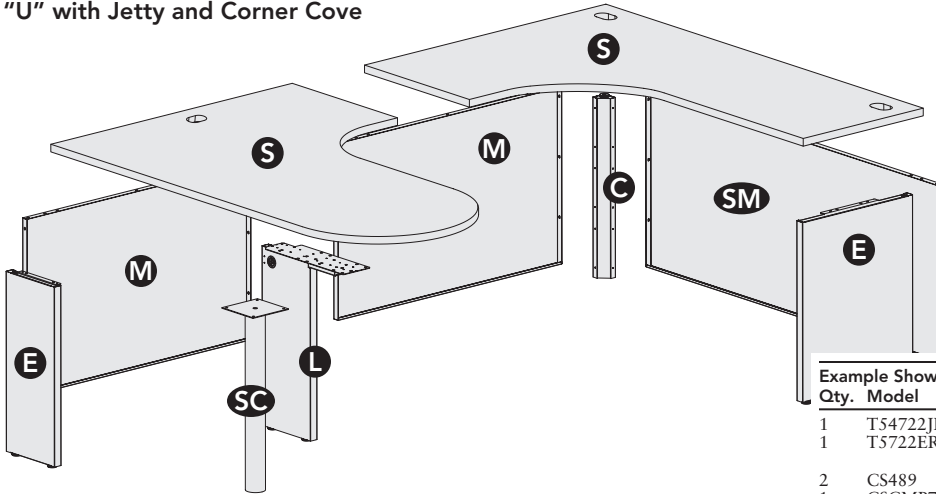

Example Shown		
Qty.	Model	Description
1	T54722JR	Flat Edge Jetty RH 48" D x 72" W x 24" x 30"
1	T5722ER	Flat Edge Corner Cove Extended Right 48" D x 72" W x 24"
2	CS489	Modesty Panel 48" W x 29½" H
1	CSCMP7229	Stand-Alone Corner Modesty Panel 72" W x 29½" H
1	CEP1129F	End-Panel Support 11" D x 29½" H
1	CSL2429F	Support Leg 24" D x 29½" H
1	CEP2429F	Full End-Panel Support 24" D x 29½" H
1	CDL29	Corner Desk Leg 29½" H
1	830299	Support Column for Jetty 29½" H (Concensys)
1	TT629SC	(Optimize or Terrace)

CONFIGURATION OPTION	Work-surface (S)	End-Panel Support (E)	Desk Support Leg (L)	Modesty Panel		Stand-Alone Corner Modesty Panel Same width as Work-surface (SM)	Support Column (SC)	Corner Desk Leg (C)
				Same width as Work-surface (M)	6" wider than Work-surface (M+6)			
Cove and Jetty	2	2	1	2		1	1	1

Cadence Supports

End-Panel Support (page 220)

- End panels are non-handed.
- Freestanding end panel is the same as the Concensys panel-mount end panel except removable panel-mount bracketry not included.
- End panels include attaching hardware and leveling glides.
- Leveling glides provide 2¼" of adjustment.
- End panels are universal, shipped with a left and right-hand attachment bracket.
- End panels cannot be used for in-line junctions and are only used at the end of a panel run.

Support Leg (page 220)

- Support legs are non-handed.
- Freestanding support leg is the same as the Concensys panel-mount support leg except removable panel-mount bracketry not included. Leg portion is 12¾"D.
- Supports junctions of two worksurfaces.
- Includes a flat bracket.
- Concensys in-line support legs are used to support 24"D worksurfaces only in a shared position.

Panel-mount Bracketry (page 220)

- Includes hardware to convert freestanding end panels and support legs to panel-mount.
- Non-handed.

Support Column (page 220)

- Used to support one end of curvilinear worksurfaces.
- Includes panel support brackets.

Permanent-Wall Hanger Kit (page 220)

- Mounts to permanent dry-wall to hang panel-hung components.
- Wall track has ⅛" x ½" slots on 1" centers.
- Customer to furnish connecting hardware. (Refer to Concensys Installation Instructions for appropriate hardware.)
- Worksurfaces should not be supported with cantilever brackets when using permanent-wall hanger kit.
- An integral channel is provided for vertically routing task light cords.
- Includes a cover for top of channel.

Corner Desk Leg (page 220)

- Attaches two modesty panels at rear of corner desk.
- Leveler provides 1½" vertical adjustment.

Bridge Kit (page 220)

- Connects bridge worksurface and modesty panel to end panels and worksurfaces that are perpendicular to the bridge worksurface.
- Includes two flat brackets and two modesty panel-to-end-panel brackets.

Return Kit (page 220)

- Connects return worksurface and modesty panel to end panel and perpendicular worksurface — non-handed.
- Includes one flat bracket and one modesty panel-to-end-panel bracket.

Desk-To-Panel Attachment Kit (page 220)

- Used to connect a worksurface and modesty panel perpendicularly to a Concensys panel of corresponding width. Opposing end of worksurface must be attached with an end-panel, support leg or corner leg mounted directly under this worksurface.
- If using corner or corner cove with the rear corner attached to a panel, and opposing end of worksurface is attached to a freestanding desk — use corner w/desk panel attachment kit
- “Hand” of unit is determined from the user’s side of the desk (left hand unit attaches to left side of modesty).

Corner w/Desk Panel Attachment Kit (page 220)

- Used when the rear corner of a corner or corner cove worksurface and modesty panel is attached to a Concensys panel and opposing end of worksurface is attached to a freestanding desk. Opposing end of worksurface shares the support leg that is mounted under the adjacent freestanding desk.
- “Hand” of unit is determined from the user’s side of the desk.

Flat Brackets (page 220)

- Flat brackets can be used to connect one worksurface perpendicularly to another worksurface.

(continued on next page)

Cadence Supports and Modesty Panels (continued)

Modesty Panel (page 221)

- Mounts to end-panel supports, desk support legs, bridge kit, return kit, desk-to-panel and corner w/desk panel attachment kits.
- 29½"H units provide ¾" of space between bottom of modesty panel and floor.
- Actual width of 29½"H modesty panel is ¾" less than the nominal dimension listed in the Systems Price List.
- 14"H units provide 1¼" of space between bottom of modesty panel and floor.
- Use 14"H modesty panels for desks positioned against a wall to provide access to electrical receptacles.
- 14"H modesty panels, stand-alone corner modesty panels or gussets can now be used with corner or corner cove worksurfaces.
- Refer to pages 201-209 to select proper width.

Stand-alone Corner Modesty Panel (page 221)

- Use only when freestanding one or both sides of a corner or corner cove worksurface.
- Specify width the same as width of worksurface.
- See examples on page 206 on how to specify.
- 29½"H units provide ¾" of spacing between bottom of panel and floor.
- 14"H units provide 1¼" of space between bottom of modesty panel and floor.
- Actual width of modesty panel is 6⅙" less than the nominal dimension listed below.
- Modesty panels are inset 2⅞"; when adding pedestals, consult the chart below.

Gussets (page 221)

- Can be used in place of a modesty panel with desks 36"W to 60"W.
- Provides easy access to wall outlets.
- Can be used with corner desks.
- Cannot be used with suspended pedestals.
- Modesty panels are inset 2⅞"; when adding pedestals, consult the chart below.
- Gussets can be used on corner and corner cove worksurfaces.

Universal Modesty Panel (page 222)

- Mounts under peninsula, p-shape, jetty, and boomerang worksurfaces.
- Can be used with panel-mounted and freestanding worksurfaces.
- Provides 8½" of privacy and is non-handed.
- Constructed of steel. No upcharge for P2 paint.
- Only requires attachment to the worksurface.
- Does not provide electrical, data or structural support.
- Panel is 1½" thick and can be mounted at various distances from edge of worksurface based on user's preference for clearance and conferencing requirements.

Universal Modesty Panels for Concensys Worksurfaces

Model	Peninsula			P-Shape	Jetty		Boomerang
	60"L	66"L	72"L	72"L	66"L	72"L	72"L
PMP41	•						
PMP47		•		•	•		
PMP53			•			•	•

Metal Center Drawers (page 222)

- All metal center drawers feature pencil trays with three compartments for storage.
- For locking specifications, see pages 302-304.
- Ball-bearing slide suspension.

Pedestal Compatibility with Cadence Desking and Systems Worksurfaces

Pedestal Depth	Cadence Freestanding		Systems Panel-hung Worksurfaces	
	24" Deep	30" Deep	24" Deep	30" Deep
18"	Yes	Yes	Yes	Yes
19⅞"	Yes*	Yes	Yes*	Yes
23⅞"		Yes	Yes*	Yes
29⅞"				Yes*

*Wire management grommet is blocked in these applications.

Note: Pedestal placement may affect access to receptacles in base pathway.

Worksurfaces

Concensys® — Primary — Flat Edge

GSA SIN 33721

For specification information see pages 193-200.
For non-standard worksurface sizes see pages 217-218.

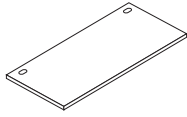

Description	Laminate w/Flat Edge Model	Laminate w/Flat Edge		
		L1 List Price	L2 List Price	L3 List Price
Primary Worksurfaces				
24"W x 20"D	T52024S	\$ 385	\$ 403	\$ 418
30"W x 20"D	T52030S	\$ 408	\$ 427	\$ 442
36"W x 20"D	T52036S	\$ 456	\$ 476	\$ 494
42"W x 20"D	T52042S	\$ 512	\$ 534	\$ 554
48"W x 20"D	T52048S	\$ 553	\$ 576	\$ 597
54"W x 20"D	T52054S	\$ 600	\$ 625	\$ 646
60"W x 20"D	T52060S	\$ 682	\$ 712	\$ 734
66"W x 20"D	T52066S	\$ 739	\$ 771	\$ 795
72"W x 20"D	T52072S	\$ 770	\$ 803	\$ 827
78"W x 20"D	T52078S	\$ 1003	\$ 1044	\$ 1078
84"W x 20"D	T52084S	\$ 1048	\$ 1090	\$ 1126
90"W x 20"D	T52090S	\$ 1239	\$ 1286	\$ 1331
96"W x 20"D	T52096S	\$ 1298	\$ 1347	\$ 1394
24"W x 24"D	T52424S	\$ 407	\$ 426	\$ 441
30"W x 24"D	T52430S	\$ 429	\$ 449	\$ 465
36"W x 24"D	T52436S	\$ 484	\$ 505	\$ 524
42"W x 24"D	T52442S	\$ 540	\$ 562	\$ 583
48"W x 24"D	T52448S	\$ 586	\$ 611	\$ 631
54"W x 24"D	T52454S	\$ 633	\$ 662	\$ 681
60"W x 24"D	T52460S	\$ 718	\$ 749	\$ 771
66"W x 24"D	T52466S	\$ 781	\$ 814	\$ 839
72"W x 24"D	T52472S	\$ 815	\$ 849	\$ 874
78"W x 24"D	T52478S	\$ 1058	\$ 1100	\$ 1136
84"W x 24"D	T52484S	\$ 1109	\$ 1153	\$ 1191
90"W x 24"D	T52490S	\$ 1310	\$ 1359	\$ 1406
96"W x 24"D	T52496S	\$ 1370	\$ 1422	\$ 1472
24"W x 30"D	T53024S	\$ 429	\$ 449	\$ 465
30"W x 30"D	T53030S	\$ 517	\$ 539	\$ 559
36"W x 30"D	T53036S	\$ 556	\$ 579	\$ 600
42"W x 30"D	T53042S	\$ 599	\$ 624	\$ 645
48"W x 30"D	T53048S	\$ 633	\$ 662	\$ 681
54"W x 30"D	T53054S	\$ 707	\$ 738	\$ 760
60"W x 30"D	T53060S	\$ 787	\$ 820	\$ 845
66"W x 30"D	T53066S	\$ 850	\$ 886	\$ 912
72"W x 30"D	T53072S	\$ 922	\$ 960	\$ 989
78"W x 30"D	T53078S	\$ 1197	\$ 1243	\$ 1287
84"W x 30"D	T53084S	\$ 1251	\$ 1298	\$ 1344
90"W x 30"D	T53090S	\$ 1492	\$ 1548	\$ 1603
96"W x 30"D	T53096S	\$ 1540	\$ 1597	\$ 1655



- Notes:**
- 1) Add suffix and upcharge for 24"D and 30"D primary worksurfaces to span a "T" or extended straight connection. Suffix = "TM" for flat edge worksurfaces (Concensys — adds 2 1/4" to width) \$39 upcharge. Examples: T53030STM, T53060STM
 - 2) Add Suffix "N" to model number for no grommet, no upcharge. Example: T53078SN

<p>How to specify — Select the Concensys Model Number from above.</p>	<p>1st Option: Laminate: See page 180 for finishes.</p>	<p>2nd Option: Edge Trim Color: See page 180 for finishes.</p>	<p>3rd Option: Grommet Type (if applicable): P Plastic M Metal (add \$13 per grommet) S Square Metal (Add \$13 per grommet)</p>	<p>4th Option: Grommet Color (Metal only): EL Matte Silver Note: Plastic grommet color matches trim selection.</p>
<p>_____ . _____ . _____ . _____</p>	<p>_____ . _____ . _____ . _____</p>	<p>_____ . _____ . _____ . _____</p>	<p>_____ . _____ . _____ . _____</p>	<p>E L</p>

Examples: T52424S.LM14.EW.P T53048STMN.LM14.E4

[S] Shippable by small-package carrier.

For specification information see pages 193-200.

Laminate

GSA SIN 33721

Description	Laminate w/Flat Edge Model	Laminate w/Flat Edge		
		L1 List Price	L2 List Price	L3 List Price
Bow-Front Worksurfaces				
60"W x 30"D ¹ x 36"D ²	TT53660BT	\$ 1177	\$ 1223	\$ 1266
66"W x 30"D ¹ x 36"D ²	TT53666BT	\$ 1278	\$ 1326	\$ 1372
72"W x 30"D ¹ x 36"D ²	TT53672BT	\$ 1375	\$ 1427	\$ 1477
Note: Add Suffix "N" to model number for no grommet, no upcharge.				
Sample Worksurface				
12"W x 12"D	831212M	\$ 381	\$ 398	\$ 411

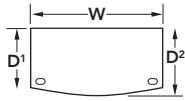
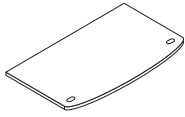

Description	Model	List Price
External Worksurface Support Channel (no color option) — 1 1/2"H		
30"W External Support Channel for use on 42"W Worksurface	Z5SC42 S	\$ 86
36"W External Support Channel for use on 48"W Worksurface	Z5SC48 S	\$ 89
42"W External Support Channel for use on 54"W Worksurface	Z5SC54 S	\$ 102
48"W External Support Channel for use on 60"W Worksurface	Z5SC60	\$ 110
54"W External Support Channel for use on 66"W Worksurface	Z5SC66	\$ 128
60"W External Support Channel for use on 72"W Worksurface	Z5SC72	\$ 137
66"W External Support Channel for use on 78"W Worksurface	Z5SC78	\$ 150
72"W External Support Channel for use on 84"W Worksurface	Z5SC84	\$ 165

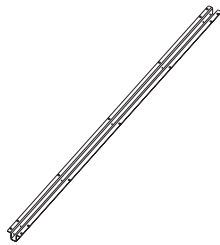

<p>How to specify — Select the Model Number from above.</p>	<p>1st Option: Laminate (if applicable): See page 180 for finishes.</p>	<p>2nd Option: Edge Trim Color (if applicable): See page 180 for finishes.</p>	<p>3rd Option: Grommet Type (if applicable): P Oval Plastic (will match edge trim) M Oval Metal (Add \$13 per grommet) S Square Metal (Add \$13 per grommet)</p>	<p>4th Option: Grommet Color (Metal only) (if applicable): EL Matte Silver Note: Plastic grommet color matches trim selection.</p>
<p>_____ . _____ . _____ . _____</p>	<p>_____ . _____ . _____ . _____</p>	<p>_____ . _____ . _____ . _____</p>	<p>_____ . _____ . _____ . _____</p>	<p>E L</p>

Examples: TT53660BT.LT3B.EV.P 831212M.LT3B.EX.P

Z5SC42

S Shippable by small-package carrier.

Worksurfaces

Concensys® — Corner and Corner Shelf — Flat Edge

For specification information see pages 193-200.

GSA SIN 33721

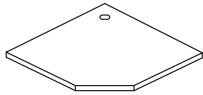
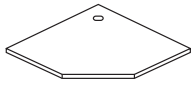

Description	Laminate w/Flat Edge Model	Laminate w/Flat Edge		
		L1 List Price	L2 List Price	L3 List Price
24"D Corner Worksurfaces w/Straight Leading Edge				
36"W	T53624SC	\$ 715	\$ 746	\$ 775
42"W	T54224SC	\$ 754	\$ 786	\$ 816
48"W	T54824SC	\$ 853	\$ 889	\$ 925
30"D Corner Worksurfaces w/Straight Leading Edge				
42"W	T54230SC	\$ 932	\$ 972	\$ 1010
48"W	T54830SC	\$ 964	\$ 1005	\$ 1044

Note: Add Suffix "N" to model number for no grommet, no upcharge.

Corner Worksurfaces with Radial Leading Edge

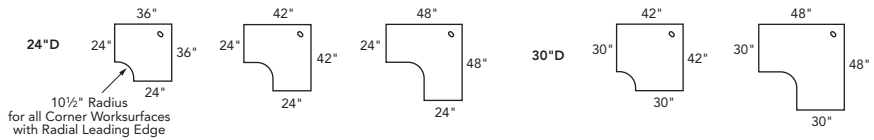

Corner Worksurfaces with Straight Leading Edge

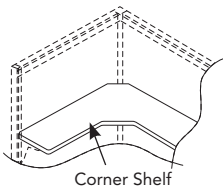
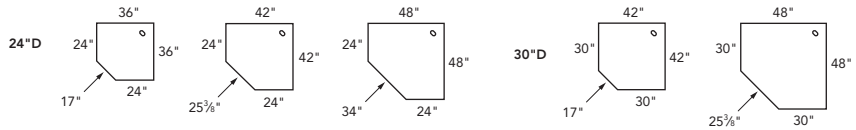

Description	Model	P1 List Price			P2 List Price		
		L1	L2	L3	L1	L2	L3
Corner Shelves with Flat Edge							
36" x 36" x 11"D	860536M	\$ 734	\$ 764	\$ 784	\$ 734	\$ 764	\$ 784
42" x 42" x 11"D	860542M	\$ 779	\$ 810	\$ 832	\$ 779	\$ 810	\$ 832
48" x 48" x 11"D	860548M	\$ 828	\$ 860	\$ 885	\$ 828	\$ 860	\$ 885

<p>How to specify — Select the Model Number from above.</p>	<p>1st Option: Laminate: See page 180 for finishes.</p>	<p>2nd Option: Paint (Corner Shelves only): P1 P2 See page 180 for finishes.</p>	<p>2nd Option: Edge Trim Color: See page 180 for finishes.</p>	<p>3rd Option: Grommet Type (Corner Worksurfaces only): P Plastic M Metal (add \$13 per grommet) S Square Metal (Add \$13 per grommet)</p>	<p>4th Option: Grommet Color (Metal only): EL Matte Silver Note: Plastic grommet color matches trim selection.</p>
<p>_____ .</p>	<p>_____ .</p>	<p>P </p>	<p>_____ .</p>	<p> </p>	<p>E L </p>

Examples: T53624SC.LT3B.EV.MEL 860536M.LT3B.P27.E4

For specification information see pages 193-200.

GSA SIN 33721

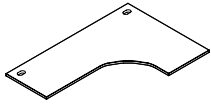

Description	Laminate w/Flat Edge Model	Laminate w/Flat Edge		
		L1 List Price	L2 List Price	L3 List Price
Corner Cove Worksurfaces — Extended Left				
60" x 36" — 24"L / 24"R	T5822EL	\$ 856	\$ 894	\$ 927
60" x 36" — 24"L / 30"R	T5832EL	\$ 897	\$ 937	\$ 970
60" x 48" — 24"L / 24"R	T5622EL	\$ 959	\$ 1001	\$ 1036
60" x 48" — 30"L / 24"R	T5623EL	\$ 1004	\$ 1047	\$ 1085
60" x 48" — 24"L / 30"R	T5632EL	\$ 1004	\$ 1047	\$ 1085
60" x 48" — 30"L / 30"R	T5633EL	\$ 1041	\$ 1085	\$ 1125
72" x 36" — 24"L / 24"R	T5922EL	\$ 959	\$ 1001	\$ 1036
72" x 36" — 24"L / 30"R	T5932EL	\$ 1004	\$ 1047	\$ 1085
72" x 48" — 24"L / 24"R	T5722EL	\$ 1243	\$ 1292	\$ 1339
72" x 48" — 30"L / 24"R	T5723EL	\$ 1288	\$ 1338	\$ 1390
72" x 48" — 24"L / 30"R	T5732EL	\$ 1288	\$ 1338	\$ 1390
72" x 48" — 30"L / 30"R	T5733EL	\$ 1326	\$ 1379	\$ 1432

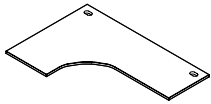

Corner Cove Worksurfaces — Extended Right				
36" x 60" — 24"L / 24"R	T5822ER	\$ 856	\$ 894	\$ 927
36" x 60" — 30"L / 24"R	T5832ER	\$ 897	\$ 937	\$ 970
48" x 60" — 24"L / 24"R	T5622ER	\$ 959	\$ 1001	\$ 1036
48" x 60" — 24"L / 30"R	T5623ER	\$ 1004	\$ 1047	\$ 1085
48" x 60" — 30"L / 24"R	T5632ER	\$ 1004	\$ 1047	\$ 1085
48" x 60" — 30"L / 30"R	T5633ER	\$ 1041	\$ 1085	\$ 1125
36" x 72" — 24"L / 24"R	T5922ER	\$ 959	\$ 1001	\$ 1036
36" x 72" — 30"L / 24"R	T5932ER	\$ 1004	\$ 1047	\$ 1085
48" x 72" — 24"L / 24"R	T5722ER	\$ 1243	\$ 1292	\$ 1339
48" x 72" — 24"L / 30"R	T5723ER	\$ 1288	\$ 1338	\$ 1390
48" x 72" — 30"L / 24"R	T5732ER	\$ 1288	\$ 1338	\$ 1390
48" x 72" — 30"L / 30"R	T5733ER	\$ 1326	\$ 1379	\$ 1432

Note: Add Suffix "N" to model number for no grommet, no upcharge.

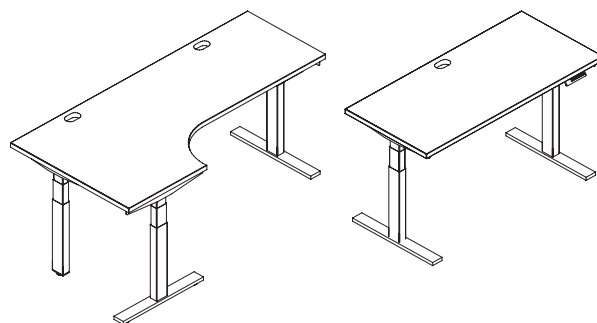

Note: Freestanding Altitude electric height-adjustable tables are available to order in Seating, Collaboration, and Tables price list.

<p>How to specify — Select the Model Number from above.</p>	<p>1st Option: Laminate: See page 180 for finishes.</p>	<p>2nd Option: Edge Trim Color: See page 180 for finishes.</p>	<p>3rd Option: Grommet Type: P Oval Plastic (will match edge trim) M Oval Metal (Add \$13 per grommet) S Square Metal (Add \$13 per grommet)</p>	<p>4th Option: Grommet Color (Metal only): EL Matte Silver Note: Plastic grommet color matches trim selection.</p>
<p>_____ .</p>	<p>_____ .</p>	<p>_____ .</p>	<p>_____</p>	<p>E L</p>

Examples: T5822EL.LT3B.EY.MEL T5822EL.LT3B.EV.P

Worksurfaces

Concensys® — Peninsula / P-Shaped / Jetty / — Flat Edge

For specification information see pages 193-200.

GSA SIN 33721

Support column ordered separately.

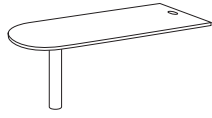

Description	Laminate w/Flat Edge Model	Laminate w/Flat Edge		
		L1 List Price	L2 List Price	L3 List Price
Peninsula Worksurfaces				
60"L x 30"W	T53060B	\$ 1077	\$ 1120	\$ 1158
66"L x 30"W	T53066B	\$ 1190	\$ 1236	\$ 1280
72"L x 30"W	T53072B	\$ 1298	\$ 1347	\$ 1394
<hr/>				
60"L x 36"W	T53660B	\$ 796	\$ 845	\$ 892
66"L x 36"W	T53666B	\$ 853	\$ 907	\$ 961
72"L x 36"W	T53672B	\$ 964	\$ 1022	\$ 1084

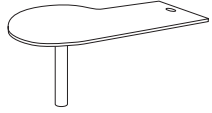

P-Shaped Worksurfaces w/42" Diameter End				
72"L x 30"W (Left hand)	T53072PR	\$ 1488	\$ 1544	\$ 1600
72"L x 30"W (Right hand)	T53072PL	\$ 1488	\$ 1544	\$ 1600



Jetty Worksurfaces — Left Hand				
48"A x 66"B x 24"C x 30"D	T54662JL	\$ 1243	\$ 1296	\$ 1349
48"A x 72"B x 24"C x 30"D	T54722JL	\$ 1326	\$ 1379	\$ 1433
48"A x 66"B x 30"C x 30"D	T54663JL	\$ 1288	\$ 1342	\$ 1397
48"A x 72"B x 30"C x 30"D	T54723JL	\$ 897	\$ 953	\$ 1009

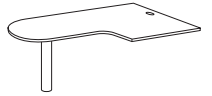

Jetty Worksurfaces — Right Hand				
48"A x 66"B x 24"C x 30"D	T54662JR	\$ 1243	\$ 1296	\$ 1349
48"A x 72"B x 24"C x 30"D	T54722JR	\$ 1326	\$ 1379	\$ 1433
48"A x 66"B x 30"C x 30"D	T54663JR	\$ 1288	\$ 1342	\$ 1397
48"A x 72"B x 30"C x 30"D	T54723JR	\$ 897	\$ 953	\$ 1009

Note: Add Suffix "N" to model number for no grommet, no upcharge.

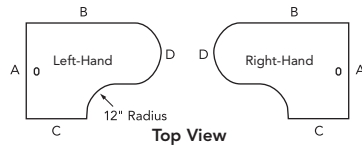

<p>How to specify — Select the Model Number from above.</p>	<p>1st Option: Laminate: See page 180 for finishes.</p>	<p>2nd Option: Edge Trim Color: See page 180 for finishes.</p>	<p>3rd Option: Grommet Type: P Oval Plastic (will match edge trim) M Oval Metal (Add \$13 per grommet) S Square Metal (Add \$13 per grommet)</p>	<p>4th Option: Grommet Color (Metal only): EL Matte Silver Note: Plastic grommet color matches trim selection.</p>
<p>_____ .</p>	<p>_____ .</p>	<p>_____ .</p>	<p>_____</p>	<p>E L</p>

Examples: T53060B.LT3B.EV.P T54662JL.LT3B.EV.MEL

Worksurfaces

Concensys® — Countertops — Flat Edge

For specification information see pages 193-200.

GSA SIN 33721

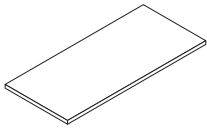

Description	Model	List Price		
		L1	L2	L3
Straight Countertops — must order 2 sets of brackets per surface				
24"W x 15"D	851524M	\$ 387	\$ 405	\$ 418
30"W x 15"D	851530M	\$ 429	\$ 448	\$ 462
36"W x 15"D	851536M	\$ 482	\$ 502	\$ 519
42"W x 15"D	851542M	\$ 499	\$ 519	\$ 537
48"W x 15"D	851548M	\$ 528	\$ 549	\$ 568
54"W x 15"D	851554M	\$ 598	\$ 621	\$ 641
60"W x 15"D	851560M	\$ 667	\$ 687	\$ 704
66"W x 15"D	851566M	\$ 691	\$ 720	\$ 739
72"W x 15"D	851572M	\$ 718	\$ 748	\$ 767



Corner Countertops — must order 3 sets of brackets per surface				
15"D x 24"W x 24"W	852424M	\$ 754	\$ 785	\$ 806
15"D x 30"W x 30"W	853030M	\$ 877	\$ 911	\$ 936
15"D x 36"W x 36"W	853636M	\$ 973	\$ 1010	\$ 1039
15"D x 42"W x 42"W	854242M	\$ 1056	\$ 1096	\$ 1129

OPTIONS:

SUFFIX	OPTION — Routed to fit Painted Variable Height Trim	UPCHARGE
RS	For routing one end of a straight countertop, when used in variable height panel applications.	None
RR*	For routing right end of corner countertops, when used in variable height panel applications.	None
RL*	For routing left end of corner countertops, when used in variable height panel applications.	None
RB*	For routing both ends of a straight or corner countertop when used in variable height panel applications.	None

**Note: "Right end" and "left end" are determined by facing the inside radius of the corner countertop.*

<p>How to specify — Select the Concensys Model Number from above.</p>	<p>1st Option: Laminate (Countertops only): See page 180 for finishes.</p>	<p>1st Option: Paint (for Brackets only): P1 P2 P3 See page 180 for finishes.</p>	<p>2nd Option: Edge Trim Color (Countertops only): See page 180 for finishes.</p>
<p>8 5 .</p>	<p> .</p>	<p> .</p>	<p> </p>

Example: 851524M.LT3B.EX

ORDERING

The 9120 Program can be used to order particle board rectangular worksurfaces in any non-standard width and depth in 1/8" increments up to a maximum of 120" W x 36" D.

Specify:

1. **Model Number**
Specify closest nominal width/depth model (round up).
2. **Grommet Option** (if desired)
See grommet specification instructions on this page.
3. **Grommet Type:**
P Plastic
M Metal (add \$13 per grommet for laminate)
4. **Grommet Color:**
(Metal only)
EL Matte Silver
NOTE: Plastic grommet will match flat edge.
5. **Laminate Choices**
See page 180.
6. **Flat Edge Color Choices**
See EDGE COLORS page 180 for laminates.
7. **Exact Size**

Specify the **EXACT Width** and **EXACT Depth** you require. Width and depth is specified in 1/8" increments which is denoted as a single digit following the whole number dimension at the end of the model number string.

1/8" = 1	5/8" = 5
2/8" = 2	6/8" = 6
3/8" = 3	7/8" = 7
4/8" = 4	no extra increment = 0

For example, when ordering a worksurface that is 34 3/8" W x 20 1/2" D, specification should be 345Wx204D.

Example: 9120R3624.G0.TM33.EU.345Wx204D.

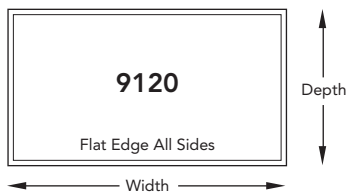

PRODUCT SPECIFICATIONS

- Flat Edge on all sides
- 45 lb. particle board
- 1 1/8" top thickness
- .020 resin impregnated paper backer sheet
- Grommets available
- Maximum width 120" (maximum recommended unsupported span is 42")
- Maximum depth 36"
- Standard Allsteel laminates
- Quantities of 10 or greater are palletized; less than 10 are individually cartoned.

Note: 9120 worksurface maximum unsupported span is 42". 9120 worksurfaces do not have pre-drilled pilot holes or threaded metal inserts.

When spanning multiple freestanding storage units with one worksurface, add 1/8" for each additional storage unit. For example, when ordering a worksurface for three 30"W lateral files. 3 units x 30" = 90" + 1/8" + 1/8" = 90 1/4" worksurface. Do NOT follow this rule if panel wrapping storage units.

CHANGES / CANCELLATIONS

No changes/cancellations for 9120 Program Worksurfaces.

GROMMET SPECIFICATIONS

Plastic grommets are made of durable ABS plastic and grommets match edge color on laminate worksurfaces. Metal grommets are only available Matte Silver oval for laminate.

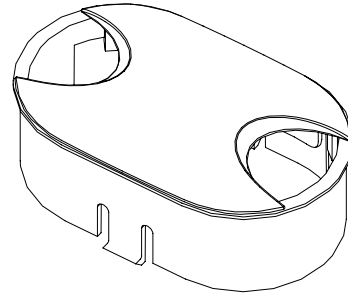

PRICING

One Grommet – GC, GL, or GR Position \$20.00
 Two Grommets – G3 or G4 Position..... \$40.00
NOTE: Add \$13 per grommet for Metal grommets with laminate.

ORDERING

Specify grommet location and color.
 Example: 9120R10836.GCP.TM33.EU.1022Wx326D

Code Grommet Position

- GC Centered side-to-side – 3/8" from rear to grommet edge; 4 1/2" from rear to grommet center
- GL 6 1/16" from left side to grommet edge – 3/8" from rear to grommet edge; 4 1/2" from rear to grommet center
- GR 6 1/16" from right side to grommet edge – 3/8" from rear to grommet edge; 4 1/2" from rear to grommet center
- G3 Pair of grommets each 18" from side edge – 3/8" from rear to grommet edge; 4 1/2" from rear to grommet center (Position G3 not available on tops 60"W or less.)
- G4 Pair of grommets each 6 1/16" from side edge to grommet edge – 3/8" from rear to grommet edge; 4 1/2" from rear to grommet center
- G0 No grommets

Dimensions are from grommet center line to top edge.

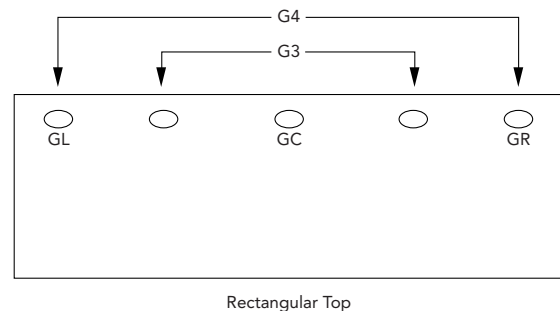

Grommet positions other than those shown above are considered non-standard.

Worksurfaces

9120 Program

For specification information see page 217.

Laminate Worksurfaces / Non-Standard Sizes

GSA SIN 33721

Maximum	Model Number*	Width		Depth		Laminate List Price		
		MIN	MAX	MIN	MAX	L1	L2	L3
18"D								
18"W	9120R1818	180W	180W	121D	180D	\$ 468	\$ 489	\$ 506
24"W	9120R2418	181W	240W	121D	180D	\$ 489	\$ 510	\$ 529
30"W	9120R3018	241W	300W	121D	180D	\$ 535	\$ 557	\$ 576
36"W	9120R3618	301W	360W	121D	180D	\$ 556	\$ 579	\$ 600
42"W	9120R4218	361W	420W	121D	180D	\$ 643	\$ 668	\$ 690
48"W	9120R4818	421W	480W	121D	180D	\$ 709	\$ 740	\$ 762
60"W	9120R6018	481W	600W	121D	180D	\$ 925	\$ 962	\$ 990
72"W	9120R7218	601W	720W	121D	180D	\$ 1119	\$ 1161	\$ 1198
84"W	9120R8418	721W	840W	121D	180D	\$ 1463	\$ 1515	\$ 1569
96"W	9120R9618	841W	960W	121D	180D	\$ 1513	\$ 1567	\$ 1621
108"W	9120R10818	961W	1080W	121D	180D	\$ 1730	\$ 1790	\$ 1853
120"W	9120R12018	1081W	1200W	121D	180D	\$ 1877	\$ 1948	\$ 2018
24"D								
24"W	9120R2424	181W	240W	181D	240D	\$ 531	\$ 553	\$ 574
30"W	9120R3024	241W	300W	181D	240D	\$ 580	\$ 603	\$ 624
36"W	9120R3624	301W	360W	181D	240D	\$ 605	\$ 630	\$ 651
42"W	9120R4224	361W	420W	181D	240D	\$ 695	\$ 725	\$ 744
48"W	9120R4824	421W	480W	181D	240D	\$ 750	\$ 782	\$ 806
60"W	9120R6024	481W	600W	181D	240D	\$ 971	\$ 1009	\$ 1042
72"W	9120R7224	601W	720W	181D	240D	\$ 1162	\$ 1206	\$ 1244
84"W	9120R8424	721W	840W	181D	240D	\$ 1513	\$ 1567	\$ 1621
96"W	9120R9624	841W	960W	181D	240D	\$ 1488	\$ 1544	\$ 1600
108"W	9120R10824	961W	1080W	181D	240D	\$ 1780	\$ 1842	\$ 1907
120"W	9120R12024	1081W	1200W	181D	240D	\$ 1920	\$ 1992	\$ 2065
30"D								
30"W	9120R3030	241W	300W	241D	300D	\$ 638	\$ 667	\$ 686
36"W	9120R3630	301W	360W	241D	300D	\$ 671	\$ 701	\$ 721
42"W	9120R4230	361W	420W	241D	300D	\$ 715	\$ 746	\$ 768
48"W	9120R4830	421W	480W	241D	300D	\$ 774	\$ 807	\$ 832
60"W	9120R6030	481W	600W	241D	300D	\$ 1016	\$ 1056	\$ 1089
72"W	9120R7230	601W	720W	241D	300D	\$ 1161	\$ 1206	\$ 1247
84"W	9120R8430	721W	840W	241D	300D	\$ 1763	\$ 1828	\$ 1894
96"W	9120R9630	841W	960W	241D	300D	\$ 1805	\$ 1871	\$ 1939
108"W	9120R10830	961W	1080W	241D	300D	\$ 2033	\$ 2108	\$ 2186
120"W	9120R12030	1081W	1200W	241D	300D	\$ 2265	\$ 2350	\$ 2434
36"D								
36"W	9120R3636	301W	360W	301D	360D	\$ 911	\$ 948	\$ 978
42"W	9120R4236	361W	420W	301D	360D	\$ 1035	\$ 1077	\$ 1112
48"W	9120R4836	421W	480W	301D	360D	\$ 1163	\$ 1208	\$ 1249
60"W	9120R6036	481W	600W	301D	360D	\$ 1498	\$ 1551	\$ 1605
72"W	9120R7236	601W	720W	301D	360D	\$ 1764	\$ 1826	\$ 1889
84"W	9120R8436	721W	840W	301D	360D	\$ 2135	\$ 2210	\$ 2288
96"W	9120R9636	841W	960W	301D	360D	\$ 2188	\$ 2266	\$ 2343
108"W	9120R10836	961W	1080W	301D	360D	\$ 2426	\$ 2512	\$ 2601
120"W	9120R12036	1081W	1200W	301D	360D	\$ 2538	\$ 2632	\$ 2729

For specification information see pages 193-200.

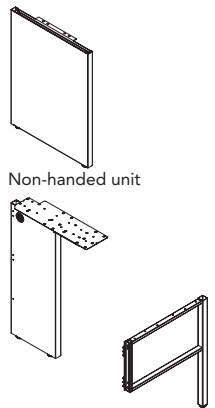

Description	Model	P1 Paint List Price	P2 Paint List Price	P3 Paint List Price
End-Panel Supports				
11"D x 29½"H Panel-Mount	CEP1129P S	\$ 312	\$ 354	\$ 395
24"D x 29½"H Panel-Mount	CEP2429P S	\$ 333	\$ 375	\$ 416
30"D x 29½"H Panel-Mount	CEP3029P S	\$ 365	\$ 407	\$ 448

Support Legs				
24"D x 29½"H Panel-Mount	CSL2429P S	\$ 294	\$ 336	\$ 377
30"D x 29½"H Panel-Mount	CSL3029P S	\$ 321	\$ 363	\$ 404

Concensys Open End Panel Supports				
12"D x 29½"H Panel-Mount	ACBHEP1229 S	\$ 314	\$ 357	\$ 399
24"D x 29½"H Panel-Mount	ACBHEP2429 S	\$ 331	\$ 374	\$ 416
30"D x 29½"H Panel-Mount	ACBHEP3029 S	\$ 361	\$ 404	\$ 446

Cantilever Bracket — Concensys				
12"D Left-Hand	CCB12L S	\$ 82	\$ 99	\$ 111
12"D Right-Hand	CCB12R S	\$ 82	\$ 99	\$ 111
18"D Left-Hand	CCB18L S	\$ 77	\$ 94	\$ 106
18"D Right-Hand	CCB18R S	\$ 77	\$ 94	\$ 106
24" or 30"D Left-Hand	CCB24L S	\$ 92	\$ 109	\$ 121
24" or 30"D Right-Hand	CCB24R S	\$ 92	\$ 109	\$ 121

Universal Cantilever				
24" or 30"D	T624CB S	\$ 228	\$ 237	\$ 245

Worksurface-to-Panel Brackets				
24"D	831324 S	\$ 108	\$ 124	\$ 136
30"D	831330 S	\$ 108	\$ 124	\$ 136

Worksurface Bracket Kit				
One Pair	831099 S	\$ 79	\$ 95	\$ 107

Flat Brackets				
12"D	T612FB S	\$ 70	N/A	N/A
24"D	831124 S	\$ 79	N/A	N/A
30"D	831130 S	\$ 86	N/A	N/A

Note: Flint only.

<p>How to specify — Select the Concensys Model Number from above.</p>	<p><i>1st Option:</i> Paint (if applicable): P1 P2 P3 See page 180 for finishes.</p>
<p>_____ .</p>	<p>P _____</p>

Examples: CEP1129P.P28 831324.P28 831124

S Shippable by small-package carrier.

Cadence® Freestanding

Concensys® — Freestanding Components

For specification information see pages 201-209.

GSA SIN 33721

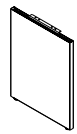

Factory-configured as non-handed unit.

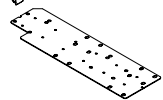
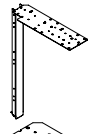
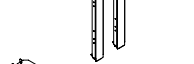
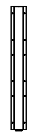
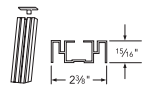
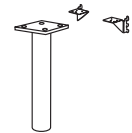
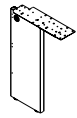

Description	Model	P1 Paint List Price	P2 Paint List Price	P3 Paint List Price
End-Panel Supports				
11"D x 29½"H – Freestanding	CEP1129F	\$ 277	\$ 319	\$ 360
24"D x 29½"H – Freestanding	CEP2429F	\$ 297	\$ 339	\$ 380
30"D x 29½"H – Freestanding	CEP3029F	\$ 329	\$ 371	\$ 412
<hr/>				
11"D x 29½"H – Panel-Mount	CEP1129P	\$ 312	\$ 354	\$ 395
24"D x 29½"H – Panel-Mount	CEP2429P	\$ 333	\$ 375	\$ 416
30"D x 29½"H – Panel-Mount	CEP3029P	\$ 365	\$ 407	\$ 448
GSA — Above pricing reflects systems furniture pricing schedule.				
Support Legs				
24"D x 29½"H – Freestanding	CSL2429F	\$ 257	\$ 299	\$ 340
30"D x 29½"H – Freestanding	CSL3029F	\$ 285	\$ 327	\$ 368
<hr/>				
24"D x 29½"H – Panel-Mount	CSL2429P	\$ 294	\$ 336	\$ 377
30"D x 29½"H – Panel-Mount	CSL3029P	\$ 321	\$ 363	\$ 404
GSA — Above pricing reflects systems furniture pricing schedule.				
Panel-Mount End-Panel/Support Leg Bracketry				
29½"H	CPMB29	\$ 64	\$ 81	\$ 93
<hr/>				
Support Columns				
For 29½" Height, 3" Diameter	830299	\$ 271	\$ 312	\$ 352
<hr/>				
Concensys Permanent-Wall Hanger Kit				
One Pair (Double Wall Track) 2⅜"W x 1⅝"D x 65¼"L	801550	\$ 198	\$ 225	\$ 248
Note: Anchor devices are not supplied with this model.				
<hr/>				
Corner Desk Leg				
29½"H	CDL29	\$ 236	\$ 261	\$ 283
<hr/>				
Bridge Kit				
29½"H	CBK29	\$ 248	\$ 265	\$ 277
<hr/>				
Return Kit				
29½"H	CRK29	\$ 127	\$ 140	\$ 149
<hr/>				
Flat Brackets				
24"D	831124	\$ 79	N/A	N/A
30"D	831130	\$ 86	N/A	N/A
Note: Flint only.				

How to specify —
Select the Concensys Model Number from above.

1st Option:
Paint (if applicable):
 See page 180 for finishes.

Examples: CEP1129F.P28 831124

Shippable by small-package carrier.

For specification information see pages 201-209.

GSA SIN 33721

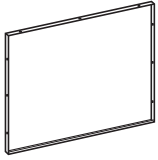

Description	Model	P1 Paint List Price	P2 Paint List Price	P3 Paint List Price
Modesty Panels				
29½"H x 24"W	CS249 S	\$ 268	\$ 293	\$ 315
29½"H x 30"W	CS309 S	\$ 277	\$ 302	\$ 324
29½"H x 36"W	CS369 S	\$ 283	\$ 308	\$ 330
29½"H x 42"W	CS429 S	\$ 289	\$ 314	\$ 336
29½"H x 48"W	CS489 S	\$ 294	\$ 319	\$ 341
29½"H x 54"W	CS549 S	\$ 297	\$ 322	\$ 344
29½"H x 60"W	CS609	\$ 302	\$ 327	\$ 349
29½"H x 66"W	CS669	\$ 307	\$ 332	\$ 354
29½"H x 72"W	CS729	\$ 319	\$ 344	\$ 366

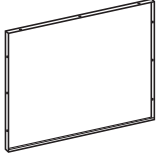

Stand-alone Corner Modesty Panels				
29½"H x 36"W	CSCMP3629 S	\$ 283	\$ 308	\$ 330
29½"H x 42"W	CSCMP4229 S	\$ 289	\$ 314	\$ 336
29½"H x 48"W	CSCMP4829 S	\$ 294	\$ 319	\$ 341
29½"H x 60"W	CSCMP6029	\$ 302	\$ 327	\$ 349
29½"H x 72"W	CSCMP7229	\$ 319	\$ 344	\$ 366

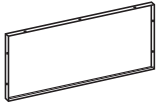

Modesty Panels				
14"H x 24"W	CS244 S	\$ 253	\$ 278	\$ 300
14"H x 30"W	CS304 S	\$ 258	\$ 283	\$ 305
14"H x 36"W	CS364 S	\$ 265	\$ 290	\$ 312
14"H x 42"W	CS424 S	\$ 272	\$ 297	\$ 319
14"H x 48"W	CS484 S	\$ 282	\$ 307	\$ 329
14"H x 54"W	CS544 S	\$ 285	\$ 310	\$ 332
14"H x 60"W	CS604	\$ 294	\$ 319	\$ 341
14"H x 66"W	CS664	\$ 297	\$ 322	\$ 344
14"H x 72"W	CS724	\$ 302	\$ 327	\$ 349

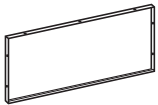

Stand-alone Corner Modesty Panels				
14"H x 36"W	CSCMP3614 S	\$ 265	\$ 290	\$ 312
14"H x 42"W	CSCMP4214 S	\$ 272	\$ 297	\$ 319
14"H x 48"W	CSCMP4814 S	\$ 282	\$ 307	\$ 329
14"H x 60"W	CSCMP6014	\$ 294	\$ 319	\$ 341
14"H x 72"W	CSCMP7214	\$ 302	\$ 327	\$ 349



Gussets				
One pair	CDG S	\$ 193	\$ 218	\$ 240

How to specify —
Select the Concensys Model Number from above.

1st Option:
Paint:
P1 P2 P3
 See page 180 for finishes.

C | | | | | | | | | | . P | | | | |

Examples: CS249.PR3 CS244.P28

S Shippable by small-package carrier.

Cadence® Freestanding

Concensys® — Universal Modesty Panels

For specification information see pages 201-209.

GSA SIN 33721

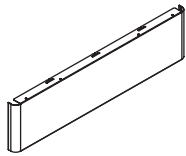

Description	Model	List Price
Modesty Panels		
41"W	PMP41 S	\$ 371
47"W	PMP47 S	\$ 379
53"W	PMP53 S	\$ 391

Universal Modesty Panels for Concensys Worksurfaces							
	Peninsula			P-Shape	Jetty		Boomerang
Model	60"L	66"L	72"L	72"L	66"L	72"L	72"L
PMP41	•						
PMP47		•		•	•		
PMP53			•			•	•

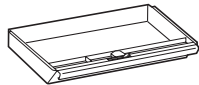

Angled front

Description	Model	P1 Paint List Price	P2 Paint List Price	P3 Paint List Price
Metal Center Drawer w/Lock				
19"W x 14¼"D x 3"H	CSDC19 S	\$ 305	\$ 327	\$ 346
<ul style="list-style-type: none"> • 12" drawer extension (3/4). • Inside drawer dimension: 19"W x 13"D x 2⅞"H. • Minimum clearance for mounting: 21¼"W x 19¼"D. 				

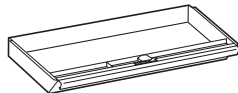

Angled front

24½"W x 14¼"D x 3"H	CSDC25 S	\$ 314	\$ 336	\$ 355
<ul style="list-style-type: none"> • 12" drawer extension (3/4). • Inside drawer dimension: 24½"W x 13½"D x 2⅞"H. • Minimum clearance for mounting: 27⅞"W x 19¼"D. 				

<p>How to specify — Select the Concensys Model Number from above.</p> <p>_____ .</p>	<p>1st Option: Paint: P1 P2 P3 See page 180 for finishes.</p> <p>P </p>	<p>2nd Option: Lock (if applicable): STD Standard — Random Keyed OMT Omit Lock Core (Deduct \$20 per lock)</p> <p> </p>
---	---	---

Examples: PMP41.P27 CSDC19.P28.STD

S Shippable by small-package carrier.

Overhead Storage Cabinets

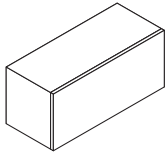

Square Flipper Door

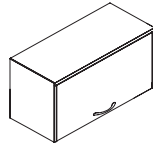

Receding Door with Recessed Pull

Open Bookshelf

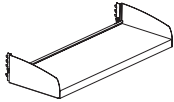

Hutch

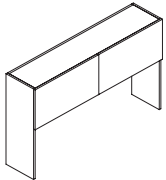

Square Flipper Door

Overheads & Shelves

Overhead storage components maximize the use of space in the workstation and also provide convenient access to binders, reference materials, software packages, and miscellaneous supplies.

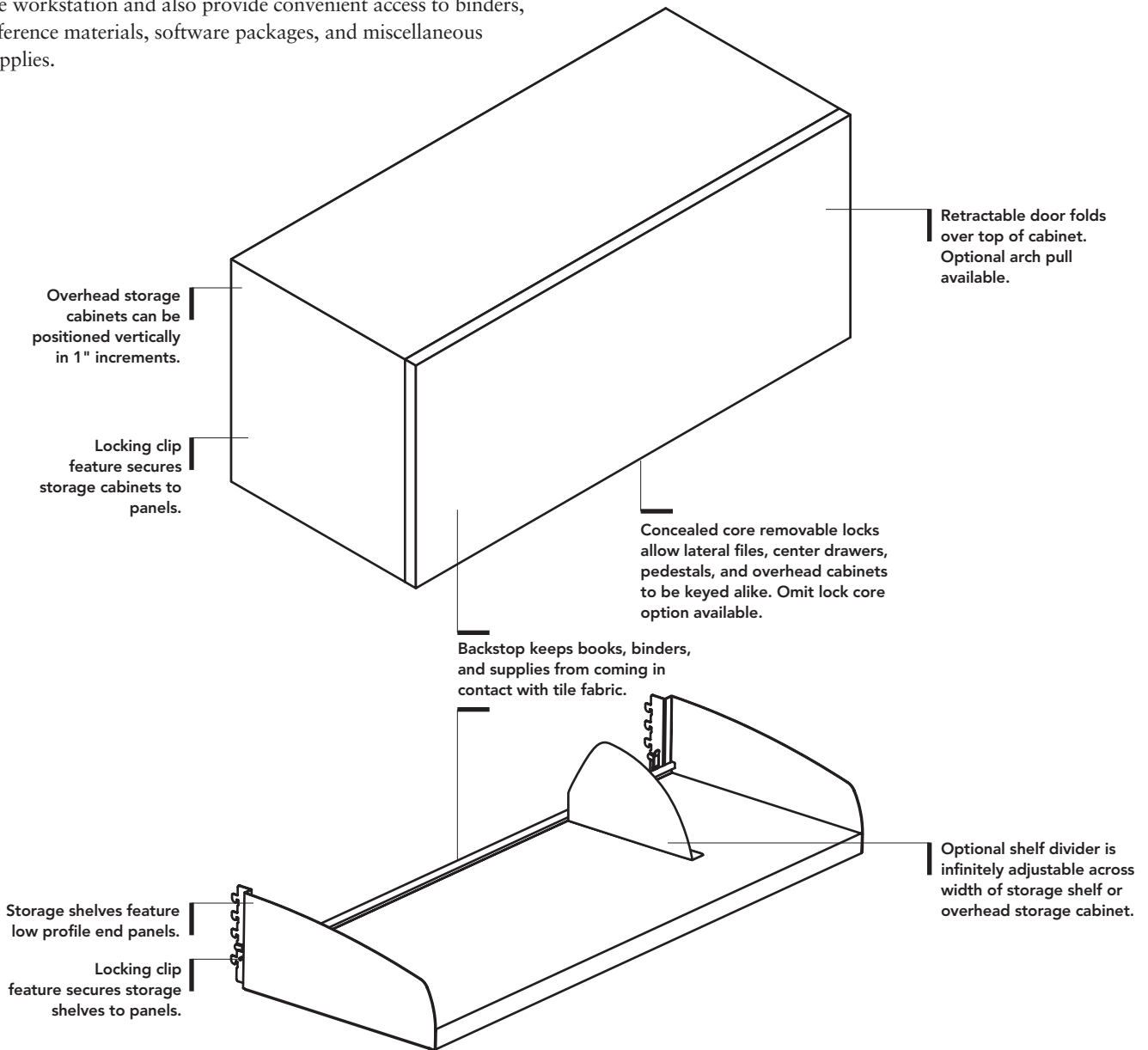

Product dimensions

Overhead Storage Cabinet

Width 24" (except receding door), 30", 36", 42", 48", 60" (with 2 doors)

Inside width ⅝" less than width

Depth 14¼" (Receding Door is 13¼"D)

Inside depth 12⅞" (Receding Door is 12⅞"D)

Height 15" (Receding Door is 15"H)

Inside height 12¾" (Receding Door is 11⅝"H)

Bookshelf

Width 24", 30", 36", 42", 48", 60"

Depth 14¼"

Height 6"

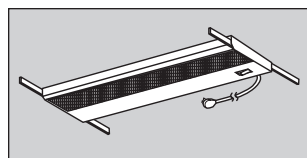

Task lights can be mounted beneath storage shelves and overhead storage cabinets. Additional panel hung and freestanding lighting options are available.

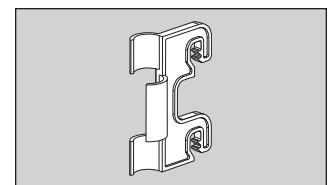

Cord retainer clips fasten into panel slots to anchor power cords. Available in black only. Clips are provided with under-shelf mounted task lights. Additional clips can be purchased separately. Painted or fabric covered cord covers are available for Concensys.

Specification Guidelines

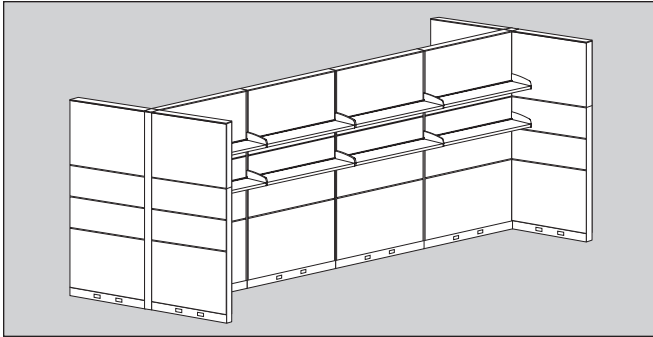

In a panel run, only two overhead storage cabinets or open storage shelves are recommended per panel side. Do not suspend more than one overhead storage unit per side from panels in a panel run which is mounted, at one or both ends, with an off-module connector kit.

When overhead storage units are suspended from stacking frames, the following guidelines should be adhered to:

Stacking frames should be added to all the parent run panels, and to each return-panel run. Stacking panels added to return panel must match the parent run configuration.

A maximum of two overhead storage units should be suspended from each side of stacking frames on any given panel.

With Concensys, a full height panel end cover is required for adequate stability when using overhead storage on the end of a run, or on a return panel.

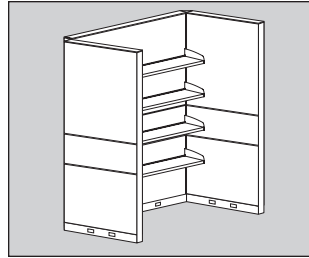

No limitation to the number of units on structural frames when run is supported with return panels on each side of storage shelves or overhead storage cabinets.

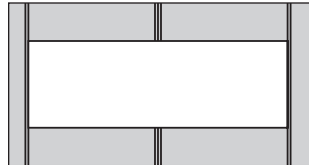

Storage shelf and receding door overhead width must correspond with width of panel(s). It is possible to span two panels when combined panel width equals cabinet or shelf width.

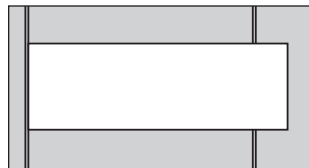

Overhead cabinets can be mounted on a panel equal to or up to 18" narrower than cabinet, or on panels wider than the overhead cabinet when using off-module kit. One side of overhead must be held on module.

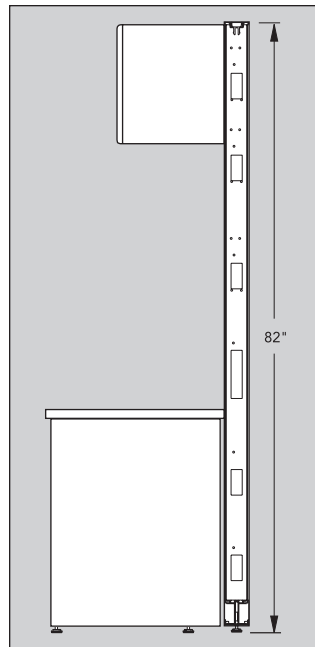
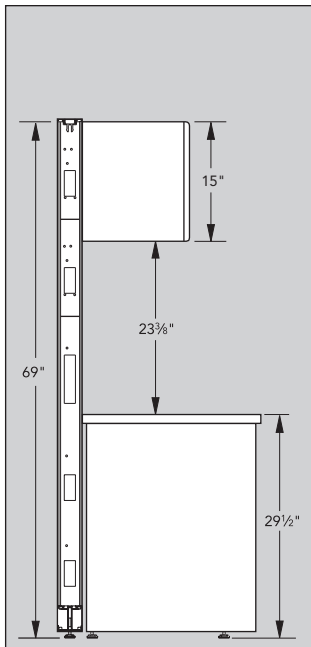

Overhead storage cabinets and open storage shelves can be mounted on Concensys structural and stacking panels to a maximum height of 69" (above left). They may be placed up to the top level of 82"H Concensys structural panels.

Overhead Cabinets, Upmount Kit, Bookshelves, and Tackboards

Overhead Cabinets with Flat Doors for Concensys

(page 228)

- Storage cabinets have flat flipper doors with square horizontal edges.
- Standard with a factory-installed core removable lock located on the underside of the cabinet.
- Width must correspond with width of panel or 2 panels joined with a straight connector.
- Cabinet has backstop.
- When mounted at an outside “T” connection or at an Extended Straight connection, there will be 2¼" between storage units.
- All units feature an anti-dislodgement device.
- 60" units are one-piece cabinet with two doors and locks.
- Accommodates recessed task lighting (specified separately).
- Storage cabinets are shipped pre-assembled.
- For locking specification, see pages 302-304.
- Cabinets are 14⅜"D x 15"H with inside dimensions of 12⅞"D x 14⅞"H.
- Concensys Essentials overhead cabinets can be mounted on a panel up to 18" narrower than the cabinet by using off-module overhead mounting kit COMBKT. Requires removal of existing vertical bracketry. (For units produced after 2/1/2004.)

Horizontal Wall Track (page 228)

- Allows for mounting Essentials™ overheads on permanent wall structures ONLY.
- NOT for mounting old style Essentials overheads or for receding door units.
- Track is 60"W and notched at 6" intervals as a guide for field cutting.
- Available in black only.
- Attachment hardware is not included.

Upmount Overhead Conversion Kit (page 228)

- Consists of two upmount brackets, full back panel and required installation hardware.
- Available in P1 and P2 colors.
- Allows mounting of overhead case up to 13" above height of panel.
- Brackets require a clearance of 6½" below bottom of overhead cabinet.
- Width must correspond with width of panel, or 2 panels joined without a connector.
- Full back panel adds ½" to depth of overhead case.
- Full back panel only used when upmounting cabinet.
- For use with overhead cabinets (except RTA and receding door units) produced after February 1, 2004.

Receding Door Overhead Storage Cabinet (page 228)

- Steel cabinet with open back. Optional back can be ordered separately.
- Arch or square pull optional.
- 60"W cabinet has 2 30"W doors with 2 independent locks.
- Accommodates recessed task lighting — ordered separately.
- For locking specifications, see pages 302-304.
- Cabinets are 13¼"D x 15"H. When door is recessed, interior dimensions are 12⅞"D x 11⅞"H.
- Weight Limits:
 - 30"W 70 lbs.
 - 36"W 85 lbs.
 - 42"W 100 lbs.
 - 48"W 110 lbs.
 - 60"W 138 lbs.

Receding Door Overhead Back (page 228)

- Optional for use with receding door overhead.
- Order width to match overhead cabinet.

Open Bookshelves (page 229)

- Width must correspond with width of panel or 2 panels joined with a straight connector.
- When mounted at an outside “T” connection or at an extended straight connection, there will be 2¼" between shelves.
- All units feature an anti-dislodgement device.
- Accommodates recessed task lighting (specified separately).
- Weight Limits:
 - 24"W61 lbs.
 - 30"W77 lbs.
 - 36"W93 lbs.
 - 42"W108 lbs.
 - 48"W124 lbs.
 - 60"W155 lbs.

Tackboards (page 229)

- Use 13"H with half-height shelves hung on 56"H panels.
- Use 18"H with 69"H and 82"H panels.
- Task light cords can be concealed behind tackboards.
- Can only be used on one panel in a 90° junction.
- Brackets come attached for mounting.

Hutches, Dividers, and Tackboards

Stack-on Hutches for Cadence (page 230)

- Stack-on hutches have flipper doors with square horizontal edges. Universal model can be converted to an open hutch.
- Stack-on hutches with doors are standard with a core removable lock (60"W, 66"W, and 72"W have two doors and two locks).
- Hutches mounted on a 29½"H x 1¼" thick worksurface corresponds with the height and look of Essentials overhead cabinets mounted on 69"H Concensys panels.
- Attachment tape provided.
- Order hutch to match width of worksurface(s) it covers.
- Stack-on hutches have a height clearance of 19¾" for computers, etc.
- Depth dimensions 14½" includes thickness of door, inside binder depth 12¾.
- Stack-on hutches are shipped easy-to-assemble.
- Accommodates recessed task lighting (specified separately).
- Chicago task light cords cannot be routed through the hutch end panels, due to the large size of the fused plugs.
- For locking specifications, see pages 302-304.

Dividers (page 230)

- Shelf dividers for use with stack-on hutches.

Tackboards (page 230)

- Use tackboard to close the back of stack-on or hutch below storage unit.
- Due to width of fabric roll, 72"W tackboards are available in railroad cut only.
- Tackboards for use with stack-on hutches.

Overheads

For specification information see pages 223-227.

GSA SIN 33721

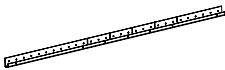
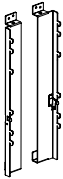
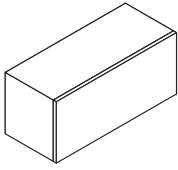

Description	Model	P1 Paint List Price	P2 Paint List Price	P3 Paint List Price
Overhead Cabinets w/Square Flipper Doors and Lock — 14 3/8" D x 15" H				
24" W	OH1524FD S	\$ 1041	\$ 1120	\$ 1197
30" W	OH1530FD S	\$ 1064	\$ 1143	\$ 1220
36" W	OH1536FD S	\$ 1116	\$ 1195	\$ 1272
42" W	OH1542FD S	\$ 1166	\$ 1245	\$ 1322
48" W	OH1548FD S	\$ 1219	\$ 1298	\$ 1375
60" W	OH1560FD S	\$ 1609	\$ 1688	\$ 1765

Note: Add Suffix **A** for arch pull or **S** for square pull option — add \$43 per pull.
For "Easy-Assist" on 24"W-48"W models change **FD** suffix to **FE** — add \$240.

Concensys Off-module Overhead Mounting Kit — for use with square flipper door cabinets				
COMBKT	S	\$ 141	\$ 160	\$ 174

Horizontal Wall Track (Black only)				
60" W Tracks	TWTH S	\$ 135		

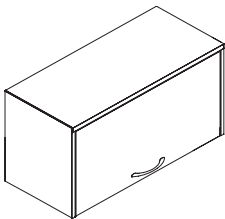

Description	Model	P1 Paint List Price	P2 Paint List Price	P3 Paint List Price
15" H x 13 1/4" D Receding Door Overheads (Inside dimensions with door recessed — 11 1/8" H x 12 1/8" D)				
30" W	OH1530RD	\$ 1221	\$ 1300	\$ 1377
36" W	OH1536RD	\$ 1288	\$ 1367	\$ 1444
42" W	OH1542RD	\$ 1368	\$ 1447	\$ 1524
48" W	OH1548RD	\$ 1483	\$ 1562	\$ 1639
60" W	OH1560RD	\$ 2243	\$ 2322	\$ 2399

Note: Add Suffix **A** for arch pull or **S** for square pull option — add \$43 per pull.

<p>How to specify — Select the Model Number from above.</p>	<p><i>1st Option:</i> Pull (if applicable): A Arch Pull, add \$43 per pull S Square Pull, add \$43 per pull</p>	<p><i>2nd Option:</i> System for Flipper Door Overhead: CM Concensys System for Receding Door Overhead (if applicable): YZ Concensys, Optimize™, Stride®, or Terrace® Z57 57 1/2" H Stride or Terrace</p>	<p><i>3rd Option:</i> Paint: P1 P2 P3 See page 180 for finishes.</p>	<p><i>4th Option:</i> Pull Color (if applicable): Arch: E4 Black EL Silver Square: EL Silver</p>	<p><i>5th Option:</i> Lock (if applicable): STD Standard OMT Omit Lock Core (Deduct \$20 per lock)</p>
<div style="display: flex; justify-content: space-between; width: 100%;"> </div>	<div style="display: flex; justify-content: space-between; width: 100%;"> </div>	<div style="display: flex; justify-content: space-between; width: 100%;"> </div>	<div style="display: flex; justify-content: space-between; width: 100%;"> </div>	<div style="display: flex; justify-content: space-between; width: 100%;"> </div>	<div style="display: flex; justify-content: space-between; width: 100%;"> </div>

Examples: OH1524FDN.CM.P7C.STD OH1560RD.YZ.P7C.STD S Shippable by small-package carrier.
OH1536RDA.YZ.P27.E4.OMT COMBKT.P27 TWTH Monolithic Panel Systems — 02/2024

For specification information see pages 223-227.



Description	Model	P1 Paint	P2 Paint	P3 Paint
		List Price	List Price	List Price
Shelf Dividers				
Package of 6	T7DV S	\$ 144	\$ 162	\$ 173

Note: Specify paint color. Shelf dividers can only be used on Persona™ radius and Essentials™ storage cabinets, open bookshelves, and hutches manufactured after 5/17/99. Not compatible with RTA models.



Description	Model	List Price		
		Grades A/B	Grades C/D	Grades E/F
Tackboards				
24"W x 13"H	861324 S	\$ 214	\$ 251	\$ 310
30"W x 13"H	861330 S	\$ 258	\$ 296	\$ 359
36"W x 13"H	861336 S	\$ 290	\$ 336	\$ 412
42"W x 13"H	861342 S	\$ 330	\$ 384	\$ 473
48"W x 13"H	861348 S	\$ 364	\$ 425	\$ 528
60"W x 13"H	861360 S	\$ 403	\$ 476	\$ 596
24"W x 18"H	861824 S	\$ 221	\$ 265	\$ 334
30"W x 18"H	861830 S	\$ 270	\$ 324	\$ 413
36"W x 18"H	861836 S	\$ 304	\$ 368	\$ 471
42"W x 18"H	861842 S	\$ 347	\$ 421	\$ 543
48"W x 18"H	861848 S	\$ 381	\$ 466	\$ 606
60"W x 18"H	861860 S	\$ 421	\$ 517	\$ 676



Description	Model	P1 Paint List Price	P2 Paint List Price	Fabric Covered List Price		
				Grades A/B	Grades C/D	Grades E/F
Cord Covers for Concensys						
13"H Fabric Covered	EL97 S	N/A	N/A	\$ 74	\$ 87	\$ 95
13"H Painted	EL96 S	\$ 54	\$ 67	N/A	N/A	N/A
18"H Fabric Covered	EL99 S	N/A	N/A	\$ 74	\$ 87	\$ 95
18"H Painted	EL98 S	\$ 54	\$ 67	N/A	N/A	N/A

Specify paint color or panel fabric.

<p>How to specify — Select the Model Number from above.</p>	<p><i>1st Option:</i> Paint (for Open Bookshelf): P1 P2 P3 See page 180 for finishes.</p>	<p><i>1st Option:</i> Fabric (for Tackboards): See page 10 for fabrics.</p>
--	--	--

Examples: 861324.LC928 EL97.APN911

S Shippable by small-package carrier.

Hutches

For specification information see page 227.

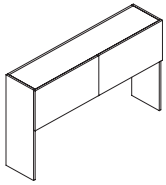

Description	Model	P1 Paint List Price	P2 Paint List Price	P3 Paint List Price
Universal Stack-on Hutch w/Square Flipper Doors and Lock — 14½"D x 35"H				
36"W	UH6536FD	\$ 1200	\$ 1282	\$ 1362
42"W	UH6542FD	\$ 1255	\$ 1337	\$ 1417
48"W	UH6548FD	\$ 1297	\$ 1379	\$ 1459
60"W	UH6560FD	\$ 1838	\$ 1920	\$ 2000
66"W	UH6566FD	\$ 1928	\$ 2010	\$ 2090
72"W	UH6572FD	\$ 2020	\$ 2102	\$ 2182



Shelf Dividers					
Package of 6	T7DV	<input type="checkbox"/>	\$ 144	\$ 162	\$ 173

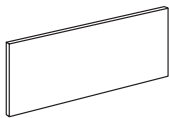

Description	Universal Hutch Model	P1 Paint List Price — Fabric			P2 Paint List Price — Fabric			P3 Paint List Price — Fabric			
		Grades A/B	Grades C/D	Grades E/F	Grades A/B	Grades C/D	Grades E/F	Grades A/B	Grades C/D	Grades E/F	
20"H Tackboards for Stack-on Hutches											
36"W Tackboard	UHTB36	<input type="checkbox"/>	\$ 540	\$ 637	\$ 798	\$ 567	\$ 664	\$ 825	\$ 590	\$ 687	\$ 848
42"W Tackboard	UHTB42	<input type="checkbox"/>	\$ 567	\$ 669	\$ 837	\$ 594	\$ 696	\$ 864	\$ 617	\$ 719	\$ 887
48"W Tackboard	UHTB48	<input type="checkbox"/>	\$ 618	\$ 734	\$ 924	\$ 645	\$ 761	\$ 951	\$ 668	\$ 784	\$ 974
60"W Tackboard	UHTB60	<input type="checkbox"/>	\$ 692	\$ 837	\$ 1077	\$ 719	\$ 864	\$ 1104	\$ 742	\$ 887	\$ 1127
66"W Tackboard	UHTB66	<input type="checkbox"/>	\$ 728	\$ 886	\$ 1149	\$ 755	\$ 913	\$ 1176	\$ 778	\$ 936	\$ 1199
72"W Tackboard	UHTB72	<input type="checkbox"/>	\$ 767	\$ 924	\$ 1184	\$ 794	\$ 951	\$ 1211	\$ 817	\$ 974	\$ 1234

How to specify — Select the Model Number from above.	1st Option: Pull <i>(if applicable):</i> Add \$43 per pull. A Arch Pull S Square Pull	2nd Option: Paint: <input type="checkbox"/> <input type="checkbox"/> <input type="checkbox"/> See page 180 for finishes.	3rd Option: Lock <i>(if applicable):</i> STD Standard — Random Keyed OMT Omit Lock Core (Deduct \$20 per lock)	3rd Option: Fabric (Tackboard only): See page 10 for fabrics.	4th Option: Railroad Cut (Tackboard only): (Only applicable to 66" and 72" W Fabric Tackboards.)
_____	_____ .	P _____ .	_____	_____ .	_____ R R

Examples: UH6536FDA.P7D.STD UH6536FD.P7D.OMT Shippable by small-package carrier.

UHTB36.P93.APN915 UHTB66.P93.APN915.RR

For complete specification and pricing information see the Storage Price List.

GSA Reference Page

Align Metal Pedestals — support or mobile



File/File
28½"H x 15"W
18", 23¼", 29¼"D



Box/Box/File
28½"H x 15"W
18", 23¼", 29¼"D



File/File
26½"H x 15"W
18", 23¼", 29¼"D



Box/Box/File
26½"H x 15"W
18", 23¼", 29¼"D



Box/File
20½"H Mobile,
22"H Freestanding
18", 23¼", 29¼"D x 15"W

Plinth base shown, models available with Stride or Terrace feet. Choice of metal or laminate fronts.

Align Low Metal Storage — credenzas, right and left configurations available

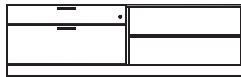

Box/Lateral/Open
72"W
22"H x 18", 24"D

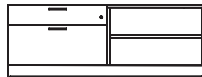

Box/Lateral/Open
60"W
22"H x 18", 24"D



Box/Lateral/Open
48"W
22"H x 18", 24"D



Box/Lateral/Open
42"W
22"H x 18", 24"D



Box/Lateral
24", 30", 36", 42"W
22"H x 18", 24"D

Plinth base shown, models available with Stride or Terrace feet. Choice of metal or laminate fronts.

Align Metal Lateral and Personal Files



2-High
28"H
30", 36", 42"W
18"D



2-High
28"H
30"W
18"D



2-High
28"H
24", 30", 36"W
18"D



Open
24", 30", 36", 42"W
22"H x 18", 24"D

Plinth base shown, models available with Stride or Terrace feet. Choice of metal or laminate fronts.

Align Metal Personal Towers — Stride®/Terrace®/Optimize™ Height — left configuration shown, also available right

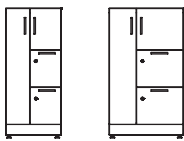

42½"H
18", 24"W
24"D

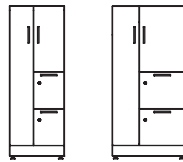

50"H
18", 24"W
24"D



57½"H
18", 24"W
24"D



65"H
18", 24"W
24"D

Plinth base shown, models available with Stride or Terrace feet. Choice of metal or laminate fronts.

Align Lockers — Overview — Left configurations shown, also available right

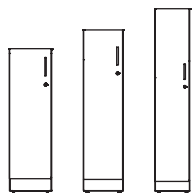

Single 12"W
42½", 50", 65"H / 18", 24"D

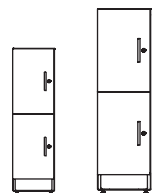

Double 12"W
42½", 65"H / 18"D

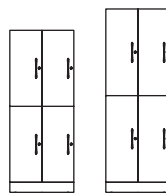

Quad 24"W
42½", 65"H / 18"D

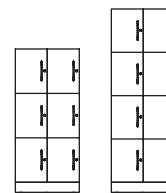

Cubby 24"W
50", 65"H / 18"D

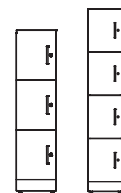

Cubby 12"W
50", 65"H / 18"D

Plinth base shown, models available with Stride or Terrace feet. Choice of metal or laminate fronts.

Approach Pre-configured Desks & Tables — height-adjustable 27¼"-47¾"H, fixed height 29½"H, left and right configurations

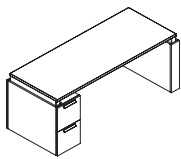

Height-Adjustable w/Storage
72", 66"W x 36", 30"D

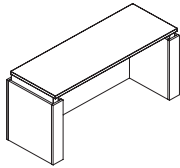

Height-Adjustable w/ and w/o Modesty
72"-48"W x 36", 30"D

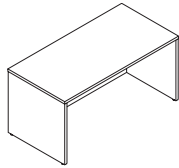

Shell Desk
60, 66, 72"W x 30"D

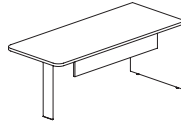

Racetrack Top w/Column, End Panel, and Modesty
72", 66"W x 30"D

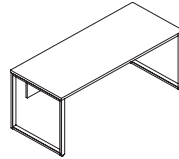
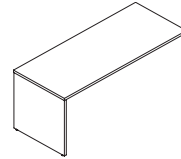
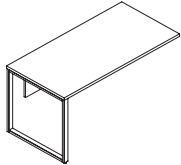

Table Desk with "O" Legs
72", 66"W x 30"D



With End Panel
84"-48"W x 30"D



With "O" leg
84"-48"W x 30"D

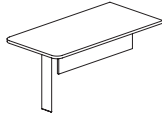

Racetrack Top w/Column
60", 54", 48"W x 30"D

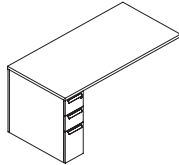

With Pedestal
72"-48"W x 30"D

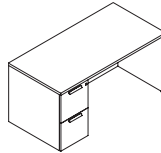

Single 15"W Ped Desk
60, 66, 72"W x 30"D

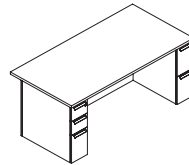

Double Ped Desk
72"W x 36"D

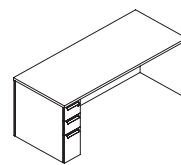

Single Slim Ped Desk
72", 66", 60"W x 36", 30"D

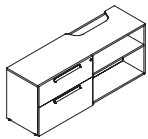

Credenza for Integrated HAT
60, 72"W
18, 24"D

APPROACH

Approach Credenzas — 28"H (shown) x 18"D or 24"D, 24"H x 18"D; most available to-the-floor base or feet with or without troughs.



Multi File
30"W

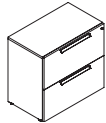

Lateral File
Only 28"H x 36", 30"W

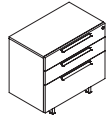

Box/Box/File 28"H
Box/File 24"H
36", 30"W

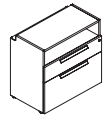

Open/Box/File
Only 28"H x 36", 30"W

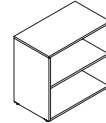

Open and Adjustable Shelf
36", 30"W

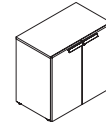

Hinged Doors and Adjustable Shelf
36", 30"W

Approach 28"H Double Credenzas — 18" or 24"D, left and right configurations, available to-the-floor base or feet with or without troughs.

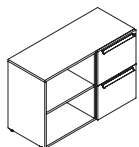

Open/Box/File
42"-48"W
18", 24"D

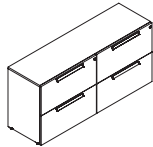

Lateral File/Lateral File
72", 60"W

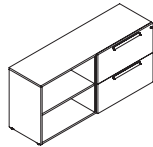

Lateral File/Open Shelf
72", 60"W

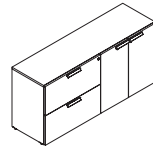

Lateral File/Hinged Doors
72", 60"W

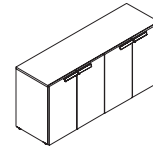

Four Hinged Doors
72", 60"W

Approach 24"H Double Credenzas — 24"H x 18"D; left and right configurations, most available to-the-floor base or feet with or without troughs.

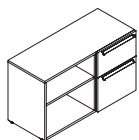

Open/Box/File
42"-48"W
18", 24"D

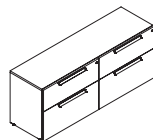

Box File/Box File
To-the-floor 72", 60"W

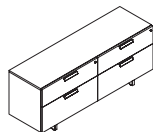

Box File/Box File
With Feet 72", 60"W

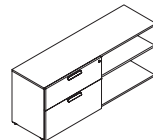

Box File/Open Shelf
72", 60"W

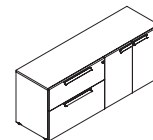

Box File/Hinged Doors
72", 60"W

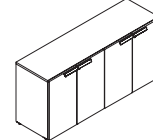

Hinged Doors/Hinged Doors
72", 60"W

Approach Pedestals — Mobile models have recessed casters



Mobile Box/File
21½"H x 16"W x 20"D

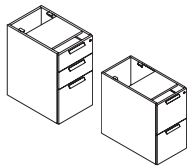

Support Pedestal
w/o Trough
28"H x 15"W
24, 30"D



Support Box/File
24"H x 18"W x 18"D

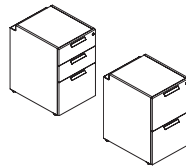

Support Box/Box/File and
File/File w/Troughs
28"H x 18"W x 18", 24"D

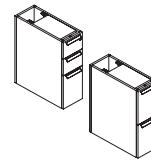

Support Slim Box/Box/File
and File/File w/Back Panel
28"H x 9½"W x 24", 30"D

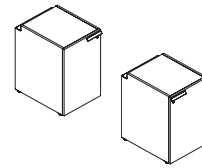

Support Left- and Right-Hand
Hinged Door w/Troughs
28"H x 18"W x 18", 24"D

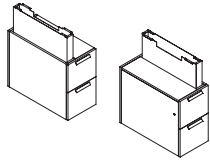

Height-Adjustable Slim
Ped & Shroud Kit
14½"W x 30"D

Approach False Peds, Wall Access Panels, Bridges, and Back Panels

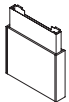

Height-Adjustable Shroud Kit
5½"W x 30"D
27"-47"H

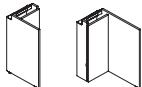

False Ped Left/Right
28"H x 12"W x
14, 18", 24"D



Wall Access Panel
28"H x 18", 24", 30", 36",
42", 48"W

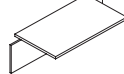

Bridge w/14"H Modesty
42", 48"W x 24"D



Back Panels 28", 24", 20"H
18", 30", 36", 60" 72"W

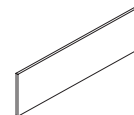

Modesty Panels
14"H x 30"-72"W

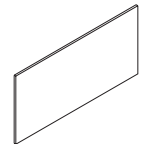

Full Height Modesty
42"-72"W

Approach Tops, Worksurfaces, and Supports — End Panels left- and right-handed



Cushion Tops for Mobile Ped
& Credenzas
16" x 20" / 30", 36" x 18"

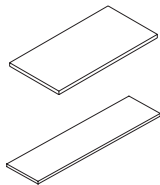

True and Shortened Depth
Laminate Tops
18"D, 24"D x 18"W-96"W

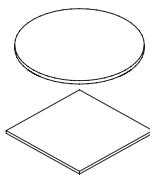

Round & Square Table Tops
36" / 42" / 48"

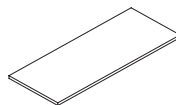

Laminate Worksurfaces
24"D, 30"D x 30"W-96"W
36"D x 72"W-84"W

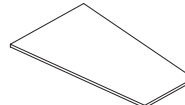

Double Sight line Wksfc.
36"-24"D x 60"-72"W
42"-30"D x 60"-72"W

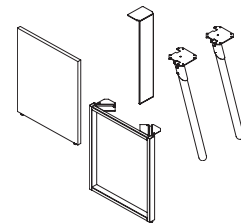

End Panels, O-Legs, Column &
Splay Leg Supports 28"H
14", 24", 30", 36"D

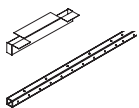

Stanchions & Support
Channel
3"H, 4"H x 12"D, 18"D
& 30"W-72"W



Metal O-Leg Chase

APPROACH

Approach Lateral Files, Bookcases, and Cubby — Laterals are 30" or 36"W x 18½"D, Bookcases are 30"W x 14¼"D, Cubby 7"H x 14"D

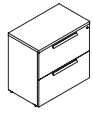

2-Drawer Lateral
29½"H



3-Drawer Lateral
42¼"H

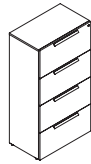

4-Drawer Lateral
56¼"H

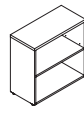

2-High Bookcase
29½"H

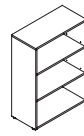

3-High Bookcase
42¼"H



4-High Bookcase
56¼"H

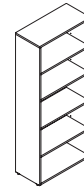

5-High Bookcase
71¼"H



Cubby Storage
18", 24", 30"W



8"D Floating Shelf
30"-78"

Approach Towers & Stack-On Storage — Towers 18"D, 24"D; Storage w/doors & Side Access 15"D, Open units 14½"D

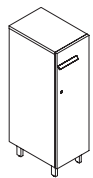

Wardrobe
42"-72"H
12", 18", 24"W
18", 24"D

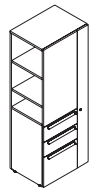

Side Access
42"-72"H
18", 24"W
18", 24"D

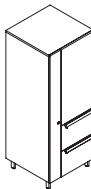

Combination
42"-72"H
18", 24"W
18", 24"D

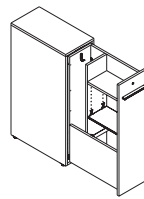

Pull Out Towers
42", 50"H
24", 30"D

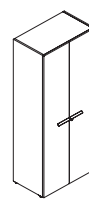

Tower w/Hinged Doors
30"W x 57½", 72"H

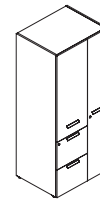

Combo Tower File/File
L- and R-Handed
30"W x 72"H



Open Access
L- and R-Handed
18"W x 57½", 72"H

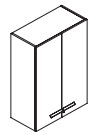

Stack-On w/Doors
18", 30", 36"W
x 29½, 42½"H

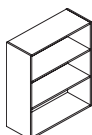

Stack-On Open
18", 30", 36"W
x 29½, 42½"H

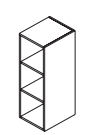

Stack-On Side Access
18"W
x 29½, 42½"H

Approach Overhead Storage — 15½"H x 15½"D with doors, open units 15½"D

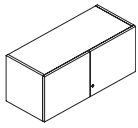

Hinged Doors
30"–78"W

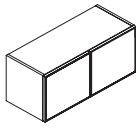

Writable Doors
30", 36", 60", 72"W

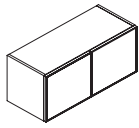

Frosted Glass Doors
30"–78"W

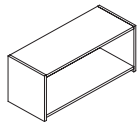

Open
30", 36"W

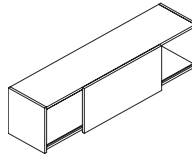

Sliding Door
48"–78"W



Overhead Mounting Kit
for Beyond Walls

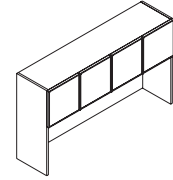

35"H Hutch
Lam. or Frosty Doors
48"–72"W

Approach Tackboards, Writable Boards, and Accessories — Tackboards and Writable Boards 30", 34", 45", 49"H

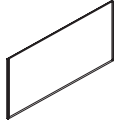

Tackboards for Hutches
48"W–72"W

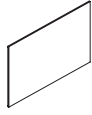

Tackboards
30"W–96"W

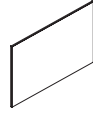

Writable Boards
30"W–96"W

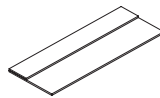

Counterweights
25, 35, 50, 60 lbs.

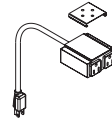

Mini Tap Power
6' Cord



End Cap

Altitude® Height-Adjustable Tops, Bases, and Accessories for Approach

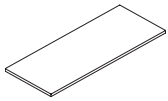

Altitude Tops
24", 30", 36"D x
48"-72"W

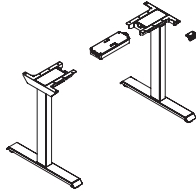

A6 T-leg Base 2-stage
22½"H-48½"H for
24"-30"D x 48"-84"W Tops

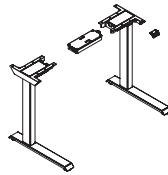

A6 C-leg Base 2-stage
27½"H-47½"H for
24"-30"D x 48"-72"W Tops

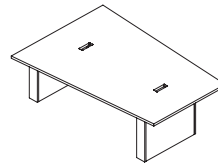

Collaborative
Height-Adjustable Tables
60"-48"D, 54-42"D, 42"-30"D

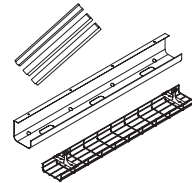

Wire Strips/Channels

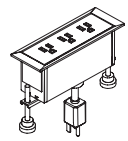

Power Modules
Power & USB

Extensions for Approach

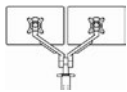

Monitor Arms
21"

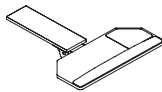

Articulating Keyboard
25"W x 10½"D



CPU Hammock
CPU 3-6"W x 16-23"H

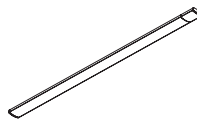

Under Cabinet LED Lights
17" & 31"

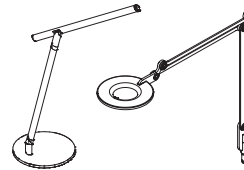

Link™ and Wand™ LED Lights
Base or Clamp

APPROACH

Leg or Plinth Base models available. Leg base units are shown below.

Pedestals — 24"H and 28"H



Mobile
Box/File



Freestanding
Box/File



Freestanding
Open



Support
Box/Box/File



Support
File/File



Support
Open

Credenzas — 17½"H, left- and right-handed models available for handed units.



Single Lateral

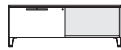

Single Lateral
w/Open Cubby



Corner Table

Credenzas — 24"H, left- and right-handed models available for handed units.



Box/Lateral



Box/Box
Lateral

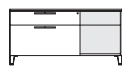

Box/Lateral
w/Open Cubby



Sliding Door
Open



Open

Credenzas — 28"H, left- and right-handed models available for handed units.



2-High
Lateral



Box/Box
Lateral



Box/Box
Project/Lateral



Sliding Door
Open w/Cubbies



Open

Credenzas and Bookcase — 42"H



3-High
Lateral

Bookcases — 65"H and 72½"H



Bookcase
w/Lateral



Bookcase

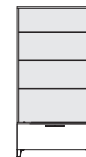

Bookcase
w/Lateral

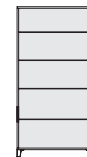

Bookcase

Towers — 42"H (12"W only), 50"H and 57½"H (50"H shown); left- and right-handed models available.

12"W



Full-Width Door

18"W



Hinged Door
Box/Box/File

18"W



Side Access
File/File

24"W



Hinged Door
Box/Box/File

24"W

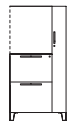

Side Access
File/File

Towers — 65"H and 72½"H (65"H shown); left- and right-handed models available.

12"W



Full-Width Door
(65"H)

18"W



Hinged Door
Box/Box/File

18"W



Hinged Door
File/File

18"W



Full-Width
Door

24"W



Hinged Door
Box/Box/File

24"W

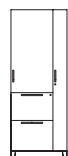

Hinged Door
File/File

24"W



Full-Width Door

Leg or Plinth Base models available. Leg base units are shown below.

Stacking Storage — Hinged Door, left- and right-handed models available

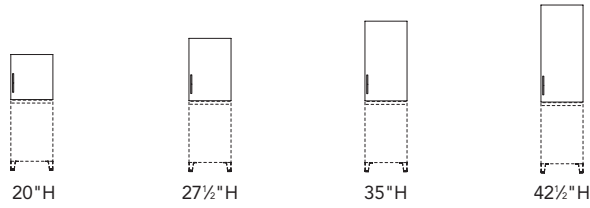

Stacking Storage — Open

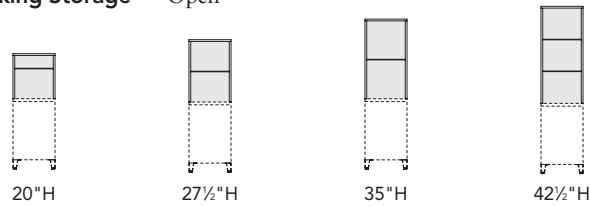

Overheads and Shelves

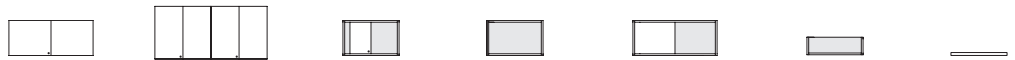

Hinged Door 15"H Hinged Door 22½"H Sliding Door Open Bin Dual Access Open Book Shelf Laminate Shelf

Soft Seating and Tables



Seat Base w/Drawers Seat Base w/Open Cubby Banquette Cushion Seat Base Cushion Table Top Bolster Corner Table Open Table

Worksurfaces — Shapes below added for Involve to the hundreds available in our existing Worksurface selection.

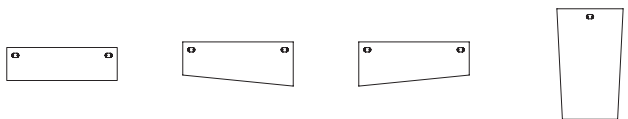

Primary 18"D Linear Taper 18"D / 24"D Linear Taper 24"D / 18"D EZ View Transition

Supports and Accessories



Open Metal End Supports Closed Laminate End Supports Post Leg Worksurface Stanchion Overhead Stanchion

Modesty Panels and Screens

Accessories



Modesty Panels Back Panels Privacy Panels Divider Panels Ped/Credenza Cushion Pullout Shelf Extra Metal Shelf Power Module

INVOLVE

- Software support packages furnished to the customer, either by Allsteel® or by another source, which support the sale of Allsteel products are superseded by printed price lists.
- Prices are subject to change without notice. All orders are subject to prices in effect at the time of order.
- Please refer to your Allsteel Dealer Sales and Discount Policies for order placement information, terms and conditions.
- Additional copies of this Specification and Price List are available upon request from Allsteel Literature at 1-866-255-7833.

- Ordering information appears at the bottom of each product page complete with examples on how to specify. Fabric and finish pages are referenced at the bottom of product pages.

This publication is available as an interactive or downloadable PDF at www.allsteeloffice.com.

Questions or Comments?

Please call us at: **888-ALLSTEEL**
888-255-7833

Paint Finishes, Laminates, Eased Edge	240
Fabrics.....	241
Working with Height-Adjustable Tables	242-247.2
Screens and Power Module	248
Altitude - Metal Screens.....	249-250
Power Rail Specifications	251-257
General Overview	251
Power Rail Typical.....	252
Working with Altitude Power Rails	253
Low Rail with Floor Legs	253
Raised Rail.....	253
Screens	253
Working with Cable Management	254
Working with Power Rail Electricals	255
General Notes about Electrical and Circuitry	255
Electrical Infeeds.....	255
Routing Power	256-257
Working with Electrical and Data	258-262
HAT to Panel Brackets	263-264
Working with Organization Rail & Accessories & Screens.....	265
Altitude Height-Adjustable Tops, Bases, & Accessories.....	266-283
Altitude – A6.....	266-267
Worksurfaces for Height-Adjustable Bases	268-270
Cable Management	271-271.3
Power Rail – Electrical Components.....	272-274
A8 Screen Kits.....	275
Metal Screens and Tackboard Accessories.....	276-277
Power Rails and Accessories	278-281
HAT to Panel Brackets Pricing.....	282
Worksurface Mounted Rail and Accessories	283

BASE COLORS

GRADE P1

Black.....	P71
Brownstone.....	P7D
Cinder.....	P7Q
Cove.....	P096
Designer White.....	PJW
Dune.....	P094
Flint.....	P02
Fossil.....	P28
Harbor.....	P097
Loft.....	P7B
Muslin.....	P4J
Nickel.....	P8L
Parchment.....	P93
Pebble.....	P8R
Pewter.....	P8D
Sage.....	P095
Salt.....	P8C
Titanium.....	P8T

GRADE P2

Champagne Metallic.....	PR5
Gunmetal Metallic.....	PR3
Night Bronze.....	P8B
Platinum Metallic.....	PR2
Silver.....	PR6

GRADE P3

Bullseye*.....	PJF
Regatta*.....	P8M

***Altitude Basic is only offered in one finish, Silver (SVR)

POWER RAIL PAINT COLORS

GRADE P1

Black.....	P71
Brownstone.....	P7D
Bungalow.....	P7C
Cinder.....	P7Q
Designer White.....	PJW
Flint.....	P02
Fossil.....	P28
Loft.....	P7B
Muslin.....	P4J
Pebble.....	P8R
Pewter.....	P8D
Salt.....	P8C
Titanium.....	P8T

GRADE P2

Champagne Metallic.....	PR5
Gunmetal Metallic.....	PR3
Night Bronze.....	P8B
Pyrite.....	PJE
Silver.....	PR6
Solar Black.....	P8X

GRADE P3

Atom.....	P8S
Blossom***.....	P8K
Ember.....	P8P
Ion.....	P8N
Iris.....	P8J
Krypton.....	P8F
Ochre.....	P093
Regatta.....	P8M
Sienna.....	P092
Succulent***.....	P8A

***These colors are intended to be an inspirational option for the trending market. Product application is limited and color availability is approximately two years to coincide with evolving workplace trends.

A8 SCREEN BRACKET PAINT COLORS

GRADE P1

Black.....	P71
Designer White.....	PJW

GRADE P2

Silver.....	PR6
-------------	-----

LAMINATES

GRADE L1

SOLID COLORS

Black.....	P
Brownstone.....	LM13
Bungalow.....	LM12
Designer White.....	LDW1
Flint.....	LM16
Fossil Shale.....	LEH1
Loft.....	LM11
Muslin.....	LM15
Titanium.....	LTI1

ABSTRACT

Ash.....	LT3B
Handspun Pearl.....	LAHP
Handspun Dove.....	LAHD
Handspun Slate.....	LAHS
Handspun Chestnut.....	LAHC
Silver Mesh.....	LT8D

WOODGRAIN

Belair.....	LWBA
Bourbon Cherry.....	H
Field Elm.....	LWFE
Florence Walnut.....	LFW1
Kingswood Walnut.....	LK11
Natural Maple.....	LWD
NeoWalnut.....	LNU1
Pinnacle.....	PINC
Shaker Cherry.....	LW7C

GRADE L2

Beigewood.....	LWBE
Fawn Cypress.....	LFC1
Lowell Ash.....	LLA1
Mangalore Mango.....	LMM1
Natural Recon.....	LNR1
Phantom Charcoal.....	LPC1
Phantom Ecru.....	LPE1
Portico Teak.....	LPT1
Skyline Walnut.....	LSW1
Veranda Teak.....	LVT1

GRADE L3

Natural Walnut.....	LWNW
---------------------	------

EASED EDGE LAMINATES

GRADE L1

Designer White.....	LDW1
Loft.....	LM11
Natural Maple.....	LWD

GRADE L2

Natural Recon.....	LNR1
--------------------	------

STRAIGHT/ROUNDED EDGE COLORS

Beigewood.....	DE
Belair.....	BA
Black.....	E4
Bourbon Cherry.....	H
Brownstone.....	EY
Bungalow.....	EX
Designer White.....	DW
Fawn Cypress.....	FC
Field Elm.....	FE
Flint.....	E9
Florence Walnut.....	FW
Fossil.....	EH
Kingswood Walnut.....	KI
Loft.....	EV
Lowell Ash.....	DL
Mangalore Mango.....	MM
Muslin.....	EU
Natural Maple.....	DD
Natural Recon.....	NR
Natural Walnut.....	DN
NeoWalnut.....	NU
Parchment.....	EN
Phantom Charcoal.....	PC
Phantom Ecru.....	PE
Pinnacle.....	PI
Platinum Metallic.....	EP
Plyband.....	PL
Portico Teak.....	DP
Shaker Cherry.....	DF
Skyline Walnut.....	SW
Titanium.....	TI
Veranda Teak.....	VT

ELECTRICAL & DATA COMPONENTS

Black.....	E4
Brownstone.....	EY
Designer White.....	DW
Flint.....	E9
Loft.....	EV
Muslin.....	EU
Silver.....	ES

METAL ACCESSORIES PAINT COLORS

GRADE P1

Black.....	P71
Brownstone.....	P7D
Bungalow.....	P7C
Charblack.....	CBK
Cinder.....	P7Q
Cove.....	P096
Designer White.....	PJW
Dune.....	P094
Flint.....	P02
Fossil.....	P28
Harbor.....	P097
Loft.....	P7B
Muslin.....	P4J
Parchment.....	P93
Pebble.....	P8R
Pewter.....	P8D
Platinum Metallic Texture.....	P6H
Sage.....	P095
Salt.....	P8C
Textured Brownstone.....	P7J
Textured Designer White.....	PK7
Textured Flint.....	P7A
Textured Loft.....	P7L
Textured Muslin.....	P7M
Textured Pebble.....	P8Y
Textured Salt.....	P8Z
Textured Titanium.....	P8V
Titanium.....	P8T
White.....	PD8

GRADE P2

Champagne Metallic.....	PR5
Graphite Metallic Texture.....	P85
Gunmetal Metallic.....	PR3
Matte Gold.....	P8G
Night Bronze.....	P8B
Platinum Metallic.....	PR2
Pyrite.....	PJE
Silver.....	PR6
Silver Generic.....	SVR
Silver Texture.....	PR8
Solar Black.....	P8X

GRADE P3

Atom.....	P8S
Blossom.....	P8K
Bullseye.....	PJF
Ember.....	P8P
Ion.....	P8N
Iris.....	P8J
Krypton.....	P8F
Regatta.....	P8M
Succulent.....	P8A
Ochre.....	P093
Sienna.....	P092

All of Allsteel's tables are level® - 2 certified to the ANSI/BIFMA e3 Furniture Sustainability Standard. See www.levelcertified.org for more information.

NOTE: Refer to individual product pages for upcharges.

Fabrics

For use with Screen Kits.

GRADE A

NOBLE	
Aegean	NBLE18
Amethyst.....	NBLE19
Aspen	NBLE14
Aster	NBLE20
Blossom.....	NBLE21
Bluebell	NBLE22
Bordeaux.....	NBLE01
Brick	NBLE02
Chambray	NBLE10
Chamomile.....	NBLE23
Clementine	NBLE04
Conifer.....	NBLE24
Cottage	NBLE25
Darkness	NBLE26
Dawn	NBLE13
Denim	NBLE09
Desert Sand.....	NBLE27
Dewfall	NBLE28
Dusted Sage.....	NBLE29
Flax.....	NBLE30
Grass.....	NBLE07
Gunmetal	NBLE15
Harmony.....	NBLE31
Harvest	NBLE12
Ice Caves	NBLE32
Icicle.....	NBLE33
Inky.....	NBLE34
Iris.....	NBLE35
Jade.....	NBLE06
Knight	NBLE17
Mesa	NBLE03
Monarch	NBLE36
Pacific	NBLE08
Pitch.....	NBLE37
Queen Bee	NBLE38
Rainforest	NBLE05
Regal.....	NBLE11
Sandcastle	NBLE39
Sedona	NBLE40
Stormy	NBLE16
Sunbeam	NBLE41
Voyager.....	NBLE42
Windy Day.....	NBLE43

GRADE D

BLAZER LITE	
<i>(100% Pure New Wool)</i>	
Haven	PCAMBLT40
Retreat	PCAMBLT39
Solace.....	PCAMBLT70

ALTITUDE

Altitude height-adjustable bases are available in five styles:

A6

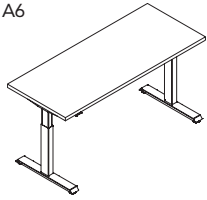

T-leg with
Rectangular Worksurface

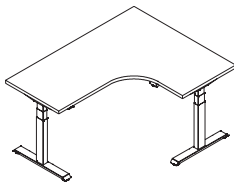

T-leg with
Corner Cove Worksurface

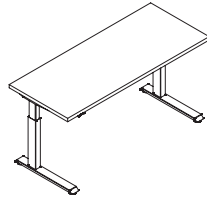

C-leg with
Rectangular Worksurface

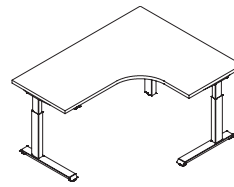

C-leg with
Corner Cove Worksurface

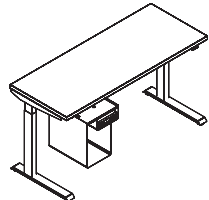

Altitude HAT
with Undermount
Radii Console

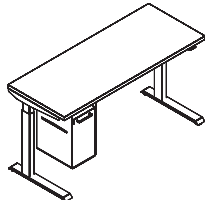

Altitude HAT
with Flush Undermount
Radii

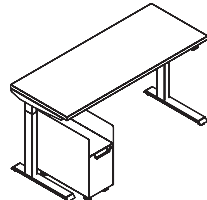

Altitude HAT
with Freestanding Mobile
Alcove Radii

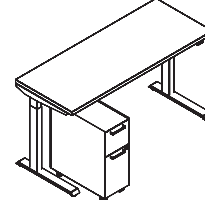

Altitude HAT
with Freestanding Mobile
Alcove Radii

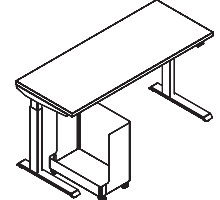

Altitude HAT with
Freestanding Mobile
Radii Caddy

A8 Screens

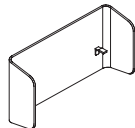

U Screen Kit

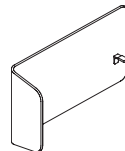

L Screen Kit (Left)

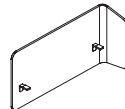

L Screen Kit (Right)

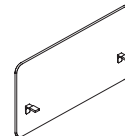

Rectangular Screen Kit

Metal Screens



L Screen (Left)



L Screen (Right)



U Screen

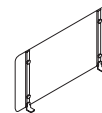

Straight

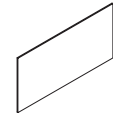

Tackboard Accessory

Altitude Power Rail

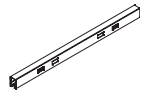

Altitude Power Rail

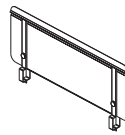

Altitude Rail Screen

A6 Clearance Dimensions

Rectangle

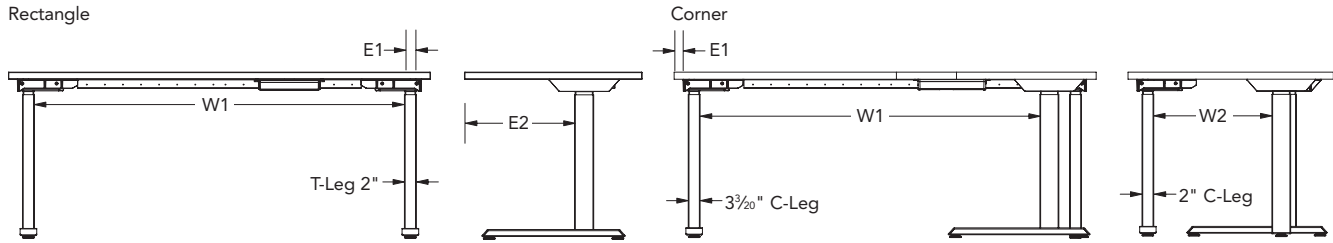

Base Style:	A6-T Base				A6-C Base				
	Dimension Location:	E1	W1	W2	E2	E1	W1	W2	E2
Altitude Top: (Surface dimensions are nominal. Actual widths are reduced by 2")	Edge of table to outside of leg	Between legs	Between legs	Edge of table to the outside of leg	Edge of table to outside of leg	Between legs	Between legs	Edge of table to the outside of leg	
24" x 48" Rectangle*	2½"	35¼"	—	10%"	2½"	35¼"	—	14¼"	
24" x 54" Rectangle	2½"	41¼"	—	10%"	2½"	41¼"	—	14¼"	
24" x 60" Rectangle	2½"	47¼"	—	10%"	2½"	47¼"	—	14¼"	
24" x 66" Rectangle	2½"	53¼"	—	10%"	2½"	53¼"	—	14¼"	
24" x 72" Rectangle	2½"	59¼"	—	10%"	2½"	59¼"	—	14¼"	
30" x 48" Rectangle	2½"	35¼"	—	13%"	2½"	35¼"	—	17%"	
30" x 54" Rectangle	2½"	41¼"	—	13%"	2½"	41¼"	—	17%"	
30" x 60" Rectangle	2½"	47¼"	—	13%"	2½"	47¼"	—	17%"	
30" x 66" Rectangle	2½"	53¼"	—	13%"	2½"	53¼"	—	17%"	
30" x 72" Rectangle	2½"	59¼"	—	13%"	2½"	59¼"	—	17%"	
60" x 36" Corner Cove	2½"	43"	26"	10%"	2½"	43"	29½"	14¼"	
60" x 48" Corner Cove	2½"	43"	32"	10%"	2½"	43"	35½"	14¼"	
72" x 36" Corner Cove	2½"	55"	26"	10%"	2½"	55"	29½"	14¼"	
72" x 48" Corner Cove	2½"	55"	32"	10%"	2½"	55"	35½"	14¼"	

Bottom Views

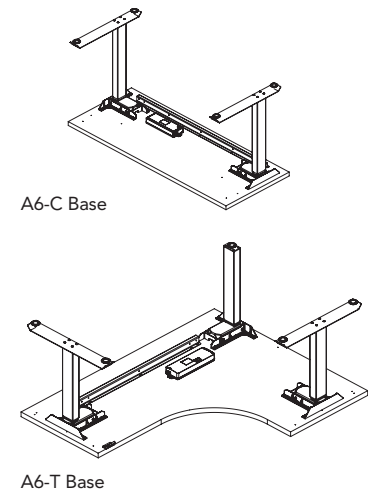

Feature	Altitude Basic	A6
Range Adjustment	26¼" – 43½"H + Adjustable Glide	2-Stage 26½" to 45¼" + ½" Adjustable Glide
Base Only, Without Work Surface		3-Stage 21¼" to 47½" + ½" Adjustable Glide
Range Adjustment	27¾" to 44"H + Adjustable Glide	2-Stage 27¾" to 46¾" + ½" Adjustable Glide
Includes Standard Allsteel 1½" Work Surface		3-Stage 22¾" to 48¾" + ½" Adjustable Glide
Foot Configuration	<ul style="list-style-type: none"> T Foot Standard leveling glide 	<ul style="list-style-type: none"> T Foot or C Foot Standard options include leveling glide, slide glides, and casters
Leg Options	2 leg	2 and 3 leg
UL Certified Weight Rating	180 lbs	<ul style="list-style-type: none"> 250 lbs for 2-leg 350 lbs for 2-leg Max 375 lbs for 3-leg 500 lbs for 3-leg Max
Cross Bar Design	Yes	A6 models ordered prior to 4/5/2021 have cross bar understructure, A6 models ordered after 4/5/2021 do not
Colors	Silver Only	20 Allsteel Paint Finishes offered, see Altitude Tables Finishes page
Control Pad	Up/down only	Basic up/down, memory preset, paddle, foot pedal
Wire Management	Allsteel standard options available Hinged trough not recommended	Allsteel standard options available
Power Access	Desktop power modules available	Desktop power modules available
Warranty	5 years	If Purchased Before 3/1/2021: 10 Years Metal Base, 7 Years Electronics If Purchased After 3/1/2021: 10 Years for Entire Product

Height-Adjustable Worksurfaces, Bases, and Controls

Height-Adjustable Worksurfaces (page 268)

- Height-adjustable worksurfaces are available in laminate with flat edge and rectangular veneer with matching square edge.
- T-mold is used on the edge of curved worksurfaces. This will have a noticeable visual difference when directly adjacent to straight worksurfaces.
- Worksurface dimensions are nominal. Actual widths are reduced by 2" (1" each side) and worksurface depths are reduced by ¼". Corner cove depth is nominal, actual is 1" less.
- Rectangular undersized worksurface models' (model number ending in -U) actual widths and depths are reduced by 2".
- Corner Cove undersized worksurface models' (model number ending in -LD) actual dimensions are reduced by 2".
- Altitude worksurfaces are pre-drilled with mounting location for bases.
- Rectangular worksurface grommet location is limited to center location due to mounting of worksurface supports at each end of the worksurface.
- Certain two-piece top configurations may require two stiffeners depending on the footprint of your station.
- 2-leg standard bases can accommodate worksurface configurations from 24"D x 24"W to 30"D x 72"W.
- 2-leg Max bases can accommodate worksurface configurations from 24"D x 24"W to 30"D x 96"W.
- 3-Leg standard bases can accommodate worksurface configurations from 24"D x 48"W x 36"W to 30"D x 72"W x 48"W.
- 3-Leg Max bases can accommodate worksurface configurations from 24"D x 48"W x 36"W to 30"D x 72"W x 72"W.
- Altitude A6 bases specified with a work surface 60"W and greater require the use of an external stiffener. An external stiffener is included in Altitude work surface models 60"W and greater (all models ending with letter -D). If a non-Altitude work surface is being used, an external stiffener may need to be specified separately.

Height-Adjustable Bases (pages 266-267)

- Electronic height-adjustable base units are available in six styles: A6-T Base with 2 legs, A6-C Base with 2 legs, A6-T Base with 3 legs, A6-C Base with 3 legs, A6-T Max Base with 2 legs, A6-C Max Base with 2 legs, A6-T Max Base with 3 legs, and A6-C Max Base with 3 legs.
- **A6 2-stage and 3-stage have a travel speed of 1.25"/second. A-6 Max bases have a travel speed of 1.96"/second.** Motor devices have a continuous cycle time of 2 minutes with an 18 minute rest period before it can be cycled again.
- Control box is powered by 110-120V/60Hz/4A. Standby power is < 0.1 Watts. Power cords on A6-T models are 10'.
- Pedestals taller than 24½" for 2-stage models and 19½" for 3-stage models when placed under table will limit range in lowest position.
- Mobile box/file pedestals will clear feet on height adjustable base but will extend past edge of worksurface in that position. See chart on page 243.
- Moving worksurfaces can collide with other components. It is important to ensure free range of motion prior to operating the table.
- All tables have adjustable glides providing ½" adjustment on A6.
- Slide glides offered as a .option and model level. Only available on 2-leg bases.
- Casters available on model level for retrofitting on 2-Leg Bases ONLY.
- Altitude A6 tables feature collision detection, a feature designed to stop table travel when the table detects an obstacle.
- A6 load capacity is 250 lbs for 2-leg models, 375 lbs for 3-leg models, 350 lbs for 2-leg Max models, and 500 lbs for 3-leg Max models. This includes the weight of the worksurface.
- G1 Glide enables the A63-stage height adjustable bases to reach the BIFMA G1 height requirements. Glides come in a pack of 4. Glide is always black.

A6 Control Options

- Memory Controls are now a .option.
- Up/Down: Basic Up/Down control.
- Memory Control: 4 memory pre-set options allow the user to adjust their height to their preferred heights.
- Paddle: Simple, aesthetic control with 1 memory pre-set option and reminder mode.
- Bluetooth Capability: A6 optional Bluetooth capability is sold as accessory model A6BLUETOOTH. Bluetooth is enabled through smartphone app AiDesk. Bluetooth control will only work with 2-leg A6 tables. Bluetooth control will **not** work with 3-leg A6 tables. No additional controls are required for use, but they can be used in addition to the bluetooth control (bluetooth plug in uses different port than other controls).

Note: HAT-to-Panel bracket does not work with the Max Base.

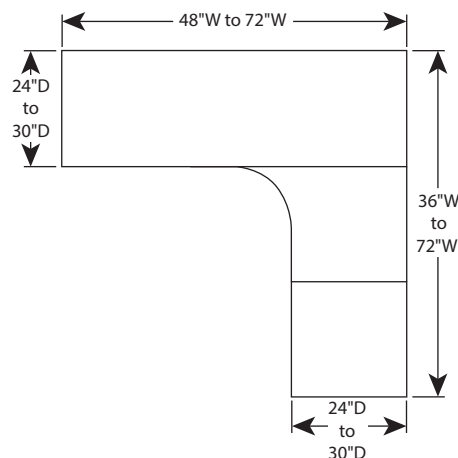
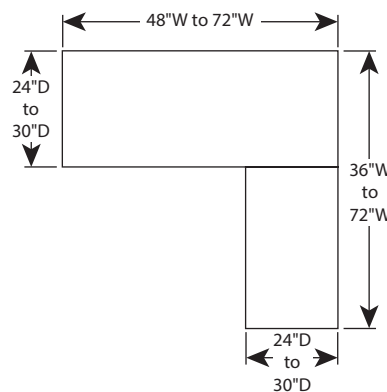
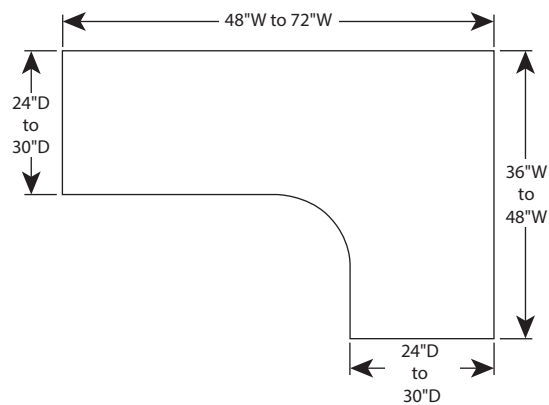

For specification information see page 244.

Rectangular Laminate Tops – 24"D

Base Model(s)	Actual Dimensions
AF5RS4824, AVF5RS4824	46"W x 23¼"D
AF5RS5424, AVF5RS5424	52"W x 23¼"D
AF5RS6024D, AVF5RS6024D	58"W x 23¼"D
AF5RS6624D, AVF5RS6624D	64"W x 23¼"D
AF5RS7224D, AVF5RS7224D	70"W x 23¼"D
AF5RS7824D	76"W x 23¼"D
AF5RS8424D	82"W x 23¼"D
AF5RS9024D	88"W x 23¼"D
AF5RS9624D	94"W x 23¼"D

Rounded Corner Laminate Tops – 24"D

Base Model(s)	Actual Dimensions
AF5RND4824	46"W x 23¼"D
AF5RND5424	52"W x 23¼"D
AF5RND6024D	58"W x 23¼"D
AF5RND6624D	64"W x 23¼"D
AF5RND7224D	70"W x 23¼"D
AF5RND7824D	76"W x 23¼"D
AF5RND8424D	82"W x 23¼"D
AF5RND9024D	88"W x 23¼"D
AF5RND9624D	94"W x 23¼"D

Rectangular Laminate Tops – 30"D

Base Model(s)	Actual Dimensions
AF5RS4830, AVF5RS4830	46"W x 29¼"D
AF5RS5430, AVF5RS5430	52"W x 29¼"D
AF5RS6030D, AVF5RS6030D	58"W x 29¼"D
AF5RS6630D, AVF5RS6630D	64"W x 29¼"D
AF5RS7230D, AVF5RS7230D	70"W x 29¼"D
AF5RS7830D	76"W x 29¼"D
AF5RS8430D	82"W x 29¼"D
AF5RS9030D	88"W x 29¼"D
AF5RS9630D	94"W x 29¼"D

Rounded Corner Laminate Tops – 30"D

Base Model(s)	Actual Dimensions
AF5RND4830	46"W x 29¼"D
AF5RND5430	52"W x 29¼"D
AF5RND6030D	58"W x 29¼"D
AF5RND6630D	64"W x 29¼"D
AF5RND7230D	70"W x 29¼"D
AF5RND7830D	76"W x 29¼"D
AF5RND8430D	82"W x 29¼"D
AF5RND9030D	88"W x 29¼"D
AF5RND9630D	94"W x 29¼"D

Undersized Rectangular Worksurface – 24"D

Base Model(s)	Actual Dimensions
AF5RS3624U	34"W x 22"D
AF5RS4224U	40"W x 22"D
AF5RS4824U	46"W x 22"D
AF5RS5424U	52"W x 22"D
AF5RS6024UD	58"W x 22"D
AF5RS6624UD	64"W x 22"D
AF5RS7224UD	70"W x 22"D
AF5RS7824UD	76"W x 22"D
AF5RS8424UD	82"W x 22"D
AF5RS9024UD	88"W x 22"D
AF5RS9624UD	94"W x 22"D

Undersized Rectangular Worksurface – 30"D

Base Model(s)	Actual Dimensions
AF5RS3630U	34"W x 28"D
AF5RS4230U	40"W x 28"D
AF5RS4830U	46"W x 28"D
AF5RS5430U	52"W x 28"D
AF5RS6030UD	58"W x 28"D
AF5RS6630UD	64"W x 28"D
AF5RS7230UD	70"W x 28"D
AF5RS7830UD	76"W x 28"D
AF5RS8430UD	82"W x 28"D
AF5RS9030UD	88"W x 28"D
AF5RS9630UD	94"W x 28"D

120 Degree Corner Worksurface – 24"D

Base Model(s)	Actual Dimensions
AF5120S4224D	22"A x 40"B x 40"C x 22"D
AF5120S4824D	22"A x 46"B x 46"C x 22"D
AF5120S5424D	22"A x 52"B x 52"C x 22"D

120 Degree Corner Worksurface – 30"D

Base Model(s)	Actual Dimensions
AF5120S4224D	28"A x 40"B x 40"C x 28"D
AF5120S4824D	28"A x 46"B x 46"C x 28"D
AF5120S5424D	28"A x 52"B x 52"C x 28"D

For specification information see page 244.

Corner Cove Laminate Tops – 24"D Extended Left

Base Model(s)	Actual Dimensions
A5822ELS	23¼"A x 58¼"B x 34½"C x 23¼"D
A5622ELS	23¼"A x 58¼"B x 46¼"C x 23¼"D
A5922ELS	23¼"A x 70¼"B x 34½"C x 23¼"D
A7222ELS	23¼"A x 70¼"B x 46¼"C x 23¼"D

Undersized Corner Cove Worksurface, Left Hand – 24"D

Base Model(s)	Actual Dimensions
AF5CCS603624LD	22"A x 58"B x 34"C x 22"D
AF5CCS604824LD	22"A x 58"B x 46"C x 22"D
AF5CCS723624LD	22"A x 70"B x 34"C x 22"D
AF6CCS724824LD	22"A x 70"B x 46"C x 22"D

Undersized Corner Cove Worksurface, Left Hand – 30"D

Base Model(s)	Actual Dimensions
AF5CCS604830LD	28"A x 58"B x 46"C x 28"D
AF5CCS724830LD	28"A x 70"B x 46"C x 28"D

Corner Cove Laminate Tops – 24"D Extended Right

Base Model(s)	Actual Dimensions
A5822ERS	23¼"A x 58¼"B x 34½"C x 23¼"D
A5622ERS	23¼"A x 58¼"B x 46¼"C x 23¼"D
A5922ERS	23¼"A x 70¼"B x 34½"C x 23¼"D
A7222ERS	23¼"A x 70¼"B x 46¼"C x 23¼"D

Undersized Corner Cove Worksurface, Right Hand – 24"D

Base Model(s)	Actual Dimensions
AF5CCS603624RD	22"A x 58"B x 34"C x 22"D
AF5CCS604824RD	22"A x 58"B x 46"C x 22"D
AF5CCS723624RD	22"A x 70"B x 34"C x 22"D
AF6CCS724824RD	22"A x 70"B x 46"C x 22"D

Undersized Corner Cove Worksurface, Right Hand – 30"D

Base Model(s)	Actual Dimensions
AF5CCS604830RD	28"A x 58"B x 46"C x 28"D
AF5CCS724830RD	28"A x 70"B x 46"C x 28"D

Cable & Wire Management

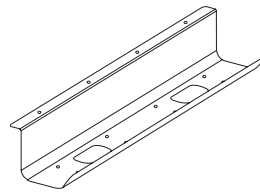

AJTRGH24 or AJTRGH36

Cable Management Tray (page 271)

- Attaches under the worksurface to contain cables.
- Metal tray shelf is 4" deep. Can hold electrical power strip and/or surge protector.
- 24" and 36" lengths, use multiple units for larger worksurfaces.
- Attachment hardware included, paint option is black only.
- Zip tie attachment points located in base of tray. Zip ties not included.

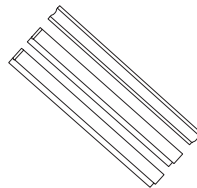

AWRSTRIP

Wire Management Strips/Channels (page 271)

- Self adhesive backing to attach to panels and underside of worksurfaces.
- Flexible strips allow cabling to enter/exit and can be contained inside the strips' cavities.
- Includes two wire management profiles. Smaller profile allows for qty. 3, .3" diameter cords, has area of .32 in². Larger "J" shaped profile allows for qty. 10, .3" diameter cords, has area of 1.14 in².

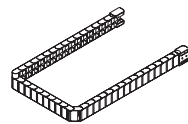

A9CLWMC or WKSWMC

Cord Management Chains (page 271)

- Works with Approach and Altitude A6-units.
- Used to route and conceal power/data cables from control box and other devices. Includes all mounting hardware and a plate to secure to a leveling glide.
- Houses 6 cables at 0.300" diameter.
- Made of plastic chain with plastic attachment brackets at each end.
- Specify WKSWMC for 58" chain. Only comes in Black finish.
- Specify A9CLWMC for 36" chain. Comes in Black, White, and Silver.
- Has two connecting points: Top section connects underneath a worksurface and bottom section can connect underneath power rails or to panel raceways using double-sided tape. Hardware included.

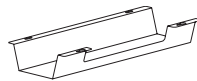

APWRTRGH17 or APWRTRGH36

Under Worksurface Trough (page 271)

- Used to conceal wires and control box below worksurfaces. Trough can be configured at various height/width combinations to meet capacity needs. Ships flat and is bent to desired shape.
- On 48"W and 54"W worksurfaces use one 17"W trough. 54"W has space to use 2 – 17"W, if necessary.
- On 60"W, 66"W, and 72"W worksurfaces use the 36" trough.
- On 84"W worksurface use 2 – 17"W troughs.

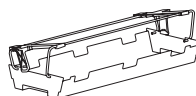

AFDTRGH20

Flip-Down Wire Trough (page 271)

- Mounts beneath a worksurface. Used to conceal extra cord slack and power strips.
- May be used in conjunction with quad tap unit APWR4TAP to reduce the number of cords routed from a worksurface to a beam.
- For any worksurface less than 58"W, a 20"W Flip-Down Trough is recommended.
- For worksurfaces 58"W and wider, a 20"W or 32"W Flip-Down Trough may be used.
- Flush-mount Raddi Storages are not recommended to use in conjunction with Flip-Down Trough.
- Only AKTSHORT keyboard tray is recommended for use in conjunction with the Flip-Down Trough.



AFDTRGH32

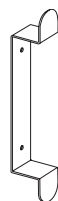

AWIRECLT

Metal Wire Cleat (page 271)

- Supplied with screws and VHB tape for attachment to various surface types.
- For wood/particle board/MDF surfaces, use screw attachment.
- For painted metal/glass/non-porous surfaces, use VHB tape.
- Example use cases:
 - 1) Used alongside telescoping/fabric HAT wire chases to secure excess length of cord at plug-end.
 - 2) Secured to wall next to TV monitor in meeting room to manage HDMI cable when not in use.
 - 3) Screwed underneath worksurface to provide quick and easy management of excess length of cords and cabling.

Cable & Wire Management

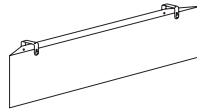

APWRMODEST36 or APWRMODEST48

Fabric Power Modesty (page 271.2)

- Fabric Power Modesty presents as modesty panel hanging by leather straps under a worksurface; inner compartment conceals cords and power strips as a wire management application.
- Recommended worksurface width pairings:
 - 1) 48-60" W Desk — Use APWRMODEST36 Centered.
 - 2) 66-72" W Desk — Use APWRMODEST48 Centered or APWRMODEST36 offset.
 - 3) 84" W Desk — Use APWRMODEST48 offset.
- Modesty fills 11.5 inches below the bottom of the worksurface with space for cords to enter/exit between the worksurface and the top of the Power Modesty.
- Two entry/exit points for cords are located at the bottom of the Power Modesty unit.
- Modesty panel is designed to present as a thin modesty panel from the front, but provides 3" depth cavity for wires, power strips, etc.
- Maximum weight capacity for Power Modesty is 25 lbs.
- Modesty panel not to be used to store electronics that require airflow for thermal management (computers).
- Users can access interior of panel (to modify wire placement) via "wings" on either side of product, secured via user-operable Velcro connection.
- Users may also dismount Power Modesty from leather straps by unlooping leather straps from button attachments.
- Leather straps on Power Modesty always come in medium brown color.
- Power Modesty available in Appoint, Binary, Centurion, Noble, Reflections, Disperse, and Spin fabric series.

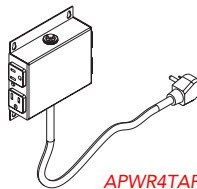

APWR4TAP

Power Module — Under Worksurface, Quad Tap (page 271.1)

- Under surface mounting, used on any worksurface with a 5" x 5" x 1.5" clearance.
- 10' Power cord. UL Listed.
- May be used in conjunction with Flip-Down Trough to reduce the number of cords routed from a worksurface to a beam.
- 4 receptacles, unit is black finish only, no specification needed.

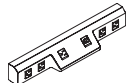

FDPWRC, CFDPWRC, FDPWRSC, or CFDPWRSC

Concealed Power Module (page 271.1)

- Contains 5 simplex outlets, 1 USB-A, and 1 USB-C.
- Available in plastic or metal. Metal power module is required for Chicago code.
- Cord options include straight and curly.
 - Straight cord is 144"
 - Curly cord is 120"
- If desired application is to set power module inside an under worksurface trough, MUST be specified with SPLA-ALT-BEAMA (contact Allsteel TPG for more information).
- Cannot be attached directly to the bottom of the worksurface.

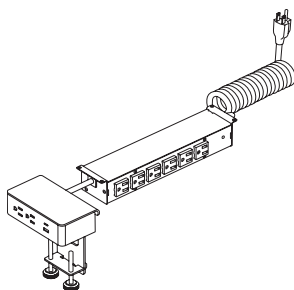

AABPWRMOD.AC.Q

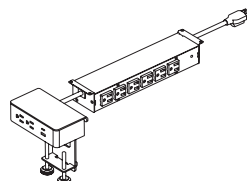

AABPWRMOD.AC.S

Power Module — Above/Below Worksurface (page 271.2)

- Above/Below power module provides access to power on the desktop and below the worksurface.
- Desktop mount can be used on any surface with a 6" W x 3" D clearance along the worksurface edge.
- Under surface mounting can be used with a 12" W x 3" D x 2" H clearance under the surface.
- Plugs will take additional depth (approx. 3").
- Two wire management "P-Clips" included with mounting hardware.
- Below worksurface power strip supplies six grounded A/C receptacles, desktop unit supplies two receptacles, 1 USB-A port, and 1 USB-C port.
- Desktop and under worksurface units are connected by a 2' long straight cord and cannot be disconnected.
- Power cord choices include a 6' straight cord or a coiled cord that is 6' long uncoiled, approximately 8" long coiled (compressed).
- Desktop unit available in White and Gray finishes.
- Under worksurface unit available in black only, no specification needed.
- UL 962A and UL 111 Listed. UL 1310 Recognized.

Cable & Wire Management

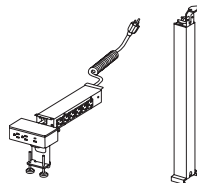

AHATPWORMOD2S or AHATPWORMOD3S

Metal Telescoping HAT Wire Management (page 271.3)

- Separate models available for use on either 2-Stage or 3-Stage Altitude A6 Tables. Not compatible with Altitude A3, A5, or A8.
- Equipped with 2-Stage or 3-Stage Telescoping Wire Chase and custom Above/Below Power Module intended for cord management on 2- and 3-Stage height adjustable tables.
- Telescoping chase includes a unique Above/Below Power Module and is NOT compatible with any other power module.
- Above/Below Power Module supplies 6 grounded A/C receptacles below the worksurface and 2 receptacles, 1 USB-A, and 1 USB-C port above the worksurface on the desktop unit. Desktop power module available in White and Gray finishes, below-worksurface power strip only available in black only.
- Telescoping Chase available in the same paint finishes as the Altitude height adjustable bases except for “Nickel.”
- To match Metal Telescoping Chase to HAT base, specify matching paint color as HAT base. To match Telescoping Chase to a “Nickel” HAT base, specify “Platinum Metallic,” or “PR2.”
- Two “P-Clips” included for wire management between desktop power module and under worksurface power strip.

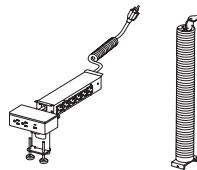

AHATPWORMOD2S or AHATPWORMOD3S

Fabric Elastic HAT Wire Management (page 271.3)

- Model compatible for use on either 2-Stage or 3-Stage Altitude A6 Tables. Not compatible with Altitude A3, A5, or A8.
- Equipped with Fabric Elastic Wire Chase and custom Above/Below Power Module intended for cord management on 2- and 3-Stage height adjustable tables.
- Fabric Elastic Chase includes a unique Above/Below Power Module and is NOT compatible with any other power module.
- Above/Below Power Module supplies 6 grounded A/C receptacles below the worksurface and 2 receptacles, 1 USB-A, and 1 USB-C port above the worksurface on the desktop unit.
- Desktop power module available in White and Gray finishes, below-worksurface power strip only available in black only.
- Fabric Elastic Chase available in Light, Medium, and Dark fabric finishes.
- Includes a metal foot and an under worksurface mounting bracket to attach Fabric Elastic Chase along the side of a HAT leg.
- To match metal brackets to HAT base, specify matching paint color as HAT base. To match brackets to a “Nickel” HAT base, specify “Platinum Metallic,” or “PR2.”
- Two “P-Clips” included for wire management between desktop power module and under worksurface power strip.

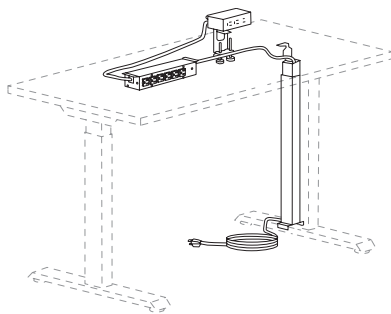

2-Stage Metal Telescoping HAT Wire Management

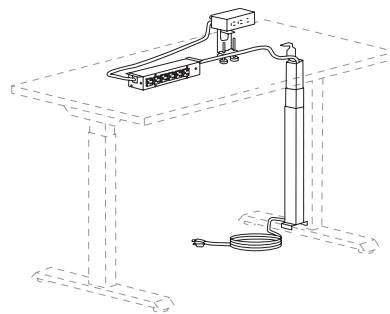

3-Stage Metal Telescoping HAT Wire Management

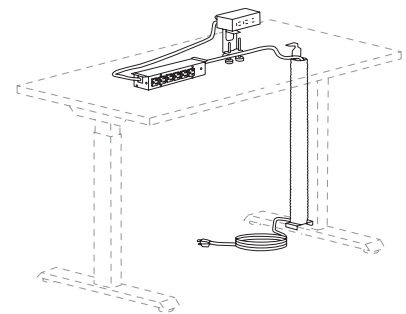

2 or 3-stage Fabric Elastic HAT Wire Management

For more power and wire management options, please visit the Extensions pages.

Screens

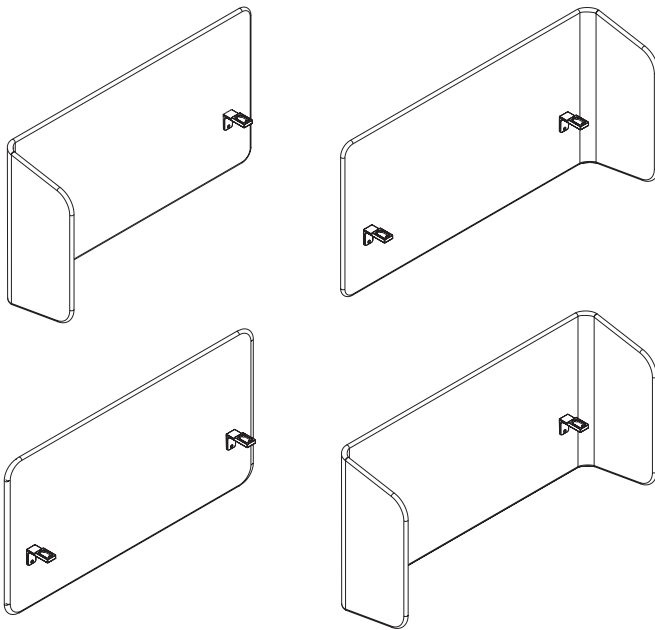

- See Table 1 for overall table width and depth for each screen shape.
- Adding a screen adds 3" to depth of the table.
- Adding a screen adds 1" to the width of the table per return wing.
- RH L-screens have return wing on user's right; LH opposite.
- When using a 24"D worksurface with Altitude screens, you must specify a T-foot.

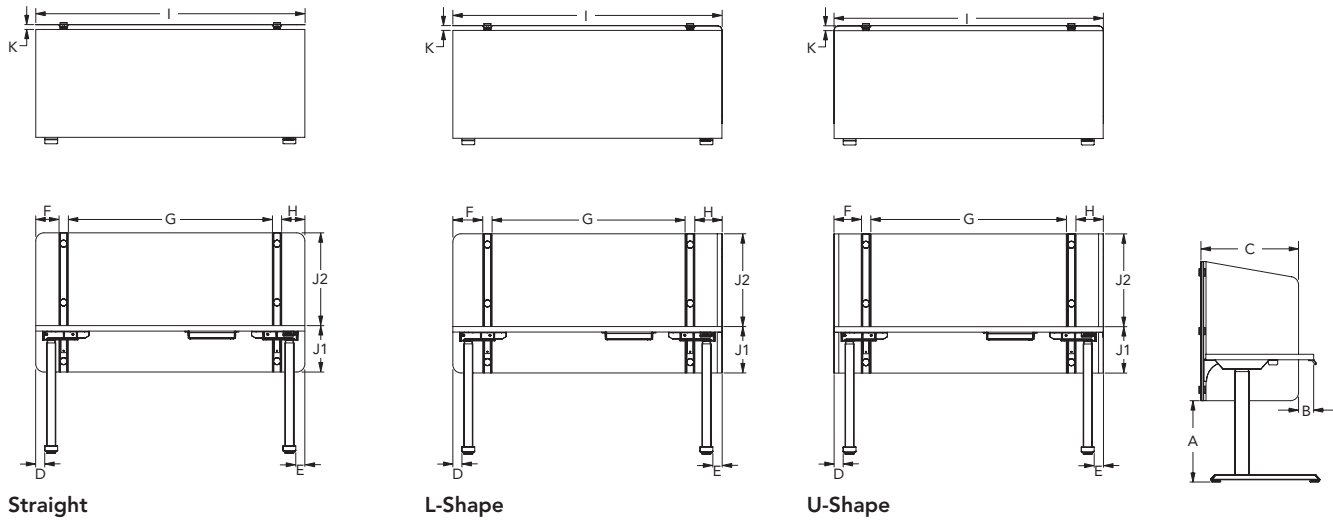

Size Reference Matrix

Models	A	B	C1	C2	D	E	F	G1	G2	H	I	J1	J2	K
	Under Desk Height	Wing to Front	Wing Width STD	Wing Width EXT	Left Leg to Edge	Right Leg to Edge	Left Side Panel to Support	Distance Between Supports	Distance Between Center/ Right Support	Right Side Panel to Support	Overall Width	Desktop To Base of Panel	Desktop To Top of Panel	Cable Drop Space
AMS2048LH	24.7	3.3	21.1	24.3	2.0	2.0	5.9	29.7	-	6.4	46.1	2.9	20.0	1.0
AMS2054LH	24.7	3.3	21.1	24.3	2.0	2.0	5.9	35.7	-	6.4	52.1	2.9	20.0	1.0
AMS2060LH	24.7	3.3	21.1	24.3	2.0	2.0	5.9	41.7	-	6.4	58.1	2.9	20.0	1.0
AMS2066LH	24.7	3.3	21.1	24.3	2.0	2.0	5.9	22.8	22.8	6.4	64.1	2.9	20.0	1.0
AMS2072LH	24.7	3.3	21.1	24.3	2.0	2.0	5.9	25.8	25.8	6.4	70.1	2.9	20.0	1.0
AMS2048RH	24.7	3.3	21.1	24.3	2.0	2.0	6.4	29.7	-	5.9	46.1	2.9	20.0	1.0
AMS2054RH	24.7	3.3	21.1	24.3	2.0	2.0	6.4	35.7	-	5.9	52.1	2.9	20.0	1.0
AMS2060RH	24.7	3.3	21.1	24.3	2.0	2.0	6.4	41.7	-	5.9	58.1	2.9	20.0	1.0
AMS2066RH	24.7	3.3	21.1	24.3	2.0	2.0	6.4	22.8	22.8	5.9	64.1	2.9	20.0	1.0
AMS2072RH	24.7	3.3	21.1	24.3	2.0	2.0	6.4	25.8	25.8	5.9	70.1	2.9	20.0	1.0
AMS3248LH	17.5	3.3	21.1	24.3	2.0	2.0	5.9	29.7	-	6.4	46.1	10.0	20.0	1.0
AMS3254LH	17.5	3.3	21.1	24.3	2.0	2.0	5.9	35.7	-	6.4	52.1	10.0	20.0	1.0
AMS3260LH	17.5	3.3	21.1	24.3	2.0	2.0	5.9	41.7	-	6.4	58.1	10.0	20.0	1.0
AMS3266LH	17.5	3.3	21.1	24.3	2.0	2.0	5.9	22.8	22.8	6.4	64.1	10.0	20.0	1.0
AMS3272LH	17.5	3.3	21.1	24.3	2.0	2.0	5.9	25.8	25.8	6.4	70.1	10.0	20.0	1.0
AMS3248RH	17.5	3.3	21.1	24.3	2.0	2.0	6.4	29.7	-	5.9	46.1	10.0	20.0	1.0
AMS3254RH	17.5	3.3	21.1	24.3	2.0	2.0	6.4	35.7	-	5.9	52.1	10.0	20.0	1.0
AMS3260RH	17.5	3.3	21.1	24.3	2.0	2.0	6.4	41.7	-	5.9	58.1	10.0	20.0	1.0
AMS3266RH	17.5	3.3	21.1	24.3	2.0	2.0	6.4	22.8	22.8	5.9	64.1	10.0	20.0	1.0
AMS3272RH	17.5	3.3	21.1	24.3	2.0	2.0	6.4	25.8	25.8	5.9	70.1	10.0	20.0	1.0
AMS2048US	24.7	3.3	21.1	24.3	2.0	2.0	5.9	30.3	-	5.9	46.1	2.9	20.0	1.0
AMS2054US	24.7	3.3	21.1	24.3	2.0	2.0	5.9	36.3	-	5.9	52.1	2.9	20.0	1.0
AMS2060US	24.7	3.3	21.1	24.3	2.0	2.0	5.9	42.3	-	5.9	58.1	2.9	20.0	1.0
AMS2066US	24.7	3.3	21.1	24.3	2.0	2.0	5.9	23.1	23.1	5.9	64.1	2.9	20.0	1.0
AMS2072US	24.7	3.3	21.1	24.3	2.0	2.0	5.9	26.1	26.1	5.9	70.1	2.9	20.0	1.0
AMS3248US	17.5	3.3	21.1	24.3	2.0	2.0	5.9	30.3	-	5.9	46.1	10.0	20.0	1.0
AMS3254US	17.5	3.3	21.1	24.3	2.0	2.0	5.9	36.3	-	5.9	52.1	10.0	20.0	1.0
AMS3260US	17.5	3.3	21.1	24.3	2.0	2.0	5.9	42.3	-	5.9	58.1	10.0	20.0	1.0
AMS3266US	17.5	3.3	21.1	24.3	2.0	2.0	5.9	23.1	23.1	5.9	64.1	10.0	20.0	1.0
AMS3272US	17.5	3.3	21.1	24.3	2.0	2.0	5.9	26.1	26.1	5.9	70.1	10.0	20.0	1.0
AMS2048SS	24.7	-	-	-	2.0	2.0	5.0	32.0	-	5.0	46.0	2.9	20.0	1.0
AMS2054SS	24.7	-	-	-	2.0	2.0	5.0	38.0	-	5.0	52.0	2.9	20.0	1.0
AMS2060SS	24.7	-	-	-	2.0	2.0	5.0	44.0	-	5.0	58.0	2.9	20.0	1.0
AMS2066SS	24.7	-	-	-	2.0	2.0	5.0	24.0	24.0	5.0	64.0	2.9	20.0	1.0
AMS2072SS	24.7	-	-	-	2.0	2.0	5.0	27.0	27.0	5.0	70.0	2.9	20.0	1.0
AMS3248SS	17.5	-	-	-	2.0	2.0	5.0	32.0	-	5.0	46.0	10.0	20.0	1.0
AMS3254SS	17.5	-	-	-	2.0	2.0	5.0	38.0	-	5.0	52.0	10.0	20.0	1.0
AMS3260SS	17.5	-	-	-	2.0	2.0	5.0	44.0	-	5.0	58.0	10.0	20.0	1.0
AMS3266SS	17.5	-	-	-	2.0	2.0	5.0	24.0	24.0	5.0	64.0	10.0	20.0	1.0
AMS3272SS	17.5	-	-	-	2.0	2.0	5.0	27.0	27.0	5.0	70.0	10.0	20.0	1.0

ALTITUDE

Altitude — Metal Screens (page 276)

- Powder coated magnetic metal privacy screen.
- Metal surfaces can be easily disinfected with cleaners. See cleaning guide for more details at AllsteelOffice.com.
- Available in all standard paint colors.
- Provides 1" gap along the back for accessory mount and cord drop.
- Available in 48"W, 54"W, 60"W, 66"W and 72"W.
- 66"W and 72"W screens include 3rd center bracket.
- Available in Straight, L- and U-shape configurations. Above and Above/Below desk applications.
- L- and U-Shape screens are not compatible with shrouded Height Adjustable Table legs.
- Optional tackable accessories specified separately.
- 66"W tackable accessory comes as a set of (2) 24"W.
- 72"W tackable accessory comes as a set of (2) 20"W.
- Available in standard and extended wings.
- Wings mount flush to the edge of the surface with an L-Bracket.
- 20"W tackable accessory must only be applied to both standard and extended wings without accessory slots.
- Wings are available with accessory slots that accept Radii Hot File, Side Saddle and Coat hook.
- Top slot can accept one Radii accessory.
- Bottom slot can accept a Coat hook and one other accessory.
- Accessories can hang on either side of the wing.
- TIP: If the Hot File is used in the top slot, it will block access for accessories in the bottom slot.
- Do not hang more than 5lbs of weight on wings.
- Screens are compatible with Radii undermount storage.
- Not compatible with standard 120-worksurfaces. Contact Allsteel TPG for custom sizes.
- When using a 24"D worksurface with Altitude screens, you must specify a T-foot.

Size Reference Matrix

Tackboards	Wing	48"W	54"W	60"W	66"W	72"W
Actual Dimensions	20"W	30"W	36"W	42"W	20"W	24"W
Set of Tackboards	1	1	1	1	2	2

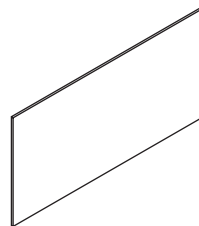

Accessories — Tackboard (page 277)

- Tackable accessories come with metal frame available in standard paint colors and fabric options.
- Attach to the screen using a dual lock tape (included in hardware).

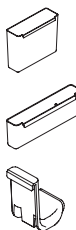

Accessories — Radii (page 277)

- Wings are available with accessory slots that accept Radii Hot File, Side Saddle and Coat hook.
- Top slot can accept one Radii accessory.
- Bottom slot can accept a Coat hook and one other accessory.
- Accessories can hang on either side of the wing.
- TIP: If the Hot File is used in the top slot, it will block access for accessories in the bottom slot.

Accessories — Further Worksurface Rail Mount (page 283)

- Accessory rail must be field cut to fit between the screen brackets.
- The following accessories are not compatible with screens: U9WTC and U9TM.

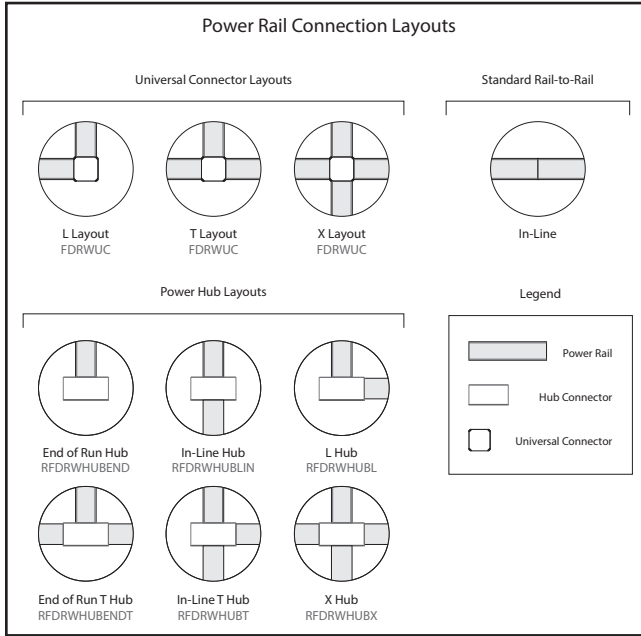

GENERAL OVERVIEW

- Accommodates power and lay-in capacity for data cables.
- Available in 48", 54", 60", 66", and 72" lengths.
- Maximum of 2 duplexes and 2 data ports per side of rail.
- Models come equipped with hardware for in-line connections.
- Fiber optic cables can follow 90 degree turns at the intersection of the power rails.
- Power harnesses snap into electrical brackets within the power rail and accept duplex receptacles.
- Electrical power harness accepts up to 2 duplex receptacles per side of rail.
- End caps are required at an end-of-run, unless connected to an end-of-run power pole or a hub.
- Power rail can be set low to the floor using the floor legs or raised off the floor at 20½" H with elevated legs.

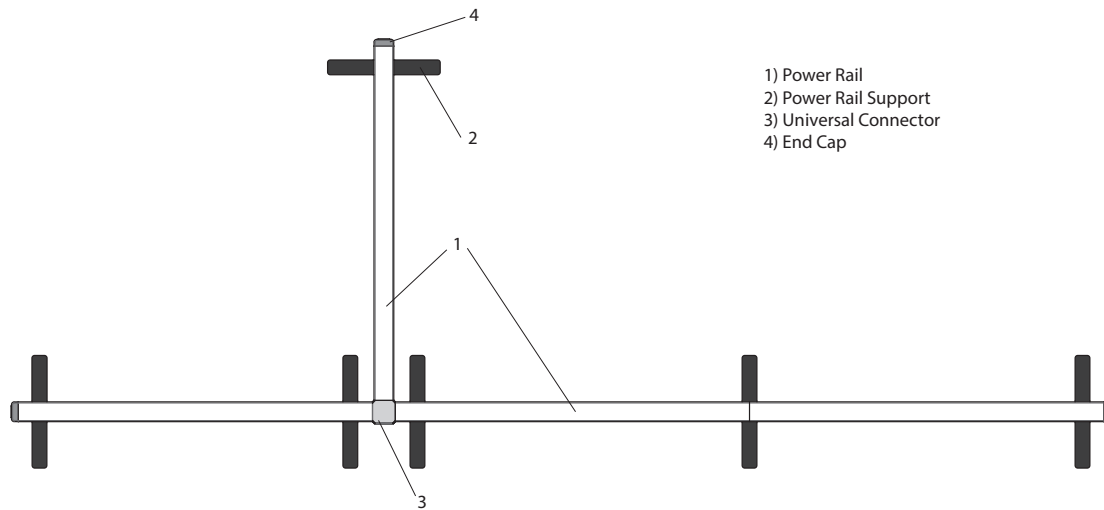

- 1) Power Rail
- 2) Power Rail Support
- 3) Universal Connector
- 4) End Cap

ALTITUDE

Power Rail Typicals

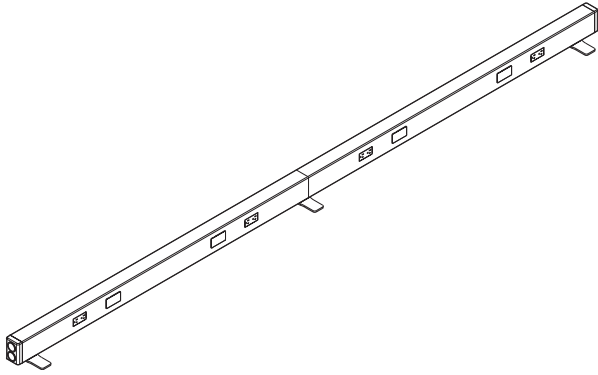

Low Rail, (2) 60"W Rail
Linear Configuration

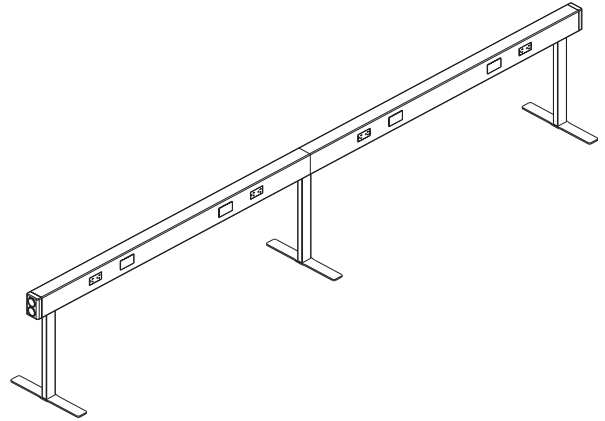

Raised Rail, (2) 60"W Rail
Linear Configuration

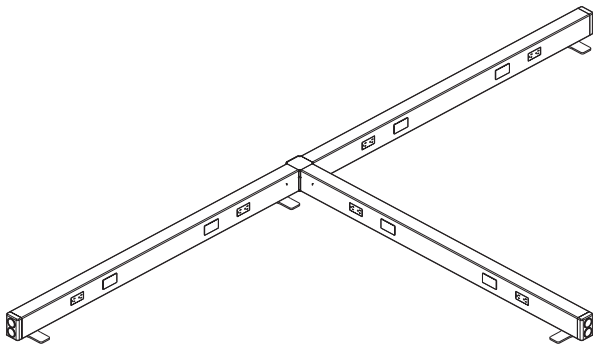

Low Rail, (3) 60"W Rail
T-Configuration

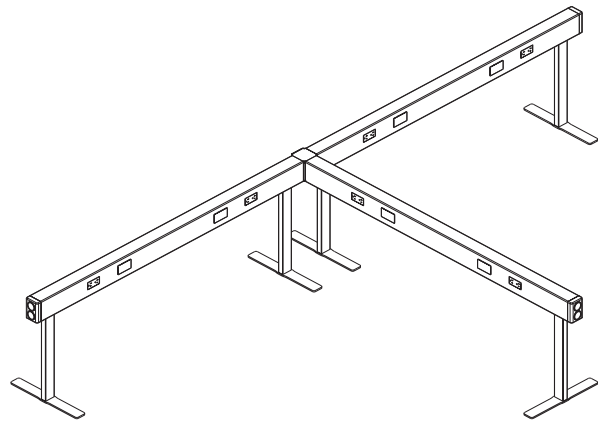

Raised Rail, (3) 60"W Rail
T-Configuration

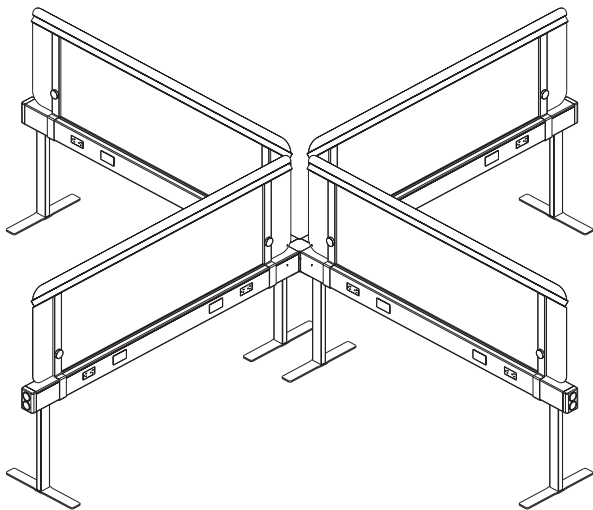

Raised Rail, (4) 60"W Rail
X-Configuration with Screens

WORKING WITH ALTITUDE POWER RAILS

Low Rail with Floor Legs:

- Each power rail is supported by (2) floor legs.
- Floor legs have a leveling mechanism that can adjust up to 1¼"H.
- Legs are specified separately and come in qty of 1. Each leg is 7¼"D x 2¼"W.
- Leg is inset 2.8" from end of the power rail.
- Universal connector allows "L", "T" and "X" configurations.
- Can connect directly to another power rail in linear applications without use of the universal connector.
- Cannot mount screens on the low rail.
- Power infeed can access the power rail in multiple ways:
 - through a receptacle position on the power rail (side infeed).
 - through the end cap on to the first power block.
 - through power pole using a power pole connector kit.

Raised Rail

- Power rails can be raised up to 20½"H using Elevated Legs and/or Hubs.
- Elevated Legs and Hubs can be used in conjunction to create the desired capability and aesthetic.
- Can be in Linear, L-, T- or X-configurations using Elevated Legs, Hubs or Universal Connector.
- Supports screens. See screens section for more details.
- Elevated Legs
 - Inset 2.8" from end of the power rail.
 - Can be shared in between the two rails in linear configuration.
 - Cannot route power and/or data.
 - Specified separately and come in qty of 1. Foot is included.
 - Leg is 15¼"D x 2¼"W x 17¾"H.
 - Order RFDRAWAB separately to anchor to floor. Appropriate fasteners per floor type sourced locally.
- Support Hubs
 - Connect directly to the power rail.
 - Can be shared in between the two rails.
 - L-, T- and X-hubs can be shared in between power rails.
 - End of Run hub is only specified at end condition.
 - Can route power and/or data.
 - Can integrate power pole. Power Pole connector kit is specified separately and come in qty of 1. Foot is included.

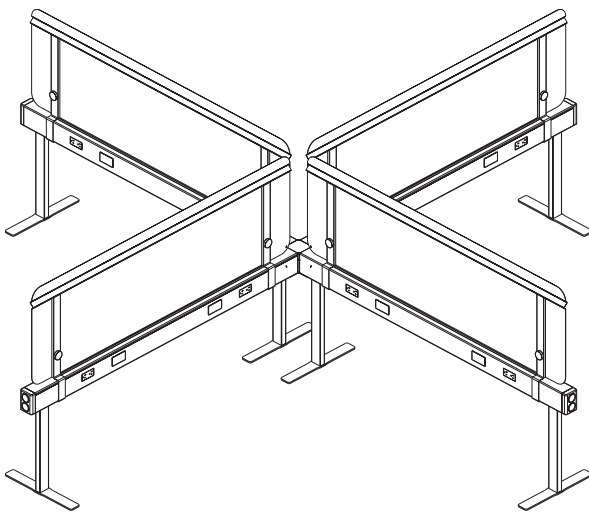

Screens

- Constructed of painted steel material.
- Standard Allsteel paint options can be applied.
- Screen height is 20"H, provides overall height of 42"H above fixed floor.
- Painted steel is magnetic and cleanable. Refer to cleaning solutions page at Allsteel Office website.
- Attachment hardware included.

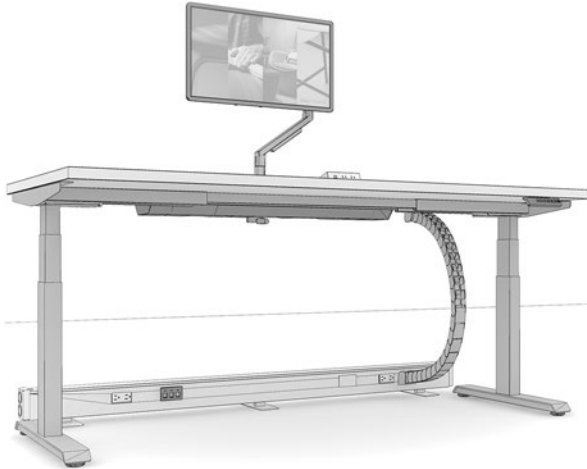

Altitude Desk + 60"W Low Rail + WKSWMC

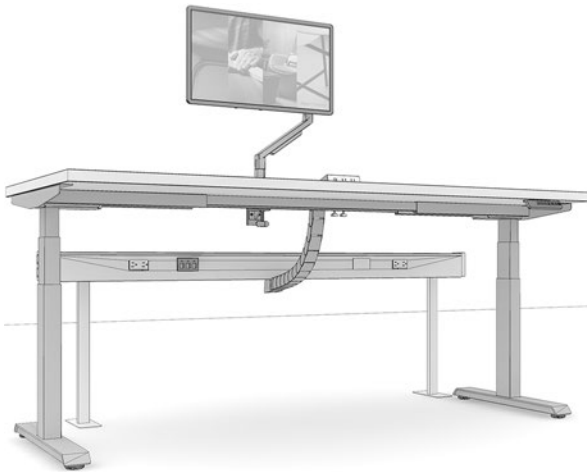

Altitude Desk + 60"W Raised Rail + A9CLWMC

WORKING WITH CABLE MANAGEMENT

- Used to route and conceal power/data cables from control box and other devices. Includes all mounting hardware.
- Houses 6 cables @ 0.300" diameter.
- Specify WKSWMC for 58" chain. Only comes in Black Finish. Recommended for use with Low Rail.
- Specify A9CLWMC for 36" chain. Comes in Black, White and Silver. Recommended for use with Raised Rail.
- Links the power rail to a height adjustable desk.
- Has two connecting points: Top section connects underneath the Height Adjustable Desk and the bottom section connects underneath the power rail using a double-sided tape. Hardware included.
- When mounting the chain to underneath the rail, an adapter link is required. Included in the hardware.

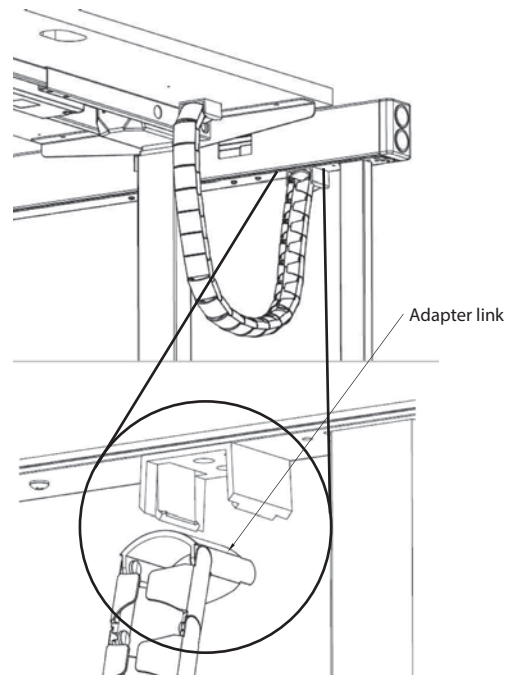

ALTITUDE

WORKING WITH POWER RAIL ELECTRICALS

General Notes about Electrical and Circuitry:

- Power Rail offers a choice of four electrical systems:
 - Four-circuit, 3 + 1
 - Four-circuit, 2 + 2
 - Three-circuit, separate neutrals
 - Eight circuits; two four-circuit systems provided back to back.
 - See Altitude Pricer section “Working with Electrical” for a detailed explanation of each electrical system.
 - All four systems utilize an 8-wire electrical system, rated at 20 amps.
- Per circuit (15 amps Canadian) — 16 amps plannable in U.S.
 - Power Rail and electrical components are UL Listed. Electrical
- Components are also CSA certified.
 - Installation and use of the electrical system, the number of receptacles.
- Used on a given circuit and connections to the building power supply.
- Should follow all local and national electrical codes.

Electrical Infeeds

- Power infeed cables deliver power from building to panel's electrical system.
- Infeed cables are housed in conduit to separate electrical system from communications and data lines.
- Select quantity of base or ceiling infeed cables depending on individual power requirements.
- Refer to rail supports for infeed access points.

Routing Power

- Power infeed can access the raised power rail in multiple ways:
 - Through power pole using a power pole connector kit.
 - Through Support Hubs.
 - Through the infeed vertebrae.

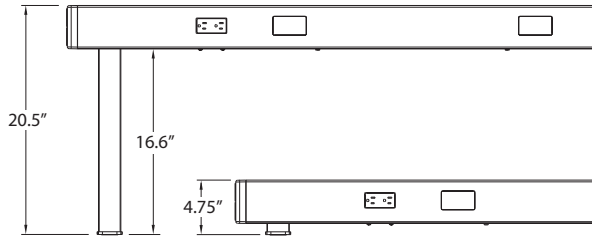

Raised Rail & Low Rail

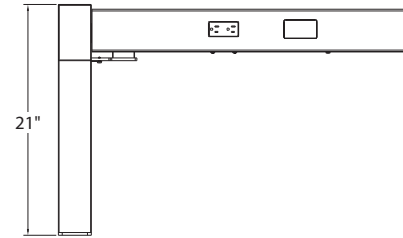

End of Run Hub

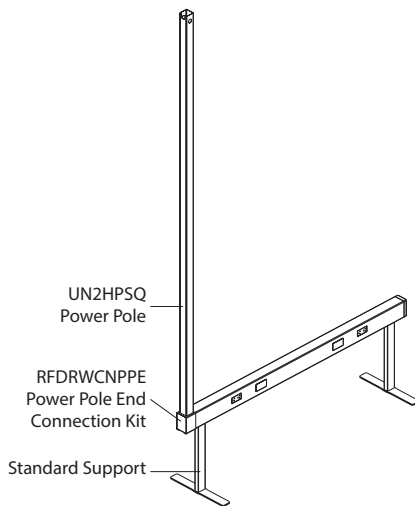

RFDRWCNPPE + UN2HPSQ
Connected to 60" W Rail

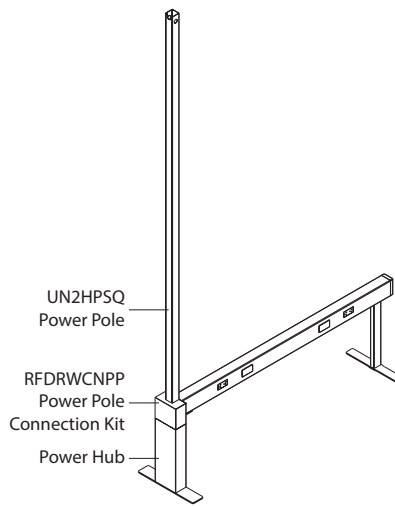

RFDRWHUBEND + RFDRWCNPP
UN2HPSQ connected to 60" W Rail

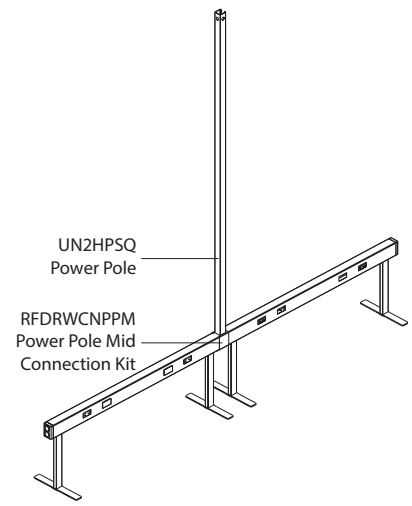

UN2HPSQ + RFDRWCNPPM
Connected to 60" W Rail

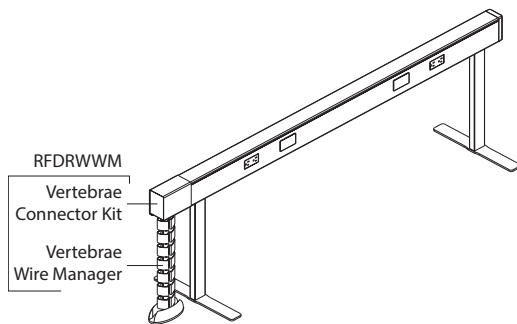

RFDRWWM
Connected to 60" W Rail

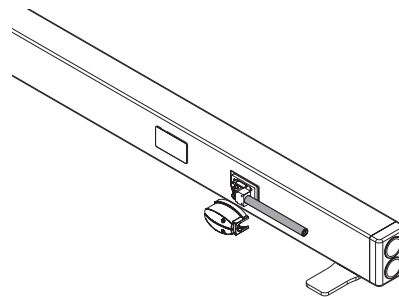

A876072 Infeed
Connected to 60" W Rail through
Receptacle Knockout

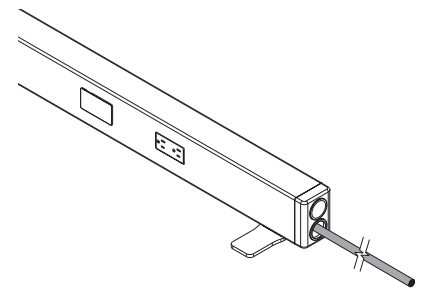

A877012 Infeed
Connected to 60" W Rail through End Cap

Electrical Systems

General Notes about Electric, Circuitry, and Chicago Code:

- Power Rail offers a choice of four electrical systems:
 - Four-circuit, 3 + 1
 - Four-circuit, 2 + 2
 - Three-circuit, separate neutrals
 - Eight circuits; two four-circuit systems provided back to back.
- See pages 258-259 for a detailed explanation of each electrical system.
- All four systems utilize an 8-wire electrical system, rated at 20 amps per circuit (15 amps Canadian) — 16 amps plannable in U.S.
- Power Rail and electrical components are UL Listed. Electrical components are also CSA certified.
- Installation and use of the electrical system, the number of receptacles used on a given circuit and connections to the building power supply should be in compliance with all local and national electrical codes.

Caution: Electrical equipment cords or extension cords MUST NOT BE ROUTED through cable openings in frame sides.

Note: No more than one conduit that is connected to a harness mounted to horizontal can be routed through the same cut out in the same horizontal at beltline. Attempting to use more will cause binding of conduit and may affect reveals on receptacles.

Hardwire New York Code (page 273)

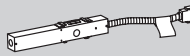
- Hardwire (New York Code) junction box (model A871400) is used when local electrical codes require hardwire entry. 
- For use in panels 48" W to 72" W.
- Unit must connect to a power harness.
- Customer to furnish all cabling and wiring from power entry to power source.
- Junction box can be positioned at any duplex receptacle location.
- For NY infeed through the end cap:
 - Order 24" pass-thru harness with power block A871124.
 - Will not have power at first cut-out from infeed.
- For NY infeed through a power rail cut-out:
 - Order 48"-72" pass-thru harness with power block. *Harness width must match power rail width.*
 - Will not have power at cut-out location used for infeed.
- For any power rail not used for infeed, order standard electrical power harness.

Hardwire Chicago Code (page 274)

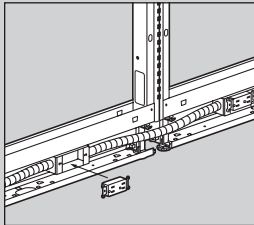
- Wiring harnesses and snap connectors are not allowed in Chicago — base pathways must be comprised of all-metallic components.
- The base pathway, junction box (model 873600) clips directly into receptacle locations and can be used both single- and double-sided.
- Customer must furnish conduit, wiring, and designer-type receptacles for the base pathway and conduit, wiring, designer-type receptacles, and receptacle covers for the beltline.
- Power entry can be routed from the floor into a junction box (model 873600). 

Electrical Infeeds

- Power infeed cables deliver power from building to panel's electrical system.
- Infeed cables are housed in conduit to separate electrical system from communications and data lines.
- Select quantity of base or ceiling infeed cables depending on individual power requirements.

Base Infeed (page 273)

- Sealtight base pathway power infeed mounts into any receptacle position in the base pathway area.
- A heavy rubber sheathing shields conduit, allowing infeed to be exposed.
- A jumper is required to connect base pathway power to beltline.

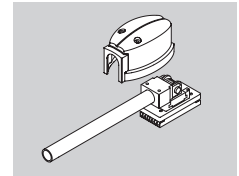

Sealtight Electrical Infeed (page 273)

- Sealtight electrical infeed cable is used with footed panels.
- Should not be ordered prior to installation to have pre-wired as infeed must be routed from inside of panel out to be connected to power.
- Cannot be connected to power harness in panel frame that infeed is brought into unless additional pass-thru harness without power block is used to feed from below beltline to above beltline.

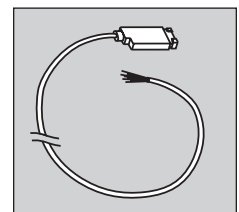

Power Infeed (page 273)

- Power infeed connects to a prewired electrical harness in the power rail.
- Most codes allow flex conduit to be exposed after installation. Verify code requirements before ordering for exposed application.

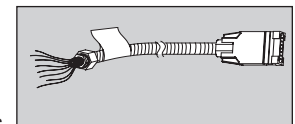

To Order:

- Determine which electrical system you will use after consulting your electrician and computer support personnel:
 - The Four-circuit system (4-Hot/2-Neutral/2-Ground)
 - 3 + 1 option
 - 2 + 2 option
 - The three-circuit system (3-Hot/3-Neutral/2-Ground)
 - The eight-circuit system (back-to-back four-circuit systems)
- Determine location, quantity, and circuit of duplexes.
- Determine the appropriate choice and use of isolated, isolated/dedicated, and separate neutrals circuits.
- Specify appropriate power harnesses* and pass-thru cables.*
- Determine the location, quantity, and type of power infeed needed.

* Select power harness models (A8712XX), with the last two digits corresponding with the panel width into which the component is to be positioned.
The initial cable length can be stretched approximately 3" to transverse "T", "X", "L", and extended straight connectors.

Flexconnect™ Electrical System Options

The four-circuit, eight-wire electrical system is widely specified and trusted by hundreds of thousands of end-users. This proven system delivers four circuits for every power infeed in either a 3 + 1 or 2 + 2 configuration. The isolated/dedicated circuits are ideal for sensitive computing equipment, while the common circuits are suitable for faxes, copiers, task lights and other peripherals. Both the 3 + 1 and 2 + 2 systems use the same pre-wired components, making it easy to adjust as electrical needs change.

You can also choose a three-circuit, eight-wire system that has a dedicated neutral for every hot circuit. The three-circuit components have model numbers with an "A" suffix and appear in a gray box in this price.

All three systems utilize an eight-wire electrical system rated at 20 amps per circuit (15 amps Canadian). Concensys panels and electrical components are UL listed and CSA certified.

Four-circuit, 3 + 1 Receptacle Option

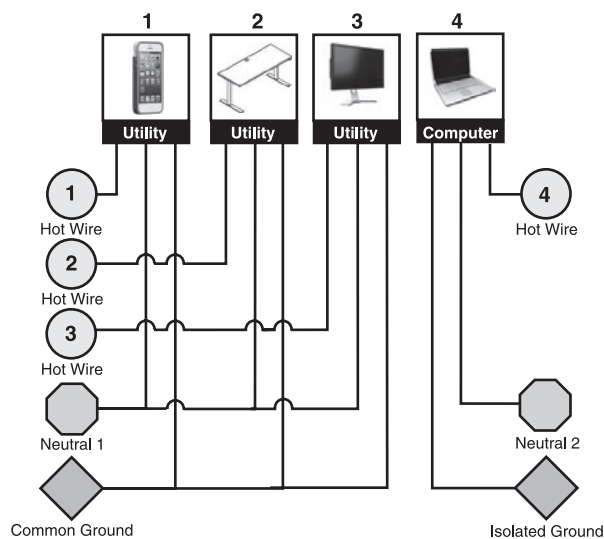

The 3 + 1 option is the electrical standard used on Allsteel systems for many years in most installations. This wiring option provides three utility circuits plus an isolated/dedicated circuit for more sensitive equipment. Circuit 2 (one of the 3 common circuits sharing a neutral wire) cannot be used with single-phase building electrical supply.

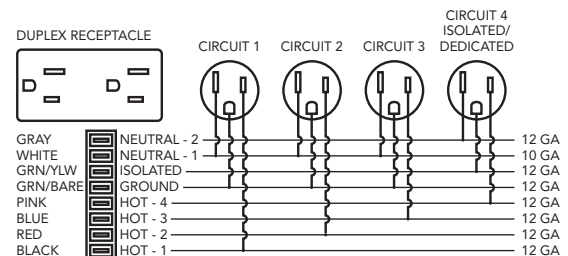

Four-circuit, 2 + 2 Receptacle Option

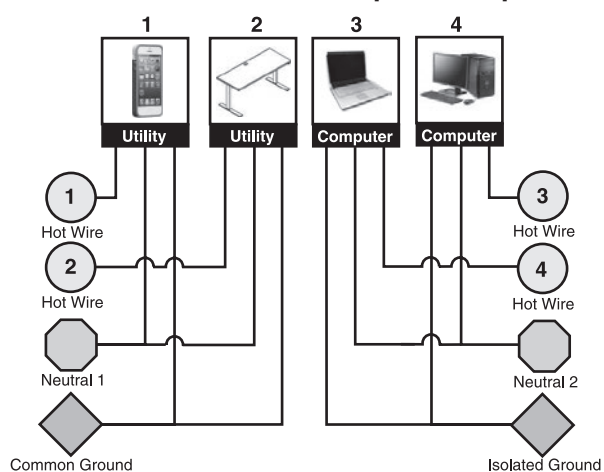

The 2 + 2 option is a wiring option that provides two utility circuits and two isolated circuits for more extensive computer usage applications.

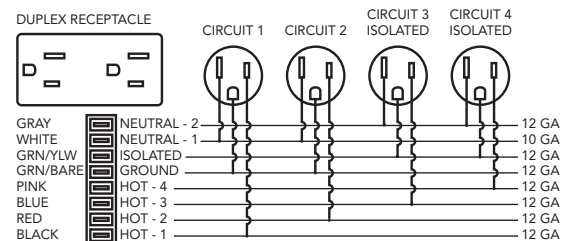

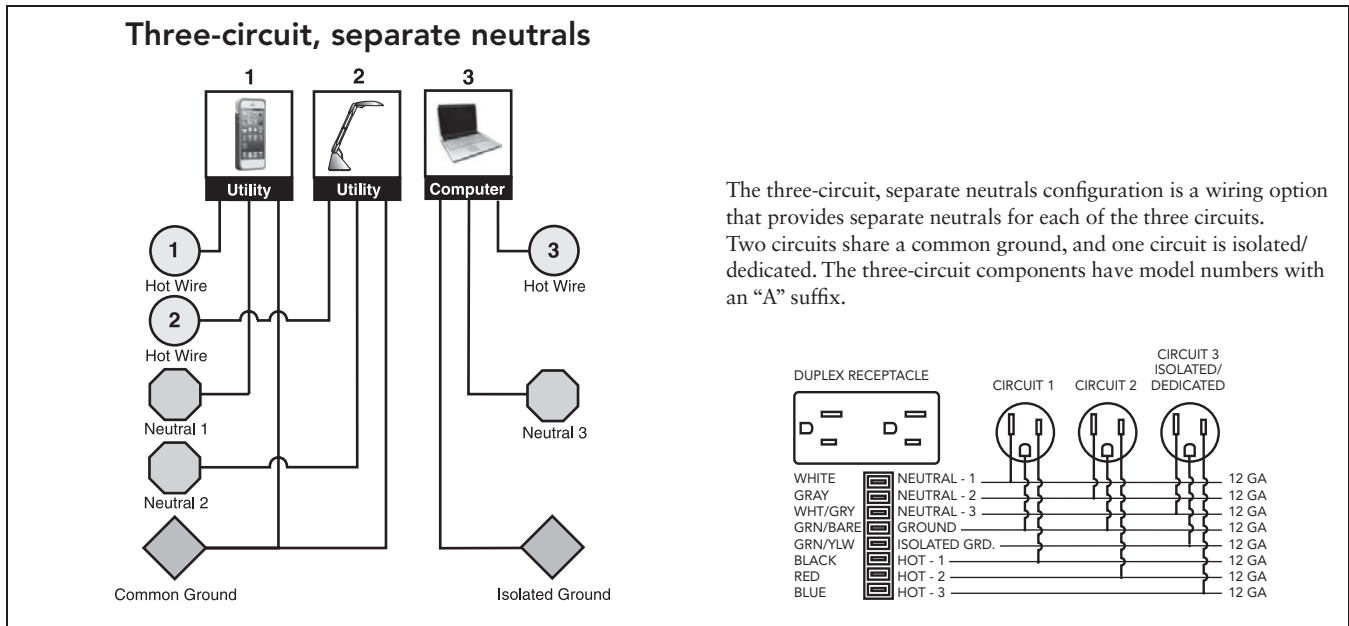

Altitude System Receptacle Usage					
Two 8-wire, 20 amp (15 amp Canadian) electrical systems are offered					
Electrical System	Circuitry	Receptacle Capacity			
Four-circuit 4-Hot/2-Neutral/2-Ground	3 + 1	Common Circuit-1 A873501	Common Circuit-2 ⁽¹⁾ A873502	Common Circuit-3 A873503	Iso/Dedicated Circuit-4 A873504
	2 + 2	Common Circuit-1 A873501	Common Circuit-2 A873502	Isolated Circuit-3 A873506	Isolated Circuit-4 A873504
Three-circuit 3-Hot/3-Neutral/2-Ground	w/separate neutrals	Common Circuit-1 A871501A	Common Circuit-2 A871502A	Iso/Dedicated Circuit-3 A871503A	N/A

(1) Circuit 2 (one of the 3 common circuits sharing a neutral wire) cannot be used with a single-phase building electrical supply.

Notes:

- Four-circuit components and three-circuit components (with suffix "A") cannot be used together.
- Components of the two systems are keyed differently to prevent components of one system being connected to components of another system.
- Allsteel model numbers are printed on the UL labels, and components are color-coded to provide visual identification of the different components.
- Four-circuit components have black plastic parts.
- Three-circuit components have rust-colored terminal ends and receptacle backs are rust-colored.

Duplex Receptacle



15 amp receptacle

Infeeds

- Power infeed cables deliver power from building to Power Rail's electrical system.
- Infeed cables are housed in conduit to separate electrical system from communications and data lines.
- Select quantity of infeed cables depending on individual power requirements.

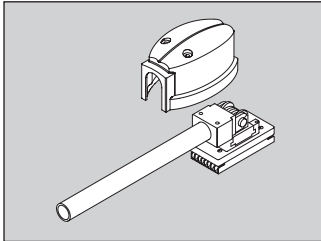

Base Infeed:

- Sealtight base pathway power infeed mounts into any receptacle position in the power rail housing.
- A heavy rubber sheathing shields conduit, allowing infeed to be exposed.

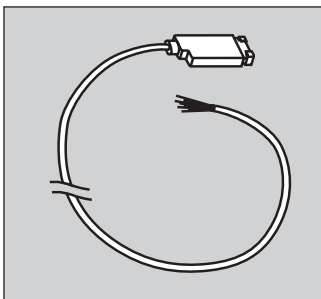

Sealtight Electrical Infeed:

- Sealtight electrical infeed is used for power entering through the end cap.
- Should not be ordered prior to installation to have pre-wired as infeed must be routed from inside of the power rail out to be connected to power.

Power Harness

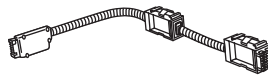

Electrical power harnesses are used to distribute power in the power rail. **Power blocks** on electrical power harness accept duplex receptacles.

- Electrical power harnesses are used to distribute power in Power Rails. Harnesses must be installed in each power rail housing.
- Specify harness length to match rail housing length. Each power harness accepts four duplex receptacles (two on each side of power rail housing).
- Connectors at both ends of power harnesses allow power distribution in either direction.
- Harness power blocks snap directly onto brackets in power rail housing.

Power Blocks

- Power blocks snap directly onto brackets in the power rail and accept receptacles (sold separately) on each side of harness.

Duplexes

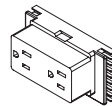

Duplex Receptacles

Receptacle Color Recommended to Coordinate with Paint Color

Paint Color	Receptacle Color
Bungalow — P7C	Muslin — EU
Champagne Metallic — PR5	Muslin — EU
Cinder — P7Q	Brownstone — EY
Fossil — P28	Flint — E9
Gunmetal Metallic — PR3	Brownstone — EY
Parchment — P93	Muslin — EU
Pebble — P8R	Loft — EV
Pewter — P8D	Flint — E9
Platinum — PR2	Loft — EV
Platinum Metallic — P42	Silver — E5
Salt — P8C	Silver — E5
Titanium — P8T	Silver — E5

- Duplex receptacles snap into power blocks of power harnesses.
- Duplexes are available in multiple colors. See inside front cover for finishes.
- Each receptacle is labeled to indicate which circuit it will be connected to: 1, 2, 3 or 4.
- Duplexes are model specific to support either 3 + 1 and 2 + 2 electrical infeed; or have an "A" suffix and are designed to support a three-circuit separate neutral electrical infeed.
- At least one duplex must be installed in upper housing side of rail housing assembly (see page 262, "Working with Electrical and Data").

Data

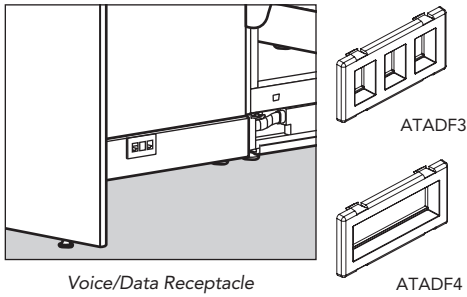

Data Faceplates:

- Fit into data port openings in Power Rail Housing.
- Due to rail housing depth, data modules should not be used back-to-back.

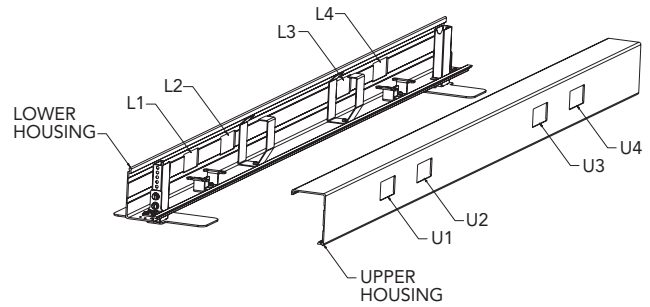

- Ports 1 and 4 accept duplexes, port covers and base infeeds.
- Ports 2 and 3 accept data and port covers.
- Either U1 or U4 must always contain a duplex.
- Data cannot be back-to-back (data in L2 + U2 or L3 + U3 combinations are not permitted).

Port Cover

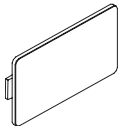

- Port covers must be used where no duplex or data faceplate is present.
- Fits into Power Rail port locations in place of duplex receptacles and data faceplates.
- Does not fit into port sizes of other product lines.

Cable Capacity

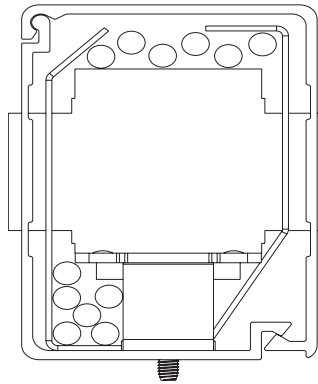

- The power rail housing allows continuous voice and data lines to run without interruption.
- Lay-in is provided for environments where systems furniture or cabling are subject to frequent change.
- Lower cavity allows 6 voice/data cables (1/4" dia).
- Upper cavity lay-in allows 6 voice/data cables (1/4" dia).

Power Rail Receptacle Locations

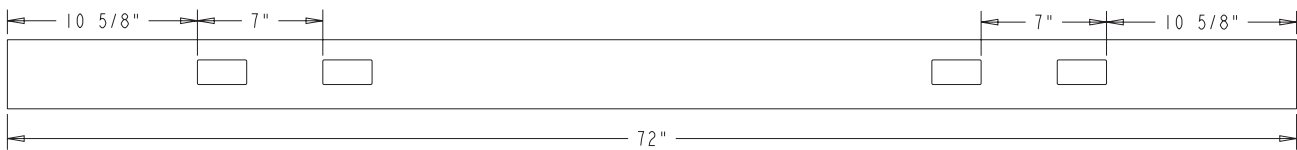
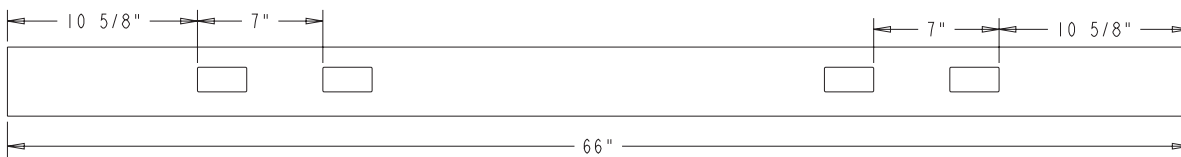
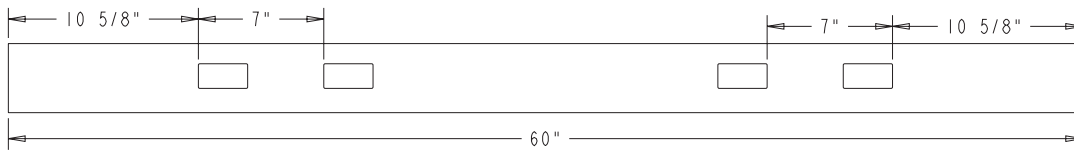
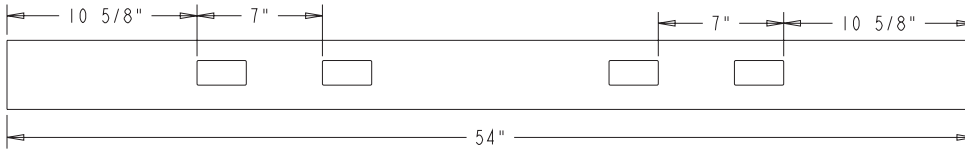
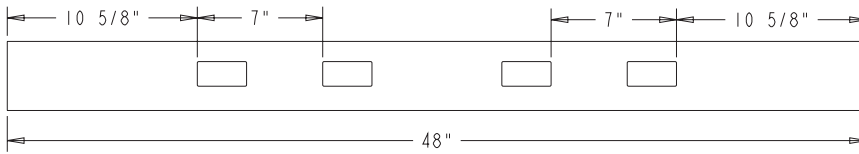

- For example, in a four-circuit system:
 - Circuit 1 — calculators, fans, etc.
 - Circuit 2 — task lights (could be wired to wall switch)
 - Circuit 3 — CRT or flat screen monitors
 - Circuit 4 — CPUs
- Use circuit 4 for power-sensitive electronic equipment.

Placement of pedestals and lateral files may render some duplex locations inaccessible. Pedestal placement may also affect compatibility with pull-up receptacles.

Height Adjustable Table Tie-In Brackets (Gallery Panels)

- Improves panel rigidity. Does not function as a panel stability solution.
- AGBKT to be specified for connection to a T leg HAT
- AGBKC to be specified for connection to a C leg HAT
- Reusable mounting template is required and must be ordered separately (AGBKTMP).
- Brackets telescope to account for 24" and 30" worksurface depths and screen attachments.
- A6 C legs with a 30"D worksurface and a screen must be specified with T leg brackets
- **Can be used with Altitude MAX bases when attaching to Gallery panels or Fit panels.**
- Height adjustable table brackets must be installed to both sides of the panel to substitute for a return panel in a dual-sided panel bench application. When a single bracket is connected to a wing panel as shown in the 4-pack image, the HAT bracket can substitute for a return panel.
- Freestanding panel can be connected to height adjustable table if it is supported by HAT brackets on both sides of the table and panel spine.

SINGLE BRACKET

Gallery Panel Application:

Max Height (with Glass): 65"H

Max Width: 75"W; No top size restrictions

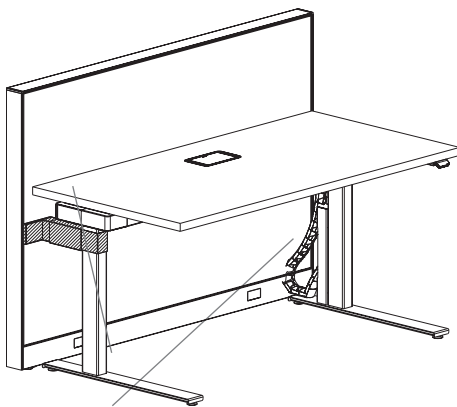
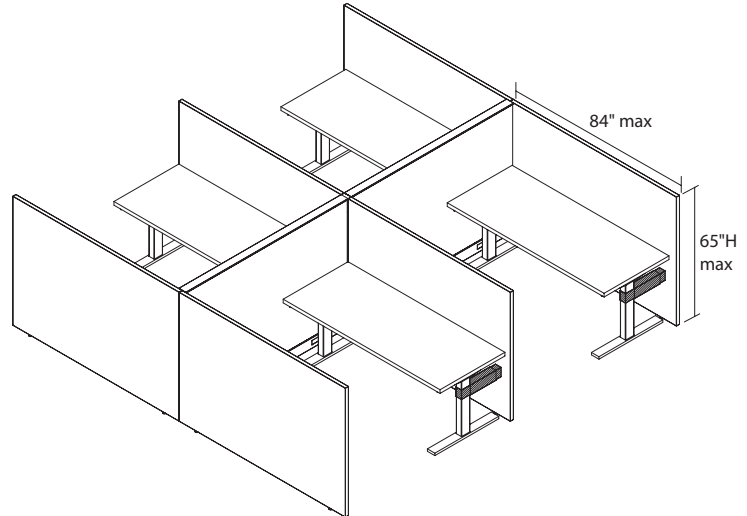

Note: Wire chain cannot be installed on the same leg as a HAT tie-in bracket.

DUAL SIDED PANEL BENCH

Gallery Panel Application:

Max Height (with Glass): 65"H

Bracket Needed: Single Panel (75" max) with Brackets on each leg (placed at the same height)

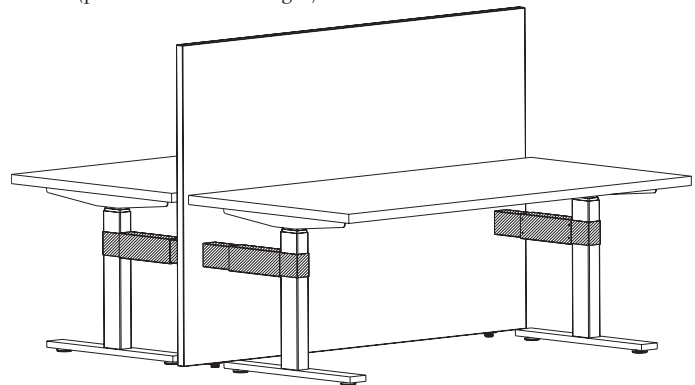

Freestanding Gallery Panel Application

Height Adjustable Table Tie-In Brackets (Optimize, Stride, and Terrace)

- Improves panel rigidity.
- ABKTL to be specified for connection to a LH T-leg HAT
- ABKTR to be specified for connection to a RH T-leg HAT
- ABKCL to be specified for connection to a LH C-leg HAT
- ABKCR to be specified for connection to a RH C-leg HAT
- Brackets mount into slotted standard.
- Brackets telescope to account for 24" and 30" worksurface depths and screen attachments.
- A6 C legs with a 30"D worksurface and a screen must be specified with T leg brackets
- NOT compatible with Altitude MAX bases
- Height adjustable table brackets must be installed to both sides of the panel to substitute for a return panel in a dual-sided panel bench application. When a single bracket is connected to a wing panel as shown in the 4-pack image, the HAT bracket can substitute for a return panel.
- Freestanding panel can be connected to height adjustable table if it is supported by HAT brackets on both sides of the table and panel spine for A8, A3, and A6.
- Dual sided A5 tables cannot support a freestanding panel. (A5 was discontinued on 12/31/2020)

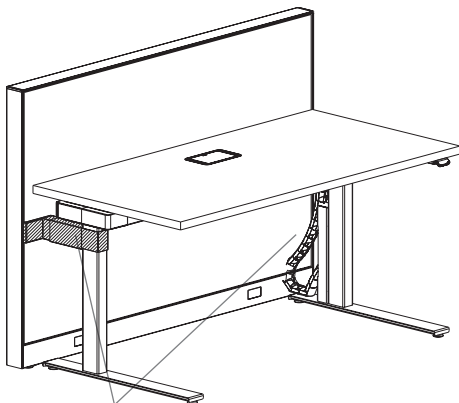

Note: Wire chain cannot be installed on the same leg as a HAT tie-in bracket.

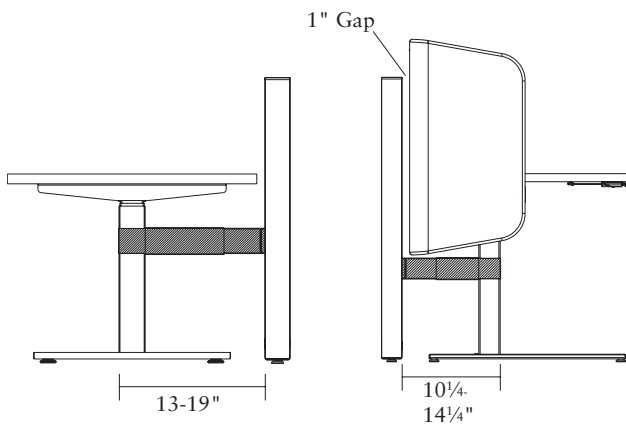

SINGLE BRACKET

Systems Application (not compatible with Concensys):

Max Height (with Glass): 65" H

Max Width: 96" W; Note: tops greater than 72" W will not align.

Overheads cannot be used without return panel

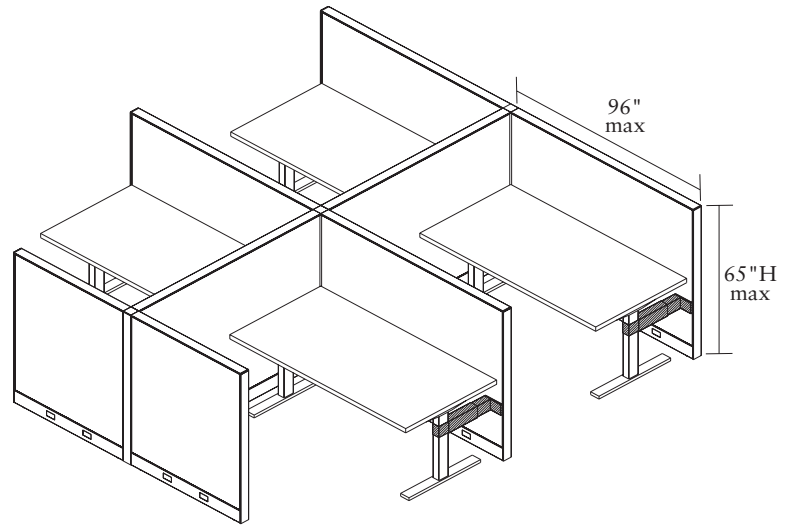

DUAL SIDED PANEL BENCH

Systems Application (not compatible with Concensys):

Max Height (with Glass): 65" H

Bracket Needed: Every 96" on both sides (placed at the same height).

Note: tops greater than 72" W will not align.

Overheads cannot be used without return panel

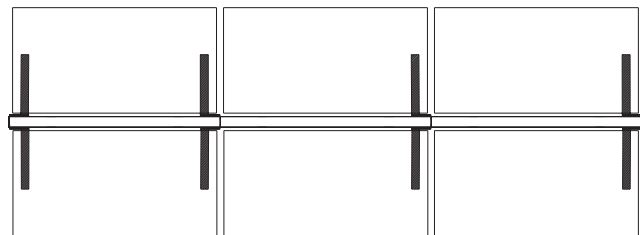
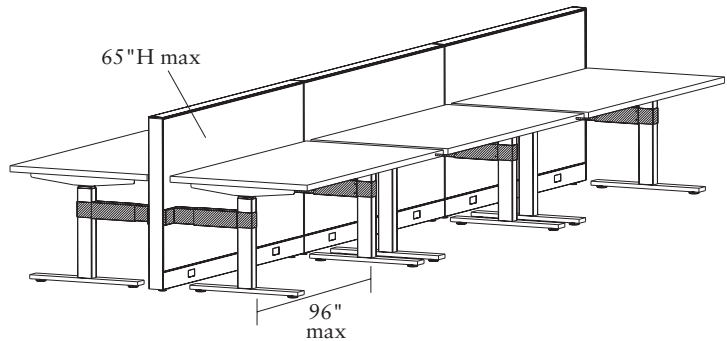

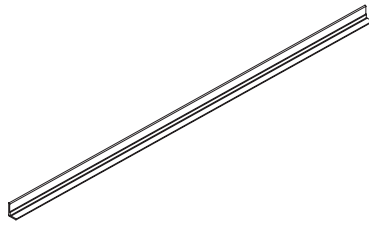

Rail Accessories

Side View



Top View

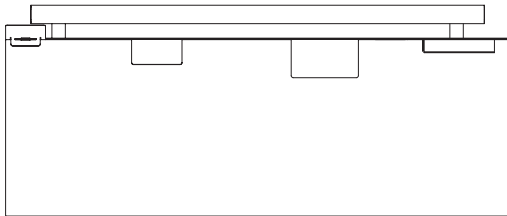

Phone/
Tablet
Stand

Pencil
Holder

Rail
Mounted
Shelf

Vertical
Paper Tray

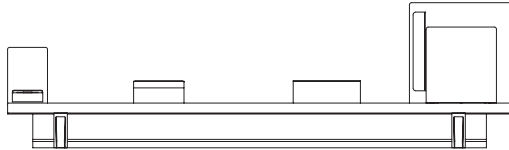

Front View

Worksurface Mounted Rail (page 283)

- Aluminum extrusion designed to mount to flat edge worksurfaces. Comes with rail and hardware for mounting.
- Mounted rail extends $\frac{3}{4}$ " on underside of worksurface which may interfere with the mounting of storage and screens.
- Widths available for Altitude tables 12" through 66" in 6" increments. Can pass across seams of ganged worksurfaces in tethered applications.
- Passes behind worksurface bracket on tethered applications.
- For freestanding applications rail should be 6" shorter than worksurface (i.e. 54" rail for 60" worksurface).

Rail Mounted Accessories

Not recommended for use on panel systems with attached worksurfaces due to fit up issues created with worksurface and panel. Adding accessory rail shifts worksurface $\frac{3}{8}$ " away from panel along that edge. Forcing worksurface into place crushes fabric tile and with tiles of other material (steel, marker board, etc) is likely to scratch, dent, or otherwise damage tile during installation.

U9TM Phone/Tablet Stand (page 283)

- $6\frac{1}{2}$ "H x $4\frac{3}{4}$ "W and angles back $1\frac{1}{4}$ ".
- Has a $\frac{1}{4}$ " x 1" slot in bottom flange to allow for routing cables. Requires $1\frac{1}{4}$ " space behind worksurface edge in order to be used.



U9TP Pencil Holder (page 283)

- $2\frac{3}{8}$ "H x 6"W x 3"D.
- Holds approximately twenty #2 pencils.



U9TS Rail Mounted Shelf (page 283)

- 8"W x $4\frac{1}{2}$ "D and sits $2\frac{3}{8}$ " higher than top of worksurface.
- Holds up to 8 pounds.

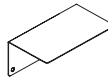

U9TF Vertical Paper Tray (page 283)

- Sits 12"H x $1\frac{1}{2}$ "W x 12"D from back of worksurface.
- Folder front stands 9" high from worksurface top, $1\frac{1}{4}$ " space holds about 280 sheets of copy paper.

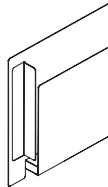

U9WTC Cord Organizer (page 283)

- Can attach to both bottom of worksurface or slides into rail.
- 4"W x $\frac{7}{8}$ "D, made from sheet metal.
- Top sits flush with worksurface if mounted to worksurface.
- 4 cable cut outs: 2 - .250" diameter and 2 - 0.147" diameter; .250" diameter cut outs are centered between the .147" diameter cut outs.



Universal Hook (page 283)

- Mounts to underside of worksurface and provides storage for bags, coats and purses. Can be used as a horizontal wire manager.

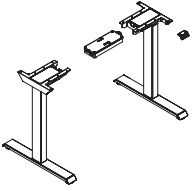
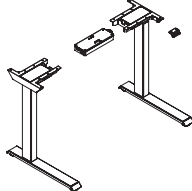
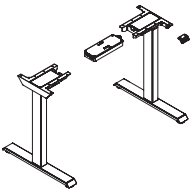
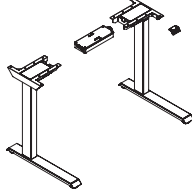
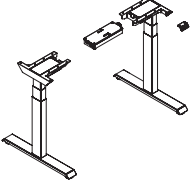
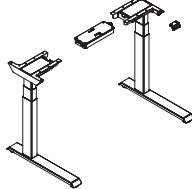

	Description	Model	List Price		
			P1	P2	P3
	2-Stage				
	2 Stage, 2 Leg Rectangle T Foot	A6REC2S2LTF	\$ 2151	\$ 2324	\$ 2582
	*Bases purchased in April 2021 or later accommodate 24"D-30"D Rectangular Worksurfaces 24"W-72"W, bases purchased prior to this date accommodate 24"D-30"D Rectangular Worksurfaces 48"W-72"W				
	2 Stage, 2 Leg Rectangle C Foot	A6REC2S2LCF	\$ 2151	\$ 2324	\$ 2892
	*Bases purchased in April 2021 or later accommodate 24"D-30"D Rectangular Worksurfaces 24"W-72"W, bases purchased prior to this date accommodate 24"D-30"D Rectangular Worksurfaces 48"W-72"W				
	3-Stage				
	A6 3 Stage, 2 Leg Rectangle T Foot	A6REC3S2LTF	\$ 2413	\$ 2607	\$ 2897
	*Bases purchased in April 2021 or later accommodate 24"D-30"D Rectangular Worksurfaces 24"W-72"W, bases purchased prior to this date accommodate 24"D-30"D Rectangular Worksurfaces 48"W-72"W				
	A6 3 Stage, 2 Leg Rectangle C Foot	A6REC3S2LCF	\$ 2413	\$ 2607	\$ 2897
	*Bases purchased in April 2021 or later accommodate 24"D-30"D Rectangular Worksurfaces 24"W-72"W, bases purchased prior to this date accommodate 24"D-30"D Rectangular Worksurfaces 48"W-72"W				
	A6 Max 3 Stage, 2 Leg T Foot	A6MREC3S2LTF	\$ 3349	\$ 3617	\$ 4020
	*Bases purchased in April 2021 or later accommodate 24"D-30"D Rectangular Worksurfaces 24"W-96"W, bases purchased prior to this date accommodate 24"D-30"D Rectangular Worksurfaces 48"W-96"W				
	*350 LB Max Lift Capacity				
	A6 Max 3 Stage, 2 Leg C Foot	A6MREC3S2LCF	\$ 3349	\$ 3617	\$ 4020
	*Bases purchased in April 2021 or later accommodate 24"D-30"D Rectangular Worksurfaces 24"W-96"W, bases purchased prior to this date accommodate 24"D-30"D Rectangular Worksurfaces 48"W-96"W				
	*350 LB Max Lift Capacity				

ALTITUDE

<p>How to specify — Select the Model Number from above.</p>	<p>1st Option: Select the Base Paint Color (if applicable): P1 P2 P3 See page 240 for paint finishes.</p>	<p>2nd Option: Select Feet Options (if applicable): X Standard Glides S Slide Glides (\$153 extra)</p>	<p>3rd Option: Select the Keypad (if applicable): UD Basic Up/Down MEM Memory Preset PDL Paddle</p>
--	--	---	--

Example: A6RND3S2LCF.P8L.X.PDL

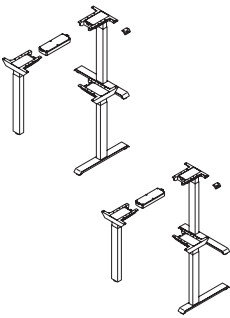
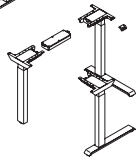
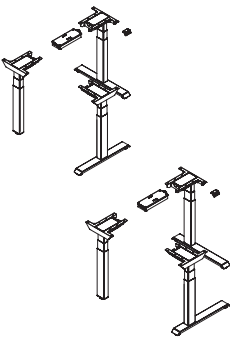
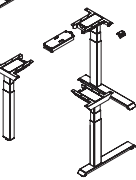
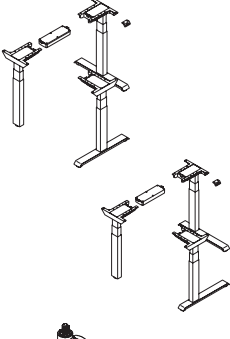
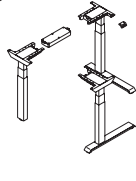
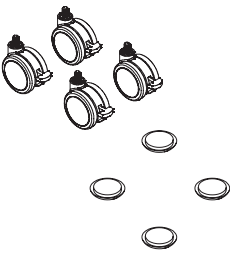
	Description	Model	List Price		
			P1	P2	P3
	2-Stage				
	A6 2 Stage, 3 Leg Rectangle T Foot	A6REC2S3LTF	\$ 3480	\$ 3829	\$ 4351
	A6 2 Stage, 3 Leg Rectangle C Foot	A6REC2S3LCF	\$ 3480	\$ 3829	\$ 4351
	3-Stage				
	A6 3 Stage, 3 Leg Rectangle T Foot	A6REC3S3LTF	\$ 3792	\$ 4096	\$ 4552
	*3-leg standard bases can accommodate worksurface configurations from 24"D x 48"W x 36"W to 30"D x 72"W x 48"W.				
	A6 3 Stage, 3 Leg Rectangle C Foot	A6REC3S3LCF	\$ 3792	\$ 4096	\$ 4552
	*3-leg standard bases can accommodate worksurface configurations from 24"D x 48"W x 36"W to 30"D x 72"W x 48"W.				
	A6 Max 3 Stage, 3 Leg Rectangle T Foot	A6MREC3S3LTF	\$ 4378	\$ 4817	\$ 5473
	*3-Leg Max bases can accommodate worksurface configurations from 24"D x 48"W x 36"W to 30"D x 72"W x 72"W. *500 lb Max Lift Capacity				
	A6 Max 3 Stage, 3 Leg Rectangle C Foot	A6MREC3S3LCF	\$ 4378	\$ 4817	\$ 5473
	*3-Leg Max bases can accommodate worksurface configurations from 24"D x 48"W x 36"W to 30"D x 72"W x 72"W. *500 lb Max Lift Capacity				
	Foot Retrofit Options				
	Casters (Use on 2-leg bases ONLY)	A6CASTER*	\$ 277	N/A	N/A
	* A6 casters are intended for use with Allsteel A6 height-adjustable tables. When purchased separately and used without Allsteel furniture, the A6 casters marked by (*) are considered Open Market.				
	Slide Glides (Use on 2-leg bases ONLY)	A6SLDGLIDE	\$ 201	N/A	N/A
	G1 Glide (4-Pack)	A6G1GLIDE	\$ 217	N/A	N/A
*Glide enables 3-stage base to reach G1 requirement heights.					
Bluetooth Control					
A6 Bluetooth Accessory	A6BLUETOOTH	\$ 142	N/A	N/A	
* Bluetooth control will only work with 2-leg A6 tables. Bluetooth control will not work with 3-leg A6 tables.					

<p>How to specify — Select the Model Number from above.</p>	<p>1st Option: Select the Base Paint Color (if applicable): P1 P2 P3 See page 240 for paint finishes.</p>	<p>2nd Option: Select Feet Options (if applicable): X Standard Glides</p>	<p>3rd Option: Select the Keypad (if applicable): UD Basic Up/Down MEM Memory Preset PDL Paddle</p>
<p>Example: A6RND3S3LCF.P8L.X.PDL</p>			

For specification information see page 244.

GSA SIN PENDING

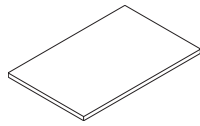

Description	Laminate w/Flat Edge Model	Ship Weight	List Price		
			L1	L2	L3
Undersized Rectangular Worksurface - 24"D (60" to 96" ships with stiffener)					
78"W - 96"W Tops can ONLY be used with Altitude MAX base.					
36"W	AF5RS3624U	23	\$ 511	\$ 536	\$ 560
42"W	AF5RS4224U	27	\$ 558	\$ 586	\$ 612
48"W	AF5RS4824U	31	\$ 626	\$ 657	\$ 686
54"W	AF5RS5424U	35	\$ 679	\$ 712	\$ 744
60"W	AF5RS6024UD	49	\$ 896	\$ 938	\$ 977
66"W	AF5RS6624UD	53	\$ 936	\$ 979	\$ 1020
72"W	AF5RS7224UD	57	\$ 966	\$ 1010	\$ 1052
78"W	AF5RS7824UD	62	\$ 1009	\$ 1054	\$ 1098
84"W	AF5RS8424UD	66	\$ 918	\$ 959	\$ 998
90"W	AF5RS9024UD	70	\$ 1066	\$ 1113	\$ 1159
96"W	AF5RS9624UD	74	\$ 1099	\$ 1147	\$ 1194

Undersized Rectangular Worksurface - 30"D (60" to 96" ships with stiffener)
78"W - 96"W Tops can ONLY be used with Altitude MAX base.

36"W	AF5RS3630U	29	\$ 568	\$ 596	\$ 623
42"W	AF5RS4230U	35	\$ 604	\$ 634	\$ 662
48"W	AF5RS4830U	40	\$ 704	\$ 738	\$ 771
54"W	AF5RS5430U	45	\$ 798	\$ 838	\$ 875
60"W	AF5RS6030UD	60	\$ 997	\$ 1043	\$ 1087
66"W	AF5RS6630UD	65	\$ 1062	\$ 1110	\$ 1157
72"W	AF5RS7230UD	70	\$ 1094	\$ 1143	\$ 1191
78"W	AF5RS7830UD	76	\$ 1137	\$ 1189	\$ 1238
84"W	AF5RS8430UD	81	\$ 1052	\$ 1099	\$ 1145
90"W	AF5RS9030UD	86	\$ 1205	\$ 1259	\$ 1312
96"W	AF5RS9630UD	91	\$ 1241	\$ 1296	\$ 1350

Note: Undersized worksurface dimensions are nominal. Actual widths and depths are undersized by 2".
 (Example: 24"D x 36"W = 22"D x 34"W)

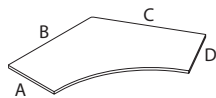

120 Degree Corner Worksurface - 24"D

24" A x 42" B x 42" C x 24" D	AF5120S4224D	59	\$ 1073	\$ 1122	\$ 1170
24" A x 48" B x 48" C x 24" D	AF5120S4824D	69	\$ 1185	\$ 1239	\$ 1292
24" A x 54" B x 54" C x 24" D	AF5120S5424D	79	\$ 1400	\$ 1464	\$ 1525

120 Degree Corner Worksurface - 30"D

30" A x 42" B x 42" C x 30" D	AF5120S4230D	68	\$ 1073	\$ 1122	\$ 1170
30" A x 48" B x 48" C x 30" D	AF5120S4830D	79	\$ 1508	\$ 1578	\$ 1644
30" A x 54" B x 54" C x 30" D	AF5120S5430D	92	\$ 1723	\$ 1802	\$ 1879

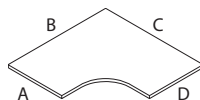

Symmetrical Corner Cove Worksurface — 24"D

24" A x 54" B x 54" C x 24" D	AF5CCS5424	56	\$ 1190	\$ 1247	\$ 1303
-------------------------------	------------	----	---------	---------	---------

Symmetrical Corner Cove Worksurface — 30"D

30" A x 54" B x 54" C x 30" D	AF5CCS5430	66	\$ 1300	\$ 1362	\$ 1423
-------------------------------	------------	----	---------	---------	---------

How to specify — Select the Model Number from above.	1st Option: FSC Certified Wood: FSC FSC Mixed Credit X Standard Wood	2nd Option: Laminate: See page 240 for finishes.	3rd Option: Laminate Edge Color: See page 240 for finishes.	4th Option: Grommet Location (if applicable): GC Grommet Center GO No Grommet	5th Option: Grommet Type (if applicable): P Oval Plastic M Oval Metal S Square Metal (Add \$13 per grommet for metal.)	6th Option: Grommet Color (Metal only): EL Matte Silver Plastic grommet color determined by worksurface finish.																																																																					
<table border="1"> <tr> <td><input type="checkbox"/></td><td><input type="checkbox"/></td><td><input type="checkbox"/></td><td><input type="checkbox"/></td><td><input type="checkbox"/></td><td><input type="checkbox"/></td><td><input type="checkbox"/></td><td><input type="checkbox"/></td><td><input type="checkbox"/></td><td><input type="checkbox"/></td> </tr> <tr> <td><input type="checkbox"/></td><td><input type="checkbox"/></td><td><input type="checkbox"/></td><td><input type="checkbox"/></td><td><input type="checkbox"/></td><td><input type="checkbox"/></td><td><input type="checkbox"/></td><td><input type="checkbox"/></td><td><input type="checkbox"/></td><td><input type="checkbox"/></td> </tr> </table>	<input type="checkbox"/>	<input type="checkbox"/>	<input type="checkbox"/>	<input type="checkbox"/>	<input type="checkbox"/>	<input type="checkbox"/>	<input type="checkbox"/>	<input type="checkbox"/>	<input type="checkbox"/>	<input type="checkbox"/>	<input type="checkbox"/>	<input type="checkbox"/>	<input type="checkbox"/>	<input type="checkbox"/>	<input type="checkbox"/>	<input type="checkbox"/>	<input type="checkbox"/>	<input type="checkbox"/>	<input type="checkbox"/>	<input type="checkbox"/>	<table border="1"> <tr> <td><input type="checkbox"/></td><td><input type="checkbox"/></td><td><input type="checkbox"/></td><td><input type="checkbox"/></td><td><input type="checkbox"/></td><td><input type="checkbox"/></td><td><input type="checkbox"/></td><td><input type="checkbox"/></td><td><input type="checkbox"/></td><td><input type="checkbox"/></td> </tr> </table>	<input type="checkbox"/>	<input type="checkbox"/>	<input type="checkbox"/>	<input type="checkbox"/>	<input type="checkbox"/>	<input type="checkbox"/>	<input type="checkbox"/>	<input type="checkbox"/>	<input type="checkbox"/>	<input type="checkbox"/>	<table border="1"> <tr> <td><input type="checkbox"/></td><td><input type="checkbox"/></td><td><input type="checkbox"/></td><td><input type="checkbox"/></td><td><input type="checkbox"/></td><td><input type="checkbox"/></td><td><input type="checkbox"/></td><td><input type="checkbox"/></td><td><input type="checkbox"/></td><td><input type="checkbox"/></td> </tr> </table>	<input type="checkbox"/>	<input type="checkbox"/>	<input type="checkbox"/>	<input type="checkbox"/>	<input type="checkbox"/>	<input type="checkbox"/>	<input type="checkbox"/>	<input type="checkbox"/>	<input type="checkbox"/>	<input type="checkbox"/>	<table border="1"> <tr> <td><input type="checkbox"/></td><td><input type="checkbox"/></td><td><input type="checkbox"/></td><td><input type="checkbox"/></td><td><input type="checkbox"/></td><td><input type="checkbox"/></td><td><input type="checkbox"/></td><td><input type="checkbox"/></td><td><input type="checkbox"/></td><td><input type="checkbox"/></td> </tr> </table>	<input type="checkbox"/>	<input type="checkbox"/>	<input type="checkbox"/>	<input type="checkbox"/>	<input type="checkbox"/>	<input type="checkbox"/>	<input type="checkbox"/>	<input type="checkbox"/>	<input type="checkbox"/>	<input type="checkbox"/>	<table border="1"> <tr> <td><input type="checkbox"/></td><td><input type="checkbox"/></td><td><input type="checkbox"/></td><td><input type="checkbox"/></td><td><input type="checkbox"/></td><td><input type="checkbox"/></td><td><input type="checkbox"/></td><td><input type="checkbox"/></td><td><input type="checkbox"/></td><td><input type="checkbox"/></td> </tr> </table>	<input type="checkbox"/>	<input type="checkbox"/>	<input type="checkbox"/>	<input type="checkbox"/>	<input type="checkbox"/>	<input type="checkbox"/>	<input type="checkbox"/>	<input type="checkbox"/>	<input type="checkbox"/>	<input type="checkbox"/>	<table border="1"> <tr> <td><input type="checkbox"/></td><td><input type="checkbox"/></td><td><input type="checkbox"/></td><td><input type="checkbox"/></td><td><input type="checkbox"/></td><td><input type="checkbox"/></td><td><input type="checkbox"/></td><td><input type="checkbox"/></td><td><input type="checkbox"/></td><td><input type="checkbox"/></td> </tr> </table>	<input type="checkbox"/>	<input type="checkbox"/>	<input type="checkbox"/>	<input type="checkbox"/>	<input type="checkbox"/>	<input type="checkbox"/>	<input type="checkbox"/>	<input type="checkbox"/>	<input type="checkbox"/>	<input type="checkbox"/>
<input type="checkbox"/>	<input type="checkbox"/>	<input type="checkbox"/>	<input type="checkbox"/>	<input type="checkbox"/>	<input type="checkbox"/>	<input type="checkbox"/>	<input type="checkbox"/>	<input type="checkbox"/>	<input type="checkbox"/>																																																																		
<input type="checkbox"/>	<input type="checkbox"/>	<input type="checkbox"/>	<input type="checkbox"/>	<input type="checkbox"/>	<input type="checkbox"/>	<input type="checkbox"/>	<input type="checkbox"/>	<input type="checkbox"/>	<input type="checkbox"/>																																																																		
<input type="checkbox"/>	<input type="checkbox"/>	<input type="checkbox"/>	<input type="checkbox"/>	<input type="checkbox"/>	<input type="checkbox"/>	<input type="checkbox"/>	<input type="checkbox"/>	<input type="checkbox"/>	<input type="checkbox"/>																																																																		
<input type="checkbox"/>	<input type="checkbox"/>	<input type="checkbox"/>	<input type="checkbox"/>	<input type="checkbox"/>	<input type="checkbox"/>	<input type="checkbox"/>	<input type="checkbox"/>	<input type="checkbox"/>	<input type="checkbox"/>																																																																		
<input type="checkbox"/>	<input type="checkbox"/>	<input type="checkbox"/>	<input type="checkbox"/>	<input type="checkbox"/>	<input type="checkbox"/>	<input type="checkbox"/>	<input type="checkbox"/>	<input type="checkbox"/>	<input type="checkbox"/>																																																																		
<input type="checkbox"/>	<input type="checkbox"/>	<input type="checkbox"/>	<input type="checkbox"/>	<input type="checkbox"/>	<input type="checkbox"/>	<input type="checkbox"/>	<input type="checkbox"/>	<input type="checkbox"/>	<input type="checkbox"/>																																																																		
<input type="checkbox"/>	<input type="checkbox"/>	<input type="checkbox"/>	<input type="checkbox"/>	<input type="checkbox"/>	<input type="checkbox"/>	<input type="checkbox"/>	<input type="checkbox"/>	<input type="checkbox"/>	<input type="checkbox"/>																																																																		

Example:

For specification information see page 244.

GSA SIN 33721

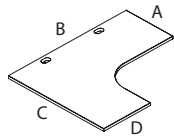

Description	Laminate w/Flat Edge Model	Ship Weight	List Price		
			L1	L2	L3
Corner Cove Laminate Tops — 24"D Extended Left					
24" A x 60" B x 36" C x 24" D	A5822ELS	54	\$ 1048	\$ 1084	\$ 1118
24" A x 60" B x 48" C x 24" D	A5622ELS	75	\$ 1148	\$ 1188	\$ 1225
24" A x 72" B x 36" C x 24" D	A5922ELS	63	\$ 1169	\$ 1209	\$ 1246
24" A x 72" B x 48" C x 24" D	A5722ELS	86	\$ 1462	\$ 1511	\$ 1557

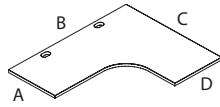

Corner Cove Laminate Tops — 24"D Extended Right					
24" A x 60" B x 36" C x 24" D	A5822ERS	54	\$ 1048	\$ 1084	\$ 1118
24" A x 60" B x 48" C x 24" D	A5622ERS	75	\$ 1148	\$ 1188	\$ 1225
24" A x 72" B x 36" C x 24" D	A5922ERS	63	\$ 1169	\$ 1209	\$ 1246
24" A x 72" B x 48" C x 24" D	A5722ERS	86	\$ 1462	\$ 1511	\$ 1557

Note: Height-adjustable worksurface dimensions are nominal. Actual widths are reduced by 2" (1" on each side" and worksurface depths are reduced by 3/4". Corner cove depth is nominal, actual is 1" less. This is to allow for pinch-points and unobstructed table movement.

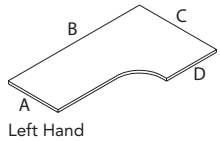

Undersized Corner Cove Worksurface, Left Hand — 24"D					
24" A x 60" B x 36" C x 24" D	AF5CCS603624LD	58	\$ 1098	\$ 1148	\$ 1197
24" A x 60" B x 48" C x 24" D	AF5CCS604824LD	67	\$ 1199	\$ 1254	\$ 1308
24" A x 72" B x 36" C x 24" D	AF5CCS723624LD	66	\$ 1236	\$ 1292	\$ 1347
24" A x 72" B x 48" C x 24" D	AF5CCS724824LD	75	\$ 1527	\$ 1597	\$ 1664

Left Hand

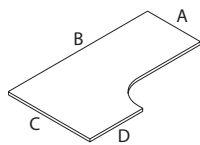

Undersized Corner Cove Worksurface, Right Hand — 24"D					
24" A x 60" B x 36" C x 24" D	AF5CCS603624RD	58	\$ 1098	\$ 1148	\$ 1197
24" A x 60" B x 48" C x 24" D	AF5CCS604824RD	67	\$ 1199	\$ 1254	\$ 1308
24" A x 72" B x 36" C x 24" D	AF5CCS723624RD	66	\$ 1236	\$ 1292	\$ 1347
24" A x 72" B x 48" C x 24" D	AF5CCS724824RD	75	\$ 1527	\$ 1597	\$ 1664

Right Hand

Undersized Corner Cove Worksurface, Left Hand — 30"D					
30" A x 60" B x 48" C x 30" D	AF5CCS604830LD	77	\$ 1282	\$ 1341	\$ 1399
30" A x 72" B x 48" C x 30" D	AF5CCS724830LD	88	\$ 1617	\$ 1691	\$ 1764

Undersized Corner Cove Worksurface, Right Hand — 30"D					
30" A x 60" B x 48" C x 30" D	AF5CCS604830RD	77	\$ 1282	\$ 1341	\$ 1399
30" A x 72" B x 48" C x 30" D	AF5CCS724830RD	88	\$ 1617	\$ 1691	\$ 1764

Note: Undersized worksurface dimensions are nominal. Actual widths and depths are reduced by 2".
(Example: 24" x 60" x 36" x 24" = 22" x 58" x 34" x 22")

<p>How to specify — Select the Model Number from above.</p>	<p>1st Option: Laminate or Veneer Type and Finish (if applicable): See page 240 for finishes.</p>	<p>2nd Option: Paint (if applicable): See page 240 for finishes.</p>	<p>3rd Option: Laminate Edge Color (if applicable): See page 240 for finishes.</p>	<p>4th Option: Grommet Location and Type:</p> <p>GC Center P Oval Plastic M Oval Metal</p> <p>GB Grommet LH/RH P Oval Plastic M Oval Metal S Square Metal</p> <p>GO No Grommet</p>
<p>Examples:</p>				

For specification information see page 247.

GSA SIN 33721

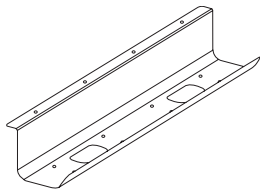

AJTRGH24

Description	Model	List Price		
		P1	P2	P3
Cable Management Trays				
24"W	AJTRGH24 S	\$ 123	N/A	N/A
36"W	AJTRGH36 S	\$ 147	N/A	N/A

- Available in 24" or 36" widths.
- Metal Cable Management Trays available in Black only, specify "P" for finish.
- Example: AJTRGH24.P

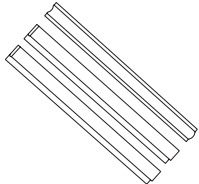

AWRSTRIP

Wire Management Strips/Channels				
	AWRSTRIP S	\$ 270	N/A	N/A

- Four wire management strips/channels in black only, no specification needed.
- Example: AWRSTRIP

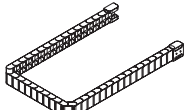

WKSWMC

Wire Management Chains				
36"	A9CLWMC S	\$ 357	N/A	N/A
58"	WKSWMC S	\$ 428	N/A	N/A

- Specify model A9CLWMC for 36" chain, specify model WKSWMC for 58" chain.
- A9CLWMC available in Black (E4), White (DW), or Silver (TI).
- WKSWMC available in Black only, no specification needed.
- Example: A9CLWMC.DW or WKSWMC

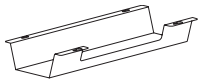

APWRTRGH17

Under Worksurface Troughs				
17"W	APWRTRGH17 S	\$ 108	N/A	N/A
36"W	APWRTRGH36 S	\$ 189	N/A	N/A

- Available in 17" or 36" widths.
- Under Worksurface Troughs available in Black only, no specification needed.
- Example: APWRTRGH17

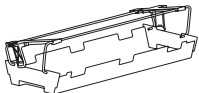

AFDTRGH20

Flip-Down Wire Management Trough				
20"W	AFDTRGH20 S	\$ 378	N/A	N/A
32"W	AFDTRGH32 S	\$ 429	N/A	N/A

- Available in 20" or 32" widths.
- Flip-Down Troughs available in Black only, specify "P" for Black.
- Example: AFTRGH20.P



AWIRECLT

Metal Wire Cleat				
	AWIRECLT S	\$ 129	\$ 142	\$ 148

- Available in standard metal paint finishes, see page 240 for options and specify desired finish.
- Example: AWIRECLT.PJW

<p>How to specify —</p> <p>Select the Model Number from above.</p>	<p>1st Option:</p> <p>Paint (if applicable): See page 240 for finishes.</p> <p>Plastics (if applicable):</p> <p>DW White TI Silver E4 Black</p>
---	---

Examples: AJTRGH24.P A9CLWMC.DW AWIRECLT.PR6

S Shippable by small-package carrier.

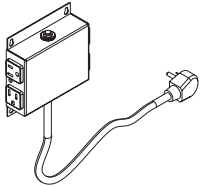

APWR4TAP

Description	Model	List Price
Power Module — Under Worksurface, Quad Tap		
7"W x 12"D x 3"H	APWR4TAP S	\$ 456

- 4 receptacles.
- 10' Straight cord only, no specification needed.
- Available in Black only, no specification needed.
- *Example: APWR4TAP*

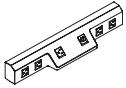

FDPWRC

Concealed Power Module		
Corded, 1 USB-A, 1 USB-C	FDPWRC S	\$ 766
Corded Chicago Code, 1 USB-A, 1 USB-C	CFDPWRC S	\$ 1306
Spiral Cord, 1 USB-A, 1 USB-C	FDPWRSC S	\$ 806
Spiral Cord Chicago Code, 1 USB-A, 1 USB-C	CFDPWRSC S	\$ 1338

- FDPWRC is plastic, straight cord unit with 4 receptacles, 1 USB-A and 1 USB-C port.
- CFDPWRC is metal, straight cord Chicago Code unit with 4 receptacles, 1 USB-A and 1 USB-C port.
- FDPWRSC is plastic, coiled cord unit with 4 receptacles, 1 USB-A and 1-USB-C port.
- CFDPWRSC is metal, coiled cord unit with 4 receptacles, 1 USB-A and 1 USB-C port.
- Available in Storm (STRM) only, specify Storm.
- *Example: FDPWRC.STRM*

ALTITUDE

<p>How to specify — Select the Model Number from above.</p>	<p><i>1st Option:</i> Paint (if applicable): STRM Storm</p>
<div style="display: flex; justify-content: space-between; width: 100%;"> <div style="display: flex; gap: 5px;"> <div style="border-bottom: 1px solid black; width: 20px; height: 15px;"></div> <div style="border-bottom: 1px solid black; width: 20px; height: 15px;"></div> <div style="border-bottom: 1px solid black; width: 20px; height: 15px;"></div> <div style="border-bottom: 1px solid black; width: 20px; height: 15px;"></div> <div style="border-bottom: 1px solid black; width: 20px; height: 15px;"></div> <div style="border-bottom: 1px solid black; width: 20px; height: 15px;"></div> <div style="border-bottom: 1px solid black; width: 20px; height: 15px;"></div> <div style="border-bottom: 1px solid black; width: 20px; height: 15px;"></div> <div style="border-bottom: 1px solid black; width: 20px; height: 15px;"></div> <div style="border-bottom: 1px solid black; width: 20px; height: 15px;"></div> <div style="border-bottom: 1px solid black; width: 20px; height: 15px;"></div> <div style="border-bottom: 1px solid black; width: 20px; height: 15px;"></div> <div style="border-bottom: 1px solid black; width: 20px; height: 15px;"></div> <div style="border-bottom: 1px solid black; width: 20px; height: 15px;"></div> <div style="border-bottom: 1px solid black; width: 20px; height: 15px;"></div> <div style="border-bottom: 1px solid black; width: 20px; height: 15px;"></div> <div style="border-bottom: 1px solid black; width: 20px; height: 15px;"></div> <div style="border-bottom: 1px solid black; width: 20px; height: 15px;"></div> <div style="border-bottom: 1px solid black; width: 20px; height: 15px;"></div> <div style="border-bottom: 1px solid black; width: 20px; height: 15px;"></div> <div style="border-bottom: 1px solid black; width: 20px; height: 15px;"></div> </div> </div> <div style="display: flex; gap: 5px;"> <div style="border-bottom: 1px solid black; width: 20px; height: 15px;"></div> <div style="border-bottom: 1px solid black; width: 20px; height: 15px;"></div> <div style="border-bottom: 1px solid black; width: 20px; height: 15px;"></div> <div style="border-bottom: 1px solid black; width: 20px; height: 15px;"></div> <div style="border-bottom: 1px solid black; width: 20px; height: 15px;"></div> </div>	<div style="display: flex; justify-content: space-between; width: 100%;"> <div style="display: flex; gap: 5px;"> <div style="border-bottom: 1px solid black; width: 20px; height: 15px;"></div> <div style="border-bottom: 1px solid black; width: 20px; height: 15px;"></div> <div style="border-bottom: 1px solid black; width: 20px; height: 15px;"></div> <div style="border-bottom: 1px solid black; width: 20px; height: 15px;"></div> <div style="border-bottom: 1px solid black; width: 20px; height: 15px;"></div> </div> </div> <div style="display: flex; gap: 5px;"> <div style="border-bottom: 1px solid black; width: 20px; height: 15px;"></div> <div style="border-bottom: 1px solid black; width: 20px; height: 15px;"></div> <div style="border-bottom: 1px solid black; width: 20px; height: 15px;"></div> <div style="border-bottom: 1px solid black; width: 20px; height: 15px;"></div> </div>

Examples: APWR4TAP FDPWRC.STRM

S *Shippable by small-package carrier.*

For specification information see page 247.1.

GSA SIN 33721

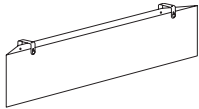

APWRMODEST36

Description	Model	List Price	
		A	B
Fabric Power Modesty			
	APWRMODEST36 S	\$ 1162	\$ 1196
	APWRMODEST48 S	\$ 1258	\$ 1297

- Available in Appoint, Binary, Centurion, Noble, Reflections, Disperse, and Spin panel fabric series.
- Specify desired fabric.
- Example: APWRMODEST36.NBLE16

<p>How to specify — Select the Model Number from above.</p> <p>_____ .</p>	<p><i>1st Option:</i> Fabric (if applicable): See page 10 for fabrics.</p> <p>_____</p>
---	--

Example: APWRMODEST36.NBLE16

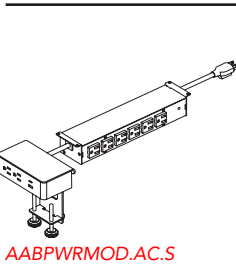

AABPWRMOD.AC.S

Description	Model	List Price
Power Module — Above/Below Worksurface 8¼"W x 16"D x 4½"H	AABPWRMOD S	\$ 1234

- Desktop unit includes 2 receptacles, 1 USB-A, & 1 USB-C (AC).
- Under worksurface unit include 6 receptacles.
- Power cord choices include a 6' Straight cord (S) or Coiled cord (Q).
- Desktop unit available in White (DWT) or Gray (DGY).
- Example: AABPWRMOD.AC.S.DWT

<p>How to specify — Select the Model Number from above.</p> <p>A A B P W R M O D .</p>	<p><i>1st Option:</i> Ports (Final port option if applicable): AC USB-A+C</p> <p>A C .</p>	<p><i>2nd Option:</i> Cord Type (Power Module cord type if applicable): S Straight Cord Q Coiled Cord</p> <p>_____ .</p>	<p><i>3rd Option:</i> Color Option (if applicable): DWT White DGY Gray</p> <p>_____ .</p>
---	---	---	--

Example: AABPWRMOD.AC.Q.DWT

S Shippable by small-package carrier.

ALTITUDE

For specification information see page 247.2.

GSA SIN 33721

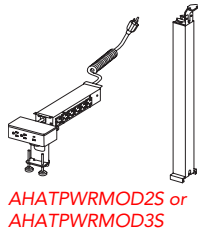

Description	Model	List Price		
		P1	P2	P3
Metal Telescoping HAT Wire Management				
	AHATPWRMOD2S	\$ 1614	\$ 1654	\$ 1675
	AHATPWRMOD3S	\$ 1646	\$ 1690	\$ 1711

- AHATPWRMOD2S pairs with 2-stage HAT bases.
- AHATPWRMOD3S pairs with 3-stage HAT bases.
- Desktop power module comes with 2 receptacles, 1 USB-A, and 1 USB-C port only, specify “AC” for this power configuration.
- Desktop power module available in White (DWT) or Gray (DGY) finishes, specify desired finish.
- Under worksurface power strip comes with 6 receptacles and is available in Black only, no specification needed.
- Metal Telescoping Chase available in the same paint finishes as Altitude HAT bases, specify desired paint finish.
- *Example: AHATPWRMOD2S.AC.DWT.PJW*

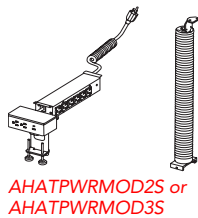

Description	Model	List Price		
		P1	P2	P3
Fabric HAT Wire Management				
	AHATPWRMODF	\$ 1476	\$ 1503	\$ 1516

- AHATPWRMODF pairs with 2-stage and 3-stage HAT bases.
- Desktop power module comes with 2 receptacles, 1 USB-A, and 1 USB-C port only, specify “AC” for this power configuration.
- Desktop power module available in White (DWT) or Gray (DGY) finishes, specify desired finish.
- Under worksurface power strip comes with 6 receptacles and is available in Black only, no specification needed.
- Fabric HAT Chase available in three fabric finishes of Light (LGT), Medium (MDD), and Dark (DRK), specify desired fabric finish.
- Fabric HAT mounting brackets available in the same paint finishes as Altitude HAT bases, specify desired paint finish.
- *Example: AHATPWRMODF.AC.DGY.LGT.PR5*

ALTITUDE

<p>How to specify — Select the Model Number from above.</p>	<p><i>1st Option:</i> Ports (Final port option if applicable): AC USB-A+C</p>	<p><i>2nd Option:</i> Power Module Color Option (if applicable): DWT White DGY Gray</p>	<p><i>3rd Option:</i> Fabric Chase Finish (if applicable): LGT Light MDD Medium DRK Dark</p>	<p><i>4th Option:</i> Metal Paint Option (if applicable): See page 240 for finishes.</p>
<p>AHATPWRMOD . AC . D . . </p>				

*Example: AHATPWRMOD3S.AC.DWT.P8C
AHATPWRMODF.AC.DGY.LGT.PR5*

S Shippable by small-package carrier.

For specification information see page 260.

GSA SIN 33721

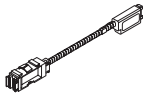
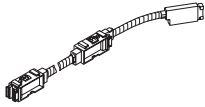

Description	Max. Recept. Cap. per Panel Side	Four-circuit 3 + 1 2 + 2	Three-circuit Separate Neutrals		List Price
Electrical Power Harnesses					
For 48" W Frames	2	A871248*	A871248A	<input type="checkbox"/>	\$ 416
For 54" W Frames	2	A871254*	A871254A	<input type="checkbox"/>	\$ 414
For 60" W Frames	2	A871260*	A871260A	<input type="checkbox"/>	\$ 416
For 66" W Frames	2	A871266*	A871266A	<input type="checkbox"/>	\$ 414
For 72" W Frames	2	A871272*	A871272A	<input type="checkbox"/>	\$ 417

Note: Four-circuit components and Three-circuit components (with an "A" suffix) cannot be connected together.

Electrical Pass-Thru Harnesses with Power Block

For 24" W Frames**	1	A871124	A871124A	<input type="checkbox"/>	\$ 239
For 48" W Frames†	1	A871148*	A871148A	<input type="checkbox"/>	\$ 255
For 60" W Frames†	1	A871160*	A871160A	<input type="checkbox"/>	\$ 255
For 72" W Frames†	1	A871172	A871172A	<input type="checkbox"/>	\$ 341

Electrical harnesses are intended for use with Allsteel systems furniture and are approved under GSA SIN 33721. When purchased separately and used without Allsteel systems furniture, those electrical harnesses marked by () are considered Open Market.

**Only used with NY Infeed through End Cap.

†48"-72" are only used with NY infeed through power rail cut-out.

<p>How to specify — Select the Model Number from above.</p> <p>_____ .</p>	<p><i>1st Option:</i> Color: P Black</p>
---	---

Examples: A871248.P A871224.P A871224A.P A871124.P
A8710144A.P A2-8CIR36.P

Shippable by small-package carrier.

For specification information see page 260.

GSA SIN 33721

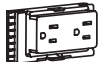

Duplex Receptacle

Description	Four-circuit 3 + 1 2 + 2	Three-circuit Separate Neutrals		List Price
Duplex Receptacles for Beltline or Base Pathway — Altitude (specify color)				
Circuit 1	A873501	A871501A	S	\$ 72
Circuit 2	A873502	A871502A	S	\$ 72
Circuit 3 (3+1)	A873503	A871503A	S	\$ 72
Circuit 3 (2+2)	A873506	N/A	S	\$ 72
Circuit 4 — iso/dedicated	A873504	N/A	S	\$ 72
Circuit 1, 20 AMP	A871601	A871601A	S	\$ 72

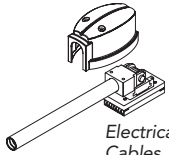

Electrical Infeed Cables

Electrical Infeed Cables				
6' Sealtight Cable for Terrace Receptacle	A876072	A8716072A	S	\$ 439
6' Flex Cable	A871972	A871972A	S	\$ 331

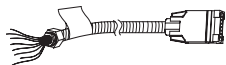

Ceiling Electrical Infeed

Ceiling Electrical Infeed Cables				
12' Flex Cable	A871912	A871912A	S	\$ 449
18' Flex Cable	A871918	A871918A	S	\$ 565

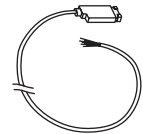

Electrical Infeed Cable

Electrical Infeed Cables (for use with footed panels)				
12' Sealtight Cable Power Infeed	A877012	N/A	S	\$ 547

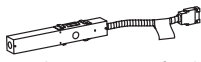

Hardwire Power Infeed

Hardwire Power Infeed (New York Code)				
For 48"-72" W rails	A871400	A871400A	S	\$ 431

Note: Four-circuit components and Three-circuit components (with an "A" suffix) cannot be connected together.

<p>How to specify — Select the Model Number from above.</p> <p>_____ .</p>	<p><i>1st Option:</i> Electrical Receptacle Color (if applicable): See page 240 for finishes.</p> <p>E S</p>
---	---

Example: A873501.E4

For specification information see page 260.

GSA SIN 33721



Description	Model	List Price
Hardwire (Chicago Code) (Black only)		
Altitude Base Pathway Junction Box (Pack of 6)	873600	\$ 1145

For specification information see page 261.

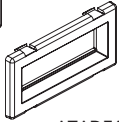
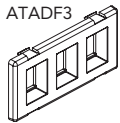

ATADF4

Description	Model	P1 Paint List Price
Data Faceplates		
Three-Port Flex-Mode Faceplate, Black (E4)	ATADF3	\$ 42
Four-Port Flex-Mode Faceplate, Black (E4)	ATADF4	\$ 42

Notes: ATADF3 can install up to 3 jacks (CAT 3, 5E, or 6). ATADF4 can install 4 jacks (CAT 3, 5E, or 6).

ATADF models are compatible with ports in Altitude tiles.

Allsteel's data faceplates are designed for use with the jacks listed below. We do not guarantee compatibility with other manufacturers' product. A faceplate adapter is available for use with alternatively sourced data jacks, see the Standard Specials catalog for details.

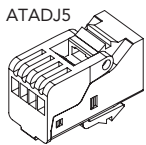

Jacks		
RJ45 CAT 5E Jack — Black only		
Toolless	ATADJ5	\$ 74
RJ45 CAT 6 Jack — Black only		
Requires Tool	ATADJ6	\$ 98

How to specify —

Select the Model Number from above.



Example: 873600

How to specify —

Select the Model Number from above.

1st Option:

Data Faceplate Color:

E4 Black



Example: ATADF4.E4

Shippable by small-package carrier.

For specification information see page 248.
(See page 307 for COM pricing on fabric grades G-J.)

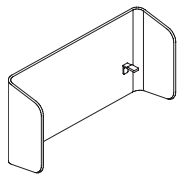

Description	Model	Ship Weight	Cubes	List Price	
				A	D
U Screen Kit					
48"	FDSC48U	30.0	16.6	\$ 2032	\$ 2157
54"	FDSC54U	31.0	18.6	\$ 2102	\$ 2232
60"	FDSC60U (shown)	32.0	20.6	\$ 2163	\$ 2297
66"	FDSC66U	33.0	22.6	\$ 2290	\$ 2434
72"	FDSC72U	34.0	24.6	\$ 2463	\$ 2618

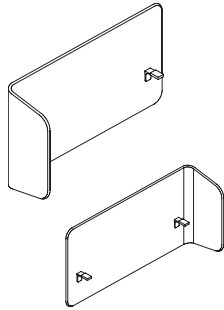

L Screen Kit					
Left Hand 48"	FDSC48LL	26.5	16.6	\$ 1322	\$ 1395
Right Hand 48"	FDSC48LR	26.5	16.6	\$ 1322	\$ 1395
Left Hand 54"	FDSC54LL	27.5	18.6	\$ 1549	\$ 1636
Right Hand 54"	FDSC54LR	27.5	18.6	\$ 1549	\$ 1636
Left Hand 60"	FDSC60LL (shown)	28.5	20.6	\$ 1619	\$ 1712
Right Hand 60"	FDSC60LR (shown)	28.5	20.6	\$ 1619	\$ 1712
Left Hand 66"	FDSC66LL	29.5	22.6	\$ 1928	\$ 2047
Right Hand 66"	FDSC66LR	29.5	22.6	\$ 1928	\$ 2047
Left Hand 72"	FDSC72LL	30.5	24.6	\$ 2030	\$ 2155
Right Hand 72"	FDSC72LR	30.5	24.6	\$ 2030	\$ 2155

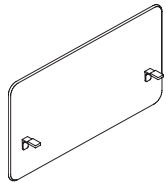

Rectangular Screen Kit					
48"	FDSC48R	23.0	3.7	\$ 1279	\$ 1350
54"	FDSC54R	24.0	4.1	\$ 1310	\$ 1383
60"	FDSC60R (shown)	25.0	4.6	\$ 1407	\$ 1486
66"	FDSC66R	26.0	5.0	\$ 1617	\$ 1714
72"	FDSC72R	27.0	5.6	\$ 1721	\$ 1826

Note: Installation brackets are now attached to the screen from the factory.

<p>How to specify — Select the Model Number from above.</p>	<p>1st Option: Select the Screen Fabric: See page 241 for selections and color codes.</p>	<p>2nd Option: Select the Screen Bracket Paint: P1 P2 See page 240 for selections and color codes.* P2 (\$16 extra)</p>
<p>_____ .</p>	<p>_____ .</p>	<p>_____</p>

Examples: FDSC48U.PCAMBLT40.P71 FDSC48LL.PCAMBLT70.P71 FDSC48R.PCAMBLT39.P71

For specification information see pages 249-250.

GSA SIN 33721

		Description	Model	P1 Paint List Price	P2 Paint Upcharge	P3 Paint Upcharge
		20"H Metal L-Screen				
		48"W	AMS2048LH	\$ 833	\$ 866	\$ 899
		54"W	AMS2054LH	\$ 906	\$ 942	\$ 978
		60"W	AMS2060LH	\$ 1014	\$ 1055	\$ 1094
		66"W	AMS2066LH	\$ 1109	\$ 1153	\$ 1196
		72"W	AMS2072LH	\$ 1160	\$ 1206	\$ 1251
		48"W	AMS2048RH (shown)	\$ 833	\$ 866	\$ 899
		54"W	AMS2054RH	\$ 906	\$ 942	\$ 978
		60"W	AMS2060RH	\$ 1014	\$ 1055	\$ 1094
		66"W	AMS2066RH	\$ 1109	\$ 1153	\$ 1196
		72"W	AMS2072RH	\$ 1160	\$ 1206	\$ 1251
		30"H Metal L-Screen				
		48"W	AMS3248LH	\$ 1081	\$ 1124	\$ 1166
		54"W	AMS3254LH	\$ 1145	\$ 1191	\$ 1235
		60"W	AMS3260LH	\$ 1196	\$ 1243	\$ 1290
		66"W	AMS3266LH	\$ 1312	\$ 1364	\$ 1415
		72"W	AMS3272LH	\$ 1363	\$ 1417	\$ 1470
		48"W	AMS3248RH (shown)	\$ 1081	\$ 1124	\$ 1166
		54"W	AMS3254RH	\$ 1145	\$ 1191	\$ 1235
		60"W	AMS3260RH	\$ 1196	\$ 1243	\$ 1290
		66"W	AMS3266RH	\$ 1312	\$ 1364	\$ 1415
		72"W	AMS3272RH	\$ 1363	\$ 1417	\$ 1470
		20"H Metal U-Screen				
		48"W	AMS2048US (shown)	\$ 1086	\$ 1130	\$ 1171
		54"W	AMS2054US	\$ 1145	\$ 1191	\$ 1235
		60"W	AMS2060US	\$ 1196	\$ 1243	\$ 1290
		66"W	AMS2066US	\$ 1312	\$ 1364	\$ 1415
		72"W	AMS2072US	\$ 1377	\$ 1432	\$ 1485
		48"W	AMS3248US (shown)	\$ 1304	\$ 1356	\$ 1406
		54"W	AMS3254US	\$ 1374	\$ 1428	\$ 1482
		60"W	AMS3260US	\$ 1435	\$ 1492	\$ 1547
		66"W	AMS3266US	\$ 1574	\$ 1635	\$ 1697
		72"W	AMS3272US	\$ 1653	\$ 1718	\$ 1782

<p>How to specify — Select the Model Number from above.</p>	<p>1st Option: Wing Type :</p> <p>STD Standard EXT Extended</p>	<p>2nd Option: Accessories Slots:</p> <p>X No Accessory Cut Out SLT Accessory Cut Out</p>	<p>3rd Option: Paint Option:</p> <p>P1 P2 P3 See page 240 for finishes.</p>	<p>4th Option: Paint Option:</p> <p>NA Screen</p>
	<p>_____ . _____ . _____ . P _____ . NA</p>			

Examples: AMS2048LH.STD.SLT.PR6.NA AMS2048SS.PR6.NA



Shippable by small-package carrier.

For specification information see pages 249-250.

GSA SIN 33721

Description	Model	P1 Paint List Price	P2 Paint Upcharge	P3 Paint Upcharge
20"H Metal Rectangular Screen				
48"W	AMS2048SS (shown)	\$ 710	\$ 739	\$ 766
54"W	AMS2054SS	\$ 746	\$ 776	\$ 805
60"W	AMS2060SS	\$ 796	\$ 828	\$ 858
66"W	AMS2066SS	\$ 906	\$ 942	\$ 978
72"W	AMS2072SS	\$ 978	\$ 1018	\$ 1056
30"H Metal Rectangular Screen				
48"W	AMS3248SS (shown)	\$ 870	\$ 904	\$ 938
54"W	AMS3254SS	\$ 906	\$ 942	\$ 978
60"W	AMS3260SS	\$ 964	\$ 1002	\$ 1041
66"W	AMS3266SS	\$ 1086	\$ 1130	\$ 1171
72"W	AMS3272SS	\$ 1145	\$ 1191	\$ 1235
15"H Tackboard Accessories				
20"W	AAS1520 S	\$ 309	\$ 322	\$ 333
48"W	AAS1548 S (shown)	\$ 367	\$ 383	\$ 396
54"W	AAS1554 S	\$ 406	\$ 423	\$ 438
60"W	AAS1560 S	\$ 423	\$ 441	\$ 456
66"W	AAS1566 S	\$ 617	\$ 641	\$ 666
72"W	AAS1572 S	\$ 675	\$ 702	\$ 729

<p>How to specify — Select the Model Number from above.</p>	<p>1st Option: Wing Type : STD Standard EXT Extended</p>	<p>2nd Option: Accessories Slots: X No Accessory Cut Out SLT Accessory Cut Out</p>	<p>3rd Option: Paint Option: P1 P2 P3 See page 240 for finishes.</p>	<p>4th Option: Paint Option: NA Screen</p>	<p>5th Option: Accessories Color (if applicable): DW Designer White E9 Flint</p>
<p>Examples: AAS1548.PR6.APN911 AFAMS2048LH.STD.SLT.PR6.NA AFAMS2048SS.PR6.NA</p>					

Work Tools	Description	Model	List Price
	Hot File (Designer White Only) 9½"H x 12¼"W x 3¾"D	AEHF	\$ 64
	Side Saddle (Designer White Only) 4"H x 12¼"W x 2½"D	AESS	\$ 53
	Bag or Coat Hook (Designer White Only) 3¼"H x 1½"W x 2¼"D	AECH	\$ 41

<p>How to specify — Select the Model Number from above.</p>	<p>1st Option: Paint Option (if applicable): P1 P2 P3 See page 240 for finishes.</p>	<p>2nd Option: Fabric Option (if applicable): See page 241 for fabric options.</p>	<p>3rd Option: Paint Option: NA Screen</p>	<p>4th Option: Accessories Color (if applicable): DW Designer White E9 Flint</p>
<p>Example: AEHF.PJW</p>				

S Shippable by small-package carrier.

For specification information see pages 251-256.

GSA SIN 33721

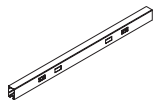

Description	Model	Ship Weight	Cubes	List Price		
				P1	P2	P3
Power Rail						
48"	RFDRW48	7	0.6	\$ 632	\$ 680	\$ 750
54"	RFDRW54	8	0.6	\$ 667	\$ 717	\$ 790
60"	RFDRW60 (shown)	9	0.7	\$ 768	\$ 824	\$ 909
66"	RFDRW66	10	0.8	\$ 819	\$ 879	\$ 967
72"	RFDRW72	11	0.9	\$ 924	\$ 991	\$ 1090

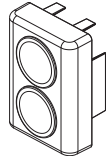

Power Rail End Cap	FDRWEC	1.5	0.1	\$ 235	\$ 253	\$ 278
--------------------	--------	-----	-----	--------	--------	--------

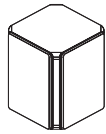

Power Rail Universal Connector	FDRWUC	3	0.1	\$ 428	\$ 458	\$ 503
--------------------------------	--------	---	-----	--------	--------	--------

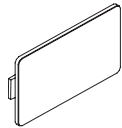

Electrical Port Cover						
2 Pack	FDEPC2	1	0.1	\$ 64	\$ 70	\$ 76
12 Pack	FDEPC12	2	0.1	\$ 220	\$ 237	\$ 260

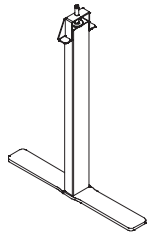

Elevated Power Rail Legs 20.5"H	RFDRWLEG	5	0.1	\$ 385	\$ 388	\$ 388
---------------------------------	----------	---	-----	--------	--------	--------

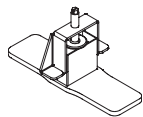

Floor Mount Legs	FDRWLEG	5	0.1	\$ 84	\$ 87	\$ 89
------------------	---------	---	-----	-------	-------	-------

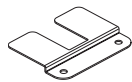

Altitude Power Rail Floor Anchor Bracket	RFDRWAB	2	0.1	\$ 55	\$ 73	\$ 80
--	---------	---	-----	-------	-------	-------

<p>How to specify — Select the Model Number from above.</p> <p>_____ .</p>	<p><i>1st Option:</i> Paint: P1 P2 P3 See page 240 for selections and color codes.*</p> <p>_____</p>
---	---

Examples:

For specification information see pages 251-256.

GSA SIN 33721

Description	Model	Ship Weight	Cubes	List Price		
				P1	P2	P3
Hubs						
End of Run Linear Configuration	RFDRWHUBEND	10	4	\$ 1097	\$ 1104	\$ 1110
End of Run T-Configuration	RFDRWHUBENDT	10	4	\$ 1097	\$ 1104	\$ 1110
Inline Linear Configuration	RFDRWHUBLIN	14	4	\$ 1097	\$ 1104	\$ 1110
Inline X-Configuration	RFDRWHUBX	14	4	\$ 1097	\$ 1104	\$ 1110
Inline T-Configuration	RFDRWHUBT	13	4	\$ 1097	\$ 1104	\$ 1110
L-Configuration Hub	RFDRWHUBL	13	4	\$ 1097	\$ 1104	\$ 1110

<p>How to specify — Select the Model Number from above.</p>	<p>1st Option: Paint: P1 P2 P3 See page 240 for selections and color codes.*</p>
--	--

Examples:



For specification information see pages 251-256.

GSA SIN 33721

Description	Model	Ship Weight	Cubes	List Price		
				P1	P2	P3
Power Pole						
8' H Square Power Pole	UN2HPSQ	17	1	\$ 1138	\$ 1156	\$ 1169
Square Power Pole Splicer Kit	UN2HPSQSK	0.5	0.1	\$ 125	\$ 129	\$ 130
Power Pole Connector	RFDRWCNPP	1	0.1	\$ 236	\$ 239	\$ 241
Power Pole Connector - End Condition	RFDRWCNPPE	1	0.1	\$ 236	\$ 239	\$ 241
Power Pole Connector - Mid Condition	RFDRWCNPPM	1	0.1	\$ 236	\$ 239	\$ 241

UN2HPSQ



UN2HPSQSK

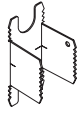

RFDRWCNPP

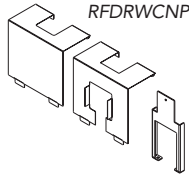

RFDRWCNPPE

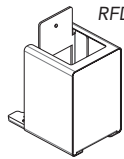

RFDRWCNPPM

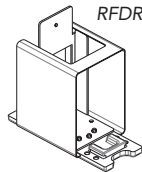

Wire Management

Vertebrae Wire Manager	RFDRWWM	3	0.1	\$ 721	\$ 739	\$ 746
------------------------	---------	---	-----	--------	--------	--------

*Includes connector for Power Rail attachment

*Vertebrae available in black only, connector available in 32 standard paints.



How to specify —

Select the Model Number from above.



Examples:

1st Option:

Paint:



See page 240 for selections and color codes.*



For specification information see pages 251-256.

GSA SIN 33721

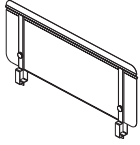

Description	Model	Ship Weight	Cubes	List Price		
				P1	P2	P3
Allsteel Metal Screen						
48"	RFDRWSC48	10	3.52	\$ 394	\$ 404	\$ 416
54"	RFDRWSC54	11	3.84	\$ 418	\$ 428	\$ 440
60"	RFDRWSC60	12	4.21	\$ 433	\$ 445	\$ 458
66"	RFDRWSC66	13	4.58	\$ 441	\$ 453	\$ 466
72"	RFDRWSC72	14	4.96	\$ 473	\$ 485	\$ 498

ALTITUDE

<p>How to specify — Select the Model Number from above.</p> <p>_____ .</p>	<p>1st Option: Paint: P1 P2 P3 See page 240 for selections and color codes.*</p> <p>_____</p>
---	---

Examples:

HAT to Panel Brackets

HAT to Panel Bracket Pricing

GSA SIN 33721

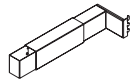

ABKTR

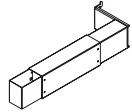

ABKTL

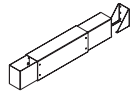

ABKCR

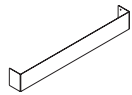

ABKCL

Description	Model	List Price
HAT to Panel Bracket T-leg RH	ABKTR	\$ 258
HAT to Panel Bracket T-leg LH	ABKTL	\$ 258
HAT to Panel Bracket C-leg RH	ABKCR	\$ 258
HAT to Panel Bracket C-leg LH	ABKCL	\$ 258
HAT to Gallery Panel Bracket T-leg	AGBKT	\$ 258
HAT to Gallery Panel Bracket C-leg	AGBKC	\$ 258
HAT to Gallery Panel Install Template <i>(Black only, code P)</i>	AGBKTMP	\$ 63

ALTITUDE

















<p>How to specify — Select the Model Number from above.</p>	<p><i>1st Option:</i> Paint (if applicable):</p>
<p>A . </p>	

Accessories

Worksurface Mounted Rail and Accessories

For specification information see page 265.

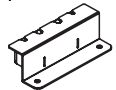
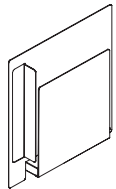
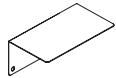
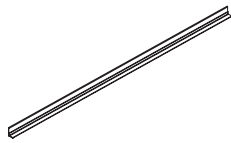

GSA SIN 33721

Description	Model	List Price		
		P1	P2	P3
Accessories Rail — Worksurface Mounted				
12"W	U912WTR 	\$ 120	\$ 128	\$ 132
18"W	U918WTR 	\$ 128	\$ 136	\$ 140
24"W	U924WTR 	\$ 147	\$ 155	\$ 159
30"W	U930WTR 	\$ 164	\$ 175	\$ 182
36"W	U936WTR 	\$ 186	\$ 197	\$ 204
42"W	U942WTR 	\$ 201	\$ 212	\$ 219
48"W	U948WTR 	\$ 212	\$ 227	\$ 232
54"W	U954WTR 	\$ 221	\$ 237	\$ 241
60"W	U960WTR 	\$ 232	\$ 249	\$ 255
66"W	U966WTR 	\$ 279	\$ 296	\$ 302
Rail Mounted Accessories				
Phone/Tablet Stand — 6½"H x 4¼"W	U9TM 	\$ 181	\$ 194	\$ 204
Pencil Holder — 2½"H x 6"W x 3"D	U9TP 	\$ 110	\$ 121	\$ 128
Shelf — 8"W x 4½"D; 2½" above top of worksurface	U9TS 	\$ 132	\$ 145	\$ 155
Vertical Paper Tray — 12"H x 1⅝"W x 12"D	U9TF 	\$ 198	\$ 211	\$ 221
Cord Organizer				
4"W x ⅞"D Metal with 4 cable cutouts	U9WTC 	\$ 196	\$ 205	\$ 212
Universal Hook (Black only)				
Package of 2	AGSAUHK 	\$ 132	—	—



How to specify —
Select the Model Number from above.

U | 9 | | | | | | | .

1st Option:
Paint:
  
See page 240 for selections and color codes.*

Examples: U912WTR.PR6 U9TF.P7G AGSAUHK.P27

 Shippable by small-package carrier.

Extensions — Introduction

Extensions accessory line by Allsteel is designed to help you create your own space.

- **Create a personalized space**

Each person works differently, different work styles require different tools. As our workplace needs shift from paper filing to personal storage, the tools that support us day-to-day need to adapt to the changing ways we are expected to work. Whether it's the need for paper filing, a place to plug a charger in, or a small shelf for trinkets, Extensions help you bear it all.

- **Create a comfortable space**

Encourage wellness and peace of mind while you work with Extensions. Whether by clearing valuable desk space, routing cords out of the way, powering your technology, or illuminating tasks with a gentle glow, this full line of work tools help you stay calm and in control of your workspace.

- **Create an empowered space**

Without all the right tools you need to succeed, having a productive workday can feel like an impossible task. With a full line of ergonomic, organization, illumination, power, and wire management tools, Extensions put the right tools within reach, allowing you to get your work done seamlessly and efficiently.

- **Organization tools**

Embracing organization work tools can help add efficiency and excitement to your daily workflow. Durably made but thoughtfully designed to help you organize and store the tools you need throughout your day, Extensions organizational tools help you find that perfect place for anything.

- **Ergonomic tools**

Ergonomics is more than just comfort, it's flexibility and safety. The adjustable keyboard options allow users to maintain and vary comfortable wrist and arm positions throughout the day, whether typing or mousing. Monitor Arms offer versatile adjustability while providing optimum comfort for the eyes, neck, and shoulders.

- **Illumination tools**

Sleek and flexible, our lighting components offer you several choices. Recessed task lights conserve space and feature electronic ballast for longer bulb life and cooler operating temperature. LED tasklights' slim design blends in with its surrounding while utilizing energy-efficient LED technology.

- **Power/Data tools**

At the heart of every workspace is a power module that keeps you plugged-in and running throughout the day. These indispensable accessories provide wired or wireless connectivity anywhere and everywhere you could possibly need it, transforming your workplace into a hub of activity.

- **Wire Management tools**

Eliminate the cord clutter under your desk with our extensive wire management offering. Allsteel wire management accessories effortlessly weave wires out of the way and clear your workspace with ease. Both free-standing and height adjustable, table-integrated solutions ensure that your space stays as clear as your workflow.

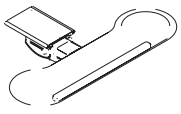
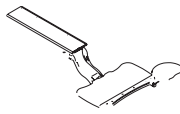
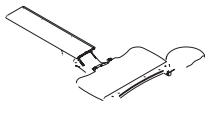
Articulating Keyboard Supports			
Features	Model AKTSHORT	Model AKTLONG	Model AKTMID
			
Keyboard Support	Platform style 28"W x 8"D	Platform Style 19"Wx11"D	Platform Style 19"Wx11"D
Keyboard Support Material	Phenolic	Phenolic	Phenolic
Suspension	<ul style="list-style-type: none"> Nylon glides on lubricated slide track Intuitive lift and lock one touch height adjustment 	Lubricated slide track system: spring assisted	Lubricated slide track system: spring assisted
Platform Rotation	360 degrees	360 degrees	360 degrees
Platform Tilt	+10/-20 degrees	+10/-20 degrees	+10/-20 degrees
Platform Tilt Adjustment	Soft touch lever for precise tilt adjustment	Convenient tilt wheel assists desired tilt angle	Convenient tilt wheel assists desired tilt angle
Platform Height Adjustment Range	6 1/2" (1 1/2" above / 5 1/4" below)	12 1/2" (7" above to 5 1/2" below)	8" (3" above / 5" below)
Platform Height Adjustment	Lift platform to raise, lift slightly and tilt back to lower	Lift platform to raise, lift slightly and tilt back to lower	Lift platform to raise, lift slightly and tilt back to lower
Palm Rest	Detachable leatherette-covered gel palm rest	Fabric covered gel palm rest	Fabric covered gel palm rest
Mouse Pad	In-line to accommodate mouse on same level as keyboard.	Circular, swivel, tilt, LH/RH mounting, mouse catcher, gel rest	Circular, swivel, tilt, LH/RH mounting, mouse catcher, gel rest
Microsoft Natural Compatible	No	Yes — by removing palm rest	Yes — by removing palm rest
Track Depth	8"	23"	21"
Required Mounting Clearance	20"W x 8"D x 1/4" Recess	19"W x 23"D + 1/4" Recess	19"W x 23"D + 1/4" Recess
Adjustable Wrist Rest	No	Fixed mounting and height	Fixed mounting and height
Ideal For	<ul style="list-style-type: none"> Straight worksurfaces ADA/HFES compliance Extensive adjustability with mouse in line, mouse over or mouse forward of keyboard Height-Adjustable Table 	<ul style="list-style-type: none"> Corner worksurface applications Sit to stand applications 	<ul style="list-style-type: none"> Shallow worksurfaces Corner worksurface (17" or 21") Radius worksurface (42" or 48")
Additional Information		<ul style="list-style-type: none"> Track can be cut in the field to shorten track depth — may affect ability to fully recess platform 	<ul style="list-style-type: none"> Track can be cut in the field to shorten track depth — may affect ability to fully recess platform

AKTSHORT Keyboard Support (page 286)

- Lift and lock intuitive height adjustment.
- Compatible with Altitude Height Adjustable Tables
- Positive and negative tilt for best ergonomic positioning.
- +10°/-20° tilt adjustment and 360° rotation provides support of neutral position of shoulders, arms and wrists while accommodating multiple working postures.
- Surpasses ANSI/BIFMA standards.
- Black powder coat finish.
- Patented secondary slide and unique arm design provide minimal footprint.

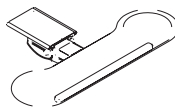

Keyboard Spacer Kit (page 286)

- Keyboard Spacer Kit required for mounting under Altitude worksurfaces.
- Kit provides ten spacers and hardware for mounting keyboard supports beneath an external worksurface support channel.
- Spacers are 2 1/8" H providing more room beneath surface for mounting.

CPU Hammock (page 286)

- Features 360-degree swivel with an 11" track.
- Load capacity is 75 lbs.
- CPU must be minimum of 3/4"W with maximum dimension of 64" in perimeter.
- Handy adjustment tool stores within unit.
- Safety feature prevents accidental release of straps and straps can be adjusted while CPU is installed.
- Can be used on Height Adjustable Tables as long as it is attached with spacer model AKMH. Take into account required leg room for users.







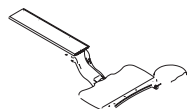
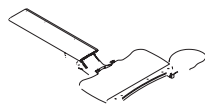



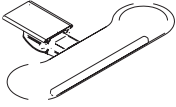

AKTMID and AKTLONG Keyboard Support (page 286)

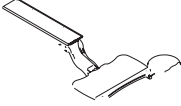
- Lift and lock intuitive height adjustment.
- Positive and negative tilt for the best ergonomic positioning.
- +10°/-20° tilt adjustment and 360° rotation provides support of neutral position of shoulders, arms, and wrists while accommodating multiple working postures.
- Non-handed mouse tray can be moved from right hand to left hand side.
- Surpasses ANSI/BIFMA standards.
- Black powder-coat finish.

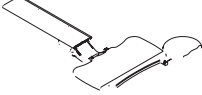

For specification information see page 285.

GSA SIN 33721

	Description	Model	List Price						
	Compact Keyboard Support with 8" Track 30"W x 13"D	AKTSHORT 	\$ 603						
	STS Keyboard Support with 23" Track 24"W x 12"D	AKTLONG 	\$ 739						
	Articulating Keyboard Support with 21" Track 24"W x 12"D	AKTMID 	\$ 635						
	Keyboard Spacer Kit 10 – 2½"H Spacers and Hardware	AKMH 	\$ 65						
	CPU Hammock™ (Silver only) 360° swivel CPU holder with adjustable straps	ACPU1 	\$ 431						
	Metal Corner Sleeve — for use with Optimize™, Concensys®, and Terrace® • Fits 1¼" thick square edge detail. (T-Mold worksurfaces) 22½"W leading edge x 18"D.	AWCS	<table border="1"> <thead> <tr> <th>P1 Paint List Price</th> <th>P2 Paint List Price</th> <th>P3 Paint List Price</th> </tr> </thead> <tbody> <tr> <td>\$ 152</td> <td>\$ 158</td> <td>\$ 163</td> </tr> </tbody> </table>	P1 Paint List Price	P2 Paint List Price	P3 Paint List Price	\$ 152	\$ 158	\$ 163
P1 Paint List Price	P2 Paint List Price	P3 Paint List Price							
\$ 152	\$ 158	\$ 163							

Edge Details

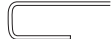

Model AWCS

How to specify —

Select the Model Number from above.



Examples: AKMH ACPU1

 Shippable by small-package carrier.

Allsteel's tool rail works in conjunction with a variety of accessories. Modular accessories free up worksurface space and provide orderly storage that is well within reach. Units can be arranged and rearranged to respond to changing workflow. The work tools that attach to the tool rail are:

- Mail Box
- Folder Holder
- Phone Caddy
- Binder Bin
- Tool Box
- Clip Caddy™
- Sidebar™ Personal Shelf
- Paper Wave™
- Cup Holder
- Hook
- Hanging File Holder
- Magnetic Picture Holder
- Small Bin
- Small Shelf
- Small Tray

Additional accessories that work with the **tool rail work tools** aesthetically are:

- Bookends
- Freestanding Mail Box

Coat hooks, marker boards and center drawers round out the organization offering.

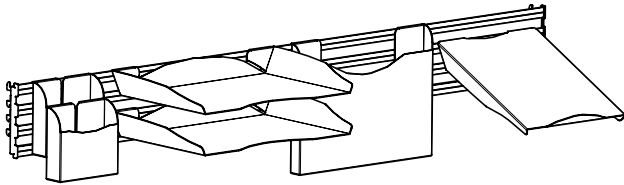

Tool rail, shown above, is height-adjustable in 1" increments using slots in panels or metal hutch. Tool rail shown with two tool boxes, two mail boxes, folder holder, and phone caddy. Folder holders and binder bins extend below a tool rail. Paper Wave and contents extend above a tool rail.

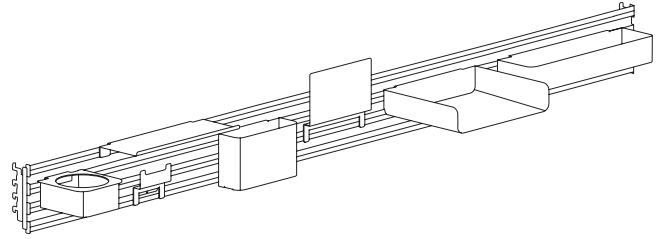

Tool rail, shown with cup holder, small shelf, hook, small bin, magnetic picture holder, small tray, and hanging file holder.

Tool Rails and Work Tools (page 290)

- Sturdy aluminum extrusion with steel support construction.
- Powder coated for durable finish.
- Use to hang Extensions tools. Cannot be used to support monitor arms.
- Suggested weight capacity not to exceed 80 lbs.
- Consideration needs to be given to height of tools and location of worksurfaces.
- For use with Terrace®, Concensys®, and Optimize™ systems.
- 5" high rail (widths coordinate with panels).
- Attachment via vertical reveals.
- Can be hung from wall track. Good solution for above copiers.
- Systems tool rail is off-modular — can be used on a panel of equal width or one size smaller.
- May span two panels of appropriate size, i.e., 60" W Tool Rail on two 30" W panels.

Tool Rail for Hutches (page 290)

- Will work on Universal, Terrace, Optimize, and Concensys system hutches produced after July 2, 2000 and Align™ metal hutches.
- Sturdy aluminum extrusion with steel support construction.
- Powder coated for durable finish.
- Use to hang Extensions tools. Cannot be used to support monitor arms.
- Suggested weight capacity not to exceed 80 lbs.
- Consideration needs to be given to height of tools and location of worksurfaces.

Mail Box (page 291)

- Holds standard letter-size paper and inter-office envelopes.
- Minimal horizontal intrusion.

Folder Holder (page 291)

- Holds manila envelopes.
- Is capable of hanging on other folder holders to maximize space.
- Stores vertically for easy access to files.

Phone Caddy (page 291)

- Holds telephone at optimum ergonomic angle.
- Wire management cut-outs.
- Accommodates standard phone sizes.

Binder Bin (page 291)

- Holds folders, binders, and manuals.

Tool Box (page 291)

- Holds pencils and other writing utensils, large post-it notes, and other desk top accessories.

Clip Caddy™ (page 291)

- Holds paper clips and other small objects.

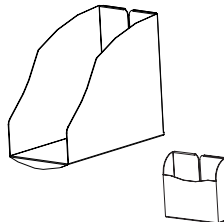
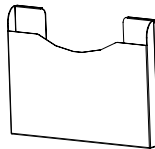



Sidebar™ Personal Shelf (page 291)

- Holds office supplies and personal effects.

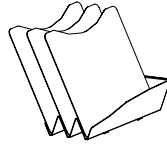

Paper Wave™ (page 291)

- Provides 3 fully divided slots for organizing files.
- Keeps papers from “bowing” at bottom.

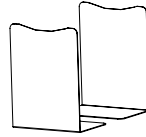

Bookends (page 291)

- Can be used on shelves or in cabinets.
- Used to hold books, binders, and catalogs upright.

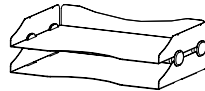

Freestanding Mail Box (page 291)

- Incorporates similar aesthetic to mounted Mail Box.
- Mounting brackets allow for free access from front and back.
- Sold in pairs of two; will stack up to eight high.
- Individual mail box dimension = 1¼”H.
- Stacking brackets are black.



Coat Hook APMC6 (page 291)

- Hangs directly into slotted Terrace® or Optimize™ panel frame.
- Use for coat or bag.
- Package of six.
- Available in black only.

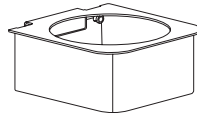

Cup Holder (page 291.1)

- Holds most cups and thermoses. Weight capacity is 5 lbs.

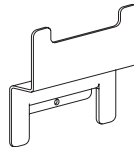

Hook (page 291.1)

- Hangs small personal effects such as headphones, keys, or hand wallets. Weight capacity is 10 lbs.



Hanging File Holder (page 291.1)

- Hangs files and folders from hanging file clips. Hanging file clips not included. Weight capacity is 5 lbs.

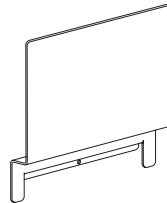

Magnetic Picture Holder (page 291.1)

- Allows for pictures to be hung via magnets. Magnets not included. Weight capacity is 5 lbs.

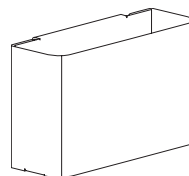

Small Bin (page 291.1)

- Houses office supplies or other personal effects such as pencils, pens, sticky notes, journals, etc. Weight capacity is 5 lbs.



Small Shelf (page 291.1)

- Provides additional shelf storage in workstation and displays office supplies or personal effects. Weight capacity is 5 lbs.



Small Tray (page 291.1)

- Holds office supplies and other personal effects. Weight capacity is 5 lbs.



ACPWRMOD

Power/Data Module — Clamp On Worksurface (page 297)

- On-surface mounting option, fits on any worksurface with a 4" overhang.
- 10' straight power cord only. UL Listed.
- Includes adapters to allow use of commercially available data terminals or blanks to fill unused openings. Many of the AMP, AT&T, Krone, Leviton, and most commercial data terminals can be used.
- Available in Fog only.

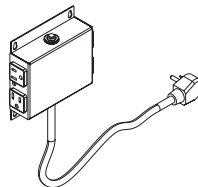

APWR4TAP

Power Module — Under Worksurface, Quad Tap (page 297)

- Under surface mounting can be used under any surface with a 5" x 5" x 1.5" clearance.
- 10' straight power cord only, no specification needed.
- 4 receptacles, unit is black finish only, no specification needed.

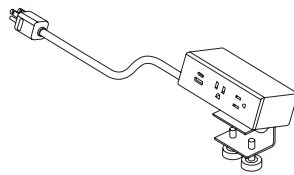

APWRMOD.AC.S

Power Modules — Clamp On Worksurface, Rectangular (page 297)

- Worksurface clamp can be used on any surface with a 2½" overhang.
- Must be installed at time of initial worksurface installation if installing between a worksurface and panel.
- 10' straight power cord only. UL Listed.
- The USB hub allows simultaneous powering of 2 receptacles, 1 USB-A device, and 1 USB-C device. The USB hub is a charger only, no ability to connect to a PC. The charging capacity is limited and may not charge all devices.
- Four wire management "P-Clips" included with mounting hardware.
- Specify "QA" for Qi compatible wireless charging on AWPRMOD. USB-C port no longer included when wireless charging specified.
- Available in Snow and Storm finishes.

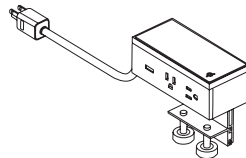

APWRMOD.QA.S

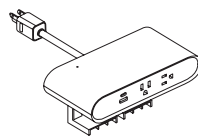

ARNDPWRMOD.QA.S

Power Modules — Clamp On Worksurface, Round (page 297)

- Worksurface clamp can be used on any surface with a 2½" overhang.
- Must be installed at time of initial worksurface installation if installing between a worksurface and panel.
- 9' straight power cord only. UL Listed.
- The USB hub allows simultaneous powering of 1 USB-A device and 1 USB-C device. The USB hub is a charger only, no ability to connect to a PC. The charging capacity is limited and may not charge all devices.
- Specify "QA" for Qi compatible wireless charging on ARNDPWRMOD.
- Available in Snow and Storm finishes.

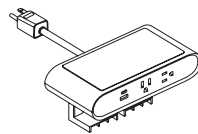

ARNDPWRMOD.AC.S

Power Module — Under Worksurface, Rectangular (page 297)

- Under surface mounting can be used on any surface with a 5" clearance.
- Power cord choices include 10' Straight, 5' Interlink, 10' Hardwire, and 10' Chevron Fog & Storm Braided cords. All are UL listed.
- Four wire management "P-Clips" included with mounting hardware.
- Available in Snow, Storm, and Black finishes.

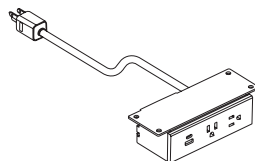

AUPWRMOD.AC.S

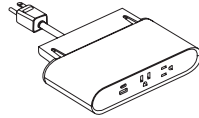

AURNDPWRMOD.AC.S

Power Module — Under Worksurface, Round (page 297)

- Under surface mounting can be used on any surface with a 5" clearance.
- 9' straight power cord only. UL Listed.
- Available in Snow, Storm, and Black finishes.

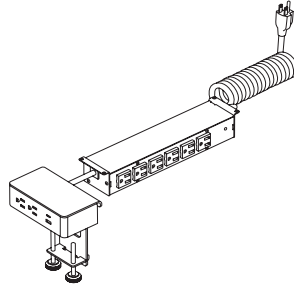

AABPWRMOD.AC.Q

Power Module — Above/Below Worksurface (page 297)

- Above/Below power module provides access to power on the desktop and below the worksurface.
- Desktop mount can be used on any surface with a 6"W x 3"D clearance along the worksurface edge.
- Under surface mounting can be used with a 12"W x 3"D x 2"H clearance under the surface.
- Plugs will take additional depth (approx. 3").
- Two wire management "P-Clips" included with mounting hardware.
- Below worksurface power strip supplies six grounded A/C receptacles, desktop unit supplies two receptacles, 1 USB-A port, and 1 USB-C port.
- Desktop and under worksurface units are connected by a 2' long straight cord and cannot be disconnected.
- Power cord choices include a 6' straight cord or a coiled cord that is 6' long uncoiled, approximately 8" long coiled (compressed).
- Desktop unit available in White and Gray finishes.
- Under worksurface unit available in black only, no specification needed.
- UL 962A and UL 111 Listed. UL 1310 Recognized.

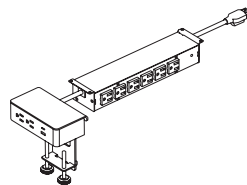

AABPWRMOD.AC.S

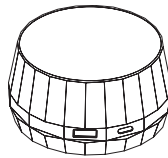

APWRPCK

Power Module — Sit-on-Surface, Puck (page 297.1)

- Unit sits on top of a worksurface.
- Includes 5' DC Connector cord, transformer block, and 6' AC straight cord for 11' of total cord length. UL 1310 Listed.
- Unit allows for simultaneous powering of 1 USB-A and 1 USB-C device.
- Unit is a charger only, no ability to connect to a PC other than to charge.
- Available in White and Silver finish only, no specification needed.

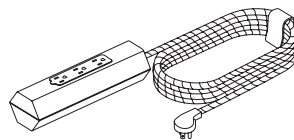

APWRSTRP

Power Strip — Sit-on-Surface, Wood (page 297.1)

- Unit sits on top of a worksurface.
- 10' Braided cord in White nylon, leather cord management strap included. UL Listed.
- Ultra-low profile 45 degree flat plug.
- 3 grounded power outlets.
- Solid Ash Wooden housing, no specification needed.



AVSTA3PWR

Vesta Mobile Power (page 297.1)

- 3 AC power simplex, 1 dual USB-A, 1 USB-C configuration.
- 10' Retractable power cord, UL Listed.
- Unit weighs 13 lbs.
- For cordless, battery-powered unit, please contact the Tailored Product Group (TPG).
- Available in Snow, Storm, Black, and Fog. Separate finish options available for outside and inside of unit.

Cable & Wire Management

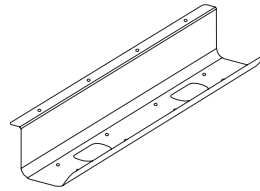

AJTRGH24 or AJTRGH36

Cable Management Tray (page 297.2)

- Attaches under the worksurface to contain cables.
- Metal tray shelf is 4" deep. Can hold electrical power strip and/or surge protector.
- 24" and 36" lengths, use multiple units for larger worksurfaces.
- Attachment hardware included, paint option is black only.
- Zip tie attachment points located in base of tray. Zip ties not included.

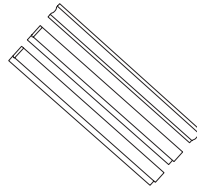

AWRSTRIP

Wire Management Strips/Channels (page 297.2)

- Self adhesive backing to attach to panels and underside of worksurfaces.
- Flexible strips allow cabling to enter/exit and can be contained inside the strips' cavities.
- Includes two wire management profiles. Smaller profile allows for qty. 3, .3" diameter cords, has area of .32 in². Larger "J" shaped profile allows for qty. 10, .3" diameter cords, has area of 1.14 in².

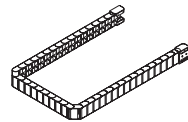

A9CLWMC or WKSWMC

Cord Management Chains (page 297.2)

- Works with Approach and Altitude A6-units.
- Used to route and conceal power/data cables from control box and other devices. Includes all mounting hardware and a plate to secure to a leveling glide.
- Houses 6 cables at 0.300" diameter.
- Made of plastic chain with plastic attachment brackets at each end.
- Specify WKSWMC for 58" chain. Only comes in Black finish.
- Specify A9CLWMC for 36" chain. Comes in Black, White, and Silver.
- Has two connecting points: Top section connects underneath a worksurface and bottom section can connect underneath power rails or to panel raceways using double-sided tape. Hardware included.

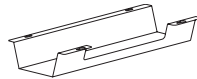

APWRTRGH17 or APWRTRGH36

Under Worksurface Trough (page 297.2)

- Used to conceal wires and control box below worksurfaces. Trough can be configured at various height/width combinations to meet capacity needs. Ships flat and is bent to desired shape.
- On 48"W and 54"W worksurfaces use one 17"W trough. 54"W has space to use 2 – 17"W, if necessary.
- On 60"W, 66"W, and 72"W worksurfaces use the 36" trough.
- On 84"W worksurface use 2 – 17"W troughs.

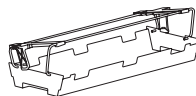

AFDTRGH20

Flip-Down Wire Trough (page 297.2)

- Mounts beneath a worksurface. Used to conceal extra cord slack and power strips.
- May be used in conjunction with quad tap unit APWR4TAP to reduce the number of cords routed from a worksurface to a beam.
- For any worksurface less than 58"W, a 20"W Flip-Down Trough is recommended.
- For worksurfaces 58"W and wider, a 20"W or 32"W Flip-Down Trough may be used.
- Flush-mount Raddi Storages are not recommended to use in conjunction with Flip-Down Trough.
- Only AKTSHORT keyboard tray is recommended for use in conjunction with the Flip-Down Trough.



AFDTRGH32

O-Leg Chase (page 297.3)

- Works with O-Legs from Allsteel Approach.
- Matches leg profile on models WKTBTTL2824 and WKTBTTL2830.
- Magnetically aligns and adheres itself to the inside of the leg and allows for user to reposition and adjust wires as needed without the use of tools.
- Metal chase measures 26"H, can fit qty. 12, .3" diameter cords. Has cross section area of 1.56 in².
- Available in standard metal paint finishes.



ALEGCHASE26

Cable & Wire Management

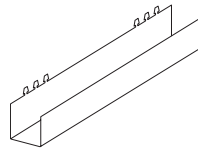

AMPCHASE

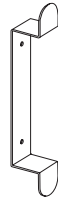

AWIRECLT

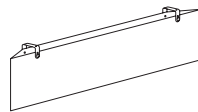

APWRMODEST36 or APWRMODEST48

Panel Mounted Wire Chase (page 297.3)

- Attaches between panels on Stride, Terrace, and Optimize via a slotted standard.
- Designed to sit below a worksurface and provide additional cord management from the base rail to beltline/under-worksurface height.
- Available in standard metal paint finishes.

Metal Wire Cleat (page 297.2)

- Supplied with screws and VHB tape for attachment to various surface types.
- For wood/particle board/MDF surfaces, use screw attachment.
- For painted metal/glass/non-porous surfaces, use VHB tape.
- Example use cases:
 - 1) Used alongside telescoping/fabric HAT wire chases to secure excess length of cord at plug-end.
 - 2) Secured to wall next to TV monitor in meeting room to manage HDMI cable when not in use.
 - 3) Screwed underneath worksurface to provide quick and easy management of excess length of cords and cabling.

Fabric Power Modesty (page 297.4)

- Fabric Power Modesty presents as modesty panel hanging by leather straps under a worksurface; inner compartment conceals cords and power strips as a wire management application.
- Recommended worksurface width pairings:
 - 1) 48-60" W Desk — Use APWRMODEST36 Centered.
 - 2) 66-72" W Desk — Use APWRMODEST48 Centered or APWRMODEST36 offset.
 - 3) 84" W Desk — Use APWRMODEST48 offset.
- Modesty fills 11.5 inches below the bottom of the worksurface with space for cords to enter/exit between the worksurface and the top of the Power Modesty.
- Two entry/exit points for cords are located at the bottom of the Power Modesty unit.
- Modesty panel is designed to present as a thin modesty panel from the front, but provides 3" depth cavity for wires, power strips, etc.
- Maximum weight capacity for Power Modesty is 25 lbs.
- Modesty panel not to be used to store electronics that require airflow for thermal management (computers).
- Users can access interior of panel (to modify wire placement) via "wings" on either side of product, secured via user-operable Velcro connection.
- Users may also dismount Power Modesty from leather straps by unlooping leather straps from button attachments.
- Leather straps on Power Modesty always come in medium brown color.
- Power Modesty available in Appoint, Binary, Centurion, Noble, Reflections, Disperse, and Spin fabric series.

Cable & Wire Management

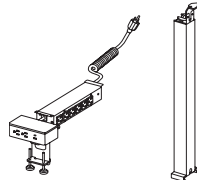

AHATPWORMOD2S or AHATPWORMOD3S

Metal Telescoping HAT Wire Management (page 297.4)

- Separate models available for use on either 2-Stage or 3-Stage Altitude A6 Tables. Not compatible with Altitude A3, A5, or A8.
- Equipped with 2-Stage or 3-Stage Telescoping Wire Chase and custom Above/Below Power Module intended for cord management on 2- and 3-Stage height adjustable tables.
- Telescoping chase includes a unique Above/Below Power Module and is NOT compatible with any other power module.
- Above/Below Power Module supplies 6 grounded A/C receptacles below the worksurface and 2 receptacles, 1 USB-A, and 1 USB-C port above the worksurface on the desktop unit. Desktop power module available in White and Gray finishes, below-worksurface power strip only available in black only.
- Telescoping Chase available in the same paint finishes as the Altitude height adjustable bases except for “Nickel.”
- To match Metal Telescoping Chase to HAT base, specify matching paint color as HAT base. To match Telescoping Chase to a “Nickel” HAT base, specify “Platinum Metallic,” or “PR2.”
- Two “P-Clips” included for wire management between desktop power module and under worksurface power strip.

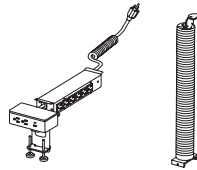

AHATPWORMOD2S or AHATPWORMOD3S

Fabric Elastic HAT Wire Management (page 297.4)

- Model compatible for use on either 2-Stage or 3-Stage Altitude A6 Tables. Not compatible with Altitude A3, A5, or A8.
- Equipped with Fabric Elastic Wire Chase and custom Above/Below Power Module intended for cord management on 2- and 3-Stage height adjustable tables.
- Fabric Elastic Chase includes a unique Above/Below Power Module and is NOT compatible with any other power module.
- Above/Below Power Module supplies 6 grounded A/C receptacles below the worksurface and 2 receptacles, 1 USB-A, and 1 USB-C port above the worksurface on the desktop unit.
- Desktop power module available in White and Gray finishes, below-worksurface power strip only available in black only.
- Fabric Elastic Chase available in Light, Medium, and Dark fabric finishes.
- Includes a metal foot and an under worksurface mounting bracket to attach Fabric Elastic Chase along the side of a HAT leg.
- To match metal brackets to HAT base, specify matching paint color as HAT base. To match brackets to a “Nickel” HAT base, specify “Platinum Metallic,” or “PR2.”
- Two “P-Clips” included for wire management between desktop power module and under worksurface power strip.

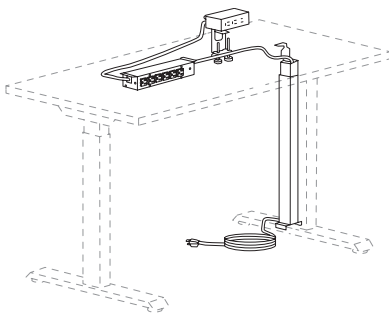

2-Stage Metal Telescoping HAT Wire Management

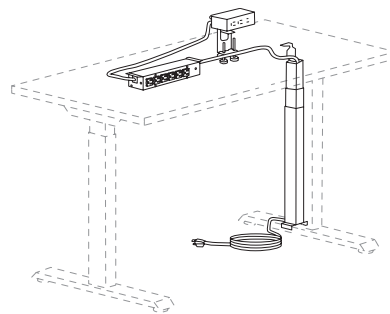

3-Stage Metal Telescoping HAT Wire Management

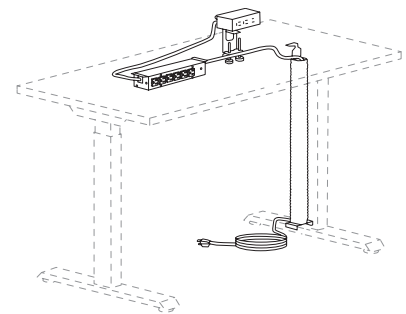

2 or 3-stage Fabric Elastic HAT Wire Management

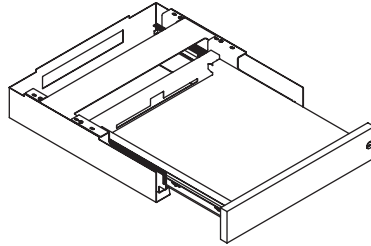
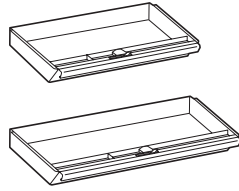

Flat Brackets

Front View

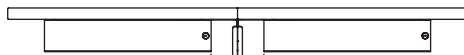

Top View

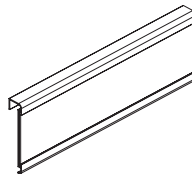
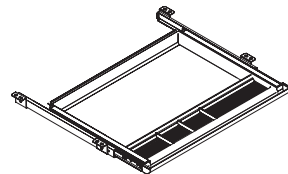
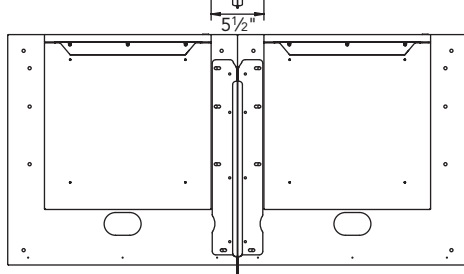

Metal Center Drawers (page 292)

- All metal center drawers feature pencil trays with three compartments for storage.
- Center drawers will not fit in center of 24" D worksurfaces which are wider than 60" due to location of center support bracket.
- For locking specifications, see pages 302-304.
- Ball-bearing slide suspension.

Laptop Drawer — U7WDA (page 292)

- Drawer body made of sheet metal.
- Drawer front made of 3/4" particleboard with laminate on both sides and fused laser edge banding.
- Core removable lock is located on right side drawer front
- 17 5/8" W x 18" D x 3 3/8" H Outside (interior 13" W x 16" D x 1 7/8" H)
- Minimum surface depth is 21" for surfaces not using an external stiffener; and 27" for surfaces using an external stiffener.
- Drawer extends 16"
- Maximum load: 45 lbs (functional BIFMA load)
- Drawer assembly and cover have cut out in back to allow for cables to exit drawer.
- Distance from floor to bottom of unit w/glides fully retracted is 24 3/4".
- Does not interfere with Further leg mounting plates so drawer can be placed directly next to either a system or table leg.
- When being placed next tower storage using the tower ell bracket (Z6LB) to support surface the drawer must be inset 3" to clear the ell bracket.
- Can be placed directly next to any support storage from any Allsteel product line (excluding towers).
- Flat brackets — drawer must be offset 3" from seam between surfaces to clear the bracket. See illustration at left.
- Can be used with rabbit edge worksurface models but there will be a larger reveal between surface and drawer.
- Can be used with knife edge worksurface models but reveal and depth need to be considered.

Polymer Center Drawer - ACD1 (page 292)

- 20 1/2" W x 17" D x 2" H
- Available in black only
- Made from ABS.
- Minimum clearance for mounting: 23" W x 16 1/4" D x 2" H.
- Retracts on 16" ball-bearing slides.
- Can be used on worksurfaces with Height Adjustable Bases as long as it is attached with spacer model AKMH.
- Can store up to 25 lbs.

Name Plate (page 291)

- Comes in a 10-pack.
- Metal backer installs under a Terrace or Optimize top cap, can be used with frameless glass.
- Cover is a transparent polycarbonate insert.
- Full plate is 8 1/2" W x 2 5/8" H.

For specification information see pages 287-288.

GSA SIN 33721

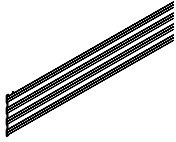
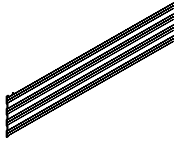

Description	Model	P1 Paint List Price	P2 Paint List Price	P3 Paint List Price
5"H Tool Rails — for Panels				
24"W	EASR24	\$ 267	\$ 305	\$ 340
30"W	EASR30	\$ 283	\$ 321	\$ 356
36"W	EASR36	\$ 295	\$ 333	\$ 368
42"W	EASR42	\$ 308	\$ 346	\$ 381
48"W	EASR48	\$ 317	\$ 355	\$ 390
60"W	EASR60	\$ 373	\$ 411	\$ 446
5"H Tool Rails — for Metal Hatches				
36"W	EAHSR36	\$ 295	\$ 332	\$ 366
42"W	EAHSR42	\$ 308	\$ 345	\$ 379
48"W	EAHSR48	\$ 317	\$ 354	\$ 388
60"W	EAHSR60	\$ 373	\$ 410	\$ 444
66"W	EAHSR66	\$ 385	\$ 422	\$ 456
72"W	EAHSR72	\$ 415	\$ 452	\$ 486

How to specify —
Select the Model Number from above.

1st Option:

Paint:



See page 68 for finishes.







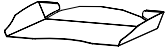
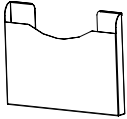

_____. **P**_____

Example: EASR36.P02

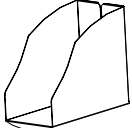
Shippable by small-package carrier.

For specification information see pages 287-288.

GSA SIN 33721

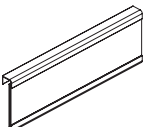
	Description	Model	P1 Paint List Price	P2 Paint List Price	P3 Paint List Price
	Mail Box 9"D x 15"W	EAPT S	\$ 132	\$ 152	\$ 168
	Folder Holder 9"H x 12"W	EAFS S	\$ 135	\$ 155	\$ 171
	Phone Caddy 9"W x 11"D	EATS S	\$ 165	\$ 185	\$ 201
	Binder Bin 8½"H x 5¼"W x 10"D	EABS S	\$ 132	\$ 152	\$ 168
	Tool Box 5"H x 5¼"W x 1½"D	EADH S	\$ 106	\$ 126	\$ 142
	Clip Caddy™ 2"H x 7"W x 3½"D	EAAC S	\$ 94	\$ 114	\$ 130
	Sidebar™ Personal Shelf 2"H x 21"W x 7"D	EAPS S	\$ 135	\$ 155	\$ 171
	Paper Wave™ Tray size: 2½"H x 6"W x 10"D Dividers: 9½"H x 9"W	EASS S	\$ 189	\$ 209	\$ 225
	Freestanding Mail Box (specify paint color) Pair — 4½"H x 13¼"W x 9"D	EAFT S	\$ 271	\$ 291	\$ 307
	Coat Hooks (black only) Package of six	APMC6 S	\$ 132	N/A	N/A
	Panel Name Plate Package of 10	EACS	\$ 360	\$ 380	\$ 396
	Note: Not for use on tool tile or rail, name plate installs under top cap on Terrace and Optimize.				

How to specify —
Select the Model Number from above.

1st Option:
Paint:
P1
P2
P3
 See page 68 for finishes.

_____ .



P _____

Examples: EAPT.P4J APMC6.P

S Shippable by small-package carrier.

For specification information see pages 287-288.

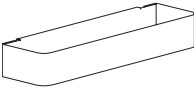
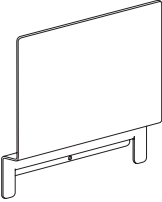
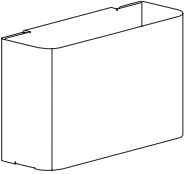
GSA SIN 33721

	Description	Model	P1 Paint List Price	P2 Paint List Price	P3 Paint List Price
	Cup Holder 4 $\frac{1}{8}$ "H x 2"W x 11 $\frac{1}{8}$ "D	AAPAC S	\$ 259	\$ 285	\$ 298
	Hook 4 $\frac{1}{8}$ "H x 3 $\frac{3}{8}$ "W x 7 $\frac{1}{4}$ "D	AAPAH S	\$ 195	\$ 215	\$ 224
	Hanging Folder Holder 4 $\frac{7}{8}$ "H x 2 $\frac{1}{2}$ "W x 14"D	AAPAHF S	\$ 258	\$ 284	\$ 297
	Magnetic Picture Holder 9"H x 10"W x 10 $\frac{1}{2}$ "D	AAPAMP S	\$ 231	\$ 254	\$ 266
	Small Bin 5 $\frac{1}{8}$ "H x 3 $\frac{3}{8}$ "W x 7 $\frac{1}{4}$ "D	AAPASB S	\$ 237	\$ 261	\$ 273
	Small Shelf 4 $\frac{1}{8}$ "H x 2"W x 11 $\frac{1}{8}$ "D	AAPASH S	\$ 222	\$ 244	\$ 255
	Small Tray 8 $\frac{3}{8}$ "H x 2 $\frac{7}{8}$ "W x 10 $\frac{1}{4}$ "D	AAPAST S	\$ 260	\$ 286	\$ 299

How to specify —
Select the Model Number from above.

_____ .

1st Option:
Paint:
P1 P2 P3
See page 240 for finishes.

P _____

Examples: AAPAST.P4J AAPASB.P

S Shippable by small-package carrier.

allsteeloffice.com | 291.1

For specification information see pages 288-289.

GSA SIN 33721

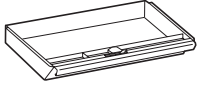
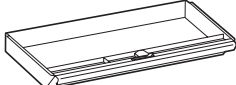
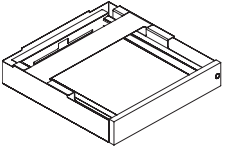
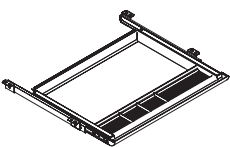
	Description	Model	List Price		
			P1	P2	P3
 <p>Angled front</p>	Metal Center Drawer w/Lock 19"W x 14¼"D x 3"H • 12" drawer extension (3/4). • Inside drawer dimension: 19"W x 13"D x 2⅝"H. • Minimum clearance for mounting: 21¼"W x 19¼"D.	CSDC19 <input type="checkbox"/>	\$ 305	\$ 327	\$ 346
 <p>Angled front</p>	24½"W x 14¼"D x 3"H • 12" drawer extension (3/4). • Inside drawer dimension: 24½"W x 13½"D x 2⅝"H. • Minimum clearance for mounting: 27⅝"W x 19¼"D.	CSDC25 <input type="checkbox"/>	\$ 314	\$ 336	\$ 355
	Laptop Drawer — Locking, laminate front, metal case 17⅝"W x 18"D x 3⅜"H • 16" drawer extension • Inside drawer dimensions: 13"W x 16"D x 1⅞"H • Minimum clearance for mounting: 17⅝"W x 21"D x 3⅜"H (see illustration)	U7WDA <input type="checkbox"/>	\$ 1750	\$ 1773	\$ 1792
	Polymer Center Drawer 20½"W x 17"D x 2"H • 11½" extension • Minimum clearance for mounting: 23"W x 16¼"D x 2"H	ACD1	\$ 244	N/A	N/A

How to specify —
Select the Model Number from above.

1st Option:
Laminate Edge
(Laptop drawer front if applicable):
See page 68 for finishes.

2nd Option:
Edge
(Laptop drawer edge if applicable):
See page 68 for finishes.

3rd Option:
Paint
(If laptop drawer, list exterior case color here):
See page 68 for finishes.
Power Data Module
PR6 Silver.

4th Option:
Paint
(Interior of laptop drawer if applicable):
See page 68 for finishes.

5th Option:
Lock
(if applicable):
STD Standard
OMT Omit (Deduct \$20)

6th Option:
Lock or Tech Module Color
(if applicable):
EL Silver (Lock)

Example: U7WDA.LM11EV.P27.PR6.STDEL

Shippable by small-package carrier.

Allsteel Extensions offers Illumination in three styles — Undercabinet LED Light, Wand Light, and Splitty Light.

Recessed Undercabinet LED Light

Recessed task lights conserve space and provide an efficient solution for illuminating the workplace. All models are equipped with LED strips.

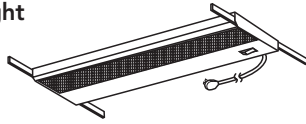

Recessed task light models mount under storage cabinets or shelves to provide optimal space utilization. Models are available in two styles and three sizes to correspond with the width of the cabinet or shelf. Task lights with a fused plug are available to meet Chicago electrical code.

Undercabinet LED Light

The Undercabinet LED Light is a low-profile, linear solution for overhead cabinets and shelves and is an ideal solution for painted wood storage. It utilizes energy-efficient LED technology which provides a long life. The Undercabinet LED Light provides the opportunity to mount the fixture where light is needed most.

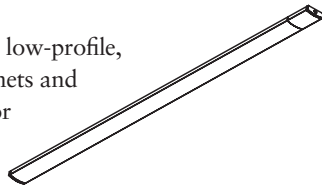

The Undercabinet LED Light features a metal trough reflector with diffuser lens. The light has a sleek 1/2" thick profile and provides two options for mounting, either magnetically or with hardware. Undercabinet LED Lights can be daisy-chained.

Optional undercabinet occupancy sensor is available which will automatically turn off the fixture after 30 minutes of no detection and back on immediately as the user re-enters the detection range using Passive Infrared (PIR) sensor technology. Unit features 360° lens with 90° outward detection angle, providing a 36" coverage diameter at 18". Occupancy sensor comes with connector and is required to be connected in the sequence shown below. Connect occupancy sensor to a light, or first light in daisy chain to control all linked lights.

CONNECTION SEQUENCE*

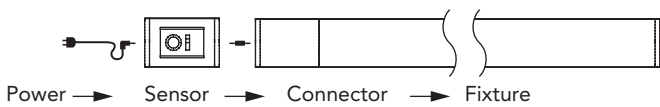

*Cannot deviate from this sequence

Recessed Task Lights (page 295)

- Black Metal Construction with 9' long black cord attached to right rear corner of the fixture.
- LED strip comes installed within light.
 - 50,000 hour life span
 - 120V-277V
 - CCT 4000K
 - CRI 80+
- Includes 4 cord retainer clips.
- Shorter width models can be used on wider overheads, shelves and hutches.
- On/Off switch provides individual control of tasklight within the workstation.
- Daisy chain models require a master control model — 10 fixtures maximum.
- RECOMMENDATION: Provide a separate circuit for task lights to ensure proper, long-term operation.

Undercabinet LED Lights (page 295)

- Low profile energy-efficient LED task light for use with overhead storage cabinets and shelves.
- 20W power supply for 10W 17" unit (.166 amps).
- 20W power supply for 20W 31" unit (.166 amps).
- 60W power supply for daisy-chain starter units (.5 amps). Must order one starter unit for each daisy-chain application.

LED Light Combinations Must Not Exceed 60W in Combination	Power Usage
6X 17"	60W
3X 31"	60W
1X 31" + 4X 17"	60W
2X 31" + 2X 17"	60W

- The combinations that could max out 60W are featured above. *Daisy chained units have a power limit of 60W from one power entry. 17W units use 10W and 31W units use 20W.*
- Specify up to 5 additional 17" interconnect units (ALED17UJMP30) to daisy-chain together with 17" daisy-chain starter fixture (ALED17U60).
Example: Daisy-chain 4-17" undercabinet LED lights:
Specify: 1 ALED17U60
Specify: 3 ALED17UJMP30 with 10" jumper cord
- Specify up to 2 additional 31" interconnect units (ALED31UJMP30) with 10" jumper cords to daisy-chain together with 31" tasklight (ALED31U60); or 17" daisy-chain starter fixture (ALED17U60).
- 3500K color temperature.
- 131 footcandles at 18" on ALED31U; 76 footcandles at 18" on ALED17U.
- Magnetic or screw-mount option — attachment hardware included.
- On 20 watt models, power drive is attached to plug: allow 1 1/8" D space at outlet.
- On 60 watt models, power drive brick is in center of cord.
- Includes 3 cord retainer clips.
- Meets California Title 24 Energy Efficiency Standards.
- "Instant On" switch with infinite dimming cycle from 100% to 15% with the last state memory, allowing the user to set their desired level of lighting.
- Fixture automatically turns off after 10 hours of use to reduce unwanted energy use.
- Optional occupancy sensor automatically turns off all interlinked fixtures after 30 minutes of no detection and back on immediately when detection is found.

Overhead Length	Suggested LED Sizes
24	17
30	17
36	17
42	31
48	17 + 17
60	31 + 17
72	31 + 31

Note: LED lights may need to be positioned along length properly to allow jumping to additional overheads. Suggested sizes above are recommendations for single overheads to provide as much light along length of overhead as possible.

The suggested sizes factor in 4 inches of room for the power inlet and occupancy sensor (optional).

Wand™ Task Light

Wand freestanding task light offers a clean, simple design along with powerful LED technology to illuminate the workspace. The swivel base and arm tilt allow users to position the light just where they need it. The 7.7 watt LED light offers efficiency and long life, providing up to 25 years of daily use. The slim, sleek design makes it easy to integrate into any workspace. Wand task light is 97% recyclable. Occupancy sensor and/or charging models available.

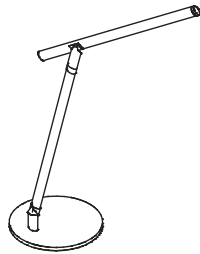

Wand LED Freestanding Task Light (page 296)

- Available in Silver or White. 9'4" cord is Silver.
- Full range dimming from 100% – 10% with last state memory.
- Uses 5W at highest setting and as low as 1 watt at its lowest setting, providing 75 to 12.7 footcandles of light, respectively (16" above worksurface).
- 7½" round swivel base and 16½"H tilt arm allow versatile positioning of the 13" lampshade.
- Designed for 50,000 hours of life.
- Color Temperature: 3500K. Color Rendering Index (CRI): 80.
- Materials: aluminum arm and lampshade, steel base.
- Weight: 4.4 lbs. 97% recyclable, 76% post-consumer.
- Certifications: UL and CUL. TAA compliant.
- Occupancy sensor available with automatic shut-off after 15 minutes if no motion is detected.
- USB model features USB-A (1), USB-C (1) charging within base of unit.
- USB model also features occupancy sensor. 7.5W (A) & 18W (C) power consumption.

Splitty Task Light

Splitty's organic and modern design compliments the workstation while also bringing rich features to the user. In addition to illuminating the space, Splitty can also be a teleconferencing tool through Splitty's 360-degree light head adjustment and soft touch, continuous dimming. Integrated charging allows for small personal device charging crucial to the modern worker's workplace toolkit while minimizing clutter within the station. Optional clamp or tool tile mounts available as accessories.

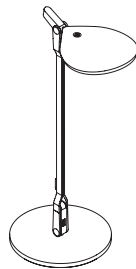

Splitty Task Light (page 296)

- Available in Silver, White, or Black (accessories available in silver only).
- Cord is 12' long.
- Cord is silver when black or silver finish specified, white when white light is specified.
- Soft touch on/off, dimming.
- Continuous dimming (100% – 3%) with last state memory.
- 5.8W of energy consumption. 7W at highest setting, 0.6W at lowest.
- 5" 360-degree swivel light head, 6.54" round swivel base and 17"H arm. Arm has full 180 degree rotation and 360 degree swivel.
- Designed for 60,000 hours of life.
- Color Temperature: 3500K, Color Rendering Index: 90.
- Materials: aluminum, plastic.
- USB-A has 5W of power consumption.
- USB-A (1) charging at bottom of light arm stem. Charging feature compatible for any mounting method.
- Clamp mount compatible with surfaces ¼" – 2¼" thick.
- Tool tile mount has 1½" adjustment range, minimum slot height of ⅜".

For specification information see pages 293-294.

Open Market / GSA SIN 33721 (as noted)

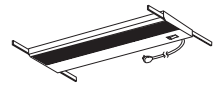

Open Market

Description	Watt Usage	Model	List Price
Recessed Task Lights (Black only) — Use recessed under overhead cabinets, storage shelves, or hutches, comes with cord retainer clips			
Task Light for 24"W	10	A870824	\$ 442
Task Light for 30"W and 36"W	14	A870830	\$ 446
Task Light for 42"W and 48"W	21	A870842	\$ 483
Task Light for 60"W, 66"W, and 72"W	28	A870860	\$ 522

Recessed Task Lights (Black only) — With fused plug (satisfies Chicago electrical code)

Task Light for 24"W	10	A870824CH	\$ 570
Task Light for 30"W and 36"W	14	A870830CH	\$ 581
Task Light for 42"W and 48"W	21	A870842CH	\$ 618
Task Light for 60"W, 66"W, and 72"W	28	A870860CH	\$ 654

Note: See below for GSA Approved Task Lights.

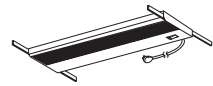

GSA SIN 33721

GSA Recessed Task Lights — Use recessed under overhead cabinets, storage shelves, or hutches

Base Models — Stand Alone

Task Light for 24"W	15	GS870924	\$ 565
Task Light for 30"W and 36"W	17	GS870930	\$ 583
Task Light for 42"W and 48"W	25	GS870948	\$ 627
Task Light for 60"W, 66"W, and 72"W	32	GS870960	\$ 671



GSA SIN 33721

Cord Retainer Clips (Black only)

Bag of 50 clips		AAPACM2	\$ 56
-----------------	--	---------	-------

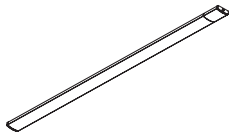

GSA SIN 33721

LED Undercabinet Light (white end caps)

17" Task Light w/20 watt power supply for 24"W or wider overhead	ALED17U	\$ 1045
17" Task Light w/60 watt power supply for daisy chain	ALED17U60**	\$ 1144
17" 10 watt Interconnect Task Light w/10" Jumper Cord	ALED17UJMP30	\$ 807
31" Task Light w/20 watt power supply 36"W or wider overhead	ALED31U	\$ 1568
31" Task Light w/60 watt power supply for daisy chain	ALED31U60**	\$ 1653
31" 20 watt Interconnect Task Light w/10" Jumper Cord	ALED31UJMP30	\$ 942
Undercabinet Occupancy Sensor 2 3/4"W + 1"W Connector	ALEDOCC*	\$ 636

*Undercabinet Occupancy Sensor works with LED Undercabinet lights shipped after 11/1/2013.

**When purchased separately without a configurable TAA compliant end product, not on GSA contract.

<p>How to specify — Select the Model Number from above.</p>	<p>1st Option: Cord Retainer Clip Color: Black only.</p>
<p>_____ . P 2 7 </p>	

Examples: A870824 GS870924 AAPACM2.P27

A870824CH ALED17U

Shippable by small-package carrier.

For specification information see pages 293-294.

Open Market / GSA SIN 33721



GSA SIN 33721

Description	Model	List Price
Wand™ LED Task Light (Silver or White)		
Freestanding LED Task Light	WANDFS <input type="checkbox"/>	\$ 509
Freestanding LED Task Light (Occupancy Sensor)	WANDFSOC <input type="checkbox"/>	\$ 724

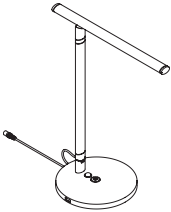

Freestanding LED Task light (Occupancy Sensor & Charging)	WANDFSUSB	\$ 754
---	-----------	--------



Splitty Task Light (Silver, White, or Black)		
Freestanding LED Task Light (Charging)	PRFTSKFS	\$ 690

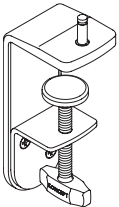

Clamp Mount (Silver only)	PRFTSKCL	\$ 80
---------------------------	----------	-------

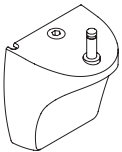

Tool Tile Mount (Silver only)	PRFTSKTR	\$ 80
-------------------------------	----------	-------

How to specify —
Select the Model Number from above.

1st Option:

Color (for Splitty):

SVR Silver
WHT White
BLK Black

(for Wand LED):

SVR Silver
WHT White

Example: WANDFS.WHT

Shippable by small-package carrier.

For specification information see page 288.1-288.2.

GSA Reference Page

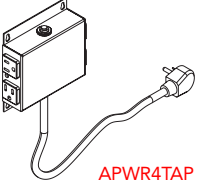
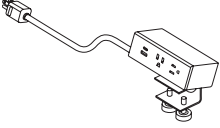
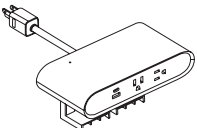
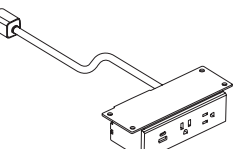
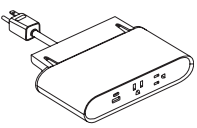
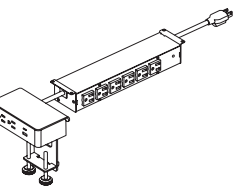
	Description	Model	List Price
 ACPWRMOD	Power/Data Module — Clamp On Worksurface 8"W x 7"D x 5½"H <ul style="list-style-type: none"> • 2 receptacles, 2 data terminals/blanks • 10' straight power cord only. UL Listed. • Available in Fog only, specify ACPWRMOD.FOG 	ACPWRMOD S	\$ 515
 APWR4TAP	Power/Data Module — Under Worksurface, Quad Tap 7"W x 12"D x 3"H <ul style="list-style-type: none"> • 4 receptacles • 10' Straight cord only, no specification needed. • Available in Black only, no specification needed. • Example: APWR4TAP 	APWR4TAP S	\$ 456
 APWRMOD.AC.S	Power Modules — Clamp On Worksurface, Rectangular 7½"W x 12¼"D x 5⅜"H <ul style="list-style-type: none"> • 2 receptacles, 1 USB-A, & 1 USB-C (AC) • Specify "QA" for 2 receptacles, 1 USB-A, & Qi wireless charging. • 10' Straight cord only (S). • Available in Snow (SNW) & Storm (STRM). • Example: APWRMOD.AC.S.SNW 	APWRMOD S	\$ 761
 ARNDPWRMOD.QA.S	Power Modules — Clamp On Worksurface, Round 8¼"W x 16"D x 4½"H <ul style="list-style-type: none"> • 2 receptacles, 1 USB-A, & 1 USB-C (AC) • Specify "QA" for 2 receptacles, 1 USB-A, 1 USB-C, & Qi wireless charging. • 9' Straight cord only (S). • Available in Snow (SNW) & Storm (STRM.) • Example: ARNDPWRMOD.AC.S.SNW 	ARNDPWRMOD S	\$ 713
 AUPWRMOD.AC.S	Power Module — Under Worksurface, Rectangular 7⅞"W x 9¼"D x 5⅜"H <ul style="list-style-type: none"> • 2 receptacles, 1 USB-A, & 1 USB-C (AC) • Power cord choices include a 10' Straight (S), 5' Interlink (I), 10' Hardwire (H), and 10' Chevron Fog & Storm Braided (B) cord. • Available in Snow (SNW), Storm (STRM), & Black (BLK). • Example: AUPWRMOD.AC.S.BLK 	AUPWRMOD S	\$ 761
 AURNDPWRMOD.AC.S	Power Module — Under Worksurface, Round 8¼"W x 16"D x 4½"H <ul style="list-style-type: none"> • 2 receptacles, 1 USB-A, & 1 USB-C (AC) • 9' Straight cord only (S). • Available in Snow (SNW), Storm (STRM), & Black (BLK). • Example: AURNDPWRMOD.AC.S.BLK 	AURNDPWRMOD S	\$ 713
 AABPWRMOD.AC.S	Power Module — Above/Below Worksurface 8¼"W x 16"D x 4½"H <ul style="list-style-type: none"> • Desktop unit includes 2 receptacles, 1 USB-A, & 1 USB-C (AC) • Under worksurface unit includes 6 receptacles. • Power cord choices include a 6' Straight cord (S) or Coiled cord (Q). • Desktop unit available in White (DWT) or Gray (DGY). • Example: AABPWRMOD.AC.S.DWT 	AABPWRMOD S	\$ 1234

<p>How to specify — Select the Model Number from above.</p>	<p>1st Option: Ports (Final port option if applicable): AC USB-A+C QA Wireless Charging with 1 USB-A port (+\$125)</p>	<p>2nd Option: Cord Type (Power Module cord type if applicable): S Straight Cord B Braided Chevron Fog & Storm Cord (+\$91) I Interlink Cord (+\$55) H Hardwire Cord (+\$106) Q Coiled Cord</p>	<p>3rd Option: Color Option (if applicable): SNW Snow STRM Storm BLK Black DWT White DGY Gray</p>
--	--	---	---

Example: APWRMOD.AC.S.SNW ACPWRMOD.FOG

S Shippable by small-package carrier.

For specification information see page 288.2.

GSA SIN 33721

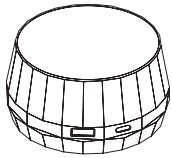

APWRPCK

Description	Model	List Price
Power/Data Module — Clamp On Worksurface		
5"W x 8"D x 4"H	APWRPCK <input type="checkbox"/>	\$ 693
<ul style="list-style-type: none"> • 1 USB-A & 1 USB-C port • 11' straight cord only, no specification needed. • Available in White & Silver only, no specification needed. • <i>Example: APWRPCK</i> 		

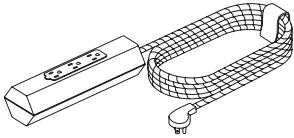

APWRSTRP

Power Strip — Sit-on-Surface, Wood		
4 3/8"W x 1 8/8"D x 4 3/8"H	APWRSTRP <input type="checkbox"/>	\$ 795
<ul style="list-style-type: none"> • 3 receptacles • 10' Braided cord in white nylon only, leather cord management strap included, no specification needed. • Available in wood finish only, no specification needed. • <i>Example: APWRSTRP</i> 		

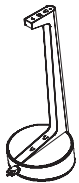

AVSTA3PWR

Vesta Mobile Power		
6 1/2"W x 10"D x 8"H	AVSTA3PWR <input type="checkbox"/>	\$ 2000
<ul style="list-style-type: none"> • 3 receptacles, 1 dual USB-A, 1 USB-C • 10' Straight retractable cord only, no specification needed. • Available in Snow, Storm, Black, and Fog. Separate finish options available for outside and inside of unit. • <i>Example: AVSTA3PWR.STRM.SNW</i> 		

<p>How to specify — Select the Model Number from above.</p>	<p><i>1st Option:</i> Color Option 1 (if applicable):</p> <p>FOG Fog SNW Snow STRM Storm BLK Black</p>	<p><i>2nd Option:</i> Color Option 2 (if applicable):</p> <p>FOG Fog SNW Snow STRM Storm BLK Black</p>
<p>_____ .</p>	<p>_____ .</p>	<p>_____</p>

Example: AVSTA3PWR.STRM.SNW

Shippable by small-package carrier.

For specification information see pages 288.3-288.4.

GSA SIN 33721

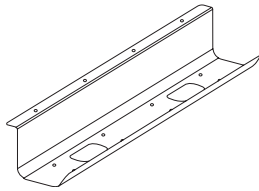

AJTRGH24

Description	Model	List Price		
		P1	P2	P3
Cable Management Trays				
24"W	AJTRGH24 S	\$ 123	N/A	N/A
36"W	AJTRGH36 S	\$ 147	N/A	N/A

- Available in 24" or 36" widths.
- Metal Cable Management Trays available in Black only, specify "P" for finish.
- Example: AJTRGH24.P

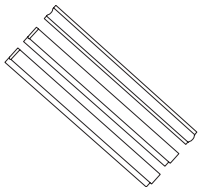

AWRSTRIP

Wire Management Strips/Channels				
	AWRSTRIP S	\$ 270	N/A	N/A

- Four wire management strips/channels in black only, no specification needed.
- Example: AWRSTRIP

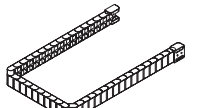

WKSWMC

Wire Management Chains				
36"	A9CLWMC S	\$ 357	N/A	N/A
58"	WKSWMC S	\$ 428	N/A	N/A

- Specify model A9CLWMC for 36" chain, specify model WKSWMC for 58" chain.
- A9CLWMC available in Black (E4), White (DW), or Silver (TI).
- WKSWMC available in Black only, no specification needed.
- Example: A9CLWMC.DW or WKSWMC

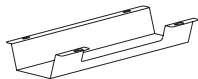

APWRTRGH17

Under Worksurface Troughs				
17"W	APWRTRGH17 S	\$ 108	N/A	N/A
36"W	APWRTRGH36 S	\$ 189	N/A	N/A

- Available in 17" or 36" widths.
- Under Worksurface Troughs available in Black only, no specification needed.
- Example: APWRTRGH17

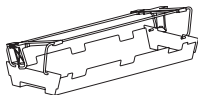

AFDTRGH20

Flip-Down Wire Management Trough				
20"W	AFDTRGH20 S	\$ 378	N/A	N/A
32"W	AFDTRGH32 S	\$ 429	N/A	N/A

- Available in 20" or 32" widths.
- Flip-Down Troughs available in Black only, no specification needed.
- Example: AFDTRGH20



AWIRECLT

Metal Wire Cleat				
	AWIRECLT S	\$ 129	\$ 142	\$ 148

- Available in standard metal paint finishes, see page 240 for options and specify desired finishes.
- Example: AWIRECLT.PJW

<p>How to specify —</p> <p>Select the Model Number from above.</p>	<p><i>1st Option:</i></p> <p>Paint (if applicable): See page 240 for finishes.</p> <p>Plastics (if applicable):</p> <p>DW White TI Silver E4 Black</p>
---	---

Examples: AJTRGH24.P A9CLWMC.DW

S Shippable by small-package carrier.

For specification information see pages 288.3-288.4.

GSA SIN 33721



ALEGCHASE26

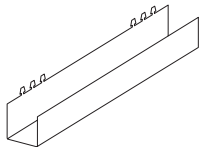

AMPCHASE

Description	Model	List Price		
		P1	P2	P3
O-Leg Chase				
26"H	ALEGCHASE26 S	\$ 174	\$ 191	\$ 200

- O-Leg Chase is 26"H.
- Available in standard metal paint finishes, see page 240 for options and specify desired finishes.
- *Example: ALEGCHASE26.P27*

Panel Mounted Wire Chase				
17"H	AMPCHASE S	\$ 147	\$ 162	\$ 169

- Panel Chase is 17"H.
- Available in standard metal paint finishes, see page 240 for options and specify desired finishes.
- *Example: AMPCHASE.P27*

How to specify —
Select the Model Number from above.

1st Option:
Paint
(if applicable):
See page 240 for finishes.

Plastics
(if applicable):
DW White
TI Silver
E4 Black

Examples: ALEGCHASE26.P27

S Shippable by small-package carrier.

For specification information see pages 288.4-288.5.

GSA SIN 33721

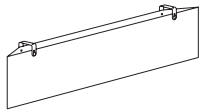

APWRMODEST36

Description	Model	List Price	
		A	B
Fabric Power Modesty			
	APWRMODEST36 <input type="checkbox"/>	\$ 1162	\$ 1196
	APWRMODEST48 <input type="checkbox"/>	\$ 1258	\$ 1297

- Available in ApPOINT, Binary, Centurion, Noble, Reflections, Disperse, and Spin panel fabric series.
- Specify desired fabric.
- Example: APWRMODEST36.NBLE16

How to specify —
Select the Model Number from above.

--	--	--

Example: APWRMODEST36.NBLE16

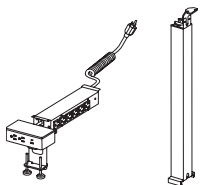

AHATPWRMOD2S or AHATPWRMOD3S

Description	Model	List Price		
		P1	P2	P3
Metal Telescoping HAT Wire Management				
	AHATPWRMOD2S <input type="checkbox"/>	\$ 1614	\$ 1654	\$ 1675
	AHATPWRMOD3S <input type="checkbox"/>	\$ 1646	\$ 1690	\$ 1711

- AHATPWRMOD2S pairs with 2-stage HAT bases.
- AHATPWRMOD3S pairs with 3-stage HAT bases.
- Desktop power module comes with 2 receptacles, 1 USB-A, and 1 USB-C port only, specify “AC” for this power configuration.
- Desktop power module available in White (DWT) or Gray (DGY) finishes, specify desired finish.
- Under worksurface power strip comes with 6 receptacles and is available in Black only, no specification needed.
- Metal Telescoping Chase available in the same paint finishes as Altitude HAT bases, specify desired paint finish.
- Example: AHATPWRMOD2S.AC.DWT.PJW

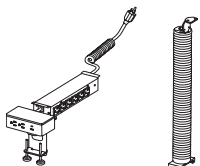

AHATPWRMOD2S or AHATPWRMOD3S

Fabric HAT Wire Management		AHATPWRMODF <input type="checkbox"/>	\$ 1476	\$ 1503	\$ 1516
-----------------------------------	--	--------------------------------------	---------	---------	---------

- AHATPWRMODF pairs with 2-stage and 3-stage HAT bases.
- Desktop power module comes with 2 receptacles, 1 USB-A, and 1 USB-C port only, specify “AC” for this power configuration.
- Desktop power module available in White (DWT) or Gray (DGY) finishes, specify desired finish.
- Under worksurface power strip comes with 6 receptacles and is available in Black only, no specification needed.
- Fabric HAT Chase available in three fabric finishes of Light (LGT), Medium (MDD), and Dark (DRK), specify desired fabric finish.
- Fabric HAT mounting brackets available in the same paint finishes as Altitude HAT bases, specify desired paint finish.
- Example: AHATPWRMODF.AC.DGY.LGT.PR5

How to specify —
Select the Model Number from above.

--	--	--	--

Example: AHATPWRMOD3S.AC.DWT.P8C
AHATPWRMODF.AC.DGY.LGT.PR5

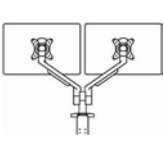
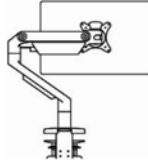
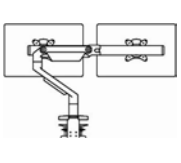
PIVOT MONITOR ARMS	Standard Dynamic Single	Standard Dynamic Dual	Heavy Duty Dynamic Single	Heavy Duty Dynamic Dual with Crossbar
Allsteel Model:	AMASTS	AMASD	AMASHD	AMADHD
				
Features:				
Price	\$488	\$983	\$838	\$1160
Colors	Black and Silver	Black and Silver	Black and Silver	Black and Silver
Monitor Rotation	180°	180°	180°	180°
Monitor Extension	18.75"	18.26"	20.75"	23"
Monitor Tilt Adjustment	+25°/-25°	+25°/-25°	+25°/-25°	+25°/-25°
Arm Height Adjustment	8.4" to 19"	9.6" to 20.1"	8.5" to 20"	8.5" to 20"
Weight Capacity	6.2 to 17 lbs.	6.2 to 17 lbs. per Arm	8 to 35 lbs.	17.5 lbs. per VESA Plate
Mounting Option	Grommet and Clamp Mounts	Grommet and Clamp Mounts	Grommet and Clamp Mounts	Grommet and Clamp Mounts
360° Lockout Feature	Yes	Yes	Yes	Yes
VESA Compatibility	75mm and 100mm	75mm and 100mm	75mm and 100mm	75mm and 100mm
Pole Height	N/A	N/A	N/A	N/A
Maximum Width per Monitor*	N/A	25"	N/A	25"
Worksurface Clamp Requirements	¾" to 2" Thick	¾" to 2" Thick	¾" to 2" Thick	¾" to 2" Thick
Worksurface Grommet Clamp Requirements	¾" to 2" Thick/Hole Diameter ⅜" to 2"	¾" to 2" Thick/Hole Diameter ⅜" to 2"	¾" to 2" Thick/Hole Diameter ⅜" to 2"	¾" to 2" Thick/Hole Diameter ⅜" to 2"
Environmental Info	94% Recycled Content	94% Recycled Content	94% Recycled Content	94% Recycled Content

*Use of APACSM Slider Model will allow for wider monitor capabilities

Pivot Standard Weight Monitor Arms

- Adaptable and adjustable to user preference the Pivot monitor arm offers a slim and refined design coupled with easy fingertip adjustment.
- Multiple points of adjustment including 360 degree swivel with optional 180 degree lockout, 18.75" extension, and 10" of height adjustment.
- Monitor tilts +25/-25 degrees.
- Standard weight arms utilize a tension spring that allows for effortless adjustment of monitors to proper ergonomic positions.
- Tension adjustment at multiple points allows for proper adjustment for monitors weight between 6-17 lbs.
- Model includes grommet and worksurface mounting options.
- Desk clamp mounts require ¾" –2" thick surfaces; grommet mount requires hole diameter of ⅜" to 2" wide and accommodates up to 2" thick surfaces.
- Integrated cable management included with each model. Black models ship with all black cable management pieces, Silver models ship with grey wire management but optional white pieces ship in the box and can be installed on site.
- Dual monitor arm supports up to 25" wide monitors. Wider monitors may require use of optional slider mount model.
- Pivot arms are VESA 75mm and 100mm compatible.
- Quick release feature simplifies monitor installation and changes.

Pivot Slider Mount

- Provides 11.8" of horizontal movement.
- Allows for wider monitors to be used on dual monitor arms and sit flush side by side.
- Not compatible with Pivot Heavy Duty Series.

Pivot Heavy Duty Series

- Adaptable and adjustable to user preference the Pivot monitor arm offers a slim and refined design coupled with easy fingertip adjustment.
- Multiple points of adjustment including 360 degree swivel with optional 180 degree lockout, 20.75" extension, and 12" of height adjustment.
- Monitor tilts +25/-25 degrees.
- Tension adjustment at multiple points allows for proper adjustment for monitors weight between 8-35 lbs.
- Model includes grommet and worksurface mounting options.
- Desk clamp mounts require ¾" –2" thick surfaces; grommet mount requires hole diameter of ⅜" to 2" wide and accommodates up to 2" thick surfaces.
- Integrated cable management included with each model. Black models ship with all black cable management pieces, Silver models ship with grey wire management but optional white pieces ship in the box and can be installed on site.
- Dual monitor arm supports up to 2 monitors weight 4-17.5 lbs each.
- Pivot arms are VESA 75mm and 100mm compatible.
- Quick release feature simplifies monitor installation and changes.

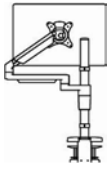
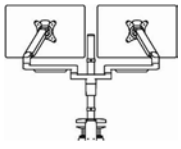
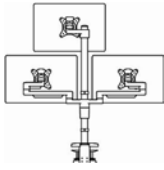
PIVOT MONITOR ARMS	Dynamic Single Post	Dynamic Dual Post	Triple Fixed Post
Allsteel Model:	APASD	APADD	APATF
			
Features:			
Price	\$660	\$923	\$1166
Colors	Silver	Silver	Silver
Monitor Rotation	180°	180°	180°
Monitor Extension	21"	21"	23"
Monitor Tilt Adjustment	+25°/-25°	+25°/-25°	+25°/-25°
Arm Height Adjustment	10.6"	10.6"	N/A
Weight Capacity	6.2 to 17 lbs.	6.2 to 17 lbs. per Arm	17 lbs. per arm
Mounting Option	Grommet and Clamp Mounts	Grommet and Clamp Mounts	Grommet and Clamp Mounts
360° Lockout Feature	Yes	Yes	Yes
VESA Compatibility	75mm and 100mm	75mm and 100mm	75mm and 100mm
Pole Height	17.7"	17.7"	27.5"
Maximum Width per Monitor*	25"	25"	25"
Worksurface Clamp Requirements	7/8" to 2" Thick	7/8" to 2" Thick	7/8" to 2" Thick
Worksurface Grommet Clamp Requirements	7/8" to 2" Thick/Hole Diameter 3/16" to 2"	7/8" to 2" Thick/Hole Diameter 3/16" to 2"	7/8" to 2" Thick/Hole Diameter 3/16" to 2"
Environmental Info	94% Recycled Content	94% Recycled Content	94% Recycled Content

*Use of APACSM Slider Model will allow for wider monitor capabilities

Pivot Post Series

- Adaptable and adjustable to user preference the Pivot monitor arm offers a slim and refined design coupled with easy fingertip adjustment.
- Multiple points of adjustment including 360 degree swivel with 21" extension and 10.6" of height adjustment.
- Monitor tilts +25/-25 degrees.
- Tension adjustment at multiple points allows for proper adjustment for monitors weight between 6.5-17 lbs per arm.
- Model includes grommet and worksurface mounting options.
- Desk clamp mounts require 7/8" – 2" thick surfaces; grommet mount requires hole diameter of 3/16" to 2" wide and accommodates up to 2" thick surfaces.
- Integrated cable management included with each model. Silver color option with grey wire management only.
- Dual monitor arm supports up to 25" wide monitors. Wider monitors may require use of optional slider mount model.
- Single and dual models have a post height of 17.7"; Triple monitor model has a post height of 27.5".
- Pivot arms are VESA 75mm and 100mm compatible.
- Quick release feature simplifies monitor installation and changes.

Pivot Counterweight Kit

- Counterweight Kit to be used with monitors weighing less than 6 lbs.
- Gray color only.
- Counterweight weighs 1 lb. 6 oz.

Pivot Conversion Kits



- Kit allows user to transform single monitor arm (Standard, Heavy Duty, or Post) into Dual Arm configuration
- Available in black and silver, Post arm only available in silver
- Required wire management included
- Once assembled, will aesthetically emulate dual configuration of chosen arm

Accessories — Pivot Monitor Arms

Pivot

For specification information see pages 298-299.

GSA SIN PENDING, GSA SIN 33721

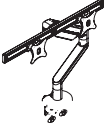
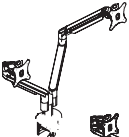
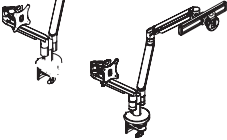
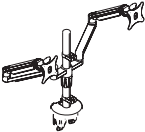
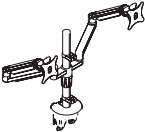
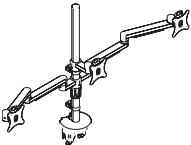
Description	Model	List Price
Pivot Monitor Arms		
 Dynamic Single Monitor - Standard Weight	AMASTS S	\$ 488
Dynamic Single Monitor - Standard Weight for GSA *Silver Only Open for order Fall 2020 – GSA SIN 33721.	AMASTS-G	\$ 576
 Dynamic Single Monitor - Heavy Weight	AMASHD S	\$ 838
 Dynamic Dual Monitor with Crossbar	AMADHD S	\$ 1160
 Dynamic Dual Monitor - Standard Weight	AMASD S	\$ 983
 Dynamic Dual Monitor - Standard Weight for GSA *Silver Only **Slider Mount included. Open for order Fall 2020 – GSA SIN 33721.	AMASD-G	\$ 1048
 Single Dynamic Post Arm *Silver Only	APASD S	\$ 660
 Double Dynamic Post Arm *Silver Only	APADD S	\$ 923
 Triple Fixed Post Mount *Silver Only	APATF S	\$ 1166

How to specify —
Select the
Model Number
from above.

1st Option:
Select the Color:
SVR Silver
BLK Black

A | | | | | | | | | | .

| | | | |

Example: AMADHD.BLK

S Shippable by small-package carrier.

Accessories — Pivot Monitor Arms

Pivot

For specification information see pages 298-299.

Open Market

ACCESSORIES



Description	Model	List Price
Pivot Monitor Arms		
Monitor Arm Sliding Mount	APACSM <input type="checkbox"/>	\$ 233

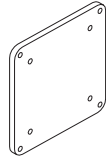

Monitor Arm Counterweight	APACW <input type="checkbox"/>	\$ 55
---------------------------	--------------------------------	-------

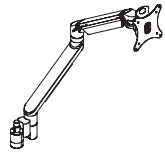

Pivot Monitor Arm Standard Single Conversion Kit	AMASTSCK	\$ 546
--	----------	--------

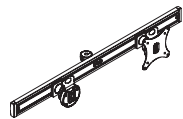

Pivot Monitor Arm Heavy Duty Single Conversion Kit	AMASHDCK	\$ 477
--	----------	--------

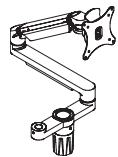

Pivot Single Post Arm Conversion Kit	APASDCK	\$ 695
* Silver Only		

How to specify —
Select the Model Number from above.

1st Option:
Select the Color:
SVR Silver
BLK Black

A | | | | | .

| | | |

Example:

Laterals, Pedestals and Storage, Painted Wood Storage

Standard Options

- Random Keying — The factory will assign key(s) arbitrarily using key numbers from chart below.
- Omit Lock Core — The factory will omit lock cores. Removable lock core kits with specific key number must be ordered to facilitate keying alike in the field.

Vertical Files

Standard Options

- Random Keying — The factory will assign key(s) arbitrarily (see below chart for key numbers).

Key Alike Process







- Order standard product which will be shipped with factory installed locks and random numbered cores.
- Order the appropriate quantity of like numbered cores required for each workstation or keyed area.
- Simply replace the factory installed core with the replacement cores after product has been installed.

Replacing Lock Cores

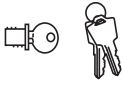
- Lock must be in the unlocked position.
- Insert core removal key and pull core straight out. (Reach units require rotating key 90° clockwise past unlocked position.)
- Insert new core with core removable key, hold core into lock and withdraw core removal key.
- Retain original core for future use.





	Random Keying	Omit Lock Core	Key Numbers	Lock Core Kit	Master Key
Align™ Laterals	X	X	101E-225E	ALKF23C*	AMKF22
Align New Low Credenzas, Towers, Pedestals (“YP” prefix models)	X	X	101E-225E	ALKF26EL	AMKF22
Align Old Pedestals (for New Pedestals after 11/2015 see above)	X	X	101E-225E	ALKF23C*	AMKF22
Align Old Towers (for New Towers after 2/2016 see above)	X	X	101E-225E	ALKF23C*	AMKF22
Align Metal Front Lockers	X	X	101E-225E	ALKF26EL	AMKF22
Align Laminate Front Lockers	X	X	101E-225E	ALKF23C*	AMKF22
Approach™ Desking and Storage	X	X	101E-225E	ALKF26EL	AMKF22
Center Drawer (CSDC19/25)	X	X	101E-225E	ALKF23C*	AMKF22
Essentials™ Laterals	X	X	101E-225E	ALKF23C	AMKF22
Essentials Overfile Cabinets	X	X	101E-225E	ALKF23C*	AMKF22
Essentials Pedestals	X	X	101E-225E	ALKF23C*	AMKF22
Essentials Personal Tower and Files	X	X	101E-225E	ALKF23C*	AMKF22
Further™ Laminate Storage	X	X	101E-225E	ALKF23C*	AMKF22
Hutches	X	X	101E-225E	ALKF23C*	AMKF22
Involve® Laminate Storage	X	X	101E-225E	ALKF23C*	AMKF22
Overheads (Flipper Door, including RTA)	X	X	101E-225E	ALKF23C*	AMKF22
Overheads (Receding Door)	X	X	101E-225E	ALKF23C*	AMKF22
Stride® Painted Wood Storage	X	X	101E-225E	ALKF23C*	AMKF22
Vertical Files A990/A940	X		101E-225E	ALKF23C*	AMKF22

*ALKF23C is chrome. Optional black core for wood casegoods is ALKF23CE4. Optional matte silver core is ALKF26EL.

	Description	Model	List Price
	Removable Lock Core Kits**	Key Numbers 101E-225E	
	Brushed Chrome used on metal and painted wood casegoods product produced after 2/3/97; A980, A990, and A940 Series vertical files; Persona™ pedestals produced after 8/22/09; Reach® Storage units produced after 10/5/09; and receding door overheads produced after 8/1/10. Includes one core, two keys, one core removal tool, adapter and instructions	ALKF23C*** 	\$ 30
	Black used on veneer casegoods product. Includes one core, two keys, one core removal tool, adapter and instructions. Core matches manufactured lock on metal casegoods but Black core can be used with veneer and laminate product.	ALKF23CE4*** 	\$ 30
	Matte Silver used on Approach and Align metal credenzas, new pedestals, and new towers. Includes one core, two keys, one core removal tool, adapter, and instructions.	ALKF26EL*** 	\$ 30
 Open Market	Master Key (One key) Available to authorized dealers only on faxed orders. Will open ALKF23C, LKF23C, ALKF23CE4, LKF23CE4, LKF24, LKF25EL, and LKF25E4 locks numbered 101E-225E.	AMKF22 	\$ 31

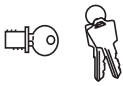
HOW TO ORDER:
Note: Numbers 101E-225E are available. Orders without numbers specified will be keyed at random.
SAMPLE ORDER:

Quantity	Model	Color
6	ALKF23C	X121E
1	AMKF22	X

	Brushed Chrome Removable Lock Core Kit* **	Key Numbers 101N-225N	
	Includes one core, two keys, one core removal tool, adapter, and instructions	ALKF23CN*** 	\$ 30
 Open Market	Master Key* (One key) Available to authorized dealers only on electronic orders. Will open ALKF23CN and LKF23CN locks numbered 101N-225N.	AMF22 	\$ 31

N series lock cores (ALKF23CN) are a replacement part for legacy Allsteel products. N series lock cores were used in all Persona pedestals produced between January 1996 and August 2009 as well as Receding Door Overheads produced between January 1996 and August 2010. N series lock cores are NOT used in current product and should not be ordered for product produced after these dates. E series lock cores are used in current product, see above.

***On existing Premium and Asset lateral, use N-Series locks.**

** Removable Lock Core Kits are intended for use with Allsteel systems furniture and are approved under GSA SIN 33721. When purchased separately and used without Allsteel systems furniture, those Removable Lock Core Kits marked by (**) are considered Open Market.

*** When purchased separately without a configurable TAA compliant end product, not on GSA contract.

EASY LOCK PROGRAM

The Allsteel Easy Lock Program simplifies the lock-core ordering process when multiple cores are being specified. The Easy Lock cores can be used with Allsteel storage that currently uses the **ALKF23C** cores (all storage except Receding Door Overheads).

To ensure ease of ordering in different situations the Easy Lock cores can be specified in three different ways — Random, Specified or Sequential.

Random Keying

The Random Keying option is provided for instances where there are multiple orders or phases to a project and the offices need to be keyed alike but the key numbering is not required. With the random keying option key numbers are not specified, however, the core kits will be in sequential order from a random starting point.

Example: There are 15 offices which each have 5 black locks that need to be keyed alike, but the actual key numbers are not important.

This order would look like: **LKFE5BLK.X.15**

This specifies that 15 5-core kits are needed in black with random key numbers.

Specified Keying

The Specified Keying option is provided for the instances where there is a specific key number desired for all of the cores ordered.

Example: There are 10 offices which each have 2 silver locks that need to be keyed-alike with key number 202.

This order would look like: **LKFE2SLV.X202.10**

This specifies that 10 2-core kits are needed in silver with key number 202.

Sequential Keying

Allsteel Sequential Keying option is provided for the instances when there are multiple orders or phases to a project and it is imperative that key numbers are not duplicated.

Example: A multiple phase project has 60 total offices — 40 offices in Phase I, and 20 offices in Phase II. The project manager has expressed a need to have keyed-alike offices but doesn't want any of the offices to use the same key numbers.

The first 40 offices have 4 silver locks each that need to be keyed-alike.

This order would look like: **LKFE4SLV.SEQ/101.40**

This specifies that 40 4-core kits are needed in silver and the starting number is 101.

The second set of 20 offices only have 3 silver locks each that need to be keyed-alike; and it is important which key number starts off the sequence to ensure that no key number is duplicated. It is known that the first key range was key numbers 101-140.

The second order would look like: **LKFE3SLV.SEQ/141.20**

This specifies that 20 3-core kits are needed in silver and key sequence has to start at key number 141.

HOW TO ORDER:

Numbers 101-225 are available. Orders without key numbers specified will be keyed at random.

SAMPLE ORDER FOR EXAMPLES GIVEN:

Model	Key Type	Quantity
LKFE5BLK.	X.	15
LKFE2SLV.	X202.	10
LKFE4SLV.	SEQ/101.	40
LKFE3SLV.	SEQ/141.	20

NOTE: Quantity required is last number in model.option string.

Description	Model / Color	List Price
Easy Lock Lock-Core		
Lock Core Kit — 1 core, 2 keys	LKFE1 _____	\$ 30
Lock Core Kit — 2 cores, 2 keys	LKFE2 _____	\$ 61
Lock Core Kit — 3 cores, 2 keys	LKFE3 _____	\$ 91
Lock Core Kit — 4 cores, 2 keys	LKFE4 _____	\$ 121
Lock Core Kit — 5 cores, 2 keys	LKFE5 _____	\$ 151
Add color suffix to model: SLV Silver, BLK Black, MTS Matte Silver		
Note: One core removal key minimum per order. One additional core removal key per 25 lock-cores will be shipped.		
Note: When purchased separately without a configurable TAA compliant end product, not on GSA contract.		
Master Key		
(One key) Available to authorized dealers only on faxed orders.		
	AMKF22	\$ 31

How to specify using Easy Lock Program:

Step 1 — Count the number of lock cores and color required in each workstation that need to be keyed alike.

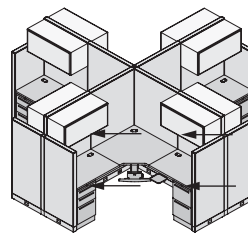

2 overheads with 1 lock-core each = 2
 2 pedestals with 1 lock-core each = 2
Total silver lock-cores per station = 4

Step 2 — Count the total number of workstations needing 4 lock-cores.

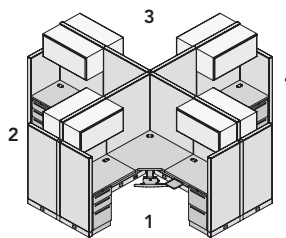

4 total workstations

Step 3 — Specify model number based on total number of lock-cores in a station and quantity of kits based on number of workstations.

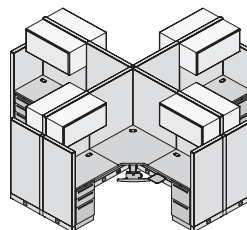

LKFE4SLV.X.4

Lock-Cores per station

Color of Core

Number of workstations

Description	Model	P1 List Price	P2 List Price	P3 List Price
Touch-Up Paint — Brush				
Bottle of Touch-Up Paint with Brush — 0.5 oz.	APTK S	\$ 102	\$ 114	\$ 122
Touch-Up Paint — Spray				
Spray Can of Touch-Up Paint — 12 oz.	ARSLCC S	\$ 102	\$ 114	\$ 122

<p><i>How to specify —</i> Select the Model Number from above.</p>	<p><i>1st Option:</i> Paint Color: P1 P2 P3</p> <p>See page 12 for options. Available touch-up paint colors listed above. Carbon Metallic is limited to spray.</p>
--	---

A | | | | | | | .

| | | | | | |

Examples: APTK.P02 ARSLCC.P02

S Shippable by small-package carrier.

Model Number	Description	Grade G	Grade H	Grade J
Optimize® Tackable Panels — see page 76				
P13524TP	24"W	\$ 996	\$ 1076	\$ 1158
P13530TP	30"W	\$ 1079	\$ 1164	\$ 1251
P13536TP	36"W	\$ 1202	\$ 1300	\$ 1399
P13542TP	42"W	\$ 1236	\$ 1336	\$ 1435
P13548TP	48"W	\$ 1329	\$ 1437	\$ 1545
P13560TP	60"W	\$ 1514	\$ 1639	\$ 1766
P13572TP	72"W	\$ 1896	\$ 2053	\$ 2210
<hr/>				
P14224TP	24"W	\$ 1050	\$ 1136	\$ 1222
P14230TP	30"W	\$ 1170	\$ 1266	\$ 1363
P14236TP	36"W	\$ 1308	\$ 1415	\$ 1519
P14242TP	42"W	\$ 1433	\$ 1549	\$ 1667
P14248TP	48"W	\$ 1537	\$ 1662	\$ 1788
P14260TP	60"W	\$ 1798	\$ 1946	\$ 2094
P14272TP	72"W	\$ 2059	\$ 2227	\$ 2395
<hr/>				
P15024TP	24"W	\$ 1150	\$ 1245	\$ 1342
P15030TP	30"W	\$ 1281	\$ 1383	\$ 1487
P15036TP	36"W	\$ 1445	\$ 1565	\$ 1682
P15042TP	42"W	\$ 1603	\$ 1733	\$ 1861
P15048TP	48"W	\$ 1731	\$ 1871	\$ 2009
P15060TP	60"W	\$ 1912	\$ 2066	\$ 2222
P15072TP	72"W	\$ 2310	\$ 2496	\$ 2684
<hr/>				
P16524TP	24"W	\$ 1249	\$ 1349	\$ 1448
P16530TP	30"W	\$ 1417	\$ 1531	\$ 1645
P16536TP	36"W	\$ 1583	\$ 1707	\$ 1835
P16542TP	42"W	\$ 1757	\$ 1898	\$ 2038
P16548TP	48"W	\$ 1860	\$ 2009	\$ 2158
P16560TP	60"W	\$ 2069	\$ 2238	\$ 2408
P16572TP	72"W	\$ 2529	\$ 2734	\$ 2938
<hr/>				
P21524T	24"W	\$ 703	\$ 785	\$ 867
P21530T	30"W	\$ 777	\$ 866	\$ 957
P21536T	36"W	\$ 860	\$ 959	\$ 1055
P21542T	42"W	\$ 932	\$ 1039	\$ 1146
P21548T	48"W	\$ 1001	\$ 1115	\$ 1229
P21560T	60"W	\$ 1364	\$ 1518	\$ 1674
P21572T	72"W	\$ 1448	\$ 1615	\$ 1780

Model Number	Description	Grade G	Grade H	Grade J
Optimize® Glazed Panels — see page 78				
P15024HP	24"W Clear Glass	\$ 1906	\$ 2058	\$ 2212
P15030HP	30"W Clear Glass	\$ 2079	\$ 2244	\$ 2409
P15036HP	36"W Clear Glass	\$ 2271	\$ 2452	\$ 2634
P15042HP	42"W Clear Glass	\$ 2481	\$ 2678	\$ 2875
P15048HP	48"W Clear Glass	\$ 2592	\$ 2802	\$ 3011
P15060HP	60"W Clear Glass	\$ 2984	\$ 3225	\$ 3465
P15072HP	72"W Clear Glass	\$ 3617	\$ 3906	\$ 4196
<hr/>				
P15024HP	24"W Frosted Glass	\$ 1983	\$ 2135	\$ 2289
P15030HP	30"W Frosted Glass	\$ 2161	\$ 2326	\$ 2491
P15036HP	36"W Frosted Glass	\$ 2360	\$ 2541	\$ 2723
P15042HP	42"W Frosted Glass	\$ 2576	\$ 2773	\$ 2970
P15048HP	48"W Frosted Glass	\$ 2694	\$ 2904	\$ 3113
P15060HP	60"W Frosted Glass	\$ 3103	\$ 3344	\$ 3584
P15072HP	72"W Frosted Glass	\$ 3761	\$ 4050	\$ 4340
<hr/>				
P16524HP	24"W Clear Glass	\$ 2081	\$ 2246	\$ 2411
P16530HP	30"W Clear Glass	\$ 2249	\$ 2430	\$ 2610
P16536HP	36"W Clear Glass	\$ 2467	\$ 2664	\$ 2860
P16542HP	42"W Clear Glass	\$ 2689	\$ 2903	\$ 3116
P16548HP	48"W Clear Glass	\$ 2820	\$ 3046	\$ 3273
P16560HP	60"W Clear Glass	\$ 3265	\$ 3528	\$ 3793
P16572HP	72"W Clear Glass	\$ 3942	\$ 4257	\$ 4573
<hr/>				
P16524HP	24"W Frosted Glass	\$ 2163	\$ 2328	\$ 2493
P16530HP	30"W Frosted Glass	\$ 2338	\$ 2519	\$ 2699
P16536HP	36"W Frosted Glass	\$ 2562	\$ 2759	\$ 2955
P16542HP	42"W Frosted Glass	\$ 2794	\$ 3008	\$ 3221
P16548HP	48"W Frosted Glass	\$ 2931	\$ 3157	\$ 3384
P16560HP	60"W Frosted Glass	\$ 3393	\$ 3656	\$ 3921
P16572HP	72"W Frosted Glass	\$ 4098	\$ 4413	\$ 4729
<hr/>				
Optimize® Tackboards for Stack-on Hutches — see page 129				
UHTB36	36"W	\$ 1024	\$ 1024	\$ 1313
UHTB42	42"W	\$ 1073	\$ 1073	\$ 1375
UHTB48	48"W	\$ 1190	\$ 1190	\$ 1534
UHTB60	60"W	\$ 1412	\$ 1412	\$ 1845
UHTB66	66"W	\$ 1516	\$ 1516	\$ 1987
UHTB72	72"W	\$ 1547	\$ 1547	\$ 2015

Model Number	Description	Grade G	Grade H	Grade J
Consensys® Tackboards and Cord Covers — see page 229				
861324	24"W	\$ 395	\$ 395	\$ 503
861330	30"W	\$ 447	\$ 447	\$ 559
861336	36"W	\$ 518	\$ 518	\$ 654
861342	42"W	\$ 597	\$ 597	\$ 757
861348	48"W	\$ 669	\$ 669	\$ 853
861360	60"W	\$ 763	\$ 763	\$ 979
<hr/>				
861824	24"W	\$ 433	\$ 433	\$ 560
861830	30"W	\$ 537	\$ 537	\$ 697
861836	36"W	\$ 618	\$ 618	\$ 805
861842	42"W	\$ 715	\$ 715	\$ 936
861848	48"W	\$ 804	\$ 804	\$ 1057
861860	60"W	\$ 899	\$ 899	\$ 1185
<hr/>				
EL97	13"H	\$ 103	\$ 103	\$ 111
EL99	18"H	\$ 103	\$ 103	\$ 111

Consensys® Universal Tackboards for Stack-on Hitches — see page 230				
UHTB36	36"W	\$ 1024	\$ 1024	\$ 1313
UHTB42	42"W	\$ 1073	\$ 1073	\$ 1375
UHTB48	48"W	\$ 1190	\$ 1190	\$ 1534
UHTB60	60"W	\$ 1412	\$ 1412	\$ 1845
UHTB66	66"W	\$ 1516	\$ 1516	\$ 1987
UHTB72	72"W	\$ 1547	\$ 1547	\$ 2015

Altitude® A8 Screen Kits — see page 275				
FDSC48U	48"W	\$ 2257	\$ 2282	\$ 2344
FDSC54U	54"W	\$ 2335	\$ 2361	\$ 2426
FDSC60U	60"W	\$ 2405	\$ 2431	\$ 2497
FDSC66U	66"W	\$ 2547	\$ 2575	\$ 2647
FDSC72U	72"W	\$ 2742	\$ 2771	\$ 2849
<hr/>				
FDSC48LL	48"W	\$ 1453	\$ 1468	\$ 1504
FDSC48LR	48"W	\$ 1453	\$ 1468	\$ 1504
FDSC54LL	54"W	\$ 1706	\$ 1724	\$ 1767
FDSC54LR	54"W	\$ 1706	\$ 1724	\$ 1767
FDSC60LL	60"W	\$ 1785	\$ 1803	\$ 1849
FDSC60LR	60"W	\$ 1785	\$ 1803	\$ 1849
FDSC66LL	66"W	\$ 2140	\$ 2163	\$ 2223
FDSC66LR	66"W	\$ 2140	\$ 2163	\$ 2223
FDSC72LL	72"W	\$ 2254	\$ 2280	\$ 2342
FDSC72LR	72"W	\$ 2254	\$ 2280	\$ 2342
<hr/>				
FDSC48R	48"W	\$ 1404	\$ 1420	\$ 1454
FDSC54R	54"W	\$ 1439	\$ 1454	\$ 1490
FDSC60R	60"W	\$ 1549	\$ 1564	\$ 1602
FDSC66R	66"W	\$ 1791	\$ 1811	\$ 1860
FDSC72R	72"W	\$ 1908	\$ 1929	\$ 1980

Cross Reference Index

by Model Number

Model	Page	Model	Page	Model	Page	Model	Page	Model	Page
9120 Program	118, 119, 217, 218	A870830CH	295	A871918A	64, 93, 190, 273	AF5RND9630D	268	AMASHDCK	301
801550	220	A870842CH	295	A871972	64, 93, 273, 271	AF5RS3624U	269	AMASTS	300
802424M	116, 215	A870860	295	A871972A	64, 93, 273, 271	AF5RS3630U	269	AMASTSCK	301
803030M	116, 215	A870860CH	295	A873501	273	AF5RS4224U	269	AMASTS-G	300
830299	220	A871024	92, 189	A873502	273	AF5RS4230U	269	AMF22	303
831099	219	A871024A	92, 189	A873503	273	AF5RS4824	268	AMKF22	303, 304
831124	121, 219, 220	A871030	92, 189	A873504	273	AF5RS4824U	269	AMPCHASE	94, 297.3
831130	121, 219, 220	A871030A	92, 189	A873506	273	AF5RS4830	268	AMRK36	77
831212M	112, 211	A871036	92, 189	A876072	273	AF5RS4830U	269	AMRK42	77
831324	219	A871036A	92, 189	A876072A	273	AF5RS5424	268	AMRK48	77
831330	219	A871042	92, 189	A877012	64, 273	AF5RS5424U	269	AMS2048LH	276
832407M	116, 215	A871042A	92, 189	A877101	63	AF5RS5430	268	AMS2048RH	276
833007M	116, 215	A871048	92, 189	A877501	64	AF5RS5430U	269	AMS2048SS	277
851524M	54, 117, 175, 216	A871048A	92, 189	A877501A	64	AF5RS6024D	268	AMS2048U	276
851530M	54, 117, 175, 216	A871060	63, 92, 189	A877502A	64	AF5RS6024UD	269	AMS2054LH	276
851536M	54, 117, 175, 216	A871060A	63, 92, 189	A877503	64	AF5RS6030D	268	AMS2054RH	276
851542M	54, 117, 175, 216	A871066	63	A877503A	64	AF5RS6030UD	269	AMS2054SS	277
851548M	54, 117, 175, 216	A871066A	63	A877504	64	AF5RS6624D	268	AMS2054U	276
851554M	54, 117, 175, 216	A871072	63	A877506	64	AF5RS6624UD	269	AMS2060LH	276
851560M	54, 117, 175, 216	A871072A	63	A877507	93, 190	AF5RS6630D	268	AMS2060RH	276
851566M	54, 117, 175, 216	A871078	63	A879072A	93, 190	AF5RS6630UD	269	AMS2060SS	277
851572M	54, 117, 175, 216	A871078A	63	A879168	93, 190	AF5RS7224D	268	AMS2060U	276
852424M	54, 117, 175, 216	A871084	63	A879168A	93, 190	AF5RS7224UD	269	AMS2066LH	276
853030M	54, 117, 175, 216	A871084A	63	AABPWRMOD	271.2, 297	AF5RS7230D	268	AMS2066RH	276
853636M	54, 117, 175, 216	A871124	92, 189, 272	AAPAC	291.1	AF5RS7230UD	269	AMS2066SS	277
854242M	54, 117, 175, 216	A871124A	92, 189, 272	AAPACM2	94, 191, 295	AF5RS7824D	268	AMS2066U	276
860536M	113, 212	A871130	63, 92, 189	AAPAH	291.1	AF5RS7824UD	269	AMS2072LH	276
860542M	113, 212	A871130A	63, 92, 189	AAPAHF	291.1	AF5RS7830D	268	AMS2072RH	276
860548M	113, 212	A871136	92, 189	AAPAMF	291.1	AF5RS7830UD	269	AMS2072SS	277
861324	229	A871136A	92, 189	AAPASB	291.1	AF5RS8424D	268	AMS2072U	276
861330	229	A871142	92, 189	AAPASH	291.1	AF5RS8424UD	269	AMS3248LH	276
861336	229	A871142A	92, 189	AAPAST	291.1	AF5RS8430D	268	AMS3248RH	276
861342	229	A871148	92, 189, 272	AAS1520	277	AF5RS8430UD	269	AMS3248SS	277
861348	229	A871148A	92, 189, 272	AAS1548	277	AF5RS9024D	268	AMS3248U	276
861360	229	A871160	63, 92, 189, 272	AAS1554	277	AF5RS9024UD	269	AMS3254LH	276
861824	229	A871160A	63, 92, 189, 272	AAS1572	277	AF5RS9030D	268	AMS3254RH	276
861830	229	A871166	63	ABKCL	282	AF5RS9030UD	269	AMS3254SS	277
861836	229	A871166A	63	ABKCR	282	AF5RS9624D	268	AMS3254U	276
861842	229	A871172	63, 92, 189, 272	ABKTL	282	AF5RS9624UD	269	AMS3260LH	276
861848	229	A871172A	63, 92, 189, 272	ABKTR	282	AF5RS9630D	268	AMS3260RH	276
861860	229	A871178	63	ACBH	219	AF5RS9630UD	269	AMS3260SS	277
873600	274	A871178A	63	ACBHEP1229	219	AF5120S4224D	269	AMS3260U	276
877600	65	A871184	63	ACBHEP2429	219	AF5120S4230D	269	AMS3266LH	276
899900	79	A871184A	63	ACBHEP3029	219	AF5120S4824D	269	AMS3266RH	276
899910	79	A871224	92, 189	ACD1	292	AF5120S4830D	269	AMS3266SS	277
A2-8CIR24	92, 189	A871224A	92, 189	ACPU1	286	AF5120S5424D	269	AMS3266U	276
A2-8CIR30	92, 189	A871230	63, 92, 189	ACPWRMOD	297	AF5120S5430D	269	AMS3272LH	276
A2-8CIR36	92, 189	A871230A	63, 92, 189	AECH	277	AFDTRGH20	271, 297.2	AMS3272RH	276
A2-8CIR42	92, 189	A871236	92, 189	AEHF	277	AFDTRGH32	271, 297.2	AMS3272SS	277
A2-8CIR48	92, 189	A871236A	92, 189	AESS	277	AGBKC	53, 175, 282	AMS3272U	276
A2-8CIR60	92, 189	A871242	92, 189	AF5CCS5424	269	AGBKT	53, 175, 282	APACSM	301
A2-8CIR72	92	A871242A	92, 189	AF5CCS5430	269	AGBKTMP	53, 175, 282	APACW	301
A6BLUETOOTH	267	A871248	92, 189, 272	AF5CCS603624LD	270	AGSAUHK	283	APADD	300
A6CASTER	267	A871248A	92, 189, 272	AF5CCS603624RD	270	AHATPWRMOD2S	271.3, 297.4	APASD	300
A6G1GLIDE	267	A871254	272	AF5CCS604824LD	270	AHATPWRMOD3S	271.3, 297.4	APASDCK	301
A6MREC3S2LCF	266	A871254A	272	AF5CCS604824RD	270	AJTRGH24	94, 191, 271, 297.2	APATF	300
A6MREC3S2LTF	266	A871260	63, 92, 189, 272	AF5CCS604830LD	270	AJTRGH36	94, 191, 271, 297.2	APCM6	291
A6MREC3S3LCF	267	A871266	63, 272	AF5CCS723624LD	270	AKMH	286	APTK	305
A6MREC3S3LTF	267	A871266A	63, 272	AF5CCS723624RD	270	AKTLONG	286	APWR4TAP	271.1, 297
A6REC2S2LCF	266	A871272	63, 92, 272	AF5CCS724824LD	270	AKTMID	286	APWRMOD	297
A6REC2S2LTF	266	A871272A	63, 92, 272	AF5CCS724824RD	270	AKTSHORT	286	APWRMODEST36	271.2, 297.4
A6REC2S3LCF	266	A871278	63	AF5CCS724830LD	270	ALED17U	295	APWRMODEST48	271.2, 297.4
A6REC2S3LTF	266	A871284	63	AF5RND4824	268	ALED17U60	295	APWRPCK	297.1
A6REC3S2LCF	266	A871284A	63	AF5RND4830	268	ALED17UJMP30	295	APWRSTRP	297.1
A6REC3S2LTF	266	A871400	64, 93, 190, 273	AF5RND4830D	268	ALED31U	295	APWRTRGH17	271, 297.2
A6REC3S3LCF	267	A871400A	64, 93, 190, 273	AF5RND6024D	268	ALED31U60	295	APWRTRGH36	271, 297.2
A6REC3S3LTF	267	A871500	65, 93, 190	AF5RND6030D	268	ARNDPWRMOD	297	ARSLCC	305
A6SLDGLIDE	267	A871501	64, 93, 190	AF5RND6624D	268	ATADF3	65, 94, 192, 274	ATADF4	65, 94, 192, 274
A9CIWMC	271, 297.2	A871501A	64, 93, 190, 273	AF5RND6630D	268	ATADJ5	65, 94, 192, 274	ATADJ6	65, 94, 192, 274
A5622ELS	270	A871502	64, 93, 190	AF5RND7224D	268	AUPWRMOD	297	AURNDPWRMOD	297
A5622ERS	270	A871502A	64, 93, 190, 273	AF5RND7230D	268	AVF5RS4824	268	AVF5RS4830	268
A5722ELS	270	A871503	64, 93, 190	AF5RND7824D	268	AVF5RS5430	268	AVF5RS5430D	268
A5822ELS	270	A871503A	64, 93, 190, 273	AF5RND8424D	268	AVF5RS6024D	268	AVF5RS6030D	268
A5922ELS	270	A871504	64, 93, 190	AF5RND8430D	268	AVF5RS6624D	268		
A5922ERS	270	A871506	64, 93, 190	AF5RND9024D	268				
A870070	93, 191	A871601	64, 93, 190, 273	AF5RND9030D	268				
A870071	191	A871601A	64, 93, 190, 273	AF5RND9624D	268				
A870824	295	A871912	64, 93, 190, 273						
A870824CH	295	A871912A	64, 93, 190, 273						
A870830	295	A871918A	64, 93, 190, 273						

INDEX

Cross Reference Index

by Model Number

Model	Page	Model	Page	Model	Page	Model	Page	Model	Page
AVF5RS6630D	268	EAPT	291	G3072G	166	G4260	163	G5745G	170
AVF5RS7224D	268	EASR24	290	G3075	161	G4260G	168	G5748	165
AVF5RS7230D	268	EASR30	290	G3075G	166	G4263	163	G5748G	170
AVSTA3PWR	297.1	EASR36	290	G3078	161	G4263G	168	G5751	165
AWCS	286	EASR42	290	G3078G	166	G4266	163	G5751G	170
AWIRECLT	271, 297.2	EASR48	290	G3081	161	G4266G	168	G5754	165
AWRSTRIP	94, 191, 271, 297.2	EASR60	290	G3081G	166	G4269	163	G5754G	170
AYBHEP1229	120	EASS	291	G3084	161	G4269G	168	G5757	165
AYBHEP1829	120	EATS	291	G3084G	166	G4272	163	G5757G	170
AYBHEP2429	120	EL96	229	G3518	162	G4272G	168	G5760	165
AYBHEP3029	120	EL97	229	G3518G	167	G4275	163	G5760G	170
CBK29	121, 220	EL98	229	G3521	162	G4275G	168	G5763	165
CBPLATE3-36	94, 192	EL99	229	G3521G	167	G4278	163	G5763G	170
CBPLATE3-42	94, 192	FDEPC2	278	G3524	162	G4278G	168	G5766	165
CBPLATE3-48	94, 192	FDEPC12	278	G3524G	167	G4281	163	G5766G	170
CBPLATE3-60	94, 192	FDPWRC	271.1	G3527	162	G4281G	168	G5769	165
CCB12L	219	FDPWRSC	271.1	G3527G	167	G4284	163	G5769G	170
CCB12R	219	FDRWEC	278	G3530	162	G4284G	168	G5772	165
CCB18L	219	FDRWLEG	278	G3530G	167	G5018	164	G5772G	170
CCB18R	219	FDRWUC	278	G3533	162	G5018G	169	G5775	165
CCB24L	219	FDS48LL	275	G3533G	167	G5021	164	G5775G	170
CCB24R	219	FDS48LR	275	G3536	162	G5021G	169	G5778	165
CDG	122, 221	FDS48R	275	G3536G	167	G5024	164	G5778G	170
CDL29	121, 220	FDS48U	275	G3539	162	G5024G	169	G5781	165
CEP1129F	121, 220	FDS48U	275	G3539G	167	G5027	164	G5781G	170
CEP1129P	219, 220	FDS54LR	275	G3542	162	G5027G	169	G5784	165
CEP2429F	121, 220	FDS54R	275	G3542G	167	G5030	164	G5784G	170
CEP2429P	219, 220	FDS54U	275	G3545	162	G5030G	169	G40715GS	44, 172
CEP3029F	121, 220	FDS60LL	275	G3545G	167	G5033	164	G40718GS	44, 172
CEP3029P	219, 220	FDS60LR	275	G3548	162	G5033G	169	G40721GS	44, 172
CFDPWRC	271.1	FDS60R	275	G3548G	167	G5036	164	G40724GS	44, 172
CFDPWRSC	271.1	FDS60U	275	G3551	162	G5036G	169	G40727GS	44, 172
COMBKT	228	FDS66LL	275	G3551G	167	G5039	164	G40730GS	44, 172
CPMB29	220	FDS66LR	275	G3554	162	G5039G	169	G40733GS	44, 172
CRK29	121, 220	FDS66R	275	G3554G	167	G5042	164	G40736GS	44, 172
CS244	122, 221	FDS66U	275	G3557	162	G5042G	169	G40739GS	44, 172
CS249	122, 221	FDS66U	275	G3557G	167	G5045	164	G40742GS	44, 172
CS304	122, 221	FDS66U	275	G3560	162	G5045G	169	G40745GS	44, 172
CS309	122, 221	FDS66U	275	G3560G	167	G5048	164	G40748GS	44, 172
CS364	122, 221	FDS66U	275	G3563	162	G5048G	169	G40751GS	44, 172
CS369	122, 221	GIAGF	53, 177	G3563G	167	G5051	164	G40754GS	44, 172
CS424	122, 221	G1PTR	53, 177	G3566	162	G5051G	169	G40757GS	44, 172
CS429	122, 221	G2AGF	53, 177	G3566G	167	G5054	164	G40760GS	44, 172
CS484	122, 221	G2PTR	53, 177	G3569	162	G5054G	169	G40763GS	44, 172
CS489	122, 221	G3AGF	53, 177	G3569G	167	G5057	164	G40766GS	44, 172
CS544	122, 221	G3PTR	53, 177	G3572	162	G5057G	169	G40769GS	44, 172
CS549	122, 221	G3018	161	G3572G	167	G5060	164	G40772GS	44, 172
CS604	122, 221	G3018G	166	G3575	162	G5060G	169	G40775GS	44, 172
CS609	122, 221	G3021	161	G3575G	167	G5063	164	G40778GS	44, 172
CS664	122, 221	G3021G	166	G3578	162	G5063G	169	G40781GS	44, 172
CS669	122, 221	G3024	161	G3578G	167	G5066	164	G40784GS	44, 172
CS724	122, 221	G3024G	166	G3581	162	G5066G	169	G41324GS	45, 173
CS729	122, 221	G3027	161	G3581G	167	G5069	164	G41327GS	45, 173
CSCMP3614	122, 221	G3027G	166	G3584	162	G5069G	169	G41330GS	45, 173
CSCMP3629	122, 221	G3030	161	G3584G	167	G5072	164	G41333GS	45, 173
CSCMP4214	122, 221	G3030G	166	G4218	163	G5072G	169	G41336GS	45, 173
CSCMP4229	122, 221	G3033	161	G4218G	168	G5075	164	G41339GS	45, 173
CSCMP4814	122, 221	G3033G	166	G4221	163	G5075G	169	G41342GS	45, 173
CSCMP4829	122, 221	G3036	161	G4221G	168	G5078	164	G41345GS	45, 173
CSCMP6014	122, 221	G3036G	166	G4224	163	G5078G	169	G41348GS	45, 173
CSCMP6029	122, 221	G3039	161	G4224G	168	G5081	164	G41351GS	45, 173
CSCMP7214	122, 221	G3039G	166	G4227	163	G5081G	169	G41354GS	45, 173
CSCMP7229	122, 221	G3042	161	G4227G	168	G5084	164	G41357GS	45, 173
CSDC19	222, 292	G3042G	166	G4230	163	G5084G	169	G41360GS	45, 173
CSDC25	222, 292	G3045	161	G4230G	168	G5718	165	G41363GS	45, 173
CSL2429F	121, 220	G3045G	166	G4233	163	G5718G	170	G41366GS	45, 173
CSL2429P	219, 220	G3048	161	G4233G	168	G5721	165	G41369GS	45, 173
CSL3029F	121, 220	G3048G	166	G4236	163	G5721G	170	G41372GS	45, 173
CSL3029P	219, 220	G3051	161	G4236G	168	G5724	165	G41375GS	45, 173
EAAC	291	G3051G	166	G4239	163	G5724G	170	G41378GS	45, 173
EABS	291	G3054	161	G4239G	168	G5727	165	G41381GS	45, 173
EACS	291	G3054G	166	G4242	163	G5727G	170	G41384GS	45, 173
EADH	291	G3057	161	G4242G	168	G5730	165	G41515GS	46, 174
EAFS	291	G3057G	166	G4245	163	G5730G	170	G41518GS	46, 174
EAFT	291	G3060	161	G4245G	168	G5733	165	G41521GS	46, 174
EAHSR36	290	G3060G	166	G4248	163	G5733G	170	G41524GS	46, 174
EAHSR42	290	G3063	161	G4248G	168	G5736	165	G41527GS	46, 174
EAHSR48	290	G3063G	166	G4251	163	G5736G	170	G41530GS	46, 174
EAHSR60	290	G3066	161	G4251G	168	G5739	165	G41533GS	46, 174
EAHSR66	290	G3066G	166	G4254	163	G5739G	170	G41536GS	46, 174
EAHSR72	290	G3069	161	G4254G	168	G5742	165	G41539GS	46, 174
EAPS	291	G3069G	166	G4257	163	G5742G	170	G41542GS	46, 174
		G3072	161	G4257G	168	G5745	165	G41545GS	46, 174

INDEX

Cross Reference Index

by Model Number

Model	Page	Model	Page	Model	Page	Model	Page	Model	Page
G41548GS	46, 174	GL3521LG	157	GL4260L	153	GL5727RG	160	GSYS3048G	39
G41551GS	46, 174	GL3521R	152	GL4260LG	158	GL5730L	155	GSYS3054	34
G41554GS	46, 174	GL3521RG	157	GL4260R	153	GL5730LG	160	GSYS3054G	39
G41557GS	46, 174	GL3524L	152	GL4260RG	158	GL5730R	155	GSYS3060	34
G41560GS	46, 174	GL3524LG	157	GL4266L	153	GL5730RG	160	GSYS3060G	39
G41563GS	46, 174	GL3524R	152	GL4266LG	158	GL5736L	155	GSYS3066	34
G41566GS	46, 174	GL3524RG	157	GL4266R	153	GL5736LG	160	GSYS3066G	39
G41569GS	46, 174	GL3527L	152	GL4266RG	158	GL5736R	155	GSYS3072	34
G41572GS	46, 174	GL3527LG	157	GL4272L	153	GL5736RG	160	GSYS3072G	39
G41575GS	46, 174	GL3527R	152	GL4272LG	158	GL5742L	155	GSYS3078	34
G41578GS	46, 174	GL3527RG	157	GL4272R	153	GL5742LG	160	GSYS3078G	39
G41581GS	46, 174	GL3530L	152	GL4272RG	158	GL5742R	155	GSYS3084	34
G41584GS	46	GL3530LG	157	GL4278L	153	GL5742RG	160	GSYS3084G	39
GACRL12	53, 177	GL3530R	152	GL4278LG	158	GL5748L	155	GSYS3518	35
GACRL18	53, 177	GL3530RG	157	GL4278R	153	GL5748LG	160	GSYS3518G	40
GACRL24	53, 177	GL3536L	152	GL4278RG	158	GL5748R	155	GSYS3524	35
GACRL30	53, 177	GL3536LG	157	GL5018L	154	GL5748RG	160	GSYS3524G	40
GACRL36	53, 177	GL3536R	152	GL5018LG	159	GL5754L	155	GSYS3530	35
GBRSF	53, 177	GL3536RG	157	GL5018R	154	GL5754LG	160	GSYS3530G	40
GCHMT	53, 177	GL3542L	152	GL5018RG	159	GL5754R	155	GSYS3536	35
GCHRB	53, 177	GL3542LG	157	GL5021L	154	GL5754RG	160	GSYS3536G	40
GCTKS	54, 175	GL3542R	152	GL5021LG	159	GL5760L	155	GSYS3542	35
GFT1	52, 176	GL3542RG	157	GL5021R	154	GL5760LG	160	GSYS3542G	40
GFT2	176	GL3548L	152	GL5021RG	159	GL5760R	155	GSYS3548	35
GHMB2030	52, 176	GL3548LG	157	GL5024L	154	GL5760RG	160	GSYS3548G	40
GHMB2630	52, 176	GL3548R	152	GL5024LG	159	GL5766L	155	GSYS3554	35
GL3018L	151	GL3548RG	157	GL5024R	154	GL5766LG	160	GSYS3554G	40
GL3018LG	156	GL3554L	152	GL5024RG	159	GL5766R	155	GSYS3560	35
GL3018R	151	GL3554LG	157	GL5027L	154	GL5766RG	160	GSYS3560G	40
GL3018RG	156	GL3554R	152	GL5027LG	159	GL5772L	155	GSYS3566	35
GL3021L	151	GL3554RG	157	GL5027R	154	GL5772LG	160	GSYS3566G	40
GL3021LG	156	GL3560L	152	GL5027RG	159	GL5772R	155	GSYS3572	35
GL3021R	151	GL3560LG	157	GL5030L	154	GL5772RG	160	GSYS3572G	40
GL3021RG	156	GL3560R	152	GL5030LG	159	GL5778L	155	GSYS3578	35
GL3024L	151	GL3560RG	157	GL5030R	154	GL5778LG	160	GSYS3578G	40
GL3024LG	156	GL3566L	152	GL5030RG	159	GL5778R	155	GSYS3584	35
GL3024R	151	GL3566LG	157	GL5036L	154	GL5778RG	160	GSYS3584G	40
GL3024RG	156	GL3566R	152	GL5036LG	159	GMB1524	52, 176	GSYS4218	36
GL3027L	151	GL3566RG	157	GL5036R	154	GMB1530	52, 176	GSYS4218G	41
GL3027LG	156	GL3572L	152	GL5036RG	159	GMB1536	52, 176	GSYS4224	36
GL3027R	151	GL3572LG	157	GL5042L	154	GMB1542	52, 176	GSYS4224G	41
GL3027RG	156	GL3572R	152	GL5042LG	159	GMB1548	52, 176	GSYS4230	36
GL3030L	151	GL3572RG	157	GL5042R	154	GMB1554	52, 176	GSYS4230G	41
GL3030LG	156	GL3578L	152	GL5042RG	159	GMB1560	52, 176	GSYS4236	36
GL3030R	151	GL3578LG	157	GL5048L	154	GMB2224	52, 176	GSYS4236G	41
GL3030RG	156	GL3578R	152	GL5048LG	159	GMB2230	52, 176	GSYS4242	36
GL3036L	151	GL3578RG	157	GL5048R	154	GMB2236	52, 176	GSYS4242G	41
GL3036LG	156	GL4218L	153	GL5048RG	159	GMB2242	52, 176	GSYS4248	36
GL3036R	151	GL4218LG	158	GL5054L	154	GMB2248	52, 176	GSYS4248G	41
GL3036RG	156	GL4218R	153	GL5054LG	159	GMB2254	52, 176	GSYS4254	36
GL3042L	151	GL4218RG	158	GL5054R	154	GMB2260	52, 176	GSYS4254G	41
GL3042LG	156	GL4221L	153	GL5054RG	159	GPLTBK	47	GSYS4260	36
GL3042R	151	GL4221LG	158	GL5060L	154	GS870924	295	GSYS4260G	41
GL3042RG	156	GL4221R	153	GL5060LG	159	GS870930	295	GSYS4266	36
GL3048L	151	GL4221RG	158	GL5060R	154	GS870948	295	GSYS4266G	41
GL3048LG	156	GL4224L	153	GL5060RG	159	GS870960	295	GSYS4272	36
GL3048R	151	GL4224LG	158	GL5066L	154	GS870960	295	GSYS4272G	41
GL3048RG	156	GL4224R	153	GL5066LG	159	GS870960	295	GSYS4278	36
GL3054L	151	GL4224RG	158	GL5066R	154	GSTF12	53, 177	GSYS4278G	41
GL3054LG	156	GL4227L	153	GL5066RG	159	GSTF18	53, 177	GSYS4284	36
GL3054R	151	GL4227LG	158	GL5072L	154	GSTF24	53, 177	GSYS4284G	41
GL3054RG	156	GL4227R	153	GL5072LG	159	GSTF30	53, 177	GSYS5018	37
GL3060L	151	GL4227RG	158	GL5072R	154	GSTF36	53, 177	GSYS5018G	42
GL3060LG	156	GL4230L	153	GL5072RG	159	GSTF42	53, 177	GSYS5024	37
GL3060R	151	GL4230LG	158	GL5078L	154	GSTF48	53, 177	GSYS5024G	42
GL3060RG	156	GL4230R	153	GL5078LG	159	GSTF54	53, 177	GSYS5030	37
GL3066L	151	GL4230RG	158	GL5078R	154	GSTF60	53, 177	GSYS5030G	42
GL3066LG	156	GL4236L	153	GL5078RG	159	GSTF66	53, 177	GSYS5036	37
GL3066R	151	GL4236LG	158	GL5718L	155	GSTF72	53, 177	GSYS5036G	42
GL3066RG	156	GL4236R	153	GL5718LG	160	GSTF78	53, 177	GSYS5042	37
GL3072L	151	GL4236RG	158	GL5718R	155	GSTFN7578	47, 171	GSYS5042G	42
GL3072LG	156	GL4242L	153	GL5718RG	160	GSTFN8184	47, 171	GSYS5048	37
GL3072R	151	GL4242LG	158	GL5721L	155	GSYS3018	34	GSYS5048G	42
GL3072RG	156	GL4242R	153	GL5721LG	160	GSYS3018G	39	GSYS5054	37
GL3078L	151	GL4242RG	158	GL5721R	155	GSYS3024	34	GSYS5054G	42
GL3078LG	156	GL4248L	153	GL5721RG	160	GSYS3024G	39	GSYS5060	37
GL3078R	151	GL4248LG	158	GL5724L	155	GSYS3030	34	GSYS5060G	42
GL3078RG	156	GL4248R	153	GL5724LG	160	GSYS3030G	39	GSYS5066	37
GL3518L	152	GL4248RG	158	GL5724R	155	GSYS3036	34	GSYS5066G	42
GL3518LG	157	GL4254L	153	GL5724RG	160	GSYS3036G	39	GSYS5072	37
GL3518R	152	GL4254LG	158	GL5727L	155	GSYS3042	34	GSYS5072G	42
GL3518RG	157	GL4254R	153	GL5727LG	160	GSYS3042G	39	GSYS5078	37
GL3521L	152	GL4254RG	158	GL5727R	155	GSYS3048	34	GSYS5078G	42

INDEX

Cross Reference Index

by Model Number

Model	Page	Model	Page	Model	Page	Model	Page	Model	Page
GSYS5084	37	GT3521	152	GT5727G	160	GTB1548	52, 176	P3AOP-IV15	82
GSYS5084G	42	GT3521G	157	GT5730	155	GTB1554	52, 176	P3AOP-IV22	82
GSYS5718	38	GT3524	152	GT5730G	160	GTB1560	52, 176	P3AOP-IV30	82
GSYS5718G	43	GT3524G	157	GT5736	155	GTB2224	52, 176	P3AOP-VH07	82
GSYS5724	38	GT3527	152	GT5736G	160	GTB2230	52, 176	P3AOP-VH15	82
GSYS5724G	43	GT3527G	157	GT5742	155	GTB2236	52, 176	P3AOP-VH22	82
GSYS5730	38	GT3530	152	GT5742G	160	GTB2242	52, 176	P3AOP-VH30	82
GSYS5730G	43	GT3530G	157	GT5748	155	GTB2248	52, 176	P3AOP-WM35	82
GSYS5736	38	GT3536	152	GT5748G	160	GTB2254	52, 176	P3AOP-WM42	82
GSYS5736G	43	GT3536G	157	GT5754	155	GTB2260	52, 176	P3AOP-WM50	82
GSYS5742	38	GT3542	152	GT5754G	160	GTEMP	151, 152, 153, 154, 155, 156, 157, 158, 159, 160	P3AOP-WM57	82
GSYS5742G	43	GT3542G	157	GT5760	155	GWPSF	53, 177	P3AOP-WM65	82
GSYS5748	38	GT3548	152	GT5760G	160	GWS30	47, 175	P3AOP-WM72	82
GSYS5748G	43	GT3548G	157	GT5766	155	GWS35	47, 175	P3AOP-WM80	82
GSYS5754	38	GT3554	152	GT5766G	160	GWS42	47, 175	P3CONB35N	82
GSYS5754G	43	GT3554G	157	GT5772	155	GWS40	47, 175	P3CONB42N	82
GSYS5760	38	GT3560	152	GT5772G	160	GWS50	47, 175	P3CONB50N	82
GSYS5760G	43	GT3560G	157	GT5778	155	GWS57	47, 175	P3CONB57N	82
GSYS5766	38	GT3566	152	GT5778G	160	GWSBK	47, 175	P3CONB65N	82
GSYS5766G	43	GT3566G	157	GT301824	151	LKFE	304	P3CONB72N	82
GSYS5772	38	GT3572	152	GT301824G	156	OH1524FD	127, 228	P3CONB80N	82
GSYS5772G	43	GT3572G	157	GT301830	151	OH1524HD	127	P3CONC35N	82
GSYS5778	38	GT3578	152	GT301830G	156	OH1524SD	127	P3CONC42N	82
GSYS5778G	43	GT3578G	157	GT302418	151	OH1530FD	127, 228	P3CONC50N	82
GSYS5784	38	GT4218	153	GT302418G	156	OH1530HD	127	P3CONC57N	82
GSYS5784G	43	GT4218G	158	GT302430	151	OH1530RD	128, 228	P3CONC65N	82
GSYS5784G	43	GT4218G	158	GT302430G	156	OH1530SD	127	P3CONC72N	82
GSYS5784G	43	GT4218G	158	GT303018	151	OH1536FD	127, 228	P3CONC80N	82
GSYS5784G	43	GT4218G	158	GT303018G	156	OH1536HD	127	P3CONGE	171
GSYS5784G	43	GT4218G	158	GT303024	151	OH1536RD	128, 228	P3CONGEG	171
GSYS5784G	43	GT4218G	158	GT303024G	156	OH1536SD	127	P3CONGM35D	171
GSYS5784G	43	GT4218G	158	GT351824	152	OH1536FD	127, 228	P3CONGM35S	171
GSYS5784G	43	GT4218G	158	GT351824G	157	OH1542FD	127, 228	P3CONGM42D	171
GSYS5784G	43	GT4218G	158	GT351830	152	OH1542HD	127	P3CONGM42S	171
GSYS5784G	43	GT4218G	158	GT351830G	157	OH1542RD	128, 228	P3CONGM50D	171
GSYS5784G	43	GT4218G	158	GT352418	152	OH1542SD	127	P3CONGM50S	171
GSYS5784G	43	GT4218G	158	GT352418G	157	OH1548FD	127, 228	P3CONGM57D	171
GSYS5784G	43	GT4218G	158	GT352430	152	OH1548HD	127	P3CONGM57S	171
GSYS5784G	43	GT4218G	158	GT352430G	157	OH1548RD	128, 228	P3CONGM65D	171
GSYS5784G	43	GT4218G	158	GT353018	152	OH1548SD	127	P3CONGM65S	171
GSYS5784G	43	GT4218G	158	GT353018G	157	OH1560FD	127, 228	P3CONGM72D	171
GSYS5784G	43	GT4218G	158	GT353024	152	OH1560RD	128, 228	P3CONGM72S	171
GSYS5784G	43	GT4218G	158	GT353024G	157	OH1560SD	127	P3CONL35N	81
GSYS5784G	43	GT4218G	158	GT421824	153	OH1572FD	127	P3CONL42N	81
GSYS5784G	43	GT4218G	158	GT421824G	158	P1AOP-TC24	77	P3CONL50N	81
GSYS5784G	43	GT4218G	158	GT421830	153	P1AOP-TC30	77	P3CONL57N	81
GSYS5784G	43	GT4218G	158	GT421830G	158	P1AOP-TC36	77	P3CONL65N	81
GSYS5784G	43	GT4218G	158	GT422418	153	P1AOP-TC42	77	P3CONL72N	81
GSYS5784G	43	GT4218G	158	GT422418G	158	P1AOP-TC48	77	P3CONL80N	81
GSYS5784G	43	GT4218G	158	GT422430	153	P1AOP-TC60	77	P3CONS1	80
GSYS5784G	43	GT4218G	158	GT422430G	158	P1AOP-TC72	77	P3CONS35N	81
GSYS5784G	43	GT4218G	158	GT423018	153	P1DMK30	79	P3CONS42N	81
GSYS5784G	43	GT4218G	158	GT423018G	158	P1DMK36	79	P3CONS50N	81
GSYS5784G	43	GT4218G	158	GT423024	153	P1DMK42	79	P3CONS57N	81
GSYS5784G	43	GT4218G	158	GT423024G	158	P1DMK48	79	P3CONS65N	81
GSYS5784G	43	GT4218G	158	GT501824	154	P2AOP-0724FG	79	P3CONS72N	81
GSYS5784G	43	GT4218G	158	GT501824G	159	P2AOP-0730FG	79	P3CONS80N	81
GSYS5784G	43	GT4218G	158	GT501830	154	P2AOP-0736FG	79	P3CONSL	80
GSYS5784G	43	GT4218G	158	GT501830G	159	P2AOP-0742FG	79	P3CONSS	80
GSYS5784G	43	GT4218G	158	GT502418	154	P2AOP-0748FG	79	P3CONST	80
GSYS5784G	43	GT4218G	158	GT502418G	159	P2AOP-0754FG	79	P3CONSV	80
GSYS5784G	43	GT4218G	158	GT502430	154	P2AOP-0760FG	79	P3CONSX	80
GSYS5784G	43	GT4218G	158	GT502430G	159	P2AOP-0766FG	79	P3CONSY	80
GSYS5784G	43	GT4218G	158	GT503018	154	P2AOP-0772FG	79	P3CONT35N	81
GSYS5784G	43	GT4218G	158	GT503018G	159	P2AOP-1524FG	79	P3CONT42N	81
GSYS5784G	43	GT4218G	158	GT503024	154	P2AOP-1530FG	79	P3CONT50N	81
GSYS5784G	43	GT4218G	158	GT503024G	159	P2AOP-1536FG	79	P3CONT57N	81
GSYS5784G	43	GT4218G	158	GT571824	155	P2AOP-1542FG	79	P3CONT65N	81
GSYS5784G	43	GT4218G	158	GT571824G	160	P2AOP-1548FG	79	P3CONT72N	81
GSYS5784G	43	GT4218G	158	GT571830	155	P2AOP-1554FG	79	P3CONT80N	81
GSYS5784G	43	GT4218G	158	GT571830G	160	P2AOP-1560FG	79	P3CONTNT	80
GSYS5784G	43	GT4218G	158	GT572418	155	P2AOP-1566FG	79	P3CONX35N	81
GSYS5784G	43	GT4218G	158	GT572418G	160	P2AOP-1572FG	79	P3CONX42N	81
GSYS5784G	43	GT4218G	158	GT572430	155	P3AOP-ET35	82	P3CONX50N	81
GSYS5784G	43	GT4218G	158	GT572430G	160	P3AOP-ET42	82	P3CONX57N	81
GSYS5784G	43	GT4218G	158	GT573018	155	P3AOP-ET50	82	P3CONX65N	81
GSYS5784G	43	GT4218G	158	GT573018G	160	P3AOP-ET57	82	P3CONX72N	81
GSYS5784G	43	GT4218G	158	GT573024	155	P3AOP-ET65	82	P3CONX80N	81
GSYS5784G	43	GT4218G	158	GT573024G	160	P3AOP-ET72	82	P278PP	93
GSYS5784G	43	GT4218G	158	GTB1524	52, 176	P3AOP-ET80	82	P2156PP	93
GSYS5784G	43	GT4218G	158	GTB1530	52, 176	P3AOP-GV07	82	P13524TP	76
GSYS5784G	43	GT4218G	158	GTB1536	52, 176	P3AOP-GV15	82	P13530TP	76
GSYS5784G	43	GT4218G	158	GTB1542	52, 176	P3AOP-IV07	82	P13536TP	76

INDEX

Cross Reference Index

by Model Number

Model	Page	Model	Page	Model	Page	Model	Page
P13542TP	76	RFDRWHUBEND	279	T53060S	111, 210	UH6548FDN	129
P13548TP	76	RFDRWHUBENDT	279	T53066B	115, 214	UH6548FDS	129
P13560TP	76	RFDRWHUBL	279	T53066S	111, 210	UH6560FD	230
P13572TP	76	RFDRWHUBLIN	279	T53072B	115, 214	UH6560FDA	129
P14224TP	76	RFDRWHUBT	279	T53072PL	115, 214	UH6560FDN	129
P14230TP	76	RFDRWHUBX	279	T53072PR	115, 214	UH6560FDS	129
P14236TP	76	RFDRWLEG	278	T53072S	111, 210	UH6566FD	230
P14242TP	76	RFDRWSC48	281	T53078S	111, 210	UH6566FDA	129
P14248TP	76	RFDRWSC54	281	T53084S	111, 210	UH6566FDN	129
P14260TP	76	RFDRWSC60	281	T53090S	111, 210	UH6566FDS	129
P14272TP	76	RFDRWSC66	281	T53096S	111, 210	UH6572FD	230
P15024HP	78	RFDRWSC72	281	T53624SC	113, 212	UH6572FDA	129
P15024TP	76	RFDRWWM	280	T53660B	115, 214	UH6572FDN	129
P15030HP	78	T6BK	120	T53666B	115, 214	UH6572FDS	129
P15030TP	76	T6CB12L	120	T53672B	115, 214	UHTB36	129, 230
P15036HP	78	T6CB12R	120	T54224SC	113, 212	UHTB42	129, 230
P15036TP	76	T6CB18L	120	T54230SC	113, 212	UHTB48	129, 230
P15042HP	78	T6CB18R	120	T54662JL	115, 214	UHTB60	129, 230
P15042TP	76	T6CB24L	120	T54662JR	115, 214	UHTB66	129, 230
P15048HP	78	T6CB24R	120	T54663JL	115, 214	UHTB72	129, 230
P15048TP	76	T6SB	120	T54663JR	115, 214	UN2HPSQ	280
P15060HP	78	T7DV	127, 129, 229, 230	T54722JL	115, 214	UN2HPSQSK	280
P15060TP	76	T612FB	120, 219	T54722JR	115, 214	WANDFS	296
P15072HP	78	T624CB	120, 219	T54723JL	115, 214	WANDFSOC	296
P15072TP	76	T624FB	120	T54723JR	115, 214	WANDFSUSB	296
P16524HP	78	T630FB	120	T54824SC	113, 212	WKSWMC	271, 297.2
P16524TP	76	T5622EL	114, 213	T54830SC	113, 212	Z2UP24	127
P16530HP	78	T5622ER	114, 213	TAWG	94, 191	Z2UP30	127
P16530TP	76	T5623EL	114, 213	TK365YEB	121	Z2UP36	127
P16536HP	78	T5623ER	114, 213	TK365YM	121	Z2UP42	127
P16536TP	76	T5632EL	114, 213	TKCWD29L	121	Z2UP48	127
P16542HP	78	T5632ER	114, 213	TKCWD29R	121	Z2UP60	127
P16542TP	76	T5633EL	114, 213	TKDPA29L	121	Z4UP24	127
P16548HP	78	T5633ER	114, 213	TKDPA29R	121	Z4UP30	127
P16548TP	76	T5722EL	114, 213	TKEB29L	121	Z4UP36	127
P16560HP	78	T5722ER	114, 213	TKEB29R	121	Z4UP42	127
P16560TP	76	T5723EL	114, 213	TKEP1129PL	120, 121	Z4UP48	127
P16572HP	78	T5723ER	114, 213	TKEP1129PR	120, 121	Z4UP60	127
P16572TP	76	T5732EL	114, 213	TKEP2429PL	120, 121	Z5SC42	112, 211
P21524G	78	T5732ER	114, 213	TKEP2429PR	120, 121	Z5SC48	112, 211
P21524T	76	T5733EL	114, 213	TKEP3029PL	120, 121	Z5SC54	112, 211
P21530G	78	T5733ER	114, 213	TKEP3029PR	120, 121	Z5SC60	112, 211
P21530T	76	T5822EL	114, 213	TKMP60	122	Z5SC66	112, 211
P21536G	78	T5822ER	114, 213	TKMP66	122	Z5SC72	112, 211
P21536T	76	T5832EL	114, 213	TKMP72	122	Z5SC78	112, 211
P21542G	78	T5832ER	114, 213	TKPPBL	120	Z5SC84	112, 211
P21542T	76	T5922EL	114, 213	TKPPBR	120	Z15042SD	79
P21548G	78	T5922ER	114, 213	TKSB29	121	Z16542SD	79
P21548T	76	T5932EL	114, 213	TKSL2429P	120, 121	Z18042SD	79
P21560G	78	T5932ER	114, 213	TKSL3029P	120, 121	ZS24	127
P21560T	76	T52024S	111, 210	TNS2424SD	113	ZS30	127
P21572G	78	T52030S	111, 210	TT629SC	120	ZS36	127
P21572T	76	T52036S	111, 210	TT53660BT	112, 211	ZS42	127
P23024G	78	T52042S	111, 210	TT53666BT	112, 211	ZS48	127
P23030G	78	T52048S	111, 210	TT53672BT	112, 211	ZS60	127
P23036G	78	T52054S	111, 210	TWTH	127, 228	ZS72	127
P23042G	78	T52060S	111, 210	U7WDA	292		
P23048G	78	T52066S	111, 210	U8SBKCH	65		
P23060G	78	T52072S	111, 210	U9TF	283		
P48042DP	79	T52078S	111, 210	U9TM	283		
P51500	117	T52084S	111, 210	U9TP	283		
P51500-42	117	T52090S	111, 210	U9TS	283		
PMP41	122, 222	T52096S	111, 210	U9WTC	94, 191, 283		
PMP47	122, 222	T52424S	111, 210	U912WTR	283		
PMP53	122, 222	T52430S	111, 210	U918WTR	283		
POHRTA36S	128	T52436S	111, 210	U924WTR	283		
POHRTA48S	128	T52442S	111, 210	U930WTR	283		
POHRTA1536FD	128	T52448S	111, 210	U936WTR	283		
POHRTA1542FD	128	T52454S	111, 210	U942WTR	283		
POHRTA1548FD	128	T52460S	111, 210	U948WTR	283		
PREPCVTR	94	T52466S	111, 210	U954WTR	283		
PRFTSKCL	296	T52472S	111, 210	U960WTR	283		
PRFTSKFS	296	T52478S	111, 210	U966WTR	283		
PRFTSKTR	296	T52484S	111, 210	UH6536FD	230		
RFDRW48	278	T52490S	111, 210	UH6536FDA	129		
RFDRW54	278	T52496S	111, 210	UH6536FDN	129		
RFDRW60	278	T53024S	111, 210	UH6536FDS	129		
RFDRW66	278	T53030S	111, 210	UH6542FD	230		
RFDRW72	278	T53036S	111, 210	UH6542FDA	129		
RFDRWAB	278	T53042S	111, 210	UH6542FDN	129		
RFDRWCNPP	280	T53048S	111, 210	UH6542FDS	129		
RFDRWCNPPE	280	T53054S	111, 210	UH6548FD	230		
RFDRWCNPPM	280	T53060B	115, 214	UH6548FDA	129		

Notes



Allsteel®

Allsteel Inc.
Muscatine, Iowa 52761

allsteeloffice.com

Form #A8747.A7 (06/24)