

Seating, Social Collaborative & Tables

Price & Specification Guide 2024

Prices effective February 1, 2024

PDF updated May 9, 2024

All content marked in red signifies an update to the previous version of this price guide published on February 1, 2024.

Limited Lifetime Warranty

Our unwavering commitment to our customers compels us to care, and our dedication to quality is just one of the ways we show our customers how much they mean to us.

We recognize that keeping up with the pace of change requires having products that work as hard as the people who use them. That's why each of our products is rigorously tested and certified to meet the highest industry standards.

In the unlikely event that any Allsteel product or component covered by the Allsteel Warranty should fail under normal workplace use because of defective material or workmanship, Allsteel promises to fix it. Because taking care of *people* is how Allsteel takes care of business.

For information on Allsteel's warranty coverage, visit AllsteelOffice.com.

Government Support – GovernmentSupport@hniworkplacefurnishings.com
Product, Parts, Non-Warranty Parts Orders – ProductSupport@hniworkplacefurnishings.com
Quick Ship Orders – QuickShip@hniworkplacefurnishings.com
Order Status – OrderStatus@hniworkplacefurnishings.com
General Inquiries – GeneralSupport@hniworkplacefurnishings.com

- Software support packages furnished to the customer, either by Allsteel® or by another source, which support the sale of Allsteel products are superseded by printed price lists.
- Prices are subject to change without notice. All orders are subject to prices in effect at the time of order.
- Please refer to your Allsteel Dealer Sales and Discount Policies for order placement information, terms and conditions.
- Additional copies of this Specification and Price List are available upon request from Allsteel Literature at 1-866-255-7833.

- Ordering information appears at the bottom of each product page complete with examples on how to specify. Fabric and finish pages are referenced at the bottom of product pages.

This publication is available as an interactive or downloadable PDF at www.allsteeloffice.com.

Questions or Comments?

Please call us at: **888-ALLSTEEL**
888-255-7833

Limited Lifetime Warranty [Inside Front Cover](#)
Table of Contents [3-4](#)

INTRODUCTION/SPECIFICATION

New, Revised, and Discontinued Products [5](#)
COM Policy [6-8](#)
Everyday Advantage® [9](#)
Upholstery and Finishes [10-42](#)

SEATING

Seating Statement of Line [43-44](#)
Seating BIFMA Guidelines [45](#)
Definitions and Acronyms [46](#)
Acuity® [48-55](#)
Clarity® [56-59](#)
Evo™ [60-65](#)
Inspire® [67-85](#)
Lyric™ [86-101](#)
Mimeo™ [102-105](#)
Nimble® [106-107](#)
O6 [108-111](#)
Pli [112-115](#)
Quip™ [116-117](#)
Relate® [118-133](#)
Seek® [134-137](#)
Svelte [139-141](#)
Vicinity™ [142-145](#)
Upholstery Grades 9-22 Pricing [146-150](#)

SOCIAL COLLABORATIVE

Social Collaborative Statement of Line [151-154](#)
ASI Social Collab Matrix [156-163](#)

Seating Collections

Jetty:Mod [165-200](#)
Townhall [201-214](#)
Park [215-226](#)
Recharge [227-243](#)
Rise™ [244-258](#)
Retreat™ [260-267](#)
Parallel™ [268-276](#)
Two Thirds [278-289](#)
Vicinity Lounge [290-293](#)
ColHo [294-295](#)
Linger™ [296-299](#)
Reflect™ [300-303](#)
Clubhouse™ [304-317](#)
Upholstery Grades 9-22 Pricing [318-324](#)

Social Collaborative Accent Tables

Statement of Line [325](#)
Finishes [326](#)
Belong® [327-328](#)
Parallel [329](#)
Rise [330-331](#)
Two Thirds [332-335](#)
Park [336-338](#)

Social Collaborative Laptop Tables

Statement of Line [339](#)
Finishes [340](#)
Recharge [341](#)
Rise [342](#)

Social Collaborative Meeting Tables

Statement of Line [343](#)
Finishes [344](#)
Park [345-346](#)
Townhall [347-349](#)
Recharge [350](#)

Social Collaborative Conferencing

Statement of Line [351](#)
Finishes [352](#)
Park [353-354](#)

TABLES

Admix™

Overview [355](#)
Grain Direction and Alignment [356](#)
Paint, Finishes, Laminates, and Veneers [357-358](#)
Statement of Line [359-360](#)
Electrical Overview [361](#)
Wire Management [362-363](#)
Reconfigurable Telescoping Tables [364](#)
Reconfigurable Tables [365-366](#)
Fixed Tables [367](#)
Personal Tables [368-369](#)
Reconfigurable and Personal Table Bases [370](#)
Modesty Panels [371](#)
Meeting Tables [372-377](#)
Small Meeting Tables [378-380](#)
V Media Tables [381](#)
Full Rounds — Open Center [382](#)
Media Tables [383-384](#)
Media Walls [385-386](#)
Perch Tables [387-388](#)
Console Tables [389](#)
Project Carts [390](#)
Satellite Tables [391](#)
Accessories [392-395](#)

Seating, Collaborative, & Tables

Specification and Price List

Effective Date February 1, 2024

Altitude®

Tables Overview.....	397
Paint Finishes, Laminates, Eased Edge	398
Fabrics.....	399
Working with Height-Adjustable Tables	400-405.2
Screens and Power Module	406
Altitude - Metal Screens	407-408
Power Rail Specifications	409-415
Working with Electrical and Data	416-420
Working with Organization Rail & Accessories & Screens.....	421
Altitude Height-Adjustable Tops, Bases, & Accessories.....	422-427.3
Altitude – A6.....	422-423
Worksurfaces for Height-Adjustable Bases	424-426
Cable Management.....	427-427.3
Power Rail – Electrical Components.....	428-430
A8 Screen Kits.....	431
Metal Screens and Tackboard Accessories.....	432-433
Power Rails and Accessories	434-437
Worksurface Mounted Rail and Accessories	438

EXTENSIONS™

Introduction	440
Working with Ergonomic Accessories	441-442
Working with Organization Tools.....	443-448
Working with Illumination.....	449-452
Power/Data Modules and Wire Management	453-453.4

ACCESSORIES

Working with Pivot Monitor Arms	454-457
---------------------------------------	---------

AWARE®

Finishes	458
Aware Overview.....	459-462
Aware Electrical	463-464
Aware Tops and Bases.....	465-466
18"D Tops and Fixed or Nesting Legs	467-468
24"D Tops and Fixed or Nesting Legs	469-472
30"D Tops and Fixed or Nesting Legs	473-476
36"D Tops and Fixed or Nesting Legs	477-478
Trapezoid / Half-Round Tops and Legs.....	479-480
Polygon / Crescent / Connector Tops and Legs	481-482
Modesty Panels and Accessories.....	483-484
Electrical and Data.....	485-486
Buffet Credenza / Recycle Credenza.....	487-488
Mobile Marker and Tack Boards	489
Wall-Hung Marker Boards.....	490
Lectern	491
Aware Typical.....	492

HARVEST™

Paint Finishes, Laminates and Veneers	493
Working with Harvest Classic.....	494-496
Table Tops.....	497
End Table Bases.....	498
Electrical & Data	499
Working with Harvest Rustic.....	500
Rustic Powered	501
Rustic Non-Powered	502
Working with Harvest Metal	503
Metal Powered.....	504
Metal Non-Powered.....	505

STRUCTURE

Overview Table Tops.....	506
Grain Direction and Alignment.....	507
Paint Finishes and Laminates	508
Bases Overview	509
Working with Adaptive Tables	510
Electrical and Wire Management Overview	511
Structure Product	512-519
Structure Product Matrix	520-527
Round Tops.....	528
Square Tops.....	529
Soft Square Tops	530
Diamond Tops.....	531-532
Boat Tops	533
Racetrack Tops.....	534-536
Rectangle Tops	537-539
Media Tops	540-541
Panel Bases.....	542
Cube Bases	543
Cylinder Bases.....	544
X-Bases	545
Freestanding Media Base Kits	546
Round / Square Pedestal Bases	547-548
T-Leg / Post-Leg / Community Bases.....	549
Adjustable Tables / Adaptive Tables	550
Cable / Wire Management.....	551-551.1
Electrical	552-554

APPENDIX

Touch-Up Paint	555
Fabric Care and Sustainability Information	556-557
Cross Reference Index by Model Number	558-569

ITEMS ON GSA CONTRACT

Please note, in order to verify if an item is on GSA Contract or is “Open Market,” please use Compass quoting which is updated in real time with all GSA contract changes. If you need additional assistance, please contact your local sales representative.

NEW FINISHES

- Wilsonart Solid Surface
 - Designer White – SDW4
 - Frosty White – SFW3
 - Night Stars – SNS5
 - Masoned Concrete – SMC2
 - Monte Amiata – SMA1
- Studio Paints
 - Ochre – P093
 - Sienna – P092
 - Cove – P096
 - Harbor – P097
 - Sage – P095
 - Dune – P094
- Stratawood Beigewood Maple SE878
- Stratawood Field Elm Maple SE599
- Stratawood Belair Maple SE934
- Stratawood Florence Walnut ST579
- Natural Florence Walnut NT579
- Quarter Florence Walnut QT579
- Fawn Cypress RF108
- Belair LWBA
- Field Elm LWFE

NEW TEXTILES

- Livi with Supreen
- Oxford with Supreen
- Rush
- Balance
- Beaux
- Belmont
- Bradbury
- Caspian
- Centric
- Connect
- Constance with Supreen
- Curator
- Editor
- Essence
- Fedora
- Loop
- Lugano with Supreen
- Mira
- Moxie (new colors): Bermuda, Brigade, Butterscotch, Cozumel, Dover, Forsythia, Grenache, Midnight, Muslin, Pacifica, Phantom, Whirlwind
- Noble Seating
- Notion
- Saxony
- Shift
- Sonnet
- Sydney
- Tango
- Truss
- Vibe
- Zip

DE-EMPHASIZED PRODUCTS

- Nimble Plastic Shells and Cart — 6/30/2024
- Reflect Seating — 12/31/2024
- Electrical 4-Wire Ports — 6/30/24
- Aware Wire Troughs — AW4W48, AW4W72, AW4W84 — 6/30/2024

DE-EMPHASIZED FABRICS

- Optic — 6/30/2024
- Taylor — 6/30/2024
- Dotty — 12/31/2024
- Inertia — 12/31/2024
- Mica — 12/31/2024
- Hamilton — 12/31/2024

COM Program

Allsteel understands that customers may at times want to specify fabrics outside of Allsteel's standard fabric offering. Our COM program was designed to make specifying COMs on Allsteel products a simpler, friendlier, and hassle-free process. This process is simple and easy to use, and is described below under "Allsteel to Supply (ATS)." If a Dealer wishes to manage the COM process themselves, they can do so by following guidelines under "Dealer to Supply (DTS)". **ATS is the preferred method for all COM fabrics.** With ATS, Company will provide acknowledgment based upon planned date of receipt of COM fabric and manage the entire process. DTS is allowed if it is not a partnership fabric or if Company does not have access to the supplier. **DTS may cause order delays and is strongly discouraged.** Find out more about Allsteel's COM process by emailing our COM Department at allsteelcomteam@allsteeloffice.com.

Allsteel to Supply (ATS):

1. Select the fabric you wish to use and check the COM Search on our Website at: AllsteelOffice.com/Design Resources/Textiles & Finishes/COM Search or COM Search quick link. You will need to have the COM supplier's name, fabric pattern name, and color name to search for approved fabrics.
2. If your fabric is listed as an approved fabric, you may place your order directly with Allsteel Customer Support. Please use the fabric code (e.g., S216426XP) from the COM Test Request on your order in the place of the standard fabric code.

If your fabric is not listed as approved, you will need to select the "Request COM Test" link on the COM Search website. If your fabric is not listed as approved, and it is not a Partnership fabric you may request a "Dealer to Supply" code. Select the "Request COM Test" link on the COM Search website. Your name, company name and email will be prepopulated fields. The secondary email, project name, and bid/contract number are optional information. The supplier, pattern, and color will show a list by clicking in the box and entering the first letter of the name and these are free form text boxes. Once that information is entered click add. (Multiple series can be added to the same request if they are the same supplier, pattern, and color.) Then click submit.
3. An email will be sent to the to the requestor stating the COM Request was successfully submitted. Up to four emails could be received: Testing materials requested, in testing, and final approval/denial with price grade and fabric code. It's rare actual test yardage is required. Testing is mainly done by reviewing the attributes of the fabric. The testing process takes approximately 48 hours. Written COM price quotes hold pricing for 90 days after issue date.
4. Once the fabric has been approved by Allsteel, enter your order directly with Allsteel Customer Support. Allsteel will purchase all COM fabric directly from the COM suppliers and schedule for production.

In the event that the Dealer decides to cancel a COM fabric order, the Dealer is responsible for the cost of the fabric plus a handling charge that is equal to 10% of the fabric cost.

Dealer to Supply (DTS):

1. Select the fabric you wish to use and check the COM Search on our Website at: AllsteelOffice.com/Design Resources/Textiles & Finishes/COM Search or COM Search quick link. Or call Allsteel Customer Support to see if the fabric you have chosen has already been tested and approved on the product you are interested in.

You will need to have the COM supplier's name, fabric pattern name, and color name for this inquiry.

2. If your fabric is not listed as approved, and it is not a Partnership fabric you may request a "Dealer to Supply" code. Select the "Request COM Test" link on the COM Search website. Your name, company name and email will be prepopulated fields. The secondary email, project name, and bid/contract number are optional information. The supplier, pattern, and color will show a list by clicking in the box and entering the first letter of the name and these are free form text boxes. Once that information is entered click add. (Multiple series can be added to the same request if they are the same supplier, pattern, and color.) Then click submit.
3. An email will be sent to the to the requestor stating the COM Request was successfully submitted. Up to four emails could be received: Testing materials requested, in testing, and final approval/denial with price grade and fabric code. It's rare actual test yardage is required. Testing is mainly done by reviewing the attributes of the fabric. The testing process takes approximately 48 hours.
4. Make sure to use a "Dealer to Supply" COM code (e.g., S216426ZP) and place your order directly with Allsteel Customer Support.
5. All "Dealer to Supply" orders will be charged Grade 4 pricing for seating, Grade 4 for Social Collaborative, and Grade D pricing for panels. Dealers will pay for the COM fabric separately.
6. All "Dealer to Supply" fabric must be sent on a fabric roll. Estimate the yardage required by using the yardage requirements listed in the price list by model. For questions please contact Allsteel Customer Support.
7. Place your fabric order directly with the COM Supplier with instructions for the fabric to be sent on a fabric roll to:

HNI Textile Distribution Center

COM Production Yardage — PO Number
Docks 20-22
301 Mulberry Avenue
Muscatine, IA 52761

Special Paint & Stain Policy

Allsteel at its own discretion may modify its standard products with non-standard paint and stain colors to meet specific needs. Dealer is required to submit a special paint or stain request via the COM Search on [our Website](#). A sample of the non-standard paint or stain color desired will be required for matching. Pricing, lead time, and order information will be provided at the time of approval.

- For each new requested stain or paint, there will be a \$500 net fee to cover supplier costs to match the special item.
- For existing, previously-approved stains or paints, there is no \$500 matching fee, however, there is a sample chip fee of \$175 net for stains and \$100 net for paints.
- Samples, preferably at least 3" x 5" chips, of the exact color desired should be sent to the Allsteel Tailored Products Group. Paint matches require (3) sample chips and stain matches require (3) sample chips. Please mail these sample chips to the address below and reference the Special Item Request Number from Tailored Solutions.

Allsteel Inc.

Attn: COM Team
200 Oak St.
Muscatine, IA 52761

- Allsteel will color match the sample and send control samples to the address provided in the request. Dealer will review Allsteel's color match and approve by signing the back of the sample chip. Send the signed sample back to the Allsteel Tailored Products Group.
- Special paints will be assigned a paint price grade.
- Orders will not be accepted until Allsteel receives the Dealer's written approval on the color match.
- Extended lead times will apply on orders containing special paints or stains.
- Due to manufacturing techniques, materials, and quality issues, some exclusions will apply and some matches may be declined.

Important Notes

- Natural veneer is subject to nature's quality control. Differences in grain and color are naturally occurring variations and cannot be controlled by the manufacturer and cannot be considered as product defects. Natural veneer has the characteristics and beauty of a living organism; with its own variations of grain, growth, and color patterns. For these reasons, Natural veneer is preferred by many for its warmth and personal characteristics.
- Color changes will occur over time when wood is exposed to light. For this reason, when new product is ordered as an addition to existing product, there will be color variances between the old and new product. Please remember when specifying new product that although the species of veneer will be the same, additional product is being manufactured from a different tree. It may take several months for the new furniture to mature to the color level of existing product. Even with this maturation process the additional product will not be an exact match.

Special Laminate Policy

The Company at its own discretion may modify its standard products with non-standard laminates to meet specific needs. Contact the Allsteel Tailored Products Group for pre-approved Wilsonart, Formica, Nevamar and Pionite laminates and pricing for special laminates. When requesting a special laminate please supply manufacturer, along with name and pattern number of laminate.

- Extended lead times will apply on orders containing special laminates.
- Due to manufacturing techniques, materials, and quality issues, some product exclusions will apply and some requests may be declined.

GSA/FEDERAL CONTRACT INFORMATION:

Model numbers identified with the following verbiage "When purchased separately without a configurable TAA compliant end product, not on GSA contract" is to mean that these configurable parts or components:

- Have no functionality or capability without being integrated into an end product; and
- Are considered Open Market if purchased without a configurable TAA compliant end product.

Information that **MUST** be included in the packing slip attached to the DTS fabric:

1. Dealer's Purchase Order number to Allsteel
2. Allsteel's Tracking number for the COM fabric
3. Dealer Name
4. Yards of Fabric

If the fabric shipment does not match the correct fabric and yardage, Allsteel will notify the Dealer for resolution.

If Allsteel receives fabric with incorrect labeling or fabric yardage that cannot be linked to an Allsteel furniture order, Allsteel will hold the fabric for up to 4 weeks. After 4 weeks Allsteel will dispose of the fabric. There are no exceptions to this policy.

Specific to DTS orders - The customer should send only the amount needed for the order. Excess yardage, or yardage not attached to an order will be disposed of at Allsteel's discretion.

Any canceled orders are subject to cancellation charges up to the full value of the Allsteel product canceled. Allsteel will determine the actual cancellation charge at the time the cancellation is requested.

8. For additional details on "Dealer to Supply" fabric refer to your Allsteel terms and conditions.

Additional Policy Information:

The company assumes no responsibility for the overall appearance, flammability, normal durability, colorfastness, or any other quality standards. The company reserves the right to reject a COM if the quality of the COM is not satisfactory for the product. Should this occur, the customer will be notified with an explanation when the issue is found.

The company is not responsible for fabric that has become obsolete at the COM supplier, that is of poor quality, or that is delivered late to the manufacturer from the COM supplier.

All cancellations or changes to COM orders are subject to Company approval. Because of the nature of COM, special fabrics, finishes, and structural modifications, products ordered as specials and then canceled prior to shipment are subject to cancellation costs up to the full value of the product canceled. The company determines the actual cancellation charge at the time the cancellation is requested. Upon approval, a cancellation number is issued to the Customer.

Purchase orders will not be accepted or entered unless the testing process is complete with positive results.

If all testing has been previously completed, re-testing is only necessary if fabric is to be used on a different product, or pattern direction has changed from that previously approved.

Previous test results can be obtained by a customer on the COM Search on [our Website](#) or by calling Allsteel Customer Support.

All COM fabric will be applied to seating and panel systems Pattern Cut unless Railroad Cut is requested and approved on the COM Test Request. Any fabrics approved as a width pass, the dealer is responsible for clarifying Railroad Cut on orders containing items that are too large to support the Pattern Cut of a fabric application (any items larger than 48" high or wide).

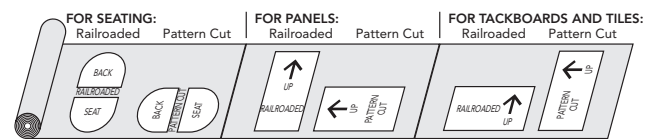

Fire Retardant

The Dealer is responsible for ensuring that the COM fabric is certified to meet all flame retardant requirements.

For more information, please contact Allsteel Customer Support.

YARDAGE REQUIREMENTS FOR FABRIC WITH REPEATS — FOR USE ON SOCIAL COLLABORATIVE PRODUCTS

Fabric Width	Plain Fabric	2"– 14" Repeat	15"– 19" Repeat	20"– 27" Repeat	28"– 36" Repeat
54"	0	+15%	+20%	+25%	+30%
53"	+6%	+19%	+24%	+28%	+36%
52"	+13%	+23%	+28%	+33%	+38%
51"	+19%	+26%	+31%	+36%	+41%
50"	+25%	+30%	+35%	+40%	+45%
49"	+30%	+35%	+40%	+45%	+50%
48"	+35%	+40%	+45%	+50%	+55%
47"	+45%	+50%	+55%	+58%	+65%

Depending upon the pattern repeat, it may be necessary to pattern cut the fabric. This will require 10% additional fabric.

To calculate multiple repeats (vertical and horizontal), add each repeat for total yardage required. For example for a fabric width of 54": 7" vertical requires 15%, 15" horizontal requires 20% total additional yardage required equals 35% (15% + 20%). Therefore, if your chair requires 2 yards of fabric, multiply 2 by 35%. Then 2.7 yards will be yardage required.

Everyday Advantage[®]

New terms and conditions for EDA:

1. Orders must clearly state “Everyday Advantage Order” and include the appropriate Everyday Advantage contract number:
 - Everyday Advantage Std-0125, Everyday Advantage Canada-0127
2. Everyday Advantage orders are not eligible for bid pricing.
3. Program discounting includes the complete Optimize, Further, and Terrace systems lines, private office solution, Approach and Involve storage. This program also includes Acuity, Evo, Inspire, Lyric, Mimeo, Nimble, Quip, Relate, Seek, and Svelte, seating. Altitude, Aware, and Structure tables are also available, along with Align pedestals, lockers and metal storage and Essentials pedestals, and Raddi storage lines. In addition, Extensions ergonomic accessories and lighting are part of the standard offering. All other product not called out is available for order on the contract but will receive standard discounting of 55%–65%.
4. All textiles and finishes except for veneer and some wood finishes are available, depending on quantity and selection, and may have extended lead times.
5. Everyday Advantage orders are not limited to a minimum or maximum.
6. All orders ship based on standard lead times. Large-quantity orders of like products may be subject to longer lead times.
7. Standard freight terms apply.
8. If driver assistance is needed, standard driver assist charges will be added at time of order entry.

Allsteel Inc. reserves the right to amend or terminate this program at anytime with 30 days written notice. Allsteel is not liable for service delays caused by force majeure (circumstances beyond Allsteel's control).

Refer to pages 13-16 for current upholstery availability by model/series.

GSA Reference Page

ALLSTEEL MATERIALS PARTNERSHIP PROGRAM — See program explanation at bottom of page.

UPHOLSTERY

GRADE 2	GRADE 4	GRADE 4 – continued	GRADE 4 – continued	GRADE 4 – continued
Maharam MELD (68% Recycled Polyester, 32% Polyester)	HBF Textiles BLINK	Maharam MANNER	Maharam MESSENGER — continued	Maharam METRIC — continued
Amethyst.....SMHMMLD18	Bright Blue 1048-59	Ablaze SMHMMAN13	BlanchSMHMGRM89	Downpour* SMHMMET33
Antler.....SMHMMLD13	Dark Violet 1048-77	Aquatic SMHMMAN22	Cactus*SMHMGRM45	Driftwood* SMHMMET06
Bare.....SMHMMLD26	Dove Grey..... 1048-83	Atmospheric* SMHMMAN36	Capri.....SMHMGRM61	Envy* SMHMMET21
Blonde.....SMHMMLD27	Lemon Yellow 1048-22	Baroness* SMHMMAN53	CassiaSMHMGRM66	Film.....SMHMMET31
Bride.....SMHMMLD10	Ocean Blue..... 1048-56	Basin SMHMMAN26	Catalyst*SMHMGRM98	Fleece* SMHMMET03
BuildSMHMMLD09	Peppery 1048-90	Butterscotch* SMHMMAN16	Cherry.....SMHMGRM69	Fog* SMHMMET02
Clementine.....SMHMMLD23	Red Orange..... 1048-44	Caper* SMHMMAN19	Chestnut*SMHMGRM52	Fruit* SMHMMET42
CometSMHMMLD29	Sea Green 1048-67	Carob* SMHMMAN02	Chili*SMHMGRM83	GalahSMHMMET43
Crater.....SMHMMLD14	Silvery 1048-80	Charisma* SMHMMAN49	CloudSMHMGRM31	Hedgerow* SMHMMET36
CreekSMHMMLD40	Maharam CAPER	Citronella* SMHMMAN45	DepthSMHMGRM38	Highway* SMHMMET38
Fox.....SMHMMLD24	Bliss.....SMHMCAP09	Cloudburst* SMHMMAN37	Dipper.....SMHMGRM92	Hopscotch.....SMHMMET30
Fuchsia.....SMHMMLD17	Cactus*SMHMCAP08	Cocoa* SMHMMAN08	Electric*SMHMGRM88	Kiln* SMHMMET44
GlobeSMHMMLD42	Cameo*SMHMCAP10	Cola* SMHMMAN10	EvergladeSMHMGRM87	Lava SMHMMET13
GlossSMHMMLD08	Cinnamon*SMHMCAP04	Comfort* SMHMMAN42	Fennel*SMHMGRM59	Midday SMHMMET34
Grate.....SMHMMLD07	Cougar*SMHMCAP03	Cottage SMHMMAN23	Fireside*SMHMGRM82	Mineral* SMHMMET07
Heat.....SMHMMLD22	Note.....SMHMCAP06	Cruise SMHMMAN35	Fossil*SMHMGRM76	Moth* SMHMMET45
Honeydew.....SMHMMLD30	Paprika.....SMHMCAP05	Dahlia* SMHMMAN24	Gale*SMHMGRM93	Oriole* SMHMMET14
IsleSMHMMLD39	Ribbon*SMHMCAP11	Dill SMHMMAN43	HunterSMHMGRM94	Phantom* SMHMMET01
Kale.....SMHMMLD34	Sidekick.....SMHMCAP12	Ember* SMHMMAN11	Husk*SMHMGRM81	Pollen* SMHMMET18
KissSMHMMLD25	Silverback.....SMHMCAP07	Firth* SMHMMAN39	Hydrangea*SMHMGRM50	Scuba* SMHMMET28
Knight.....SMHMMLD04	Smolder*SMHMCAP13	Flint SMHMMAN04	IceSMHMGRM46	Seaport.....SMHMMET27
Magma.....SMHMMLD20	Whim*SMHMCAP01	Grandeur* SMHMMAN41	Kill*SMHMGRM57	Skate SMHMMET29
Mariner.....SMHMMLD41	Wise*SMHMCAP02	Greenway* SMHMMAN21	Lilac*SMHMGRM51	Snorkel* SMHMMET37
Merlot.....SMHMMLD19	Stinson HIVE	Harvest* SMHMMAN17	Lim.....SMHMGRM95	Sourdough* SMHMMET04
Mimosa.....SMHMMLD28	AegeanSCFSHVE77	Hush SMHMMAN05	LongspurSMHMGRM90	Sunny SMHMMET40
Mulberry.....SMHMMLD16	BrickSCFSHVE81	Kimono SMHMMAN51	LumaineSMHMGRM54	Talisman SMHMMET35
Nordic.....SMHMMLD36	Bumble.....SCFSHVE73	Lattice* SMHMMAN30	Maize*SMHMGRM72	Tar* SMHMMET23
PandaSMHMMLD02	Chili*SCFSHVE75	Lioness* SMHMMAN18	MaoSMHMGRM25	Toffee* SMHMMET05
PerennialSMHMMLD15	Honeycomb*SCFSHVE80	Magic* SMHMMAN01	Neon*SMHMGRM48	Tupelo* SMHMMET19
PipeSMHMMLD06	Hornet*SCFSHVE72	Magnetic SMHMMAN32	NileSMHMGRM40	Twilight* SMHMMET25
Quill.....SMHMMLD05	SlateSCFSHVE71	Nuance SMHMMAN06	Onyx.....SMHMGRM29	Whale* SMHMMET32
Reef.....SMHMMLD37	VioletSCFSHVE79	OceansideSMHMMAN40	Oyster*SMHMGRM79	Maharam MODE
RoosterSMHMMLD21	WaterSCFSHVE74	Parakeet SMHMMAN20	Pensive*SMHMGRM80	Alder* SMHMMOD23
SeashellSMHMMLD12	Stinson LATERAL (100% Recycled Polyester)	Passerine SMHMMAN46	Peridot*SMHMGRM60	Angelfish* SMHMMOD32
SeedSMHMMLD33	Calypso.....SCFSLAT43	Peel SMHMMAN14	Poppy*SMHMGRM24	Ballpoint* SMHMMOD29
SkylineSMHMMLD03	Citrine.....SCFSLAT41	Penny* SMHMMAN15	Robust*SMHMGRM84	Barberry* SMHMMOD25
SpaSMHMMLD43	Horizon.....SCFSLAT42	Poplar* SMHMMAN44	Satsuma.....SMHMGRM71	Billygoat.....SMHMMOD10
StarkSMHMMLD11	MistSCFSLAT40	Porpoise SMHMMAN03	Shadow*SMHMGRM07	BlushSMHMMOD21
VastSMHMMLD01	PapayaSCFSLAT45	Resolute* SMHMMAN34	SnowSMHMGRM58	Bonsai* SMHMMOD40
VineSMHMMLD32	Peppercorn*SCFSLAT46	Roseate SMHMMAN48	Spice*SMHMGRM68	Carotene* SMHMMOD20
Waterfall.....SMHMMLD35	PangriaSCFSLAT47	Schooner SMHMMAN27	Squall*SMHMGRM63	Celtic* SMHMMOD38
Wave.....SMHMMLD38	SangriaSCFSLAT47	Siltstone SMHMMAN50	TangeloSMHMGRM53	Clavicle SMHMMOD09
WildSMHMMLD31	Skyline*SCFSLAT48	Silverpoint.....SMHMMAN29	Tobacco*SMHMGRM06	Cottontail* SMHMMOD16
	Sterling.....SCFSLAT44	Slope* SMHMMAN28	Tusk*SMHMGRM78	Crush SMHMMOD34
	HBF Textiles LOOK-SEE	Smoky* SMHMMAN31	Ultramarine*SMHMGRM62	Denim SMHMMOD33
	Electric 1044-77	Southwest* SMHMMAN47	Vibrant*SMHMGRM70	Eucalyptus* SMHMMOD39
	Foggy 1044-85	Thicket* SMHMMAN07	VoyageSMHMGRM86	Goldenrod.....SMHMMOD15
	Foliage 1044-67	Tidewater SMHMMAN38	Zinc*SMHMGRM10	Henge* SMHMMOD17
	Lava 1044-44	Valiant SMHMMAN52	Maharam METRIC	Hollow SMHMMOD04
	Midnight..... 1044-59	Vivid* SMHMMAN25	Admiral.....SMHMMET26	Intaglio SMHMMOD05
	Plum..... 1044-75	Wagon* SMHMMAN12	Alligator.....SMHMMET20	Jetty SMHMMOD32
	Shady 1044-80	Woad SMHMMAN33	AnchorSMHMMET24	Kermes* SMHMMOD24
	Snowy 1044-11	Maharam MESSENGER	Arabic* SMHMMET09	Lemon* SMHMMOD12
	Stone..... 1044-89	B, C, F, O, T (78% Recycled)	Aztec* SMHMMET41	Lichen* SMHMMOD43
	Terra Cotta 1044-46	AppleSMHMGRM96	Bittersweet* SMHMMET08	Lioness* SMHMMOD17
	Ultramarine..... 1044-57	AshSMHMGRM77	Bonsai* SMHMMET22	Machine SMHMMOD04
	Wavelet 1044-56	Aster*SMHMGRM67	Brick* SMHMMET11	Mallard* SMHMMOD37
	Wine 1044-74	AzureSMHMGRM41	Canary* SMHMMET39	Marsh* SMHMMOD26
		Balsa*SMHMGRM01	Caramel* SMHMMET17	Odyssey.....SMHMMOD08
		Bayou.....SMHMGRM08	Cardinal SMHMMET12	Ominous SMHMMOD03
		Beyond*SMHMGRM85	Cedar* SMHMMET15	Oriole.....SMHMMOD18
			Cerise* SMHMMET10	Oxeye.....SMHMMOD13
				Paradise* SMHMMOD31
				Petal* SMHMMOD26

Multi-use fabrics are noted with the following designators: **B** – Tackboards, **C** – Concensys®, **O** – Optimize™, **T** – Terrace®, **F** – Further™.

* Colorway not shown on Textiles card; all Partnership Program memo samples are available from supplier. See contact information below.

ALLSTEEL PARTNERSHIP PROGRAM

Allsteel understands that customers may want to specify panel and seating textiles outside of Allsteel's standard offering. Allsteel's Partnership Program consists of on-trend and design-forward patterns that have been tested and approved by Allsteel for use on Allsteel products. A subset of these approved patterns is available on cards in the textile binder, while numerous others are available on our website, allsteeloffice.com.

For memo samples, please contact our partners:

- Camira, memos@camirafabrics.com 1.616.288.0655
- CF Stinson, cfstinson.com 1.800.841.6279
- HBF Textiles, hbftextiles.com 1.877.494.5727
- Maharam, maharam.com 1.800.645.3943
- Ultrafabrics, ultrafabricsinc.com, 1.877.309.6648

The intent of the Partnership Program is to offer a wide variety of on-trend textiles to meet your varied needs, but since these textiles are not part of our standard offering they may be subject to extended lead times. Because new materials will be introduced regularly, Allsteel reserves the right to change the offering at any time.

Refer to pages 13-16 for current upholstery availability by model/series.

GSA Reference Page

ALLSTEEL MATERIALS PARTNERSHIP PROGRAM — SEE PROGRAM EXPLANATION AT BOTTOM OF PAGE 10.

GRADE 4 — continued

Maharam MODE — continued	
Rust*	SMHMMOD19
Saltwater	SMHMMOD36
Sassafras	SMHMMOD41
Spindle	SMHMMOD11
Stroll	SMHMMOD01
Sycamore	SMHMMOD08
Talus	SMHMMOD05
Toile*	SMHMMOD30
Valley*	SMHMMOD27
Vermilion	SMHMMOD22
Yucca*	SMHMMOD42

Maharam MULTIPLY

Contrast*	SMHMMLT04
Craft*	SMHMMLT11
Daze	SMHMMLT06
Deep	SMHMMLT10
Encore	SMHMMLT02
Limit*	SMHMMLT13
Mystique*	SMHMMLT09
Sailor	SMHMMLT08
Sterling	SMHMMLT05
Sway*	SMHMMLT07
Swing*	SMHMMLT03
Tamale*	SMHMMLT14
Town*	SMHMMLT12
Winter*	SMHMMLT01

Maharam MURMUR

Argan*	SMHMMUR17
Baby	SMHMMUR10
Bio	SMHMMUR15
Canopy*	SMHMMUR03
Case	SMHMMUR16
Cauldron	SMHMMUR06
Conquer*	SMHMMUR07
Dim	SMHMMUR04
Elderberry	SMHMMUR11
Gust	SMHMMUR01
Harmonica	SMHMMUR02
Iceberg	SMHMMUR12
Ignite	SMHMMUR19
Peppercorn	SMHMMUR05
Rapids	SMHMMUR08
Sangria*	SMHMMUR21
Seawater	SMHMMUR09
Sultry*	SMHMMUR20
Sundown*	SMHMMUR18
Tallgrass*	SMHMMUR13
Underground*	SMHMMUR14

Maharam MUSE

Ascend	SMHMMUS04
Bergamot*	SMHMMUS11
Celebrate	SMHMMUS30
Clear	SMHMMUS07
Compass	SMHMMUS10
Crescendo	SMHMMUS01
Fantasy*	SMHMMUS08
Frigid	SMHMMUS16
Goal	SMHMMUS13
Grasshopper	SMHMMUS12
Haven*	SMHMMUS24
Jovial	SMHMMUS27
Mead*	SMHMMUS25
Miso*	SMHMMUS09
Mistletoe	SMHMMUS14
Neat	SMHMMUS26
Noble	SMHMMUS18
Poinsettia	SMHMMUS29
Pulsar	SMHMMUS19
Refresh	SMHMMUS06
Resonator	SMHMMUS02
Riverbend	SMHMMUS17
Runway	SMHMMUS03
Sailboat*	SMHMMUS21
Seaglass*	SMHMMUS15
Sparse*	SMHMMUS22
Spectacle	SMHMMUS31
Theater	SMHMMUS28
Vase	SMHMMUS23
Veil*	SMHMMUS05
Velella*	SMHMMUS20

▲ Acuity Jacket Upholstery.

GRADE 4 — continued

Mayer Fabrics TANGO	
Camel	460-007
Coral	460-011
Flint	460-006
Harbor	460-014
Limeade	460-013
Raspberry	460-008
Sangria	460-001
Skyline	460-004
Sunrise	460-002
Surfside	460-024

Maharam TRUNDLE

Aloe	SMHMTRN05
Cabana*	SMHMTRN06
Confetti*	SMHMTRN09
Crabapple*	SMHMTRN10
Element	SMHMTRN02
Hibernite*	SMHMTRN04
Magnet	SMHMTRN11
Rainstorm*	SMHMTRN07
Ray	SMHMTRN03
Ski*	SMHMTRN01
Wake	SMHMTRN08

HBF Textiles WALKABOUT

Alluring Aqua	1046-56
Bewitched Blue	1046-59
Bold Burgundy	1046-74
Classic Cobalt	1046-55
Cool Carbon	1046-87
Gallant Green	1046-67
Gutsy Grey	1046-85
Jungly Jade	1046-64
Noble Navy	1046-58
Peaceful Pewter	1046-89
Reliable Red	1046-44
Swanky Silver	1046-80
Wistful White	1046-11

GRADE 5

HBF Textiles CHECKMATE

Aqua Sky	1043-56
Blue Green	1043-63
Charcoal Black	1043-89
Forest Mint	1043-66
Golden Grey	1043-22
Purple Indigo	1043-77
Red Brick	1043-44
Royal Navy	1043-58
Rust	1043-43
Smoke Slate	1043-80
Tanned Umber	1043-25

Mayer Fabrics FEDORA

Aegean	621-053
Aquamarine	621-043
Bitumen	621-006
Cactus	621-003
Charcoal	621-016
Citron	621-013
Dapper	621-036
Dew	621-056
Espresso	621-010
Eucalyptus	621-023
Fawn	621-017
Indigo	621-014
Light Grey	621-046
Midnight	621-004
Mink	621-000
Opal	621-033
Persimmon	621-009
Pewter	621-026
Plum	621-008
Purple	621-005
Ruby	621-001
Tangelo	621-019
Tomato	621-011
Topaz	621-002
Winter	621-007

GRADE 5 — continued

Camira MAIN LINE FLAX (Wool yarns blended with plant-based flax fibers)	
Aldgate	SCAMMLF01
Archway*	SCAMMLF02
Bank*	SCAMMLF23
Barbican	SCAMMLF03
Bayswater	SCAMMLF24
Bethnal	SCAMMLF25
Brompton*	SCAMMLF35
Camden*	SCAMMLF26
Charing	SCAMMLF27
Edgware*	SCAMMLF28
Euston	SCAMMLF04
Farringdon	SCAMMLF29
Finsbury	SCAMMLF30
Goldhawk*	SCAMMLF31
Greenford	SCAMMLF32
Highgate*	SCAMMLF33
Hillingdon*	SCAMMLF41
Holborn*	SCAMMLF05
Kensington	SCAMMLF07
Kilburn*	SCAMMLF06
Lambeth	SCAMMLF08
Leyton*	SCAMMLF13
Monument	SCAMMLF09
Mordon*	SCAMMLF12
Newbury	SCAMMLF10
Northfields*	SCAMMLF40
Paddington*	SCAMMLF39
Parsons*	SCAMMLF14
Pimlico*	SCAMMLF34
Russell*	SCAMMLF38
Stammore	SCAMMLF37
Stockwell*	SCAMMLF15
Temple*	SCAMMLF16
Tooting	SCAMMLF17
Tower*	SCAMMLF36
Tufnell	SCAMMLF18
Upminster*	SCAMMLF20
Victoria*	SCAMMLF19
Waterloo*	SCAMMLF21
Wembley	SCAMMLF11
Westminster	SCAMMLF22

Mayer Fabrics MIRA

Almond	330-007
Charcoal	330-016
Denim	330-024
Dijon	330-002
Fire	330-009
Grape	330-005
Grotto	330-013
Sangria	330-011
Sky	330-004
Slate	330-006
Spring	330-003
Straw	330-017
Water	330-014
Watermelon	330-001

CF Stinson RIDDLE

Black Coffee*	SCFSRID26
Chalkboard	SCFSRID25
Citron	SCFSRID22
Frost	SCFSRID21
Iris	SCFSRID20
Malt	SCFSRID19
Peppercorn*	SCFSRID23
Siren	SCFSRID18
Surf	SCFSRID24

CF Stinson SEQUENCE

Abyss	SCFSSEQ84
Alabaster	SCFSSEQ72
Burgundy	SCFSSEQ82
Cadet	SCFSSEQ81
Carbon	SCFSSEQ73
Crimson	SCFSSEQ78
Crisp	SCFSSEQ76
Navy	SCFSSEQ80
Orange	SCFSSEQ79
Peat	SCFSSEQ83
Putty	SCFSSEQ74
Silver Lining	SCFSSEQ75
Sky	SCFSSEQ77

GRADE 5 — continued

Mayer Fabrics ZIP	
Aubergine	ZIP-015
Chamois	ZIP-017
Coal	ZIP-036
Cobalt	ZIP-034
Denim	ZIP-024
Fog	ZIP-006
Haze	ZIP-016
Lavender	ZIP-005
Mocha	ZIP-000
Peacock	ZIP-013
Pine	ZIP-023
Punch	ZIP-001
Sea	ZIP-004
Sky	ZIP-014
Spring	ZIP-003
Storm	ZIP-026
Straw	ZIP-007

HBF Textiles ZIPPY

Dark Grey	1045-89
Deep Red	1045-44
Denim Blue	1045-58
Grey	1045-80
Navy	1045-59
Pine	1045-67
School Blue	1045-55
Winter White	1045-10

GRADE 6

Mayer Fabrics BALANCE

Caramel	BA-002
Celadon	BA-003
Copper	BA-009
Cream	BA-007
Denim	BA-004
Grey Mist	BA-026
Jade	BA-013
Metal	BA-006
Pinot	BA-008
Rose	BA-001
Sea	BA-014
Stone	BA-017
Thisle	BA-016

Mayer Fabrics BEAUX

Ablaze	366-019
Haze	366-004
Lantern	366-009
Majestic	366-005
Masonry	366-016
Navy	366-024
Palm	366-003
Peppercorn	366-026
Quarry	366-006
Raintree	366-013
Rogue	366-001
Sandstone	366-007
Taupe	366-000
Tidal	366-014

Camira BLAZER

(100% Pure New Wool)

Aberlour*	SCAMBLZ15
Aberthay	SCAMBLZ36
Aston	SCAMBLZ02
Barlborough*	SCAMBLZ40
Barnard	SCAMBLZ27
Bromsgrove*	SCAMBLZ35
Bryanston	SCAMBLZ53
Camphill	SCAMBLZ16
Cardiff*	SCAMBLZ04
Dartmouth	SCAMBLZ24
Dunhurst*	SCAMBLZ58
Edge Hill*	SCAMBLZ90
Edinburgh*	SCAMBLZ23
Eynesbury*	SCAMBLZ44
Fairfield	SCAMBLZ47
Glasgow*	SCAMBLZ01
Glenalmond	SCAMBLZ62
Goldsmith	SCAMBLZ39
Handcross*	SCAMBLZ63

GRADE 6 — continued

Camira BLAZER — continued	
Holyoke*	SCAMBLZ43
Hull*	SCAMBLZ19
Kingsmead*	SCAMBLZ67
Knightsbridge*	SCAMBLZ26
Latymer*	SCAMBLZ33
Magdalene*	SCAMBLZ42
Manchester	SCAMBLZ21
Marymount*	SCAMBLZ38
Montcrest*	SCAMBLZ37
Napier	SCAMBLZ08
Newcastle	SCAMBLZ22
Newport*	SCAMBLZ17
Oriel*	SCAMBLZ18
Oxford*	SCAMBLZ09
Penola*	SCAMBLZ45
Plymouth	SCAMBLZ20
Scottdale*	SCAMBLZ41
Sheffield*	SCAMBLZ03
Silcoates	SCAMBLZ30
Silverdale	SCAMBLZ28
St. Andrews	SCAMBLZ86
Stanford	SCAMBLZ25
Surrey	SCAMBLZ10
Trevelyan	SCAMBLZ31
Tyndale*	SCAMBLZ46
Ulster*	SCAMBLZ11
Vassar	SCAMBLZ34
Wellington	SCAMBLZ13
Wesley*	SCAMBLZ82
Winchester*	SCAMBLZ12
Woodcroft*	SCAMBLZ48

Mayer Fabrics ESSENCE

Bone	ES-007
Charcoal	ES-006
Citron	ES-013
Cocoa	ES-000
Hedge	ES-003
Indigo	ES-014
Ink	ES-004
Metal	ES-016
Peacock	ES-033
Pearl	ES-026
Persimmon	ES-009
Plum	ES-005
Port	ES-001
Sea	ES-023
Stone	ES-017
Sunray	ES-002
Tomato	ES-011
Truffle	ES-010

Camira HEMP

Acre	SCAMHMP19
Alec	SCAMHMP12
Arable	SCAMHMP04
Ashworth	SCAMHMP26
Bale	SCAMHMP02
Barn	SCAMHMP23
Dale	SCAMHMP18
Dew	SCAMHMP16
Fallow	SCAMHMP28
Gorse	SCAMHMP03
Grain	SCAMHMP27
Heath	SCAMHMP07
Hectare	SCAMHMP21
Hedgerow	SCAMHMP09
Oat	SCAMHMP05
Plough	SCAMHMP01
Pollen	SCAMHMP08
Root	SCAMHMP06
Seed	SCAMHMP13
Sickle	SCAMHMP30
Trough	SCAMHMP20

UPHOLSTERY

* Colorway not shown on Textiles card; all Partnership Program memo samples are available from supplier. See contact information on page 10.

Refer to pages 13-16 for current upholstery availability by model/series.

GSA Reference Page

ALLSTEEL MATERIALS PARTNERSHIP PROGRAM — SEE PROGRAM EXPLANATION AT BOTTOM OF PAGE 10.

UPHOLSTERY

GRADE 6 – continued

Mayer Fabrics LOOP	
Admiral.....	637-004
Citron.....	637-003
Cobalt.....	637-034
Driftwood.....	637-000
Earth.....	637-010
Grass.....	637-013
Indigo.....	637-044
Marine.....	637-024
Mineral.....	637-007
Ocean.....	637-014
Plum.....	637-005
Shadow.....	637-016
Smoke.....	637-006
Tangelo.....	637-009
Tomato.....	637-001
HBF Textiles POPPY	
Flame.....	1047-44
Graphite.....	1047-85
Ink.....	1047-89
Khaki.....	1047-35
Limelight.....	1047-63
Natural.....	1047-16
Neutral.....	1047-83
Night.....	1047-59
Pool.....	1047-56
Punch.....	1047-45

GRADE 7

Mayer Fabrics CASPIAN	
Almond.....	329-007
Cinder.....	329-016
Earth.....	329-010
Grotto.....	329-014
Ink.....	329-004
Jungle.....	329-013
Marine.....	329-024
Mineral.....	329-006
Mushroom.....	329-000
Sangria.....	329-021
Spring.....	329-003
Sunset.....	329-011
Tangelo.....	329-009
Watermelon.....	329-001
Mayer Fabrics CURATOR	
Cloud.....	WC921-006
Ink.....	WC921-004
Juniper.....	WC921-013
Metal.....	WC921-016
Mulberry.....	WC921-005
Onyx.....	WC921-026
Rhubarb.....	WC921-008
Ruby.....	WC921-001
Spearmint.....	WC921-003
Umber.....	WC921-002
Camira SILK	
Arabia.....	SCAMSLK02
Assam.....	SCAMSLK11
Brunei.....	SCAMSLK08
Byzantine.....	SCAMSLK03
Chancellor.....	SCAMSLK19
Divine.....	SCAMSLK13
Dynasty.....	SCAMSLK17
Emperor.....	SCAMSLK16
Empress.....	SCAMSLK05
Forbidden.....	SCAMSLK07
Imeon.....	SCAMSLK20
Incense.....	SCAMSLK06
Kingdom.....	SCAMSLK10
Monarch.....	SCAMSLK15
Oriental.....	SCAMSLK12
Pamir.....	SCAMSLK14
Parthian.....	SCAMSLK09
Persia.....	SCAMSLK04
Sahara.....	SCAMSLK01
Sovereign.....	SCAMSLK18
Tussah.....	SCAMSLK21

GRADE 7 – continued

Mayer Fabrics SONNET	
Amber.....	ST-002
Beach.....	ST-027
Chambray.....	ST-024
Cherry.....	ST-001
Cocoa.....	ST-010
Driftwood.....	ST-017
Ink.....	ST-044
Latte.....	ST-007
Laurel.....	ST-043
Mango.....	ST-009
Moss.....	ST-023
Ocean.....	ST-014
Pear.....	ST-013
Powder.....	ST-004
Rain.....	ST-034
Sage.....	ST-003
Silver.....	ST-016
Slate.....	ST-046
Smoke.....	ST-006
Taupe.....	ST-000
Terra.....	ST-019
Titanium.....	ST-036
Willow.....	ST-033
Zinc.....	ST-026

GRADE 8

Maharam APT (100% Silicone Face)	
Bengal.....	SMHMAPT25
Bloom.....	SMHMAPT29
Botanic.....	SMHMAPT20
Castle.....	SMHMAPT33
Charm.....	SMHMAPT36
Chartreuse.....	SMHMAPT21
Cobblestone.....	SMHMAPT11
Coconut.....	SMHMAPT01
Constellation.....	SMHMAPT07
Core.....	SMHMAPT26
Crepe.....	SMHMAPT22
Descend.....	SMHMAPT37
Eden.....	SMHMAPT15
Elixir.....	SMHMAPT35
Fluid.....	SMHMAPT14
Follow.....	SMHMAPT34
Fortress.....	SMHMAPT31
Galactic.....	SMHMAPT16
Garden.....	SMHMAPT19
Gingerbread.....	SMHMAPT05
Glacier.....	SMHMAPT10
Hickory.....	SMHMAPT06
Iris.....	SMHMAPT12
Jade.....	SMHMAPT18
Labyrinth.....	SMHMAPT08
Lotus.....	SMHMAPT30
Lumber.....	SMHMAPT04
Lyric.....	SMHMAPT23
Mantle.....	SMHMAPT17
Nocturnal.....	SMHMAPT27
Oak.....	SMHMAPT32
Shoreline.....	SMHMAPT17
Sketch.....	SMHMAPT09
Sorbet.....	SMHMAPT28
Stamper.....	SMHMAPT03
Turmeric.....	SMHMAPT24
Vibe.....	SMHMAPT02
Ultrafabrics BRISA® ▲	
Abyss*.....	RS78
Apple Green.....	RS25
Ash.....	RS05
Aztec*.....	RS16
Bark*.....	RS18
Beet Root*.....	RS361
Birch.....	RS64
Black Onyx.....	RS01
Blossom*.....	RS74
Blue Sea.....	RS621
Bone.....	RS31

GRADE 8 – continued

Ultrafabrics BRISA® — continued	
Cabernet.....	RS99
Cambridge Blue.....	RS17
Canyon*.....	RS07
Caramel.....	RS91
Celery.....	RS87
Cinnabar*.....	RS36
Coffee Bean*.....	RS33
Cookie Dough*.....	RS234
Cream*.....	RS63
Desert Clay*.....	RS19
Esmeralda.....	RS302
Evening Blue.....	RS620
Flamingo.....	RS203
French Vanilla.....	RS66
Ginger*.....	RS51
Golden*.....	RS67
Gravel*.....	RS275
Hazy Lilac*.....	RS310
Honeycomb*.....	RS233
Iceberg.....	RS272
Indigo.....	RS14
Koi.....	RS202
Mineral*.....	RS97
Moon.....	RS277
New Sand*.....	RS20
Night Navy*.....	RS94
Olive*.....	RS02
Peat*.....	RS00
Pompeian Red.....	RS83
Putty.....	RS08
Quicksilver.....	RS30
Rose Red*.....	RS43
Sage.....	RS10
Salsa.....	RS15
Seaweed.....	RS303
Shiitake*.....	RS22
Skyway*.....	RS96
Sterling Blue.....	RS98
Strawberry.....	RS359
Truffle.....	RS12
Turq.....	RS23
White.....	RS47
Wishbone*.....	RS276
Wrought Iron*.....	RS27
Mayer Fabrics CENTRIC	
Blossom.....	WC979-001
Cinnamon.....	WC979-009
Denim.....	WC979-004
Dew.....	WC979-007
Grotto.....	WC979-013
Ink.....	WC979-014
Meadow.....	WC979-003
Mocha.....	WC979-000
Punch.....	WC979-011
Ruby.....	WC979-021
Saffron.....	WC979-002
Shale.....	WC979-006
Mayer Fabrics EDITOR	
Blush.....	WC920-001
Cinder.....	WC920-026
Evergreen.....	WC920-003
Firebrick.....	WC920-011
Grotto.....	WC920-013
Ink.....	WC920-014
Marble.....	WC920-007
Midnight.....	WC920-024
Mineral.....	WC920-006
Mushroom.....	WC920-000
Oatmeal.....	WC920-017
Plumberry.....	WC920-005
Pumice.....	WC920-027
Sandstone.....	WC920-009
Slate.....	WC920-016
Topaz.....	WC920-002
Water.....	WC920-004

GRADE 8 – continued

Camira ZAP	
Argh.....	SCAMZAP11
Awesome.....	SCAMZAP14
Boing.....	SCAMZAP21
Bonza.....	SCAMZAP25
Clang.....	SCAMZAP19
Clobber.....	SCAMZAP12
Cool.....	SCAMZAP30
Crackle.....	SCAMZAP05
Crash.....	SCAMZAP16
Flump.....	SCAMZAP17
Gasp.....	SCAMZAP15
Hahaha.....	SCAMZAP09
Kapow.....	SCAMZAP06
Omg.....	SCAMZAP13
Power.....	SCAMZAP18
Puff.....	SCAMZAP26
Screech.....	SCAMZAP08
Snap.....	SCAMZAP01
Splash.....	SCAMZAP27
Splat.....	SCAMZAP20
Thud.....	SCAMZAP29
Wham.....	SCAMZAP23
Whirr.....	SCAMZAP03
Whomp.....	SCAMZAP28
Whoosh.....	SCAMZAP02
Wowzers.....	SCAMZAP07
Yeah.....	SCAMZAP04
Yikes.....	SCAMZAP10
Zoink.....	SCAMZAP24
Zoom.....	SCAMZAP22

GRADE 9

Mayer Fabrics BELMONT	
Citrus.....	BL-002
Clementine.....	BL-009
Dune.....	BL-017
Gravel.....	BL-000
Opal.....	BL-004
Patina.....	BL-027
Raintree.....	BL-003
Reef.....	BL-014
Sisal.....	BL-007
Stone.....	BL-016
Tidal.....	BL-024
Tundra.....	BL-006
Mayer Fabrics SHIFT	
Almond.....	SH-007
Apricot.....	SH-009
Camel.....	SH-017
Charcoal.....	SH-016
Cranberry.....	SH-008
Cypress.....	SH-003
Metal.....	SH-000
Ocean.....	SH-024
Sapphire.....	SH-034
Silver.....	SH-006
Sky.....	SH-014
Spa.....	SH-004
Mayer Fabrics TRUSS	
Aluminum.....	TS-006
Cadet.....	TS-004
Current.....	TS-001
Ocean.....	TS-003
Persimmon.....	TS-009
Sesame.....	TS-007
Storm.....	TS-016

GRADE 9 – continued

Ultrafabrics ULTRALEATHER PRO	
Aubergine.....	SUF554336
Blue Bird.....	SUF554661
Blueberry.....	SUF554711
Blush.....	SUF554200
Butterfly.....	SUF554216
Butternut*.....	SUF554241
Campfire.....	SUF554229
Capri*.....	SUF554522
Char.....	SUF554626
Chestnut.....	SUF554214
Cloud.....	SUF554648
Coastal.....	SUF554450
Cork.....	SUF554595
Cougar*.....	SUF554209
Cranberry.....	SUF554357
Dark Chocolate.....	SUF554376
Dark Knight.....	SUF554618
Ember.....	SUF554649
Laurel.....	SUF554443
Mortar.....	SUF554733
Parfait.....	SUF554803
Persian Green.....	SUF554453
Rhubarb.....	SUF554329
Sailor.....	SUF554547
Sea Mist.....	SUF554478
Shore.....	SUF554352
Sky.....	SUF554530
Swan.....	SUF554811
Toasted Bagel*.....	SUF554444
Tundra.....	SUF554353
Violet.....	SUF554395
White Wash.....	SUF554008
Woodcres.....	SUF554087
Camira YOREDALE	
Askrigg.....	SCAMYDL03
Buckden.....	SCAMYDL01
Burnsall.....	SCAMYDL22
Carperby.....	SCAMYDL07
Cracoe.....	SCAMYDL23
Cray.....	SCAMYDL10
Dacre.....	SCAMYDL21
Darley.....	SCAMYDL20
Fossdale.....	SCAMYDL11
Gayle.....	SCAMYDL08
Hardraw.....	SCAMYDL04
Kidstone.....	SCAMYDL02
Leyburn.....	SCAMYDL25
Litton.....	SCAMYDL15
Nidd.....	SCAMYDL16
Ribble.....	SCAMYDL17
Ripley.....	SCAMYDL19
Sedbusk.....	SCAMYDL14
Simonstone.....	SCAMYDL05
Thoralby.....	SCAMYDL06
Thornton.....	SCAMYDL09
Walden.....	SCAMYDL13
Warfe.....	SCAMYDL18
Woden.....	SCAMYDL24
Woodale.....	SCAMYDL12
GRADE 10	
Mayer Fabrics CONNECT	
Admiral.....	635-024
Charcoal.....	635-006
Cobalt.....	635-004
Latte.....	635-007
Marine.....	635-014
Meadow.....	635-013
Plum.....	635-005
Spice.....	635-009
Spring.....	635-003

▲ Acuity Jacket Upholstery.

* Colorway not shown on Textiles card; all Partnership Program memo samples are available from supplier. See contact information on page 10.

Allsteel Seating Upholstery Selections by Model/Series, for Social Collaborative see pages 15-16.

		Acuity Jacket	Acuity Seat (for Side-see Relate)	Evo Seat	Evo Upholstered Back	Inspire Back and Seat Pad	Lyric Mesh & Upholstered Seat	Lyric MP	Mimoo Seat	O6	PH	Ped ASPT/SC-Seat Cushions	Involve Approach, Ped YPH & Credenza K-SC Seat Cushions	Relate Upholstered Work	Relate Mesh Back Work	Relate Upholstered Side	Seek	Svelte	Svelte Channel Strich
LEATHER L1																			
Davenport	DAV	•	•	•	•	• ^s	•	•	•	•	•	•	•	•	•	•	•	•	•
Florence	FLOR	•	•	•	•	•	•	•	•	•	•	•	•	•	•	•	•	•	•
Strasbourg	STB			•					•	•								•	•
GRADE 1																			
Apex	APX		•	•	•	•	•	•	•	•	•	•	•	•	•	•	•	•	•
Centurion	CU		•	•	•	•	• ^U	•	•	•	•	•	•	•	•	•	•	•	•
Contourett	UR		•	•	•	•	• ^s		•	•	•	•	•	•	•	•	•	•	•
Dapper	DAPR		•	•	•	•	• ^s	•	•	•	•	•	•	•	•	•	•	•	•
Ensemble	ENSB		•	•		•	•	•	•	•	•	•	•	•	•	•	•	•	•
Hamilton (De-emphasized)	HAML		•	•	•	•	• ^s	•	•	•	•	•	•	•	•	•	•	•	•
Inertia (De-emphasized)	NR		•	•	•	•	• ^s	•	•	•	•	•	•	•	•	•	•	•	•
Optic (De-emphasized)	OP		•	•		•	• ^s	•	•	•	•	• ^s	• ^s	•	•	•	•	•	•
GRADE 2																			
Appoint Seating	PNS		•	•	•	•	• ^s	•	•	•	•	•	•	•	•	•	•	•	•
Blume	BLME		•	•	•	•	•	•	•	•	•	•	•	•	•	•	•	•	•
Clyde	CLYD		•	•	•	•	• ^s	•	•	•	•	•	•	•	•	•	•	•	•
Dotty (De-emphasized)	DOT		•	•		•	• ^s	•	•	•	•	•	•	•	•	•	•	•	•
Meld [⊕]	SMHMMLD		•	•	•	• ^s	• ^s	•	•	•	•	•	•	•	•	•	•	•	•
Rush	RUSH		•	•	•	•	• ^s	•	•	•	•	•	•	•	•	•	•	•	•
Spin Seating	SPNN		•	•		•	• ^s	•	•	•	•	•	•	•	•	•	•	•	•
Taylor (De-emphasized)	TAY		•	•		•	•	•	•	•	•	•	•	•	•	•	•	•	•
Whisper Vinyl	WP		•	•	•	•	• ^s	•	•	•	•	•	•	•	•	•	•	•	•
GRADE 3																			
Lateral [⊕]	SCFSLAT		•	•		•	• ^s	•	•	•	•	• ^s	• ^s	•	•	•	•	•	•
Moxie	SX		•	•	•	•	• ^s	•	•	•	•	•	•	•	•	•	•	•	•
Parker	PRKR		•	•		•	•	•	•	•	•	•	•	•	•	•	•	•	•
Purl	PURL		•	•	•	•	• ^s	•	•	•	•	• ^s	• ^s	•	•	•	•	•	•
Quill	QUL		•	•		•	•	•	•	•	•	•	•	•	•	•	•	•	•
Sydney	456		•	•	•	•	•	•	•	•	•	•	•	•	•	•	•	•	•
GRADE 4																			
Blink	1048		•	•		•	•	•	•	•	•	•	•	•	•	•	•	•	•
Caper [⊕]	SMHMCAP		•	•	•	•	•	•	•	•	•	•	•	•	•	•	•	•	•
Look-See	1044							•	•										
Manner [⊕]	SMHMAN		•	•	•	•	• ^s	•	•	•	•	•	•	•	•	•	•	•	•
Messenger [⊕]	SMHMGRM		•	•	•	•	• ^s	•	•	•	•	•	•	•	•	•	•	•	•
Metric [⊕]	SMHMMET		•	•	•	•	• ^s	•	•	•	•	•	•	•	•	•	•	•	•
Mira	330		•	•	•	•	•	•	•	•	•	•	•	•	•	•	•	•	•
Mode [⊕]	SMHMMOD		•	•	•	•	• ^s	•	•	•	•	•	•	•	•	•	•	•	•
Multiply [⊕]	SMHMMLT		•	•		•	•	•	•	•	•	•	•	•	•	•	•	•	•

^PPed Only

^SSeat Only

^BAvailable only on Banquet

^UAvailable on Upholstered Back

^XNot available on Involve Banquet

[⊕] Partnership Program — See page 10 for details.

~ Available upholstery option only on select colorways.

• Available upholstery option

- Allsteel fabrics and foam meet requirements for CTB117.
- Blank spaces indicate that a product has not yet been tested or that it failed.
- Contact Allsteel Customer Support for other flammability code approvals.

Allsteel Seating Upholstery Selections by Model/Series, for Social Collaborative see pages 15-16.

UPHOLSTERY

Acuity Jacket	Acuity Seat (for Side see Relate)	Evo Seat	Evo Upholstered Back	Inspire Back and Seat Pad	Lyric Mesh & Upholstered Seat	Mimoo Seat	O6	PH	Ped ASPT/SC Seat Cushions	Innovative Approach, Ped YPPH & Credenza KSC Seat Cushions	Relate Upholstered Work	Relate Mesh Back Work	Relate Upholstered Side	Seek	Svelte	Svelte Channel Strich
---------------	-----------------------------------	----------	----------------------	---------------------------	-------------------------------	------------	----	----	---------------------------	--	-------------------------	-----------------------	-------------------------	------	--------	-----------------------

GRADE 4 — continued

Murmur ☺	SMHMMUR															
Muse ☺	SMHMMUS															
Tango	460															
Trundle ☺	SMHMTRN															
Walkabout	1046															

GRADE 5

Checkmate	1043															
Fedora	621															
Main Line Flax ☺	SCAMMLF															
Zip	ZP															
Zippy	1045															

GRADE 6

Arris	ARR															
Balance	BA															
Beaux	366															
Blazer ☺	SCAMBLZ															
Essence	ES															
Hemp	SCAMHMP															
Loop	637															
Poppy	1047															

GRADE 7

Caspian	329															
Curator	WC921															
Silk	SCAMSLK															
Sonnet	ST															

GRADE 8

Apt ☺	SMHMAPT															
Brisa ☺	RS															
Centric	WC979															
Editor	WC920															
Zap	SCAMZAP															

GRADE 9

Belmont	BL															
Shift	SH															
Truss	TS															
Ultraleather Pro ☺	SUF554															
Yoredale	SCAMYDL															

GRADE 10

Connect	635															
---------	-----	--	--	--	--	--	--	--	--	--	--	--	--	--	--	--

^BAvailable only on Banquet

^PPed Only

^SSeat Only

☺ Partnership Program — See page 10 for details.

~ Available upholstery option only on select colorways.

• Available upholstery option

Social Collaborative Standard Upholstery Selections by Model/Series, for all other seating see pages 13-14.

		Clubhouse - Front & Back Back/Storage	Clubhouse - Seating / Consoles	Hedge	Linger Seat	Linger Side	Parallel	Reflect Shell ≠	Reflect Seat & Back	Retreat Exec/Conf Seat	Retreat Exec/Conf Body	Retreat Wing Back Seat	Retreat Wing Back Body	Retreat Hi/Low/Ottoman Seat-Top	Rise Seat	Rise Side	Vicinity Lounge
LEATHER L1																	
Allsteel Leather	WTH																
Florence Leather	FLOR																
Strasburg Leather	STB																
GRADE 1																	
Apex	APX																
Centurion	CU																
Contourett	UR																
Dapper	DAPR																
Hamilton <i>(De-emphasized)</i>	HAM																
Inertia <i>(De-emphasized)</i>	NR																
Noble Seating	SNBLE																
Optic <i>(De-emphasized)</i>	OP																
Vibe	VIBE																
GRADE 2																	
Appoint Seating	PNS																
Blume	BLME																
Clyde	CLYD																
Dotty <i>(De-emphasized)</i>	DOT																
Meld ⚡	SMHMLD																
Rush	RUSH																
Spin Seating	SPNN																
Taylor <i>(De-emphasized)</i>	TAY																
Whisper Vinyl	WP																
GRADE 3																	
Bradbury	BDY																
Lateral ⚡	SCFSLAT																
Notion	NTN																
Parker	PRKR																
Purl	PURL																
Quill	QUL																
Moxie	SX																
Saxony	SXNY																
GRADE 4																	
Blink	1048																
Caper ⚡	SMHMCAP																
Constance w/ Supreen	CNST																
Look-See	1044																
Lugano w/ Supreen	LUG																
Manner ⚡	SMHMMAN																
Messenger ⚡	SMHMGRM																
Metric ⚡	SMHMMET																
Mode ⚡	SMHMMOD																
Multiply ⚡	SMHMMLT																

⚡ Partnership Program — See page 10 for details.

≠ Upholstery will be Railroad cut.

• Available upholstery option

Social Collaborative Standard Upholstery Selections by Model/Series, for all other seating see pages 13-14.

UPHOLSTERY

		Clubhouse - Front & Back Bed/Storage	Clubhouse - Seating / Consoles	Hedge	Linger Seat	Linger Side	Parallel	Reflect Shell ≠	Reflect Seat & Back	Retreat Exec/Conf Seat	Retreat Exec/Conf Body	Retreat Wing Back Seat	Retreat Wing Back Body	Retreat Hi/Low/Ottoman Seat-Top	Rise Seat	Rise Side	Vicinity Lounge
GRADE 4 — continued																	
Murmur ⊕	SMHMMUR				•			•	•	•	•	•	•			•	•
Muse ⊕	SMHMMUS	•	•	•		•	•	•	•	•	•	•	•			•	•
Trundle ⊕	SMHMTRN	•	•	•		•	•			•						•	•
Walkabout	1046	•	•		•	•										•	
GRADE 5																	
Checkmate	1043	•	•		•	•	•	•								•	•
Main Line Flax ⊕	SCAMMLF	•	•	•		•	•		•					•	•	•	•
Zippy	1045	•	•		•	•										•	•
GRADE 6																	
Arris	ARR		•	•	•	•		•	•	•	•	•	•	•	•	•	•
Blazer	SCAMBLZ	•	•	•		•	•	•	•	•	•	•	•			•	•
Poppy	1047	•	•		•	•		•								•	•
GRADE 8																	
Apt ⊕	SMHMAPT	•	•	•	•	•		•	•		•			•		•	•
Brisa ⊕	RS	•	•	•	•	•		•	•	•	•			•	•	•	•
GRADE 9																	
Ultraleather Pro ⊕	SUF554	•	•	•	•	•	•	•	•	•	•			•	•	•	•

⊕ Partnership Program — See page 10 for details.

≠ Upholstery will be Railroad cut.

• Available upholstery option

Refer to pages 13-16 for current upholstery availability by model/series.

GSA Reference Page

LEATHER L1	GRADE 1 – continued	GRADE 1 – continued	GRADE 1 – continued	GRADE 2 – continued
DAVENPORT	CONTOURETT	INERTIA (De-emphasized)	VIBE	KAI
Atlantis DAV02	Baltic.....UR94	Amethyst.....NR61	Bliss.....VIBE03	Algae.....KAI07
Bittersweet.....DAV03	Beach.....UR23	Calypso.....NR98	Calm.....VIBE06	Barnacle.....KAI19
Black.....DAV01	Black.....UR10	Cherry.....NR66	Carefree.....VIBE08	Clownfish.....KAI04
Brown.....DAV14	Bordeaux.....UR63	Cobalt.....NR91	Cheerful.....VIBE17	Coastal.....KAI13
Camel.....DAV13	Buff.....UR22	Coffee.....NR49	Compassion.....VIBE01	Conch.....KAI02
Cream.....DAV11	Cloud.....UR18	Fog.....NR19	Connected.....VIBE13	Coral Reef.....KAI16
Fog.....DAV05	Coffee Bean.....UR49	Fuchsia.....NR63	Content.....VIBE19	Crab.....KAI01
Olive.....DAV09	Crater.....UR51	Gecko.....NR76	Courage.....VIBE12	Ebb.....KAI12
Porcellana.....DAV12	Flame.....UR62	Glow.....NR27	Dazed.....VIBE21	Flow.....KAI11
Red.....DAV16	Graphite.....UR19	Leaf.....NR75	Delight.....VIBE18	Inlet.....KAI03
Rosewood.....DAV10	Iron.....UR20	Lime.....NR82	Euphoria.....VIBE15	Jellyfish.....KAI18
Saddle.....DAV07	Luggage.....UR26	Loft.....NR22	Gleeful.....VIBE04	Kelp.....KAI08
Smoke.....DAV06	Marine.....UR92	Mandarin.....NR47	Gloomy.....VIBE22	Orca.....KAI26
Storm.....DAV08	Navy.....UR95	Meteor.....NR30	Hope.....VIBE07	Otter.....KAI22
Wet Sand.....DAV15	Nimbus.....UR93	Mustard.....NR26	Moody.....VIBE05	Puffer.....KAI06
FLORENCE	Ocean.....UR96	Nickel.....NR23	Nostalgia.....VIBE09	Salty.....KAI23
Almond Biscotti.....FLOR01	Pumpkin.....UR42	Onyx.....NR10	Perplexed.....VIBE10	Seahorse.....KAI05
Basilica.....FLOR12	Quarry.....UR24	Regatta.....NR90	Pride.....VIBE02	Seashell.....KAI20
Duomo.....FLOR10	Red.....UR64	Shadow.....NR20	Relaxed.....VIBE20	Seaweed.....KAI09
Espresso.....FLOR03	Safari.....UR27	Surf.....NR96	Secure.....VIBE16	Shark.....KAI24
Loggia.....FLOR11	Sage.....UR82	Tangelo.....NR46	Serenity.....VIBE11	Shoreline.....KAI21
Lorenzo.....FLOR13	Steel.....UR21	NOBLE SEATING	Trust.....VIBE14	Stingray.....KAI25
Mezza Luna.....FLOR08	Storm.....UR17	Aegean.....SNBLE18	GRADE 2	Tide.....KAI14
Struzzo.....FLOR09	Taupe.....UR28	Amethyst.....SNBLE19	APPOINT SEATING	Turtle.....KAI10
Terra.....FLOR02	Trunk.....UR50	Aspen.....SNBLE14	Artichoke.....PNS014	Urchin.....KAI17
STRASBURG	DAPPER B^w, F^w, S^w, T^w	Aster.....SNBLE20	Blackberry.....PNS012	Wave.....KAI15
Acorn.....STB06	(100% Polyester)	Blossom.....SNBLE21	Bronze.....PNS002	RUSH
Almond.....STB03	Ash.....DAPR20	Bluebell.....SNBLE22	Carbon.....PNS008	(100% Polyester)
Anthracite.....STB21	Breeze.....DAPR06	Bordeaux.....SNBLE01	Chai.....PNS013	Anchor.....RUSH07
Atlantic.....STB19	Canvas.....DAPR25	Brick.....SNBLE02	Cherry.....PNS010	Basil.....RUSH16
Aubergine.....STB08	Charcoal.....DAPR01	Chambray.....SNBLE10	Dark Pewter.....PNS017	Blueberry.....RUSH10
Bark.....STB10	Clover.....DAPR22	Chamomile.....SNBLE23	Dune.....PNS015	Flamingo.....RUSH21
Black.....STB23	Currant.....DAPR00	Clementine.....SNBLE04	Espresso.....PNS003	Greenery.....RUSH15
Bordeaux.....STB15	Fawn.....DAPR35	Conifer.....SNBLE24	Framboise.....PNS011	Greyhound.....RUSH06
Cappuccino.....STB05	Fern.....DAPR85	Cottage.....SNBLE25	Frost.....PNS034	Marina.....RUSH13
Chestnut.....STB07	Gerbera.....DAPR16	Darkness.....SNBLE26	Jet.....PNS007	Merlot.....RUSH19
Cream.....STB02	Grape.....DAPR33	Dawn.....SNBLE13	Lawn.....PNS005	Midnight.....RUSH11
Fir.....STB17	Jewel.....DAPR08	Denim.....SNBLE09	Mandarin.....PNS009	Mint.....RUSH09
Fog.....STB20	Marigold.....DAPR65	Desert Sand.....SNBLE27	Morel.....PNS001	Mulberry.....RUSH18
Fudge.....STB11	Onyx.....DAPR10	Dewfall.....SNBLE28	Nimbus.....PNS016	Pumice.....RUSH01
Graphite.....STB22	Orchid.....DAPR90	Dusted Sage.....SNBLE29	Platinum.....PNS004	Punch.....RUSH20
Ivory.....STB01	Parrot.....DAPR59	Flax.....SNBLE30	Turquoise.....PNS006	Sage.....RUSH14
Black.....STB09	Poppy.....DAPR19	Grass.....SNBLE07	BLUME	Salsa.....RUSH24
Sesame.....STB04	Sapphire.....DAPR07	Gunmetal.....SNBLE15	Chalk.....BLME03	Sand.....RUSH05
GRADE 1	Scarlet.....DAPR45	Harmony.....SNBLE31	Char.....BLME00	Seal.....RUSH08
APEX	Sepia.....DAPR30	Harvest.....SNBLE12	Cher.....BLME04	Soot.....RUSH02
Basalt.....APX25	Sky.....DAPR44	Ice Caves.....SNBLE32	Coin.....BLME02	Stout.....RUSH03
Beet.....APX12	Slate.....DAPR15	Icicle.....SNBLE33	Driftwood.....BLME05	Sunshine.....RUSH23
Blackberry.....APX20	Sorbet.....DAPR55	Inky.....SNBLE34	Emerald City.....BLME07	Tapestry.....RUSH04
Chive.....APX05	Spring.....DAPR80	Iris.....SNBLE35	Fir.....BLME09	Tiger.....RUSH22
Iris.....APX03	Terracotta.....DAPR13	Jade.....SNBLE06	Harvest.....BLME04	Vintage.....RUSH17
Kiwi.....APX06	Titanium.....DAPR17	Knight.....SNBLE17	Haze.....BLME08	Wave.....RUSH12
Lemonade.....APX08	Varsity.....DAPR09	Mesa.....SNBLE03	Hyacinth.....BLME14	SPIN SEATING
Navy.....APX13	Zest.....DAPR70	Monarch.....SNBLE36	Jasper.....BLME13	(51% Polyester, 49% Recycled Polyester)
Papaya.....APX09	ENSEMBLE	Pacific.....SNBLE08	Merlot.....BLME10	Alabaster.....SPNN02
Pumice.....APX23	Aquamarine.....ENSB30	Pitch.....SNBLE37	Moonstone.....BLME01	Cavern.....SPNN03
Rain.....APX19	Ash.....ENSB39	Queen Bee.....SNBLE38	Opal.....BLME06	Cobblestone.....SPNN04
Resort.....APX15	Greige.....ENSB36	Rainforest.....SNBLE05	Scarlet.....BLME11	Ember.....SPNN06
Royal.....APX14	Harbor.....ENSB34	Regal.....SNBLE11	Slate.....BLME12	Flame.....SPNN07
Tiki.....APX29	Navy.....ENSB35	Sandcastle.....SNBLE39	CLYDE	Heron.....SPNN13
Tomato.....APX11	Oat.....ENSB37	Sedona.....SNBLE40	Antique.....CLYD04	Oat.....SPNN01
CENTURION B, C, F, O, S, T	Pear.....ENSB33	Stormy.....SNBLE16	Artifact.....CLYD01	Ocean.....SPNN12
(Nanotex™ Stain-Resistant finish)	Sand.....ENSB38	Subbeam.....SNBLE41	Blacksmith.....CLYD10	Plum.....SPNN15
Apricot.....CU47	Scarlet.....ENSB32	Voyager.....SNBLE42	Claret.....CLYD13	Pool.....SPNN11
Bark.....CU25	Slate.....ENSB31	Windy Day.....SNBLE43	Craftsman.....CLYD08	Raven.....SPNN10
Black.....CU10	Stone.....ENSB40	OPTIC (De-emphasized)	Crate.....CLYD12	Rhubarb.....SPNN14
Espresso.....CU49	HAMILTON (De-emphasized)	Aurora.....OP72	Fossil.....CLYD02	Tropic.....SPNN08
Fog.....CU03	(100% Polyester)	Bark.....OP24	Heirloom.....CLYD05	Willow.....SPNN05
Frost.....CU22	Azure.....HAML10	Canopy.....OP84	Iron.....CLYD11	
Goldenrod.....CU27	Biscotti.....HAML11	Char.....OP49	Keepsake.....CLYD15	
Indigo.....CU06	Cabernet.....HAML08	Ruby.....OP42	Linen.....CLYD14	
Iris.....CU50	Carolina.....HAML21	Sand.....OP17	Relic.....CLYD06	
Iron Ore.....CU19	Charcoal.....HAML17	Sky.....OP83	Seasoned.....CLYD03	
Jade.....CU83	Chocolate.....HAML13	Slate.....OP19	Trestle.....CLYD07	
Marsala.....CU63	Cloud.....HAML18	Sprout.....OP74	DOTTY (De-emphasized)	
Morel.....CU24	Dane.....HAML16	Starry Night.....OP11	(100% Polyester)	
Navy.....CU98	Dusty Rose.....HAML07	Storm.....OP56	Candy.....DOT63	
Peacock.....CU97	Esmeralda.....HAML06	Wildfire.....OP66	Gelato!.....DOT34	
Pear.....CU84	Fern.....HAML04		Indigo.....DOT31	
Ruby.....CU67	Fresh.....HAML03		Onyx.....DOT35	
Sapphire.....CU09	Granola.....HAML19		Park.....DOT83	
	Lilac.....HAML14		Peat.....DOT24	
	Lime.....HAML05		Peony.....DOT32	
	Lipstick.....HAML09		Suit.....DOT20	
	Oxford.....HAML20		Sunflower.....DOT33	
	Passion Fruit.....HAML02		Tailor.....DOT21	
	Pepper.....HAML15		Tide.....DOT90	
	Powder.....HAML12		Velum.....DOT29	
	Sunrise.....HAML01		Violet.....DOT30	
Note: See pages 10-12 for listing and explanation of Partnership Program upholstery.				

UPHOLSTERY

▲ Acuity Jacket Upholstery
Multi-use fabrics are noted with the following designators:
B – Tackboards S – Stride®
C – Concensys® T – Terrace®
O – Optimize™ F – Further™
* limited to 48" W or less

Refer to pages 13-16 for current upholstery availability by model/series.

UPHOLSTERY

GRADE 2 – continued

TAYLOR (De-emphasized) (74% Post-Consumer Recycled Polyester, 26% Polyester)

Autumn	TAY43
Daffodil	TAY20
Deep Lilac	TAY75
Dreamy	TAY80
Envious	TAY58
Handkerchief	TAY90
Luxe	TAY50
Malbec	TAY40
Martini	TAY60
Mink	TAY30
Pearl	TAY15
Spritz	TAY45
Tungsten	TAY85

WAVELENGTH

Base	WVL21
Crest	WVL14
Cycle	WVL20
Energy	WVL03
Frequency	WVL04
Infrared	WVL01
Motion	WVL13
Movement	WVL05
Peak	WVL11
Pressure	WVL06
Shallow	WVL02
Still	WVL07
Surface	WVL18
Surge	WVL10
Swell	WVL08
Tide	WVL16
Transition	WVL15
Trough	WVL19
Tsunami	WVL09
Ultraviolet	WVL12
White Caps	WVL17

WHISPER VINYL

Antelope	WP20
Black	WP40
Bone	WP17
Camel	WP18
Cappuccino	WP21
Cashew	WP29
Cerulean	WP36
Charcoal	WP39
Cinnamon	WP25
Cognac	WP62
Elephant	WP38
Espresso	WP49
Fawn	WP91
Indigo	WP86
Mahogany	WP93
Mallard	WP90
Navy	WP37
Patina	WP34
Pewter	WP83
Salsa	WP42
Storm	WP92
Truffle	WP95

GRADE 3

BRADBURY

Acorn	BDY01
Alabaster	BDY02
Aspire	BDY03
Blueberry	BDY04
Carbon	BDY05
Concord	BDY06
Cozumel	BDY07
Dolphin	BDY08
Gala	BDY09
Honey	BDY10
Mushroom	BDY11
Mystic	BDY12
Oat	BDY13
Rhino	BDY14
Scallion	BDY15
Sidewalk	BDY16
Terrazzo	BDY17
Vellum	BDY18
Walnut	BDY19

GETAWAY

Brig	GTWY15
Canoe	GTWY03
Catamaran	GTWY08
Cruise Ship	GTWY10
Cuddy	GTWY01
Ferry	GTWY11
Gondola	GTWY02
Jet Ski	GTWY09
Kayak	GTWY05
Pontoon	GTWY13
Runabout	GTWY14
Sailboat	GTWY07
Speedboat	GTWY12
Wakeboard	GTWY06
Yacht	GTWY04

NOTION

Agave	NTN01
Bark	NTN02
Beeswax	NTN03
Carbon	NTN04
Cassiss	NTN05
Cement	NTN06
Char	NTN07
Chroma	NTN08
Dockside	NTN09
Drifter	NTN10
Fog	NTN11
Foundation	NTN12
Fox	NTN13
Grassland	NTN14
Henna	NTN15
Horizon	NTN16
Ivy	NTN17
Linen	NTN18
Mykonos	NTN19
Peat	NTN20
Poppy	NTN21
Rockfall	NTN22
Sandwash	NTN23
Stoneware	NTN24
Sumac	NTN25
Twilight	NTN26

PARKER

Aloe	PRKR01
Cumulus	PRKR05
Cyan	PRKR06
Domino	PRKR07
Fossil	PRKR10
Graphite	PRKR11
Grass	PRKR12
Grenadine	PRKR13
Griffin	PRKR14
Kiln	PRKR16
Magnesium	PRKR18
Magnet	PRKR19
Mica	PRKR20
Mink	PRKR21
Nightfall	PRKR22
Paprika	PRKR24
Pine	PRKR25
Rapids	PRKR28
Rioja	PRKR30

GRADE 3 – continued

PURL

(80% Polyester, 20% Acrylic)

Alpaca	PURL08
Braid	PURL10
Deep	PURL12
Graze	PURL05
Loom	PURL06
Needle	PURL07
Pasture	PURL02
Ranch	PURL04
Shuttle	PURL09
Skein	PURL01
Thisle	PURL11
Yearling	PURL03

QUILL

Aviary	QUL03
Feather	QUL02
Fountain	QUL06
Ink	QUL05
Metal	QUL04
Reed	QUL08
Scroll	QUL01
Well	QUL07

MOXIE

Barnwood	SX09
Basalt	SX23
Bayou	SX02
Bermuda	SX52
Biscotti	SX08
Blackberry	SX48
Blarney	SX49
Blueberry	SX05
Bonsai	SX20
Brigade	SX53
Butterscotch	SX54
Carob	SX24
Chalk	SX50
Chartreuse	SX34
Cherry	SX38
Cinnamon	SX13
Cobalt	SX01
Coconut	SX06
Concrete	SX43
Cozumel	SX55
Cumin	SX32
Dragonfly	SX44
Dover	SX56
Earl Grey	SX40
Elysian	SX04
Evergreen	SX21
Fatigue	SX18
Fawn	SX30
Flint	SX39
Forsythia	SX57
Grenache	SX58
Hazel	SX31
Hemp	SX45
Hickory	SX25
Holly	SX51
Jam	SX16
Kelly	SX33
Lemongrass	SX19
Lime	SX41
Macintosh	SX12
Midnight	SX59
Mulberry	SX15
Muslin	SX60
Pacifica	SX61
Parchment	SX07
Peacock	SX03
Phantom	SX62
Pineapple	SX42
Plum	SX17
Punch	SX46
Riverstone	SX47
Russet	SX14
Smokestack	SX22
Tangerine	SX37
Terracotta	SX11
Thicket	SX35
Walnut	SX10
Whirlwind	SX63

GRADE 3 – continued

SAXONY

Arctic	SXNY14
Azure	SXNY11
Black	SXNY21
Clover	SXNY06
Cobalt	SXNY12
Emerald	SXNY08
Flare	SXNY02
Fog	SXNY18
Grass	SXNY05
Iron	SXNY20
Lagoon	SXNY07
Lipstick	SXNY01
Mandarin	SXNY03
Navy	SXNY13
Sand	SXNY16
Sea	SXNY10
Shell	SXNY15
Sky	SXNY09
Storm Cloud	SXNY19
Taupe	SXNY17
Zest	SXNY04

GRADE 4

CONSTANCE WITH SUPREEN

Airy	CNST01
Aztec	CNST02
Cassiss	CNST03
Copperplate	CNST04
Cornerstone	CNST05
Envy	CNST06
Flagstone	CNST07
Flax	CNST08
Frost	CNST09
Gateway	CNST10
Grounds	CNST11
Hayfield	CNST12
Inkpad	CNST13
Pewter	CNST14
Pistachio	CNST15
Pompeii	CNST16
Poseidon	CNST17
Reflection	CNST18
Scuba	CNST19
Stoic	CNST20
Stonington	CNST21
Thunder	CNST22
Waterfall	CNST23

LIVI

Asphalt	LIVI01
Atlantis	LIVI02
Bouquet	LIVI03
Branch	LIVI04
Coastal	LIVI05
Cowboy	LIVI06
Dawn	LIVI07
Earth	LIVI09
Evergreen	LIVI10
Fennel	LIVI11
Fog	LIVI12
Honeycomb	LIVI13
Jade	LIVI14
Limestone	LIVI15
Monochrome	LIVI16
Night	LIVI17
Overcast	LIVI18
Pebble	LIVI19
Pillow	LIVI08
Plum	LIVI20
Pumpkin	LIVI21
Rhubarb	LIVI22
Saxon	LIVI23
Seaside	LIVI24
Twine	LIVI25

GRADE 4 – continued

LUGANO WITH SUPREEN

Andromeda	LUG01
Aquarelle	LUG02
Bayou	LUG03
Caviar	LUG04
Cloud	LUG05
Cobblestone	LUG06
Dutch	LUG07
Flirt	LUG08
Florence	LUG09
Frost	LUG10
Ganache	LUG11
Gravel	LUG12
Juniper	LUG13
Lapis	LUG14
Moonstone	LUG15
Mustard Seed	LUG16
Sandstone	LUG17
Sconce	LUG18
Semolina	LUG19
Spice Market	LUG20
Sterling	LUG21

OXFORD

Armor	OXFD01
Azurite	OXFD02
Cadet	OXFD03
Cider	OXFD04
Clover	OXFD05
Coal	OXFD16
Coin	OXFD06
Crema	OXFD07
Currant	OXFD08
Deluge	OXFD09
Dewberry	OXFD10
Falcon	OXFD11
Gingerbread	OXFD12
Laurel	OXFD13
Odyssey	OXFD14
Pavement	OXFD15
Redvine	OXFD17
Seadrift	OXFD18
Shoji	OXFD19
Tourmaline	OXFD20
Vignette	OXFD21

GRADE 6

ARRIS

Artisan	ARR01
Baroque	ARR02
Noble	ARR02
Rattan	ARR05
Rich	ARR04
Tapestry	ARR03
Weft	ARR06

▲ Acuity Jacket Upholstery
Multi-use fabrics are noted with the following designators:
B – Tackboards S – Stride®
C – Concensys® T – Terrace®
O – Optimize™ F – Further™

Note: See pages 10-12 for listing and explanation of Partnership Program upholsteries.

Refer to pages 13-16 for current upholstery availability by model/series.

MESH

ACUITY® MESH

Clay	C
Mist	M
Dusk	D
Navy	N
Lustre	L

CLARITY® & RELATE® MESH

Carbon**	LKM01
Platinum	CM23
Flint*	CM20
Graphite*	CM22

*Not available on Relate

**Not available on Clarity

MIMEO™ MESH

Amethyst	NM61
Cobalt	NM91
Fog	NM19
Glow	NM27
Leaf	NM75
Loft	NM22
Onyx	NM10
Shadow	NM20

QUIP™ MESH

Carbon	SBM01
Graphite	SBM22
Lime	SBM30
Loft	SBM03
Navy	SBM28
Poppy	SBM25

SEEK® MESH

Dusk Only

SPECTRUM* MESH

Beacon	RM27
Blueberry	RM20
Brick	RM16
Bullseye	RM17
Carbon	RM10
Chalk	RM28
Cobalt	RM14
Espresso	RM15
Gold Dust	RM31
Kermit	RM23
Key Lime	RM32
Leaf	RM21
Linen	RM30
Loft	RM12
Midnight	RM24
Onyx	RM13
Pear	RM29
Quicksand	RM33
Salamander	RM25
Sky	RM19
Steel	RM26
Titanium	RM11

*Only available on O6.

INSPIRE, SEEK

and NIMBLE

POLYMER COLORS

Black (formerly Onyx)	BLK
Brownstone	BW
Cayenne	RD
Sprout	GN
Summit	GY
Surf	BU
Tangelo	RG
White (formerly Frost)	WT

VICINITY

POLYMER COLORS

Brownstone	BW
Calypso	CP
Cherry	CR
Lava	LA
Regatta	RE
Titanium	TI
White	WT
Zest	ZE

Note: See pages 10-12 for listing and explanation of Partnership Program upholstery.

▲ Acuity Jacket Upholstery

Multi-use fabrics are noted with the following designators:

B – Tackboards	S – Stride®
C – Concensys®	T – Terrace®
O – Optimize™	F – Further™

Seating

- Available upholstery option
- RR: railroaded, F/FR: Fire compliant model

UPHOLSTERY

Pattern Name	Code	Supplier	Grade	Acuity Arms	Acuity Back Jacket	Acuity Seat	Acuity Side (Mesh)	CoHo (MDS 10280)	Evo Seat (MDS 10259)	Evo Upholstered Back (MDS 10259)	Inspire Back
Parker	1054	HBF Textiles	3			•	•		•	•	
Blink	1048	HBF Textiles	4			•	•				•
Look-See	1044	HBF Textiles	4			•	•	•	•	•	
Walkabout	1046	HBF Textiles	4			•	•		•		
Against the Grain	AGG	HBF Textiles	5			F	F	•	•		F
Caddy Corner	1016	HBF Textiles	5			•	•	•	•	•	•
Checkmate	1043	HBF Textiles	5			•	•	•	•	•	•
Pebbled	SHBFPEB	HBF Textiles	5			•	•		•	•	
Picnic Plaid	1029	HBF Textiles	5			•	•		•		
Upbeat	1036	HBF Textiles	5			•	•		•		•
Zippy	1045	HBF Textiles	5			•	•	•	•	•	•
Poppy	1047	HBF Textiles	6			•	•	•	•	•	•
Crew Cut	SHBFCRW	HBF Textiles	7			•	•		•		
Happy Camper	1028	HBF Textiles	7			•	•	•	•	•	•
Honest	SHBFHON	HBF Textiles	7			•	•	•	•	•	
Roundabout	1005	HBF Textiles	7			•	•		•		•
Beetle	SHBFBEE	HBF Textiles	8			•	•		•	•	•
Dashing	1008	HBF Textiles	8			•	•		•		•
Fourfold	SHBFFOU	HBF Textiles	8			•	•		•		•
Modern Tweed	SHBFMOD	HBF Textiles	8			•	•	•	•		
Sherpa	1031	HBF Textiles	8			•	•	•	•	•	•
All Terrain	1027	HBF Textiles	9			•	•	•	•	•	•
Comfort Zone	905	HBF Textiles	9			•	•		•		
Crafted Felt	1017	HBF Textiles	9			•	•	•	•	•	•
Curtain Wall	1023	HBF Textiles	9			•	•		•		•
High Rise	SHBFHIG	HBF Textiles	9			•	•		•		
Madam Dottie	1001	HBF Textiles	9			•	•	•	•	•	•
Scribble XS	982	HBF Textiles	9			•	•		•	•	•
Uptown	1039	HBF Textiles	9			•	•	•	•	•	•
Wabi Sabi	SHBFWAB	HBF Textiles	9			•	•	•	•	•	•
Color Code	998	HBF Textiles	10			•	•		•		
Digital Bloom 2.0	1050	HBF Textiles	10			•	•	•	•	•	•
Equation	SHBFQU	HBF Textiles	10			F	F	•	•	•	F
Folded Lines	973	HBF Textiles	10			•	•	•	•		•
Remember	SHBFREM	HBF Textiles	10								
Roy's Cords	1025	HBF Textiles	10			•	•				
Soft Angles 2.0	1051	HBF Textiles	10			•	•	•	•		
Upscale	1040	HBF Textiles	10			•	•		•	•	•
Air Mail	1006	HBF Textiles	11			•	•		•		•
Argyle Boucle	978	HBF Textiles	11			•	•	•	•	•	•
Brushed Canvas	SHBFBCV	HBF Textiles	11			•	•		•	•	
Cloud	SHBFCLD	HBF Textiles	11			•	•		•		
Abito	ABI	HBF Textiles	12			•	•	•	•	•	•
Belgian Meadow	SHBFBLM	HBF Textiles	12			•	•	•	•	•	•
Complex	964	HBF Textiles	12			•	•	•	•	•	•
Crosstweed	991	HBF Textiles	12			•	•	•	•	•	•
Cutout	SHBFCUT	HBF Textiles	12			•	•		•		•
Dot Grid	975	HBF Textiles	12			•	•		•		•
Dot Structure	SHBFDOT	HBF Textiles	12			•	•	•	•	•	•
Glint	SHBFGLT	HBF Textiles	12			•	•		•		•
Grateful Grid	1015	HBF Textiles	12			•	•	•	•	•	•
Heartfelt	SHBFHTF	HBF Textiles	12			F	F	•	•	•	F
Lava Rock	993	HBF Textiles	12			•	•	•	•	•	•
Merci Boucle	SHBFMER	HBF Textiles	12			•	•	•	•	•	•
Moving Blanket	SHBFMOV	HBF Textiles	12			•	•		•		
Sable Island	SHBFSAB	HBF Textiles	12			•	•		•		
Sir Stripe A Lot	1004	HBF Textiles	12			•	•		•		•

Seating

- Available upholstery option
- RR: railroaded, F/FR: Fire compliant model

Pattern Name	Code	Supplier	Grade	Acuity Arms	Acuity Back Jacket	Acuity Seat	Acuity Side (Mesh)	CoHo (MDS 10280)	Evo Seat (MDS 10259)	Evo Upholstered Back (MDS 10259)	Inspire Back
Sweater Weather	1030	HBF Textiles	12			•	•	•	•		•
Twist	SHBFTWS	HBF Textiles	12			•	•		•		•
Upstart	1042	HBF Textiles	12			•	•		•		•
Cherished Knit	954	HBF Textiles	13			•	•	•	•	•	•
Enriched Boucle	1021	HBF Textiles	13			•	•	•	•	•	•
Foundation	SHBFFND	HBF Textiles	13								
Moving Forward	1014	HBF Textiles	13			•	•	•	•		•
Night Earth	1013	HBF Textiles	13			•	•	•	•		•
Pepper Blend	995	HBF Textiles	13			•	•	•	•		•
Quill	1011	HBF Textiles	13			•	•	•	•		•
Scribble XL	983	HBF Textiles	13			•	•		•		•
Sister Solid	1003	HBF Textiles	13			•	•	•	•		•
Afghan	AFG	HBF Textiles	14			F	•		•		
Smart	SHBFSMT	HBF Textiles	14			•	•	•	•		
Velvet Mix	977	HBF Textiles	14			•	•		•		•
Hipster	SHBFHPT	HBF Textiles	15			F	F	•	•		F
Landscape Blur	1024	HBF Textiles	15			•	•	•	•		•
Poodle	1009	HBF Textiles	16			•	•	•	•		•
Sweater	SHBFSWE	HBF Textiles	16					•	•	•	
Woven Memory	1019	HBF Textiles	16			•	•		•		•
Crafted Cloud	1018	HBF Textiles	19			•	•	•	•		
Knitwork	SHBFKNI	HBF Textiles	21			•	•		•	•	F
Bunny	1012	HBF Textiles	23			•	•	•	•	•	•
Eccentric	966	HBF Textiles	23			•	•		•		
Eccentric	SHBFEC	HBF Textiles	23			•	•		•		
Wild West	717	HBF Textiles	L2			•	•		•		•
Aviator	SHBFAVI	HBF Textiles	L3			•					
Free Way	SHBFFRE	HBF Textiles	L3			•	•		•		•
Modern Patina	716	HBF Textiles	L3			•	•		•		•
Persuede	718	HBF Textiles	L3			•	•		•		•
Vivace II	709	HBF Textiles	L3			•	•	•	•		F
Upper Crust	708	HBF Textiles	L5			•	•	•	•		F
Voyage	713	HBF Textiles	L5			•	•	•	•		F

UPHOLSTERY

Seating

ASI Product Fabric Matrix

GSA Reference Page

- Available upholstery option
- RR: railroaded, F/FR: Fire compliant model

UPHOLSTERY

Pattern Name	Code	Supplier	Grade	Inspire Seat	Involve Soft Seating	Involve Approach, and YPPA / K5CT Ped Topper	Lyric Uph. Seat (CWW-, CLL-, CSC-, CSS-)	Lyric Upholstered Back	Lyric MP (CMPNU-, CMPWU-, CSWU-, Mimeo)	Radii Ped Topper	Relate Mesh Task	Relate Mesh Side	Relate Uph Task
Parker	1054	HBF Textiles	3										
Blink	1048	HBF Textiles	4	•	•	•	•	•	•	•	•	•	•
Look-See	1044	HBF Textiles	4		•	•	•	•	•	•	•	•	•
Walkabout	1046	HBF Textiles	4		•	•	•	•	•	•	•	•	•
Against the Grain	AGG	HBF Textiles	5	F	•	•	F	F	•	F	F	F	F
Caddy Corner	1016	HBF Textiles	5	•	•	•	•	•	•	•	•	•	•
Checkmate	1043	HBF Textiles	5	•	•	•	•	•	•	•	•	•	•
Pebbled	SHBFPEB	HBF Textiles	5				•			•	•	•	•
Picnic Plaid	1029	HBF Textiles	5		•	•	•	•	•	•	•	•	•
Upbeat	1036	HBF Textiles	5	•	•	•	•	•	•	•	•	•	•
Zippy	1045	HBF Textiles	5	•	•	•	•	•	•	•	•	•	•
Poppy	1047	HBF Textiles	6	•	•	•	•	•	•	•	•	•	•
Crew Cut	SHBFCRW	HBF Textiles	7		•	•	•	•	•	•	•	•	•
Happy Camper	1028	HBF Textiles	7	•	•	•	•	•	•	•	•	•	•
Honest	SHBFHON	HBF Textiles	7		•	•	•	•	•	•	•	•	•
Roundabout	1005	HBF Textiles	7	•	•	•	•	•	•	•	•	•	•
Beetle	SHBFBEE	HBF Textiles	8	•	•	•	•	•	•	•	•	•	•
Dashing	1008	HBF Textiles	8	•	•	•	•	•	•	•	•	•	•
Fourfold	SHBFFOU	HBF Textiles	8	•			•			•	•	•	•
Modern Tweed	SHBFMOD	HBF Textiles	8		•	•	•	•	•	•	•	•	•
Sherpa	1031	HBF Textiles	8	•	•	•	•	•	•	•	•	•	•
All Terrain	1027	HBF Textiles	9	•	•	•	•	•	•	•	•	•	•
Comfort Zone	905	HBF Textiles	9		•	•	•	•	•	•	•	•	•
Crafted Felt	1017	HBF Textiles	9	•	•	•	•	•	•	•	•	•	•
Curtain Wall	1023	HBF Textiles	9	•	•	•	•	•	•	•	•	•	•
High Rise	SHBFHIG	HBF Textiles	9		•	•	•	•	•	•	•	•	•
Madam Dottie	1001	HBF Textiles	9	•	•	•	•	•	•	•	•	•	•
Scribble XS	982	HBF Textiles	9	•	•	•	•	•	•	•	•	•	•
Uptown	1039	HBF Textiles	9	•	•	•	•	•	•	•	•	•	•
Wabi Sabi	SHBFWAB	HBF Textiles	9		•	•	•	•	•	•	•	•	•
Color Code	998	HBF Textiles	10		•	•	•	•	•	•	•	•	•
Digital Bloom 2.0	1050	HBF Textiles	10	•	•	•	•	•	•	•	•	•	•
Equation	SHBFEQU	HBF Textiles	10	F	F	F	F	F	•	F	F	F	F
Folded Lines	973	HBF Textiles	10	•	•	•	•	•	•	•	•	•	•
Remember	SHBFREM	HBF Textiles	10			•				•			
Roy's Cords	1025	HBF Textiles	10		•	•	•	•	•	•	•	•	•
Soft Angles 2.0	1051	HBF Textiles	10		•	•	•	•	•	•	•	•	•
Upscale	1040	HBF Textiles	10	•	•	•	•	•	•	•	•	•	•
Air Mail	1006	HBF Textiles	11	•	•	•	•	•	•	•	•	•	•
Argyle Boucle	978	HBF Textiles	11	•	•	•	•	•	•	•	•	•	•
Brushed Canvas	SHBFBCV	HBF Textiles	11		•	•	•	•	•	•	•	•	•
Cloud	SHBFCLD	HBF Textiles	11		•					•	•		
Abito	ABI	HBF Textiles	12	•	•	•	•	•	•	•	•	•	•
Belgian Meadow	SHBFBLM	HBF Textiles	12	•	•	•	•	•	•	•	•	•	•
Complex	964	HBF Textiles	12	•	•	•	•	•	•	•	•	•	•
Crosstweed	991	HBF Textiles	12	•	•	•	•	•	•	•	•	•	•
Cutout	SHBFCUT	HBF Textiles	12	•	•	•	•	•	•	•	•	•	•
Dot Grid	975	HBF Textiles	12	•	•	•	•	•	•	•	•	•	•
Dot Structure	SHBFDOT	HBF Textiles	12	•	•	•	•	•	•	•	•	•	•
Glint	SHBFGLT	HBF Textiles	12	•	•	•	•	•	•	•	•	•	•
Grateful Grid	1015	HBF Textiles	12	•	•	•	•	•	•	•	•	•	•
Heartfelt	SHBFHTF	HBF Textiles	12	F	F	F	F	F	•	F	F	F	F
Lava Rock	993	HBF Textiles	12	•	•	•	•	•	•	•	•	•	•
Merci Boucle	SHBFMER	HBF Textiles	12		•	•	•	•	•	•	•	•	•
Moving Blanket	SHBFMOV	HBF Textiles	12		•	•	•	•	•	•	•	•	•
Sable Island	SHBFSAB	HBF Textiles	12		•	•	•	•	•	•	•	•	•
Sir Stripe A Lot	1004	HBF Textiles	12	•	•	•	•	•	•	•	•	•	•

Seating

- Available upholstery option
- RR: railroaded, F/FR: Fire compliant model

Pattern Name	Code	Supplier	Grade	Inspire Seat	Involve Soft Seating	Involve, Approach, K5CT Ped Toppers	Lyric Uph. Seat (YPPA / CSC, CSS,)	Lyric Upholstered Back	Lyric MP (CMPNU, CWS30U,)	Mimeo	Radii Ped Topper	Relate Mesh Task	Relate Mesh Side	Relate Uph Task
Sweater Weather	1030	HBF Textiles	12	•	•	•	•	•	•	•	•	•	•	•
Twist	SHBFTWS	HBF Textiles	12	•	•	•	•	•	•	•	•	•	•	•
Upstart	1042	HBF Textiles	12	•	•	•	•	•	•	•	•	•	•	•
Cherished Knit	954	HBF Textiles	13	•	•	•	•	•	•	•	•	•	•	•
Enriched Boucle	1021	HBF Textiles	13	•	•	•	•	•	•	•	•	•	•	•
Foundation	SHBFFND	HBF Textiles	13											
Moving Forward	1014	HBF Textiles	13	•	•	•	•	•	•	•	•	•	•	•
Night Earth	1013	HBF Textiles	13	•	•	•	•	•	•	•	•	•	•	•
Pepper Blend	995	HBF Textiles	13	•	•	•	•	•	•	•	•	•	•	•
Quill	1011	HBF Textiles	13	•	•	•	•	•	•	•	•	•	•	•
Scribble XL	983	HBF Textiles	13	•	•	•	•	•	•	•	•	•	•	•
Sister Solid	1003	HBF Textiles	13	•	•	•	•	•	•	•	•	•	•	•
Afghan	AFG	HBF Textiles	14		•	•	•			•	•	•	•	•
Smart	SHBFSMT	HBF Textiles	14		•	•	•			•	•	•	•	•
Velvet Mix	977	HBF Textiles	14	•	•	•	•	•	•	•	•	•	•	•
Hipster	SHBFHPT	HBF Textiles	15	F	F	F	F	F		•	F	F	F	F
Landscape Blur	1024	HBF Textiles	15	•	•	•	•	•	•	•	•	•	•	•
Poodle	1009	HBF Textiles	16	•	•	•	•	•	•	•	•	•	•	•
Sweater	SHBFSWE	HBF Textiles	16											
Woven Memory	1019	HBF Textiles	16	•	•	•	•	•	•	•	•	•	•	•
Crafted Cloud	1018	HBF Textiles	19		•	•	•	•	•	•	•	•	•	•
Knitwork	SHBFKNI	HBF Textiles	21	F	•	•	•	F		•	•	•	•	•
Bunny	1012	HBF Textiles	23	•	•	•	•	•	•	•	•	•	•	•
Eccentric	966	HBF Textiles	23		•	•	•			•	•	•		
Eccentric	SHBFEC	HBF Textiles	23		•	•	•			•	•	•		
Wild West	717	HBF Textiles	L2	•			•	•			•	•		
Aviator	SHBFAVI	HBF Textiles	L3											
Free Way	SHBFFRE	HBF Textiles	L3	•		•		•			•	•	•	•
Modern Patina	716	HBF Textiles	L3	•		•		•			•	•		
Persuede	718	HBF Textiles	L3	•		•		•			•	•		
Vivace II	709	HBF Textiles	L3	F		•		F			F	F		
Upper Crust	708	HBF Textiles	L5	F		•		F			F	F		
Voyage	713	HBF Textiles	L5	F		•		F			F	F		

UPHOLSTERY

Seating

- Available upholstery option
- RR: railroaded, F/FR: Fire compliant model

UPHOLSTERY

Pattern Name	Code	Supplier	Grade	Relate Uph Side	Seek	Soothe Back/ Single Fabric	Soothe Seat	Soothe High Back Back/ Single Fabric	Soothe High Back Seat	Stride and ASP7/ZSC Ped Toppers	Svelte	Svelte Channel Stitch
Parker	1054	HBF Textiles	3	•	•	•	•					
Blink	1048	HBF Textiles	4	•	•	•	•					
Look-See	1044	HBF Textiles	4	•	•	•	•					
Walkabout	1046	HBF Textiles	4	•	•	•	•					
Against the Grain	AGG	HBF Textiles	5	F	•					F		
Caddy Corner	1016	HBF Textiles	5	•	•							
Checkmate	1043	HBF Textiles	5	•	•	•	•					
Pebbled	SHBFPEB	HBF Textiles	5	•	•							
Picnic Plaid	1029	HBF Textiles	5	•	•							
Upbeat	1036	HBF Textiles	5	•	•							
Zippy	1045	HBF Textiles	5	•	•	•	•					
Poppy	1047	HBF Textiles	6	•	•	•	•					
Crew Cut	SHBFRCRW	HBF Textiles	7		•							
Happy Camper	1028	HBF Textiles	7	•	•							
Honest	SHBFHON	HBF Textiles	7		•							
Roundabout	1005	HBF Textiles	7	•	•							
Beetle	SHBFBEE	HBF Textiles	8		•							
Dashing	1008	HBF Textiles	8	•	•							
Fourfold	SHBFFOU	HBF Textiles	8	•	•							
Modern Tweed	SHBFMOD	HBF Textiles	8	•	•							
Sherpa	1031	HBF Textiles	8	•	•							
All Terrain	1027	HBF Textiles	9	•	•							
Comfort Zone	905	HBF Textiles	9									
Crafted Felt	1017	HBF Textiles	9	•	•							
Curtain Wall	1023	HBF Textiles	9	•	•							
High Rise	SHBFHIG	HBF Textiles	9	•	•							
Madam Dottie	1001	HBF Textiles	9	•	•							
Scribble XS	982	HBF Textiles	9	•	•							
Uptown	1039	HBF Textiles	9	•	•							
Wabi Sabi	SHBFWAB	HBF Textiles	9		•							
Color Code	998	HBF Textiles	10	•	•							
Digital Bloom 2.0	1050	HBF Textiles	10		•							
Equation	SHBFEQU	HBF Textiles	10	F	•					F		
Folded Lines	973	HBF Textiles	10	•	•							
Remember	SHBFREM	HBF Textiles	10									
Roy's Cords	1025	HBF Textiles	10									
Soft Angles 2.0	1051	HBF Textiles	10		•							
Upscale	1040	HBF Textiles	10	•	•							
Air Mail	1006	HBF Textiles	11	•	•							
Argyle Boucle	978	HBF Textiles	11	•	•							
Brushed Canvas	SHBFBCV	HBF Textiles	11	•	•							
Cloud	SHBFCLD	HBF Textiles	11		•							
Abito	ABI	HBF Textiles	12	•	•							
Belgian Meadow	SHBFBLM	HBF Textiles	12	•	•							
Complex	964	HBF Textiles	12	•	•							
Crosstweed	991	HBF Textiles	12	•	•							
Cutout	SHBFCUT	HBF Textiles	12		•							
Dot Grid	975	HBF Textiles	12		•							
Dot Structure	SHBFDOT	HBF Textiles	12	•	•							
Glint	SHBFGLT	HBF Textiles	12	•	•					ped only		
Grateful Grid	1015	HBF Textiles	12	•	•							
Heartfelt	SHBFHTF	HBF Textiles	12	F	•					F		
Lava Rock	993	HBF Textiles	12	•	•							
Merci Boucle	SHBFMER	HBF Textiles	12		•							
Moving Blanket	SHBFMOV	HBF Textiles	12		•							
Sable Island	SHBFSAB	HBF Textiles	12	•	•							
Sir Stripe A Lot	1004	HBF Textiles	12	•	•							

Seating

- Available upholstery option
- RR: railroaded, F/FR: Fire compliant model

Pattern Name	Code	Supplier	Grade	Relate Uph Side	Seek	Soothe Back/ Single Fabric	Soothe Seat	Soothe High Back Back/ Single Fabric	Soothe High Back Seat	Stride and ASP7/ZSC Ped Toppers	Svelte	Svelte Channel Stitch
Sweater Weather	1030	HBF Textiles	12	•	•					•	•	
Twist	SHBFTWS	HBF Textiles	12	•	•					•	•	•
Upstart	1042	HBF Textiles	12	•	•	•				•	•	•
Cherished Knit	954	HBF Textiles	13	•	•	•				•	•	•
Enriched Boucle	1021	HBF Textiles	13	•	•					•	•	•
Foundation	SHBFFND	HBF Textiles	13									•
Moving Forward	1014	HBF Textiles	13	•	•					•	•	•
Night Earth	1013	HBF Textiles	13	•	•	•				•	•	•
Pepper Blend	995	HBF Textiles	13	•	•	•				•	•	•
Quill	1011	HBF Textiles	13	•	•	•				•	•	•
Scribble XL	983	HBF Textiles	13	•	•					•	•	•
Sister Solid	1003	HBF Textiles	13	•	•					•	•	•
Afghan	AFG	HBF Textiles	14	•	•					•	•	•
Smart	SHBFSMT	HBF Textiles	14		•					•	•	
Velvet Mix	977	HBF Textiles	14	•	•	•				•	•	
Hipster	SHBFHPT	HBF Textiles	15	F	•				F	•		
Landscape Blur	1024	HBF Textiles	15	•	•	•				•	•	•
Poodle	1009	HBF Textiles	16	•	•					•	•	•
Sweater	SHBFSWE	HBF Textiles	16								•	•
Woven Memory	1019	HBF Textiles	16	•	•					•	•	
Crafted Cloud	1018	HBF Textiles	19							•	•	
Knitwork	SHBFKNI	HBF Textiles	21	•	•							
Bunny	1012	HBF Textiles	23	•	•					•	•	•
Eccentric	966	HBF Textiles	23		•					•	•	•
Eccentric	SHBFEC	HBF Textiles	23		•							
Wild West	717	HBF Textiles	L2		•	•						
Aviator	SHBFAVI	HBF Textiles	L3									
Free Way	SHBFFRE	HBF Textiles	L3	•	•							
Modern Patina	716	HBF Textiles	L3		•	•						
Persuede	718	HBF Textiles	L3		•	•						
Vivace II	709	HBF Textiles	L3		•							
Upper Crust	708	HBF Textiles	L5		•							
Voyage	713	HBF Textiles	L5		•							

UPHOLSTERY

Seating

- Available upholstery option
- RR: railroaded, F/FR: Fire compliant model

UPHOLSTERY

Pattern Name	Code	Supplier	Grade			
				Versant	Vicinity Lounge	Vicinity Upholstered Seat
Parker	1054	HBF Textiles	3	•	•	•
Blink	1048	HBF Textiles	4	•	•	•
Look-See	1044	HBF Textiles	4	•	•	•
Walkabout	1046	HBF Textiles	4	•	•	•
Against the Grain	AGG	HBF Textiles	5			•
Caddy Corner	1016	HBF Textiles	5		•	•
Checkmate	1043	HBF Textiles	5	•	•	•
Pebbled	SHBFPEB	HBF Textiles	5		•	•
Picnic Plaid	1029	HBF Textiles	5		•	•
Upbeat	1036	HBF Textiles	5		•	•
Zippy	1045	HBF Textiles	5	•	•	•
Poppy	1047	HBF Textiles	6	•	•	•
Crew Cut	SHBFCRW	HBF Textiles	7	•	•	•
Happy Camper	1028	HBF Textiles	7		•	•
Honest	SHBFHON	HBF Textiles	7		•	•
Roundabout	1005	HBF Textiles	7		•	•
Beetle	SHBFBEE	HBF Textiles	8		•	•
Dashing	1008	HBF Textiles	8		•	•
Fourfold	SHBFFOU	HBF Textiles	8		•	•
Modern Tweed	SHBFMOD	HBF Textiles	8		•	•
Sherpa	1031	HBF Textiles	8		•	•
All Terrain	1027	HBF Textiles	9		•	•
Comfort Zone	905	HBF Textiles	9		•	•
Crafted Felt	1017	HBF Textiles	9		•	•
Curtain Wall	1023	HBF Textiles	9		•	•
High Rise	SHBFHIG	HBF Textiles	9		•	•
Madam Dottie	1001	HBF Textiles	9		•	•
Scribble XS	982	HBF Textiles	9		•	•
Uptown	1039	HBF Textiles	9		•	•
Wabi Sabi	SHBFWAB	HBF Textiles	9		•	•
Color Code	998	HBF Textiles	10		•	•
Digital Bloom 2.0	1050	HBF Textiles	10	•	•	•
Equation	SHBFEQU	HBF Textiles	10		•	•
Folded Lines	973	HBF Textiles	10		•	•
Remember	SHBFREM	HBF Textiles	10		•	•
Roy's Cords	1025	HBF Textiles	10		•	•
Soft Angles 2.0	1051	HBF Textiles	10	•	•	•
Upscale	1040	HBF Textiles	10		•	•
Air Mail	1006	HBF Textiles	11		•	•
Argyle Boucle	978	HBF Textiles	11		•	•
Brushed Canvas	SHBFBCV	HBF Textiles	11		•	•
Cloud	SHBFCLD	HBF Textiles	11		•	•
Abito	ABI	HBF Textiles	12		•	•
Belgian Meadow	SHBFBLM	HBF Textiles	12		•	•
Complex	964	HBF Textiles	12		•	•
Crosstweed	991	HBF Textiles	12		•	•
Cutout	SHBFCUT	HBF Textiles	12		•	•
Dot Grid	975	HBF Textiles	12		•	•
Dot Structure	SHBFDOT	HBF Textiles	12		•	•
Glint	SHBFGLT	HBF Textiles	12		•	•
Grateful Grid	1015	HBF Textiles	12		•	•
Heartfelt	SHBFHTF	HBF Textiles	12		•	•
Lava Rock	993	HBF Textiles	12		•	•
Merci Boucle	SHBFMER	HBF Textiles	12		•	•
Moving Blanket	SHBFMOV	HBF Textiles	12		•	•
Sable Island	SHBFSAB	HBF Textiles	12		•	•
Sir Stripe A Lot	1004	HBF Textiles	12		•	•

Seating

- Available upholstery option
- RR: railroaded, F/FR: Fire compliant model

Pattern Name	Code	Supplier	Grade	Versant	Vicinity Lounge	Vicinity Upholstered Seat
Sweater Weather	1030	HBF Textiles	12		•	•
Twist	SHBFTWS	HBF Textiles	12		•	•
Upstart	1042	HBF Textiles	12		•	•
Cherished Knit	954	HBF Textiles	13		•	•
Enriched Boucle	1021	HBF Textiles	13		•	•
Foundation	SHBFFND	HBF Textiles	13		•	•
Moving Forward	1014	HBF Textiles	13		•	•
Night Earth	1013	HBF Textiles	13		•	•
Pepper Blend	995	HBF Textiles	13		•	•
Quill	1011	HBF Textiles	13		•	•
Scribble XL	983	HBF Textiles	13		•	•
Sister Solid	1003	HBF Textiles	13		•	•
Afghan	AFG	HBF Textiles	14		•	•
Smart	SHBFSMT	HBF Textiles	14		•	•
Velvet Mix	977	HBF Textiles	14		•	•
Hipster	SHBFHPT	HBF Textiles	15		•	•
Landscape Blur	1024	HBF Textiles	15		•	•
Poodle	1009	HBF Textiles	16		•	•
Sweater	SHBFSWE	HBF Textiles	16		•	•
Woven Memory	1019	HBF Textiles	16		•	•
Crafted Cloud	1018	HBF Textiles	19		•	•
Knitwork	SHBFKNI	HBF Textiles	21		•	•
Bunny	1012	HBF Textiles	23		•	•
Eccentric	966	HBF Textiles	23		•	•
Eccentric	SHBFEC	HBF Textiles	23		•	•
Wild West	717	HBF Textiles	L2		•	•
Aviator	SHBFAVI	HBF Textiles	L3		•	•
Free Way	SHBFFRE	HBF Textiles	L3		•	•
Modern Patina	716	HBF Textiles	L3		•	•
Persuede	718	HBF Textiles	L3		•	•
Vivace II	709	HBF Textiles	L3		•	•
Upper Crust	708	HBF Textiles	L5		•	•
Voyage	713	HBF Textiles	L5		•	•

UPHOLSTERY

Paint Name	Allsteel Code	Grade	Clubhouse	Clubhouse Tile	Clubhouse Table Extension	Vicinity Seating	Acuity Work / Conference	Acuity Multi-Purpose Side	Relate Work/Conference, Aluminum Work/Conference, Work Stool Mesh Back	Relate Work/Conference, Aluminum Work/Conference Upholstered Back	Aluminum Relate Work / Conference Stool Mesh Back	Relate Multi-Purpose Side, 4-Legged
Black	P71	1				•	•					
Carbon	P4Q	1										
Charblack	CBK	1						•	•			•
Charblack Metallic*	P80	1										
Designer White	PJW	1		•	•							
Flint	P02	1		•	•							
Salt	P8C	1										
Black Mica Texture	P6P	1										
Textured Designer White	PK7	1	•	•								
Textured Flint	P7A	1	•	•								
Titanium	P8T / T	1				•	•	•				•
Graphite Metallic Texture	P85	2				•	•					
Night Bronze	P8B	2				•						
Pyrite	PJE	2				•						
Silver	PR6	2		•	•	•	•					•
Silver Generic	SVR	2										
Silver Texture	PR8	2	•	•								
Solar Black	P8X	2				•	•					•
Bullseye	PJF	3				•						
Polished Aluminum	PAL / P	4				•				•		
Polished Chrome	POL	4				•						

FINISHES

	Relate Multi-Purpose Side Stool Upholstered and Wood Back	Svelte	Lyric Work / Conference & Stool Base	Lyric MP 4 Leg, Lyric MP Stool	Lyric Side Chair & Lyric MP Stacker, Frame Finish	Mineo Task Base	Clarity Task, Clarity Guest, Clarity Lounge	Clarity Value Task	Clarity Value Task	Inspire	Nimble	Evo Task Fixed Arms, Evo Conference Fixed Arms, Evo Stool Fixed Arms	Evo Task, Evo Conference, Evo Side Chair	Seek
	•		•	•	•	•	•	•		•		•	•	•
•									•					
			•				•							
			•									•	•	
					•							•	•	
			•	•		•	•		•	•		•	•	•
•			•	•			•		•	•		•	•	•
•			•	•		•			•	•		•	•	•
			•											
	•	•			•	•					•	•		

FINISHES

Paint Name	Allsteel Code	Grade	Parallel Frames & Table Bases	Parallel Arm Sleeve	Linger Base	Rise Tray	Vicinity Lounge	Recharge Tables
Black	P27	1				•		
Black	P71	1		•		•	•	
Brownstone	P7D	1		•		•		
Bungalow	P7C	1				•		
Carbon	P4Q	1	•	•				
Charblack	CBK	1						
Cinder	P7Q	1		•		•		
Designer White	PJW	1	•	•		•	•	
Flint	P02	1		•		•	•	
Fossil	P28	1		•		•		
Loft	P7B	1		•		•		
Muslin	P4J	1		•		•		
Parchment	P93	1		•		•		
Pebble	P8R	1		•		•		
Pewter	P8D	1		•		•		
Salt	P8C	1		•		•		
Textured Brownstone	P7J	1						
Textured Designer White	PK7	1						•
Textured Flint	P7A	1						•
Textured Loft	P7L	1						
Textured Muslin	P7M	1						
Textured Pebble	P8Y	1						
Textured Salt	P8Z	1						
Textured Titanium	P8V	1						
Titanium	P8T / T	1		•		•		
Champagne Metallic	PR5	2		•		•		
Designer White High Gloss 65	P8W	2				•		
Gunmetal Metallic	PR3	2		•		•		
Night Bronze	P8B	2		•		•		
Pyrite	PJE	2	•	•		•	•	
Silver	PR6	2	•	•	•	•	•	
Silver Texture	PR8	2						•
Solar Black	P8X	2		•		•		
Atom	P8S	3		•		•		
Blossom	P8K	3		•		•		
Bullseye	PJF	3		•		•	•	
Ember	P8P	3		•		•		
Ion	P8N	3		•		•		
Iris	P8J	3		•		•		
Krypton	P8F	3		•		•		
Regatta	P8M	3		•		•		
Succulent	P8A	3		•		•		
Polished Aluminum	PAL / P	4			•			
Polished Chrome	POL	4	•				•	

Paint Name	Allsteel Code	Grade	Harvest Classic Tables	Belong Glass Top and Bases	Recharge Tables	Aware Credenza Inserts	Aware Credenzas	Aware Lectern
Black	P27	1	•	•	•			
Black	P71	1	•	•	•			
Brownstone	P7D	1	•	•	•			
Bungalow	P7C	1	•	•	•			
Carbon	P4Q	1						
Charblack	CBK	1						
Charblack Metallic*	P80	1						
Cinder	P7Q	1	•	•	•			
Designer White	PJW	1	•	•	•	•	•	•
Flint	P02	1	•	•	•	•	•	•
Fog	FOG	1						
Fossil	P28	1	•	•	•			
Greige		1						
Light Grey	P06	1						
Loft	P7B	1	•	•	•			
Muslin	P4J	1	•	•	•			
Nickel	P8L	1						
Parchment	P93	1			•			
Pebble	P8R	1	•	•	•			
Pewter	P8D	1	•	•	•			
Platinum Metallic Texture	P6H	1						
Putty	PJS	1						
Salt	P8C	1	•	•	•			
Shadow	P4K	1						
Textured Brownstone	P7J	1						
Textured Designer White	PK7	1						
Textured Flint	P7A	1						
Textured Loft	P7L	1						
Textured Muslin	P7M	1						
Textured Pebble	P8Y	1						
Textured Salt	P8Z	1						
Textured Titanium	P8V	1						
Titanium	P8T / T	1	•	•	•			
White	PD8	1						
Anodized Silver	PR0	2						
Bronze		2						
Champagne Metallic	PR5	2	•	•	•			
Designer White High Gloss 65	P8W	2	•	•	•			
Graphite Metallic Texture	P85	2						
Gunmetal Metallic	PR3	2	•	•	•			
Matte Gold	P8G	2						
Night Bronze	P8B	2	•	•	•			
Platinum Metallic	PR2	2	•	•	•			
Pyrite	PJE	2	•	•	•			
Silver	PR6	2	•	•	•	•	•	•
Silver Generic	SVR	2						
Silver Texture	PR8	2						
Solar Black	P8X	2	•	•	•			
Atom	P8S	3	•	•	•	•		
Blossom	P8K	3	•	•	•			

Paint Name	Allsteel Code	Grade	Harvest Classic Tables	Belong Glass Top and Bases	Aware	Aware Credenza Inserts	Aware Credenzas	Aware Lectern
Bullseye	PJF	3	•	•	•			
Ember	P8P	3	•	•	•			
Ion	P8N	3	•	•	•			
Iris	P8J	3	•	•	•			
Krypton	P8F	3	•	•	•	•		
Regatta	P8M	3	•	•	•			
Succulent	P8A	3	•	•	•			
Anodized Aluminum	AAL	1						
Black Anodized Aluminum	BKAL	1						
Satin Anodized Aluminum	SAL	1						
Brushed Stainless / Brushed Chrome Steel		4						
Polished Aluminum	PAL / P	4						
Polished Chrome	POL	4						
Markerboard White	MKP	6						

FINISHES

Aware Mobile Boards	Aware Polished Only	Merge Adaptative Table Base	Merge Polished Adaptative Table Base	Structure Tables Painted Foot	Structure Tables Pedestal Base	Structure Table Wall Mount Bracket & Table Media Bracket	Structure Tables Polished Foot Option X Base, T-Leg Base, Adaptive Table & Adjustable Table
				•			•
				•			•
				•			•
				•			•
				•			•
				•			•
				•			•
	•		•				•

FINISHES

Pattern Name	Code	Grade	Harvest Classic Tables & Bases	Harvest Rustic Surfaces	Structure Table Tops	Structure Table Tops Solid Laminate Only (Panel, Cube, Cylinder)	Tables (Aware, Belong, Merge, Vicinity)	Townhall	Parallel Tables	Park by Norm Architects	Park Planter Cap	Recharge Tables	Rise	Two Thirds
Ash	LT3B	1												
Handspun Dove	LAHD	1	•											
Handspun Pearl	LAHP	1	•											
Handspun Chestnut	LAHC	1	•											
Handspun Slate	LAHS	1	•											
Silver Mesh	LT8D	1	•											
Black	P	1	•	•	•	•	•	•	•	•	•	•	•	•
Brownstone	LM13	1	•	•	•	•	•	•	•	•	•	•	•	•
Bungalow	LM12	1	•	•	•	•	•	•	•	•	•	•	•	•
Designer White 15051	LDW1	1	•	•	•	•	•	•	•	•	•	•	•	•
Flint	LM16	1	•	•	•	•	•	•	•	•	•	•	•	•
Fossil Shale	LEH1	1	•	•	•	•	•	•	•	•	•	•	•	•
Loft	LM11	1	•	•	•	•	•	•	•	•	•	•	•	•
Muslin	LM15	1	•	•	•	•	•	•	•	•	•	•	•	•
Titanium	LT11	1	•	•	•	•	•	•	•	•	•	•	•	•
Belair	LWBA	1	•	•	•	•	•	•	•	•	•	•	•	•
Bourbon Cherry	H	1	•	•	•	•	•	•	•	•	•	•	•	•
Field Elm	LWFE	1	•	•	•	•	•	•	•	•	•	•	•	•
Florence Walnut	LFW1	1	•	•	•	•	•	•	•	•	•	•	•	•
Kingswood Walnut	LK11	1	•	•	•	•	•	•	•	•	•	•	•	•
Natural Maple	LWD	1	•	•	•	•	•	•	•	•	•	•	•	•
NeoWalnut	LNU1	1	•	•	•	•	•	•	•	•	•	•	•	•
Pinnacle	PINC	1	•	•	•	•	•	•	•	•	•	•	•	•
Shaker Cherry	LW7C	1	•	•	•	•	•	•	•	•	•	•	•	•
Beigewood	LWBE	2	•	•	•	•	•	•	•	•	•	•	•	•
Fawn Cypress	LFC1	2	•	•	•	•	•	•	•	•	•	•	•	•
Lowell Ash	LLA1	2	•	•	•	•	•	•	•	•	•	•	•	•
Mangalore Mango	LMM1	2	•	•	•	•	•	•	•	•	•	•	•	•
Natural Recon	LNR1	2	•	•	•	•	•	•	•	•	•	•	•	•
Phantom Charcoal	LPC1	2	•	•	•	•	•	•	•	•	•	•	•	•
Phantom Ecrú	LPE1	2	•	•	•	•	•	•	•	•	•	•	•	•
Portico Teak	LPT1	2	•	•	•	•	•	•	•	•	•	•	•	•
Skyline Walnut	LSW1	2	•	•	•	•	•	•	•	•	•	•	•	•
Veranda Teak	LVT1	2	•	•	•	•	•	•	•	•	•	•	•	•
Natural Walnut	LWNW	3	•	•	•	•	•	•	•	•	•	•	•	•
Open Line Laminate Program	N/A	Variable		•	•		•	•	•		•			

Pattern Name	Code	Grade	Inspire Tablet	Clubhouse
Ash	LT3B	1		•
Handspun Chestnut	LAHC	1	•	•
Handspun Dove	LAHD	1	•	•
Handspun Pearl	LAHP	1	•	•
Handspun Slate	LAHS	1	•	•
Silver Mesh	LT8D	1	•	•
Black	P	1		•
Designer White 15051	LDW1	1		•
Flint	LM16	1		•
Fossil Shale	LEH1	1		•
Loft	LM11	1		•
Muslin	LM15	1		•
Titanium	LT11	1		•
Belair	LWBA	1		•
Bourbon Cherry	H	1		•
Field Elm	LWFE	1		•
Florence Walnut	LFW1	1		•
Kingswood Walnut	LK11	1		•
Natural Maple	LWD	1	•	•
NeoWalnut	LNU1	1		•
Pinnacle	PINC	1		•
Shaker Cherry	LW7C	1		•
Beigewood	LWBE	2		•
Fawn Cypress	LFC1	2		•
Lowell Ash	LLA1	2		•
Mangalore Mango	LMM1	2		•
Natural Recon	LNR1	2		•
Phantom Charcoal	LPC1	2		•
Phantom Ecrú	LPE1	2		•
Portico Teak	LPT1	2		•
Skyline Walnut	LSW1	2		•
Veranda Teak	LVT1	2		•
Natural Walnut	LWNW	3		•
Open Line Laminate Program	N/A	Variable		

FINISHES

Veneer Type	Stain Name	Code	Grade	Parallel Tables	Two Thirds
FSC Stratawood Cherry	Cinnamon Cherry	FSCSC260	2	•	
FSC Stratawood Cherry	Lowell Ash	FSCSC394	2	•	
FSC Stratawood Cherry	Clear Cherry	FSCSC700	2	•	
FSC Stratawood Cherry	Light Cherry	FSCSC701	2	•	
FSC Stratawood Cherry	Burnished Cherry	FSCSC777	2	•	
FSC Stratawood Cherry	Shaker Cherry	FSCSC774	2	•	
FSC Stratawood Maple	Field Elm	FSCSE599	2	•	
FSC Stratawood Maple	Clear Maple	FSCSE800	2	•	
FSC Stratawood Maple	Harvest Maple	FSCSE856	2	•	
FSC Stratawood Maple	Beigewood	FSCSE878	2	•	
FSC Stratawood Maple	Phantom Ecu	FSCSE912	2	•	
FSC Stratawood Maple	Belair	FSCSE934	2	•	
FSC Stratawood Oak	Clear Oak	FSCSF300	2	•	
FSC Stratawood Oak	Dark Rift Cut Oak	FSCSF331	2	•	
FSC Stratawood Walnut	Florence Walnut	FSCST579	2	•	
FSC Stratawood Walnut	Light Walnut	FSCST601	2	•	
FSC Stratawood Walnut	Skyline Walnut	FSCST625	2	•	
FSC Stratawood Walnut	Pinnacle Walnut	FSCST679	2	•	
FSC Stratawood Walnut	Sumatra Walnut	FSCST693	2	•	
FSC Natural Cherry	Cinnamon Cherry	FSCNC260	2	•	
FSC Natural Cherry	Light Cherry	FSCNC701	2	•	
FSC Natural Cherry	Burnished Cherry	FSCNC777	2	•	
FSC Natural Cherry	Lowell Ash	FSCNC394	2	•	
FSC Natural Cherry	Medium Red Cherry	FSCNC512	2	•	
FSC Natural Cherry	Shaker Cherry	FSCNC774	2	•	
FSC Natural Maple	Clear Maple	FSCNE800	2	•	
FSC Natural Maple	Harvest Maple	FSCNE856	2	•	
FSC Natural Walnut	Ebony Walnut	FSCNT509	2	•	
FSC Natural Walnut	Florence Walnut	FSCNT579	2	•	
FSC Natural Walnut	Light Walnut	FSCNT601	2	•	
FSC Natural Walnut	Skyline Walnut	FSCNT625	2	•	
FSC Natural Walnut	Nutmeg Walnut	FSCNT629	2	•	
FSC Natural Walnut	Pinnacle Walnut	FSCNT679	2	•	
FSC Natural Walnut	Sumatra Walnut	FSCNT693	2	•	
FSC Natural Rift Cut Oak	Fawn Cypress	FSCRF108	3	•	
FSC Natural Rift Cut Oak	Light Rift Cut Oak	FSCRF301	3	•	
FSC Natural Rift Cut Oak	Dark Rift Cut Oak	FSCRF331	3	•	
FSC Natural Rift Cut Oak	Phantom Ecu	FSCRF912	3	•	
Natural Cherry	Cinnamon Cherry	NC260	2	•	•
Natural Cherry	Lowell Ash	NC394	2	•	
Natural Cherry	Medium Red Cherry	NC512	2	•	•
Natural Cherry	Light Cherry	NC701	2	•	•
Natural Cherry	Shaker Cherry	NC774	2	•	
Natural Cherry	Burnished Cherry	NC777	2	•	•
Natural Maple	Clear Maple	NE800	2	•	•
Natural Maple	Harvest Maple	NE856	2	•	•
Natural Rift Cut Oak	Fawn Cypress	RF108	3	•	•
Natural Rift Cut Oak	Light Rift Cut Oak	RF301	3	•	•
Natural Rift Cut Oak	Dark Rift Cut Oak	RF331	3	•	•
Natural Rift Cut Oak	Phantom Ecu	RF912	3	•	•
Natural Walnut	Ebony Walnut	NT509	2	•	•
Natural Walnut	Florence Walnut	NT579	2	•	•
Natural Walnut	Light Walnut	NT601	3	•	•
Natural Walnut	Skyline Walnut	NT625	2	•	•
Natural Walnut	Nutmeg Walnut	NT629	2	•	•
Natural Walnut	Pinnacle Walnut	NT679	2	•	•
Natural Walnut	Sumatra Walnut	NT693	2	•	•

Veneer Type	Stain Name	Code	Grade	Parallel Tables	Two Thirds
Stratawood Cherry	Cinnamon Cherry	SC260	2	•	•
Stratawood Cherry	Lowell Ash	SC394	2	•	•
Stratawood Cherry	Clear Cherry	SC700	2	•	•
Stratawood Cherry	Light Cherry	SC701	2	•	•
Stratawood Cherry	Shaker Cherry	SC774	2	•	•
Stratawood Cherry	Burnished Cherry	SC777	2	•	•
Stratawood Maple	Field Elm	SE599	2	•	•
Stratawood Maple	Clear Maple	SE800	2	•	•
Stratawood Maple	Harvest Maple	SE856	2	•	•
Stratawood Maple	Beigewood	SE878	2	•	•
Stratawood Maple	Phantom Ecu	SE912	2	•	•
Stratawood Maple	Belair	SE934	2	•	•
Stratawood Silver Oak	Clear	SB100	2	•	•
Stratawood Silver Oak	Portico Teak	SB150	2	•	•
Stratawood Oak	Clear Oak	SF300	2	•	•
Stratawood Oak	Dark Rift Cut Oak	SF331	2	•	•
Stratawood Walnut	Florence Walnut	ST579	2	•	•
Stratawood Walnut	Light Walnut	ST601	2	•	•
Stratawood Walnut	Skyline Walnut	ST625	2	•	•
Stratawood Walnut	Pinnacle Walnut	ST679	2	•	•
Stratawood Walnut	Sumatra Walnut	ST693	2	•	•

FINISHES

Veneer Type	Stain Name	Code	Grade	Relate MP Side	Reflect	Vicinity Lounge
Natural Cherry	Light Cherry	NC701	2	•		
Natural Cherry	Burnished Cherry	NC777	2	•		
Natural Maple	Clear Maple	NE800	2	•		
Stratawood Cherry	Light Cherry	SC701	2		•	
Stratawood Cherry	Burnished Cherry	SC777	2		•	
Stratawood Maple	Field Elm	SE599	2		•	
Stratawood Maple	Clear Maple	SE800	2		•	
Stratawood Maple	Harvest Maple	SE856	2		•	
Stratawood Maple	Phantom Ecu	SE912	2		•	
Stratawood Maple	Belair	SE934	2		•	
Stratawood Oak	Clear Oak	SF300	2		•	
Stratawood Oak	Dark Rift Cut Oak	SF331	2		•	
Vicinity Veneer	Natural Oak	NF302				•
Vicinity Veneer	Warm Brown Oak	NF394				•
Vicinity Veneer	Black Wash Beech	RB997				•
Vicinity Veneer	Grey Wash Oak	NF314				•
Vicinity Veneer	Natural Walnut	QT500				•
Vicinity Veneer	Natural Beech	RB900				•
Vicinity Veneer	White Wash Beech	RB912				•

Veneer Type	Stain Name	Code	Grade	Aware Tables	Belong Tables	Harvest Classic Tables & Bases	Harvest Metal Veneer Surfaces (Tops)	Harvest Rustic Tables
FSC Stratawood Cherry	Cinnamon Cherry	FSCSC260	2	•	•	•	•	
FSC Stratawood Cherry	Lowell Ash	FSCSC394	2	•	•	•	•	
FSC Stratawood Cherry	Clear Cherry	FSCSC700	2	•	•	•	•	
FSC Stratawood Cherry	Light Cherry	FSCSC702	2	•	•	•	•	
FSC Stratawood Cherry	Shaker Cherry	FSCSC774	2	•	•	•	•	
FSC Stratawood Cherry	Burnished Cherry	FSCSC777	2	•	•	•	•	
FSC Stratawood Maple	Field Elm	FSCSE599	2	•	•	•	•	
FSC Stratawood Maple	Clear Maple	FSCSE800	2	•	•	•	•	
FSC Stratawood Maple	Harvest Maple	FSCSE856	2	•	•	•	•	
FSC Stratawood Maple	Beigewood	FSCSE878	2	•	•	•	•	
FSC Stratawood Maple	Phantom Ecu	FSCSE922	2	•	•	•	•	
FSC Stratawood Maple	Belair	FSCSE934	2	•	•	•	•	
FSC Stratawood Oak	Clear Oak	FSCSF300	2	•	•	•	•	
FSC Stratawood Oak	Dark Rift Cut Oak	FSCSF332	2	•	•	•	•	
FSC Stratawood Walnut	Florence Walnut	FSCST579	2	•	•	•	•	
FSC Stratawood Walnut	Light Walnut	FSCST602	2	•	•	•	•	
FSC Stratawood Walnut	Skyline Walnut	FSCST625	2	•	•	•	•	
FSC Stratawood Walnut	Pinnacle Walnut	FSCST679	2	•	•	•	•	
FSC Stratawood Walnut	Sumatra Walnut	FSCST693	2	•	•	•	•	
FSC Natural Cherry	Cinnamon Cherry	FSCNC260	2	•	•	•	•	
FSC Natural Cherry	Lowell Ash	FSCNC394	2	•	•	•	•	
FSC Natural Cherry	Medium Red Cherry	FSCNC522	2	•	•	•	•	
FSC Natural Cherry	Light Cherry	FSCNC702	2	•	•	•	•	
FSC Natural Cherry	Shaker Cherry	FSCNC774	2	•	•	•	•	
FSC Natural Cherry	Burnished Cherry	FSCNC777	2	•	•	•	•	
FSC Natural Maple	Clear Maple	FSCNE800	2	•	•	•	•	
FSC Natural Maple	Harvest Maple	FSCNE856	2	•	•	•	•	
FSC Natural Walnut	Ebony Walnut	FSCNT509	2	•	•	•	•	
FSC Natural Walnut	Florence Walnut	FSCNT579	2	•	•	•	•	
FSC Natural Walnut	Light Walnut	FSCNT602	2	•	•	•	•	
FSC Natural Walnut	Skyline Walnut	FSCNT625	2	•	•	•	•	
FSC Natural Walnut	Nutmeg Walnut	FSCNT629	2	•	•	•	•	
FSC Natural Walnut	Pinnacle Walnut	FSCNT679	2	•	•	•	•	
FSC Natural Walnut	Sumatra Walnut	FSCNT693	2	•	•	•	•	
FSC Natural Rift Cut Oak	Fawn Cypress	FSCRF208	3	•	•	•	•	
FSC Natural Rift Cut Oak	Light Rift Cut Oak	FSCRF302	3	•	•	•	•	
FSC Natural Rift Cut Oak	Dark Rift Cut Oak	FSCRF332	3	•	•	•	•	
FSC Natural Rift Cut Oak	Phantom Ecu	FSCRF922	3	•	•	•	•	
Natural Cherry	Cinnamon Cherry	NC260	2	•	•	•	•	
Natural Cherry	Lowell Ash	NC394	2	•	•	•	•	
Natural Cherry	Medium Red Cherry	NC522	2	•	•	•	•	
Natural Cherry	Light Cherry	NC702	2	•	•	•	•	
Natural Cherry	Shaker Cherry	NC774	2	•	•	•	•	
Natural Cherry	Burnished Cherry	NC777	2	•	•	•	•	
Natural Maple	Clear Maple	NE800	2	•	•	•	•	
Natural Maple	Harvest Maple	NE856	2	•	•	•	•	
Natural Rift Cut Oak	Fawn Cypress	RF208	3	•	•	•	•	
Natural Rift Cut Oak	Light Rift Cut Oak	RF302	3	•	•	•	•	
Natural Rift Cut Oak	Dark Rift Cut Oak	RF332	3	•	•	•	•	
Natural Rift Cut Oak	Phantom Ecu	RF922	3	•	•	•	•	
Natural Walnut	Ebony Walnut	NT509	2	•	•	•	•	
Natural Walnut	Florence Walnut	NT579	2	•	•	•	•	
Natural Walnut	Light Walnut	NT602	2	•	•	•	•	
Natural Walnut	Skyline Walnut	NT625	2	•	•	•	•	
Natural Walnut	Nutmeg Walnut	NT629	2	•	•	•	•	
Natural Walnut	Pinnacle Walnut	NT679	2	•	•	•	•	
Natural Walnut	Sumatra Walnut	NT693	2	•	•	•	•	

Veneer Type	Stain Name	Code	Grade	Aware Tables	Belong Tables	Harvest Classic Tables & Bases	Harvest Metal Veneer Surfaces (Tops)	Harvest Rustic Tables
Solid Plank Maple	Medium Grey	LL814						•
Solid Plank Maple	Light Neutral	LL815						•
Solid Plank Maple	Dark Brown	LL897						•
Stratawood Cherry	Cinnamon Cherry	SC260	2	•	•	•	•	
Stratawood Cherry	Lowell Ash	SC394	2	•	•	•	•	
Stratawood Cherry	Clear Cherry	SC700	2	•	•	•	•	
Stratawood Cherry	Light Cherry	SC701	2	•	•	•	•	
Stratawood Cherry	Shaker Cherry	SC774	2	•	•	•	•	
Stratawood Cherry	Burnished Cherry	SC777	2	•	•	•	•	
Stratawood Maple	Field Elm	SE599	2	•	•	•	•	
Stratawood Maple	Clear Maple	SE800	2	•	•	•	•	
Stratawood Maple	Harvest Maple	SE856	2	•	•	•	•	
Stratawood Maple	Beigewood	SE878	2	•	•	•	•	
Stratawood Maple	Phantom Ecu	SE912	2	•	•	•	•	
Stratawood Maple	Belair	SE934	2	•	•	•	•	
Stratawood Silver Oak	Clear	SB100	2	•	•	•	•	
Stratawood Silver Oak	Portico Teak	SB150	2	•	•	•	•	
Stratawood Oak	Clear Oak	SF300	2	•	•	•	•	
Stratawood Oak	Dark Rift Cut Oak	SF331	2	•	•	•	•	
Stratawood Walnut	Florence Walnut	ST579	2	•	•	•	•	
Stratawood Walnut	Light Walnut	ST601	2	•	•	•	•	
Stratawood Walnut	Skyline Walnut	ST625	2	•	•	•	•	
Stratawood Walnut	Pinnacle Walnut	ST679	2	•	•	•	•	
Stratawood Walnut	Sumatra Walnut	ST693	2	•	•	•	•	

Seating (Arm and armless versions available for most models.)

Acuity® pages 48-55



High-Back Work Chair



Side Chair

Clarity® pages 56-59



Work Chair

Evo™ pages 60-65



High-Back Work Chair



Mid-Back Conference



High-Back Work Stool

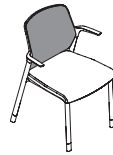

Side Chair

Inspire® pages 67-85



4-Leg Multi-Purpose



Sled Base Multi-Purpose



4-Leg Tablet Arm



Multi-Purpose Work Chair



Multi-Purpose Work Stool



4-Leg Stool

Lyric™ pages 86-101



High-Back Work Chair



High-Back Work Stool



Large & Tall Work Chair



Side Chair



4-Leg Multi-Purpose



Multi-Purpose Work Chair



Wire Stool



Wire Stacker Multi-Purpose

Mimeo™ pages 102-105



Work Chair



Work Stool

Nimble® pages 106-107
(De-emphasized)



High Density Stacking Chair

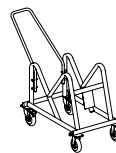

Chair Cart

O6™ pages 108-111



High-Back Work Chair



High-Back Work Stool

Seating (Arm and armless versions available for most models.)

Pli™ pages 112-115

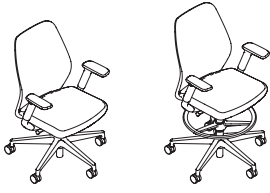

Work Chair

Work Stool

Quip™ pages 116-117



Work Chair

Relate® pages 118-133



High-Back
Work Chair



High-Back
Work Stool



Side Chair



4-Leg Stool

Seek® pages 134-137



Multi-Purpose
Stacking and
Nesting Chair

Svelte pages 139-141



High Back Chair



Mid Back Chair

Vicinity™ pages 142-145

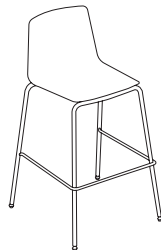

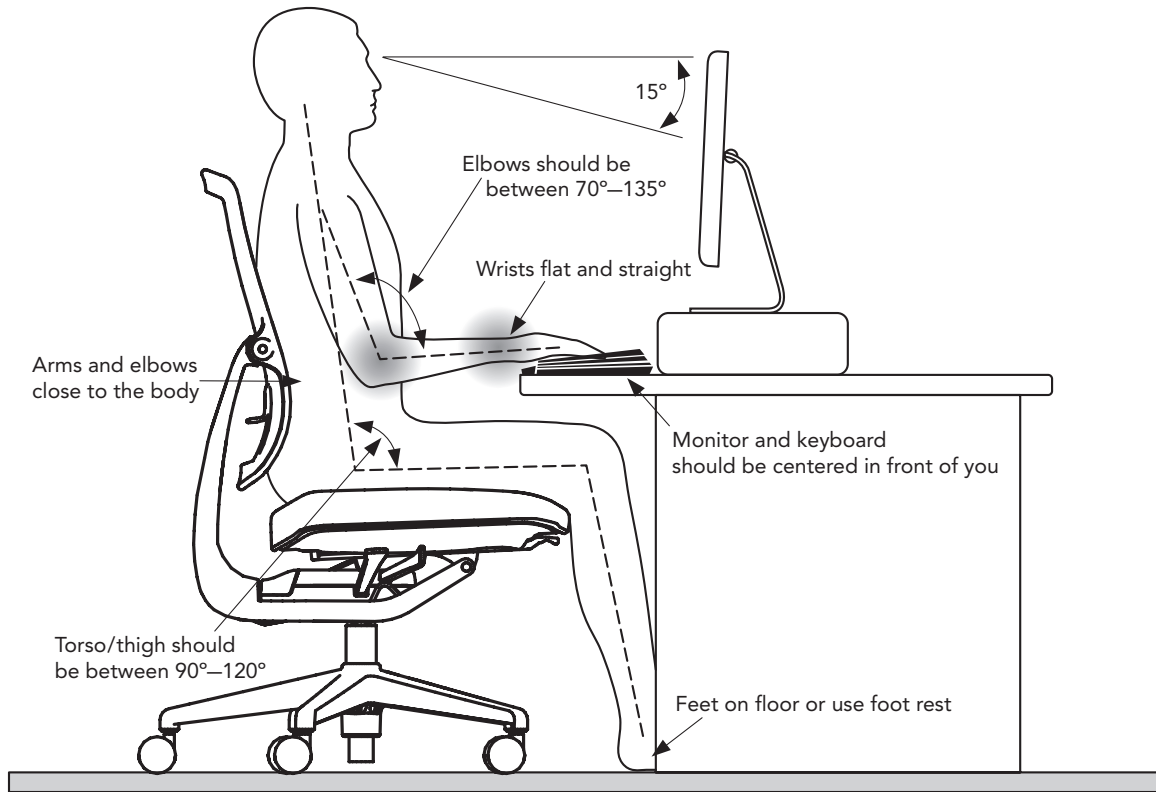

Measurements based on BIFMA G1-2013 guidelines. Many of the measurements are taken from the compressed seat (dotted horizontal line) and the tangent lumbar apex (dotted vertical line).

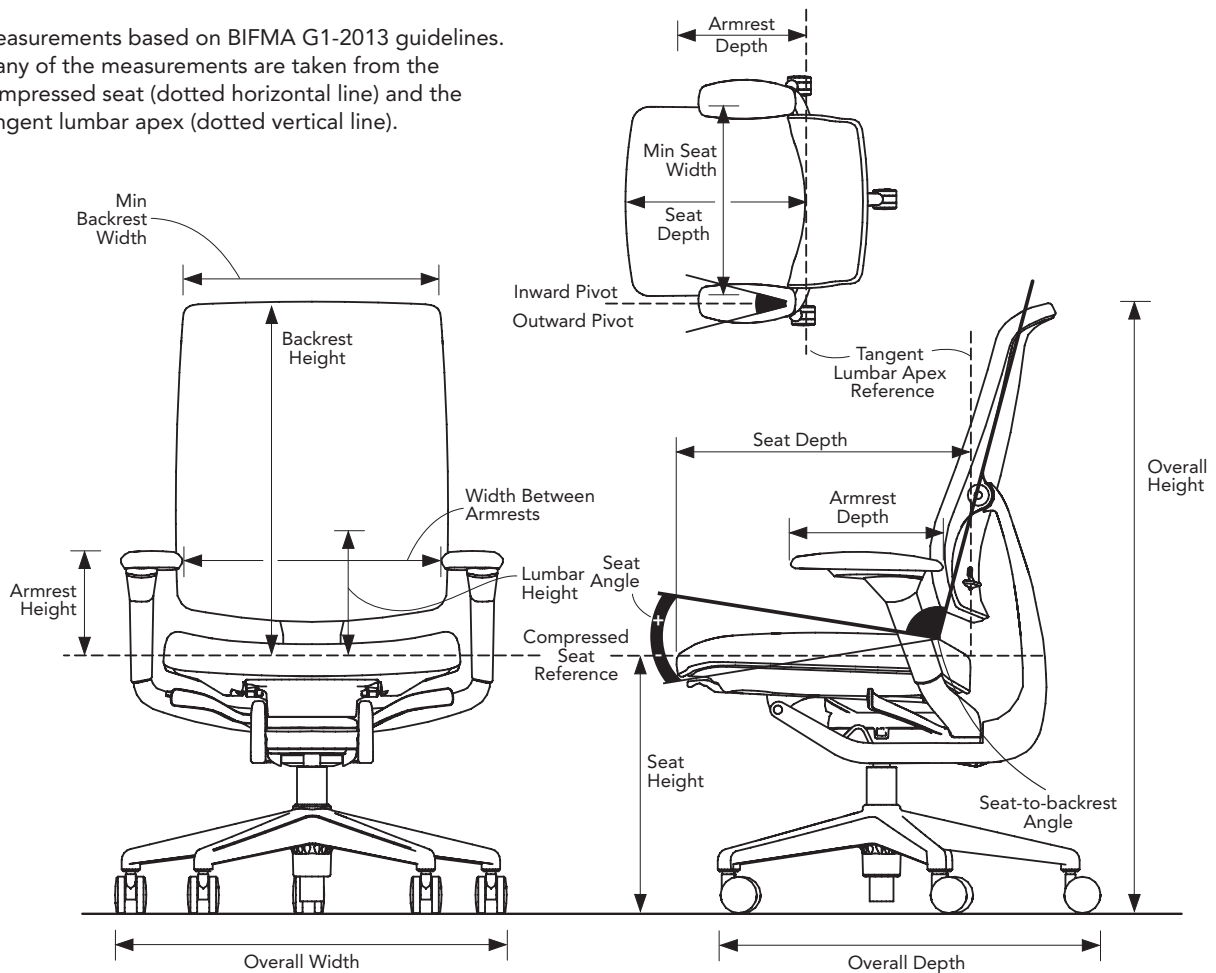

ANSI — (American National Standards Institute) ANSI is a private, non-profit organization (501(c)3) that administers and coordinates the U.S. voluntary standardization and conformity assessment system.

Asynchronous — High-performance seating control system with three levers to modify adjustments on the chair for a more customized fit:

- Angle of back relative to seat
- Tilt (free float or infinite locking)
- Forward tilt of seat

ASTM Standards — (American Society for Testing and Materials) is an international standards group that develops and publishes technical standards for many products, materials, and services.

BIFMA — (Business and Institutional Furniture Manufacturer's Association) Produces voluntary standards for manufacturers of office furnishings. These standards are intended to provide a common basis for the evaluation of safety, durability, dimensions, ergonomics, and the structural adequacy of the specified furniture.

CAL TB117-2013 — Method used to test open flame resistance of components of upholstered furniture. This test is done with a lighted cigarette placed in crevices of mock-up components.

CFC — (Chlorofluorocarbons) CFCs are broken down by strong ultraviolet light in the stratosphere and release chlorine atoms that then deplete the ozone layer. CFCs are commonly used as refrigerants, solvents, and foam blowing agents.

COL — (Customer's Own Leather)

COM — (Customer's Own Material) See pages 6-8.

Ergonomic — The coordination of the design of a product with the capacities and requirements of the user.

HFES — (Human Factors and Ergonomics Society) A membership-based organization whose mission is to promote the discovery and exchange of knowledge concerning the characteristics of human beings that are applicable to the design of systems and devices of all kinds.

Knee Tilt — A seating control that pivots about a point underneath the knee (towards the front of the seat) to reduce pressure on the back of the legs when reclining.

Memory Foam — Viscoelastic foam developed by NASA that retains the shape impressed upon it to reduce pressure points and distribute the load on the seat more evenly.

NFPA261 — Method of test for determining resistance of mock-up upholstered furniture material assemblies to ignition by a smoldering cigarette. This test is done with a lighted cigarette placed in crevices of mock-up components.

NFPA266 — Method of test for fire characteristics of upholstered furniture exposed to flaming ignition source. This is a full-scale test of mock up. Equivalent to CAL133

Pneumatic — Operated by compressed air in a tool or machine

Powder Coat — Dry paint electrostatically charged for better adhesion to parts and baked on for a durable finish.

Recyclable — Able to be reclaimed and re-used into another value-added product.

Recycled — Made from post-industrial or post-consumer waste products.

Synchro-Tilt — A seating control where the chair back reclines at a prescribed ratio in relation to seat angle. Allows user to recline while keeping seat cushion relatively level to the floor.

Urethane — Synthetic plastic; any of a group of thermoplastic polymers that are used in resins, coatings, insulation, adhesives, foams, and fibers.

Weight-Activated — A seating control that has the recline tension engineered into the chair so that the chair recline tension will automatically vary depending on the weight of the user reclining the chair.

Wyzenbeck Testing — Method of testing the abrasion resistance of a fabric utilizing a cotton duck or wire mesh that is rubbed, back and forth (a double rub), over the fabric.

Acuity is a chair that enhances any environment, any body. Designed in collaboration with Bruce Fifield of Milan-based Design Continuum Italia, Acuity is designed with Italian sensibility and Allsteel ingenuity. Its design and ergonomics work seamlessly while the controls are intuitive. Acuity is elegant and pleasing to the eye, as anything inessential has been stripped away, leaving behind only a purity of form.

Acuity is level®2 certified and has achieved SCS Indoor Advantage™ Gold Certification. Acuity is designed and manufactured to have minimal impact on both the physical and social environment, made with no PVC components and has a recycled content of 28%-37%, depending on chair base selected.

KEY FEATURES

AcuFit®

Acuity provides ideal ergonomics, instantly. We used the latest anthropometric databases, high-tech modeling, and intense observation to understand just what a body needs. You'll feel it the minute you sit – snug support and contoured cushioning that conforms to your body and stays with you throughout the day. No matter what size you are or how you work, Acuity adapts, automatically.

Weight-activated mechanism

A ground-breaking, weight-activated mechanism built into the chair's structure does two things critical to effective ergonomics: automatically adjusts recline tension in response to the user's weight; and, keeps the seat and back moving smoothly together during recline, thereby maintaining perfect balance, body angle, and focus.

Hybrid seat cushion

A unique combination of materials provides properties critical to comfort. A molded foam base with additional memory foam offers softness when you first sit along with greater support over time. This translates into instant comfort, the elimination of pressure points, and a healthy sitting experience over every hour of the day.

Conforming mesh back

Form creates function with a back designed to provide ideal ergonomics for bodies of every shape and size. The mesh carrier mirrors the shape of the human spine, offering snug support to the shoulders, lumbar area, and everywhere in between, simultaneously and continuously. In addition, the structure and materials of the yoke have inherent dynamic properties that promote healthy posture by allowing just the right amount of flex and body movement.

Intuitive Controls

Fine-tuning the fit is critical to optimizing ergonomics and improving personal comfort. Acuity's controls are well-marked, easy-to-find tabs, located along the sides of the seat so they're simple to see, use, and understand. Now you'll never have to get out of your seat or fuss with paddles and knobs to adjust your chair.

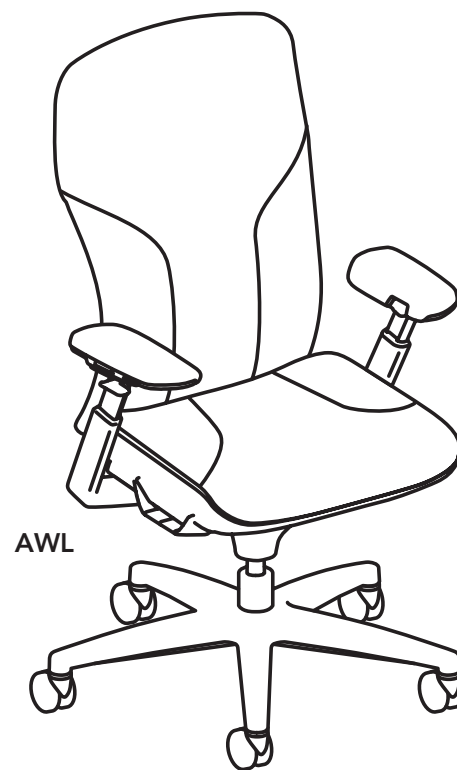

Materials and Finishes

Acuity has been designed to complement any interior design, any organizational aesthetic. Purity of form, sensual lines, and a slender profile let it make a supportive statement to every environment, every body. Choose from several classic colors for chassis, base, caster, mesh carrier, and mesh and a wide variety of standard and partnership upholstery options.

Optional Upholstered Jacket

Dress for success with a slip on jacket that offers premium appeal in conference areas, private offices, or the boardroom. Elegantly tailored with a simple snap closure and seven stitches per inch, architects and interior designers can choose from jackets in leather options. Remove the jacket and you're back to mesh for everyday flexibility, anywhere in the office.

Casters

Black dual-wheel hard tread casters for carpet are standard.

Optional multi-surface casters provide smooth functioning on any surface, from a carpeted conference room to polished concrete. Finishes that match bases in standard black, graphite, or polished aluminum give Acuity head-to-toe elegance.

Fully Adjustable Arms

Intuitive controls let you find any of the eight arm positions. A single lever releases the arms to slide up or down; a button right where the thumb naturally lands lets you move the arm pad inward or outward, forward or backward. You can also pivot the front of the arm pads inward to move in closer to your desk and offer support while working.

Fixed Arms

Provide basic support for people who face a varied work day. Fixed arms limit adjustability and maintain aesthetics in conference room settings. Acuity's Fixed T Arms are 100% cast aluminum.

Materials

- All upholstery foams are CFC-free.
- All COMs/COLs must be approved for upholsterability or applicable fire code compliance prior to order entry. See pages 6-8 for COM ordering information.
- Flammability code compliance of Allsteel textiles and seating is listed on pages 17-19. COM/COL manufacturers supply certificates of compliance for fabric-only tests such as CAL TB117-2013. Allsteel must test a complete chair to supply a certificate with CTB 133.

Acuity meets the requirements set forth in ANSI/BIFMA X5.1-2011 and BIFMA G1-2013. Acuity is warranted for multiple shifts and users up to 300 lbs.

OPTIONS — ACUITY:**Armrests:**

- W** Fully Adjustable Arms **A** Armless
F Fixed Arms

Jacket:

- M** (None)

Chassis:

- G** Graphite Chassis
S Silver Chassis
W Brilliant White (limited to Titanium frames)
P Polished Aluminum Chassis

Back Frame/Mesh:

- GC** Graphite Carrier/Clay Mesh
GD Graphite Carrier/Dusk Mesh
TL Titanium Carrier/Lustre Mesh
TM Titanium Carrier/Mist Mesh

Fire Code:

- NO** Standard Upholstery, No Fire Code

Base:

- P71** Black Polymer Base
P85 Graphite Painted Aluminum Base (\$161 extra)
PR6 Silver Painted Aluminum Base (\$161 extra)
PQ8 Brilliant White Painted Aluminum Base (\$161 extra)
PAL Polished Aluminum Base (\$240 extra)

Pneumatic Cylinder:

- 2** Standard; allows 5" of travel
3 Short; non-standard 3½" of travel to meet BIFMA G1-2002

Casters:

- H** Black Dual-Wheel Hard Tread for carpet
B Black Multi-Surface (\$109 extra)
T Titanium Multi-Surface (\$109 extra)
P Polished Aluminum Multi-Surface (\$147 extra)

Upholstery:

See pages 50-51 for Centurion model.

See pages 13-14 for other upholstery selections.

See pages 17-19 for colors and codes

▲ Indicates upholstery available for Acuity jacket

Armpads

- S** Standard Polyurethane Armpad

Jacket — Acuity jacket models are subject to creases and gathers. Selection includes a subset of the Standard Options to optimize customer satisfaction.







NOTE: Not all options listed above are available on all models. See pages 50-51 for options by model.

Seating — Work

• Features and adjustments on all Acuity models: Conforming Mesh Back, AcuFit® Tilt Lock with Recline Tension, Seat Depth, and Pneumatic Adjustment

GSA SIN 33721

(See page 146 for COM pricing on Grades 9-22)

Armrest	Jacket Material	Chassis Finish	Model Number Add options below	Model Number								Leather				
				1	2	3	4	5	6	7	8	1*	2*			
Fully Adjustable Arms  	Leather	Graphite	AWLG	—	—	—	—	—	—	—	—	—	—	\$ 4608	\$ 5232	
		Silver	AWLS	—	—	—	—	—	—	—	—	—	—	—	\$ 4608	\$ 5232
		Brilliant White*	AWLW	—	—	—	—	—	—	—	—	—	—	—	\$ 4608	\$ 5232
		Polished Aluminum	AWLP	—	—	—	—	—	—	—	—	—	—	—	\$ 5197	\$ 5821
	(None)	Graphite	AWMG	\$ 2766	\$ 2815	\$ 2860	\$ 2907	\$ 2953	\$ 2998	\$ 3046	\$ 3090	\$ 3342	\$ 3623			
		Silver	AWMS	\$ 2766	\$ 2815	\$ 2860	\$ 2907	\$ 2953	\$ 2998	\$ 3046	\$ 3090	\$ 3342	\$ 3623			
		Brilliant White*	AWMW	\$ 2766	\$ 2815	\$ 2860	\$ 2907	\$ 2953	\$ 2998	\$ 3046	\$ 3090	\$ 3342	\$ 3623			
		Polished Aluminum	AWMP	\$ 3357	\$ 3406	\$ 3451	\$ 3498	\$ 3544	\$ 3589	\$ 3637	\$ 3681	\$ 3933	\$ 4214			
		Graphite with Centurion	VATWVG	\$ 2572	—	—	—	—	—	—	—	—	—			
Fixed Arms  	Leather	Graphite	AFLG	—	—	—	—	—	—	—	—	—	\$ 4720	\$ 5344		
		Silver	AFLS	—	—	—	—	—	—	—	—	—	—	\$ 4720	\$ 5344	
		Brilliant White*	AFLW	—	—	—	—	—	—	—	—	—	—	\$ 4720	\$ 5344	
		Polished Aluminum	AFLP	—	—	—	—	—	—	—	—	—	—	\$ 5310	\$ 5934	
	(None)	Graphite	AFMG	\$ 2878	\$ 2927	\$ 2972	\$ 3019	\$ 3065	\$ 3110	\$ 3158	\$ 3202	\$ 3454	\$ 3735			
		Silver	AFMS	\$ 2878	\$ 2927	\$ 2972	\$ 3019	\$ 3065	\$ 3110	\$ 3158	\$ 3202	\$ 3454	\$ 3735			
		Brilliant White*	AFMW	\$ 2878	\$ 2927	\$ 2972	\$ 3019	\$ 3065	\$ 3110	\$ 3158	\$ 3202	\$ 3454	\$ 3735			
		Polished Aluminum	AFMP	\$ 3467	\$ 3516	\$ 3561	\$ 3608	\$ 3654	\$ 3699	\$ 3747	\$ 3791	\$ 4043	\$ 4324			
Armless  	Leather	Graphite	AALG	—	—	—	—	—	—	—	—	—	\$ 4394	\$ 5018		
		Silver	AALS	—	—	—	—	—	—	—	—	—	—	\$ 4394	\$ 5018	
		Brilliant White*	AALW	—	—	—	—	—	—	—	—	—	—	\$ 4394	\$ 5018	
		Polished Aluminum	AALP	—	—	—	—	—	—	—	—	—	—	\$ 4983	\$ 5607	
	(None)	Graphite	AAMG	\$ 2552	\$ 2601	\$ 2646	\$ 2693	\$ 2739	\$ 2784	\$ 2832	\$ 2876	\$ 3128	\$ 3409			
		Silver	AAMS	\$ 2552	\$ 2601	\$ 2646	\$ 2693	\$ 2739	\$ 2784	\$ 2832	\$ 2876	\$ 3128	\$ 3409			
		Brilliant White*	AAMW	\$ 2552	\$ 2601	\$ 2646	\$ 2693	\$ 2739	\$ 2784	\$ 2832	\$ 2876	\$ 3128	\$ 3409			
		Polished Aluminum	AAMP	\$ 3142	\$ 3191	\$ 3236	\$ 3283	\$ 3329	\$ 3374	\$ 3422	\$ 3466	\$ 3718	\$ 3999			

*Brilliant White models limited to Titanium frame finish.

Continued on next page ►

<p>How to specify — Select the Model Number from above.</p>	<p>1st Option: Select the Frame/Mesh Color:</p> <p>GC Graphite/Clay Mesh GD Graphite/Dusk Mesh TL Titanium/Lustre Mesh TM Titanium/Mist Mesh</p> <p>(Brilliant White models limited to Titanium frame finish. VATWVG model limited to Graphite/Dusk.)</p>	<p>2nd Option: Select the Fire Code:</p> <p>NO</p>	<p>3rd Option: Select the Base Color:</p> <p>P71 Black Polymer P85 Graphite Painted Aluminum (\$161 extra) PR6 Silver Painted Aluminum (\$161 extra) PQ8 Brilliant White Painted Aluminum (\$161 extra) PAL Polished Aluminum (\$240 extra)</p> <p>(VATWVG model limited to P71 Black Polymer)</p>
		.	.

Examples: VATWVGGDNO.P71.2.H.CU10

Model Number	COM Yandage				Overall				Seat				Armrests				Backrest					
	COL Sp. Feet Seat	COL Sp. Feet Back	COL Sp. Feet Arms	Height (Range)	Width	Depth	Height Standard (Range)	Height Slant (Range)	Width	Depth (Range)	Pan Angle (Range)	Height Standard (Range)	Width Between Armrests (Range)	Depth (Range)	Pivot Inwards	Pivot Outwards	Height	Width	Lumbar Height (Initial)	Backrest Height (Range)	Backrest Angle	Ship Weight
AWLG	—	11.2	14	4	41-46½"	26½"	25"	16½-21¼"	19"	15½-18½"	2.5°-9.5°	7-11"	12½-20½"	8¼-13¼"	25°	—	25½"	16"	8½"	93.5°-111°	64.0	21.7
AWLS	—	11.2	14	4	41-46½"	26½"	25"	16½-21¼"	19"	15½-18½"	2.5°-9.5°	7-11"	12½-20½"	8¼-13¼"	25°	—	25½"	16"	8½"	93.5°-111°	64.0	21.7
AWLW	—	11.2	14	4	41-46½"	26½"	25"	16½-21¼"	19"	15½-18½"	2.5°-9.5°	7-11"	12½-20½"	8¼-13¼"	25°	—	25½"	16"	8½"	93.5°-111°	64.0	21.7
AWLP	—	11.2	14	4	41-46½"	26½"	25"	16½-21¼"	19"	15½-18½"	2.5°-9.5°	7-11"	12½-20½"	8¼-13¼"	25°	—	25½"	16"	8½"	93.5°-111°	64.0	21.7
AWMG	1.0	11.2	—	4	41-46½"	26½"	25"	16½-21¼"	19"	15½-18½"	2.5°-9.5°	7-11"	12½-20½"	8¼-13¼"	25°	—	25½"	16"	8½"	93.5°-111°	64.0	21.7
AWMS	1.0	11.2	—	4	41-46½"	26½"	25"	16½-21¼"	19"	15½-18½"	2.5°-9.5°	7-11"	12½-20½"	8¼-13¼"	25°	—	25½"	16"	8½"	93.5°-111°	64.0	21.7
AWMW	1.0	11.2	—	4	41-46½"	26½"	25"	16½-21¼"	19"	15½-18½"	2.5°-9.5°	7-11"	12½-20½"	8¼-13¼"	25°	—	25½"	16"	8½"	93.5°-111°	64.0	21.7
AWMP	1.0	11.2	—	4	41-46½"	26½"	25"	16½-21¼"	19"	15½-18½"	2.5°-9.5°	7-11"	12½-20½"	8¼-13¼"	25°	—	25½"	16"	8½"	93.5°-111°	64.0	21.7
VATWVG	—	—	—	—	41-46½"	26½"	25"	16½-21¼"	19"	15½-18½"	2.5°-9.5°	7-11"	12½-20½"	8¼-13¼"	25°	—	25½"	16"	8½"	93.5°-111°	64.0	21.7
AFLG	—	11.2	14	4	41-46½"	26½"	25"	16½-21¼"	19"	15½-18½"	2.5°-9.5°	9"	19¼"	11½"	—	—	25½"	16"	8½"	93.5°-111°	64.0	21.7
AFLS	—	11.2	14	4	41-46½"	26½"	25"	16½-21¼"	19"	15½-18½"	2.5°-9.5°	9"	19¼"	11½"	—	—	25½"	16"	8½"	93.5°-111°	64.0	21.7
AFLW	—	11.2	14	4	41-46½"	26½"	25"	16½-21¼"	19"	15½-18½"	2.5°-9.5°	9"	19¼"	11½"	—	—	25½"	16"	8½"	93.5°-111°	64.0	21.7
AFLP	—	11.2	14	4	41-46½"	26½"	25"	16½-21¼"	19"	15½-18½"	2.5°-9.5°	9"	19¼"	11½"	—	—	25½"	16"	8½"	93.5°-111°	64.0	21.7
AFMG	1.0	11.2	—	4	41-46½"	26½"	25"	16½-21¼"	19"	15½-18½"	2.5°-9.5°	9"	19¼"	11½"	—	—	25½"	16"	8½"	93.5°-111°	64.0	21.7
AFMS	1.0	11.2	—	4	41-46½"	26½"	25"	16½-21¼"	19"	15½-18½"	2.5°-9.5°	9"	19¼"	11½"	—	—	25½"	16"	8½"	93.5°-111°	64.0	21.7
AFMW	1.0	11.2	—	4	41-46½"	26½"	25"	16½-21¼"	19"	15½-18½"	2.5°-9.5°	9"	19¼"	11½"	—	—	25½"	16"	8½"	93.5°-111°	64.0	21.7
AFMP	1.0	11.2	—	4	41-46½"	26½"	25"	16½-21¼"	19"	15½-18½"	2.5°-9.5°	9"	19¼"	11½"	—	—	25½"	16"	8½"	93.5°-111°	64.0	21.7
AALG	—	11.2	14	—	41-46½"	26½"	25"	16½-21¼"	19"	15½-18½"	2.5°-9.5°	—	—	—	—	—	25½"	16"	8½"	93.5°-111°	55.0	21.7
AALS	—	11.2	14	—	41-46½"	26½"	25"	16½-21¼"	19"	15½-18½"	2.5°-9.5°	—	—	—	—	—	25½"	16"	8½"	93.5°-111°	55.0	21.7
AALW	—	11.2	14	—	41-46½"	26½"	25"	16½-21¼"	19"	15½-18½"	2.5°-9.5°	—	—	—	—	—	25½"	16"	8½"	93.5°-111°	55.0	21.7
AALP	—	11.2	14	—	41-46½"	26½"	25"	16½-21¼"	19"	15½-18½"	2.5°-9.5°	—	—	—	—	—	25½"	16"	8½"	93.5°-111°	55.0	21.7
AAMG	1.0	11.2	—	—	41-46½"	26½"	25"	16½-21¼"	19"	15½-18½"	2.5°-9.5°	—	—	—	—	—	25½"	16"	8½"	93.5°-111°	55.0	21.7
AAMS	1.0	11.2	—	—	41-46½"	26½"	25"	16½-21¼"	19"	15½-18½"	2.5°-9.5°	—	—	—	—	—	25½"	16"	8½"	93.5°-111°	55.0	21.7
AAMW	1.0	11.2	—	—	41-46½"	26½"	25"	16½-21¼"	19"	15½-18½"	2.5°-9.5°	—	—	—	—	—	25½"	16"	8½"	93.5°-111°	55.0	21.7
AAMP	1.0	11.2	—	—	41-46½"	26½"	25"	16½-21¼"	19"	15½-18½"	2.5°-9.5°	—	—	—	—	—	25½"	16"	8½"	93.5°-111°	55.0	21.7

Dimensions are in accordance with BIFMA G1-2013 guidelines — see illustration of guidelines on page 45.

◀ Continued from previous page

<p>4th Option: Select the Cylinder:</p> <p>2 Standard, allows 5" of travel</p> <p>3 Short, allows 3½" of travel</p> <p>(VATWVG model limited to 2 standard cylinders)</p>	<p>5th Option: Select the Casters:</p> <p>H Black Dual-Wheel Hard Tread for carpet</p> <p>B Black Multi-Surface (\$109 extra)</p> <p>T Titanium Multi-Surface (\$109 extra)</p> <p>P Polished Aluminum Multi-Surface (\$147 extra)</p> <p>(VATWVG model limited to H Black Dual-Wheel Hard Tread for carpet)</p>	<p>6th Option: Select the Upholstery:</p> <p>See pages 13-14 for selections.</p> <p>See pages 6-8 for COM guidelines.</p> <p>(VATWVG model limited to CU Centurion upholstery)</p>	<p>7th Option: Select the Armpad:</p> <p>S Standard Poly Armpads</p>
--	---	---	--

Acuity side chairs provide an ideal solution for busy work areas such as training rooms, gathering areas, informal conferencing, cafés, and more. With a stackable design and pivoting back, Acuity side chairs provide the perfect combination of versatility and unexpected comfort.

MODELS AND OPTIONS

Acuity offers side chair models with mesh backs in two frame colors.

Side chairs feature **arm and armless models** with casters or glides.

Glides are available in nylon, nickel-plated, or felt options. Nylon glides are recommended for hard surfaces, commercial carpet, and damp environments. Nickel-plated glides are recommended for carpet. Felt glides are recommended for wood, tile, or high-shine floor surfaces.

Multi-surface casters are also available.

Chairs ship up to two per carton to minimize waste.

CONSTRUCTION

Steel frames and structural moldings create a durable design that performs in a variety of environments.

Seat upholstery is easily field replaceable allowing users to extend the lifecycle of the chairs.

Multi-purpose side chairs **stack up to 4-high** on the floor.

Acuity mesh chairs feature Acuity Mesh. This construction provides responsive, conforming back support and an open, airy aesthetic.

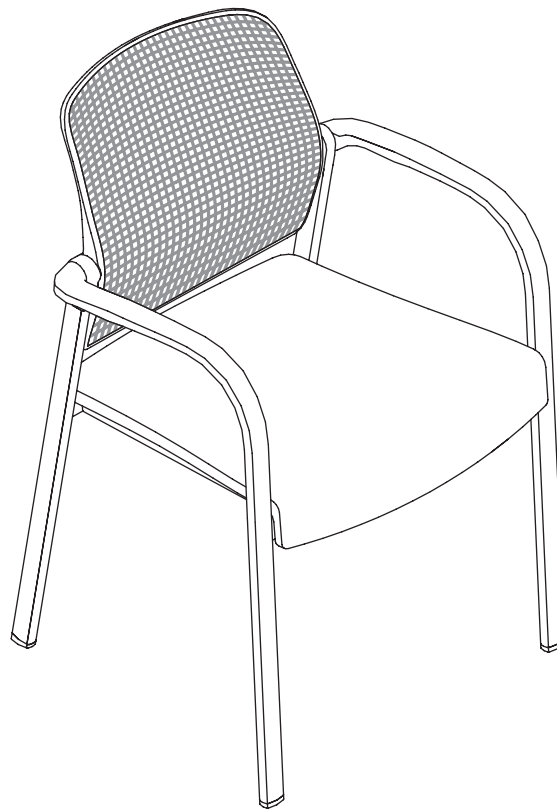

ACM-MUGO — Mesh Back and Upholstered Seat

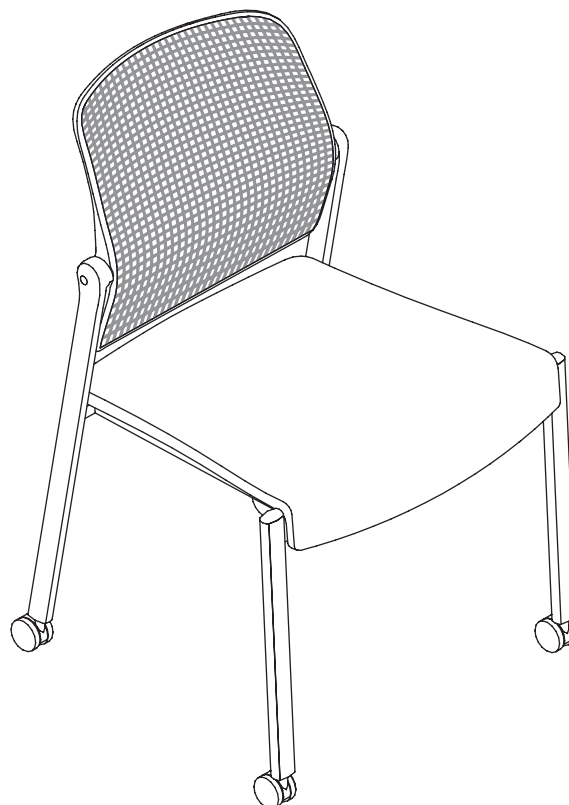

ACM-MUCA — Mesh Back and Upholstered Seat

UPHOLSTERY AND CONTOURING

Acuity side chairs feature a pivoting back that provides unexpected comfort in any application. The **pivoting back** provides support while encouraging movement that makes for healthy sitting. The **backrest** features a contoured lumbar support to help relieve stress on the back. Added movement and support allow the Acuity multi-purpose side chair to go from project conference rooms to teaming areas to training rooms with ease.

The upholstered seat features a generous 2" of high-resiliency molded foam padding for comfort and long-term support.

All upholstery foams are **CFC-free**.

All **COMs/COLs** must be approved for upholsterability or applicable fire code compliance prior to order entry. See COM ordering instructions on pages 6-8.

Flammability code compliance of Allsteel textiles and seating is listed on pages 13-14. COM/COL manufacturers supply certificates of compliance for fabric-only tests such as CAL TB117-2013.

Acuity meets the requirements set forth in ANSI/BIFMA X5.1-2011. Acuity side chairs are warranted for users up to 300 lbs.

OPTIONS — ACUITY MULTI-PURPOSE SIDE:

Versions include arm and armless models with glides or casters with an upholstered seat and mesh back.

Back Type:

M Mesh

Seat Type:

U Upholstered

Frame Type:

C Casters

G Glides

Arm Option:

O Arms (Arm color will match carrier color — black or titanium)

A Armless

Glides/Casters:

0 Nylon Glides for hard surfaces and commercial carpet

1 Nickel-plated Glides for carpet (\$19 extra)

2 Felt Glides for wood, tile, or high-sheen surfaces. (\$19 extra)

3 Multi-surface Casters

Frame Color:

P85 Graphite

PR6 Silver

P8X Solar Black

P8T Titanium

Carrier/Mesh Color:

BC Charblack Carrier/Clay Mesh

BD Charblack Carrier/Dusk Mesh



TL Titanium Carrier/Lustre Mesh

TM Titanium Carrier/Mist Mesh

Select the Upholstery:

See pages 13-14 for selections and see pages 17-19 for colors and codes.

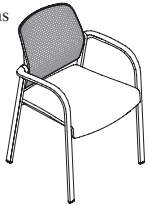
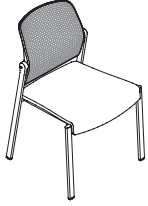
(See page 146 for COM pricing on Grades 9-22)

Overall Size Armrest	Adjustments and Features	Back Type	Model Number <i>Add options below</i>									Leather	
				1	2	3	4	5	6	7	8	1	2
GLIDES Arms	Pivot Back	Mesh	ACM-MUGO	\$ 1172	\$ 1205	\$ 1238	\$ 1280	\$ 1321	\$ 1363	\$ 1403	\$ 1445	\$ 1895	\$ 3120
													
Armless	Pivot Back	Mesh	ACM-MUGA	\$ 1104	\$ 1137	\$ 1170	\$ 1212	\$ 1253	\$ 1295	\$ 1335	\$ 1377	\$ 1827	\$ 3052
													
CASTERS Arms	Pivot Back	Mesh	ACM-MUCO	\$ 1263	\$ 1296	\$ 1329	\$ 1371	\$ 1412	\$ 1454	\$ 1494	\$ 1536	\$ 1986	\$ 3211
													
Armless	Pivot Back	Mesh	ACM-MUCA	\$ 1195	\$ 1228	\$ 1261	\$ 1303	\$ 1344	\$ 1386	\$ 1426	\$ 1468	\$ 1918	\$ 3143
													

NOTE: Acuity side chairs ship two per carton to minimize waste. Model numbers and prices are per chair.

ACUITY

<p>How to specify — Select the Model Number from above.</p>	<p>1st Option: Select the Glides/Casters:</p> <ul style="list-style-type: none"> 0 Nylon Glides 1 Nickel-plated Glides for carpet (\$19 extra) 2 Felt Glides (\$19 extra) 3 Multi-surface Casters 	<p>2nd Option: Select the Frame Color:</p> <ul style="list-style-type: none"> P85 Graphite PR6 Silver P8X Solar Black P8T Titanium 	<p>3rd Option: Select the Mesh Frame / Mesh Color:</p> <ul style="list-style-type: none"> BC Charblack Carrier/Clay Mesh BD Charblack Carrier/Dusk Mesh TL Titanium Carrier/Lustre Mesh TM Titanium Carrier/Mist Mesh 	<p>4th Option: Select the Upholstery:</p> <p>See pages 13-14 for selections and pages 17-19 for colors and codes. See pages 6-8 for COM guidelines.</p>
<p>ACM-MU</p>				

Examples: ACM-MUCA.3.P85.BD.PNS012 ACM-MUGA.2.P85.BM.STX13

Model Number	COM Yachage			Overall			Seat			Armrests				Backrest						
	COL Sp. Feet	Height	Width	Depth	Height	Width	Depth	Pan Angle	Armrest Height	Width Between Armrests	Armrest Length	Arm Height to the Floor	Height	Width	Lumbar Height	Backrest/Seat Angle (Range)	Ship Weight	Ship Weight Per Carton	Cubes	
ACM-MUGO	1.0	11.5	33½"	24½"	21½"	18½"	18"	16"	8°	9¼"	20½"	7½"	26½"	18½"	16½"	9¼"	96°-99°	24	—	13.2
ACM-MUGA	1.0	11.5	33½"	22½"	21½"	18½"	18"	16"	8°	—	—	—	—	18½"	16½"	9¼"	96°-99°	24	—	13.2
ACM-MUCO	1.0	11.5	33½"	24½"	21½"	18½"	18"	16"	8°	9¼"	20½"	7½"	26½"	18½"	16½"	9¼"	96°-99°	24	—	13.2
ACM-MUCA	1.0	11.5	33½"	22½"	21½"	18½"	18"	16"	8°	—	—	—	—	18½"	16½"	9¼"	96°-99°	24	—	13.2

NOTE: Acuity side chairs ship two per carton to minimize waste. Model numbers and prices are per chair.

Clarity offers a clean, simple design that preserves only the essential elements of form and function. Designed in collaboration with BMW Group DesignworksUSA, Clarity combines a pure, honest aesthetic that transcends the floor plan with an unexpected comfort that anticipates your every posture.

Form

The streamlined design creates a unique visual interest that inspires your imagination without distracting your focus. Clarity's frame and base are constructed of aluminum, offering superior quality and durability. Wherever you work, it goes.

Function

The continuous mesh seat and back offer instant comfort and support with minimal adjustment. You can sit upright. Side sit. Turn around. Or lean over the back. With no fussing and less fine-tuning. Anywhere you go, and any way you sit, it works.

Versatility

Because form and function are simplified, Clarity adapts to any space you're in, as well as any type of work you're doing. From focused heads-down work to engaged collaboration to active lounging. It's always a reflection of the space it's in and the people who use it.



C50MFC

DESIGN FEATURES

Clarity seating is engineered to support a variety of work, conference, and lounge applications that share a simple, intuitive, and active design.

Fixed Arms

Provide basic support for users engaging in a variety of tasks throughout the day. Arms come with protective urethane arm pads. Fixed arms limit adjustability but provide consistent aesthetics in conference room settings.

Arm Covers

Sleeves are made of 1/8" thick santoprene and are available in G Graphite or T Titanium.

Pneumatic Seat Height Adjustment

Regulates height of work chair relative to the floor. Standard 5" of travel accommodates average to tall users.

Base/Casters/Glides

Work chair bases are a five-star design, C5 models are aluminum and polymer base work models are composite. Dual-wheel casters are available in hard tread for carpet.

Materials

- All models meet CAL133.
- All COLs must be approved for upholsterability or applicable fire code compliance prior to order entry. See pages 6-8 for COM ordering instructions.
- Allsteel fabrics meet requirements for CAL TB117-2013. COM/COL manufacturers supply certificates of compliance for fabric-only tests such as CAL TB117-2013.
- Clarity is warranted for multiple shifts and users up to 300 lbs.

OPTIONS — CLARITY

Chair Type:

C5 Work

Armrests:

Fixed Arms

Jacket:

M None (mesh chair)

Mesh Color:

CM20 Flint

CM22 Graphite

CM23 Platinum

Frame Color:

P4Q Carbon

PR6 Silver (add \$38)

Mesh Carrier and Arm Pads:

G Graphite

T Titanium

Base:

P4Q Carbon

PR6 Silver (add \$25)

Pneumatic Cylinder:

2 Work, allows 5" of travel

Casters:

BHT Black Hard Tread Casters for carpets

Model	Armrest	Jacket	Model Number <i>Add options below</i>	List Price
Work	Arms	None	C5OMFC	\$ 1509



Continued on next page ►

<p>How to specify — Select the Model Number from above.</p> <p>C .</p>	<p>1st Option Select the Mesh Color (if applicable):</p> <p>CM20 Flint CM22 Graphite CM23 Platinum</p> <p> .</p>	<p>2nd Option: Select the Frame Color (if applicable):</p> <p>P4Q Carbon PR6 Silver (\$38 extra)</p> <p> .</p>	<p>3rd Option: Select the Mesh Carrier Frame and Arm Pads Color (if applicable):</p> <p>G Graphite T Titanium</p> <p> .</p>	<p>4th Option: Select the Base Color (if applicable):</p> <p>P4Q Carbon PR6 Silver (\$25 extra)</p> <p> .</p>
---	--	--	---	---

Examples: C5OMFC.CM21.PR6.G.PR6.2.BHT

Model Number	Overall			Seat			Armrests			Backrest			Ship Weight	Ship Weight Per Carton	Cubes					
	COM Yachage*	COL Sp. Per**	Height (Range)	Width	Depth	Height (Range)	Width	Depth	Pan Angle (Range)	Armrest Height	Width Between Armrests	Armrest Length				Arm Height to the Floor	Height	Width	Lumbar Height	Backrest/Seat Angle (Range)
C5OMFC	—	—	32½-37½"	25"	26"	15½ - 20½"	19"	16½"	4.7° - 5.3°	9½"	21"	11½"	25-30"	19½"	19"	9½"	98°-110°	41	—	11.1

◀ Continued from previous page

<p><i>5th Option:</i> Select the Cylinder (if applicable): 2 Work</p>	<p><i>6th Option:</i> Select the Casters (if applicable): BHT Black Hard Tread for carpet</p>
---	---

People are moving around the workspace to get work done, and the conference room or shared bench is the home away from home. The Evo collection is adaptable and interchangeable across multiple spaces to provide consistent comfort while maintaining a cohesive design.

KEY FEATURES

Evo chairs feature weight-activated recline so there's no additional tension adjustment. Intuitive controls, along with specially sculpted and formulated seat foam, create a comfortable sitting experience for wherever and however people work.

Arms

Open arms allow for multiple sitting postures and remain lateral when reclining for maximum support. Options for work and conference models: 4D adjustable arms, height-adjustable arms, fixed polished aluminum arms, or armless.

Accent stitching

Accent stitching, available in nine colors, offers a way to make a design statement on work and conference models.

Back support

Contoured frame provides upright back support. Optional user-adjustable lumbar can be added at any time.

Up-front controls

Integrated, up-front controls are easy to access and use and contribute to an overall clean aesthetic.

Height-Adjustable Footring

Travels 8" to ensure users have comfortable support of their feet and legs. The footring has a 20" diameter.

MATERIALS

All COMs/COLs must be approved for upholsterability or applicable fire code compliance prior to order entry. See pages 6-8 for COM ordering instructions.

Allsteel fabrics meet requirements for CTB117. COM/COL manufacturers supply certificates of compliance for fabric-only tests such as CTB117.

Evo meets the requirements set forth in ANSI/BIFMA X5.1-2011 and BIFMA G1-2013. Evo is warranted for multiple shifts and users up to 300 lbs.

Evo Side Chair is warranted for users up to 300 lbs.

4D adjustable arms

Evo's 4D arms are fully adjustable in height, width, depth, and can pivot to provide optimal support. Pivot the front of the arm pads inward to move in closer to your desk and offer support while working.

Height-adjustable arms

Provides height adjustments for optimal support of elbows and shoulders while keyboarding or conferencing while providing ease of entry/exit.

Fixed polished aluminum arms

Provide basic support for users engaging in a variety of tasks throughout the day. Arms come with protective black, flint, titanium or salt urethane arm pads to match the specified frame finish. Fixed arms limit adjustability but provide consistent aesthetics in conference room settings.

Optional adjustable lumbar support

To accommodate personal preference, an optional external lumbar support can be added at any time with 4" range of adjustment.

Base and casters

Work chair bases are a five-star design. Dual-wheel casters are available in hard tread for carpet, or multi-surface for any floor surface.



DWW-MHWNO
Work



DWC-UMWNO
Conference

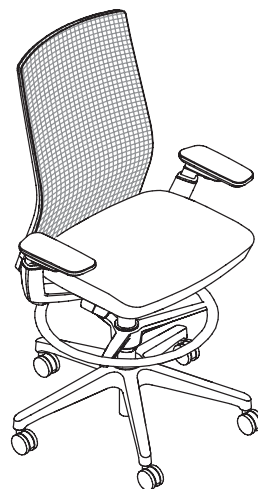

DWS-MHWNO
Stool

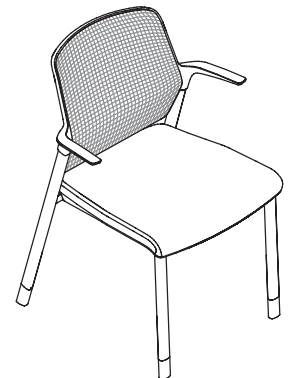

DSC-MUGONO
Side Chair

SIDE CHAIR MODELS AND OPTIONS

Evo offers side chair models in four frame colors with mesh backs in five colors. Side chairs feature arms with casters or glides. Glides are available in nylon, nickel-plated, or felt options. Nylon glides are recommended for hard surfaces, commercial carpet, and damp environments. Nickel-plated glides are recommended for carpet. Felt glides are recommended for wood, tile, or high-sheen floor surfaces. Multi-surface casters are also available. Chairs ship up to three per carton to minimize waste. Evo Side chair can be stacked up to four high.

OPTIONS — WORK/CONFERENCE/STOOL

Chair Type:

- DWW** Work
- DWC** Conference
- DWS** Stool

Back Type:

- M** Mesh (Work/Stool)
- U** Upholstered (Conference)

Overall Size:

- H** High-Back (Work/Stool)
- M** Mid-Back (Conference)

Arms:

- W** 4D Adjustable Arms
- H** Height Adjustable Arms
- F** Fixed Polished Aluminum Arms
- A** No Arms

Fire Code:

- NO** No Fire Code

Frame Color (Work/Conference/Stool):

- BLK** Black
- E9** Flint (add \$91)
- ST** Salt (add \$91)
- TI** Titanium (add \$46)

Mesh Color (Work, Stool, Side):

- C** Clay **M** Mist
- D** Dusk **N** Navy
- L** Lustre

Lumbar (Work, Stool):

- L** Yes (\$57 extra) **N** No

Cylinder:

- 2** Standard, allows 5" of Travel
- 3** Short, allows 2½" of Travel
- 4** Stool, allows 10" of Travel

Base Color:

- BLK** Black
- E9** Flint
- ST** Salt
- TI** Titanium
- PAL** Polished Aluminum (\$164 extra)

Casters:

- H** Black Hard Tread
- B** Black Multi-Surface (\$68 extra)
- E9** Flint Multi-Surface (\$68 extra)
- ST** Salt Multi-Surface (\$68 extra)
- T** Titanium Multi-Surface (\$68 extra)
- PAL** Polished Aluminum Multi-Surface (\$147 extra)

Upholstery:

See pages 13-14 for selections, colors, and codes.

Accent Stitching:

Accent stitching for seat (\$36 extra) and for Conference back (\$87 extra). See thread color/code options on page 63. Variance in accent stitch consistency in linearity should be expected based on material specifications.

Pad Color for Lumbar is **TGR** Translucent Graphite.

OPTIONS — SIDE CHAIR

Chair Type:

- DSC** Side Chair

Back Type:

- M** Mesh

Seat Type:

- U** Upholstered

Casters/Glides:

- C** Casters
- G** Glides

Arm Option:

- O** Fixed Arms

Fire Code:

- NO** No Fire Code

Frame Color:

- P8X** Solar Black (side)
- P8T** Titanium (side)
- P71** Black (side)
- P02** Flint (side)
- P8C** Salt (side)
- PR6** Silver (side)

Mesh Color:

- C** Clay **M** Mist
- D** Dusk **N** Navy
- L** Lustre





Glides/Casters:

- 0** Nylon Glides
- 1** Nickel Glides (\$19 extra)
- 2** Felt Glides (\$19 extra)
- 3** Multi-Surface Casters

Seat Upholstery:

See pages 13-14 for selections, colors, and codes.

Upcharges listed for Grades 2 and above, add to Base Price. Grades 9-22 on page 146.

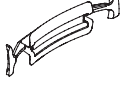
Armrest	Back	Model Number	Base Price	Upholstery	Upcharge								Leather	
					2	3	4	5	6	7	8	1	2	
	Work Mesh High-Back	DWW-MHWNO	\$ 1651	Seat	\$ 24	\$ 44	\$ 66	\$ 90	\$ 116	\$ 136	\$ 164	\$ 355	\$ 573	
	Conference Upholstered Mid-Back	DWC-UMWNO	\$ 1864	Seat	\$ 24	\$ 44	\$ 66	\$ 90	\$ 116	\$ 136	\$ 164	\$ 355	\$ 573	
				Back	\$ 37	\$ 65	\$ 98	\$ 134	\$ 173	\$ 205	\$ 246			
	Work Mesh High-Back	DWW-MHHNO	\$ 1575	Seat	\$ 24	\$ 44	\$ 66	\$ 90	\$ 116	\$ 136	\$ 164	\$ 355	\$ 573	
	Conference Upholstered Mid-Back	DWC-UMHNO	\$ 1789	Seat	\$ 24	\$ 44	\$ 66	\$ 90	\$ 116	\$ 136	\$ 164	\$ 355	\$ 573	
				Back	\$ 37	\$ 65	\$ 98	\$ 134	\$ 173	\$ 205	\$ 246			
	Work Mesh High-Back	DWW-MHFNO	\$ 1627	Seat	\$ 24	\$ 44	\$ 66	\$ 90	\$ 116	\$ 136	\$ 164	\$ 355	\$ 573	
	Conference Upholstered Mid-Back	DWC-UMFNO	\$ 1839	Seat	\$ 24	\$ 44	\$ 66	\$ 90	\$ 116	\$ 136	\$ 164	\$ 355	\$ 573	
				Back	\$ 37	\$ 65	\$ 98	\$ 134	\$ 173	\$ 205	\$ 246			
*Requires PAL Base Color														
	Work Mesh High-Back	DWW-MHANO	\$ 1452	Seat	\$ 24	\$ 44	\$ 66	\$ 90	\$ 116	\$ 136	\$ 164	\$ 355	\$ 573	
	Conference Upholstered Mid-Back	DWC-UMANO	\$ 1664	Seat	\$ 24	\$ 44	\$ 66	\$ 90	\$ 116	\$ 136	\$ 164	\$ 355	\$ 573	
				Back	\$ 37	\$ 65	\$ 98	\$ 134	\$ 173	\$ 205	\$ 246			
		DW-LUK	\$ 98											

Example of upcharges: Conference Upholstered Mid-Back Model **DWC-UMWNO** with Grade 2 Seat and Grade 5 Back = \$1864 + \$24 + \$134 = \$2022 Total (Plus any additional for options with upcharges selected below.)

Continued on next page ▶

How to specify — Select the Model Number from above.	1st Option: Select the Frame Color:	2nd Option: Select the Mesh Color for Work Chairs (if applicable):	3rd Option: Lumbar for Work Chairs (if applicable):	4th Option: Select the Cylinder (if applicable):	5th Option: Select the Base Color (if applicable):	6th Option: Select the Casters (if applicable):
DW NO	BLK Black E9 Flint (add \$91) ST Salt (add \$91) TI Titanium (add \$46)	C Clay D Dusk L Lustre M Mist N Navy	L Yes (\$57 extra) N No	2 Standard, 5" of Travel 3 Short, 2½" of Travel	BLK Black E9 Flint ST Salt TI Titanium PAL Polished Aluminum (\$164 extra)	H Black Hard Tread B Black Multi-Surface (\$68 extra) E9 Flint Multi-Surface (\$68 extra) ST Salt Multi-Surface (\$68 extra) T Titanium Multi-Surface (\$68 extra) PAL Polished Aluminum Multi-Surface (\$147 extra)

Examples: DWW-MHWNO.BLK.D.L.2.BLK.B.CU10.TC01 DW-LUK.BLK.TGR

DWC-UMWNO.TI.2.TI.T.CU10.TC09.CU50.TC09

Model Number	COM Package			Overall			Seat			Armrests			Backrest			Ship Weight	Ship Weight Per Carton	Cubes			
	COM Package	COL. Sq. Feet	Height (Range)	Width	Depth	Height (Range)	Width	Depth (Range)	Pan Angle (Range)	Armrest Height	Width Between Arms	Depth (Range)	Pivot Inwards	Pivot Outwards	Height				Width	Lumbar Height*	Backrest/Seat Angle (Range)
DWW-MHWNO	0.75		38½"-43½"	26"	26"	16½"-21½" (Short 15½"-18")	20"	15½"-18½"	3°- 10°	6½"-11½"	12½" - 21"	9½"	30°	30°	24"	16½"	10"	97°- 113°	39	39	11.8
DWC-UMWNO	0.9 0.75		35"-40"	26"	26"	16½"-21½" (Short 15½"-18")	20"	16"-18½"	3°- 10°	6½"-11½"	12½" - 21"	9½"	30°	30°	20¾"	17"	10"	97°- 113°	39	39	11.8
DWW-MHHNO	0.75		38½"-43½"	26"	26"	16½"-21½" (Short 15½"-18")	20"	15½"-18½"	3°- 10°	6½"-10½"	21½"	9½"	Arms to Floor 22½"-31½"		24"	16½"	10"	97°- 113°	39	39	11.8
DWC-UMHNO	0.9 0.75		35"-40"	26"	26"	16½"-21½" (Short 15½"-18")	20"	16"-18½"	3°- 10°	6½"-10½"	21½"	9½"	22½"-31½"		20¾"	17"	10"	97°- 113°	39	39	11.8
DWW-MHFNO	0.75		38½"-43½"	26"	26"	16½"-21½" (Short 15½"-18")	20"	15½"-18½"	3°- 10°	8"	21½"	9½"	24°-29°		24"	16½"	10"	97°- 113°	39	39	11.8
DWC-UMFNO	0.9 0.75		35"-40"	26"	26"	16½"-21½" (Short 15½"-18")	20"	16"-18½"	3°- 10°	8"	21½"	9½"	24°-29°		20¾"	17"	10"	97°- 113°	39	39	11.8
DWW-MHANO	0.75		38½"-43½"	26"	26"	16½"-21½" (Short 15½"-18")	20"	15½"-18½"	3°- 10°						24"	16½"	10"	97°- 113°	37	37	11.1
DWC-UMANO	0.9 0.75		35"-40"	26"	26"	16½"-21½" (Short 15½"-18")	20"	16"-18½"	3°- 10°						20¾"	17"	10"	97°- 113°	37	37	11.1





NOTE: Dimensions are in accordance with BIFMA G1-2013 guidelines - see illustration of guidelines on page 45.

*Optional external lumbar support can be added at any time.

◀ Continued from previous page

<p>7th Option: Select the Seat Upholstery (if applicable): See pages 13-14 for selections and color codes. See pages 6-8 for COM Guidelines.</p>	<p>8th Option: Select the Accent Stitch for Seat (if applicable): (Coordinating no upcharge, all other colors listed \$36 extra) TC00 Coordinating TC05 Light Red TC01 Yellow TC06 Orange TC02 Tan TC07 Medium Green TC03 Natural TC08 Blue TC04 Black TC09 Light Gray See pages 6-8 for COM Guidelines.</p>	<p>9th Option: Select the Back Upholstery for Conference Chairs (if applicable): See pages 13-14 for selections and color codes. See pages 6-8 for COM Guidelines.</p>	<p>10th Option: Select the Accent Stitch for Conference Back (if applicable): (Coordinating no upcharge, all other colors listed \$87 extra) See 8th Option for accent stitch for seat for thread colors and codes.</p>	<p>11th Option: Pad Color for Lumbar only required if ordered separately (if applicable): TGR Translucent Graphite</p>
--	---	--	---	---

(See page 146 for COM pricing on Grades 9-22)

Armrest	Back	Model	1	2	3	4	5	6	7	8	Leather	
											1	2
 4D Arms	Work Stool Mesh High-Back	DWS-MHWNO	\$ 2041	\$ 2065	\$ 2085	\$ 2107	\$ 2131	\$ 2157	\$ 2177	\$ 2205	\$ 2396	\$ 2614
 Height-Adjustable Arms	Work Stool Mesh High-Back	DWS-MHHNO	\$ 1965	\$ 1989	\$ 2009	\$ 2031	\$ 2055	\$ 2081	\$ 2101	\$ 2129	\$ 2320	\$ 2538
 Fixed Arms	Work Stool Mesh High-Back	DWS-MHFNO	\$ 2015	\$ 2039	\$ 2059	\$ 2081	\$ 2105	\$ 2131	\$ 2151	\$ 2179	\$ 2370	\$ 2588
 Armless	Work Stool Mesh High-Back	DWS-MHANO	\$ 1842	\$ 1866	\$ 1886	\$ 1908	\$ 1932	\$ 1958	\$ 1978	\$ 2006	\$ 2197	\$ 2415



Model Number	Overall			Seat			Armrests				Backrest										
	COM Package	COL. Sp. Feet	Height (Range)	Width	Depth	Height (Range)	Width	Depth (Range)	Pan Angle (Range)	Armrest Height	Width Between Arms	Armrest Length	Pivot Inwards	Pivot Outwards	Height	Width	Lumbar Height	Backrest/Seat Angle (Range)	Slip Weight	Slip Weight Per Carton	Cubes
DWS-MHWNO	0.75		46"-55 1/2"	26"	26"	22 1/4"-33 3/4"	20"	15 1/2"-18 1/4"	3°-10°	6 1/4"-11 1/4"	12 1/2"-21"	9 1/4"	30"	30"	24"	16 1/2"	10"	97°-113°	45	45	11.8
DWS-MHHNO	0.75		46"-55 1/2"	26"	26"	22 1/4"-33 3/4"	20"	15 1/2"-18 1/4"	3°-10°	6 1/4"-10 1/2"	21 1/2"	9 1/4"			24"	16 1/2"	10"	97°-113°	45	45	11.8
DWS-MHFNO	0.75		46"-55 1/2"	26"	26"	22 1/4"-33 3/4"	20"	15 1/2"-18 1/4"	3°-10°	8"	21 1/2"	9 1/4"			24"	16 1/2"	10"	97°-113°	45	45	11.8
DWS-MHANO	0.75		46"-55 1/2"	26"	26"	22 1/4"-33 3/4"	20"	15 1/2"-18 1/4"	3°-10°			9 1/4"			24"	16 1/2"	10"	97°-113°	44	44	11.1

How to specify — Select the Model Number from above.	1st Option: Select the Frame Color: BLK Black E9 Flint (add \$91) ST Salt (add \$91) TI Titanium (add \$46)	2nd Option: Select the Mesh Color for Work Stools: C Clay D Dusk L Lustre M Mist N Navy	3rd Option: Select the Lumbar: Y Yes (\$57 extra) N No	4th Option: Select the Cylinder: 4 Stool, allows 10" of travel	5th Option: Select the Base Color: BLK Black E9 Flint ST Salt TI Titanium PAL Polished Aluminum (\$164 extra)	6th Option: Select the Casters: H Black Hard Tread B Black Multi-Surface (\$68 extra) E9 Flint Multi-Surface (\$68 extra) \ ST Salt Multi-Surface (\$68 extra) T Titanium Multi-Surface (\$68 extra) PAL Polished Aluminum (Multi-Surface \$147 extra)
	DWS — MH NO 					

7th Option: Select the Seat Upholstery: See pages 13-14 for selections and color codes. See pages 6-8 for COM Guidelines.	8th Option: Select the Accent Stitch for Seat (if applicable): (Coordinating no upcharge; all other colors listed \$36 extra) TC00 Coordinating TC05 Light Red TC01 Yellow TC06 Orange TC02 Tan TC07 Medium Green TC03 Natural TC08 Blue TC04 Black TC09 Light Gray See pages 6-8 for COM Guidelines.
.	.

Examples: DWS-MHWNO.BLK.D.L.4.BLK.B.CU10.TC01
 DWS-MHANO.TI.C.N.4.TI.T.CU50.TC00

(See page 146 for COM pricing on Grades 9-22)

Armrest	Back	Model	1	2	3	4	5	6	7	8	Leather	
											1	2
CASTERS 	4-Leg Side Chair Mesh Back	DSC-MUCONO	\$ 914	\$ 938	\$ 958	\$ 980	\$1004	\$1030	\$1050	\$1078	\$1150	\$ 1297
GLIDES 	4-Leg Side Chair Mesh Back	DSC-MUGONO	\$ 868	\$ 892	\$ 912	\$ 934	\$ 958	\$ 984	\$1004	\$1032	\$1104	\$ 1251

Model Number	COM Yardage			Overall				Seat			Armrests				Backrest					
	COL	Sq. Feet	Height	Width	Depth	Height	Width	Depth	Pan Angle (Range)	Armrest Height	Width Between Arms	Armrest Length	Armrest Height From Floor	Height	Width	Lumbar Height	Backrest/Seat Angle (Range)	Ship Weight	Ship Weight Per Carton	Cubes
DSC-MUCONO	1.0	11.50	33½"	22¼"	21½"	18¼"	18"	16"	8°	9¼"	19½"	7½"	26¼"	18½"	16¼"	9¼"	96°-99°	28	—	13.2
DSC-MUGONO	1.0	11.50	33½"	22¼"	21½"	18¼"	18"	16"	8°	9¼"	19½"	7½"	26¼"	18½"	16¼"	9¼"	96°-99°	28	—	13.2

<p>How to specify — Select the Model Number from above.</p>	<p>1st Option: Select the Frame Color for Side Chairs:</p> <p>P71 Black P02 Flint P8C Salt PR6 Silver P8X Solar Black P8T Titanium</p>	<p>2nd Option: Select the Mesh Color for Side Chairs:</p> <p>C Clay D Dusk L Lustre M Mist N Navy</p>	<p>3rd Option: Select the Glides or Casters:</p> <p>0 Nylon Glides 1 Nickel Glides (\$19 extra) 2 Felt Glides (\$19 extra) 3 Multi-Surface Casters</p>	<p>4th Option: Select the Upholstery:</p> <p>See pages 13-14 for selections and color codes. See pages 6-8 for COM Guidelines.</p>
<p>D S C - M U O N O </p>				

Examples: DSC-MUCONO.P71.D.3.CU10 DSC-MUGONO.P71.D.1.CU50

Inspire is designed to support a multitude of higher education environments. In Allsteel's second collaboration with Bruce Fifield of Milan-based Design Continuum Italia, Inspire responds to the specific needs of today's dynamic learning environments. Incorporating automatic comfort technologies, students can now stay comfortable longer promoting active, engaged learning.

Inspire has achieved SCS Indoor Advantage Gold Certification and level® 2 certification. Inspire is designed and manufactured to have minimal impact on both the physical and social environment, made with no PVC components, and ranges in percent recyclable from 59% to 98%.

KEY FEATURES

TriFit™ Comfort Technologies

Inspire encourages interaction and involvement through unrestricted freedom of movement. The TriFit technology incorporates seat suspension, back recline, and seat flexure in a non-mechanical system that allows users to move freely and learn comfortably.

Breadth of Line

Today's learning environments are extending beyond the classroom. Spaces are needed that invite interaction and support collaboration. With Inspire's broad statement of line, versatile spaces are created not only in classrooms, but also in active learning environments – cafés, libraries, labs, and team project rooms – throughout campus.

Lasting Performance

Higher education environments mandate lasting performance. With Inspire's 4-sided welded steel frame construction, it creates a durable design that withstands active environments. The back recline and seat movement technologies are robust and non-mechanical to provide long-lasting, quiet use.

MODELS AND OPTIONS

Inspire models are available with arms or armless. Arm models feature two arm cap options: non-flexible for high-use environments and flexible for enhanced comfort.

Seat and back upholstery options are available on all models. Upholstery can be field-installed and is field-replaceable.

MATERIALS AND FINISHES

Polymer shells are offered in eight energizing colors and are made from recyclable material.

Trisect seating upholstery provides a high performance, sustainable fabric option to complement the eight polymer shell colors. This EIP antimony-free fabric incorporates Greenshield finish. Additional upholstery options also available.

- All upholstery foams are CFC-free.
- All COMs/COLs must be approved for upholsterability and applicable fire code compliance prior to order entry. See COM ordering instructions on pages 6-8.
- Allsteel fabrics and foam meet requirements for CAL TB117-2013. COM/COL manufacturers supply certificates of compliance for fabric-only tests such as CAL TB117-2013.
- Flammability code compliance of Allsteel textiles and seating is listed on pages 13-14. COM/COL manufacturers supply certificates of compliance for fabric-only tests such as CAL TB117-2013.

Inspire meets the requirements set forth in ANSI/BIFMA X5.1-2017. Inspire is warranted for multiple shifts and users up to 300 pounds. Inspire four-leg stack and sled base chairs ship two per carton. All other models ship one per carton. Work chairs and work stools ship fully assembled. Model numbers and pricing are per chair.

4-Leg Multi-Purpose

4-Leg Multi-Purpose chairs can stack five high.

Glides are available in nylon, nickel-plated steel, or nylon with felt options. Nylon glides are recommended for hard surfaces, commercial carpet, and damp environments. Nickel-plated steel glides are recommended for carpet. Nylon with felt glides are recommended for wood, tile, or high-sheen floor surfaces.

Multi-surface casters are also available.

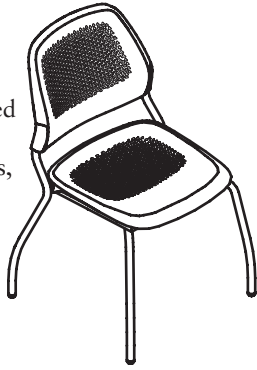

OPTIONS — 4-LEG MULTI-PURPOSE

Upholstery Option:

- N** None (Polymer seat and back)
- S** Upholstered Seat Pad
- U** Upholstered Seat and Back Pad

Glides/Casters:

- G** Glides
- C** Casters

Armrests:

- O** Fixed Arms
- A** Armless

Fire Code:

- NO** Standard Upholstery, No Fire Code

Type of Glides/Casters:

- 0** Nylon Glides
- 1** Nickel-plated Steel Glides (\$19 extra)
- 2** Nylon with Felt Glides (\$19 extra)
- 3** Multi-surface Casters

Arm Cap:

- N** No Arm
- H** Non-Flexible
- F** Flexible (\$23 extra)

Frame Finish:

- P8X** Solar Black
- P8T** Titanium
- PR6** Silver
- CBK** Charblack

Polymer Shell Color:

- | | |
|---|-------------------------------------|
| BLK Black
(formerly CB Onyx) | QR Quarry |
| BU Surf | RD Cayenne |
| BW Brownstone | RE Regatta |
| CI Citrine | RG Tangelo |
| CY Cyprus | S Flint |
| GE Sage | SN Sienna |
| GN Sprout | ST Salt |
| GY Summit | TI Titanium |
| HR Harbor | UM Umber |
| HZ Haze | WT White
(formerly Frost) |

Upholstery

See pages 13-14 for selections and pages 17-19 for color codes.

Sled Base Multi-Purpose

Sled Base Multi-Purpose chairs can stack five high.

Glides are available in polycarbonate, polycarbonate with felt or no glide options. Polycarbonate glides are recommended for hard surfaces, commercial carpet, and damp environments. Felt glides are recommended for wood, tile, or high-sheen floor surfaces.

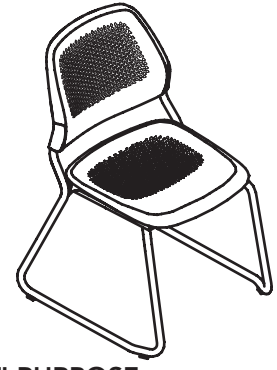

OPTIONS — SLED BASE MULTI-PURPOSE

Upholstery Option:

- N** None (Polymer seat and back)
- S** Upholstered Seat Pad
- U** Upholstered Seat and Back Pad

Armrests:

- O** Fixed Arms
- A** Armless

Fire Code:

- NO** Standard Upholstery, No Fire Code

Type of Glides:

- 0** Polycarbonate Glides
- 2** Felt Covered Polycarbonate Glides (\$19 extra)
- 4** No Glides

Arm Cap:

- N** No Arm
- H** Non-Flexible
- F** Flexible (\$23 extra)

Frame Finish:

- | | |
|-------------------------|--------------------|
| CBK Black | P8J Iris |
| P8T Titanium | P8F Krypton |
| P8B Night Bronze | P8M Regatta |
| PJE Pyrite | P096 Cove |
| PR6 Silver | P094 Dune |
| P8X Solar Black | P097 Harbor |
| P8S Atom | P093 Ochre |
| PJF Bullseye | P095 Sage |
| P8P Ember | P092 Sienna |
| P8N Ion | |

Polymer Shell Color:

- | | |
|---|-------------------------------------|
| BLK Black
(formerly CB Onyx) | QR Quarry |
| BU Surf | RD Cayenne |
| BW Brownstone | RE Regatta |
| CI Citrine | RG Tangelo |
| CY Cyprus | S Flint |
| GE Sage | SN Sienna |
| GN Sprout | ST Salt |
| GY Summit | TI Titanium |
| HR Harbor | UM Umber |
| HZ Haze | WT White
(formerly Frost) |

Upholstery

See pages 13-14 for selections and pages 17-19 for color codes.

4-Leg Tablet Arm

4-Leg Tablet Arm chairs can stack three high.

Tablets are field-installed to the chairs.

Tablet material consists of 3/4" thick 11-ply laminated Baltic Birch plywood.

Flip-and-fold tablet option provides 6 degrees of lateral rotation in the use position to accommodate a wider range of user types. It also flips up 90 degrees and rotates back 180 degrees to store when a tablet is not needed.

Glides are available in nylon, nickel-plated steel, or nylon with felt options. Nylon glides are recommended for hard surfaces, commercial carpet, and damp environments.

Nickel-plated glides are recommended for carpet. Felt glides are recommended for wood, tile, or high-shen floor surfaces.

Multi-surface casters are also available.

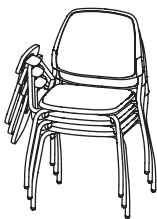
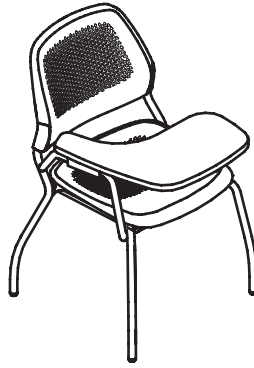

**Flip & Fold
Right Hand 4-Leg
Tablet Arm**

OPTIONS — 4-LEG TABLET ARM

Upholstery Option:

- N** None (Polymer seat and back)
- S** Upholstered Seat Pad
- U** Upholstered Seat and Back Pad

Glides/Casters:

- G** Glides
- C** Casters

Armrests:

- A** Armless

Tablet Arm:

- FR** Flip & Fold Right Hand
- FL** Flip & Fold Left Hand

Tablet Size:

- S** Standard

Fire Code:

- NO** Standard Upholstery, No Fire Code

Type of Glides/Casters:

- 0** Nylon Glides
- 1** Nickel-plated Steel Glides (\$19 extra)
- 2** Nylon with Felt Glides (\$19 extra)
- 3** Multi-surface Casters

Arm Cap:

- N** No Arm

Frame Finish:

- | | |
|-------------------------|--------------------|
| CBK Black | P8J Iris |
| P8T Titanium | P8F Krypton |
| P8B Night Bronze | P8M Regatta |
| PJE Pyrite | P096 Cove |
| PR6 Silver | P094 Dune |
| P8X Solar Black | P097 Harbor |
| P8S Atom | P093 Ochre |
| PJF Bullseye | P095 Sage |
| P8P Ember | P092 Sienna |
| P8N Ion | |

Polymer Shell Color:

- | | |
|---------------------------|--------------------|
| BLK Black | QR Quarry |
| (formerly CB Onyx) | RD Cayenne |
| BU Surf | RE Regatta |
| BW Brownstone | RG Tangelo |
| CI Citrine | S Flint |
| CY Cyprus | SN Sienna |
| GE Sage | ST Salt |
| GN Sprout | TI Titanium |
| GY Summit | UM Umber |
| HR Harbor | WT White |
| HZ Haze | (formerly Frost) |

Tablet Laminate:

- LWD** Natural Maple

Upholstery

See pages 13-14 for selections and pages 17-19 for color codes.

TABLET ARM DIMENSIONS

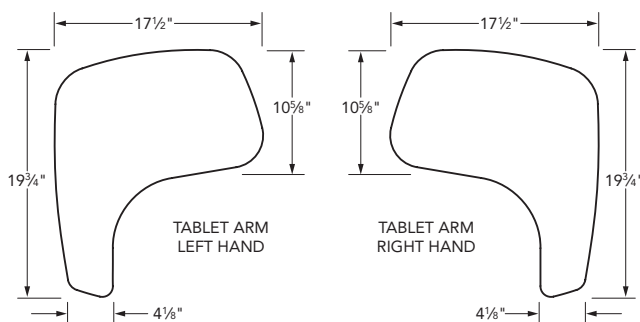

MULTI-PURPOSE WORK CHAIR

Base/Casters

Base is a black colored composite five-star structure. Dual-wheel casters feature hard tread for carpeted floors or soft tread for smooth floors.



Pneumatic Seat Height Adjustment

Regulates height of chair relative to the floor.

- Standard cylinder with 5" of travel accommodates average or tall users.
- Optional short cylinder with 3½" of travel keeps chair closer to the floor for shorter users.

OPTIONS — MULTI-PURPOSE WORK CHAIR

Upholstery Option:

- N** None (Polymer seat and back)
- S** Upholstered Seat Pad
- U** Upholstered Seat and Back Pad

Armrests:

- O** Fixed Arms
- A** Armless

Fire Code:

- NO** Standard Upholstery, No Fire Code

Pneumatic Cylinder:

- 2** Standard; allows 5" of travel
- 3** Short; non-standard 3½" of travel to meet BIFMA G1-2002

Type of Casters:

- 0** 2½" Black Dual-wheel Hard Tread for Carpet
- 1** 2½" Black Dual-wheel Soft Tread for Smooth Surfaces

Arm Cap:

- N** No Arm
- H** Non-Flexible
- F** Flexible (\$23 extra)

Frame Finish with Charblack base:

CBK Black	P8J Iris
P8T Titanium	P8F Krypton
P8B Night Bronze	P8M Regatta
PJE Pyrite	P096 Cove
PR6 Silver	P094 Dune
P8X Solar Black	P097 Harbor
P8S Atom	P093 Ochre
PJF Bullseye	P095 Sage
P8P Ember	P092 Sienna
P8N Ion	

Polymer Shell Color:

BLK Black (formerly CB Onyx)	QR Quarry
BU Surf	RD Cayenne
BW Brownstone	RE Regatta
CI Citrine	RG Tangelo
CY Cyprus	S Flint
GE Sage	SN Sienna
GN Sprout	ST Salt
GY Summit	TI Titanium
HR Harbor	UM Umber
HZ Haze	WT White (formerly Frost)

Upholstery

See pages 13-14 for selections and pages 17-19 for color codes.

MULTI-PURPOSE WORK STOOL

Base/Casters

Base is a black colored composite five-star structure. Dual-wheel casters feature hard tread for carpeted floors or soft tread for smooth floors.



Height-Adjustable Footring

Travels 8" to ensure users have comfortable support of their feet and legs. The footring has a 20" diameter.

Pneumatic Seat Height Adjustment

Regulates height of stool relative to the floor. Includes extended-range height pneumatic cylinder with 10" of vertical travel.

OPTIONS — MULTI-PURPOSE WORK STOOL

Upholstery Option:

- N** None (Polymer seat and back)
- S** Upholstered Seat Pad
- U** Upholstered Seat and Back Pad

Armrests:

- O** Fixed Arms
- A** Armless

Fire Code:

- NO** Standard Upholstery, No Fire Code

Pneumatic Cylinder:

- 4** Extended Range Cylinder; allows 10" of travel

Type of Casters:

- 0** 2½" Black Dual-wheel Hard Tread for Carpet
- 1** 2½" Black Dual-wheel Soft Tread for Smooth Surfaces
- 2** Glides (\$68 extra)

Arm Cap:

- N** No Arm
- H** Non-Flexible
- F** Flexible (\$23 extra)

Frame Finish with Charblack base:

CBK Black	P8J Iris
P8T Titanium	P8F Krypton
P8B Night Bronze	P8M Regatta
PJE Pyrite	P096 Cove
PR6 Silver	P094 Dune
P8X Solar Black	P097 Harbor
P8S Atom	P093 Ochre
PJF Bullseye	P095 Sage
P8P Ember	P092 Sienna
P8N Ion	

Polymer Shell Color:

BLK Black (formerly CB Onyx)	QR Quarry
BU Surf	RD Cayenne
BW Brownstone	RE Regatta
CI Citrine	RG Tangelo
CY Cyprus	S Flint
GE Sage	SN Sienna
GN Sprout	ST Salt
GY Summit	TI Titanium
HR Harbor	UM Umber
HZ Haze	WT White (formerly Frost)

Upholstery

See pages 13-14 for selections and pages 17-19 for color codes.

4-LEG STOOL

4-Leg stools do not stack.

Glides are available in nylon, nickel-plated steel, or nylon with felt options. Nylon glides are recommended for hard surfaces, commercial carpet, and damp environments. Nickel-plated steel glides are recommended for carpet. Nylon with felt glides are recommended for wood, tile, or high-shine floor surfaces.

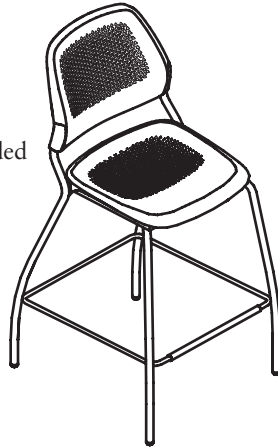

OPTIONS — 4-LEG STOOL

Upholstery Option:

- N** None (Polymer Seat and Back)
- S** Upholstered Seat Pad
- U** Upholstered Seat and Back Pad

Glides:

- G** Glides

Armrests:

- O** Fixed Arms
- A** Armless

Fire Code:

- NO** Standard Upholstery, No Fire Code

Type of Glides:

- 0** Nylon Glides
- 1** Nickel-plated Steel Glides (\$19 extra)
- 2** Nylon with Felt Glides (\$19 extra)

Arm Cap:

- N** No Arm
- H** Non-Flexible
- F** Flexible (\$23 extra)

Frame Finish:

- | | |
|-------------------------|--------------------|
| CBK Black | P8P Ember |
| P8T Titanium | P8N Ion |
| P8B Night Bronze | P8J Iris |
| PJE Pyrite | P8F Krypton |
| PR6 Silver | P8M Regatta |
| P8X Solar Black | P093 Ochre |
| P8S Atom | P092 Sienna |
| PJF Bullseye | |

Polymer Shell Color:

- | | |
|---|-------------------------------------|
| BLK Black
(formerly CB Onyx) | QR Quarry |
| BU Surf | RD Cayenne |
| BW Brownstone | RE Regatta |
| CI Citrine | RG Tangelo |
| CY Cyprus | S Flint |
| GE Sage | SN Sienna |
| GN Sprout | ST Salt |
| GY Summit | TI Titanium |
| HR Harbor | UM Umber |
| HZ Haze | WT White
(formerly Frost) |

Upholstery

See pages 13-14 for selections and pages 17-19 for color codes.

FLOOR COVERING	TYPE OF GLIDE			
	Polycarbonate/Nylon	Felt	Steel	Rubber
Carpet	Best	Not Recommended	Good	Not Recommended
Polished Concrete	Best	Good	Not Recommended	Not Recommended
Hardwood	Not Recommended	Best	Not Recommended	Good
Vinyl (Includes LVT)	Best	Better	Good	Good
VCT	Best	Good	Not Recommended	Good
Tile (Porcelain/Ceramic)	Best	Good	Not Recommended	Good
Attention	Particles can become lodged in nylon and mar floor surface.	Particles can become lodged in felt and mar floor surface.	Cleaning chemicals and water can cause rusting.	Resists moving/sliding. Could lead to chairs tipping back.

Inspire Room Typicals

These eight typicals show various arrangements featuring Inspire.

CLASSROOM

Collaborative areas feature Inspire four-leg stack chairs with casters around Merge® Power Bay™ tables. Instructor has an Inspire work stool at a variable height table.

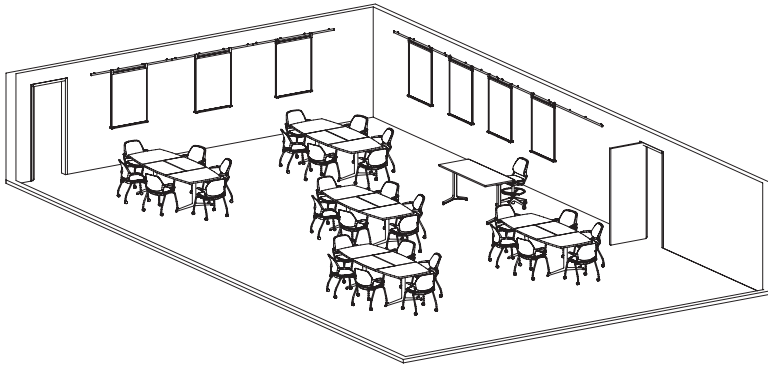

TEAM ROOM

Inspire 4-Leg Multi-Purpose with casters around a Merge Power Bay table. Stride high credenza along wall.

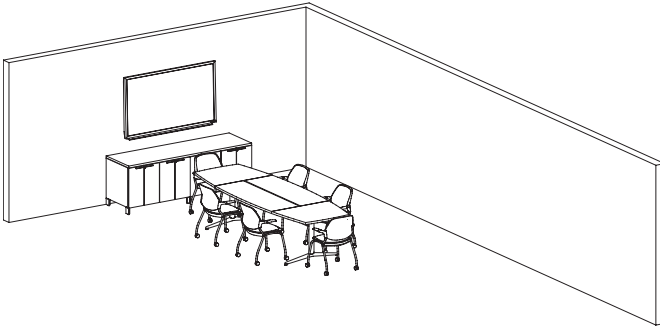

U SHAPE CLASSROOM

Inspire 4-Leg Multi-Purpose with glides around tables. Instructor has an Inspire Multi-Purpose Work Stool with a variable height table.

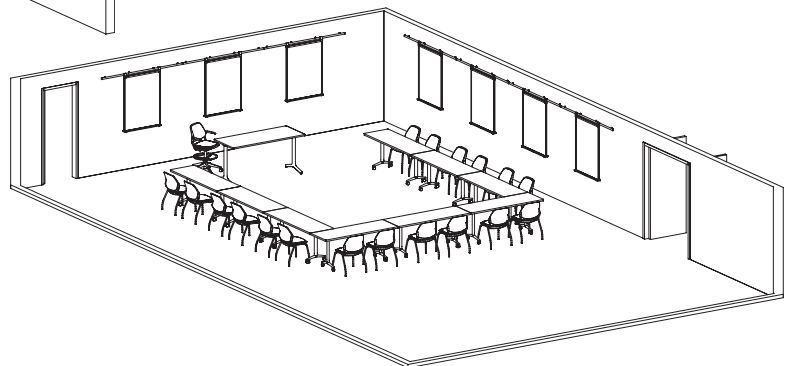

CAFÉ/ATRIUM

Inspire 4-Leg Multi-Purpose with glides around Merge tables. Inspire four-leg stools with Merge standing height tables occupy the perimeter.

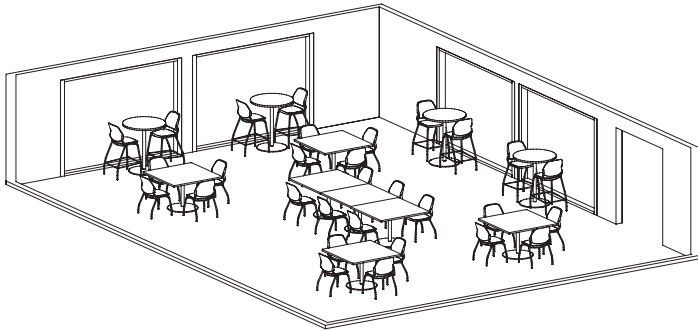

COMPUTER LAB

Inspire Multi-Purpose Work Chair with tables. Instructor has an Inspire Multi-Purpose Work Stool at a variable height table.

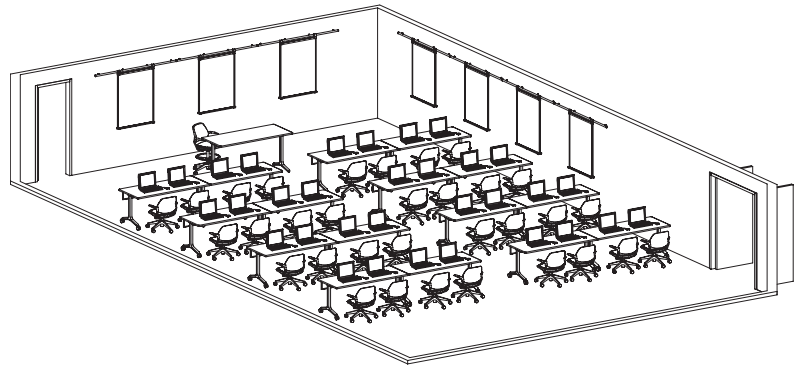

FACULTY OFFICE

Inspire 4-Leg Multi-Purpose with casters around a Merge table create a teaming area in a Stride office with an Acuity® chair.

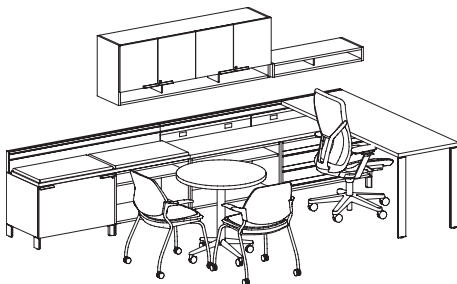





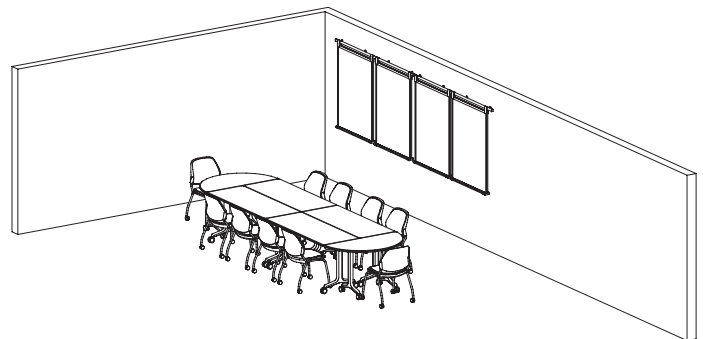

SEMINAR

Inspire 4-Leg Multi-Purpose with casters around a Merge Power Bay table.



INSPIRE

(See page 147 for COM pricing on Grades 9-22)

Backrest Style Arm Style	Seat Construction	Glide or Caster	Model Number Add options below									Leather*		
				1	2	3	4	5	6	7	8	1	2	
Polymer Back Arms 	Polymer Seat	Glide	INST-NGO	\$ 856	—	—	—	—	—	—	—	—	—	—
		Caster	INST-NCO	\$ 879	—	—	—	—	—	—	—	—	—	—
Polymer Back Armless 	Polymer Seat	Glide	INST-NGA	\$ 696	—	—	—	—	—	—	—	—	—	
		Caster	INST-NCA	\$ 743	—	—	—	—	—	—	—	—	—	
Polymer Back Arms 	Upholstered Seat Pad	Glide	INST-SGO	\$ 1016	\$ 1043	\$ 1062	\$ 1086	\$ 1110	\$ 1138	\$ 1161	\$ 1190	\$ 1268	\$ 1423	
		Caster	INST-SCO	\$ 1059	\$ 1086	\$ 1105	\$ 1129	\$ 1153	\$ 1181	\$ 1204	\$ 1233	\$ 1311	\$ 1466	
Polymer Back Armless 	Upholstered Seat Pad	Glide	INST-SGA	\$ 878	\$ 905	\$ 924	\$ 948	\$ 972	\$ 1000	\$ 1023	\$ 1052	\$ 1130	\$ 1285	
		Caster	INST-SCA	\$ 923	\$ 950	\$ 969	\$ 993	\$ 1017	\$ 1045	\$ 1068	\$ 1097	\$ 1175	\$ 1330	
Upholstered Back Pad Arms 	Upholstered Seat Pad	Glide	INST-UGO	\$ 1180	\$ 1220	\$ 1254	\$ 1302	\$ 1348	\$ 1392	\$ 1439	\$ 1485	\$ 1624	\$ 1899	
		Caster	INST-UCO	\$ 1226	\$ 1266	\$ 1300	\$ 1348	\$ 1394	\$ 1438	\$ 1485	\$ 1531	\$ 1670	\$ 1945	
Upholstered Back Pad Armless 	Upholstered Seat Pad	Glide	INST-UGA	\$ 1043	\$ 1083	\$ 1117	\$ 1165	\$ 1211	\$ 1255	\$ 1302	\$ 1348	\$ 1487	\$ 1762	
		Caster	INST-UCA	\$ 1090	\$ 1130	\$ 1164	\$ 1212	\$ 1258	\$ 1302	\$ 1349	\$ 1395	\$ 1534	\$ 1809	

Continued on next page ►

<p>How to specify — Select the Model Number from above.</p>	<p>1st Option: Select the Fire Code (if applicable): NO</p>	<p>2nd Option: Select the Glide or Caster Option: 0 Nylon Glides 1 Nickel-plated Glides (\$19 extra) 2 Felt Glides (\$19 extra) 3 Multi-surface Casters</p>	<p>3rd Option: Select the Arm Cap: N No Arm H Non-Flexible F Flexible (\$23 extra)</p>	<p>4th Option: Select the Frame Color: CBK Black P8T Titanium P8B Night Bronze PJE Pyrite PR6 Silver P8X Solar Black P8S Atom PJF Bullseye P8P Ember P8N Ion P8J Iris P8F Krypton P8M Regatta P093 Ochre P092 Sienna</p>
<p>INST- .</p>	<p> .</p>	<p> .</p>	<p> .</p>	<p> .</p>

Example: INST-NCONO.3.H.CBK.CB

Model Number	COM Package			Overall			Seat			Armrests			Backrest			One Pack Ship Weight	Two Pack Ship Weight	Cubes			
	COL Sp. Feet	Height (Range)	Width	Depth	Height	Width	Depth (Range)	Pan Angle (Range)	Height (Range)	Width Between Arms (Range)	Depth (Range)	Pivot Inwards	Pivot Outwards	Height (Range)	Width				Lumbar Height (Range)	Backrest/Seat Angle (Range)	
INST-NGO	—	—	34"	24¼"	22¼"	18¼"	18¼"	18"	4	8¼"	20¼"	11"	—	—	18¼"	18¼"	8¼"	96 - 103°	23.8	39.0	15.4
INST-NCO	—	—	34"	24¼"	22¼"	18¼"	18¼"	18"	4	8¼"	20¼"	11"	—	—	18¼"	18¼"	8¼"	96 - 103°	24.0	39.4	15.4
INST-NGA	—	—	34"	21¼"	22¼"	18¼"	18¼"	18"	4	—	—	—	—	—	18¼"	18¼"	8¼"	96 - 103°	22.0	35.4	15.4
INST-NCA	—	—	34"	21¼"	22¼"	18¼"	18¼"	18"	4	—	—	—	—	—	18¼"	18¼"	8¼"	96 - 103°	22.2	35.8	15.4
INST-SGO	.6	6	34"	24¼"	22¼"	18¼"	18¼"	18"	4	8¼"	20¼"	11"	—	—	18¼"	18¼"	8¼"	96 - 103°	25.6	42.5	15.4
INST-SCO	.6	6	34"	24¼"	22¼"	18¼"	18¼"	18"	4	8¼"	20¼"	11"	—	—	18¼"	18¼"	8¼"	96 - 103°	25.8	42.9	15.4
INST-SGA	.6	6	34"	21¼"	22¼"	18¼"	18¼"	18"	4	—	—	—	—	—	18¼"	18¼"	8¼"	96 - 103°	23.8	38.9	15.4
INST-SCA	.6	6	34"	21¼"	22¼"	18¼"	18¼"	18"	4	—	—	—	—	—	18¼"	18¼"	8¼"	96 - 103°	24.0	39.3	15.4
INST-UGO	1.0	9.5	34"	24¼"	22¼"	18¼"	18¼"	17¼"	4	8¼"	20¼"	11"	—	—	18¼"	18¼"	8¼"	96 - 103°	27.1	45.6	15.4
INST-UCO	1.0	9.5	34"	24¼"	22¼"	18¼"	18¼"	17¼"	4	8¼"	20¼"	11"	—	—	18¼"	18¼"	8¼"	96 - 103°	27.3	46.0	15.4
INST-UGA	1.0	9.5	34"	21¼"	22¼"	18¼"	18¼"	17¼"	4	—	—	—	—	—	18¼"	18¼"	8¼"	96 - 103°	25.3	42.0	15.4
INST-UCA	1.0	9.5	34"	21¼"	22¼"	18¼"	18¼"	17¼"	4	—	—	—	—	—	18¼"	18¼"	8¼"	96 - 103°	25.5	42.4	15.4





Four-leg stack chairs ship in cartons containing 2 chairs. Model numbers and prices are per chair.

◀ Continued from previous page

<p>5th Option: Select the Polymer Shell Color:</p> <p>BLK Black (formerly CB - Onyx) BU Surf BW Brownstone CI Citrine CY Cyprus GE Sage GN Sprout GY Summit HR Harbor HZ Haze</p> <p>QR Quarry RD Cayenne RE Regatta RG Tangelo S Flint SN Sienna ST Salt TI Titanium UM Umber WT White (formerly Frost)</p>	<p>6th Option: Select the Upholstery (if applicable):</p> <p>See pages 13-14 for selections. See pages 17-19 for colors and codes. See pages 6-8 for COM guidelines.</p>
---	---

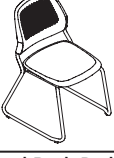

(See page 147 for COM pricing on Grades 9-22)

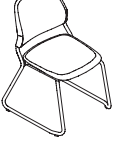
Backrest Style Arm Style	Seat Construction	Model Number Add options below									Leather*		
			1	2	3	4	5	6	7	8	1	2	
Polymer Back Arms 	Polymer Seat	INSL-NO	\$ 832	—	—	—	—	—	—	—	—	—	—
Polymer Back Armless 	Polymer Seat	INSL-NA	\$ 696	—	—	—	—	—	—	—	—	—	—
Polymer Back Arms 	Upholstered Seat Pad	INSL-SO	\$ 1011	\$ 1038	\$ 1057	\$ 1081	\$ 1105	\$ 1133	\$ 1156	\$ 1185	\$ 1263	\$ 1418	
Polymer Back Armless 	Upholstered Seat Pad	INSL-SA	\$ 878	\$ 905	\$ 924	\$ 948	\$ 972	\$ 1000	\$ 1023	\$ 1052	\$ 1130	\$ 1285	
Upholstered Back Pad Arms 	Upholstered Seat Pad	INSL-UO	\$ 1177	\$ 1217	\$ 1251	\$ 1299	\$ 1345	\$ 1389	\$ 1436	\$ 1482	\$ 1621	\$ 1896	
Upholstered Back Pad Armless 	Upholstered Seat Pad	INSL-UA	\$ 1043	\$ 1083	\$ 1117	\$ 1165	\$ 1211	\$ 1255	\$ 1302	\$ 1348	\$ 1487	\$ 1762	

Continued on next page ►

<p>How to specify — Select the Model Number from above.</p> <p>INSL-□□□□</p>	<p>1st Option: Select the Fire Code (if applicable): NO</p>	<p>2nd Option: Select the Glide Option: 0 Polycarbonate Glides 2 Felt Covered Polycarbonate Glides (\$19 extra) 4 No Glides</p>	<p>3rd Option: Select the Arm Cap: N No Arm H Non-Flexible F Flexible (\$23 extra)</p>	<p>4th Option: Select the Frame Color: CBK Black P8T Titanium P8B Night Bronze PJE Pyrite PR6 Silver P8X Solar Black P8S Atom PJF Bullseye P8P Ember P8N Ion P8J Iris P8F Krypton P8M Regatta P093 Ochre P092 Sienna</p>
---	--	--	---	---

Example: INSL-SANO.2.N.PR6.BU.TSC96

INSPIRE

Model Number	Overall							Seat			Armrests				Backrest			One Pack Ship Weight	Two Pack Ship Weight	Cubes	
	COM Yardage	COL Sp. Feet	Height (Range)	Width	Depth	Height	Width	Depth (Range)	Pan Angle (Range)	Height (Range)	Width Between Arms (Range)	Depth (Range)	Pivot Inwards	Pivot Outwards	Height (Range)	Width	Lumbar Height (Range)				Backrest/Seat Angle (Range)
INSL-NO	—	—	34"	24¼"	22¼"	18¼"	18½"	18"	4°	8½"	20½"	11"	—	—	18½"	18½"	8½"	96 - 103°	25.2	41.8	15.4
INSL-NA	—	—	34"	21¼"	22¼"	18¼"	18½"	18"	4°	—	—	—	—	—	18½"	18½"	8½"	96 - 103°	23.4	38.2	15.4
INSL-SO	.6	6	34"	24¼"	22¼"	18¼"	18½"	18"	4°	8½"	20½"	11"	—	—	18½"	18½"	8½"	96 - 103°	27.0	45.3	15.4
INSL-SA	.6	6	34"	21¼"	22¼"	18¼"	18½"	18"	4°	—	—	—	—	—	18½"	18½"	8½"	96 - 103°	25.2	41.7	15.4
INSL-UO	1.0	9.5	34"	24¼"	22¼"	18¼"	18½"	17¼"	4°	8½"	20½"	11"	—	—	18½"	18½"	8½"	96 - 103°	28.5	48.4	15.4
INSL-UA	1.0	9.5	34"	21¼"	22¼"	18¼"	18½"	17¼"	4°	—	—	—	—	—	18½"	18½"	8½"	96 - 103°	26.7	44.8	15.4



Sled base stack chairs ship in cartons containing 2 chairs. Model numbers and prices are per chair.

◀ Continued from previous page

<p>5th Option: Select the Polymer Shell Color:</p> <table border="0"> <tr> <td>BLK Black (formerly CB - Onyx)</td> <td>QR Quarry</td> </tr> <tr> <td>BU Surf</td> <td>RD Cayenne</td> </tr> <tr> <td>BW Brownstone</td> <td>RE Regatta</td> </tr> <tr> <td>CI Citrine</td> <td>RG Tangelo</td> </tr> <tr> <td>CY Cyprus</td> <td>S Flint</td> </tr> <tr> <td>GE Sage</td> <td>SN Sienna</td> </tr> <tr> <td>GN Sprout</td> <td>ST Salt</td> </tr> <tr> <td>GY Summit</td> <td>TI Titanium</td> </tr> <tr> <td>HR Harbor</td> <td>UM Umber</td> </tr> <tr> <td>HZ Haze</td> <td>WT White (formerly Frost)</td> </tr> </table>	BLK Black (formerly CB - Onyx)	QR Quarry	BU Surf	RD Cayenne	BW Brownstone	RE Regatta	CI Citrine	RG Tangelo	CY Cyprus	S Flint	GE Sage	SN Sienna	GN Sprout	ST Salt	GY Summit	TI Titanium	HR Harbor	UM Umber	HZ Haze	WT White (formerly Frost)	<p>6th Option: Select the Upholstery (if applicable):</p> <p>See pages 13-14 for selections. See pages 17-19 for colors and codes. See pages 6-8 for COM guidelines.</p>
BLK Black (formerly CB - Onyx)	QR Quarry																				
BU Surf	RD Cayenne																				
BW Brownstone	RE Regatta																				
CI Citrine	RG Tangelo																				
CY Cyprus	S Flint																				
GE Sage	SN Sienna																				
GN Sprout	ST Salt																				
GY Summit	TI Titanium																				
HR Harbor	UM Umber																				
HZ Haze	WT White (formerly Frost)																				



(See page 147 for COM pricing on Grades 9-22)

Backrest Style	Seat Construction	Tablet Style	Glide or Caster	Model Number <i>Add options below</i>											Leather*	
					1	2	3	4	5	6	7	8	1	2		
FLIP & FOLD TABLET — 4 LEG																
Polymer Back 	Polymer Seat	Flip & Fold	Glide	INSTT-NGAFRS	\$ 1145	—	—	—	—	—	—	—	—	—		
		Right	Caster	INSTT-NCAFRS	\$ 1191	—	—	—	—	—	—	—	—	—		
		Flip & Fold	Glide	INSTT-NGAFLS	\$ 1145	—	—	—	—	—	—	—	—	—		
		Left	Caster	INSTT-NCAFLS	\$ 1191	—	—	—	—	—	—	—	—	—		
Polymer Back 	Upholstered Seat Pad	Flip & Fold	Glide	INSTT-SGAFRS	\$ 1312	\$ 1339	\$ 1358	\$ 1382	\$ 1407	\$ 1436	\$ 1459	\$ 1489	\$ 1567	\$ 1727		
		Right	Caster	INSTT-SCAFRS	\$ 1356	\$ 1383	\$ 1402	\$ 1426	\$ 1451	\$ 1480	\$ 1503	\$ 1533	\$ 1611	\$ 1771		
		Flip & Fold	Glide	INSTT-SGAFLS	\$ 1312	\$ 1339	\$ 1358	\$ 1382	\$ 1407	\$ 1436	\$ 1459	\$ 1489	\$ 1567	\$ 1727		
		Left	Caster	INSTT-SCAFLS	\$ 1356	\$ 1383	\$ 1402	\$ 1426	\$ 1451	\$ 1480	\$ 1503	\$ 1533	\$ 1611	\$ 1771		
Upholstered Back Pad 	Upholstered Seat Pad	Flip & Fold	Glide	INSTT-UGAFRS	\$ 1496	\$ 1536	\$ 1570	\$ 1620	\$ 1666	\$ 1712	\$ 1758	\$ 1807	\$ 1948	\$ 2229		
		Right	Caster	INSTT-UCAFRS	\$ 1542	\$ 1582	\$ 1616	\$ 1666	\$ 1712	\$ 1758	\$ 1804	\$ 1853	\$ 1994	\$ 2275		
		Flip & Fold	Glide	INSTT-UGAFLS	\$ 1496	\$ 1536	\$ 1570	\$ 1620	\$ 1666	\$ 1712	\$ 1758	\$ 1807	\$ 1948	\$ 2229		
		Left	Caster	INSTT-UCAFLS	\$ 1542	\$ 1582	\$ 1616	\$ 1666	\$ 1712	\$ 1758	\$ 1804	\$ 1853	\$ 1994	\$ 2275		

INSPIRE

Continued on next page ►

<p>How to specify — Select the Model Number from above.</p> <p>I N S T - [] [] [] [] []</p>	<p>1st Option: Select the Fire Code (if applicable):</p> <p>NO</p>	<p>2nd Option: Select the Glide or Caster Option:</p> <p>0 Nylon Glides 1 Nickel-plated Glides for Four-Leg only (\$19 extra) 2 Felt Glides (\$19 extra) 3 Multi-surface Casters for Four-Leg only 4 No Glides for Sled Base only</p>	<p>3rd Option: Select the Arm Cap:</p> <p>N No Arm</p>	<p>4th Option: Select the Frame Color:</p> <table border="0"> <tr> <td>CBK Black</td> <td>P8P Ember</td> </tr> <tr> <td>P8T Titanium</td> <td>P8N Ion</td> </tr> <tr> <td>P8B Night Bronze</td> <td>P8J Iris</td> </tr> <tr> <td>PJE Pyrite</td> <td>P8F Krypton</td> </tr> <tr> <td>PR6 Silver</td> <td>P8M Regatta</td> </tr> <tr> <td>P8X Solar Black</td> <td>P093 Ochre</td> </tr> <tr> <td>P8S Atom</td> <td>P092 Sienna</td> </tr> <tr> <td>PJF Bullseye</td> <td></td> </tr> </table> <p>[] [] [] [] [] .</p>	CBK Black	P8P Ember	P8T Titanium	P8N Ion	P8B Night Bronze	P8J Iris	PJE Pyrite	P8F Krypton	PR6 Silver	P8M Regatta	P8X Solar Black	P093 Ochre	P8S Atom	P092 Sienna	PJF Bullseye	
CBK Black	P8P Ember																			
P8T Titanium	P8N Ion																			
P8B Night Bronze	P8J Iris																			
PJE Pyrite	P8F Krypton																			
PR6 Silver	P8M Regatta																			
P8X Solar Black	P093 Ochre																			
P8S Atom	P092 Sienna																			
PJF Bullseye																				

Example: INSTT-NGAFRSNO.2.N.CBK.RD.LWD







Model Number	COM Yandage			Overall			Seat			Armrests			Backrest			One Back Ship Weight	Cubes		
	COL Sp. Feet	Height (Range)	Width	Depth	Height	Width	Depth (Range)	Pan Angle (Range)	Height (Range)	Width Between Arms (Range)	Depth (Range)	Pivot Inwards	Pivot Outwards	Height (Range)	Width			Lumbar Height (Range)	Backrest Seat Angle (Range)
4 LEG																			
INSTT-NGAFRS	—	—	34"	25½"		18¼"	18¼"	18"	4°	—	—	—	—	18¼"	18¼"	8¼"	96-103°	32.8	15.4
INSTT-NCAFRS	—	—	34"	25½"	22¼"	18¼"	18¼"	18"	4°	—	—	—	—	18¼"	18¼"	8¼"	96-103°	33.0	15.4
INSTT-NGAFLS	—	—	34"	25½"	22¼"	18¼"	18¼"	18"	4°	—	—	—	—	18¼"	18¼"	8¼"	96-103°	32.8	15.4
INSTT-NCAFLS	—	—	34"	25½"	22¼"	18¼"	18¼"	18"	4°	—	—	—	—	18¼"	18¼"	8¼"	96-103°	33.0	15.4
				22¼"															
INSTT-SGAFRS	.6	6	34"	25½"		18¼"	18¼"	18"	4°	—	—	—	—	18¼"	18¼"	8¼"	96-103°	34.6	15.4
INSTT-SCAFRS	.6	6	34"	25½"	22¼"	18¼"	18¼"	18"	4°	—	—	—	—	18¼"	18¼"	8¼"	96-103°	34.8	15.4
INSTT-SGAFLS	.6	6	34"	25½"	22¼"	18¼"	18¼"	18"	4°	—	—	—	—	18¼"	18¼"	8¼"	96-103°	34.6	15.4
INSTT-SCAFLS	.6	6	34"	25½"	22¼"	18¼"	18¼"	18"	4°	—	—	—	—	18¼"	18¼"	8¼"	96-103°	34.8	15.4
				22¼"															
INSTT-UGAFRS	1.0	9.5	34"	25½"		18¼"	18¼"	17¼"	4°	—	—	—	—	18¼"	18¼"	8¼"	96-103°	36.1	15.4
INSTT-UCAFRS	1.0	9.5	34"	25½"	22¼"	18¼"	18¼"	17¼"	4°	—	—	—	—	18¼"	18¼"	8¼"	96-103°	36.3	15.4
INSTT-UGAFLS	1.0	9.5	34"	25½"	22¼"	18¼"	18¼"	17¼"	4°	—	—	—	—	18¼"	18¼"	8¼"	96-103°	36.1	15.4
INSTT-UCAFLS	1.0	9.5	34"	25½"	22¼"	18¼"	18¼"	17¼"	4°	—	—	—	—	18¼"	18¼"	8¼"	96-103°	36.3	15.4
				22¼"															

INSPIRE

◀ Continued from previous page

<p>5th Option: Select the Polymer Shell Color:</p> <p>BLK Black (formerly CB – Onyx) BU Surf BW Brownstone CI Citrine CY Cyprus GE Sage GN Sprout GY Summit HR Harbor HZ Haze</p> <p>QR Quarry RD Cayenne RE Regatta RG Tangelo S Flint SN Sienna ST Salt TI Titanium UM Umber WT White (formerly Frost)</p>	<p>6th Option: Select the Tablet Laminate Color:</p> <p>LWD Natural Maple</p>	<p>7th Option: Select the Upholstery (if applicable):</p> <p>See pages 13-14 for selections. See pages 17-19 for colors and codes. See pages 6-8 for COM guidelines.</p>
---	---	---

(See page 147 for COM pricing on Grades 9-22)

Backrest Style Arm Style	Seat Construction	Model Number Add options below									Leather*		
			1	2	3	4	5	6	7	8	1	2	
Polymer Back Arms 	Polymer Seat	INTK-NO	\$ 1119	—	—	—	—	—	—	—	—	—	—
Polymer Back Armless 	Polymer Seat	INTK-NA	\$ 983	—	—	—	—	—	—	—	—	—	—
Polymer Back Arms 	Upholstered Seat Pad	INTK-SO	\$ 1299	\$ 1326	\$ 1345	\$ 1369	\$ 1393	\$ 1421	\$ 1444	\$ 1473	\$ 1551	\$ 1706	
Polymer Back Armless 	Upholstered Seat Pad	INTK-SA	\$ 1164	\$ 1191	\$ 1210	\$ 1234	\$ 1258	\$ 1286	\$ 1309	\$ 1338	\$ 1416	\$ 1571	
Upholstered Back Pad Arms 	Upholstered Seat Pad	INTK-UO	\$ 1464	\$ 1504	\$ 1538	\$ 1586	\$ 1632	\$ 1676	\$ 1723	\$ 1769	\$ 1908	\$ 2183	
Upholstered Back Pad Armless 	Upholstered Seat Pad	INTK-UA	\$ 1329	\$ 1369	\$ 1403	\$ 1451	\$ 1497	\$ 1541	\$ 1588	\$ 1634	\$ 1773	\$ 2048	

Continued on next page ►

<p>How to specify — Select the Model Number from above.</p> <p>INTK-□□</p>	<p>1st Option: Select the Fire Code (if applicable): NO</p> <p>□□.</p>	<p>2nd Option: Select the Cylinder Option: 2 Standard, allows 5" of travel 3 Short, allows 3½" of travel</p> <p>□.</p>	<p>3rd Option: Select the Caster Option: 0 2½" Black Dual-wheel Hard Tread for carpet 1 2½" Black Dual-wheel Soft Tread for smooth surfaces (add \$34)</p> <p>□.</p>	<p>4th Option: Select the Arm Cap: N No Arm H Non-Flexible F Flexible (\$23 extra)</p> <p>□.</p>
---	---	---	---	---

Example: INTK-UANO.2.0.N.PR6.CB.TSC94







Model Number	Overall			Seat				Armrests				Backrest			Ship Weight	Ship Weight Per Carton	Cubes				
	COM Package	COL Sp. Feet	Height (Range)	Width	Depth	Height	Width	Depth (Range)	Pan Angle (Range)	Height (Range)	Width Between Arms (Range)	Depth (Range)	Pivot Inwards	Pivot Outwards				Height (Range)	Width	Lumbar Height (Range)	Backrest/Seat Angle (Range)
INTK-NO	—	—	34-39"	24½"	25"	17¼-22¼"	18½"	18"	4°	8½"	20½"	11"	—	—	18½"	18½"	8½"	96-103°	28.9	—	15.4
INTK-NA	—	—	34-39"	24½"	25"	17¼-22¼"	18½"	18"	4°	—	—	—	—	—	18½"	18½"	8½"	96-103°	27.1	—	15.4
INTK-SO	.6	6	34-39"	24½"	25"	17¼-22¼"	18½"	18"	4°	8½"	20½"	11"	—	—	18½"	18½"	8½"	96-103°	30.7	—	15.4
INTK-SA	.6	6	34-39"	24½"	25"	17¼-22¼"	18½"	18"	4°	—	—	—	—	—	18½"	18½"	8½"	96-103°	28.9	—	15.4
INTK-UO	1.0	9.5	34-39"	24½"	25"	17¼-22¼"	18½"	17½"	4°	8½"	20½"	11"	—	—	18½"	18½"	8½"	96-103°	32.2	—	15.4
INTK-UA	1.0	9.5	34-39"	24½"	25"	17¼-22¼"	18½"	17½"	4°	—	—	—	—	—	18½"	18½"	8½"	96-103°	30.4	—	15.4

INSPIRE

◀ Continued from previous page

<p><i>5th Option:</i></p> <p>Select the Frame Color with Charblack base:</p> <table border="0"> <tr> <td>CBK Black</td> <td>P8P Ember</td> </tr> <tr> <td>P8T Titanium</td> <td>P8N Ion</td> </tr> <tr> <td>P8B Night Bronze</td> <td>P8J Iris</td> </tr> <tr> <td>PJE Pyrite</td> <td>P8F Krypton</td> </tr> <tr> <td>PR6 Silver</td> <td>P8M Regatta</td> </tr> <tr> <td>P8X Solar Black</td> <td>P093 Ochre</td> </tr> <tr> <td>P8S Atom</td> <td>P092 Sienna</td> </tr> <tr> <td>PJF Bullseye</td> <td></td> </tr> </table>	CBK Black	P8P Ember	P8T Titanium	P8N Ion	P8B Night Bronze	P8J Iris	PJE Pyrite	P8F Krypton	PR6 Silver	P8M Regatta	P8X Solar Black	P093 Ochre	P8S Atom	P092 Sienna	PJF Bullseye		<p><i>6th Option:</i></p> <p>Select the Polymer Shell Color:</p> <table border="0"> <tr> <td>BLK Black (formerly CB - Onyx)</td> <td>QR Quarry</td> </tr> <tr> <td>BU Surf</td> <td>RD Cayenne</td> </tr> <tr> <td>BW Brownstone</td> <td>RE Regatta</td> </tr> <tr> <td>CI Citrine</td> <td>RG Tangelo</td> </tr> <tr> <td>CY Cyprus</td> <td>S Flint</td> </tr> <tr> <td>GE Sage</td> <td>SN Sienna</td> </tr> <tr> <td>GN Sprout</td> <td>ST Salt</td> </tr> <tr> <td>GY Summit</td> <td>TI Titanium</td> </tr> <tr> <td>HR Harbor</td> <td>UM Umber</td> </tr> <tr> <td>HZ Haze</td> <td>WT White (formerly Frost)</td> </tr> </table>	BLK Black (formerly CB - Onyx)	QR Quarry	BU Surf	RD Cayenne	BW Brownstone	RE Regatta	CI Citrine	RG Tangelo	CY Cyprus	S Flint	GE Sage	SN Sienna	GN Sprout	ST Salt	GY Summit	TI Titanium	HR Harbor	UM Umber	HZ Haze	WT White (formerly Frost)	<p><i>7th Option:</i></p> <p>Select the Upholstery (if applicable):</p> <p>See pages 13-14 for selections.</p> <p>See pages 17-19 for colors and codes.</p> <p>See pages 6-8 for COM guidelines.</p>
CBK Black	P8P Ember																																					
P8T Titanium	P8N Ion																																					
P8B Night Bronze	P8J Iris																																					
PJE Pyrite	P8F Krypton																																					
PR6 Silver	P8M Regatta																																					
P8X Solar Black	P093 Ochre																																					
P8S Atom	P092 Sienna																																					
PJF Bullseye																																						
BLK Black (formerly CB - Onyx)	QR Quarry																																					
BU Surf	RD Cayenne																																					
BW Brownstone	RE Regatta																																					
CI Citrine	RG Tangelo																																					
CY Cyprus	S Flint																																					
GE Sage	SN Sienna																																					
GN Sprout	ST Salt																																					
GY Summit	TI Titanium																																					
HR Harbor	UM Umber																																					
HZ Haze	WT White (formerly Frost)																																					

(See page 147 for COM pricing on Grades 9-22)

Backrest Style Arm Style	Seat Construction	Model Number Add options below									Leather*		
			1	2	3	4	5	6	7	8	1	2	
Polymer Back Arms 	Polymer Seat	INWS-NO	\$ 1384	—	—	—	—	—	—	—	—	—	—
Polymer Back Armless 	Polymer Seat	INWS-NA	\$ 1250	—	—	—	—	—	—	—	—	—	—
Polymer Back Arms 	Upholstered Seat Pad	INWS-SO	\$ 1564	\$ 1591	\$ 1610	\$ 1634	\$ 1658	\$ 1686	\$ 1709	\$ 1738	\$ 1816	\$ 1971	
Polymer Back Armless 	Upholstered Seat Pad	INWS-SA	\$ 1430	\$ 1457	\$ 1476	\$ 1500	\$ 1524	\$ 1552	\$ 1575	\$ 1604	\$ 1682	\$ 1837	
Upholstered Back Pad Arms 	Upholstered Seat Pad	INWS-UO	\$ 1730	\$ 1770	\$ 1804	\$ 1852	\$ 1898	\$ 1942	\$ 1989	\$ 2035	\$ 2174	\$ 2449	
Upholstered Back Pad Armless 	Upholstered Seat Pad	INWS-UA	\$ 1596	\$ 1636	\$ 1670	\$ 1718	\$ 1764	\$ 1808	\$ 1855	\$ 1901	\$ 2040	\$ 2315	

Continued on next page ►

<p>How to specify — Select the Model Number from above.</p>	<p>1st Option: Select the Fire Code (if applicable): NO</p>	<p>2nd Option: Select the Cylinder Option: 4 Extended Range Work Stool Cylinder, allows 10" of travel</p>	<p>3rd Option: Select the Caster Option: 0 2½" Black Dual-wheel Hard Tread for carpet 1 2½" Black Dual-wheel Soft Tread for smooth surfaces (add \$34) 2 Glides (add \$68)</p>	<p>4th Option: Select the Arm Cap: N No Arm H Non-Flexible F Flexible (\$23 extra)</p>
INWS-□□□	□□.	4.	□.	□.

Example: INWS-NANO.4.0.N.CBK.WT

INSPIRE







Model Number	COM Yandage			Overall			Seat				Armrests				Backrest				Ship Weight	Ship Weight Per Carton	Cubes
	COL Sp. Feet	Height (Range)	Width	Depth	Height (Range)	Width	Depth (Range)	Pan Angle (Range)	Height (Range)	Width Between Arms (Range)	Depth (Range)	Pivot Inwards	Pivot Outwards	Height (Range)	Width	Lumbar Height (Range)	Backrest/Seat Angle (Range)				
INWS-NO	—	—	37"-47"	24½"	25"	21½-31"	18"	18"	4°	8"	20"	11"	—	—	18"	18"	8"	96-103°	35.1	—	22.9
INWS-NA	—	—	37"-47"	24½"	25"	21½-31"	18"	18"	4°	—	—	—	—	—	18"	18"	8"	96-103°	33.3	—	22.9
INWS-SO	.6	6	37"-47"	24½"	25"	21½-31"	18"	18"	4°	8"	20"	11"	—	—	18"	18"	8"	96-103°	36.9	—	22.9
INWS-SA	.6	6	37"-47"	24½"	25"	21½-31"	18"	18"	4°	—	—	—	—	—	18"	18"	8"	96-103°	35.1	—	22.9
INWS-UO	1.0	9.5	37"-47"	24½"	25"	21½-31"	18"	17"	4°	8"	20"	11"	—	—	18"	18"	8"	96-103°	38.4	—	22.9
INWS-UA	1.0	9.5	37"-47"	24½"	25"	21½-31"	18"	17"	4°	—	—	—	—	—	18"	18"	8"	96-103°	36.6	—	22.9

INSPIRE

◀ Continued from previous page

<p><i>5th Option:</i></p> <p>Select the Frame Color with Charblack base:</p> <table border="0"> <tr> <td>CBK Black</td> <td>P8P Ember</td> </tr> <tr> <td>P8T Titanium</td> <td>P8N Ion</td> </tr> <tr> <td>P8B Night Bronze</td> <td>P8J Iris</td> </tr> <tr> <td>PJE Pyrite</td> <td>P8F Krypton</td> </tr> <tr> <td>PR6 Silver</td> <td>P8M Regatta</td> </tr> <tr> <td>P8X Solar Black</td> <td>P093 Ochre</td> </tr> <tr> <td>P8S Atom</td> <td>P092 Sienna</td> </tr> <tr> <td>PJF Bullseye</td> <td></td> </tr> </table>	CBK Black	P8P Ember	P8T Titanium	P8N Ion	P8B Night Bronze	P8J Iris	PJE Pyrite	P8F Krypton	PR6 Silver	P8M Regatta	P8X Solar Black	P093 Ochre	P8S Atom	P092 Sienna	PJF Bullseye		<p><i>6th Option:</i></p> <p>Select the Polymer Shell Color:</p> <table border="0"> <tr> <td>BLK Black (formerly CB – Onyx)</td> <td>QR Quarry</td> </tr> <tr> <td>BU Surf</td> <td>RD Cayenne</td> </tr> <tr> <td>BW Brownstone</td> <td>RE Regatta</td> </tr> <tr> <td>CI Citrine</td> <td>RG Tangelo</td> </tr> <tr> <td>CY Cyprus</td> <td>S Flint</td> </tr> <tr> <td>GE Sage</td> <td>SN Sienna</td> </tr> <tr> <td>GN Sprout</td> <td>ST Salt</td> </tr> <tr> <td>GY Summit</td> <td>TI Titanium</td> </tr> <tr> <td>HR Harbor</td> <td>UM Umber</td> </tr> <tr> <td>HZ Haze</td> <td>WT White (formerly Frost)</td> </tr> </table>	BLK Black (formerly CB – Onyx)	QR Quarry	BU Surf	RD Cayenne	BW Brownstone	RE Regatta	CI Citrine	RG Tangelo	CY Cyprus	S Flint	GE Sage	SN Sienna	GN Sprout	ST Salt	GY Summit	TI Titanium	HR Harbor	UM Umber	HZ Haze	WT White (formerly Frost)	<p><i>7th Option:</i></p> <p>Select the Upholstery (if applicable):</p> <p>See pages 13-14 for selections.</p> <p>See pages 17-19 for colors and codes.</p> <p>See pages 6-8 for COM guidelines.</p>
CBK Black	P8P Ember																																					
P8T Titanium	P8N Ion																																					
P8B Night Bronze	P8J Iris																																					
PJE Pyrite	P8F Krypton																																					
PR6 Silver	P8M Regatta																																					
P8X Solar Black	P093 Ochre																																					
P8S Atom	P092 Sienna																																					
PJF Bullseye																																						
BLK Black (formerly CB – Onyx)	QR Quarry																																					
BU Surf	RD Cayenne																																					
BW Brownstone	RE Regatta																																					
CI Citrine	RG Tangelo																																					
CY Cyprus	S Flint																																					
GE Sage	SN Sienna																																					
GN Sprout	ST Salt																																					
GY Summit	TI Titanium																																					
HR Harbor	UM Umber																																					
HZ Haze	WT White (formerly Frost)																																					

(See page 147 for COM pricing on Grades 9-22)

Backrest Style Arm Style	Seat Construction	Model Number Add options below									Leather*		
			1	2	3	4	5	6	7	8	1	2	
Polymer Back Arms 	Polymer Seat	INFS-NGO	\$ 1379	—	—	—	—	—	—	—	—	—	—
Polymer Back Armless 	Polymer Seat	INFS-NGA	\$ 1250	—	—	—	—	—	—	—	—	—	—
Polymer Back Arms 	Upholstered Seat Pad	INFS-SGO	\$ 1558	\$ 1585	\$ 1604	\$ 1628	\$ 1652	\$ 1680	\$ 1703	\$ 1732	\$ 1810	\$ 1965	
Polymer Back Armless 	Upholstered Seat Pad	INFS-SGA	\$ 1430	\$ 1457	\$ 1476	\$ 1500	\$ 1524	\$ 1552	\$ 1575	\$ 1604	\$ 1682	\$ 1837	
Upholstered Back Pad Arms 	Upholstered Seat Pad	INFS-UGO	\$ 1724	\$ 1764	\$ 1798	\$ 1846	\$ 1892	\$ 1936	\$ 1983	\$ 2029	\$ 2168	\$ 2443	
Upholstered Back Pad Armless 	Upholstered Seat Pad	INFS-UGA	\$ 1596	\$ 1636	\$ 1670	\$ 1718	\$ 1764	\$ 1808	\$ 1855	\$ 1901	\$ 2040	\$ 2315	

Continued on next page ►

<p>How to specify — Select the Model Number from above.</p>	<p>1st Option: Select the Fire Code (if applicable): NO</p>	<p>2nd Option: Select the Glide Option: 0 Nylon Glides 1 Nickel-plated Glides (\$19 extra) 2 Felt Glides (\$19 extra)</p>	<p>3rd Option: Select the Arm Cap: N No Arm H Non-Flexible F Flexible (\$23 extra)</p>	<p>4th Option: Select the Frame Color: CBK Black P8T Titanium P8B Night Bronze PJE Pyrite PR6 Silver P8X Solar Black P8S Atom PJF Bullseye P8P Ember P8N Ion P8J Iris P8F Krypton P8M Regatta P093 Ochre P092 Sienna</p>
<p>INFS- </p>	<p> .</p>	<p> .</p>	<p> .</p>	<p> .</p>

Example: INSF-UGANO.0.F.PR6.GY.TSC89

INSPIRE

Model Number	Overall				Seat			Armrests				Backrest			Ship Weight	Ship Weight Per Carton	Cubes		
	COM Landge	COL. Sq. Feet	Height (Range)	Width	Depth	Height	Width	Depth (Range)	Pan Angle (Range)	Height (Range)	Width Between Arms (Range)	Depth (Range)	Height (Range)	Width				Lumbar Height (Range)	Backrest/Seat Angle (Range)
INFS-NGO	—	—	45½"	24¼"	24¼"	30"	18½"	18"	4°	8¼"	20½"	11"	18½"	18½"	8¼"	96-103°	29.6	—	22.9
INFS-NGA	—	—	45½"	22"	24¼"	30"	18½"	18"	4°	—	—	—	18½"	18½"	8¼"	96-103°	27.8	—	22.9
INFS-SGO	.6	6	45½"	24¼"	24¼"	30½"	18½"	18"	4°	8¼"	20½"	11"	18½"	18½"	8¼"	96-103°	31.4	—	22.9
INFS-SGA	.6	6	45½"	22"	24¼"	30½"	18½"	18"	4°	—	—	—	18½"	18½"	8¼"	96-103°	29.6	—	22.9
INFS-UGO	1.0	9.5	45½"	24¼"	24¼"	30½"	18½"	17¾"	4°	8¼"	20½"	11"	18½"	18½"	8¼"	96-103°	32.9	—	22.9
INFS-UGA	1.0	9.5	45½"	22"	24¼"	30½"	18½"	17¾"	4°	—	—	—	18½"	18½"	8¼"	96-103°	31.1	—	22.9



◀ Continued from previous page

<p><i>5th Option:</i></p> <p>Select the Polymer Shell Color:</p> <table style="width: 100%;"> <tr> <td>BLK Black (formerly</td> <td>QR Quarry</td> </tr> <tr> <td>CB - Onyx)</td> <td>RD Cayenne</td> </tr> <tr> <td>BU Surf</td> <td>RE Regatta</td> </tr> <tr> <td>BW Brownstone</td> <td>RG Tangelo</td> </tr> <tr> <td>CI Citrine</td> <td>S Flint</td> </tr> <tr> <td>CY Cyprus</td> <td>SN Sienna</td> </tr> <tr> <td>GE Sage</td> <td>ST Salt</td> </tr> <tr> <td>GN Sprout</td> <td>TI Titanium</td> </tr> <tr> <td>GY Summit</td> <td>UM Umber</td> </tr> <tr> <td>HR Harbor</td> <td>WT White (formerly Frost)</td> </tr> <tr> <td>HZ Haze</td> <td></td> </tr> </table>	BLK Black (formerly	QR Quarry	CB - Onyx)	RD Cayenne	BU Surf	RE Regatta	BW Brownstone	RG Tangelo	CI Citrine	S Flint	CY Cyprus	SN Sienna	GE Sage	ST Salt	GN Sprout	TI Titanium	GY Summit	UM Umber	HR Harbor	WT White (formerly Frost)	HZ Haze		<p><i>6th Option:</i></p> <p>Select the Upholstery (if applicable):</p> <p>See pages 13-14 for selections.</p> <p>See pages 17-19 for colors and codes.</p> <p>See pages 6-8 for COM guidelines.</p>
BLK Black (formerly	QR Quarry																						
CB - Onyx)	RD Cayenne																						
BU Surf	RE Regatta																						
BW Brownstone	RG Tangelo																						
CI Citrine	S Flint																						
CY Cyprus	SN Sienna																						
GE Sage	ST Salt																						
GN Sprout	TI Titanium																						
GY Summit	UM Umber																						
HR Harbor	WT White (formerly Frost)																						
HZ Haze																							

The Lyric family of seating provides a multitude of choices. Make a serious statement with subdued colors or create a fun and playful vibe with a bold mix of mesh and upholstery. Lyric's comfort and intuitive functionality, paired with its simple but striking lines, make it perfect from the workstation to the training room to the conference room.



Lyric Work
CWW-MHHNO

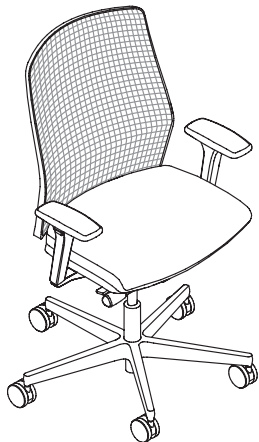

Lyric Large & Tall
CLL-MLHNO

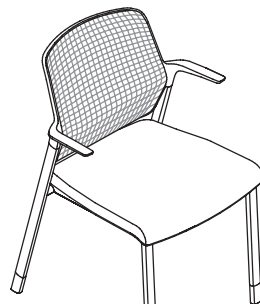

Lyric Side
CSC-MUGONO

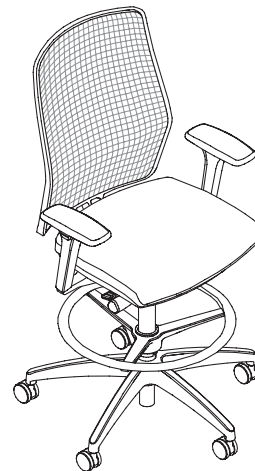

Lyric Stool
CSS-MHHNO

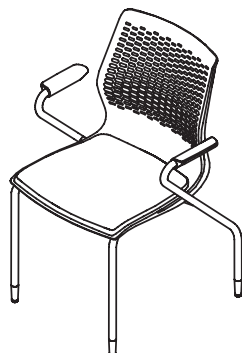

Lyric Multi-Purpose
Chair
CMPNU-PPGONO

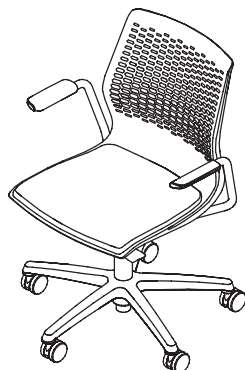

Lyric Multi-Purpose
Work Chair
CMPWU-PPCONO

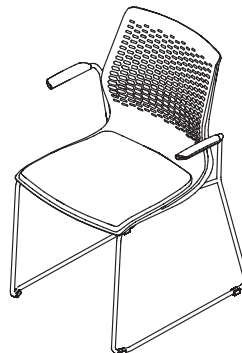

Lyric Wire Stacker
CWSU-PPGONO

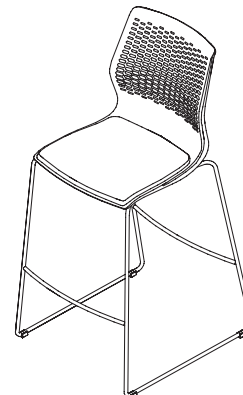

Lyric Wire Stool
CWSS30U-PPGANO

LYRIC

DESIGN FEATURES

Choose the options specific to your needs.

Basic synchro control adjustment

Manual crank tension with knob and an upright lock.

Enhanced synchro-tilt control

Manual crank tension adjustment with easily reached lever and three locking positions for the back.

Weight activated control

Automatic tension control with an upright lock and tilt limiter.

Mesh Backs

Mesh back chairs are available in six mesh colors.

Optional adjustable lumbar support

Lyric provides automatic lumbar support. To accommodate personal preference, an optional external lumbar support can be added at any time with 4" range of adjustment.

4D fully adjustable arms

Lyric's 4D arms are fully adjustable in height, width, depth, and can pivot to provide optimal support. Pivot the front of the arm pads inward to move in closer to your desk and offer support while working.

2D adjustable arms

Provides height and width adjustments for optimal support of elbows and shoulders while keyboarding or conferencing while providing ease of entry/exit.

Fixed arms

Provide basic support for users engaging in a variety of tasks throughout the day. Fixed arms limit adjustability but provide consistent aesthetics in conference room settings.

Pneumatic seat height adjustment

Regulates height of work chair relative to the floor. Standard 5" of travel accommodates average to tall users. Stools offer 10" of travel.

Seat depth adjustment

Allows seat cushion to manually adjust front to back.

Base and casters

Work chair and stool bases are a five-star design. Dual-wheel casters are available in hard tread for carpet, or multi-surface for any floor surface.

Materials

- All COMs/COLs must be approved for upholsterability or applicable fire code compliance prior to order entry. See pages 6-8 for COM ordering instructions. All steel fabrics meet requirements for CTB117. COM/COL manufacturers supply certificates of compliance for fabric only tests such as CTB117.
- Lyric meets the requirements set forth in ANSI/BIFMA X5.1-2011 and BIFMA G1-2013. Lyric is warranted for multiple shifts and users up to 300 lbs.

Height-Adjustable Footring

Travels 8" to ensure users have comfortable support of their feet and legs. The footring has a 20" diameter.

OPTIONS - WORK/CONFERENCE OR STOOL

Chair Types:

CWW	Weight Activated Work Chair
CSW	Synchro-Tilt Work Chair
CBW	Basic Synchro Work Chair
CSS	Synchro-Tilt Stool

Back:

MH	Mesh High-Back
MM	Mesh Mid-Back

Arms:

W	4D Fully Adjustable
H	2D Adjustable
F	Fixed
A	Armless

Frame Color:

BLK	Black
T	Titanium (add \$46)
P096	Cove
P094	Dune
P097	Harbor
P095	Sage

Base Color:

BLK	Black
T	Titanium
PAL	Polished Aluminum (add \$164)

Lumbar:

N	No Lumbar
L	Lumbar (add \$34)

Lumbar Color:

BLK	Black
T	Titanium

Cylinder:

2	Standard
3	Short
4	Extended (stool only)

Casters:

H	Black Hard Tread
B	Black Multi-Surface (add \$68)
T	Titanium Multi-Surface (add \$68)
PAL	Polished Aluminum (add \$147)

Mesh Back Material:

FWM55	Black
FWM75	Charcoal
FWM80	Titanium
FWM85	Salt
FWM65	Brownstone
FWM60	Regatta









Seat Upholstery:

See pages 13-14 for selections, colors, and codes.

Headrest:

N	No Headrest
HR	Headrest (add \$135)

(See page 148 for COM pricing on Grades 9-22)

Armrest	Control	Back	Model Number Add options below									Leather	
				1	2	3	4	5	6	7	8	1	2
 	Weight	Mesh High-Back	CWW-MHW	\$1482	\$1497	\$1507	\$1530	\$1554	\$1576	\$1601	\$1625	\$1647	\$2264
	Activated	Mesh Mid-Back	CWW-MMW	\$1446	\$1461	\$1471	\$1494	\$1518	\$1540	\$1565	\$1589	\$1611	\$2228
	Synchro	Mesh High-Back	CSW-MHW	\$1358	\$1373	\$1383	\$1406	\$1430	\$1452	\$1477	\$1501	\$1523	\$2140
		Mesh Mid-Back	CSW-MMW	\$1322	\$1337	\$1347	\$1370	\$1394	\$1416	\$1441	\$1465	\$1487	\$2104
	Basic	Mesh High-Back	CBW-MHW	\$1296	\$1311	\$1321	\$1344	\$1368	\$1390	\$1415	\$1439	\$1461	\$2078
	Synchro	Mesh Mid-Back	CBW-MMW	\$1262	\$1277	\$1287	\$1310	\$1334	\$1356	\$1381	\$1405	\$1427	\$2044
 	Weight	Mesh High-Back	CWW-MHH	\$1406	\$1421	\$1431	\$1454	\$1478	\$1500	\$1525	\$1549	\$1571	\$2188
	Activated	Mesh Mid-Back	CWW-MMH	\$1370	\$1385	\$1395	\$1418	\$1442	\$1464	\$1489	\$1513	\$1535	\$2152
	Synchro	Mesh High-Back	CSW-MHH	\$1283	\$1298	\$1308	\$1331	\$1355	\$1377	\$1402	\$1426	\$1448	\$2065
		Mesh Mid-Back	CSW-MMH	\$1247	\$1262	\$1272	\$1295	\$1319	\$1341	\$1366	\$1390	\$1412	\$2029
	Basic	Mesh High-Back	CBW-MHH	\$1222	\$1237	\$1247	\$1270	\$1294	\$1316	\$1341	\$1365	\$1387	\$2004
	Synchro	Mesh Mid-Back	CBW-MMH	\$1187	\$1202	\$1212	\$1235	\$1259	\$1281	\$1306	\$1330	\$1352	\$1969
 	Weight	Mesh High-Back	CWW-MHF	\$1417	\$1432	\$1442	\$1465	\$1489	\$1511	\$1536	\$1560	\$1582	\$2199
	Activated	Mesh Mid-Back	CWW-MMF	\$1382	\$1397	\$1407	\$1430	\$1454	\$1476	\$1501	\$1525	\$1547	\$2164
	Synchro	Mesh High-Back	CSW-MHF	\$1294	\$1309	\$1319	\$1342	\$1366	\$1388	\$1413	\$1437	\$1459	\$2076
		Mesh Mid-Back	CSW-MMF	\$1259	\$1274	\$1284	\$1307	\$1331	\$1353	\$1378	\$1402	\$1424	\$2041
	Basic	Mesh High-Back	CBW-MHF	\$1232	\$1247	\$1257	\$1280	\$1304	\$1326	\$1351	\$1375	\$1397	\$2014
	Synchro	Mesh Mid-Back	CBW-MMF	\$1196	\$1211	\$1221	\$1244	\$1268	\$1290	\$1315	\$1339	\$1361	\$1978
 	Weight	Mesh High-Back	CWW-MHA	\$1284	\$1299	\$1309	\$1332	\$1356	\$1378	\$1403	\$1427	\$1449	\$2066
	Activated	Mesh Mid-Back	CWW-MMA	\$1248	\$1263	\$1273	\$1296	\$1320	\$1342	\$1367	\$1391	\$1413	\$2030
	Synchro	Mesh High-Back	CSW-MHA	\$1162	\$1177	\$1187	\$1210	\$1234	\$1256	\$1281	\$1305	\$1327	\$1944
		Mesh Mid-Back	CSW-MMA	\$1126	\$1141	\$1151	\$1174	\$1198	\$1220	\$1245	\$1269	\$1291	\$1908
	Basic	Mesh High-Back	CBW-MHA	\$1101	\$1116	\$1126	\$1149	\$1173	\$1195	\$1220	\$1244	\$1266	\$1883
	Synchro	Mesh Mid-Back	CBW-MMA	\$1064	\$1079	\$1089	\$1112	\$1136	\$1158	\$1183	\$1207	\$1229	\$1846
Lumbar Kit			LLUK	\$ 61									
Headrest Kit			C-HDRK	\$ 256									

LYRIC

Continued on next page ►

<p>How to specify — Select the Model Number from above. Add NO to the end of the model</p>	<p>1st Option: Select the Frame Color: BLK Black T Titanium (add \$46)</p>	<p>2nd Option: Select the Base Color: BLK Black T Titanium PAL Polished Aluminum (\$164 extra)</p>	<p>3rd Option: Select the Lumbar: N No Lumbar L Lumbar (\$34 extra)</p>	<p>4th Option: Select the Lumbar Color (if applicable): BLK Black T Titanium</p>
_____.	_____.	_____.	_____.	_____.

Examples: CWW-MHWNO.T.T.LT.2.T.FWM55.AI26 LLUK.BLK

Model Number	COM Yandage			Overall				Seat			Armrests				Backrest						
	COL Sq. Feet	Height (Range)		Width	Depth	Height Std (Range) Short Range (15-18 1/2")	Width	Depth	Pan Angle (Range)	Armrest Height	Width Between Arms	Depth (Range)	Pivot Inwards	Pivot Outwards	Height	Width	Lumbar Height*	Backrest Seat Angle (Range)	Ship Weight	Ship Weight Per Carton	CuYds
CWW-MHW	0.80	20	38" - 43"	26"	26"	16" - 21"	19"	15" - 18 1/2"	6.4°	7" - 11 1/2"	13" - 20"	11" - 14"	30°	30°	24"	19"	9"	94° - 116°	37	48	11.3
CWW-MMW	0.80	20	35" - 40"	26"	26"	16" - 21"	19"	15" - 18 1/2"	6.4°	7" - 11 1/2"	13" - 20"	11" - 14"	30°	30°	21"	19"	9"	94° - 116°	37	48	11.3
CSW-MHW	0.80	20	38" - 43"	26"	26"	16" - 21"	19"	16" - 18 1/2"	11.7°	7" - 11 1/2"	13" - 20"	11" - 14"	30°	30°	24"	19"	9"	94° - 110°	38	48	11.3
CSW-MMW	0.80	20	35" - 40"	26"	26"	16" - 21"	19"	16" - 18 1/2"	11.7°	7" - 11 1/2"	13" - 20"	11" - 14"	30°	30°	21"	19"	9"	94° - 110°	38	48	11.3
CBW-MHW	0.80	20	38" - 43"	26"	26"	16" - 21"	19"	15" - 17 1/2"	9.7°	7" - 11 1/2"	13" - 20"	11" - 14"	30°	30°	24"	19"	9"	95° - 104°	37	45	11.3
CBW-MMW	0.80	20	35" - 40"	26"	26"	16" - 21"	19"	15" - 17 1/2"	9.7°	7" - 11 1/2"	13" - 20"	11" - 14"	30°	30°	21"	19"	9"	95° - 104°	37	45	11.3
														Arm to Floor							
CWW-MHH	0.80	20	38" - 43"	26"	26"	16" - 21"	19"	15" - 18 1/2"	6.4°	7" - 11 1/2"	17" - 20 1/2"	14" - 14"	24" - 32"	24"	19"	9"	94° - 116°	37	48	11.3	
CWW-MMH	0.80	20	35" - 40"	26"	26"	16" - 21"	19"	15" - 18 1/2"	6.4°	7" - 11 1/2"	17" - 20 1/2"	14" - 14"	24" - 32"	21"	19"	9"	94° - 116°	37	48	11.3	
CSW-MHH	0.80	20	38" - 43"	26"	26"	16" - 21"	19"	16" - 18 1/2"	11.7°	7" - 11 1/2"	17" - 20 1/2"	14" - 14"	23" - 32 1/2"	24"	19"	9"	94° - 110°	38	48	11.3	
CSW-MMH	0.80	20	35" - 40"	26"	26"	16" - 21"	19"	16" - 18 1/2"	11.7°	7" - 11 1/2"	17" - 20 1/2"	14" - 14"	23" - 32 1/2"	21"	19"	9"	94° - 110°	38	48	11.3	
CBW-MHH	0.80	20	38" - 43"	26"	26"	16" - 21"	19"	15" - 17 1/2"	9.7°	7" - 11 1/2"	17" - 20 1/2"	14" - 14"	23" - 32 1/2"	24"	19"	9"	95° - 104°	37	45	11.3	
CBW-MMH	0.80	20	35" - 40"	26"	26"	16" - 21"	19"	15" - 17 1/2"	9.7°	7" - 11 1/2"	17" - 20 1/2"	14" - 14"	23" - 32 1/2"	21"	19"	9"	95° - 104°	37	45	11.3	
CWW-MHF	0.80	20	38" - 43"	26"	26"	16" - 21"	19"	15" - 18 1/2"	6.4°	9"	20"	14"	25" - 30 1/2"	24"	19"	9"	94° - 116°	37	48	11.3	
CWW-MMF	0.80	20	35" - 40"	26"	26"	16" - 21"	19"	15" - 18 1/2"	6.4°	9"	20"	14"	25" - 30 1/2"	21"	19"	9"	94° - 116°	37	48	11.3	
CSW-MHF	0.80	20	38" - 43"	26"	26"	16" - 21"	19"	16" - 18 1/2"	11.7°	9"	20"	14"	25" - 30 1/2"	24"	19"	9"	94° - 110°	38	48	11.3	
CSW-MMF	0.80	20	35" - 40"	26"	26"	16" - 21"	19"	16" - 18 1/2"	11.7°	9"	20"	14"	25" - 30 1/2"	21"	19"	9"	94° - 110°	38	48	11.3	
CBW-MHF	0.80	20	38" - 43"	26"	26"	16" - 21"	19"	15" - 17 1/2"	9.7°	9"	20"	14"	25" - 30 1/2"	24"	19"	9"	95° - 104°	37	45	11.3	
CBW-MMF	0.80	20	35" - 40"	26"	26"	16" - 21"	19"	15" - 17 1/2"	9.7°	9"	20"	14"	25" - 30 1/2"	21"	19"	9"	95° - 104°	37	45	11.3	
CWW-MHA	0.80	20	38" - 43"	26"	26"	16" - 21"	19"	15" - 18 1/2"	6.4°						24"	19"	9"	94° - 116°	37	48	11.3
CWW-MMA	0.80	20	35" - 40"	26"	26"	16" - 21"	19"	15" - 18 1/2"	6.4°						21"	19"	9"	94° - 116°	37	48	11.3
CSW-MHA	0.80	20	38" - 43"	26"	26"	16" - 21"	19"	16" - 18 1/2"	11.7°						24"	19"	9"	94° - 110°	38	48	11.3
CSW-MMA	0.80	20	35" - 40"	26"	26"	16" - 21"	19"	16" - 18 1/2"	11.7°						21"	19"	9"	94° - 110°	38	48	11.3
CBW-MHA	0.80	20	38" - 43"	26"	26"	16" - 21"	19"	15" - 17 1/2"	9.7°						24"	19"	9"	95° - 104°	37	45	11.3
CBW-MMA	0.80	20	35" - 40"	26"	26"	16" - 21"	19"	15" - 17 1/2"	9.7°						21"	19"	9"	95° - 104°	37	45	11.3
C-HDRK			10" - 12 1/4"	11 1/4"	3 1/4"																

Note: Dimensions are in accordance with BIFMA G1-2013 guidelines — see illustration of guidelines on page 45.





*Optional external lumbar support can be added at any time with a 4" range of adjustment.

◀ Continued from previous page

<p>5th Option: Select the Cylinder:</p> <p>2 Standard 3 Short</p>	<p>6th Option: Select the Casters:</p> <p>H Black Hard Tread B Black Multi-Surface (\$68 extra) T Titanium Multi-Surface (\$68 extra) PAL Polished Aluminum Multi-Surface (\$147 extra)</p>	<p>7th Option: Select the Mesh:</p> <p>FWM55 Black FWM75 Charcoal FWM80 Titanium FWM85 Salt FWM65 Brownstone FWM60 Regatta</p>	<p>8th Option: Select the Upholstery:</p> <p>See pages 13-14 for selection, colors, and codes.</p>	<p>9th Option: Select the Headrest (if applicable):</p> <p>N No Headrest HR Headrest (+\$135 extra)</p>
--	--	---	---	--

LYRIC

(See page 148 for COM pricing on Grades 9-22)

Armrest	Control	Back	Model Number									Leather	
				1	2	3	4	5	6	7	8	1	2
	Synchro	Mesh High-Back	CSS-MHW	\$ 1805	\$ 1816	\$ 1825	\$ 1843	\$ 1861	\$ 1880	\$ 1898	\$ 1917	\$ 1935	\$ 2419
		Mesh Mid-Back	CSS-MMW	\$ 1777	\$ 1788	\$ 1797	\$ 1815	\$ 1833	\$ 1852	\$ 1870	\$ 1889	\$ 1907	\$ 2391
	Synchro	Mesh High-Back	CSS-MHH	\$ 1745	\$ 1756	\$ 1765	\$ 1783	\$ 1801	\$ 1820	\$ 1838	\$ 1857	\$ 1875	\$ 2359
		Mesh Mid-Back	CSS-MMH	\$ 1718	\$ 1729	\$ 1738	\$ 1756	\$ 1774	\$ 1793	\$ 1811	\$ 1830	\$ 1848	\$ 2332
	Synchro	Mesh High-Back	CSS-MHF	\$ 1755	\$ 1766	\$ 1775	\$ 1793	\$ 1811	\$ 1830	\$ 1848	\$ 1867	\$ 1885	\$ 2369
		Mesh Mid-Back	CSS-MMF	\$ 1727	\$ 1738	\$ 1747	\$ 1765	\$ 1783	\$ 1802	\$ 1820	\$ 1839	\$ 1857	\$ 2341
	Synchro	Mesh High-Back	CSS-MHA	\$ 1650	\$ 1661	\$ 1670	\$ 1688	\$ 1706	\$ 1725	\$ 1743	\$ 1762	\$ 1780	\$ 2264
		Mesh Mid-Back	CSS-MMA	\$ 1621	\$ 1632	\$ 1641	\$ 1659	\$ 1677	\$ 1696	\$ 1714	\$ 1733	\$ 1751	\$ 2235
			C-HDRK	\$ 256									

LYRIC

Continued on next page ►

<p>How to specify — Select the Model Number from above. Add NO to the end of the model</p>	<p>1st Option: Select the Frame Color: BLK Black (<i>Black Mesh</i>) T Titanium (<i>Titanium Mesh</i>) (add \$46)</p>	<p>2nd Option: Select the Base Color: BLK Black T Titanium PAL Polished Aluminum (\$164 extra)</p>	<p>3rd Option: Select the Lumbar: N No Lumbar L Lumbar (\$34 extra)</p>	<p>4th Option: Select the Lumbar Color (if applicable): BLK Black T Titanium</p>	<p>5th Option: Select the Cylinder: 4 Extended range work stool cylinder allows 10" of travel</p>
C S S - . .					4 .

Examples: CSS-MHHNO.T.T.LT.4.T.FWM55.AI26

Model Number	Overall			Seat		Armrests				Backrest											
	COM Yardage	COL Sq. Feet	Height (Range)	Width	Depth	Height & d (Range)	Seat Range (15°-18½°)	Width	Depth	Pan Angle (Range)	Armrest Height	Width Between Arms	Depth (Range)	Pivot Inwards	Pivot Outwards	Height	Width	Lumbar Height*	Backrest/Seat Angle (Range)	Ship Weight	Ship Weight Per Carton
CSS-MHW	0.80	20	46" - 56"	26"	26"	22¼"-32¼"	19½"	16¼"-18½"	11.7"	7½"-11½"	17¼"-20½"	14¼"-14¼"	30¼"-44¼"	24"	19"	9"	94½°-110°	43	53	11.3	
CSS-MMW	0.80	20	43" - 53"	26"	26"	22¼"-32¼"	19½"	16¼"-18½"	11.7"	7½"-11½"	17¼"-20½"	14¼"-14¼"	30¼"-44¼"	21"	19"	9"	94½°-110°	43	53	11.3	
CSS-MHH	0.80	20	46" - 56"	26"	26"	22¼"-32¼"	19½"	16¼"-18½"	11.7"	7½"-11½"	17¼"-20½"	14¼"-14¼"	30¼"-44¼"	24"	19"	9"	94½°-110°	43	53	11.3	
CSS-MMH	0.80	20	43" - 53"	26"	26"	22¼"-32¼"	19½"	16¼"-18½"	11.7"	7½"-11½"	17¼"-20½"	14¼"-14¼"	30¼"-44¼"	21"	19"	9"	94½°-110°	43	53	11.3	
CSS-MHF	0.80	20	46" - 56"	26"	26"	22¼"-32¼"	19½"	16¼"-18½"	11.7"	9"	20½"	14"	30¼"-44¼"	24"	19"	9"	94½°-110°	43	53	11.3	
CSS-MMF	0.80	20	43" - 53"	26"	26"	22¼"-32¼"	19½"	16¼"-18½"	11.7"	9"	20½"	14"	30¼"-44¼"	21"	19"	9"	94½°-110°	43	53	11.3	
CSS-MHA	0.80	20	46" - 56"	26"	26"	22¼"-32¼"	19½"	16¼"-18½"	11.7"					24"	19"	9"	94½°-110°	43	53	11.3	
CSS-MMA	0.80	20	43" - 53"	26"	26"	22¼"-32¼"	19½"	16¼"-18½"	11.7"					21"	19"	9"	94½°-110°	43	53	11.3	
C-HDRK			10" - 12¼"	11¼"	3¼"																

Note: Dimensions are in accordance with BIFMA G1-2013 guidelines — see illustration of guidelines on page 45.

*Optional external lumbar support can be added at any time with a 4" range of adjustment.

◀ Continued from previous page

<p>6th Option: Select the Casters:</p> <p>H Black Hard Tread B Black Multi-Surface (\$68 extra) T Titanium Multi-Surface (\$68 extra) PAL Polished Aluminum Multi-Surface (\$147 extra)</p>	<p>7th Option: Select the Mesh (if applicable):</p> <p>FWM55 Black FWM75 Charcoal FWM80 Titanium FWM85 Salt FWM65 Brownstone FWM60 Regatta</p>	<p>8th Option: Select the Seat Upholstery:</p> <p>See pages 13-14 for selection, colors, and codes.</p>	<p>9th Option: Select the Headrest (if applicable):</p> <p>N No Headrest HR Headrest (+\$135 extra)</p>
--	---	--	--



DESIGN FEATURES

An economical solution, suited for larger and taller people who perform a variety of tasks. Lyric Large & Tall is warranted for multiple shifts and users up to 400 lbs.

Enhanced synchro-tilt control

Manual crank tension adjustment with easily reached lever and three locking positions for the back.

Mesh Backs

Mesh back Large & Tall chairs are available in Black mesh.

2D adjustable arms

Provides height and width adjustments for optimal support of elbows and shoulders while keyboarding or conferencing while providing ease of entry/exit.

Fixed arms

Provide basic support for users engaging in a variety of tasks throughout the day. Fixed arms limit adjustability but provide consistent aesthetics in conference room settings.

Pneumatic seat height adjustment

Regulates height of work chair relative to the floor. Standard 5" of travel accommodates average to tall users.

Base and casters

Bases are a five-star design. Dual-wheel casters in multi-surface for any floor surface.

Materials

- All COMs/COLs must be approved for upholsterability or applicable fire code compliance prior to order entry. See pages 6-8 for COM ordering instructions.
- Allsteel fabrics meet requirements for CTB117. COM/COL manufacturers supply certificates of compliance for fabric only tests such as CTB117.
- Lyric LT meets the requirements set forth in ANSI/BIFMA X5.1-2011 and BIFMA G1-2013. Lyric LT is warranted for multiple shifts and users up to 400 lbs.

OPTIONS — LARGE & TALL

Chair Types:

CLL Large & Tall

Back:

ML Mesh Large & Tall

Arms:

H 2D Adjustable

F Fixed

A Armless

Frame Color:

BLK Black

T Titanium (add \$46)

Base Color:

BLK Black

T Titanium

Lumbar:

N No Lumbar

L Lumbar (add \$34)

Lumbar Color:

BLK Black

T Titanium

Cylinder:

2 Standard

Casters:

B Black Multi-Surface

Mesh Back Material:

FWM55 Black



Seat Upholstery:

See pages 13-14 for selections, colors, and codes.



CLL-MLHNO — Large & Tall

(See page 148 for COM pricing on Grades 9-22)

Armrest	Control	Back	Model Number									Leather	
				1	2	3	4	5	6	7	8	1	2
2D Arms 	Synchro	Mesh High-Back	CLL-MLH	\$ 1914	\$ 1929	\$ 1939	\$ 1962	\$ 1986	\$ 2008	\$ 2033	\$ 2057	\$ 2079	\$ 2696
Fixed Arms 	Synchro	Mesh High-Back	CLL-MLF	\$ 1925	\$ 1940	\$ 1950	\$ 1973	\$ 1997	\$ 2019	\$ 2044	\$ 2068	\$ 2090	\$ 2707
Armless 	Synchro	Mesh High-Back	CLL-MLA	\$ 1793	\$ 1808	\$ 1818	\$ 1841	\$ 1865	\$ 1887	\$ 1912	\$ 1936	\$ 1958	\$ 2575
L & T Lumbar Kit			LLUK-LT	\$ 67									

Model Number	Overall			Seat			Armrests			Backrest			Cubes					
	COM Yards	COL Sq. Feet	Height (Range)	Width	Depth	Height Std (Range)	Width	Depth	Pan Angle (Range)	Armrest Height	Width Between Arms	Depth (Range)		Height	Width	Lumbar Height	Backrest/Seat Angle (Range)	Ship Weight
CLL-MLH			41" - 46"	28"	28"	19"-24"	22"	16 1/4" - 18 1/2"	15.8°	7 1/2" - 11 1/2"	19 1/4" - 22 1/4"	14 1/2" - 15 1/2"	25 1/2"	21 1/2"	11"	93°-105°	42	7.3
CLL-MLF			41" - 46"	28"	28"	19"-24"	22"	16 1/4" - 18 1/2"	15.8°	7 1/2" - 11 1/2"	19 1/4" - 22 1/4"	14 1/2" - 15 1/2"	25 1/2"	21 1/2"	11"	93°-105°	42	7.3
CLL-MLA			41" - 46"	28"	28"	19"-24"	22"	16 1/4" - 18 1/2"	15.8°	—	—	—	25 1/2"	21 1/2"	11"	93°-105°	41	7.3

Note: Dimensions are in accordance with BIFMA G1-2013 guidelines — see illustration of guidelines on page 45.

<p>How to specify — Select the Model Number from above. Add NO to the end of the model</p> <p>_____ .</p>	<p>1st Option: Select the Frame Color: BLK Black (Black Mesh) T Titanium (Black Mesh) (add \$46)</p> <p>_____ .</p>	<p>2nd Option: Select the Base Color: BLK Black T Titanium</p> <p>_____ .</p>	<p>3rd Option: Select the Lumbar: N No Lumbar L Lumbar (\$34 extra)</p> <p>_____ .</p>	<p>4th Option: Select the Lumbar Color (if applicable): BLK Black T Titanium</p> <p>_____ .</p>
<p>5th Option: Select the Cylinder: 2 Standard</p> <p>2 .</p>	<p>6th Option: Select the Casters: B Black Multi-Surface</p> <p>B .</p>	<p>7th Option: Select the Mesh (if applicable): FWM55 Black</p> <p>FWM55 .</p>	<p>8th Option: Select the Seat Upholstery: See pages 13-14 for selection, colors, and codes.</p> <p>_____ .</p>	

Example: LLUK-LT.BLK

LYRIC

Wherever they are, invite visitors to sit in style with options like an upholstered or mesh back, adding comfort and style to any location.

KEY FEATURES

The waterfall seat front reduces pressure points and the intuitive back design offers built-in lumbar support. Lyric side chairs can be stacked up to four high.

MODELS AND OPTIONS

Lyric side chair models with back types in mesh or upholstered mesh, and in two frame colors. Side chairs feature arm models with casters or glides.

Glides are available in nylon, nickel-plated, or felt options. Nylon glides are recommended for hard surfaces, commercial carpet, and damp environments. Nickel-plated glides are recommended for carpet. Felt glides are recommended for wood, tile, or high-shen floor surfaces. The versatile multi-surface casters are designed for use on hard or soft surfaces.

Chairs ship up to three per carton to minimize waste.

MATERIALS

- All COMs/COLs must be approved for upholsterability or applicable fire code compliance prior to order entry. See pages 6-8 for COM ordering instructions.
- Allsteel fabrics meet requirements for CTB117. COM/COL manufacturers supply certificates of compliance for fabric only tests such as CTB117.
- Lyric side chairs are warranted for users up to 300 lbs.

OPTIONS — SIDE CHAIR

Chair Types:

CSC Four Leg Side Chair

Back/Seat Material:

MU Mesh Back / Upholstered Seat

UU Upholstered Mesh Back / Upholstered Seat

Casters/Glides:

C Casters

G Glides

Arms:

O Fixed Arm

Fire code:

NO No Fire Code

Type of Caster or Glide:

0 Nylon Glides for hard surfaces and commercial carpet

1 Nickel Glides for carpet (\$19 extra)

2 Felt Glides for wood, tile, or high sheen surfaces (\$19 extra)

3 Multi-Surface Caster

Frame Color (Predetermines Mesh Color on Upholstered Models):

P71 Black (Black Mesh on Upholstered Models)

PR6 Silver (Titanium Mesh on Upholstered Models)

P8X Solar Black (Black Mesh on Upholstered Models)

P8T Titanium (Titanium Mesh on Upholstered Models)

Mesh Back Material for Upholstered Models, Centurion Fabric Code (see page 17):

Mesh Back Material

FWM55 Black

FWM75 Charcoal

FWM80 Titanium

FWM85 Salt

FWM65 Brownstone

FWM60 Regatta

Seat Upholstery:

See pages 13-14 for selections, colors, and codes.

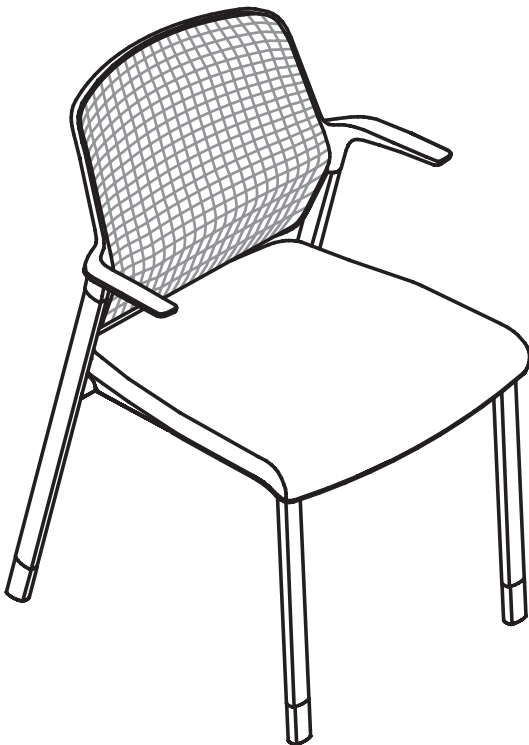



CSC-MUGO — Mesh Back with Glides

Seating — Side

Lyric™

GSA SIN 33721

(See page 148 for COM pricing on Grades 9-22)

Description	Back	Model Number	1	2	3	4	5	6	7	8	Leather	
											1	2
GLIDES Arms 	Mesh Back	CSC-MUGONO	\$ 801	\$ 832	\$ 860	\$ 904	\$ 948	\$ 993	\$ 1037	\$ 1082	\$ 1125	\$ 1937
	Upholstered Mesh Back	CSC-UUGONO	\$ 922	\$ 953	\$ 981	\$ 1025	\$ 1069	\$ 1114	\$ 1158	\$ 1203	\$ 1246	\$ 2058
CASTERS Arms 	Mesh Back	CSC-MUCONO	\$ 846	\$ 877	\$ 905	\$ 949	\$ 993	\$ 1038	\$ 1082	\$ 1127	\$ 1170	\$ 1982
	Upholstered Mesh Back	CSC-UUCONO	\$ 968	\$ 999	\$ 1027	\$ 1071	\$ 1115	\$ 1160	\$ 1204	\$ 1249	\$ 1292	\$ 2104

NOTE: Lyric side chairs ship up to three per carton to minimize waste. Model numbers and prices are per chair.

Model Number	Overall			Seat				Armrests			Backrest							
	COM Yardage (seat only)	Height	Width	Depth	Height	Width	Depth	Pan Angle	Height	Width Between Arms	Arm Pad Width	Height	Width	Lumbar Height	Backrest/Seat Angle (Range)	Ship Weight Per Chair	Ship Weight Per Carton	Cubes
CSC-MUGONO	1.0	32½"	22¼"	23¾"	18½"	18½"	16½"	6.5°	9"	19½"	1¾"	17½"	16¼"	10"	96.3°	28	—	20
CSC-UUGONO	1.0	32½"	22¼"	23¾"	18½"	18½"	16½"	6.5°	9"	19½"	1¾"	17½"	16¼"	10"	96.3°	28	—	20
CSC-MUCONO	1.0	32½"	22¼"	23¾"	18½"	18½"	16½"	6.5°	9"	19½"	1¾"	17½"	16¼"	10"	96.3°	28	—	20
CSC-UUCONO	1.0	32½"	22¼"	23¾"	18½"	18½"	16½"	6.5°	9"	19½"	1¾"	17½"	16¼"	10"	96.3°	28	—	20

<p>How to specify — Select the Model Number from above.</p> <p>C S C -</p>	<p>1st Option: Select the Glide or Caster:</p> <p>0 Nylon 1 Nickel (add \$19) 2 Felt (add \$19) 3 Multi-surface Casters</p>	<p>2nd Option: Select the Frame Finish:</p> <p>P71 Black PR6 Silver P8X Solar Black P8T Titanium</p>	<p>7th Option: Select the Mesh:</p> <p>FWM55 Black FWM75 Charcoal FWM80 Titanium FWM85 Salt FWM65 Brownstone FWM60 Regatta</p>	<p>4th Option: Select the Centurion Upholstery Color Code from page 17 for Upholstered Mesh Models (if applicable):</p> <p>C U .</p>	<p>5th Option: Select the Seat Upholstery:</p> <p>See pages 13-14 for selections, colors, and codes.</p>
---	--	---	---	---	---

Examples: CSC-UUCONO.3.P71.CU22.CU22 CSC-MUGONO.0.P71.FWM55.AI42

LYRIC

Lyric multi-purpose chairs go with the flow of your business. They're light, yet durable, so you can easily shift from one meeting to the next. Choose a bright shell color to create a bold look, or play it safe with a neutral color that blends seamlessly with your space. For whatever awaits, write the next line with Lyric, the family of chairs that fit everywhere.

MODELS AND OPTIONS

Lyric multi-purpose work chairs are constructed of a poly back and seat. Upholstered seat pad models available. Choose either arm or armless models.

The versatile multi-surface casters are designed for use on hard or soft surfaces.

MATERIALS

- All COMs/COLs must be approved for upholsterability or applicable fire code compliance prior to order entry. See pages 6-8 for COM ordering instructions.
- Allsteel fabrics meet requirements for CTB117. COM/COL manufacturers supply certificates of compliance for fabric only tests such as CTB117.
- Lyric multi-purpose work chairs are warranted for users up to 300 lbs.

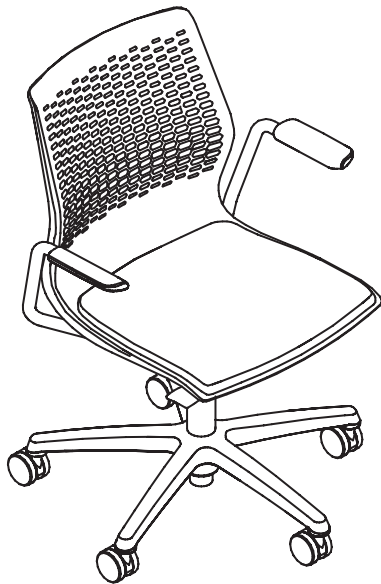

CMPWU-PPCONO — Poly Back with Upholstered Seat Pad and Casters

OPTIONS - MULTI-PURPOSE WORK CHAIR

Chair Types:

CMPW Multi-Purpose Work Chair

CMPWU Multi-Purpose Work Chair w/Upholstered Seat Pad

Back Material:

PP Polymer Back

Casters:

C Casters

Arms:

O Fixed Arm

A Armless

Fire code:

NO No Fire Code

Type of Caster:

B Black Dual-Wheel Multi-Surface Caster

T Titanium Multi-Surface Caster (add \$64)

Arm Cap:

H Non-flexible

Frame Color:

P71 Black

P8X Solar Black

PR6 Silver

P8T Titanium

Base Color:

BLK Black

TI Titanium

Polymer Colors:

BW Brownstone

QR Quarry

CI Citrine

RE Regatta

CP Calypso

S Flint

CR Cherry

SN Sienna

CY Cyprus

ST Salt

GE Sage

TI Titanium

HR Harbor

UM Umber

HZ Haze

WT White

LA Lava

ZE Zest

Cylinder:

2 Standard, allows 5¼" of travel





3 Short, allows 4½" of travel

Seat Upholstery:

See pages 13-14 for selections, colors, and codes.

FLOOR COVERING	TYPE OF GLIDE			
	Polycarbonate/Nylon	Felt	Steel	Rubber
Carpet	Best	Not Recommended	Good	Not Recommended
Polished Concrete	Best	Good	Not Recommended	Not Recommended
Hardwood	Not Recommended	Best	Not Recommended	Good
Vinyl (Includes LVT)	Best	Better	Good	Good
VCT	Best	Good	Not Recommended	Good
Tile (Porcelain/Ceramic)	Best	Good	Not Recommended	Good
Attention	Particles can become lodged in nylon and mar floor surface.	Particles can become lodged in felt and mar floor surface.	Cleaning chemicals and water can cause rusting.	Resists moving/sliding. Could lead to chairs tipping back.

(See page 148 for COM pricing on Grades 9-22)

Description	Back and Seat	Number	1	2	3	4	5	6	7	8	L1	L2
Arms 	Poly	CMPW-PPCONO	\$ 871									
Arms 	Poly w/Upholstered Seat Pad	CMPWU-PPCONO	\$ 1028	\$ 1053	\$ 1073	\$ 1095	\$ 1120	\$ 1147	\$ 1169	\$ 1196	\$ 1272	\$ 1422
Armless 	Poly	CMPW-PPCANO	\$ 735									
Armless 	Poly w/Upholstered Seat Pad	CMPWU-PPCANO	\$ 891	\$ 916	\$ 936	\$ 958	\$ 983	\$ 1010	\$ 1032	\$ 1059	\$ 1135	\$ 1285

LYRIC

Model Number	Overall				Seat				Armrests				Backrest					
	COM Package (seat only)	Height	Width	Depth	Height	Width	Depth	Pan Angle	Height	Width Between Arms	Arm Pad Width	Height	Width	Lumbar Height	Backrest/Seat Angle (Range)	Ship Weight Per Chair	Ship Weight Per Carton	Cubes
CMPW-PPCONO		36½"	24½"	23"	19 - 24¼"	18"	16½"	5°	8½"	20½"	2"	18"	17½"	7¼"	95°	29	—	18.3
CMPWU-PPCONO	0.60	36½"	24½"	23"	19 - 24¼"	18"	16¼"	5°	8½"	20½"	2"	18"	17½"	7¼"	95°	31	—	18.3
CMPW-PPCANO		36½"	24½"	23"	19 - 24¼"	18"	16½"	5°	8½"	20½"	2"	18"	17½"	7¼"	95°	26	—	18.3
CMPWU-PPCANO	0.60	36½"	24½"	23"	19 - 24¼"	18"	16¼"	5°	8½"	20½"	2"	18"	17½"	7¼"	95°	28	—	18.3

How to specify — Select the Model Number from above. CMPW- .	1st Option: Select the Caster: B Black Dual-Wheel Multi-surface Casters T Titanium Dual-Wheel Multi-surface Casters (\$64 extra)	2nd Option: Select the Arm Cap (if applicable): H Non-flexible	3rd Option: Select the Frame Finish: P71 Black PR6 Silver P8X Solar Black P8T Titanium	4th Option: Select the Base Color: BLK Black TI Titanium	5th Option: Select the Polymer Color: BW Brownstone CI Citrine CP Calypso CR Cherry CY Cyprus GE Sage HR Harbor HZ Haze LA Lava QR Quarry RE Regatta S Flint SN Sienna ST Salt TI Titanium UM Umber WT White ZE Zest	6th Option: Select the Cylinder: 2 Standard, allows 5¼" of travel 3 Short, allows 4½" of travel	7th Option: Select the Seat Pad Upholstery (if applicable): See pages 13-14 for selections, colors, and codes.
	.	.	H .	P

Examples: CSC-UUCONO.0.P71.CU22.CU22 CSC-MUCONO.0.P71.AM01.AI42

Lyric multi-purpose chairs go with the flow of your business. They're light, yet durable, so you can easily shift from one meeting to the next. Stow some away for the department lunch and learn. Then pull more off a stack to set up for the all-company awards celebration. Choose a bright shell color to create a bold look, or play it safe with a neutral color that blends seamlessly with your space. For whatever awaits, write the next line with Lyric, the family of chairs that fit everywhere.

Chairs ship up to four per carton to minimize waste. Model numbers and prices are per chair.

Lyric multi-purpose chairs are warranted for users up to 300 lbs.

KEY FEATURES

The perforated back on Lyric multi-purpose chair provides ventilation and distributed support. The waterfall seat front reduces pressure points and the intuitive back design offers built-in lumbar support.

MODELS AND OPTIONS

Arm and armless models available. Shell color options from sophisticated to playful and leg options from sled-base to four-legged with casters or glides.

Glide options include nylon, polycarbonate, nickel-plated, or felt. Nylon glides are recommended for hard surfaces, commercial carpet, and damp environments. Nickel-plated glides are recommended for carpet. Felt glides are recommended for wood, tile, or high-sheen floor surfaces.

Multi-surface casters are also available on four leg models and are designed for use on hard or soft surfaces.

Lyric 4-Leg Multi-Purpose chairs offer the ability to stack up to four chairs high on the floor.

Lyric Wire Stacker Multi-Purpose chairs offer the ability to stack up to ten high on the floor.

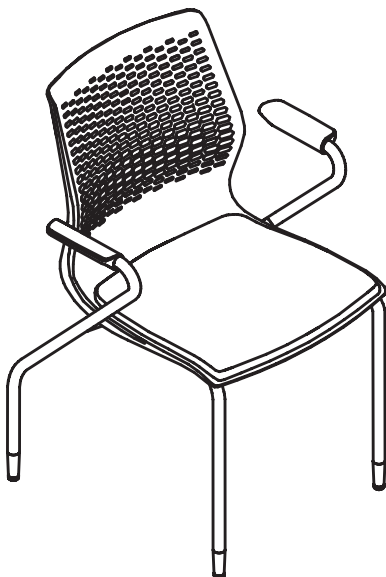

CMPNU-PPGO
4 Leg w/Seat Pad

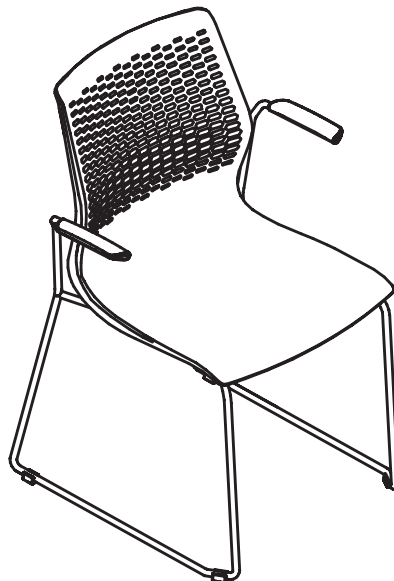

CWS-PPGO
Wire Stacker

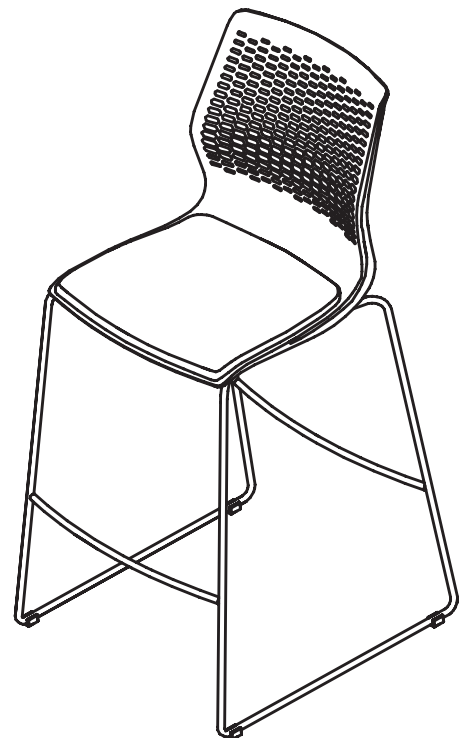

CWSS30U-PPGA
Wire Stool
w/Seat Pad

OPTIONS — MULTI-PURPOSE

Chair Types:

- CMPN** Four Leg Multi-Purpose Polymer Chair
- CMPNU** Four Leg Multi-Purpose Polymer Chair with Upholstered Seat Pad
- CWS** Wire Stacker Multi-Purpose Polymer Chair
- CWSU** Wire Stacker Multi-Purpose Polymer Chair with Upholstered Seat Pad
- CMSS30** Wire Multi-Purpose Polymer Stool
- CMSS30U** Wire Multi-Purpose Polymer Stool with Upholstered Seat Pad

Back Material:

- PP** Polymer Back

Casters/Glides:

- C** Casters
- G** Glides

Arms:

- O** Fixed
- A** Armless

Fire code:

- NO** No Fire Code

Type of Glide or Caster:

- 0** Nylon Glide (four leg models only)
- 0** Polycarbonate (wire stacker and stool models only)
- 1** Nickel Glide (\$19 extra)
- 2** Felt Glide (\$19 extra)
- 5** Rubber Glide (four leg models only, \$19 extra)
- 3** Multi-Surface Caster (four leg models only)

Arm Cap:

- H** Non-flexible (color predetermined based on finish selection, wire stacker arm caps are always black)

Frame Finish (Arm Cap color):

- P71** Black (Black)
- PJF** Bullseye (Titanium)
- PJW** Designer White (Titanium)
- P02** Flint (Black)
- PJE** Pyrite (Black)
- PR6** Silver (Titanium)
- P8X** Solar Black (Black)
- P8T** Titanium (Titanium)

Polymer Colors:

- | | |
|----------------------|--------------------|
| BW Brownstone | QR Quarry |
| CI Citrine | RE Regatta |
| CP Calypso | S Flint |
| CR Cherry | SN Sienna |
| CY Cyprus | ST Salt |
| GE Sage | TI Titanium |
| HR Harbor | UM Umber |
| HZ Haze | WT White |
| LA Lava | ZE Zest |



Upholstery Pad:

See pages [13-14](#) for selections.

See pages [17-19](#) for colors and codes

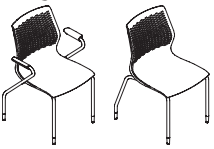
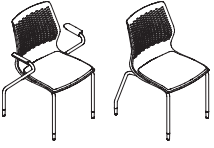
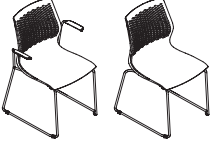
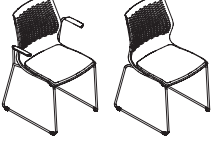

(See page 148 for COM pricing on Grades 9-22)

Base and Arms	Arms and Glides or Casters	Model Number	1	2	3	4	5	6	7	8	Leather*	
											1	2
4 Leg 	Arms with Glides	CMPN-PPGO	\$ 570									
	Arms with Casters	CMPN-PPCO	\$ 615									
	Armless with Glides	CMPN-PPGA	\$ 433									
	Armless with Casters	CMPN-PPCA	\$ 438									
4 Leg w/Seat Pad 	Arms with Glides	CMPNU-PPGO	\$ 699	\$ 723	\$ 743	\$ 765	\$ 789	\$ 815	\$ 835	\$ 863	\$ 935	\$ 1082
	Arms with Casters	CMPNU-PPCO	\$ 745	\$ 769	\$ 789	\$ 811	\$ 835	\$ 861	\$ 881	\$ 909	\$ 981	\$ 1128
	Armless with Glides	CMPNU-PPGA	\$ 564	\$ 588	\$ 608	\$ 630	\$ 654	\$ 680	\$ 700	\$ 728	\$ 800	\$ 947
	Armless with Caster	CMPNU-PPCA	\$ 609	\$ 633	\$ 653	\$ 675	\$ 699	\$ 725	\$ 745	\$ 773	\$ 845	\$ 992
Wire Stacker 	Arms with Glides	CWS-PPGO	\$ 655									
	Armless with Glides	CWS-PPGA	\$ 518									
Wire Stacker w/Seat Pad 	Arms with Glides	CWSU-PPGO	\$ 799	\$ 824	\$ 844	\$ 866	\$ 891	\$ 918	\$ 940	\$ 967	\$ 1043	\$ 1193
	Armless with Glides	CWSU-PPGA	\$ 661	\$ 686	\$ 706	\$ 728	\$ 753	\$ 780	\$ 802	\$ 829	\$ 905	\$ 1055
Wire Stool 	Armless with Glides	CWSS30-PPGA	\$ 655									
Wire Stool w/Seat Pad 	Armless with Glides	CWSS30U-PPGA	\$ 807	\$ 832	\$ 852	\$ 874	\$ 899	\$ 926	\$ 948	\$ 975	\$ 1051	\$ 1201

Continued on next page ►

<p>How to specify — Select the Model Number from above.</p>	<p>1st Option: Select the Glide or Caster:</p> <ul style="list-style-type: none"> 0 Nylon Glide (4 leg models only) 0 Polycarbonate (wire stacker models only) 1 Nickel Glide (\$19 extra) 2 Felt Glide (\$19 extra) 5 Rubber Glide (4 leg models only, \$19 extra) 3 Multi-Surface Caster (4 leg models only) 	<p>2nd Option: Arm Cap (if applicable):</p> <p>H Non-flexible</p> <p>Color predetermined based on finish selection, see page 99.</p>	<p>3rd Option: Frame Finish:</p> <ul style="list-style-type: none"> P71 Black PJF Bullseye PJW Designer White P02 Flint PJE Pyrite PR6 Silver P8X Solar Black P8T Titanium
<p>C - P P N O . .</p>		<p>H .</p>	<p> .</p>

Examples: CMPN-PPGONO.1.H.PR6.CR CWSU-PPGANO.0.H.P8X.WT.CU22

Model Number	COM Yardage			Overall			Seat			Armrests			Backrest			Ship Weight	Ship Weight Per Carton	Cubes		
	COL Sq. Feet	Height (Range)	Width	Depth	Height Std (Range)	Width	Depth	Pan Angle (Range)	Armrest Height	Width Between Arms	Depth	Height	Width	Lumbar Height	Backrest Seat Angle (Range)					
CMPN-PPGO			34"	24"	20½"	17¼"	18"	16¼"	6.6°	9"	20¼"	6½"	18¼"	17"	9¼"	93½°-99¼°	14	62	20	4 per carton
CMPN-PPCO			34"	24"	20½"	17¼"	18"	16¼"	6.6°	9"	20¼"	6½"	18¼"	17"	9¼"	93½°-99¼°	14	62	20	4 per carton
CMPN-PPGA			34"	24"	20½"	17¼"	18"	16¼"	6.6°				18¼"	17"	9¼"	93½°-99¼°	12	54	20	4 per carton
CMPN-PPCA			34"	24"	20½"	17¼"	18"	16¼"	6.6°				18¼"	17"	9¼"	93½°-99¼°	12	54	20	4 per carton
CMPNU-PPGO	0.6	6	34"	24"	20½"	17¼"	18"	16¼"	6.6°	9"	20¼"	6½"	18¼"	17"	9¼"	93½°-99¼°	14	62	20	4 per carton
CMPNU-PPCO	0.6	6	34"	24"	20½"	17¼"	18"	16¼"	6.6°	9"	20¼"	6½"	18¼"	17"	9¼"	93½°-99¼°	14	62	20	4 per carton
CMPNU-PPGA	0.6	6	34"	24"	20½"	17¼"	18"	16¼"	6.6°				18¼"	17"	9¼"	93½°-99¼°	12	54	20	4 per carton
CMPNU-PPCA	0.6	6	34"	24"	20½"	17¼"	18"	16¼"	6.6°				18¼"	17"	9¼"	93½°-99¼°	12	54	20	4 per carton
CWS-PPGO			34"	23¾"	22¼"	17¼"	18"	16¼"	6.6°	9"	20¼"	6½"	18¼"	17"	9¼"	93½°-99¼°	16	70	20	4 per carton
CWS-PPGA			34"	19"	22¼"	17¼"	18"	16¼"	6.6°	9"	20¼"	6½"	18¼"	17"	9¼"	93½°-99¼°	15	66	20	4 per carton
CWSU-PPGO	0.60		34"	21"	21½"	17¼"	18"	16¼"	6.6°	9"	20¼"	6½"	18¼"	17"	9¼"	93½°-99¼°	16	70	20	4 per carton
CWSU-PPGA	0.60		34"	21"	21½"	17¼"	18"	16¼"	6.6°	9"	20¼"	6½"	18¼"	17"	9¼"	93½°-99¼°	15	66	20	4 per carton
CWSS30-PPGA			46"	21½"	26"	33"	18"	16½"	5°				18"	17½"	7¼"	95°-101°	26		20	
CWSS30U-PPGA	0.60		46"	21½"	26"	33"	18"	16½"	5°	—	—	—	18"	17½"	7¼"	95°-101°	28		20	

Note: Lyric Multi-Purpose chairs ship up to four per carton to minimize waste. Chairs stack on floor up to 10-high. Model numbers and prices are per chair.

◀ Continued from previous page

<p>4th Option: Select the Poly Shell Color:</p> <p>BW Brownstone QR Quarry CI Citrine RE Regatta CP Calypso S Flint CR Cherry SN Sienna CY Cyprus ST Salt GE Sage TI Titanium HR Harbor UM Umber HZ Haze WT White LA Lava ZE Zest</p>	<p>5th Option: Select the Seat Pad Upholstery (if applicable):</p> <p>See pages 13-14 for selections, colors, and codes.</p>
---	---



Mimeo seating from Allsteel is designed to move with you. Created for today's active workplace, active workstyles, and active sitting, Mimeo is responsive and supportive of your every move. It hugs you. Embraces you. Envelops you. No matter your task. No matter your size or shape. Mimeo becomes one with you.

Designed in partnership with Bruce Fifield of Studio Fifield, Milan, Italy

Visually moving.

Mimeo's distinctive design and smart use of materials make a strong visual impact. It's appropriately scaled to impress and inspire across an open floorplan without overwhelming the environment. Comfortably moving from one space to the next, it brings style and character wherever it's used.

Always the right fit.

Mimeo's lightweight and intuitive design adapts to any type of work you're doing. Experience immediate and lasting comfort for focused work, as well as in project rooms and open desk areas where activities change day to day or hour to hour. Mimeo is ideal for highly active and collaborative workstyles and enhances every space.

Uncompromised comfort and support.

Mimeo's enveloping shape and dynamic back maintain constant contact with you, reducing and evenly distributing pressure points across the entire frame. No matter how you sit or move, the weight-activated motion adjusts automatically. Your whole body is supported. And each user, regardless of size, shape, or posture, has the same supportive experience.

A new standard in weight activation

Mimeo's recline tension has been engineered to automatically adjust to the specific needs and body weight of each user without the need for manual adjustment.

The innovative weight-activated chair motion delivers the appropriate amount of tension for full recline, upright sitting, and every posture in between. As you effortlessly recline, the seat lifts your bodyweight, which modifies the amount of tension accordingly. The result is a personalized, balanced recline that allows for comfortable and healthy movement for any body, in any posture.



MIW-KWNO



MIS-KWNO

DESIGN FEATURES

Mimeo's innovative back-pattern design provides integrated lumbar support while accommodating every movement. The generous seat width and slightly curved arms invite unrestricted movement and comfort for all postures and body types. Mimeo is lightweight and easy to transport with an integrated back handle, bringing function to any space, effortlessly.

IntelliForm™ back technology

Exclusive technology combines the benefits of the compliant, polymer back with flex wings, supportive uprights, and the soft, breathable Mimeo mesh material. The innovative back design and carefully selected materials have been engineered to deliver personalized comfort for each user, even as they move and change postures. The polymer back is highly pliable, allowing the material to flex and move along with the user.

Optional adjustable lumbar support

Mimeo provides automatic lumbar support. To accommodate personal preference, an optional external lumbar support can be added at any time with 4" range of adjustment.

4D adjustable arms

Mimeo's open arm design moves with you as you recline to support your arms in a variety of postures. Adjustments in four directions allow support during work tasks, and the ability to position arms close to the body.

Pneumatic seat height adjustment

Regulates height of work chair relative to the floor. Standard 5" of travel accommodates average to tall users. Stools offer 10" of travel.

Base and casters

Work chair bases are a five-star design. Dual-wheel casters are available in hard tread for carpet, or multi-surface for any floor surface.

Materials

- All COMs/COLs must be approved for upholsterability or applicable fire code compliance prior to order entry. See pages 6-8 for COM ordering instructions.
- Allsteel fabrics meet requirements for CTB117. COM/COL manufacturers supply certificates of compliance for fabric-only tests such as CTB117.
- Mimeo meets the requirements set forth in ANSI/BIFMA X5.1-2011 and BIFMA G1-2013. Mimeo is warranted for multiple shifts and users up to 300 lbs.

Height-Adjustable Footring

Travels 8" to ensure users have comfortable support of their feet and legs. The footring has a 20" diameter.

OPTIONS — WORK/CONFERENCE

Chair Type:

MIW Work Chair**MIS** Work Stool

Back:

K Knit

Armrests:

W 4D Adjustable Arms**A** Armless

Fire Code:

NO No Fire Code

Frame Color:

BLK Black**T** Titanium (add \$80)

Base Color:

BLK Black**T** Titanium**PAL** Polished Aluminum (add \$164)

Back Carrier Color Option

BLK Black**G** Graphite**T** Titanium**WT** White

Lumbar (color matches back carrier):

N No Lumbar Adjustment**L** Lumbar Adjustment (add \$74)

Cylinder:

2 Standard**3** Short**4** Extended (Stool Only)

Casters:

H Black Hard Tread**B** Black Multi-surface (add \$68)**T** Titanium Multi-surface (add \$68)



Mimeo Mesh Back Material:

NM61 Amethyst**NM91** Cobalt**NM19** Fog**NM27** Glow**NM75** Leaf**NM22** Loft**NM10** Onyx**NM20** Shadow

Upholstery:

See pages 13-14 for selections, colors, and codes.

(See page 149 for COM pricing on Grades 9-22)

Arm Style	Type	Model Number <i>Add options below</i>									Leather*	
			1	2	3	4	5	6	7	8	1	2
Fully Adjustable Arms 	Work	MIW-KWNO	\$ 2041	\$ 2061	\$ 2078	\$ 2099	\$ 2124	\$ 2148	\$ 2170	\$ 2194	\$ 2364	\$ 3223
	Stool	MIS-KWNO	\$ 2467	\$ 2487	\$ 2504	\$ 2525	\$ 2550	\$ 2574	\$ 2596	\$ 2620	\$ 2790	\$ 3649
Armless 	Work	MIW-KANO	\$ 1758	\$ 1778	\$ 1795	\$ 1816	\$ 1841	\$ 1865	\$ 1887	\$ 1911	\$ 2081	\$ 2940
	Stool	MIS-KANO	\$ 2184	\$ 2204	\$ 2221	\$ 2242	\$ 2267	\$ 2291	\$ 2313	\$ 2337	\$ 2507	\$ 3366
Lumbar Kit		MLUK	\$ 146									

Continued on next page ►

<p>How to specify — Select the Model Number from above.</p>	<p>1st Option Select the Frame Color (if applicable):</p> <p>BLK Black T Titanium (\$80 extra)</p>	<p>2nd Option: Select the Base Color (if applicable):</p> <p>BLK Black T Titanium PAL Polished Aluminum (\$164 extra)</p>	<p>3rd Option: Select the Back Carrier Color:</p> <p>BLK Black G Graphite T Titanium WT White</p>	<p>4th Option: Select the Lumbar (color matches back carrier):</p> <p>N No Lumbar L Lumbar (\$74 extra)</p>	<p>5th Option: Select the Cylinder:</p> <p>2 Standard 3 Short 4 Extended (stool only)</p>
MI - K 					

Examples: MIW-KWNO.BLK.BLK.BLK.N.2.H.NM10.NR66 MLUK.WT
MIS-KWNO.T.T.WT.L.4.T.NM22.PNS012

Model Number	COM Landage	COL Sq. Feet	Height (Range)	Width	Depth	Height	Width	Depth	Pan Angle (Range)	Armrest Height	Width Between Arms	Armrest Length	Arm Height to the Floor	Height	Width	Lumbar Height	Backrest/Seat Angle (Range)	Ship Weight	Ship Weight Per Carton	Cubes
MIW-KWNO	1.0	20	36" - 41"	23"	23"	16"-21"	20"	15" - 18"	4°	6" - 11"	13" - 21"	11"	22" - 32"	23"	18"	9"	95°-113°	31½	41	11.1
<i>Short Cylinder</i>			34" - 38"			14"-18"							21" - 29"							
MIS-KWNO	1.0	20	42" - 52"	23"	23"	22"-32"	20"	15" - 18"	4°	6" - 11"	13" - 21"	11"	28" - 43"	23"	18"	9"	95°-113°	41.5	45	12.6
MIW-KANO	1.0	20	36" - 41"	23"	23"	16"-21"	20"	15" - 18"	4°					23"	18"	9"	95°-113°	31½	41	11.1
<i>Short Cylinder</i>			34" - 38"			14"-18"														
MIS-KANO	1.0	20	42" - 52"	23"	23"	22"-32"	20"	15" - 18"	4°					23"	18"	9"	95°-113°	41.5	45	12.6

Note: Dimensions are in accordance with BIFMA G1-2013 guidelines — see illustration of guidelines on page 45.

◀ Continued from previous page

<p>6th Option: Select the Casters: H Black Hard Tread B Black Multi-surface (\$68 extra) T Titanium Multi-surface (\$68 extra)</p>	<p>7th Option: Select the Knit Color: NM61 Amethyst NM91 Cobalt NM19 Fog NM27 Glow NM75 Leaf NM22 Loft NM10 Onyx NM20 Shadow</p>	<p>8th Option: Select the Seat Upholstery: See pages 13-14 for selection. See pages 17-19 for colors and codes. See pages 6-8 for COM guidelines.</p>
---	---	---



Nimble is a high density stacking solution that is both extremely durable and surprisingly comfortable. Durable because we use the thickest wire frame in the industry. Comfortable because of the hidden front support bar, the contoured polypropylene back and seat along with the flexibility of the frame. The clean design will appeal to designers and facility managers alike.

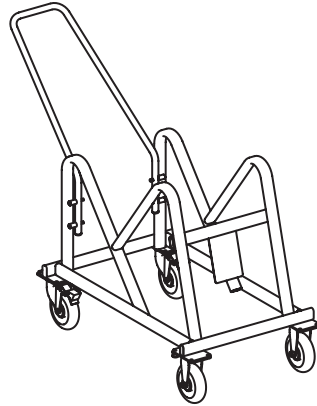
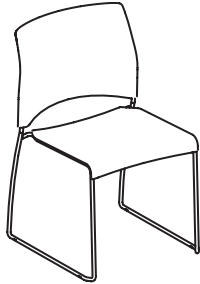

MODELS AND OPTIONS

The Nimble chair is suited for team conference, cafeterias, auditoriums, or visitor's chair applications.

Nimble **stacks 36 chairs high** in 66"H by 50"D by 22"W (on a cart). A maximum of 12 chairs can be stacked without a cart with a dimension of 40"H by 33"D by 19½"W.

The **cart** is available in black epoxy paint finish with black casters. The cart angles chairs in a neat vertical arrangement that fits through doorways and can be moved by one person. Carts are shipped one per carton.

SEATS AND BACKS

The seat features a **waterfall** edge to *enhance circulation* and *reduce fatigue*. The backrest features contoured **lumbar** support to help *relieve stress in the spine*.

The **seat and backrest shells** are color-impregnated, washable polypropylene with U.V. inhibitors.

The polypropylene shells are easily **field replaceable** with simple hand tools for long life.

GLIDES

Nimble offers glide options for different types of flooring.

Polycarbonate glide is standard and well-suited for carpet and vinyl flooring.

Stainless steel glide can provide extra protection when used on rough, gritty, or hard surfaces (concrete).

Felt-covered polycarbonate glide is recommended for wood, tile, or high-sheen gloss floor surfaces to protect the finish longer.

GANGING BRACKETS

Brackets securely connect Nimble chairs together for a neat, aligned row. The brackets are snapped in place over the chair glide (two brackets per chair). To connect the chairs, snap the bracket from one chair leg to the adjacent chair leg. To disconnect, unsnap the bracket. The chairs stack with the brackets in place.

[GSA Reference Page](#)

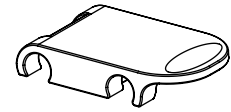

Brackets are sold in packages of eight (for four chairs). The brackets can be added to Nimble chairs at any time.

FRAMES

The sturdy, **12mm wire frame** provides clean lines and excellent strength, ideal for high-density stacking.

The **chrome, black or silver epoxy powder-coated frame** is durable and scuff-resistant and complements any environment.

Powder coating is a non-hazardous and solvent-free process which provides an environmentally friendly, baked-on, durable finish. **Chrome** is recommended for high-intensity stacking applications due to its chip-resistant properties.

SHIPPING

Nimble chairs **ship in cartons containing 4 chairs** to reduce packaging waste.

STANDARDS

Nimble meets the requirements set forth in ANSI/BIFMA X5.1-2011. Nimble is warranted for users up to 300 lbs.

OPTIONS — NIMBLE SEATING:

Description:

- Stacking Chair
- Ganging Brackets (Black only)
- Cart for Stacking and Transportation

Upholstery Options:

- Polypropylene Shells

Glide Options:

- 0** Polycarbonate Glides
- 1** Stainless Steel Glides (\$30 extra per chair)
- 2** Felt Covered Polycarbonate Glides (\$19 extra per chair)

Frame Colors:

CBK Black	P8P Ember
P8T Titanium	P8N Ion
P8B Night Bronze	P8J Iris
PJE Pyrite	P8F Krypton
PR6 Silver	P8M Regatta
P8X Solar Black	P093 Ochre
P8S Atom	P092 Sienna
PJF Bullseye	

Carts are always Black.

Plastic Shell Colors:

Opaque Colors —

BLK Black (formerly CB Onyx)
BU Surf
BW Brownstone
GN Sprout
GY Summit
RD Cayenne
RG Tangelo
WT White (formerly Frost)

Description	Frame Finish	Model Number	List Price
Plastic Shells	Chrome	Open Market NMBL-1FC (<i>De-emphasized</i>)	\$ 358
	Powder Coat	Open Market NMBL-2FC (<i>De-emphasized</i>)	\$ 358
	Ganging Brackets	NMBL-GANG (Package of 8 brackets for 4 chairs – Black only) (<i>De-emphasized</i>)	\$ 95



Nimble chairs ship in cartons containing 4 chairs. Model numbers and price are per chair.

Model Number	Overall					Seat			Armrests				Backrest				Unit Weight	Ship Weight Per Carton	Cubes			
	COM Yardage	COL Sq. Feet	Height (Range)	Width	Depth	Height (Range)	Width	Depth (Range)	Pan Angle (Range)	Height (Range)	Width Between Armrests (Range)	Depth (Range)	Pivot Inwards	Pivot Outwards	Height (Range)	Width				Lumbar Height (Range)	Backrest/Seat Angle (Range)	
NMBL-1FC*	-	-	31 1/8"	19 1/4"	21 1/2"	18"	18"	17 1/2"	4°	-	-	-	-	-	16 1/2"	19"	6"	96°	15.0	65.0	11.9	4 per carton
NMBL-2FC*	-	-	31 1/8"	19 1/4"	21 1/2"	18"	18"	17 1/2"	4°	-	-	-	-	-	16 1/2"	19"	6"	96°	15.0	65.0	11.9	4 per carton
NMBL-GANG*	-	-	1/2"	3"	1 1/4"																0.6	0.1 package of 8

*De-emphasized

**Calculate 21"W per chair with ganging bracket.

Description	Dimensions	Model Number	List Price
Cart	29"H x 21"W x 34"D*	NMBL-CART (<i>De-emphasized</i>)	\$ 1114

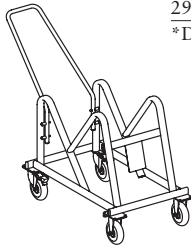

*Depth dimension above does not include the handle

<p>How to specify — Select the Model Number from above.</p>	<p>1st Option: Select the Glide (if applicable):</p> <p>0 Polycarbonate Glides 1 Stainless Steel Glide Caps (\$30 per chair extra) 2 Felt Covered Polycarbonate Glides (\$19 per chair extra)</p>	<p>2nd Option: Select the Frame Color (for NMBL-2FC only):</p> <table border="0"> <tr> <td>CBK Black</td> <td>P8P Ember</td> </tr> <tr> <td>P8T Titanium</td> <td>P8N Ion</td> </tr> <tr> <td>P8B Night Bronze</td> <td>P8J Iris</td> </tr> <tr> <td>PJE Pyrite</td> <td>P8F Krypton</td> </tr> <tr> <td>PR6 Silver</td> <td>P8M Regatta</td> </tr> <tr> <td>P8X Solar Black</td> <td>P093 Ochre</td> </tr> <tr> <td>P8S Atom</td> <td>P092 Sienna</td> </tr> <tr> <td>PJF Bullseye</td> <td></td> </tr> </table>	CBK Black	P8P Ember	P8T Titanium	P8N Ion	P8B Night Bronze	P8J Iris	PJE Pyrite	P8F Krypton	PR6 Silver	P8M Regatta	P8X Solar Black	P093 Ochre	P8S Atom	P092 Sienna	PJF Bullseye		<p>3rd Option: Select the Shell (seat and back) Color (if applicable):</p> <p>Opaque: BLK Black (formerly CB – Onyx) BU Surf BW Brownstone GN Sprout GY Summit RD Cayenne RG Tangelo WT White (formerly Frost)</p>
CBK Black	P8P Ember																		
P8T Titanium	P8N Ion																		
P8B Night Bronze	P8J Iris																		
PJE Pyrite	P8F Krypton																		
PR6 Silver	P8M Regatta																		
P8X Solar Black	P093 Ochre																		
P8S Atom	P092 Sienna																		
PJF Bullseye																			

Examples: NMBL-1FC.0.WT NMBL-2FC.2.P71.RD NMBL-CART

O6 is a task chair that answers the ergonomic demands and needs put forth by the user while addressing the mental well-being that is usually left behind in today's seating world. The workplace is about people and the furniture should be an extension of those individuals, not the other way around. O6 is the culmination of research that has deemed comfort, ergonomics, and fresh design language as keys to win.

KEY FEATURES

O6 chairs feature weight-activated recline so there's no additional tension adjustment. Intuitive controls, along with specially sculpted and formulated seat foam, create a comfortable sitting experience for wherever and however people work.

Customization

O6 allows for a wide range of color optionality. The O6 family is offered in two different meshes, totaling 29 distinct mesh colors. Coupled with 4 frame colors to choose from, O6 offers users the chance to make a design statement throughout their workspace.

4D Fully Adjustable Arms

O6's 4D arms are fully adjustable in height, width, depth, and can pivot to provide optimal support. Pivot the front of the arm pads inward to move in closer to your desk and offer support while working.

2D Adjustable Arms

Provides height and width adjustments for optimal support of elbows and shoulders while keyboarding or conferencing while providing ease of entry/exit.

Pneumatic Seat Height Adjustment

Regulates height of work chair relative to the floor. Standard 5" of travel accommodates average to tall users. Stools offer 10" of travel.

Seat Depth Adjustment

Allows seat cushion to manually adjust front to back.

Height-Adjustable Footring

Travels 8" to ensure users have comfortable support of their feet and legs. The footring has a 20" diameter.

Optional Adjustable Lumbar Support

To accommodate personal preference, an optional external lumbar support can be added at any time with 4" range of adjustment.

Base and Casters

Work chair bases are a five-star design. Dual-wheel casters are available in hard tread for carpet, or multi-surface for any floor surface.

Materials

- All COMs/COLs must be approved for upholsterability or applicable fire code compliance prior to order entry. See pages 6-8 for COM ordering instructions.
- Allsteel fabrics meet requirements for CTB117. COM/COL manufacturers supply certificates of compliance for fabric-only tests such as CTB117.
- O6 meets the requirements set forth on ANSI/BIFMA X5.1-2017 and BIFMA G1-2013. O6 is warranted for multiple shifts and users up to 300 lbs.

OPTIONS — WORK / STOOL

Chair Type:

MNL Work

MNLS Stool

Arms:

MHW 4D Fully Adjustable

MHH 2D Adjustable

MHA Armless

Frame Color:

BLK Black

TI Titanium (add \$46)

E9 Flint (add \$91)

STX Salt (add \$91)

Mesh Color:

FWM55 Black

FWM75 Charcoal

FWM80 Titanium

FWM85 Salt

FWM65 Brownstone

FWM60 Regatta

FWM90 Breeze

RM10 Carbon (add \$113)

RM11 Titanium (add \$113)

RM12 Loft (add \$113)

RM13 Onyx (add \$113)

RM14 Cobalt (add \$113)

RM15 Espresso (add \$113)

RM16 Brick (add \$113)

RM17 Bullseye (add \$113)

RM19 Sky (add \$113)

RM20 Blueberry (add \$113)

RM21 Leaf (add \$113)

RM23 Kermit (add \$113)

RM24 Midnight (add \$113)

RM25 Salamander (add \$113)

RM26 Steel (add \$113)

RM27 Beacon (add \$113)

RM28 Chalk (add \$113 Available on back only)

RM29 Pear (add \$113)

RM30 Linen (add \$113)

RM31 Gold Dust (add \$113)

RM32 Key Lime (add \$113)

RM33 Quicksand (add \$113)

Lumbar:

- L** Yes (add \$62)
- N** No

Cylinder:

- 2** Standard
- 3** Short
- 4** Stool



Base Color:

- BLK** Black
- TI** Titanium
- E9** Flint
- ST** Salt

Casters:

- H** Black Hard Tread
- B** Black Multi-Surface (add \$68)
- T** Titanium Multi-Surface (add \$68)
- E9** Flint Multi-Surface (add \$68)
- ST** Salt Multi-Surface (add \$68)

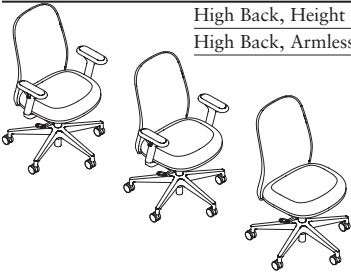
(See page 149 for COM pricing on Grades 9-22)

Back	Type	Model Number <i>Add options below</i>	Options 1-8								Leather	
			1	2	3	4	5	6	7	8	1	2
	High Back, 4D Adj Arms	MNL-MHW	\$ 1167	\$ 1188	\$ 1209	\$ 1227	\$ 1254	\$ 1282	\$ 1308	\$ 1334	\$ 1456	\$ 1662
	High Back, Height Adj Arms	MNL-MHH	\$ 1101	\$ 1122	\$ 1143	\$ 1161	\$ 1188	\$ 1216	\$ 1242	\$ 1268	\$ 1390	\$ 1596
	High Back, Armless	MNL-MHA	\$ 988	\$ 1009	\$ 1030	\$ 1048	\$ 1075	\$ 1103	\$ 1129	\$ 1155	\$ 1277	\$ 1483
	High Back, 4D Adj Arms	MNLS-MHW	\$ 1347	\$ 1368	\$ 1389	\$ 1407	\$ 1434	\$ 1462	\$ 1488	\$ 1514	\$ 1636	\$ 1842
	High Back, Height Adj Arms	MNLS-MHH	\$ 1280	\$ 1301	\$ 1322	\$ 1340	\$ 1367	\$ 1395	\$ 1421	\$ 1447	\$ 1569	\$ 1775
	High Back, Armless	MNLS-MHA	\$ 1167	\$ 1188	\$ 1209	\$ 1227	\$ 1254	\$ 1282	\$ 1308	\$ 1334	\$ 1456	\$ 1662
O6 Lumbar Kit		MNL-LUK	\$ 67									

<p>How to specify — Select the Model Number from above.</p> <p>_____ .</p>	<p>1st Option: Select the Frame Color:</p> <p>BLK Black TI Titanium (add \$46) E9 Flint (add \$91) STX Salt (add \$91)</p> <p>_____ .</p>	<p>2nd Option: Select the Mesh (if applicable):</p> <p>See page 108 for selection.</p> <p>_____ .</p>	<p>3rd Option: Select the Lumbar (if applicable):</p> <p>N No Lumbar L Lumbar (add \$62)</p> <p>_____ .</p>	<p>4th Option: Select the Cylinder (if applicable):</p> <p>2 Standard 3 Short 4 Stool</p> <p>_____ .</p>
---	--	--	--	---

<p>5th Option: Select the Base (if applicable):</p> <p>BLK Black TI Titanium E9 Flint ST Salt</p> <p>_____ .</p>	<p>5th Option: Select the Casters (if applicable):</p> <p>H Black Hard Tread B Black Multi-Surface (add \$68) T Titanium Multi-Surface (add \$68) E9 Flint Multi-Surface (add \$68) ST Salt Multi-Surface (add \$68)</p> <p>_____ .</p>	<p>7th Option: Select the Upholstery (if applicable):</p> <p>_____ .</p>	<p>8th Option: Select Headrest (if applicable):</p> <p>N No Headrest</p> <p>N</p>
---	--	---	---

Examples: MNL-MHW.BLK.RM10.N.2.BLK.H.CU10.N

Model Number	COM Landage			Overall			Seat				Armrests				Backrest					
	COL Sq. Feet	Height (Range)	Width	Depth	Height (Range)	Width	Depth (Range)	Pan Angle (Range)	Armrest Height	Width Between Arms	Depth (Range)	Pivot Inwards	Pivot Outwards	Height	Width	Lumbar Height*	Backrest/Seat Angle (Range)	Ship Weight	Ship Weight Per Carton	Curbs
MNL-MHW	0.81	37¼"-43"	26¼"	25½"	17"-22"	20½"	17½"-19½"	3°-8°	7½"-11½"	21"	10"	35"	35"	23"	17½"	4½"-9"	98°-111°	46	46	10.7
MNL-MHH	0.81	37¼"-43"	26¼"	25½"	17"-22"	20½"	17½"-19½"	3°-8°	7½"-11¼"	21"	10"	-	-	23"	17½"	4½"-9"	98°-111°	46	46	10.7
MNL-MHA	0.81	37¼"-43"	25½"	25½"	17"-22"	20½"	17½"-19½"	3°-8°	-	-	-	-	-	23"	17½"	4½"-9"	98°-111°	44	44	10.7
MNLS-MHW	0.81	45¼"-55¼"	26¼"	25½"	24½"-34½"	20½"	17½"-19½"	3°-8°	7½"-11½"	21"	10"	35"	35"	23"	17½"	4½"-9"	98°-111°	52	52	10.7
MNLS-MHH	0.81	45¼"-55¼"	26¼"	25½"	24½"-34½"	20½"	17½"-19½"	3°-8°	7¼"-11¼"	21"	10"	-	-	23"	17½"	4½"-9"	98°-111°	52	52	10.7
MNLS-MHA	0.81	45¼"-55¼"	25½"	25½"	24½"-34½"	20½"	17½"-19½"	3°-8°	-	-	-	-	-	23"	17½"	4½"-9"	98°-111°	50	50	10.7
MNL-LUK																				

Note: Dimensions are in accordance with BIFMA G1-2013 guidelines — see illustration of guidelines on page 45.

The Pli task seating portfolio provides distinctive performance and exceptional simplicity of movement. The innovative auto-fitting design enables each user to experience maximum ergonomic support for extended use without performing a series of multiple, complex adjustments. Sit, move, reach, work, and Pli adjusts to the movements and contours of each user.

KEY FEATURES

The crucial criterion for wellness is a seating portfolio that combines the ergonomic support you need with the comfort you should never be without. Every one of the Pli chair models adapts to dynamic user movements with simplicity and responsiveness, ensuring a seated posture that is both healthful and comfortable.

Minimal Adjustments

The distinctive 4-point seat suspension system ensures that Pli creates multi-position support without painstaking manual adjustments. Sit, and Pli conforms to you. The intuitive and easy height-adjustment control enables Pli to accommodate nearly every user stature. One adjustment is all you need to make.

Back Support

Each Pli seating model offers flexible and responsive edgeless back support that transcends rigid perimeters, moving with the movements of the user. The conforming mesh back offers support to the lumbar area throughout the sit.

2D Adjustable Arms

Provides height and width adjustments for optimal support of elbows and shoulders while keyboarding or conferencing while providing ease of entry/exit.

Fixed Arms

Provide basic support for users engaging in a variety of tasks throughout the day. Arms come with protective black, flint, titanium or salt urethane arm pads to match the specified frame finish. Fixed arms limit adjustability but provide consistent aesthetics in conference room settings.

Pneumatic Seat Height Adjustment

Regulates height of work chair relative to the floor. Standard 5" of travel accommodates average to tall users. Stools offer 10" of travel.

Height-Adjustable Footring

Travels 8" to ensure users have comfortable support of their feet and legs. The footring has a 20" diameter.

Base and Casters

Work chair bases are a five-star design. Dual-wheel casters are available in hard tread for carpet, or multi-surface for any floor surface.

Materials

- All COMs/COLs must be approved for upholsterability or applicable fire code compliance prior to order entry. See pages 6-8 for COM ordering instructions.
- Allsteel fabrics meet requirements for CTB117. COM/COL manufacturers supply certificates of compliance for fabric-only tests such as CTB117.
- Pli is warranted for multiple shifts and users up to 300 lbs.
- Pli meets the requirements set forth in ANSI/BIFMA X5.1-2011.

OPTIONS — WORK / STOOL

Chair Type:

- FWW** Work
- FWS** Stool

Arms:

- MHH** Height-Adjustable
- MHF** Fixed Arm
- MHA** Armless

Frame Color:

- BLK** Black
- TI** Titanium (add \$46)
- E9** Flint (add \$91)
- ST** Salt (add \$91)

Mesh Color:

- D** Dusk
- M** Mist
- L** Lustre
- N** Navy
- C** Clay

Cylinder:

- 2** Standard
- 3** Short
- 4** Stool

Base Color:

- BLK** Black
- TI** Titanium
- E9** Flint
- ST** Salt

Casters:

- H** Black Hard Tread
- B** Black Multi-Surface (add \$68)
- T** Titanium Multi-Surface (add \$68)
- E9** Flint Multi-Surface (add \$68)
- ST** Salt Multi-Surface (add \$68)

(See page 149 for COM pricing on Grades 9-22)

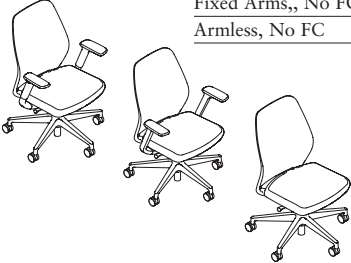
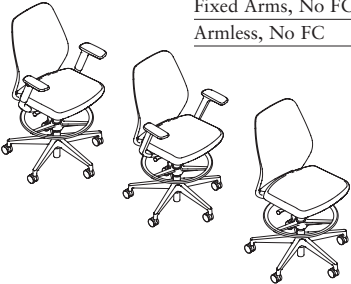
Back	Type	Model Number <i>Add options below</i>									Leather	
			1	2	3	4	5	6	7	8	1	2
	Height Adj. Arms, No FC	FWW-MHHNO	\$ 1396	\$ 1418	\$ 1440	\$ 1461	\$ 1489	\$ 1517	\$ 1545	\$ 1574	\$ 1702	\$ 1922
	Fixed Arms, No FC	FWW-MHFNO	\$ 1360	\$ 1382	\$ 1404	\$ 1425	\$ 1453	\$ 1481	\$ 1509	\$ 1538	\$ 1666	\$ 1886
	Armless, No FC	FWW-MHANO	\$ 1217	\$ 1239	\$ 1261	\$ 1282	\$ 1310	\$ 1338	\$ 1366	\$ 1395	\$ 1523	\$ 1743
	Height Adj. Arms, No FC	FWS-MHHNO	\$ 1754	\$ 1776	\$ 1798	\$ 1819	\$ 1847	\$ 1875	\$ 1903	\$ 1932	\$ 2060	\$ 2280
	Fixed Arms, No FC	FWS-MHFNO	\$ 1718	\$ 1740	\$ 1762	\$ 1783	\$ 1811	\$ 1839	\$ 1867	\$ 1896	\$ 2024	\$ 2244
	Armless, No FC	FWS-MHANO	\$ 1575	\$ 1597	\$ 1619	\$ 1640	\$ 1668	\$ 1696	\$ 1724	\$ 1753	\$ 1881	\$ 2101

<p>How to specify — Select the Model Number from above.</p> <p>_____ .</p>	<p>1st Option: Select the Frame Color:</p> <p>BLK Black TI Titanium (add \$46) E9 Flint (add \$91) ST Salt (add \$91)</p> <p>_____ .</p>	<p>2nd Option: Select the Mesh (if applicable):</p> <p>D Dusk M Mist L Lustre N Navy C Clay</p> <p>_____ .</p>	<p>3rd Option: Select the Cylinder (if applicable):</p> <p>2 Standard 3 Short 4 Stool</p> <p>_____ .</p>	<p>4th Option: Select the Base (if applicable):</p> <p>BLK Black TI Titanium E9 Flint ST Salt</p> <p>_____ .</p>
---	---	---	---	---

<p>5th Option: Select the Casters (if applicable):</p> <p>H Black Hard Tread B Black Multi-Surface (add \$68) T Titanium Multi-Surface (add \$68) E9 Flint Multi-Surface (add \$68) ST Salt Multi-Surface (add \$68)</p> <p>_____ .</p>	<p>7th Option: Select the Upholstery (if applicable):</p> <p>_____ .</p>
--	---

Examples: FWW-MHHNO.BLK.D.2.BLK.H.CU10

Model Number	COM Package			Overall			Seat			Armrests			Backrest			Shipping		Cubes
	COI Sq. Feet	Height (Range)	Width	Depth	Height (Range)	Width	Depth (Range)	Pan Angle (Range)	Armrest Height	Width Between Arms	Depth (Range)	Height	Width	Lumbar Height	Backrest/Seat Angle (Range)	Ship Weight	Ship Weight Per Carton	
FWW-MHHNO	0.77	37"-42"	27½"	25"	15"-20"	19"	17¼"	1½°-11°	7¼"-11½"	21"	8½"	22¼"	18¾"	10¼"	96°-122°	36	36	12.1
FWW-MHFNO	0.77	37"-42"	27½"	25"	15"-20"	19"	17¼"	1½°-11°	9¼"	21"	8½"	22¼"	18¾"	10¼"	96°-122°	35	35	12.1
FWW-MHANO	0.77	37"-42"	25"	25"	15"-20"	19"	17¼"	1½°-11°	-	-	-	22¼"	18¾"	10¼"	96°-122°	30	30	12.1
FWS-MHHNO	0.77	44"-54"	28"	26"	22"-31¼"	19"	17¼"	1½°-11°	7¼"-11½"	21"	8½"	22¼"	18¾"	10¼"	96°-122°	41	41	12.1
FWS-MHFNO	0.77	44"-54"	28"	26"	22"-31¼"	19"	17¼"	1½°-11°	9¼"	21"	8½"	22¼"	18¾"	10¼"	96°-122°	40	40	12.1
FWS-MHANO	0.77	44"-54"	26"	26"	22"-31¼"	19"	17¼"	1½°-11°	-	-	-	22¼"	18¾"	10¼"	96°-122°	35	35	12.1

Note: Dimensions are in accordance with BIFMA G1-2013 guidelines — see illustration of guidelines on page 45.

There is one frame finish (black) and one mesh color (carbon) for Quip. Quip acts as a clever commentary on your company's personality.

Exceed expectations, not your budget.

Quip is the prize fighter of work chairs. This is a hard-working, no-nonsense chair that supports you through heads-down work, lunch breaks, and whatever else the day brings.

All comfort. No fuss.

Easy-to-use adjustments, including seat depth, make Quip a comfortable sit.

1. Height-adjustable arms adjust side-to-side and front-to-back.
2. Intuitive standard controls include height adjustment, tilt tension, tilt lock, and seat depth, an adjustment that customizes the chair to your body.
3. Lumbar support has been engineered into the back. Optional lumbar support allows users to adapt the chair to their needs with minimal effort.

DESIGN FEATURES

The jack-of-all-trades functionality you need.
The attention-commanding look everyone loves.
Quip wraps it all up in one smart investment.

Frame finishes

A Black finish pairs with a carbon mesh and a black upholstery color for a stylish chair.

Fully Adjustable Arms

Fully adjustable arms adjust up and down with armpads that adjust side-to-side and front-to-back to allow support during work tasks.

Optional adjustable lumbar support

Adjustable lumbar support to accommodate personal preference. An optional external lumbar support can be added at any time.

Pneumatic seat height adjustment

Regulates height of work chair relative to the floor. Standard 5" of travel accommodates average to tall users.

Base and Casters

Work chair bases are a five-star design. Dual-wheel casters are available in hard tread for carpet.

Materials

- All COMs/COLs must be approved for upholsterability or applicable fire code compliance prior to order entry. See pages 6-8 for COM ordering instructions.
- Allsteel fabrics meet requirements for CTB117. COM/COL manufacturers supply certificates of compliance for fabric-only tests such as CTB117.
- Quip meets the requirements set forth in ANSI/BIFMA X5.1-2011 and BIFMA G1-2013. Quip is warranted for multiple shifts and users up to 300 lbs.

OPTIONS — BASIC WORK

- LST** Basic Work
- Fire Code:
 - NO** No Fire Code
- Frame Color:
 - BLK** Black
- Arms:
 - W** Fully Adjustable
- Lumbar:
 - L** Lumbar Adjustment
- Cylinder:
 - 2** Standard
- Casters:
 - H** Black Hard Tread
- Quip Mesh:
 - SBM01** Carbon
- Upholstery:
 - QLB10** Black

(See page 149 for COM pricing on Grades 9-22)

Back	Type	Model Number Add options below									Leather			
			1	2	3	4	5	6	7	8	1	2		
Mesh	Basic Work	LSTNO	\$ 856											



QUIP

Model Number	Overall			Seat		Armrests			Backrest									
	COL Sp. Feet Height (Range)	Width	Depth	Height	Width	Depth	Pan Angle (Range)	Armrest Height	Width Between Arms	Armrest Length	Arm Height to the Floor	Height	Width	Lumbar Height	Backrest/Seat Angle (Range)	Ship Weight Per Carton	Cubics	
LST	20	38" - 43 1/2"	26"	26"	16" - 21"	19 1/2"	15 1/4" - 17 1/2"	10°	8 1/2"	20 1/2"	6"	24 1/4" - 29 1/8"	24"	17"		96° - 110°	46	11.1

Note: Dimensions are in accordance with BIFMA G1-2013 guidelines — see illustration of guidelines on page 45.

<p>How to specify — Select the Model Number from above.</p> <p>L S T N O .</p>	<p>1st Option: Select the Frame Color: BLK Black</p> <p>B L K .</p>	<p>2nd Option: Select the Arms (if applicable): W Fully Adjustable</p> <p>W .</p>	<p>3rd Option: Select the Lumbar (if applicable): L Lumbar</p> <p>L .</p>	<p>4th Option: Select the Cylinder (if applicable): 2 Standard</p> <p>2 .</p>
--	---	---	---	---

<p>5th Option: Select the Casters (if applicable): H Black Hard Tread</p> <p>H .</p>	<p>6th Option: Select the Mesh (if applicable): SBM01 Carbon (Black)</p> <p>S B M 0 1 .</p>	<p>7th Option: Select the Upholstery (if applicable): QLB10 Black</p> <p>Q L B 1 0 .</p>
--	---	--

Example: LSTNO.BLK.W.L.2.H.SBM01.QLB10

Relate combines everything you want into a single collection of seating. A synchronous mechanism and a unique pivoting back provide exceptional ergonomics for more people at more tasks. Active adjustments allow you to control and customize your seating tension and support relative to any task. Replaceable high-wear parts encourage you to repair rather than replace your chairs. And, the full line of models makes coordinating office seating simple.

KEY FEATURES

Relate's Body Adaptive Control™ combines a weight-sensing synchronized tilt mechanism with a pivoting back, resulting in improved pressure distribution, superior back support, and movement for healthy sitting.

Synchronized Tilt

The synchronized tilt motion keeps the user's head level when reclining to improve mental focus and productivity, while reducing neck and eyestrain.

Pivoting Back

The position of the pivoting back aligns with the natural position of the spine. This alignment keeps the spine supported in its proper curvature, which increases comfort. The adaptive, pivoting motion provides continuous back support while encouraging movement. Movement while sitting replenishes the spinal discs with nutrients, which reduces fatigue and keeps discs healthy.

Quick Tension™ Lever

Features 5 settings to quickly adjust from low to high tension. Allows for frequent adjustment throughout the workday to provide custom support for different tasks.

Height-Adjustable Lumbar Support

Allows users to adjust lumbar support anywhere within a 4" range on upholstered and mesh work/conference chairs. Lumbar support on mesh chairs can be adjusted asynchronously.

Pneumatic Seat Height Adjustment

Regulates height of chair relative to the floor.

- Standard cylinder with 5" of travel accommodates average or tall users.
- Optional short cylinder with 3½" of travel keeps chair closer to the floor for shorter users, allowing all models to meet BIFMA G1-2002 solutions for VDT users.

Seat Depth Adjustment

Adjusts from front-to-back, within a 3" range, to accommodate different leg lengths.

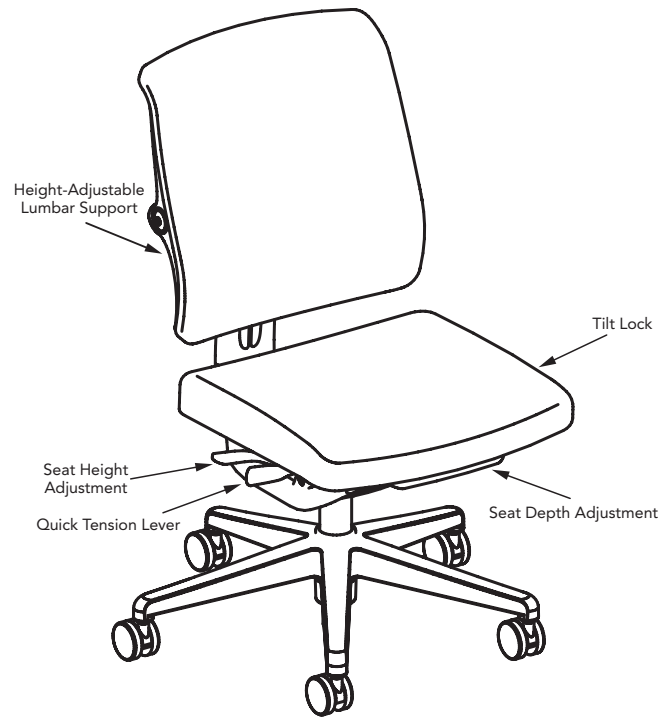

RL-UHA — Upholstered High-Back

Fully Adjustable Arms

Arms are fully adjustable in height, width, depth, and can pivot to provide optimal support. Pivot the front of the arm pads inward to move in closer to your desk and offer support while working.

DESIGN FEATURES

Relate seating is engineered to last a lifetime, simplify maintenance, and reduce costs.

Base/Casters

Base is composite five-star structure. Specific models are available in polished aluminum. Dual-wheel casters feature hard tread for carpeted floors or soft tread for smooth floors.

Link Mesh

Relate's Link Mesh is a leno weave with a polyester elastomeric and a polyester fill yarn. This construction provides responsive, conforming back support and an open, airy aesthetic. Link Mesh is 100% recyclable.

Materials

- All upholstery foams are **CFC-free**.
- All **COMs/COLs** must be approved for upholsterability or applicable fire code compliance prior to order entry. See COM ordering instructions on pages 6-8.
- **Flammability** code compliance of Allsteel textiles and seating is listed on pages 13-14. COM/COL manufacturers supply certificates of compliance for fabric-only tests such as CAL TB117-2013.

Relate meets the requirements set forth in ANSI/BIFMA X5.1-2011 and BIFMA G1-2013. Relate is warranted for multiple shifts and users up to 300 lbs.

Relate work chairs with adjustable arms ship knocked down.

OPTIONS — RELATE WORK/CONFERENCE:

Versions include High-Back models in mesh or upholstery with adjustable arms, fixed C arms, or without arms.

Back Type:

- M** Mesh (only available in High-Back)
- U** Upholstered

Overall Size:

- H** High-Back

Armrests:

- P** Fully Adjustable Arms
- A** Armless

Pneumatic Cylinder:

- 2** Standard, allows 5" of travel
- 3** Short, 3½" of travel to meet BIFMA G1-2002

Casters:

- 0** 2½" Black Dual-wheel Hard Tread for carpet
- 1** 2½" Black Dual-wheel Soft Tread for smooth surfaces (\$68 extra)

Lumbar:

- L** Height-Adjustable

Aluminum Option: (Aluminum models only — see pages 122-123)

- A1** Aluminum Base

Aluminum Finish:

- PAL** Polished Aluminum (Aluminum models only)

Frame Color:

- CBK** Charblack

Mesh Color: (for Mesh Backs Only)

Available on Charblack (**CBK**) frames

- LKM01** Carbon

Upholstery:

- See pages 13-14 for other upholstery selections.
- See pages 17-19 for colors and codes

NOTE: Mesh and upholstery work/conference chairs feature upholstered seats.

Seating — Work

- Features and adjustments on Relate models: Synchro-Tilt, Pivot Back, Seat Depth, and Pneumatic Adjustment.

GSA SIN 33721

(See page 150 for COM pricing on Grades 9-22)

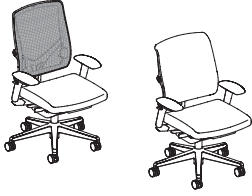
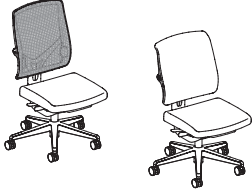
Armrest	Back Type	Model Number <i>Add options below</i>									Leather	
			1	2	3	4	5	6	7	8	1	2
Fully Adjustable Arms 	Mesh	RL-MHP	\$ 2223	\$ 2250	\$ 2273	\$ 2308	\$ 2339	\$ 2371	\$ 2405	\$ 2438	\$ 2943	\$ 4157
	High-Back											
	Upholstered	RL-UHP	\$ 2200	\$ 2245	\$ 2285	\$ 2341	\$ 2396	\$ 2457	\$ 2514	\$ 2571	\$ 3628	\$ 5530
	High-Back											
Armless 	Mesh	RL-MHA	\$ 1929	\$ 1956	\$ 1979	\$ 2014	\$ 2045	\$ 2077	\$ 2111	\$ 2144	\$ 2649	\$ 3863
	High-Back											
	Upholstered	RL-UHA	\$ 1905	\$ 1950	\$ 1990	\$ 2046	\$ 2101	\$ 2162	\$ 2219	\$ 2276	\$ 3333	\$ 5235
	High-Back											

NOTE: See pages 122-123 for polished aluminum Work/Conference models.

RELATE

Continued on next page ►

<p>How to specify — Select the Model Number from above.</p>	<p>1st Option: Select the Cylinder:</p> <p>2 Standard, allows 5" of travel 3 Short, allows 3½" of travel</p>	<p>2nd Option: Select the Casters:</p> <p>0 2½" Black Dual-Wheel Hard Tread for carpet 1 2½" Black Dual-Wheel Soft Tread for smooth surfaces (\$68 extra)</p>	<p>3rd Option: Select the Lumbar:</p> <p>L Height-Adjustable</p>
<p>RL - [] [] [] [] [] [] [] [] [] [] . [] [] .</p>			<p>[] .</p>

Example: RL-UHFC.2.0.L.CBK.BOX15

Model Number	COM Yardage			Overall			Seat				Armrests				Backrest			Ship Weight	Ship Weight Per Carton	Cubes	
	COL Sq. Feet	Height (Range)	Width	Depth	Height (Range)	Width	Depth (Range)	Pan Angle (Range)	Height (Range)	Width Between Armrests (Range)	Depth (Range)	Pivot Inwards	Pivot Outwards	Height (Range)	Width	Lumbar Height (Range)	Backrest/Seat Angle (Range)				
RL-MHP	1.3	11	39-44"	26"	24"	16-21" 14½-18"	19"	15-18"	3.5° to 8.5°	7½-11½"	14½-20½"	6¼-10¼"	25°	15°	23"	17½"	5¼-9¼"	94.5°-109°	47.0	—	11.0
RL-UHP	2.0	22	40¼-45¼"	26"	24"	16-21" 14½-18"	19"	15-18"	3.5° to 8.5°	7½-11½"	14½-20½"	6¼-10¼"	25°	15°	24"	17½"	5¼-9¼"	94.5°-109°	48.0	—	11.0
RL-MHA	1.3	11	39-44"	26"	24"	16-21" 14½-18"	19"	15-18"	3.5° to 8.5°	—	—	—	—	—	23"	17½"	5¼-9¼"	94.5°-109°	40.0	—	16.7
RL-UHA	2.0	22	40¼-45¼"	26"	24"	16-21" 14½-18"	19"	15-18"	3.5° to 8.5°	—	—	—	—	—	24"	17½"	5¼-9¼"	94.5°-109°	41.0	—	16.7

Dimensions are in accordance with BIFMA G1-2013 guidelines — see illustration of guidelines on page 45.



◀ Continued from previous page

<p>4th Option: Select the Frame Color: CBK Charblack</p>	<p>5th Option: Select the Mesh Color: For Mesh Back only. Available on Charblack (CBK) frames LKM01 Carbon</p>	<p>6th Option: Select the Upholstery: See pages 13-14 for selection. See pages 17-19 for colors and codes. See pages 6-8 for COM guidelines.</p>
---	---	---

Seating — Work

Relate®

- Features and adjustments on Relate models: Synchro-Tilt, Pivot Back, Seat Depth, Pneumatic Adjustment, and Polished Aluminum Base.

GSA SIN 33721

(See page 150 for COM pricing on Grades 9-22)

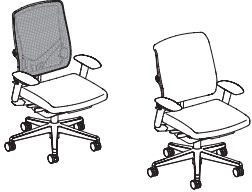
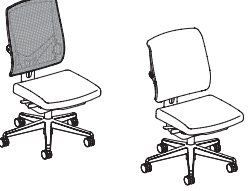
Armrest	Back Type	Model Number <i>Add options below</i>	1	2	3	4	5	6	7	8	Leather	
											1	2
	Mesh High-Back	RLA-MHP	\$ 2626	\$ 2653	\$ 2676	\$ 2711	\$ 2742	\$ 2774	\$ 2808	\$ 2841	\$ 3346	\$ 4560
	Upholstered High-Back	RLA-UHP	\$ 2603	\$ 2648	\$ 2688	\$ 2744	\$ 2799	\$ 2860	\$ 2917	\$ 2974	\$ 4031	\$ 5933
	Mesh High-Back	RLA-MHA	\$ 2331	\$ 2358	\$ 2381	\$ 2416	\$ 2447	\$ 2479	\$ 2513	\$ 2546	\$ 3051	\$ 4265
	Upholstered High-Back	RLA-UHA	\$ 2310	\$ 2355	\$ 2395	\$ 2451	\$ 2506	\$ 2567	\$ 2624	\$ 2681	\$ 3738	\$ 5640

RELATE

Continued on next page ►

<p>How to specify — Select the Model Number from above.</p>	<p>1st Option: Select the Cylinder:</p> <p>2 Standard, allows 5" of travel 3 Short, allows 3½" of travel</p>	<p>2nd Option: Select the Casters:</p> <p>0 2½" Black Dual-Wheel Hard Tread for carpet 1 2½" Black Dual-Wheel Soft Tread for smooth surfaces (\$68 extra)</p>	<p>3rd Option: Select the Lumbar:</p> <p>L Height-Adjustable</p>	<p>4th Option: Select the Aluminum Option:</p> <p>A1 Aluminum Base</p>
<p>R L - . .</p>		<p> .</p>	<p> .</p>	<p>A .</p>

Example: RLA-UHPFC.2.0.N.A1.PAL.CBK.BOX15

	COM Yardage			Overall			Seat				Armrests				Backrest			Ship Weight	Ship Weight Per Carton	Cubes	
	COL Sq. Feet	Height (Range)	Width	Depth	Height (Range)	Width	Depth (Range)	Pan Angle (Range)	Height (Range)	Width Between Armrests (Range)	Depth (Range)	Pivot Inwards	Pivot Outwards	Height (Range)	Width	Lumbar Height (Range)	Backrest Seat Angle (Range)				
RLA-MHP	1.3	11	39-44"	26"	24"	17½-22½" 14½-18"	19"	15-18"	3.5° to 8.5°	7½-11½"	14½-20½"	6¼-10¼"	25°	15°	23"	17½"	5¼-9¼"	94.5°-109°	47.0	—	11.0
RLA-UHP	2.0	22	40¼-45¼"	26"	24"	17½-22½" 14½-18"	19"	15-18"	3.5° to 8.5°	7½-11½"	14½-20½"	6¼-10¼"	25°	15°	24¼"	17½"	5¼-9¼"	94.5°-109°	48.0	—	11.0
RLA-MHA	1.3	11	39-44"	26"	24"	17½-22½" 14½-18"	19"	15-18"	3.5° to 8.5°	—	—	—	—	—	23"	17½"	5¼-9¼"	94.5°-109°	40.0	—	16.7
RLA-UHA	2.0	22	40¼-45¼"	26"	24"	17½-22½" 14½-18"	19"	15-18"	3.5° to 8.5°	—	—	—	—	—	24¼"	17½"	5¼-9¼"	94.5°-109°	41.0	—	16.7

Dimensions are in accordance with BIFMA G1-2002 guidelines — see illustration of guidelines on page 45.



◀ Continued from previous page

<p>5th Option: Select the Aluminum Finish: PAL Polished Aluminum</p>	<p>6th Option: Select the Frame Color: CBK Charblack</p>	<p>7th Option: Select the Mesh Color: For Mesh Back only. Available on Charblack (CBK) frames LKM01 Carbon</p>	<p>8th Option: Select the Upholstery: See pages 13-14 for selection. See pages 17-19 for colors and codes. See pages 6-8 for COM guidelines.</p>
<p>P A L .</p>	<p> </p>	<p> .</p>	<p> </p>

Relate offers a full line of seating in complementary finishes making it simple to coordinate seating for the entire office. The Relate work stool is the perfect solution for anyplace where work happens at a standing height position. Relate work stools feature all of the same intuitive, ergonomic adjustments as the Relate work/conference chair.

KEY FEATURES

Relate's Body Adaptive Control™ combines a weight-sensing synchronized tilt mechanism with a pivoting back, resulting in improved pressure distribution, superior back support, and movement for healthy sitting.

Synchronized Tilt

The synchronized tilt motion keeps the user's head level when reclining to improve mental focus and productivity, while reducing neck and eyestrain.

Pivoting Back

The position of the pivoting back aligns with the natural position of the spine. This alignment keeps the spine supported in its proper curvature, which increases comfort. The adaptive, pivoting motion provides continuous back support while encouraging movement. Movement while sitting replenishes the spinal discs with nutrients, which reduces fatigue and keeps discs healthy.

Quick Tension™ Lever

Features 5 settings to quickly adjust from low to high tension. Allows for frequent adjustment throughout the workday to provide custom support for different tasks.

Height-Adjustable Lumbar Support

Allows users to adjust lumbar support anywhere within a 4" range on upholstered and mesh work stools. Lumbar support on mesh work stools can be adjusted asynchronously.

Pneumatic Seat Height Adjustment

Regulates height of stool relative to the floor. Includes extended range height pneumatic cylinder with 10" of vertical travel.

Seat Depth Adjustment

Adjusts from front-to-back, within a 3" range, to accommodate different leg lengths.

Height-Adjustable Footring

Travels 8" to ensure users have comfortable support of their feet and legs. The footring has a 20" diameter.

Fully Adjustable Arms

Arms are fully adjustable in height, width, depth, and can pivot to provide optimal support. Pivot the front of the arm pads inward to move in closer to your desk and offer support while working.

DESIGN FEATURES

Relate seating is engineered to last a lifetime, simplify maintenance, and reduce costs.

Base/Casters

Base is composite five-star structure. Dual-wheel casters feature hard tread for carpeted floors or soft tread for smooth floors.

Link Mesh

Relate's Link Mesh is a leno weave with a polyester elastomeric and a polyester fill yarn. This construction provides responsive, conforming back support and an open, airy aesthetic. Link Mesh is 100% recyclable.

Materials

- All upholstery foams are **CFC-free**.
- All **COMs/COLs** must be approved for upholsterability or applicable fire code compliance prior to order entry. See COM ordering instructions on pages 6-8.
- **Flammability** code compliance of Allsteel textiles and seating is listed on pages 13-14. COM/COL manufacturers supply certificates of compliance for fabric-only tests such as CAL TB117-2013.

Relate meets the requirements set forth in ANSI/BIFMA X5.1-2011 and BIFMA G1-2013. Relate Work Stools are warranted for multiple shifts and users up to 300 lbs.

OPTIONS — RELATE WORK STOOL:

Versions include High-Back models in mesh or upholstery with adjustable arms, fixed C arms, or without arms.

Back Type:

M Mesh

Overall Size:

H High-Back

Armrests:

P Fully Adjustable Arms

A Armless

Pneumatic Cylinder:

4 Extended Range, allows 10" of travel

Casters/Glides:

0 2½" Black Dual-Wheel Hard Tread Casters for carpet

1 2½" Black Dual-Wheel Soft Tread Casters for smooth surfaces (\$68 extra)

2 Glides

Lumbar:

L Height-adjustable

Frame Color:

CBK Charblack

Mesh Color: (for Mesh Backs Only)

Available on Charblack (CBK) frames

LKM01 Carbon

Upholstery:

See pages 13-14 for other upholstery selections.

See pages 17-19 for colors and codes

NOTE: Mesh and upholstery work stools feature upholstered seats.



Seating — Work Stool

Relate®

- Features and adjustments on Relate Stools: Synchro-Tilt, Pivot Back, Seat Depth, and Pneumatic Adjustment.

GSA SIN 33721

(See page 150 for COM pricing on Grades 9-22)

Armrest	Back Type	Model Number <i>Add options below</i>	1	2	3	4	5	6	7	8	Leather	
											1	2
Fully Adjustable Arms 	Mesh	RLS-MHP High-Back	\$ 2955	\$ 2982	\$ 3005	\$ 3040	\$ 3071	\$ 3103	\$ 3137	\$ 3170	\$ 3675	\$ 4889
Armless 	Mesh	RLS-MHA High-Back	\$ 2661	\$ 2688	\$ 2711	\$ 2746	\$ 2777	\$ 2809	\$ 2843	\$ 2876	\$ 3381	\$ 4595

RELATE

Continued on next page ►

<p>How to specify — Select the Model Number from above.</p>	<p>1st Option: Select the Cylinder (if applicable):</p> <p>4 Extended range, allows 10" of travel</p>	<p>2nd Option: Select the Casters/Glides:</p> <p>0 2½" Black Dual-Wheel Hard Tread Casters for carpet</p> <p>1 2½" Black Dual-Wheel Soft Tread Casters for smooth surfaces (\$68 extra)</p> <p>2 Glides</p>	<p>3rd Option: Select the Lumbar:</p> <p>L Height-Adjustable</p>
<p>RLS- . 4 .</p>			

Example:

Model Number	COM Yardage		Overall				Seat			Armrests				Backrest			Ship Weight	Ship Weight Per Carton	Cubes		
	COL Sq. Feet	Height (Range)	Width	Depth	Height (Range)	Width	Depth (Range)	Pan Angle (Range)	Height (Range)	Width Between Armrests (Range)	Depth (Range)	Pivot Inwards	Pivot Outwards	Height (Range)	Width	Lumbar Height (Range)				Backrest Seat Angle (Range)	
RLS-MHP	1.3	11	46-56"	27½"	25½"	24-34"	19"	15-18"	3.5° to 8.5°	7½-11½"	14½-20¼"	6¼-10¼"	25°	15°	23"	17½"	5¼-9¼"	94.5°-109°	57.0	—	12.6
RLS-MHA	1.3	11	46-56"	27½"	25½"	24-34"	19"	15-18"	3.5° to 8.5°	—	—	—	—	—	23"	17½"	5¼-9¼"	94.5°-109°	50.0	—	12.6

Dimensions are in accordance with BIFMA G1-2013 guidelines — see illustration of guidelines on page 45.



◀ Continued from previous page

<p><i>4th Option:</i> Select the Frame Color: CBK Charblack</p>	<p><i>5th Option:</i> Select the Mesh Color: For Mesh Back only. Available on Charblack (CBK) frames LKM01 Carbon</p>	<p><i>6th Option:</i> Select the Upholstery: See pages 13-14 for selection. See pages 17-19 for colors and codes. See pages 6-8 for COM guidelines.</p>
--	--	--

Relate multi-purpose side chairs provide an ideal solution for busy work areas such as training rooms, gathering areas, informal conferencing, cafés, and more. With a stackable design and pivoting back, Relate side chairs provide the perfect combination of versatility and unexpected comfort.

MODELS AND OPTIONS

Relate offers side chair models with **back types** in mesh, upholstery, and wood in three frame colors.

Side chairs feature **arm and armless models** with casters or glides.

Glides are available in nylon, nickel-plated, or felt options. Nylon glides are recommended for hard surfaces, commercial carpet, and damp environments. Nickel-plated glides are recommended for carpet. Felt glides are recommended for wood, tile, or high-shine floor surfaces.

Multi-surface casters are also available.

Chairs ship up to two per carton to minimize waste.

CONSTRUCTION

Steel frames and structural moldings create a durable design that performs in a variety of environments.

Seat and back upholstery are easily field replaceable allowing users to extend the lifecycle of the chairs.

Multi-purpose side chairs **stack up to 4-high** on the floor.

Mesh chairs feature Link™ Mesh. **Link Mesh** is a leno weave with a polyester elastomeric and a polyester fill yarn. This construction provides responsive, conforming back support and an open, airy aesthetic. Link Mesh is 100% recyclable.

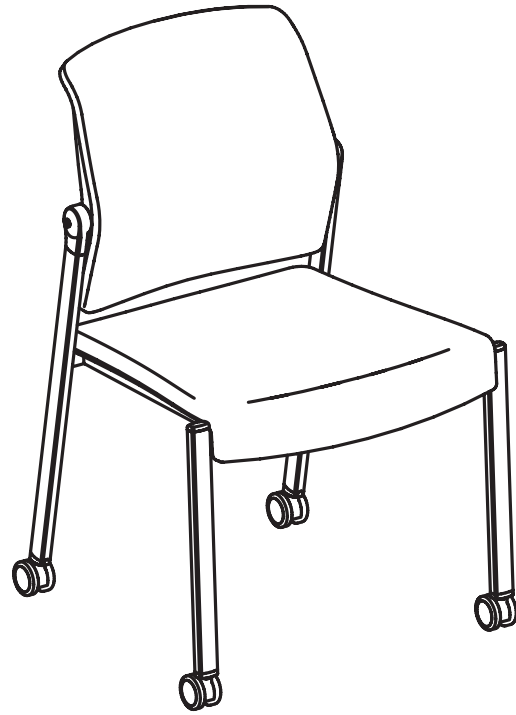

RLM-UUCA — Upholstered Back and Upholstered Seat

UPHOLSTERY AND CONTOURING

Relate multi-purpose side chairs feature a pivoting back that provides unexpected comfort in any application. The **pivoting back** provides support while encouraging movement that makes for healthy sitting. The **backrest** features a contoured lumbar support to help relieve stress on the back. Added movement and support allow the Relate multi-purpose side chair to go from project conference rooms to teaming areas to training rooms with ease.

The upholstered seat features a generous 2" of high-resiliency molded foam padding for comfort and long-term support.

All upholstery foams are **CFC-free**.

All **COMs/COLs** must be approved for upholsterability or applicable fire code compliance prior to order entry. See COM ordering instructions on pages 6-8.

Flammability code compliance of Allsteel textiles and seating is listed on pages 13-14. COM/COL manufacturers supply certificates of compliance for fabric-only tests such as CAL TB117-2013.

Relate meets the requirements set forth in ANSI/BIFMA X5.1-2011. Relate side chairs are warranted for users up to 300 lbs.

OPTIONS — RELATE MULTI-PURPOSE SIDE:

Versions include arm and armless models with glides or casters in an upholstered seat and mesh, upholstered, or wood back.

Back Type:

- M** Mesh
- U** Upholstered

Seat Type:

- U** Upholstered

Frame Type:

- C** Casters
- G** Glides

Arm Option:

- O** Arms
- A** Armless

Glides/Casters:

- 0** Nylon Glides for hard surfaces and commercial carpet
- 1** Nickel-plated Glides for carpet (\$19 extra)
- 2** Felt Glides for wood, tile, or high sheen surfaces. (\$19 extra)
- 3** Multi-surface Casters

Frame Color: (mesh frame black for all but Titanium)

- CBK** Charblack
- P8T** Titanium
- P8X** Solar Black
- PR6** Silver (arms are Charblack)

Mesh Color: (for Mesh Backs Only)

Available on Charblack (CBK) mesh frames (CBK, PR6, and P8X frame color choices)

- LKM01** Carbon

Available on Titanium (P8T) mesh frames (P8T frame color choice)





- LKM01** Carbon
- CM23** Platinum

Select the Upholstery: (for upholstered seats or upholstered backs)

See pages 13-14 for selections.

See pages 17-19 for colors and codes.

(See page 150 for COM pricing on Grades 9-22)

Overall Size Armrest	Adjustments and Features	Back Type	Model Number <i>Add options below</i>	1	2	3	4	5	6	7	8	Leather	
											1	2	
GLIDES Arms 	Pivot Back	Mesh	RLM-MUGO	\$ 1034	\$ 1066	\$ 1099	\$ 1140	\$ 1181	\$ 1221	\$ 1262	\$ 1301	\$ 1742	\$ 2939
		Upholstered*	RLM-UUGO	\$ 1023	\$ 1072	\$ 1117	\$ 1168	\$ 1225	\$ 1278	\$ 1330	\$ 1389	\$ 2594	\$ 4060
Armless 	Pivot Back	Mesh	RLM-MUGA	\$ 968	\$ 1000	\$ 1033	\$ 1074	\$ 1115	\$ 1155	\$ 1196	\$ 1235	\$ 1676	\$ 2873
		Upholstered*	RLM-UUGA	\$ 957	\$ 1006	\$ 1051	\$ 1104	\$ 1160	\$ 1214	\$ 1266	\$ 1325	\$ 2540	\$ 4017
		Wood	RLM-WUGA	\$ 1011	\$ 1043	\$ 1076	\$ 1117	\$ 1158	\$ 1198	\$ 1239	\$ 1278	\$ 1719	\$ 2916
CASTERS Arms 	Pivot Back	Mesh	RLM-MUCO	\$ 1126	\$ 1158	\$ 1191	\$ 1232	\$ 1273	\$ 1313	\$ 1354	\$ 1393	\$ 1834	\$ 3031
		Upholstered*	RLM-UUCO	\$ 1115	\$ 1163	\$ 1207	\$ 1259	\$ 1313	\$ 1369	\$ 1420	\$ 1477	\$ 2676	\$ 4129
Armless 	Pivot Back	Mesh	RLM-MUCA	\$ 1058	\$ 1090	\$ 1123	\$ 1164	\$ 1205	\$ 1245	\$ 1286	\$ 1325	\$ 1766	\$ 2963
		Upholstered*	RLM-UUCA	\$ 1048	\$ 1097	\$ 1140	\$ 1193	\$ 1249	\$ 1303	\$ 1354	\$ 1413	\$ 2617	\$ 4079

NOTE: Relate side chairs ship two per carton to minimize waste. Model numbers and prices are per chair.

Continued on next page ►

<p>How to specify — Select the Model Number from above.</p>	<p>1st Option: Select the Glides/Casters:</p> <ul style="list-style-type: none"> 0 Nylon Glides 1 Nickel-plated Glides (\$19 extra) 2 Felt Glides (\$19 extra) 3 Multi-surface Casters 	<p>2nd Option: Select the Frame Color*:</p> <ul style="list-style-type: none"> CBK Charblack P8T Titanium (wood and upholstered back models are not available with Titanium frame color) PR6 Silver (arms, mesh carrier, and upholstered outer back are Charblack) P8X Solar Black
<p>R L M - U . .</p>		<p> </p>

Examples: RLM-MUGO.0.CBKLM01.BOX15 RLM-PUCA.3.CBK.BOX15

RELATE

Model Number	Overall				Seat			Armrests				Backrest				Ship Weight	Ship Weight Per Carton	Cubes		
	COM Yachage	COL Sp. Feet	Height (Range)	Width	Depth	Height (Range)	Width	Depth (Range)	Pan Angle (Range)	Height (Range)	Width Between Armrests (Range)	Depth (Range)	Arm Height to the Floor	Height (Range)	Width				Lumbar Height (Range)	Backrest/Seat Angle (Range)
RLM-MUGO	1.0	11.5	33½"	24½"	21½"	18½"	17½"	16"	7°	9¼"	20½"	15"	26¼"	18½"	16¼"	9¼"	95°-100°	24.0	-	13.2
RLM-UUGO	1.8	19.5	33½"	24½"	21½"	18½"	17½"	16¼"	7°	9¼"	20½"	15"	26¼"	18½"	16¼"	8"	95°-100°	24.0	-	13.2
RLM-MUGA	1.0	11.5	33½"	22½"	21½"	18½"	17½"	16"	7°	-	-	-	-	18½"	16¼"	9¼"	95°-100°	21.0	-	13.2
RLM-UUGA	1.8	19.5	33½"	22½"	21½"	18½"	17½"	16¼"	7°	-	-	-	-	18½"	16¼"	8"	95°-100°	21.0	-	13.2
RLM-WUGA	1.0	11.5	33"	22½"	21½"	18½"	17½"	17"	7°	-	-	-	-	17½"	16½"	8"	95°-100°	22.0	-	13.2
RLM-MUCO	1.0	11.5	33½"	24½"	21½"	18½"	17½"	16"	7°	9¼"	20½"	15"	26¼"	18½"	16¼"	9¼"	95°-100°	24.0	-	13.2
RLM-UUCO	1.8	19.5	33½"	24½"	21½"	18½"	17½"	16¼"	7°	9¼"	20½"	15"	26¼"	18½"	16¼"	8"	95°-100°	24.0	-	13.2
RLM-MUCA	1.0	11.5	33½"	22½"	21½"	18½"	17½"	16"	7°	-	-	-	-	18½"	16¼"	9¼"	95°-100°	21.0	-	13.2
RLM-UUCA	1.8	19.5	33½"	22½"	21½"	18½"	17½"	16¼"	7°	-	-	-	-	18½"	16¼"	8"	95°-100°	21.0	-	13.2



◀ Continued from previous page

<p>3rd Option: Select the Mesh Color: For Mesh Back only.</p> <p>Available on Charblack CBK and Silver PR6 frames</p> <p>LKM01 Carbon</p> <p>Available on Titanium P8T frames</p> <p>LKM01 Carbon CM23 Platinum</p>	<p>4th Option: Select the Upholstery:</p> <p>See pages 13-14 for selection. See pages 17-19 for colors and codes. See pages 6-8 for COM guidelines.</p>
---	--

Relate 4-Leg Stools are the perfect solution for any application where people prefer a standing height position such as cafés, standing height workstations, touchdown areas, and coffee bars. Similar to the side chair, Relate 4-Leg Stools feature a pivoting back for exceptional comfort and support.

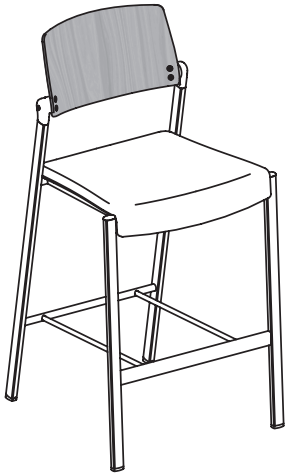

**RLC-WUGA —
Wood Back**

MODELS AND OPTIONS

Relate 4-Leg Stools are available with mesh, upholstered or wood backs. Four-legged stools feature arm and armless models with glides.

Glides are available in nylon, nickel-plated, or felt options. Nylon glides are recommended for hard surfaces, commercial carpet, and damp environments. Nickel-plated glides are recommended for carpet. Felt glides are recommended for wood, tile, or high-sheen floor surfaces.

CONSTRUCTION

Steel frames and structural moldings create a durable design that performs in a variety of environments.

Seat upholstery is easily field replaceable allowing users to extend the lifecycle of the chairs.

UPHOLSTERY AND CONTOURING

Relate 4-Leg Stools feature a pivoting back that provides unexpected comfort in any application. The **pivoting back** provides support while encouraging movement that makes for healthy sitting. The **backrest** features a contoured lumbar support to help relieve stress on the back.

The upholstered seat features a generous 2" of high-resiliency molded foam padding for comfort and long-term support.

All upholstery foams are **CFC-free**.

All **COMs/COLs** must be approved for upholsterability or applicable fire code compliance prior to order entry. See COM ordering instructions on pages 6-8.

Flammability code compliance of Allsteel textiles and seating is listed on pages 13-14. COM/COL manufacturers supply certificates of compliance for fabric-only tests such as CAL TB117-2013.

Relate meets the requirements set forth in ANSI/BIFMA X5.1-2011. Relate four-legged stools are warranted for users up to 300 lbs.

OPTIONS — 4-LEG STOOL:

4-Leg Stools are available in arm or armless models with glides, an upholstered seat and wood back.

Back Type:

- M** Mesh
- U** Upholstered
- W** Wood (Wood, as a natural material, is subject to nature's quality control with variations in grain pattern and tone.)

Seat Type:

- U** Upholstered

Frame Type:

- G** Glides

Arm Option:

- O** Arms
- A** Armless

Glides:

- 0** Nylon Glides for hard surfaces and commercial carpet
- 1** Nickel-plated Glides for carpet (\$19 extra)
- 2** Felt Glides for wood, tile, or high sheen surfaces. (\$19 extra)

Frame Color: (mesh frame black for all but Titanium)

- CBK** Charblack
- P8T** Titanium
- P8X** Solar Black
- PR6** Silver (arms are Charblack)

Mesh Color (for Mesh Backs only):

Available on Charblack (**CBK**) mesh frames (**CBK, PR6, and P8X** frame color choices)

- LKM01** Carbon

Available on Titanium (**P8T**) mesh frames (**P8T** frame color choice)

- LKM01** Carbon
- CM23** Platinum

Wood Finishes (for Wood Backs only):

- NE800** Natural Maple
- NC777** Burnished Cherry
- NC701** Light Cherry

Select the Seat Upholstery:

- See pages 13-14 for selections.
- See pages 17-19 for colors and codes.

Seek is a multi-purpose chair designed for today's ever-changing corporate environments that require durability, versatility, and beauty. Its light-weight mobile design is ideal for multi-purpose settings such as adjunct teaming areas, conference rooms, classrooms, training rooms, and cafés.

The idea has always been to provide seating that one can sit in...not on. Seek achieves this with a deceptively simple design that conforms to the shape and movement of each user's body. Its pivoting back allows for natural shifts in posture while intuitively distributing lumbar support. The contoured seat reduces pressure points and evenly distributes weight for long-term comfort. So sit back, relax, and let Seek do all the work.

MODELS AND OPTIONS

With Seek, extended periods of sitting are refreshingly comfortable. Designed to move with the body and minimize pressure points, Seek conforms to each user's body movement, so no matter how they sit — or how long they stay — they stay comfortable.

Weight-assisted pivot back technology intuitively provides balance and lumbar support for ergonomic recline.

Contoured seat design distributes weight evenly, stabilizing the sitting bones during forward and reclined comfort. Universal fitting, Seek comfortably accommodates 95% of users.

Arm and armless models available. The curved shape of the arms accommodates differences in elbow height. The downward curve helps when approaching worksurfaces.

Casters or glides are available. Glide options include nylon, nickel-plated, or felt. The versatile multi-surface casters are designed for use on hard or soft surfaces.

Seek offers the ability to stack, to nest, and to nest the stacks for optimum space efficiency. The seat folds up so multiple chairs nest together like grocery carts. Four nested chairs can move or store together in a discrete 37-inches of space. Each additional nested chair adds 5 $\frac{1}{8}$ " of depth. Multiple chairs can stack up to four high in a space of 53"H x 28"W x 22"D. Each additional stack of nested chairs adds 15" of depth.

A Seek stack height of 4 chairs is recommended for storage density that allows the stacks to nest together. A maximum stack height of 6 chairs should not be exceeded when transporting the stacks of chairs.

Chairs ship two per carton to minimize waste. Model numbers and prices are per chair.

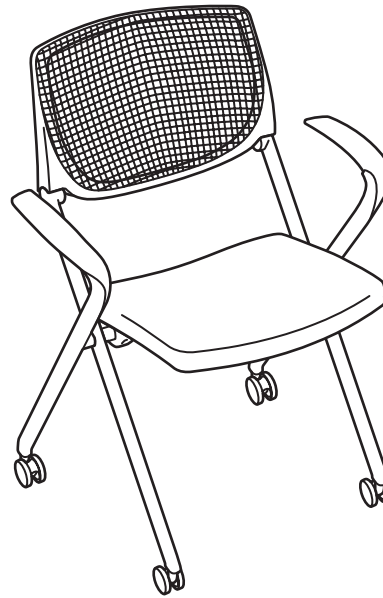

K-MUCO

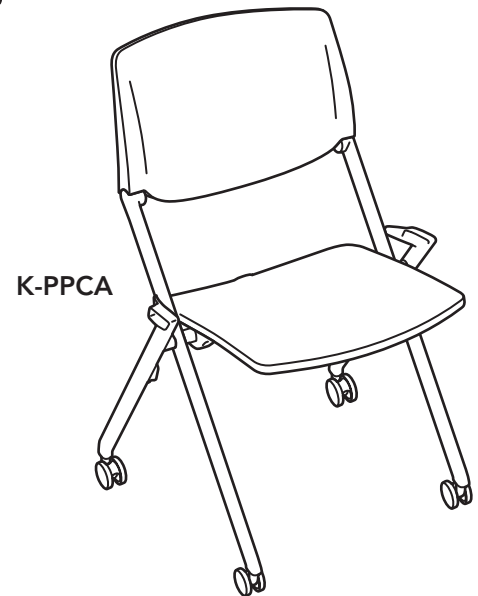

K-PPCA

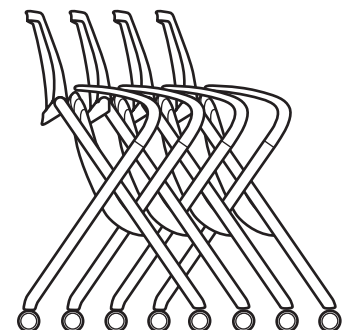
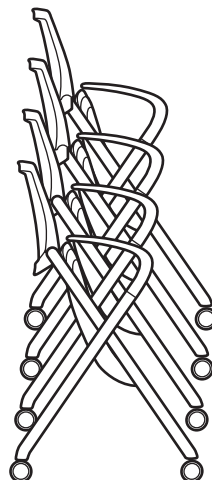

CONSTRUCTION

The solid construction meets or exceeds industry standards for performance. Seek’s flexible molded-polymer backrest facilitates heat-reducing airflow. Optional mesh back lets light and air through for added comfort.

Seek’s polymer shells are made from recyclable color-matched polymers with UV resistance to preserve colorfastness and ensure long-term durability. Allsteel paint finishes (for frames) are formulated for optimum hardness and chip resistance.

Seek meets the requirements set forth in ANSI/BIFMA X5.1-2011. Seek is level®2 certified. Seek is warranted for multiple shifts and users up to 300 lbs. Its lightweight construction makes it easy to move.

Allsteel fabrics and foam meet requirements for CAL TB117-2013. COM/COL manufacturers supply certificates of compliance for fabric-only tests such as CAL TB117-2013.

OPTIONS — SEEK:

Backrest Style:

- M** Mesh Back (Dusk Mesh only)
- P** Polymer Back

Seat Style:

- U** Upholstered Seat
- P** Polymer Seat

Casters/Glides:

- C** Casters
- G** Glides

Armrests:

- O** Arm Chair
- A** Armless

Frame Finish:

- P8X** Solar Black
- P8T** Titanium
- B** Black
- S** Silver

Fire Code:

- NO** Standard Upholstery, No Fire Code

Polymer Color:

- BLK** Black (formerly Onyx)
- BU** Surf
- BW** Brownstone
- GN** Sprout*
- GY** Summit
- RD** Cayenne*
- RG** Tangelo*
- WT** White (formerly Frost)

*Only available for polymer back models

Type of Glides/Casters:

- 0** Nylon Glides
- 1** Nickel-plated Glides (\$19 extra)
- 2** Felt Glides (\$19 extra)
- 3** Multi-surface Casters

Upholstery:





See pages 13-14 for Selections and pages 17-19 for Color Codes.

Seat (polymer seat models):

- POLYST** Polymer Seat

FLOOR COVERING	TYPE OF GLIDE			
	Polycarbonate/Nylon	Felt	Steel	Rubber
Carpet	Best	Not Recommended	Good	Not Recommended
Polished Concrete	Best	Good	Not Recommended	Not Recommended
Hardwood	Not Recommended	Best	Not Recommended	Good
Vinyl (Includes LVT)	Best	Better	Good	Good
VCT	Best	Good	Not Recommended	Good
Tile (Porcelain/Ceramic)	Best	Good	Not Recommended	Good
Attention	Particles can become lodged in nylon and mar floor surface.	Particles can become lodged in felt and mar floor surface.	Cleaning chemicals and water can cause rusting.	Resists moving/sliding. Could lead to chairs tipping back.

(See page 150 for COM pricing on Grades 9-22)

Backrest Style Arm Style	Seat Construction	Glides or Casters	Model Number <i>Add options below</i>	1	2	3	4	5	6	7	8	Leather		
											L1	L2		
Mesh Back Arms 	Upholstered Seat	Glides	K-MUGO	\$ 1272	\$ 1296	\$ 1312	\$ 1336	\$ 1358	\$ 1381	\$ 1406	\$ 1428	\$ 1500	\$ 1622	
		Casters	K-MUCO	\$ 1295	\$ 1319	\$ 1335	\$ 1359	\$ 1381	\$ 1404	\$ 1429	\$ 1451	\$ 1523	\$ 1645	
	Polymer Seat	Glides	K-MPGO	\$ 1165	—	—	—	—	—	—	—	—	—	—
		Casters	K-MPCO	\$ 1189	—	—	—	—	—	—	—	—	—	—
Mesh Back Armless 	Upholstered Seat	Glides	K-MUGA	\$ 1215	\$ 1239	\$ 1255	\$ 1279	\$ 1301	\$ 1324	\$ 1349	\$ 1371	\$ 1443	\$ 1565	
		Casters	K-MUCA	\$ 1241	\$ 1265	\$ 1281	\$ 1305	\$ 1327	\$ 1350	\$ 1375	\$ 1397	\$ 1469	\$ 1591	
	Polymer Seat	Glides	K-MPGA	\$ 1109	—	—	—	—	—	—	—	—	—	—
		Casters	K-MPCA	\$ 1109	—	—	—	—	—	—	—	—	—	—
Polymer Back Arms 	Upholstered Seat	Glides	K-PUGO	\$ 1055	\$ 1079	\$ 1095	\$ 1119	\$ 1141	\$ 1164	\$ 1189	\$ 1211	\$ 1283	\$ 1405	
		Casters	K-PUCO	\$ 1079	\$ 1103	\$ 1119	\$ 1143	\$ 1165	\$ 1188	\$ 1213	\$ 1235	\$ 1307	\$ 1429	
	Polymer Seat	Glides	K-PPGO	\$ 952	—	—	—	—	—	—	—	—	—	—
		Casters	K-PPCO	\$ 975	—	—	—	—	—	—	—	—	—	—
Polymer Back Armless 	Upholstered Seat	Glides	K-PUGA	\$ 1001	\$ 1025	\$ 1041	\$ 1065	\$ 1087	\$ 1110	\$ 1135	\$ 1157	\$ 1229	\$ 1351	
		Casters	K-PUCA	\$ 1023	\$ 1047	\$ 1063	\$ 1087	\$ 1109	\$ 1132	\$ 1157	\$ 1179	\$ 1251	\$ 1373	
	Polymer Seat	Glides	K-PPGA	\$ 897	—	—	—	—	—	—	—	—	—	—
		Casters	K-PPCA	\$ 922	—	—	—	—	—	—	—	—	—	—

SEEK

Continued on next page ►

<p>How to specify — Select the Model Number from above.</p> <p>K - [] [] [] [] []</p>	<p>1st Option: Select the Frame Finish:</p> <p>B for Black frame finish S for Silver frame finish P8X Solar Black P8T Titanium</p>	<p>2nd Option: Select the Fire Code:</p> <p>NO</p>	<p>3rd Option: Select the Polymer Color:</p> <p>BLK Black (formerly CB – Onyx) BU Surf BW Brownstone GN Sprout* GY Summit RD Cayenne* RG Tangelo* WT White (formerly Frost)</p> <p><i>*Only available for Polymer Back models.</i></p>
--	---	--	--

Examples: K-MUGOBNO.CB.1.BOX15 K-PUCASNO.BU.3.DOD10

K-MPGOBNO.CB.0.POLYST

Model Number	COM Yandage		COL Sp. Feet Seat		COL Sp. Feet Back		COL Sp. Feet Arms		Overall			Seat			Armrests			Backrest			Ship Weight per Carton	Cubes
	COL Sp. Feet Seat	COL Sp. Feet Back	COL Sp. Feet Arms	Height (Range)	Width	Depth	Height	Width	Depth	Pan Angle	Height	Width	Depth	Pivot Inwards	Pivot Outwards	Height	Width	Lumbar Height (Initial)	Backrest/Seat Angle (Range)			
K-MUGO	0.7	4	—	—	35½"	28"	22"	19"	18"	17¼"	4°	8½"	23"	12¼"	—	—	19"	19½"	9½"	95°-103°	41	19.0 (2 per carton)
K-MUCO	0.7	4	—	—	35½"	28"	22"	19"	18"	17¼"	4°	8½"	23"	12¼"	—	—	19"	19½"	9½"	95°-103°	41.6	19.0 (2 per carton)
K-MPGO	—	—	—	—	35½"	28"	22"	18½"	17¾"	17¼"	6°	9½"	23"	12¼"	—	—	19½"	19½"	8½"	92°-100°	39.4	19.0 (2 per carton)
K-MPCO	—	—	—	—	35½"	28"	22"	18½"	17¾"	17¼"	6°	9½"	23"	12¼"	—	—	19½"	19½"	8½"	92°-100°	40	19.0 (2 per carton)
K-MUGA	0.7	4	—	—	35½"	23¾"	22"	19"	18"	17¼"	4°	—	—	—	—	19"	19½"	9½"	95°-103°	37.4	19.0 (2 per carton)	
K-MUCA	0.7	4	—	—	35½"	23¾"	22"	19"	18"	17¼"	4°	—	—	—	—	19"	19½"	9½"	95°-103°	38	19.0 (2 per carton)	
K-MPGA	—	—	—	—	35½"	23¾"	22"	18½"	17¾"	17¼"	6°	—	—	—	—	19½"	19½"	8½"	92°-100°	35.8	19.0 (2 per carton)	
K-MPCA	—	—	—	—	35½"	23¾"	22"	18½"	17¾"	17¼"	6°	—	—	—	—	19½"	19½"	8½"	92°-100°	36.4	19.0 (2 per carton)	
K-PUGO	0.7	4	—	—	35½"	28"	22"	19"	18"	17¼"	4°	8½"	23"	12¼"	—	—	19"	19½"	9½"	95°-103°	41	19.0 (2 per carton)
K-PUCO	0.7	4	—	—	35½"	28"	22"	19"	18"	17¼"	4°	8½"	23"	12¼"	—	—	19"	19½"	9½"	95°-103°	41.6	19.0 (2 per carton)
K-PPGO	—	—	—	—	35½"	28"	22"	18½"	17¾"	17¼"	6°	9½"	23"	12¼"	—	—	19½"	19½"	8½"	92°-100°	37.4	19.0 (2 per carton)
K-PPCO	—	—	—	—	35½"	28"	22"	18½"	17¾"	17¼"	6°	9½"	23"	12¼"	—	—	19½"	19½"	8½"	92°-100°	38	19.0 (2 per carton)
K-PUGA	0.7	4	—	—	35½"	23¾"	22"	19"	18"	17¼"	4°	—	—	—	—	19"	19½"	9½"	95°-103°	39.4	19.0 (2 per carton)	
K-PPCA	0.7	4	—	—	35½"	23¾"	22"	19"	18"	17¼"	4°	—	—	—	—	19"	19½"	9½"	95°-103°	40	19.0 (2 per carton)	
K-PPGA	—	—	—	—	35½"	23¾"	22"	18½"	17¾"	17¼"	6°	—	—	—	—	19½"	19½"	8½"	92°-100°	35.8	19.0 (2 per carton)	
K-PPCA	—	—	—	—	35½"	23¾"	22"	18½"	17¾"	17¼"	6°	—	—	—	—	19½"	19½"	8½"	92°-100°	36.4	19.0 (2 per carton)	





Seek chairs ship in cartons containing 2 chairs. Model numbers and prices are per chair.

◀ Continued from previous page

<p>4th Option: Select the Glide/Casters:</p> <ul style="list-style-type: none"> 0 Nylon Glides 1 Nickel-plated Glides (\$19 extra) 2 Felt Glides (\$19 extra) 3 Multi-surface Casters 	<p>5th Option: Select the Upholstery (if applicable):</p> <p>See pages 13-14 for selection.</p> <p>See pages 17-19 for colors and codes.</p> <p>See pages 6-8 for COM guidelines.</p>	<p>5th Option: Select the Seat Option (if applicable):</p> <p>POLYST Polymer Seat</p>
POLYST		

Svelte is a modern, multi-functional office chair that brings refined, yet affordable, sophistication across a variety of applications. Sophistication shouldn't have to be expensive, and quality can be affordable. Svelte gracefully alleviates the disparity between low-cost and luxury with an elegant design that possesses an aesthetic as slender as the stack of cash to afford it. Combine that with its ability to consistently perform across almost any office setting, and it only adds to its value. Svelte meets the requirements set forth in ANSI/BIFMA X5.1-2013. Svelte is warranted for multiple shifts and users up to 300 lbs.

(See page 150 for COM pricing on Grades 9-22)

Description	Model Number <i>Add options below</i>	Base Price	Upholstery	2	3	4	5	6	7	8	Leather	
											1	2
Svelte Seating												
Svelte Uph High Back Chair, Plain Back, No Firecode	SV2HPNO	\$ 1370	High-Back	\$ 1411	\$ 1450	\$ 1489	\$ 1537	\$ 1586	\$ 1634	\$ 1682	\$ 2005	\$ 2523
												
Svelte Uph High Back Chair, Channel Stitch, No Firecode	SV2HCNO	\$ 1612	High-Back	\$ 1653	\$ 1692	\$ 1731	\$ 1779	\$ 1828	\$ 1876	\$ 1924	\$ 2247	\$ 2765
												
Svelte Uph Mid Back Chair, Plain Back, No Firecode	SV2MPNO	\$ 1331	Mid-Back	\$ 1372	\$ 1411	\$ 1450	\$ 1498	\$ 1547	\$ 1595	\$ 1643	\$ 1966	\$ 2484
												
Svelte Uph Mid Back Chair, Channel Stitch, No Firecode	SV2MCNO	\$ 1572	Mid-Back	\$ 1613	\$ 1652	\$ 1691	\$ 1739	\$ 1788	\$ 1836	\$ 1884	\$ 2207	\$ 2725
												

Pricing Example:	Model/Options	Base Price/Upcharges
Step 1: Select Model	SV2MPNO	\$ 1331
Step 2: Select Base	Polished Aluminum	\$ 113 upcharge
Step 3: Select Control	Synchro Seat Slider	\$ 113 upcharge
Step 4: Select Arm	Armless	\$ 0 upcharge
Step 5: Select Upholstery	Grade 8	\$ 312 upcharge
Add Base + applicable Upcharges for Total List Price =		\$ 1869

How to specify — Select the Model Number from above.	1st Option: Select the FSC Option: F FSC Wood	2nd Option: Select the Base Option: BLK Black PAL Polished Aluminum (add \$113 upcharge)	3rd Option: Select the Control Option: B Basic Synchro S Synchro Seat Slider (add \$113 upcharge)	4th Option: Select the Arm Option: A Armless H Height-Adjustable Arms (add \$113 upcharge) F Polished Loop Arms (add \$169 upcharge)	5th Option: Select the Upholstery: See pages 13-14 for selections and pages 17-19 for Color Codes.
S V 2 M P N O .	F .	.	S .	.	.

Example: SV2MPNO.F.PAL.S.B.HAML18

SVELTE

Model Number	Ship		COM Yardage*	Overall			Seat			Arms			Backrest								
	Weight	Cubes		Width	Depth	Height	Height (w/ Control Option)	Width	Depth	Pan Angle (Range)	Armrest Height	Arm Pad Length	Arm Pad Width	Width Between Armrest Uprights	Armrest Pivot	Height	Width	Lumbar Height	Backrest Inclination from Vertical	Backrest/Seat angle (Range)	
SV2HPNO	57	15.9	2.5	42-45½"	26"	26"	16-19½"	17½-23"	20"	16¼"	7°-48°	7½"	11"	1½"	21½"	0°	29"	21½"	8¼"	12°-90°	95°-132°
SV2HCNO	57	15.9	2.5	42-45½"	26"	26"	16-19½"	17½-23"	20"	16¼"	7°-48°	7½"	11"	1½"	21½"	0°	29"	21½"	8¼"	12°-90°	95°-132°
SV2MPNO	53.5	11.3	1.9	35-39½"	26"	26"	18½"-23"	17½-23"	20"	14"-19"	4°-48°	7½"	11"	1½"	21½"	0°	20¾"	18½"	8¼"	12°-90°	98°-132°
SV2MCNO	53.5	11.3	1.9	35-39½"	26"	26"	18½"-23"	17½-23"	20"	14"-19"	4°-48°	7½"	11"	1½"	21½"	0°	20¾"	18½"	8¼"	12°-90°	98°-132°

*COM Yardage is listed for total yardage/feet required for a model, with applicable yardage/feet for individual components listed.

Introducing Vicinity, the newest addition to Allsteel's Social Collaborative collection of furniture.

Your next great idea happens here.

The cafeteria has evolved from a small, back-of-office nook to a vibrant, front-and-center space for planned and impromptu meetings, or for giving guests a taste of your company's culture. Vicinity meets these needs with the flexibility to fit more spaces around your office and a style that's distinctively yours. It's perfect for creative breaks, standing meetings, relaxed eating, or heads-down work.

The best ideas are born from connection. Vicinity gives you the space you need to discover what's possible.

Choose from multiple color and finish combinations to fit the style of your office.

Simple, clean lines serve as the calling card for your company's personality.

Lightweight pieces are easy to move and utilize for whatever your office needs.

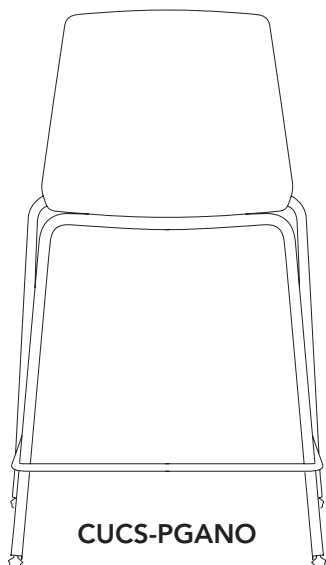
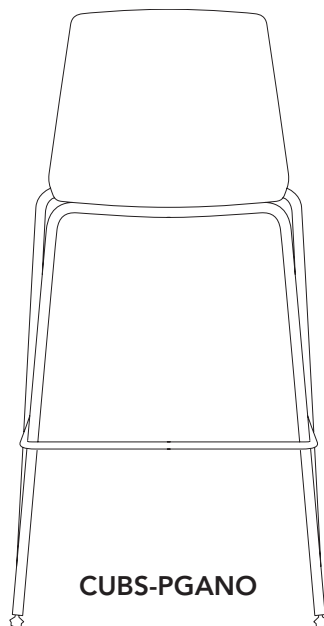
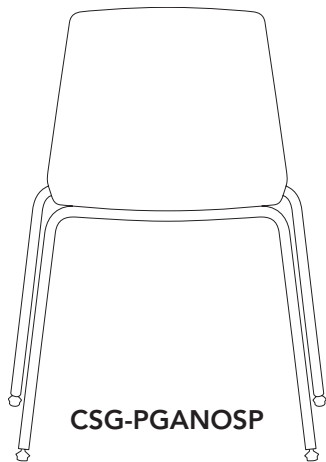
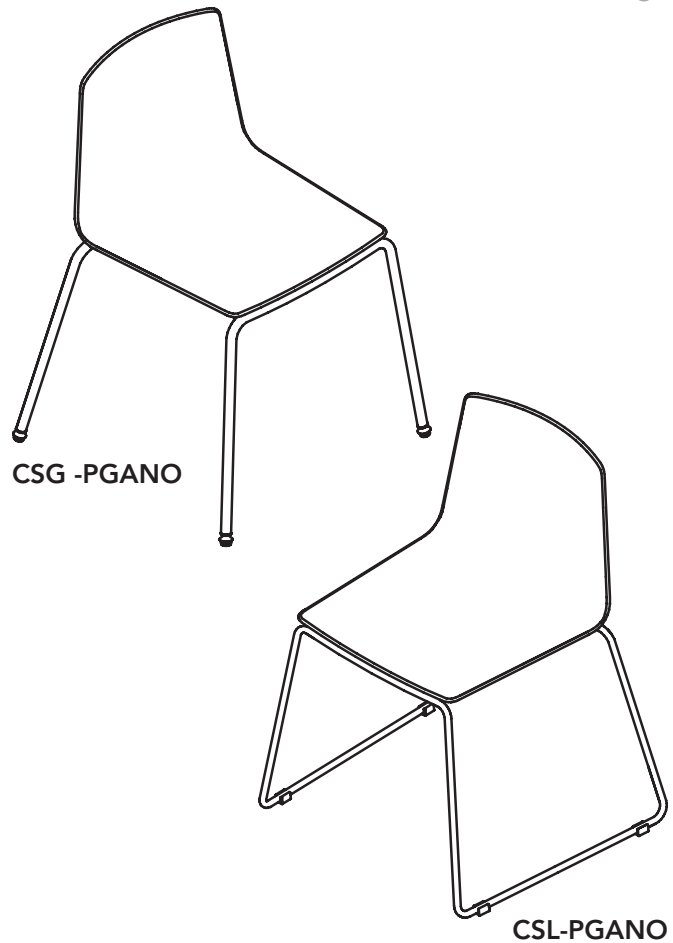

MODELS AND OPTIONS

Vicinity seating is available as seated, counter, or standing heights, with formed wire-frame or tube legs. Vicinity seating is produced using material-efficient processes; little waste is generated during the manufacture of these chairs and what is generated can be recycled into new components. The seating bases all contain at least 25% post-consumer recycled content.

Glides are available in nylon or polycarbonate, nickel-plated or steel, and felt or rubber. Nylon glides or polycarbonate are recommended for hard surfaces, commercial carpet, and damp environments. Nickel-plated and steel glides are recommended for carpet. Felt glides are recommended for wood, tile, or high-sheen floor surfaces.

Vicinity offers 8 different polymer shell colors and nine frame finish colors. 4-Leg and sled base chairs stack up to 10 chairs high in 44"H. Chairs ship up to four per carton to minimize waste. Model number and prices are per chair.

Vicinity meets the requirements set forth in ANSI/BIFMA X5.1-2017. Vicinity is warranted for multiple shifts and users up to 300 lbs.

OPTIONS — CHAIRS / STOOLS

- SG** 4-Leg Chair
- SL** Sled Base Chair
- CS** Counter Stool
- BS** Bar Stool
- UCS** Stacking Counter Stool
- UBS** Stacking Bar Stool

Glides 4-Leg / Stool:

- 0** Nylon for hard surfaces
- 1** Nickel for carpets (add \$19)
- 2** Felt (add \$19)
- 5** Rubber (add \$19)

Glides Sled Base:

- 0** Polycarbonate (only option for Lounge)
- 1** Steel (add \$19)
- 2** Felt (add \$19)



Frame Finish:

- | | |
|---------------------------|-------------------------|
| P71 Black | P097 Harbor |
| PJF Bullseye | P8B Night Bronze |
| PJW Designer White | PJE Pyrite |
| POL Chrome | P095 Sage |
| P096 Cove | PR6 Silver |
| P094 Dune | P8X Solar Black |
| P02 Flint | P8T Titanium |

Poly Shell Colors:

- | | |
|----------------------|--------------------|
| BW Brownstone | OR Quarry |
| CI Citrine | RE Regatta |
| CP Calypso | S Flint |
| CR Cherry | SN Sienna |
| CY Cyprus | ST Salt |
| GE Sage | TI Titanium |
| HR Harbor | UM Umber |
| HZ Haze | WT White |
| LA Lava | ZE Zest |

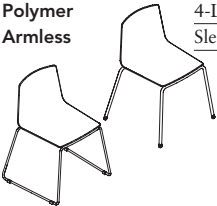
FLOOR COVERING	TYPE OF GLIDE			
	Polycarbonate/Nylon	Felt	Steel	Rubber
Carpet	Best	Not Recommended	Good	Not Recommended
Polished Concrete	Best	Good	Not Recommended	Not Recommended
Hardwood	Not Recommended	Best	Not Recommended	Good
Vinyl (Includes LVT)	Best	Better	Good	Good
VCT	Best	Good	Not Recommended	Good
Tile (Porcelain/Ceramic)	Best	Good	Not Recommended	Good
Attention	Particles can become lodged in nylon and mar floor surface.	Particles can become lodged in felt and mar floor surface.	Cleaning chemicals and water can cause rusting.	Resists moving/sliding. Could lead to chairs tipping back.

Description	Type	Model Number <i>Add options below</i>	List Price
Polymer Armless	4-Leg	CSG-PGANO	\$ 587
	Sled Base	CSL-PGANO	\$ 661
			
Stools Armless	Counter Stool	CUCS-PGANO	\$ 829
	Bar Stool	CUBS-PGANO	\$ 829
			
Seat Pads*	4-Leg Base with Seat Pad	CSG-PGANOSP	\$ 814
	Sled Base with Seat Pad	CSL-PGANOSP	\$ 887
	Counter Stool with Seat Pad	CUCS-PGANOSP	\$ 1054
	Bar Stool with Seat Pad	CUBS-PGANOSP	\$ 1054
			

*List price is for Grade 1 fabric

<p>How to specify — Select the Model Number from above.</p>	<p>1st Option: Select the Glide: 4-Leg/Stool 0 Nylon for hard surfaces 1 Nickel for carpets (add \$19) 2 Felt (add \$19) 5 Rubber (add \$19) Sled Base 0 Polycarbonate 1 Steel (add \$19) 2 Felt (add \$19)</p>	<p>2nd Option: Select the Frame Finish: P71 Black PJF Bullseye PJW Designer White POL Chrome P02 Flint P8B Night Bronze (not available on Lounge) PJE Pyrite PR6 Silver P8X Solar Black P8T Titanium</p>	<p>3rd Option: Select the Poly Shell Color: BW Brownstone QR Quarry CI Citrine RE Regatta CP Calypso S Flint CR Cherry SN Sienna CY Cyprus ST Salt GE Sage TI Titanium HR Harbor UM Umber HZ Haze WT White LA Lava ZE Zest</p>
<p>C P G A N O . .</p>	<p> .</p>	<p> .</p>	<p> </p>

Examples: CSG-PGANO.1.P71.CR CSL-PGANO.2.POL.WT



Model Number	Overall			Seat				Backrest							
	Height (Range)	Width	Depth	Height	Width	Depth	Pan Angle	Height	Width	Lumbar-Height	Backrest/Seat Angle (Range)	Ship Weight Per Chair	Ship Weight Per Carton	Cubes	COM Yardage
CSG-PGANO	31"	24"	21½"	17½"	17½"	16½"	2.4°	14"	17"	10"	100°-106°	24	66	16	
CSL-PGANO	30½"	23½"	21"	17½"	17½"	16½"	2.4°	14"	17"	10"	100°-106°	24	66	16	
CCS-PGANO	37½"	18"	18½"	24¼"	17½"	16½"	0.7°	14"	17"	10"	99°-105°	25	25	14	
CBS-PGANO	43½"	18½"	18½"	30¼"	17½"	16½"	0.7°	14"	17"	10"	99°-105°	25	25	14	
CUCS-PGANO	37½"	18"	18½"	24¼"	17½"	16½"	0.7°	14"	17"	10"	99°-105°	47	38	16	0.60
CUBS-PGANO	43½"	18½"	18½"	30¼"	17½"	16½"	0.7°	14"	17"	10"	99°-105°	52	40	19	0.60
CSG-PGANOSP	31"	24"	21½"	17½"	17½"	16½"	2.4°	14"	17"	10"	100°-106°	68	37	16	0.60
CSL-PGANOSP	30½"	23½"	21"	17½"	17½"	16½"	2.4°	14"	17"	10"	100°-106°	72	39	16	0.60
CUCS-PGANOSP	37½"	18"	18½"	24¼"	17½"	16½"	0.7°	14"	17"	10"	99°-105°	50	47	16	0.60
CUBS-PGANOSP	43½"	18½"	18½"	30¼"	17½"	16½"	0.7°	14"	17"	10"	99°-105°	55	52	19	0.60

Vicinity 4-Leg and Sled Base chairs ship up to four per carton to minimize waste. Model numbers and prices are per chair. Stools ship one per carton. Vicinity 4-Leg, Sled Base, and Stackable stools can be stacked up to 10-high and stacked up to 5-high with a seat pad.

Seating

Fabric Grades 9-22 Pricing

GSA SIN 33721

Model Number		Grade 9	Grade 10	Grade 11	Grade 12	Grade 13	Grade 14	Grade 15	Grade 16	Grade 17	Grade 18	Grade 19	Grade 20	Grade 21	Grade 22
ACUITY — Pages 48-51															
AAMG		\$ 2921	\$ 2970	\$ 3017	\$ 3074	\$ 3129	\$ 3185	\$ 3242	\$ 3297	\$ 3354	\$ 3409	\$ 3465	\$ 3522	\$ 3578	\$ 3634
AAMS		\$ 2921	\$ 2970	\$ 3017	\$ 3074	\$ 3129	\$ 3185	\$ 3242	\$ 3297	\$ 3354	\$ 3409	\$ 3465	\$ 3522	\$ 3578	\$ 3634
AAMW		\$ 2921	\$ 2970	\$ 3017	\$ 3074	\$ 3129	\$ 3185	\$ 3242	\$ 3297	\$ 3354	\$ 3409	\$ 3465	\$ 3522	\$ 3578	\$ 3634
AAMP		\$ 3511	\$ 3560	\$ 3607	\$ 3664	\$ 3719	\$ 3775	\$ 3832	\$ 3887	\$ 3944	\$ 3999	\$ 4055	\$ 4112	\$ 4168	\$ 4224
<hr/>															
AFMG		\$ 3247	\$ 3296	\$ 3343	\$ 3400	\$ 3455	\$ 3511	\$ 3568	\$ 3623	\$ 3680	\$ 3735	\$ 3791	\$ 3848	\$ 3904	\$ 3960
AFMS		\$ 3247	\$ 3296	\$ 3343	\$ 3400	\$ 3455	\$ 3511	\$ 3568	\$ 3623	\$ 3680	\$ 3735	\$ 3791	\$ 3848	\$ 3904	\$ 3960
AFMW		\$ 3247	\$ 3296	\$ 3343	\$ 3400	\$ 3455	\$ 3511	\$ 3568	\$ 3623	\$ 3680	\$ 3735	\$ 3791	\$ 3848	\$ 3904	\$ 3960
AFMP		\$ 3836	\$ 3885	\$ 3932	\$ 3989	\$ 4044	\$ 4100	\$ 4157	\$ 4212	\$ 4269	\$ 4324	\$ 4380	\$ 4437	\$ 4493	\$ 4549
<hr/>															
AWMG		\$ 3135	\$ 3184	\$ 3231	\$ 3288	\$ 3343	\$ 3399	\$ 3456	\$ 3511	\$ 3568	\$ 3623	\$ 3679	\$ 3736	\$ 3792	\$ 3848
AWMS		\$ 3135	\$ 3184	\$ 3231	\$ 3288	\$ 3343	\$ 3399	\$ 3456	\$ 3511	\$ 3568	\$ 3623	\$ 3679	\$ 3736	\$ 3792	\$ 3848
AWMW		\$ 3135	\$ 3184	\$ 3231	\$ 3288	\$ 3343	\$ 3399	\$ 3456	\$ 3511	\$ 3568	\$ 3623	\$ 3679	\$ 3736	\$ 3792	\$ 3848
AWMP		\$ 3726	\$ 3775	\$ 3822	\$ 3879	\$ 3934	\$ 3990	\$ 4047	\$ 4102	\$ 4159	\$ 4214	\$ 4270	\$ 4327	\$ 4383	\$ 4439
<hr/>															
ACUITY SIDE — Pages 52-55															
ACM-MUGO		\$ 1487	\$ 1529	\$ 1573	\$ 1632	\$ 1693	\$ 1753	\$ 1814	\$ 1876	\$ 1936	\$ 1995	\$ 2056	\$ 2118	\$ 2179	\$ 2240
ACM-MUGA		\$ 1419	\$ 1461	\$ 1505	\$ 1564	\$ 1625	\$ 1685	\$ 1746	\$ 1808	\$ 1868	\$ 1927	\$ 1988	\$ 2050	\$ 2111	\$ 2172
ACM-MUCO		\$ 1578	\$ 1620	\$ 1664	\$ 1723	\$ 1784	\$ 1844	\$ 1905	\$ 1967	\$ 2027	\$ 2086	\$ 2147	\$ 2209	\$ 2270	\$ 2331
ACM-MUCA		\$ 1510	\$ 1552	\$ 1596	\$ 1655	\$ 1716	\$ 1776	\$ 1837	\$ 1899	\$ 1959	\$ 2018	\$ 2079	\$ 2141	\$ 2202	\$ 2263
<hr/>															
EVO WORK — Pages 60-63 Upholstery upcharges below for Grades 9-22 need to be to added to Base Price listed on page 62.															
DWW-MHWNO	Seat	\$ 187	\$ 212	\$ 236	\$ 266	\$ 296	\$ 326	\$ 356	\$ 385	\$ 416	\$ 444	\$ 474	\$ 504	\$ 534	\$ 564
DWW-MHHNO	Seat	\$ 187	\$ 212	\$ 236	\$ 266	\$ 296	\$ 326	\$ 356	\$ 385	\$ 416	\$ 444	\$ 474	\$ 504	\$ 534	\$ 564
DWW-MHFNO	Seat	\$ 187	\$ 212	\$ 236	\$ 266	\$ 296	\$ 326	\$ 356	\$ 385	\$ 416	\$ 444	\$ 474	\$ 504	\$ 534	\$ 564
DWW-MHANO	Seat	\$ 187	\$ 212	\$ 236	\$ 266	\$ 296	\$ 326	\$ 356	\$ 385	\$ 416	\$ 444	\$ 474	\$ 504	\$ 534	\$ 564
<hr/>															
EVO CONFERENCE — Pages 62-63 Upholstery upcharges below for Grades 9-22 need to be to added to Base Price listed on page 62.															
DWC-UMWNO	Back	\$ 281	\$ 318	\$ 355	\$ 398	\$ 444	\$ 489	\$ 533	\$ 577	\$ 623	\$ 667	\$ 711	\$ 755	\$ 802	\$ 845
	Seat	\$ 187	\$ 212	\$ 236	\$ 266	\$ 296	\$ 326	\$ 356	\$ 385	\$ 416	\$ 444	\$ 474	\$ 504	\$ 534	\$ 564
DWC-UMHNO	Back	\$ 281	\$ 318	\$ 355	\$ 398	\$ 444	\$ 489	\$ 533	\$ 577	\$ 623	\$ 667	\$ 711	\$ 755	\$ 802	\$ 845
	Seat	\$ 187	\$ 212	\$ 236	\$ 266	\$ 296	\$ 326	\$ 356	\$ 385	\$ 416	\$ 444	\$ 474	\$ 504	\$ 534	\$ 564
DWC-UMFNO	Back	\$ 281	\$ 318	\$ 355	\$ 398	\$ 444	\$ 489	\$ 533	\$ 577	\$ 623	\$ 667	\$ 711	\$ 755	\$ 802	\$ 845
	Seat	\$ 187	\$ 212	\$ 236	\$ 266	\$ 296	\$ 326	\$ 356	\$ 385	\$ 416	\$ 444	\$ 474	\$ 504	\$ 534	\$ 564
DWC-UMANO	Back	\$ 281	\$ 318	\$ 355	\$ 398	\$ 444	\$ 489	\$ 533	\$ 577	\$ 623	\$ 667	\$ 711	\$ 755	\$ 802	\$ 845
	Seat	\$ 187	\$ 212	\$ 236	\$ 266	\$ 296	\$ 326	\$ 356	\$ 385	\$ 416	\$ 444	\$ 474	\$ 504	\$ 534	\$ 564
<hr/>															
EVO STOOL — Page 64															
DWS-MHWNO		\$ 2228	\$ 2253	\$ 2277	\$ 2307	\$ 2337	\$ 2367	\$ 2397	\$ 2426	\$ 2457	\$ 2485	\$ 2515	\$ 2545	\$ 2575	\$ 2605
DWS-MHHNO		\$ 2152	\$ 2177	\$ 2201	\$ 2231	\$ 2261	\$ 2291	\$ 2321	\$ 2350	\$ 2381	\$ 2409	\$ 2439	\$ 2469	\$ 2499	\$ 2529
DWS-MHFNO		\$ 2202	\$ 2227	\$ 2251	\$ 2281	\$ 2311	\$ 2341	\$ 2371	\$ 2400	\$ 2431	\$ 2459	\$ 2489	\$ 2519	\$ 2549	\$ 2579
DWS-MHANO		\$ 2029	\$ 2054	\$ 2078	\$ 2108	\$ 2138	\$ 2168	\$ 2198	\$ 2227	\$ 2258	\$ 2286	\$ 2316	\$ 2346	\$ 2376	\$ 2406
<hr/>															
EVO SIDE — Page 65															
DSC-MUCONO		\$ 1101	\$ 1126	\$ 1150	\$ 1180	\$ 1210	\$ 1240	\$ 1270	\$ 1299	\$ 1330	\$ 1358	\$ 1388	\$ 1418	\$ 1448	\$ 1478
DSC-MUGONO		\$ 1055	\$ 1080	\$ 1104	\$ 1134	\$ 1164	\$ 1194	\$ 1224	\$ 1253	\$ 1284	\$ 1312	\$ 1342	\$ 1372	\$ 1402	\$ 1432

Seating

Fabric Grades 9-22 Pricing

GSA SIN 33721

Model Number	Grade 9	Grade 10	Grade 11	Grade 12	Grade 13	Grade 14	Grade 15	Grade 16	Grade 17	Grade 18	Grade 19	Grade 20	Grade 21	Grade 22
INSPIRE — Pages 67-85														
INFS-SGO	\$ 1755	\$ 1782	\$ 1810	\$ 1841	\$ 1873	\$ 1904	\$ 1937	\$ 1967	\$ 2000	\$ 2030	\$ 2063	\$ 2094	\$ 2127	\$ 2159
INFS-SGA	\$ 1627	\$ 1654	\$ 1682	\$ 1713	\$ 1745	\$ 1776	\$ 1809	\$ 1839	\$ 1872	\$ 1902	\$ 1935	\$ 1966	\$ 1999	\$ 2031
INFS-UGO	\$ 2074	\$ 2120	\$ 2168	\$ 2223	\$ 2278	\$ 2332	\$ 2387	\$ 2442	\$ 2497	\$ 2552	\$ 2607	\$ 2663	\$ 2716	\$ 2772
INFS-UGA	\$ 1946	\$ 1992	\$ 2040	\$ 2095	\$ 2150	\$ 2204	\$ 2259	\$ 2314	\$ 2369	\$ 2424	\$ 2479	\$ 2535	\$ 2588	\$ 2644
INSL-SO	\$ 1208	\$ 1235	\$ 1263	\$ 1294	\$ 1326	\$ 1357	\$ 1390	\$ 1420	\$ 1453	\$ 1483	\$ 1516	\$ 1547	\$ 1580	\$ 1612
INSL-SA	\$ 1075	\$ 1102	\$ 1130	\$ 1161	\$ 1193	\$ 1224	\$ 1257	\$ 1287	\$ 1320	\$ 1350	\$ 1383	\$ 1414	\$ 1447	\$ 1479
INSL-UO	\$ 1527	\$ 1573	\$ 1621	\$ 1676	\$ 1731	\$ 1785	\$ 1840	\$ 1895	\$ 1950	\$ 2005	\$ 2060	\$ 2116	\$ 2169	\$ 2225
INSL-UA	\$ 1393	\$ 1439	\$ 1487	\$ 1542	\$ 1597	\$ 1651	\$ 1706	\$ 1761	\$ 1816	\$ 1871	\$ 1926	\$ 1982	\$ 2035	\$ 2091
INST-SGO	\$ 1213	\$ 1240	\$ 1268	\$ 1299	\$ 1331	\$ 1362	\$ 1395	\$ 1425	\$ 1458	\$ 1488	\$ 1521	\$ 1552	\$ 1585	\$ 1617
INST-SCO	\$ 1256	\$ 1283	\$ 1311	\$ 1342	\$ 1374	\$ 1405	\$ 1438	\$ 1468	\$ 1501	\$ 1531	\$ 1564	\$ 1595	\$ 1628	\$ 1660
INST-SGA	\$ 1075	\$ 1102	\$ 1130	\$ 1161	\$ 1193	\$ 1224	\$ 1257	\$ 1287	\$ 1320	\$ 1350	\$ 1383	\$ 1414	\$ 1447	\$ 1479
INST-SCA	\$ 1120	\$ 1147	\$ 1175	\$ 1206	\$ 1238	\$ 1269	\$ 1302	\$ 1332	\$ 1365	\$ 1395	\$ 1428	\$ 1459	\$ 1492	\$ 1524
INST-UGO	\$ 1530	\$ 1576	\$ 1624	\$ 1679	\$ 1734	\$ 1788	\$ 1843	\$ 1898	\$ 1953	\$ 2008	\$ 2063	\$ 2119	\$ 2172	\$ 2228
INST-UCO	\$ 1576	\$ 1622	\$ 1670	\$ 1725	\$ 1780	\$ 1834	\$ 1889	\$ 1944	\$ 1999	\$ 2054	\$ 2109	\$ 2165	\$ 2218	\$ 2274
INST-UGA	\$ 1393	\$ 1439	\$ 1487	\$ 1542	\$ 1597	\$ 1651	\$ 1706	\$ 1761	\$ 1816	\$ 1871	\$ 1926	\$ 1982	\$ 2035	\$ 2091
INST-UCA	\$ 1440	\$ 1486	\$ 1534	\$ 1589	\$ 1644	\$ 1698	\$ 1753	\$ 1808	\$ 1863	\$ 1918	\$ 1973	\$ 2029	\$ 2082	\$ 2138
INSTT-SGAFRS	\$ 1515	\$ 1540	\$ 1567	\$ 1598	\$ 1630	\$ 1661	\$ 1694	\$ 1726	\$ 1757	\$ 1788	\$ 1820	\$ 1852	\$ 1884	\$ 1916
INSTT-SCAFRS	\$ 1559	\$ 1584	\$ 1611	\$ 1642	\$ 1674	\$ 1705	\$ 1738	\$ 1770	\$ 1801	\$ 1832	\$ 1864	\$ 1896	\$ 1928	\$ 1960
INSTT-SGAFLS	\$ 1515	\$ 1540	\$ 1567	\$ 1598	\$ 1630	\$ 1661	\$ 1694	\$ 1726	\$ 1757	\$ 1788	\$ 1820	\$ 1852	\$ 1884	\$ 1916
INSTT-SCAFLS	\$ 1559	\$ 1584	\$ 1611	\$ 1642	\$ 1674	\$ 1705	\$ 1738	\$ 1770	\$ 1801	\$ 1832	\$ 1864	\$ 1896	\$ 1928	\$ 1960
INSTT-UGAFRS	\$ 1852	\$ 1901	\$ 1948	\$ 2003	\$ 2060	\$ 2116	\$ 2172	\$ 2229	\$ 2282	\$ 2340	\$ 2397	\$ 2451	\$ 2509	\$ 2565
INSTT-UCAFRS	\$ 1898	\$ 1947	\$ 1994	\$ 2049	\$ 2106	\$ 2162	\$ 2218	\$ 2275	\$ 2328	\$ 2386	\$ 2443	\$ 2497	\$ 2555	\$ 2611
INSTT-UGAFLS	\$ 1852	\$ 1901	\$ 1948	\$ 2003	\$ 2060	\$ 2116	\$ 2172	\$ 2229	\$ 2282	\$ 2340	\$ 2397	\$ 2451	\$ 2509	\$ 2565
INSTT-UCAFLS	\$ 1898	\$ 1947	\$ 1994	\$ 2049	\$ 2106	\$ 2162	\$ 2218	\$ 2275	\$ 2328	\$ 2386	\$ 2443	\$ 2497	\$ 2555	\$ 2611
INTK-SO	\$ 1496	\$ 1523	\$ 1551	\$ 1582	\$ 1614	\$ 1645	\$ 1678	\$ 1708	\$ 1741	\$ 1771	\$ 1804	\$ 1835	\$ 1868	\$ 1900
INTK-SA	\$ 1361	\$ 1388	\$ 1416	\$ 1447	\$ 1479	\$ 1510	\$ 1543	\$ 1573	\$ 1606	\$ 1636	\$ 1669	\$ 1700	\$ 1733	\$ 1765
INTK-UO	\$ 1814	\$ 1860	\$ 1908	\$ 1963	\$ 2018	\$ 2072	\$ 2127	\$ 2182	\$ 2237	\$ 2292	\$ 2347	\$ 2403	\$ 2456	\$ 2512
INTK-UA	\$ 1679	\$ 1725	\$ 1773	\$ 1828	\$ 1883	\$ 1937	\$ 1992	\$ 2047	\$ 2102	\$ 2157	\$ 2212	\$ 2268	\$ 2321	\$ 2377
INWS-SO	\$ 1761	\$ 1788	\$ 1816	\$ 1847	\$ 1879	\$ 1910	\$ 1943	\$ 1973	\$ 2006	\$ 2036	\$ 2069	\$ 2100	\$ 2133	\$ 2165
INWS-SA	\$ 1627	\$ 1654	\$ 1682	\$ 1713	\$ 1745	\$ 1776	\$ 1809	\$ 1839	\$ 1872	\$ 1902	\$ 1935	\$ 1966	\$ 1999	\$ 2031
INWS-UO	\$ 2080	\$ 2126	\$ 2174	\$ 2229	\$ 2284	\$ 2338	\$ 2393	\$ 2448	\$ 2503	\$ 2558	\$ 2613	\$ 2669	\$ 2722	\$ 2778
INWS-UA	\$ 1946	\$ 1992	\$ 2040	\$ 2095	\$ 2150	\$ 2204	\$ 2259	\$ 2314	\$ 2369	\$ 2424	\$ 2479	\$ 2535	\$ 2588	\$ 2644

Seating

Fabric Grades 9-22 Pricing

GSA SIN 33721

Model Number	Grade 9	Grade 10	Grade 11	Grade 12	Grade 13	Grade 14	Grade 15	Grade 16	Grade 17	Grade 18	Grade 19	Grade 20	Grade 21	Grade 22
LYRIC WORK — Pages 86-89														
CWW-MHW	\$ 1647	\$ 1672	\$ 1696	\$ 1731	\$ 1766	\$ 1802	\$ 1838	\$ 1873	\$ 1909	\$ 1943	\$ 1979	\$ 2016	\$ 2051	\$ 2122
CWW-MMW	\$ 1611	\$ 1636	\$ 1660	\$ 1695	\$ 1730	\$ 1766	\$ 1802	\$ 1837	\$ 1873	\$ 1907	\$ 1943	\$ 1980	\$ 2015	\$ 2086
CSW-MHW	\$ 1523	\$ 1548	\$ 1572	\$ 1607	\$ 1642	\$ 1678	\$ 1714	\$ 1749	\$ 1785	\$ 1819	\$ 1855	\$ 1892	\$ 1927	\$ 1998
CSW-MMW	\$ 1487	\$ 1512	\$ 1536	\$ 1571	\$ 1606	\$ 1642	\$ 1678	\$ 1713	\$ 1749	\$ 1783	\$ 1819	\$ 1856	\$ 1891	\$ 1962
CBW-MHW	\$ 1461	\$ 1486	\$ 1510	\$ 1545	\$ 1580	\$ 1616	\$ 1652	\$ 1687	\$ 1723	\$ 1757	\$ 1793	\$ 1830	\$ 1865	\$ 1936
CBW-MMW	\$ 1427	\$ 1452	\$ 1476	\$ 1511	\$ 1546	\$ 1582	\$ 1618	\$ 1653	\$ 1689	\$ 1723	\$ 1759	\$ 1796	\$ 1831	\$ 1902
CWW-MHH	\$ 1571	\$ 1596	\$ 1620	\$ 1655	\$ 1690	\$ 1726	\$ 1762	\$ 1797	\$ 1833	\$ 1867	\$ 1903	\$ 1940	\$ 1975	\$ 2046
CWW-MMH	\$ 1535	\$ 1560	\$ 1584	\$ 1619	\$ 1654	\$ 1690	\$ 1726	\$ 1761	\$ 1797	\$ 1831	\$ 1867	\$ 1904	\$ 1939	\$ 2010
CSW-MHH	\$ 1448	\$ 1473	\$ 1497	\$ 1532	\$ 1567	\$ 1603	\$ 1639	\$ 1674	\$ 1710	\$ 1744	\$ 1780	\$ 1817	\$ 1852	\$ 1923
CSW-MMH	\$ 1412	\$ 1437	\$ 1461	\$ 1496	\$ 1531	\$ 1567	\$ 1603	\$ 1638	\$ 1674	\$ 1708	\$ 1744	\$ 1781	\$ 1816	\$ 1887
CBW-MHH	\$ 1387	\$ 1412	\$ 1436	\$ 1471	\$ 1506	\$ 1542	\$ 1578	\$ 1613	\$ 1649	\$ 1683	\$ 1719	\$ 1756	\$ 1791	\$ 1862
CBW-MMH	\$ 1352	\$ 1377	\$ 1401	\$ 1436	\$ 1471	\$ 1507	\$ 1543	\$ 1578	\$ 1614	\$ 1648	\$ 1684	\$ 1721	\$ 1756	\$ 1827
CWW-MHF	\$ 1582	\$ 1607	\$ 1631	\$ 1666	\$ 1701	\$ 1737	\$ 1773	\$ 1808	\$ 1844	\$ 1878	\$ 1914	\$ 1951	\$ 1986	\$ 2057
CWW-MMF	\$ 1547	\$ 1572	\$ 1596	\$ 1631	\$ 1666	\$ 1702	\$ 1738	\$ 1773	\$ 1809	\$ 1843	\$ 1879	\$ 1916	\$ 1951	\$ 2022
CSW-MHF	\$ 1459	\$ 1484	\$ 1508	\$ 1543	\$ 1578	\$ 1614	\$ 1650	\$ 1685	\$ 1721	\$ 1755	\$ 1791	\$ 1828	\$ 1863	\$ 1934
CSW-MMF	\$ 1424	\$ 1449	\$ 1473	\$ 1508	\$ 1543	\$ 1579	\$ 1615	\$ 1650	\$ 1686	\$ 1720	\$ 1756	\$ 1793	\$ 1828	\$ 1899
CBW-MHF	\$ 1397	\$ 1422	\$ 1446	\$ 1481	\$ 1516	\$ 1552	\$ 1588	\$ 1623	\$ 1659	\$ 1693	\$ 1729	\$ 1766	\$ 1801	\$ 1872
CBW-MMF	\$ 1361	\$ 1386	\$ 1410	\$ 1445	\$ 1480	\$ 1516	\$ 1552	\$ 1587	\$ 1623	\$ 1657	\$ 1693	\$ 1730	\$ 1765	\$ 1836
CWW-MHA	\$ 1449	\$ 1474	\$ 1498	\$ 1533	\$ 1568	\$ 1604	\$ 1640	\$ 1675	\$ 1711	\$ 1745	\$ 1781	\$ 1818	\$ 1853	\$ 1924
CWW-MMA	\$ 1413	\$ 1438	\$ 1462	\$ 1497	\$ 1532	\$ 1568	\$ 1604	\$ 1639	\$ 1675	\$ 1709	\$ 1745	\$ 1782	\$ 1817	\$ 1888
CSW-MHA	\$ 1327	\$ 1352	\$ 1376	\$ 1411	\$ 1446	\$ 1482	\$ 1518	\$ 1553	\$ 1589	\$ 1623	\$ 1659	\$ 1696	\$ 1731	\$ 1802
CSW-MMA	\$ 1291	\$ 1316	\$ 1340	\$ 1375	\$ 1410	\$ 1446	\$ 1482	\$ 1517	\$ 1553	\$ 1587	\$ 1623	\$ 1660	\$ 1695	\$ 1766
CBW-MHA	\$ 1266	\$ 1291	\$ 1315	\$ 1350	\$ 1385	\$ 1421	\$ 1457	\$ 1492	\$ 1528	\$ 1562	\$ 1598	\$ 1635	\$ 1670	\$ 1741
CBW-MMA	\$ 1229	\$ 1254	\$ 1278	\$ 1313	\$ 1348	\$ 1384	\$ 1420	\$ 1455	\$ 1491	\$ 1525	\$ 1561	\$ 1598	\$ 1633	\$ 1704
LYRIC STOOL — Pages 90-91 (upholstered on page 148)														
CSS-MHW	\$ 1935	\$ 1954	\$ 1973	\$ 2000	\$ 2028	\$ 2057	\$ 2085	\$ 2112	\$ 2140	\$ 2167	\$ 2196	\$ 2224	\$ 2251	\$ 2308
CSS-MMW	\$ 1907	\$ 1926	\$ 1945	\$ 1972	\$ 2000	\$ 2029	\$ 2057	\$ 2084	\$ 2112	\$ 2139	\$ 2168	\$ 2196	\$ 2223	\$ 2280
CSS-MHH	\$ 1875	\$ 1894	\$ 1913	\$ 1940	\$ 1968	\$ 1997	\$ 2025	\$ 2052	\$ 2080	\$ 2107	\$ 2136	\$ 2164	\$ 2191	\$ 2248
CSS-MMH	\$ 1848	\$ 1867	\$ 1886	\$ 1913	\$ 1941	\$ 1970	\$ 1998	\$ 2025	\$ 2053	\$ 2080	\$ 2109	\$ 2137	\$ 2164	\$ 2221
CSS-MHF	\$ 1885	\$ 1904	\$ 1923	\$ 1950	\$ 1978	\$ 2007	\$ 2035	\$ 2062	\$ 2090	\$ 2117	\$ 2146	\$ 2174	\$ 2201	\$ 2258
CSS-MMF	\$ 1857	\$ 1876	\$ 1895	\$ 1922	\$ 1950	\$ 1979	\$ 2007	\$ 2034	\$ 2062	\$ 2089	\$ 2118	\$ 2146	\$ 2173	\$ 2230
CSS-MHA	\$ 1780	\$ 1799	\$ 1818	\$ 1845	\$ 1873	\$ 1902	\$ 1930	\$ 1957	\$ 1985	\$ 2012	\$ 2041	\$ 2069	\$ 2096	\$ 2153
CSS-MMA	\$ 1751	\$ 1770	\$ 1789	\$ 1816	\$ 1844	\$ 1873	\$ 1901	\$ 1928	\$ 1956	\$ 1983	\$ 2012	\$ 2040	\$ 2067	\$ 2124
LYRIC L & T — Pages 92-93 (upholstered on page 148)														
CLL-MLH	\$ 2079	\$ 2104	\$ 2128	\$ 2163	\$ 2198	\$ 2234	\$ 2270	\$ 2305	\$ 2341	\$ 2375	\$ 2411	\$ 2448	\$ 2483	\$ 2554
CLL-MLF	\$ 2090	\$ 2115	\$ 2139	\$ 2174	\$ 2209	\$ 2245	\$ 2281	\$ 2316	\$ 2352	\$ 2386	\$ 2422	\$ 2459	\$ 2494	\$ 2565
CLL-MLA	\$ 1958	\$ 1983	\$ 2007	\$ 2042	\$ 2077	\$ 2113	\$ 2149	\$ 2184	\$ 2220	\$ 2254	\$ 2290	\$ 2327	\$ 2362	\$ 2433
LYRIC SIDE — Pages 94-95														
CSC-MUGO	\$ 1125	\$ 1170	\$ 1215	\$ 1273	\$ 1332	\$ 1392	\$ 1449	\$ 1509	\$ 1568	\$ 1628	\$ 1685	\$ 1745	\$ 1805	\$ 1848
CSC-UUGO	\$ 1246	\$ 1291	\$ 1336	\$ 1394	\$ 1453	\$ 1513	\$ 1570	\$ 1630	\$ 1689	\$ 1749	\$ 1806	\$ 1866	\$ 1926	\$ 1969
CSC-MUCO	\$ 1170	\$ 1215	\$ 1260	\$ 1318	\$ 1377	\$ 1437	\$ 1494	\$ 1554	\$ 1613	\$ 1673	\$ 1730	\$ 1790	\$ 1850	\$ 1893
CSC-UUCO	\$ 1292	\$ 1337	\$ 1382	\$ 1440	\$ 1499	\$ 1559	\$ 1616	\$ 1676	\$ 1735	\$ 1795	\$ 1852	\$ 1912	\$ 1972	\$ 2015
Lyric Multi-Purpose Work Chair — Pages 96-97														
CMPWU-PPCONO	\$ 1220	\$ 1246	\$ 1272	\$ 1301	\$ 1332	\$ 1362	\$ 1394	\$ 1424	\$ 1456	\$ 1485	\$ 1517	\$ 1547	\$ 1579	\$ 1608
CMPWU-PPCANO	\$ 1083	\$ 1109	\$ 1135	\$ 1164	\$ 1195	\$ 1225	\$ 1257	\$ 1287	\$ 1319	\$ 1348	\$ 1380	\$ 1410	\$ 1442	\$ 1471
Lyric Multi-Purpose 4 Leg Stacker and Stools with Seat Pads — Pages 100-101														
CMPNU-PPGO	\$ 886	\$ 911	\$ 935	\$ 965	\$ 995	\$ 1025	\$ 1055	\$ 1084	\$ 1115	\$ 1143	\$ 1173	\$ 1203	\$ 1233	\$ 1263
CMPNU-PPCO	\$ 932	\$ 957	\$ 981	\$ 1011	\$ 1041	\$ 1071	\$ 1101	\$ 1130	\$ 1161	\$ 1189	\$ 1219	\$ 1249	\$ 1279	\$ 1309
CMPNU-PPGA	\$ 751	\$ 776	\$ 800	\$ 830	\$ 860	\$ 890	\$ 920	\$ 949	\$ 980	\$ 1008	\$ 1038	\$ 1068	\$ 1098	\$ 1128
CMPNU-PPCA	\$ 796	\$ 821	\$ 845	\$ 875	\$ 905	\$ 935	\$ 965	\$ 994	\$ 1025	\$ 1053	\$ 1083	\$ 1113	\$ 1143	\$ 1173
CWSU-PPGO	\$ 991	\$ 1017	\$ 1043	\$ 1072	\$ 1103	\$ 1133	\$ 1165	\$ 1195	\$ 1227	\$ 1256	\$ 1288	\$ 1318	\$ 1350	\$ 1379
CWSU-PPGA	\$ 853	\$ 879	\$ 905	\$ 934	\$ 965	\$ 995	\$ 1027	\$ 1057	\$ 1089	\$ 1118	\$ 1150	\$ 1180	\$ 1212	\$ 1241
CWS30U-PPGA	\$ 999	\$ 1025	\$ 1051	\$ 1080	\$ 1111	\$ 1141	\$ 1173	\$ 1203	\$ 1235	\$ 1264	\$ 1296	\$ 1326	\$ 1358	\$ 1387

Seating

Fabric Grades 9-22 Pricing

GSA SIN 33721

Model Number	Grade 9	Grade 10	Grade 11	Grade 12	Grade 13	Grade 14	Grade 15	Grade 16	Grade 17	Grade 18	Grade 19	Grade 20	Grade 21	Grade 22
MIMEO — Pages 102-105														
MIW-KWNO	\$ 2218	\$ 2242	\$ 2264	\$ 2294	\$ 2322	\$ 2349	\$ 2377	\$ 2405	\$ 2434	\$ 2462	\$ 2491	\$ 2518	\$ 2547	\$ 2575
MIS-KWNO	\$ 2644	\$ 2668	\$ 2690	\$ 2720	\$ 2748	\$ 2775	\$ 2803	\$ 2831	\$ 2860	\$ 2888	\$ 2917	\$ 2944	\$ 2973	\$ 3001
MIW-KANO	\$ 1935	\$ 1959	\$ 1981	\$ 2011	\$ 2039	\$ 2066	\$ 2094	\$ 2122	\$ 2151	\$ 2179	\$ 2208	\$ 2235	\$ 2264	\$ 2292
MIS-KANO	\$ 2361	\$ 2385	\$ 2407	\$ 2437	\$ 2465	\$ 2492	\$ 2520	\$ 2548	\$ 2577	\$ 2605	\$ 2634	\$ 2661	\$ 2690	\$ 2718
O6 — Pages 108-111														
MNL-MHW	\$ 1361	\$ 1388	\$ 1414	\$ 1440	\$ 1474	\$ 1507	\$ 1540	\$ 1573	\$ 1607	\$ 1640	\$ 1673	\$ 1707	\$ 1740	\$ 1773
MNL-MHH	\$ 1295	\$ 1322	\$ 1348	\$ 1374	\$ 1408	\$ 1441	\$ 1474	\$ 1507	\$ 1541	\$ 1574	\$ 1607	\$ 1641	\$ 1674	\$ 1707
MNL-MHA	\$ 1182	\$ 1209	\$ 1235	\$ 1261	\$ 1295	\$ 1328	\$ 1361	\$ 1394	\$ 1428	\$ 1461	\$ 1494	\$ 1528	\$ 1561	\$ 1594
MNLS-MHW	\$ 1541	\$ 1568	\$ 1594	\$ 1620	\$ 1654	\$ 1687	\$ 1720	\$ 1753	\$ 1787	\$ 1820	\$ 1853	\$ 1887	\$ 1920	\$ 1953
MNLS-MHH	\$ 1474	\$ 1501	\$ 1527	\$ 1553	\$ 1587	\$ 1620	\$ 1653	\$ 1686	\$ 1720	\$ 1753	\$ 1786	\$ 1820	\$ 1853	\$ 1886
MNLS-MHA	\$ 1361	\$ 1388	\$ 1414	\$ 1440	\$ 1474	\$ 1507	\$ 1540	\$ 1573	\$ 1607	\$ 1640	\$ 1673	\$ 1707	\$ 1740	\$ 1773
PLI — Pages 112-115														
FWW-MHHNO	\$ 1602	\$ 1630	\$ 1658	\$ 1687	\$ 1723	\$ 1757	\$ 1793	\$ 1828	\$ 1864	\$ 1899	\$ 1935	\$ 1969	\$ 2004	\$ 2040
FWW-MHFNO	\$ 1566	\$ 1594	\$ 1622	\$ 1651	\$ 1687	\$ 1721	\$ 1757	\$ 1792	\$ 1828	\$ 1863	\$ 1899	\$ 1933	\$ 1968	\$ 2004
FWW-MHANO	\$ 1423	\$ 1451	\$ 1479	\$ 1508	\$ 1544	\$ 1578	\$ 1614	\$ 1649	\$ 1685	\$ 1720	\$ 1756	\$ 1790	\$ 1825	\$ 1861
FWS-MHHNO	\$ 1960	\$ 1988	\$ 2016	\$ 2045	\$ 2081	\$ 2115	\$ 2151	\$ 2186	\$ 2222	\$ 2257	\$ 2293	\$ 2327	\$ 2362	\$ 2398
FWS-MHFNO	\$ 1924	\$ 1952	\$ 1980	\$ 2009	\$ 2045	\$ 2079	\$ 2115	\$ 2150	\$ 2186	\$ 2221	\$ 2257	\$ 2291	\$ 2326	\$ 2362
FWS-MHANO	\$ 1781	\$ 1809	\$ 1837	\$ 1866	\$ 1902	\$ 1936	\$ 1972	\$ 2007	\$ 2043	\$ 2078	\$ 2114	\$ 2148	\$ 2183	\$ 2219

Seating

Fabric Grades 9-22 Pricing

GSA SIN 33721

Model Number	Grade 9	Grade 10	Grade 11	Grade 12	Grade 13	Grade 14	Grade 15	Grade 16	Grade 17	Grade 18	Grade 19	Grade 20	Grade 21	Grade 22
RELATE — Pages 118-123														
RL-MHP	\$ 2475	\$ 2505	\$ 2537	\$ 2585	\$ 2637	\$ 2684	\$ 2734	\$ 2787	\$ 2834	\$ 2886	\$ 2933	\$ 2986	\$ 3036	\$ 3084
RL-UHP	\$ 2628	\$ 2686	\$ 2744	\$ 2826	\$ 2904	\$ 2984	\$ 3064	\$ 3144	\$ 3222	\$ 3304	\$ 3383	\$ 3463	\$ 3544	\$ 3622
RL-MHA	\$ 2181	\$ 2211	\$ 2243	\$ 2291	\$ 2343	\$ 2390	\$ 2440	\$ 2493	\$ 2540	\$ 2592	\$ 2639	\$ 2692	\$ 2742	\$ 2790
RL-UHA	\$ 2333	\$ 2391	\$ 2449	\$ 2531	\$ 2609	\$ 2689	\$ 2769	\$ 2849	\$ 2927	\$ 3009	\$ 3088	\$ 3168	\$ 3249	\$ 3327
RELATE ALUMINUM — Pages 118-123														
RLA-MHP	\$ 2878	\$ 2908	\$ 2940	\$ 2988	\$ 3040	\$ 3087	\$ 3137	\$ 3190	\$ 3237	\$ 3289	\$ 3336	\$ 3389	\$ 3439	\$ 3487
RLA-UHP	\$ 3031	\$ 3089	\$ 3147	\$ 3229	\$ 3307	\$ 3387	\$ 3467	\$ 3547	\$ 3625	\$ 3707	\$ 3786	\$ 3866	\$ 3947	\$ 4025
RLA-MHA	\$ 2583	\$ 2613	\$ 2645	\$ 2693	\$ 2745	\$ 2792	\$ 2842	\$ 2895	\$ 2942	\$ 2994	\$ 3041	\$ 3094	\$ 3144	\$ 3192
RLA-UHA	\$ 2738	\$ 2796	\$ 2854	\$ 2936	\$ 3014	\$ 3094	\$ 3174	\$ 3254	\$ 3332	\$ 3414	\$ 3493	\$ 3573	\$ 3654	\$ 3732
RELATE WORK STOOL — Pages 124-127														
RLS-MHP	\$ 3207	\$ 3237	\$ 3269	\$ 3317	\$ 3369	\$ 3416	\$ 3466	\$ 3519	\$ 3566	\$ 3618	\$ 3665	\$ 3718	\$ 3768	\$ 3816
RLS-MHA	\$ 2913	\$ 2943	\$ 2975	\$ 3023	\$ 3075	\$ 3122	\$ 3172	\$ 3225	\$ 3272	\$ 3324	\$ 3371	\$ 3424	\$ 3474	\$ 3522
RELATE SIDE — Pages 128-131														
RLM-MUGO	\$ 1341	\$ 1384	\$ 1425	\$ 1486	\$ 1543	\$ 1603	\$ 1662	\$ 1720	\$ 1780	\$ 1839	\$ 1898	\$ 1956	\$ 2015	\$ 2076
RLM-UUGO	\$ 1441	\$ 1494	\$ 1550	\$ 1637	\$ 1725	\$ 1812	\$ 1899	\$ 1988	\$ 2074	\$ 2162	\$ 2248	\$ 2336	\$ 2424	\$ 2511
RLM-MUGA	\$ 1275	\$ 1318	\$ 1359	\$ 1420	\$ 1477	\$ 1537	\$ 1596	\$ 1654	\$ 1714	\$ 1773	\$ 1832	\$ 1890	\$ 1949	\$ 2010
RLM-UUGA	\$ 1377	\$ 1430	\$ 1488	\$ 1575	\$ 1664	\$ 1753	\$ 1842	\$ 1930	\$ 2019	\$ 2108	\$ 2196	\$ 2285	\$ 2373	\$ 2461
RLM-MUCO	\$ 1433	\$ 1476	\$ 1517	\$ 1578	\$ 1635	\$ 1695	\$ 1754	\$ 1812	\$ 1872	\$ 1931	\$ 1990	\$ 2048	\$ 2107	\$ 2168
RLM-UUCO	\$ 1530	\$ 1583	\$ 1638	\$ 1725	\$ 1813	\$ 1899	\$ 1987	\$ 2074	\$ 2162	\$ 2250	\$ 2336	\$ 2424	\$ 2510	\$ 2599
RLM-MUCA	\$ 1365	\$ 1408	\$ 1449	\$ 1510	\$ 1567	\$ 1627	\$ 1686	\$ 1744	\$ 1804	\$ 1863	\$ 1922	\$ 1980	\$ 2039	\$ 2100
RLM-UUCA	\$ 1465	\$ 1518	\$ 1575	\$ 1662	\$ 1750	\$ 1837	\$ 1924	\$ 2013	\$ 2099	\$ 2187	\$ 2273	\$ 2361	\$ 2449	\$ 2536
RELATE FOUR-LEGGED STOOL — Pages 132-133														
RLC-MUGO	\$ 1847	\$ 1890	\$ 1931	\$ 1992	\$ 2049	\$ 2109	\$ 2168	\$ 2226	\$ 2286	\$ 2345	\$ 2404	\$ 2462	\$ 2521	\$ 2582
RLC-UUGO	\$ 1936	\$ 1987	\$ 2041	\$ 2127	\$ 2211	\$ 2297	\$ 2382	\$ 2467	\$ 2550	\$ 2636	\$ 2721	\$ 2804	\$ 2889	\$ 2976
RLC-MUGA	\$ 1782	\$ 1825	\$ 1866	\$ 1927	\$ 1984	\$ 2044	\$ 2103	\$ 2161	\$ 2221	\$ 2280	\$ 2339	\$ 2397	\$ 2456	\$ 2517
RLC-UUGA	\$ 1870	\$ 1922	\$ 1975	\$ 2061	\$ 2145	\$ 2231	\$ 2316	\$ 2402	\$ 2484	\$ 2570	\$ 2655	\$ 2740	\$ 2824	\$ 2910
RLC-WUGA	\$ 1826	\$ 1869	\$ 1910	\$ 1971	\$ 2028	\$ 2088	\$ 2147	\$ 2205	\$ 2265	\$ 2324	\$ 2383	\$ 2441	\$ 2500	\$ 2561
SEEK — Pages 134-137														
K-MUGO	\$ 1453	\$ 1476	\$ 1500	\$ 1530	\$ 1561	\$ 1591	\$ 1620	\$ 1651	\$ 1680	\$ 1710	\$ 1740	\$ 1770	\$ 1801	\$ 1831
K-MUCO	\$ 1476	\$ 1499	\$ 1523	\$ 1553	\$ 1584	\$ 1614	\$ 1643	\$ 1674	\$ 1703	\$ 1733	\$ 1763	\$ 1793	\$ 1824	\$ 1854
K-MUGA	\$ 1396	\$ 1419	\$ 1443	\$ 1473	\$ 1504	\$ 1534	\$ 1563	\$ 1594	\$ 1623	\$ 1653	\$ 1683	\$ 1713	\$ 1744	\$ 1774
K-MUCA	\$ 1422	\$ 1445	\$ 1469	\$ 1499	\$ 1530	\$ 1560	\$ 1589	\$ 1620	\$ 1649	\$ 1679	\$ 1709	\$ 1739	\$ 1770	\$ 1800
K-PUGO	\$ 1236	\$ 1259	\$ 1283	\$ 1313	\$ 1344	\$ 1374	\$ 1403	\$ 1434	\$ 1463	\$ 1493	\$ 1523	\$ 1553	\$ 1584	\$ 1614
K-PUCO	\$ 1260	\$ 1283	\$ 1307	\$ 1337	\$ 1368	\$ 1398	\$ 1427	\$ 1458	\$ 1487	\$ 1517	\$ 1547	\$ 1577	\$ 1608	\$ 1638
K-PUGA	\$ 1182	\$ 1205	\$ 1229	\$ 1259	\$ 1290	\$ 1320	\$ 1349	\$ 1380	\$ 1409	\$ 1439	\$ 1469	\$ 1499	\$ 1530	\$ 1560
K-PUCA	\$ 1204	\$ 1227	\$ 1251	\$ 1281	\$ 1312	\$ 1342	\$ 1371	\$ 1402	\$ 1431	\$ 1461	\$ 1491	\$ 1521	\$ 1552	\$ 1582
SVELTE — Pages 139-141														
SV2HPNO	\$ 1730	\$ 1778	\$ 1827	\$ 1875	\$ 1936	\$ 1997	\$ 2056	\$ 2117	\$ 2178	\$ 2239	\$ 2300	\$ 2360	\$ 2421	\$ 2482
SV2HCNO	\$ 1972	\$ 2020	\$ 2069	\$ 2117	\$ 2178	\$ 2239	\$ 2298	\$ 2359	\$ 2420	\$ 2481	\$ 2542	\$ 2602	\$ 2663	\$ 2724
SV2MPNO	\$ 1691	\$ 1739	\$ 1788	\$ 1836	\$ 1897	\$ 1958	\$ 2017	\$ 2078	\$ 2139	\$ 2200	\$ 2261	\$ 2321	\$ 2382	\$ 2443
SV2MCNO	\$ 1932	\$ 1980	\$ 2029	\$ 2077	\$ 2138	\$ 2199	\$ 2258	\$ 2319	\$ 2380	\$ 2441	\$ 2502	\$ 2562	\$ 2623	\$ 2684

Social Collaborative is Allsteel's answer for teaming spaces, areas outside of the primary workstation where workers can go to collaborate and be productive.

Jetty:Mod™ pages 165-200

Seating & Ottomans

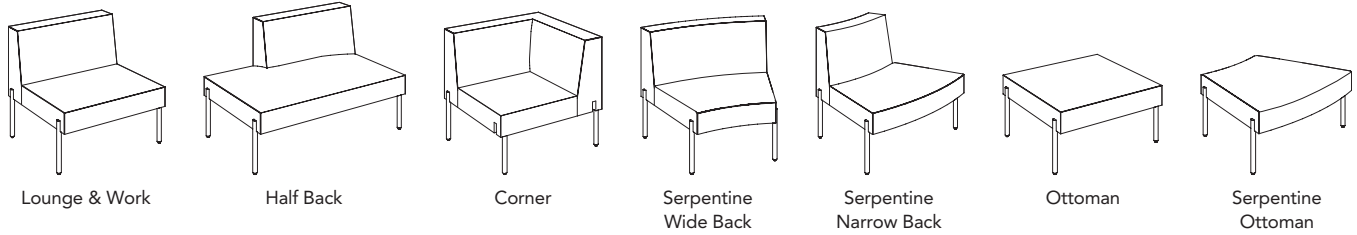

Arms & Endcaps

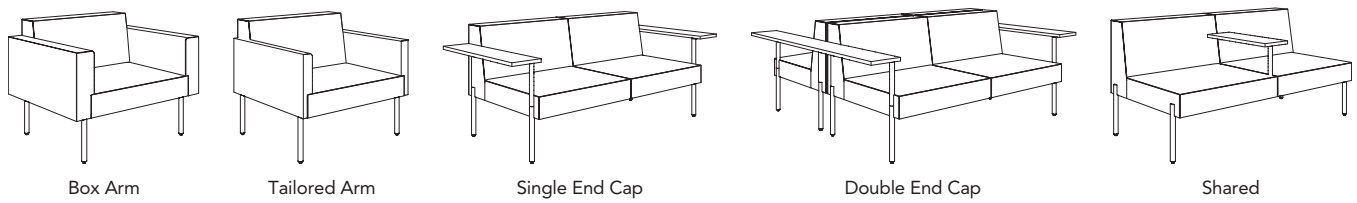

Tables

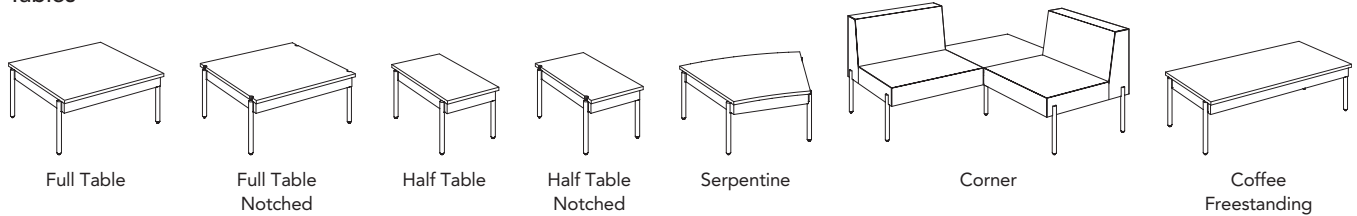

Screens

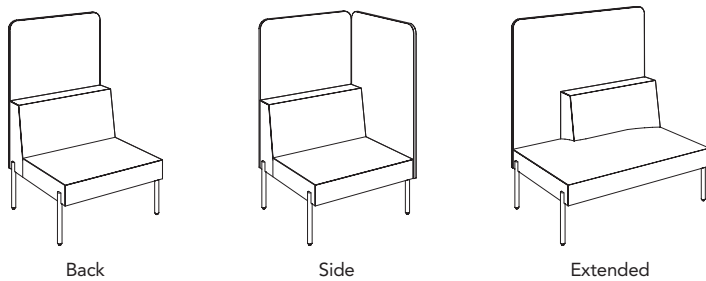

Accessories

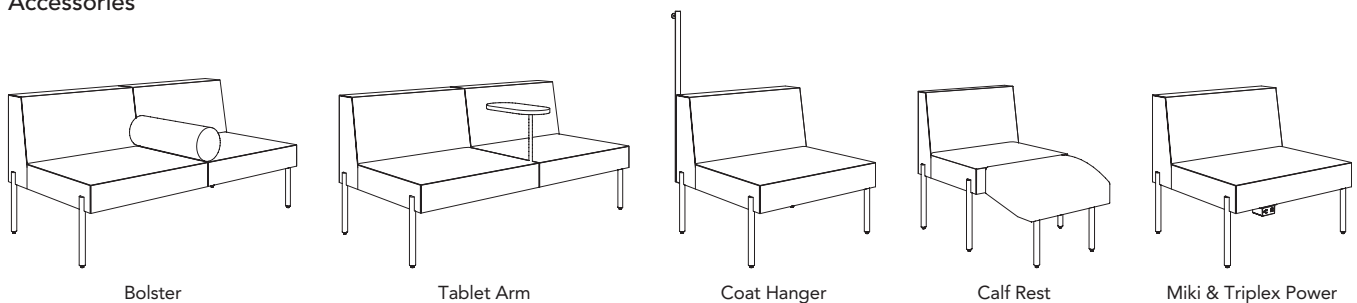

NOTE: All options shown in the statement of line are available on lounge (30 x 30) and work (24 x 24) models

Townhall™ Peak™ page 204

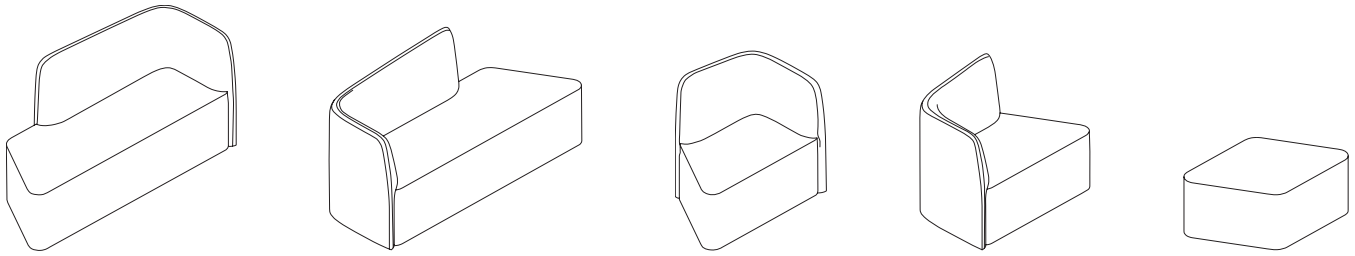

Townhall™ Cloud™ page 207

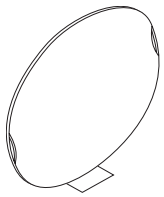

Townhall™ Rock™ pages 208-209

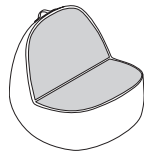

Townhall™ Wedge™ pages 210-211

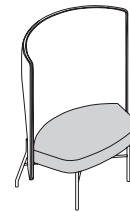

Townhall™ Picnic™ pages 212-213

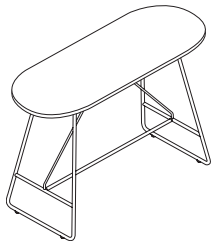

Townhall™ Summit™ page 214



Park™ by Norm Architects pages 215-226

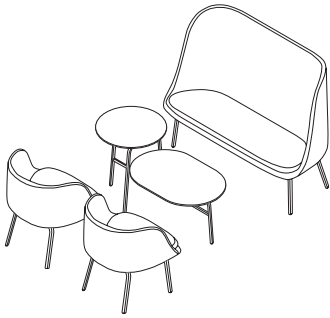

Recharge pages 227-243

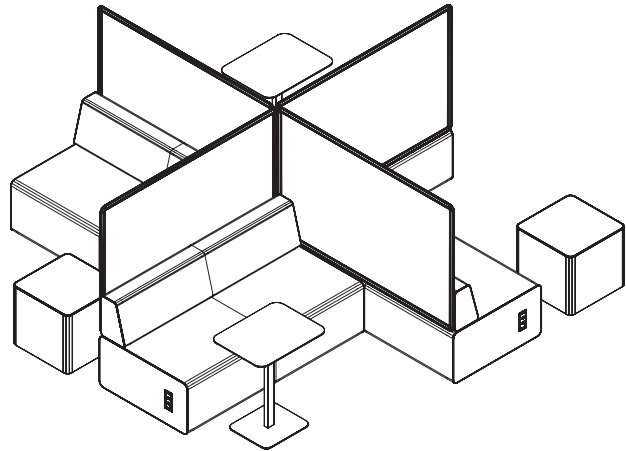

Rise™ pages 244-258

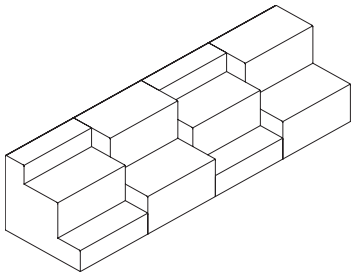

Retreat™ Lounge pages 262-265

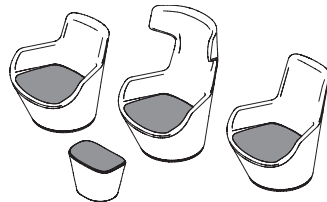

Retreat™ Executive / Conference
pages 266-267



Parallel™ pages 268-276

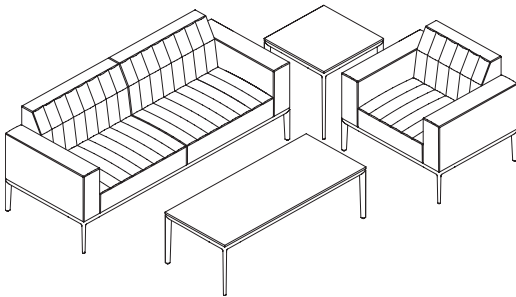

Two Thirds pages 278-289

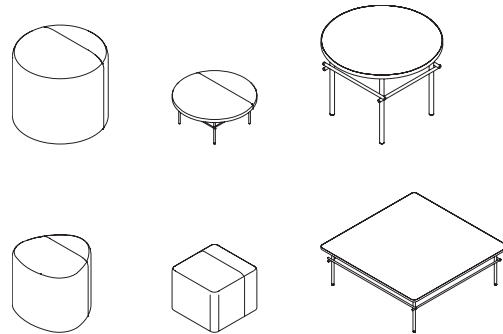

Vicinity™ Lounge pages [290-293](#)



Co|Ho™ pages [294-295](#)



Linger™ pages [296-299](#)



Reflect™ pages [300-303](#)

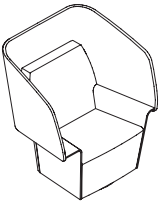

Clubhouse™ pages [304-317](#)

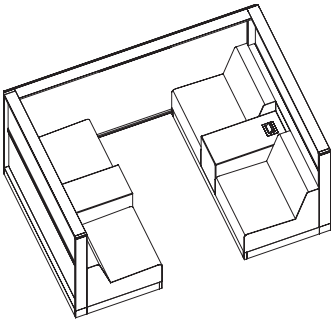

Involve® for additional soft seating —
see Casegoods & Storage Price List pages [285-286](#)

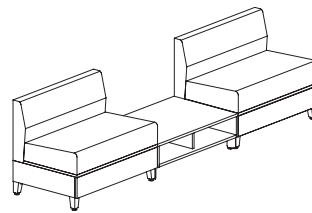

Seating

- Available upholstery option
- RR: railroaded, F/FR: Fire compliant model

UPHOLSTERY

Pattern Name	Code	Supplier	Grade		Clubhouse - Front Board/Back Board/Storage	Clubhouse - Seating/ Consoles	Hedge - no CAL 133	Jetty/Mod	Linger Seat	Linger Side	Parallel	Park Collection Seat MDS 10272	Park Collection Shell MDS 10272
Parker	1054	HBF Textiles	3	•	•	•	•	•	•	•	•	•	•
Blink	1048	HBF Textiles	4	F	F	•	•	F	F	F	F	F	F
Look-See	1044	HBF Textiles	4	F	F	F	•	F	F	F	F	F	F
Walkabout	1046	HBF Textiles	4	F	F	•	•	F	F	F	F	•	•
Against the Grain	AGG	HBF Textiles	5	•	•	F	•	F	F	F	F	•	•
Caddy Corner	1016	HBF Textiles	5	•	•	•	•	•	•	•	•	•	•
Checkmate	1043	HBF Textiles	5	F	F	•	•	F	F	F	F	•	•
Pebbled	SHBFPEB	HBF Textiles	5	•	•	•	•	•	•	•	•	•	•
Picnic Plaid	1029	HBF Textiles	5	•	•	•	•	•	•	•	•	•	•
Upbeat	1036	HBF Textiles	5	•	•	•	•	•	•	•	•	•	•
Zippy	1045	HBF Textiles	5	F	F	•	•	F	F	F	F	•	•
Poppy	1047	HBF Textiles	6	F	F	•	•	F	F	F	F	•	•
Crew Cut	SHBFCRW	HBF Textiles	7	•	•	•	•	•	•	•	•	•	•
Happy Camper	1028	HBF Textiles	7	•	•	•	•	•	•	•	•	•	•
Honest	SHBFHON	HBF Textiles	7	•	•	•	•	•	•	•	•	•	•
Roundabout	1005	HBF Textiles	7	•	•	•	•	•	•	•	•	•	•
Beetle	SHBFBEE	HBF Textiles	8	•	•	•	•	•	•	•	•	•	•
Dashing	1008	HBF Textiles	8	•	•	•	•	•	•	•	•	•	•
Fourfold	SHBFFOU	HBF Textiles	8	•	•	•	•	•	•	•	•	•	•
Modern Tweed	SHBFMOD	HBF Textiles	8	•	•	•	•	•	•	•	•	•	•
Sherpa	1031	HBF Textiles	8	•	•	•	•	•	•	•	•	•	•
All Terrain	1027	HBF Textiles	9	•	•	•	•	•	•	•	•	•	•
Comfort Zone	905	HBF Textiles	9	•	•	•	•	•	•	•	•	•	•
Crafted Felt	1017	HBF Textiles	9	•	•	•	•	•	•	•	•	•	•
Curtain Wall	1023	HBF Textiles	9	•	•	•	•	•	•	•	•	•	•
High Rise	SHBFHIG	HBF Textiles	9	•	•	F	•	•	•	F	•	•	•
Madam Dottie	1001	HBF Textiles	9	•	•	•	•	•	•	•	•	•	•
Scribble XS	982	HBF Textiles	9	•	•	•	•	•	•	•	•	•	•
Uptown	1039	HBF Textiles	9	•	•	•	•	•	•	•	•	•	•
Wabi Sabi	SHBFWAB	HBF Textiles	9	•	•	•	•	•	•	•	•	•	•
Color Code	998	HBF Textiles	10	•	•	•	•	•	•	•	•	•	•
Digital Bloom 2.0	1050	HBF Textiles	10	•	•	•	•	•	•	•	•	•	•
Equation	SHBFEQU	HBF Textiles	10	•	•	F	•	F	F	F	F	•	•
Folded Lines	973	HBF Textiles	10	•	•	•	•	•	•	•	•	•	•
Remember	SHBFREM	HBF Textiles	10	•	•	•	•	•	•	•	•	•	•
Roy's Cords	1025	HBF Textiles	10	•	•	•	•	•	•	•	•	•	•
Soft Angles 2.0	1051	HBF Textiles	10	•	•	•	•	•	•	•	•	•	•
Upscale	1040	HBF Textiles	10	•	•	•	•	•	•	•	•	•	•
Air Mail	1006	HBF Textiles	11	•	•	•	•	•	•	•	•	•	•
Argyle Boucle	978	HBF Textiles	11	•	•	•	•	•	•	•	•	•	•
Brushed Canvas	SHBFBCV	HBF Textiles	11	•	•	•	•	•	•	•	•	•	•
Cloud	SHBFCLD	HBF Textiles	11	•	•	•	•	•	•	•	•	•	•
Abito	ABI	HBF Textiles	12	•	•	F	•	F	F	F	•	•	•
Belgian Meadow	SHBFBLM	HBF Textiles	12	•	•	•	•	•	•	•	•	•	•
Complex	964	HBF Textiles	12	•	•	•	•	•	•	•	•	•	•
Crosstweed	991	HBF Textiles	12	•	•	•	•	•	•	•	•	•	•
Cutout	SHBFCUT	HBF Textiles	12	•	•	•	•	•	•	•	•	•	•
Dot Grid	975	HBF Textiles	12	•	•	•	•	•	•	•	•	•	•
Dot Structure	SHBFDOT	HBF Textiles	12	•	•	•	•	•	•	•	•	•	•
Glint	SHBFGLT	HBF Textiles	12	•	•	•	•	•	•	•	•	•	•
Grateful Grid	1015	HBF Textiles	12	•	•	•	•	•	•	•	•	•	•
Heartfelt	SHBFHTF	HBF Textiles	12	F	F	•	•	F	F	F	•	•	•
Lava Rock	993	HBF Textiles	12	•	•	•	•	•	•	•	•	•	•
Merci Boucle	SHBFMER	HBF Textiles	12	•	•	•	•	•	•	•	•	•	•
Moving Blanket	SHBFMOV	HBF Textiles	12	•	•	•	•	•	•	•	•	•	•
Sable Island	SHBFSAB	HBF Textiles	12	•	•	•	•	•	•	•	•	•	•
Sir Stripe A Lot	1004	HBF Textiles	12	•	•	•	•	•	•	•	•	•	•

Seating

- Available upholstery option
- RR: railroaded, F/FR: Fire compliant model

Pattern Name	Code	Supplier	Grade	Clubhouse - Front Board/Back Board/Storage	Clubhouse - Seating/ Consoles	Hedge - no CAL 133	Jetty/Mod	Linger Seat	Linger Side	Parallel	Park Collection Seat MDS 10272	Park Collection Shell MDS 10272
Sweater Weather	1030	HBF Textiles	12	•	•	•	•	•	•	•	•	•
Twist	SHBFTWS	HBF Textiles	12	•	•	•	•	•	•	•	•	•
Upstart	1042	HBF Textiles	12	•	•	•	•	•	•	•	•	•
Cherished Knit	954	HBF Textiles	13	•	•	•	•	•	•	•	•	•
Enriched Boucle	1021	HBF Textiles	13	•	•	•	•	•	•	•	•	•
Foundation	SHBFFND	HBF Textiles	13	•	•	•	•	•	•	•	•	•
Moving Forward	1014	HBF Textiles	13	•	•	•	•	•	•	•	•	•
Night Earth	1013	HBF Textiles	13	•	•	•	•	•	•	•	•	•
Pepper Blend	995	HBF Textiles	13	•	•	•	•	•	•	•	•	•
Quill	1011	HBF Textiles	13	•	•	•	•	•	•	•	•	•
Scribble XL	983	HBF Textiles	13	•	•	•	•	•	•	•	•	•
Sister Solid	1003	HBF Textiles	13	•	•	•	•	•	•	•	•	•
Afghan	AFG	HBF Textiles	14	•	•	•	•	•	•	•	•	•
Smart	SHBFSMT	HBF Textiles	14	•	•	•	•	•	•	•	•	•
Velvet Mix	977	HBF Textiles	14	•	•	•	•	•	•	•	•	•
Hipster	SHBFHPT	HBF Textiles	15	•	•	•	•	•	•	•	•	•
Landscape Blur	1024	HBF Textiles	15	•	•	•	•	•	•	•	•	•
Poodle	1009	HBF Textiles	16	•	•	•	•	•	•	•	•	•
Sweater	SHBFSWE	HBF Textiles	16	•	•	•	•	•	•	•	•	•
Woven Memory	1019	HBF Textiles	16	•	•	•	•	•	•	•	•	•
Crafted Cloud	1018	HBF Textiles	19	•	•	•	•	•	•	•	•	•
Knitwork	SHBFKNI	HBF Textiles	21	•	•	•	•	•	•	•	•	•
Bunny	1012	HBF Textiles	23	•	•	•	•	•	•	•	•	•
Eccentric	966	HBF Textiles	23	•	•	•	•	•	•	•	•	•
Eccentric	SHBFEC	HBF Textiles	23	•	•	•	•	•	•	•	•	•
Wild West	717	HBF Textiles	L2	•	•	•	•	•	•	•	•	•
Aviator	SHBFAVI	HBF Textiles	L3	•	•	•	•	•	•	•	•	•
Free Way	SHBFFRE	HBF Textiles	L3	•	•	•	•	F	F	•	•	•
Modern Patina	716	HBF Textiles	L3	•	•	•	•	•	•	•	•	•
Persuede	718	HBF Textiles	L3	•	•	•	•	•	•	•	•	•
Vivace II	709	HBF Textiles	L3	•	•	•	•	•	•	•	•	•
Upper Crust	708	HBF Textiles	L5	•	•	•	•	•	•	•	•	•
Voyage	713	HBF Textiles	L5	•	•	•	•	•	•	•	•	•

UPHOLSTERY

Seating

- Available upholstery option
- RR: railroaded, F/FR: Fire compliant model

UPHOLSTERY

Pattern Name	Code	Supplier	Grade	Peak Back MDS 10269	Peak Seat MDS 10269	Peak Single Upholstery MDS 10269	Peak Welt MDS 10269	Peak Ottoman MDS 10269	Picnic Upholstered Seating MDS 10269	Recharge Pouf - Seat, Side, Welt	Recharge Bolster	Recharge Bolster Welt	Recharge Seat - NO RR	Reflect Seat (Seat and Back)
Parker	1054	HBF Textiles	3	•	•	•	•	•	•	•	•	•	•	•
Blink	1048	HBF Textiles	4		F		F	F	F	F	F	F	F	F
Look-See	1044	HBF Textiles	4	F	F	F	F	F	F	F	F	F	F	F
Walkabout	1046	HBF Textiles	4		•		•	•	•	•	•	•	•	•
Against the Grain	AGG	HBF Textiles	5		•		•	•	•	•	•	•	•	•
Caddy Corner	1016	HBF Textiles	5	•	•	•	•	•	•	•	•	•	•	•
Checkmate	1043	HBF Textiles	5	•	•	•	•	•	•	F	F	F	F	F
Pebbled	SHBFPEB	HBF Textiles	5	•	•	•	•	•	•	•	•	•	•	•
Picnic Plaid	1029	HBF Textiles	5	•	•	•	•	•	•	•	•	•	•	•
Upbeat	1036	HBF Textiles	5	•	•	•	•	•	•	•	•	•	•	•
Zippy	1045	HBF Textiles	5	•	•	•	•	•	•	•	•	•	•	•
Poppy	1047	HBF Textiles	6	•	•	•	•	•	•	F	F	F	F	F
Crew Cut	SHBFCRW	HBF Textiles	7	•	•	•	•	•	•	•	•	•	•	•
Happy Camper	1028	HBF Textiles	7	•	•	•	•	•	•	•	•	•	•	•
Honest	SHBFHON	HBF Textiles	7	•	•	•	•	•	•	•	•	•	•	•
Roundabout	1005	HBF Textiles	7		•		•	•	•	•	•	•	•	•
Beetle	SHBFBEE	HBF Textiles	8		•		•	•	•	•	•	•	•	•
Dashing	1008	HBF Textiles	8	•	•	•	•	•	•	•	•	•	•	•
Fourfold	SHBFFOU	HBF Textiles	8						•	•	•	•	•	•
Modern Tweed	SHBFMOD	HBF Textiles	8		•		•	•	•	•	•	•	•	•
Sherpa	1031	HBF Textiles	8	•	•	•	•	•	•	•	•	•	•	•
All Terrain	1027	HBF Textiles	9	•	•	•	•	•	•	•	•	•	•	•
Comfort Zone	905	HBF Textiles	9	•	•	•	•	•	•	•	•	•	•	•
Crafted Felt	1017	HBF Textiles	9	•	•	•	•	•	•	•	•	•	•	•
Curtain Wall	1023	HBF Textiles	9	•	•	•	•	•	•	•	•	•	•	•
High Rise	SHBFHIG	HBF Textiles	9		•		•	•	•	•				•
Madam Dottie	1001	HBF Textiles	9	•	•	•	•	•	•	•	•	•	•	•
Scribble XS	982	HBF Textiles	9	•	•	•	•	•	•	•	•	•	•	•
Uptown	1039	HBF Textiles	9	•	•	•	•	•	•	•	•	•	•	•
Wabi Sabi	SHBFWAB	HBF Textiles	9		•		•	•	•	•				•
Color Code	998	HBF Textiles	10	•	•	•	•	•	•	•	•	•	•	•
Digital Bloom 2.0	1050	HBF Textiles	10	•	•	•	•	•	•	•	•	•	•	•
Equation	SHBFEQU	HBF Textiles	10		•		•	•	•	•	•	•	•	•
Folded Lines	973	HBF Textiles	10	•	•	•	•	•	•	•	•	•	•	•
Remember	SHBFREM	HBF Textiles	10		•		•	•	•	•	•	•	•	•
Roy's Cords	1025	HBF Textiles	10		•		•	•	•	•	•	•	•	•
Soft Angles 2.0	1051	HBF Textiles	10	•	•	•	•	•	•	•	•	•	•	•
Upscale	1040	HBF Textiles	10	•	•	•	•	•	•	•	•	•	•	•
Air Mail	1006	HBF Textiles	11	•	•	•	•	•	•	•	•	•	•	•
Argyle Boucle	978	HBF Textiles	11	•	•	•	•	•	•	•	•	•	•	•
Brushed Canvas	SHBFBCV	HBF Textiles	11	•	•	•	•	•	•	•	•	•	•	•
Cloud	SHBFCLD	HBF Textiles	11		•		•	•	•					•
Abito	ABI	HBF Textiles	12		•		•	•	•	•	•	•	•	•
Belgian Meadow	SHBFBLM	HBF Textiles	12	•	•	•	•	•	•	•	•	•	•	•
Complex	964	HBF Textiles	12	•	•	•	•	•	•	•	•	•	•	•
Crosstweed	991	HBF Textiles	12	•	•	•	•	•	•	•	•	•	•	•
Cutout	SHBFCUT	HBF Textiles	12		•		•	•	•	•	•	•	•	•
Dot Grid	975	HBF Textiles	12	•	•	•	•	•	•	•	•	•	•	•
Dot Structure	SHBFDOT	HBF Textiles	12	•	•	•	•	•	•	•	•	•	•	•
Glint	SHBFGLT	HBF Textiles	12		•		•	•	•					•
Grateful Grid	1015	HBF Textiles	12	•	•	•	•	•	•	•	•	•	•	•
Heartfelt	SHBFHTF	HBF Textiles	12	•	•	•	•	•	•	•	•	•	•	•
Lava Rock	993	HBF Textiles	12	•	•	•	•	•	•	•	•	•	•	•
Merci Boucle	SHBFMER	HBF Textiles	12	•	•	•	•	•	•	•	•	•	•	•
Moving Blanket	SHBFMOV	HBF Textiles	12		•		•	•	•	•	•	•	•	•
Sable Island	SHBFSAB	HBF Textiles	12		•		•	•	•	•	•	•	•	•
Sir Stripe A Lot	1004	HBF Textiles	12	•	•	•	•	•	•	•	•	•	•	•

Seating

- Available upholstery option
- RR: railroaded, F/FR: Fire compliant model

Pattern Name	Code	Supplier	Grade	Peak Back MDS 10269	Peak Seat MDS 10269	Peak Single Upholstery MDS 10269	Peak Welt MDS 10269	Peak Ottoman MDS 10269	Picnic Upholstered Seating MDS 10269	Recharge Pouf - Seat, Side, Welt	Recharge Bolster	Recharge Bolster Welt	Recharge Seat - NO RR	Reflect Seat (Seat and Back)
Sweater Weather	1030	HBF Textiles	12	•	•	•	•	•	•	•	•	•	•	•
Twist	SHBFTWS	HBF Textiles	12	•	•	•	•	•	•	•	•	•	•	•
Upstart	1042	HBF Textiles	12	•	•	•	•	•	•	•	•	•	•	•
Cherished Knit	954	HBF Textiles	13	•	•	•	•	•	•	•	•	•	•	•
Enriched Boucle	1021	HBF Textiles	13	•	•	•	•	•	•	•	•	•	•	•
Foundation	SHBFFND	HBF Textiles	13	•	•	•	•	•	•	•	•	•	•	•
Moving Forward	1014	HBF Textiles	13	•	•	•	•	•	•	•	•	•	•	•
Night Earth	1013	HBF Textiles	13	•	•	•	•	•	•	•	•	•	•	•
Pepper Blend	995	HBF Textiles	13	•	•	•	•	•	•	•	•	•	•	•
Quill	1011	HBF Textiles	13	•	•	•	•	•	•	•	•	•	•	•
Scribble XL	983	HBF Textiles	13	•	•	•	•	•	•	•	•	•	•	•
Sister Solid	1003	HBF Textiles	13	•	•	•	•	•	•	•	•	•	•	•
Afghan	AFG	HBF Textiles	14	•	•	•	•	•	•	•	•	•	•	•
Smart	SHBFSMT	HBF Textiles	14	•	•	•	•	•	•	•	•	•	•	•
Velvet Mix	977	HBF Textiles	14	•	•	•	•	•	•	•	•	•	•	•
Hipster	SHBFHPT	HBF Textiles	15	•	•	•	•	•	•	•	•	•	•	•
Landscape Blur	1024	HBF Textiles	15	•	•	•	•	•	•	•	•	•	•	•
Poodle	1009	HBF Textiles	16	•	•	•	•	•	•	•	•	•	•	•
Sweater	SHBFSWE	HBF Textiles	16	•	•	•	•	•	•	•	•	•	•	•
Woven Memory	1019	HBF Textiles	16	•	•	•	•	•	•	•	•	•	•	•
Crafted Cloud	1018	HBF Textiles	19	•	•	•	•	•	•	•	•	•	•	•
Knitwork	SHBFKNI	HBF Textiles	21	•	•	•	•	•	•	•	•	•	•	•
Bunny	1012	HBF Textiles	23	•	•	•	•	•	•	•	•	•	•	•
Eccentric	966	HBF Textiles	23	•	•	•	•	•	•	•	•	•	•	•
Eccentric	SHBFEC	HBF Textiles	23	•	•	•	•	•	•	•	•	•	•	•
Wild West	717	HBF Textiles	L2	•	•	•	•	•	•	•	•	•	•	•
Aviator	SHBFAVI	HBF Textiles	L3											
Free Way	SHBFFRE	HBF Textiles	L3											
Modern Patina	716	HBF Textiles	L3	•	•	•	•	•	•	•	•	•	•	•
Persuede	718	HBF Textiles	L3	•	•	•	•	•	•	•	•	•	•	•
Vivace II	709	HBF Textiles	L3											
Upper Crust	708	HBF Textiles	L5											
Voyage	713	HBF Textiles	L5											

UPHOLSTERY

Seating

- Available upholstery option
- RR: railroaded, F/FR: Fire compliant model

UPHOLSTERY

Pattern Name	Code	Supplier	Grade	Reflect Shell	Retreat Executive Conference Seat	Retreat Executive Conference Back/ Full Pass (10281)	Retreat Hi/Low/Ottoman Top/Seat	Retreat Hi/Low/Ottoman Side/Body	Retreat WingBack Seat	Retreat WingBack Body	Retreat Hi/Low/Ott LEATHER	Rise Seat	Rise Side	Rise Single Upholstery
Parker	1054	HBF Textiles	3		•	•	•	•						
Blink	1048	HBF Textiles	4	F		F		F					F	
Look-See	1044	HBF Textiles	4	F	F	F	F	F					F	
Walkabout	1046	HBF Textiles	4	•	•	•	•	•					F	
Against the Grain	AGG	HBF Textiles	5		•	•	•	•				F	F	•
Caddy Corner	1016	HBF Textiles	5	•	•	•	•	•	•				•	•
Checkmate	1043	HBF Textiles	5	F	•	•	•	•	•			F	F	•
Pebbled	SHBFPEB	HBF Textiles	5	•	•	•		•				•	•	•
Picnic Plaid	1029	HBF Textiles	5	•	•		•	•					•	
Upbeat	1036	HBF Textiles	5	•	•		•	•						
Zippy	1045	HBF Textiles	5		•	•	•	•				F	F	F
Poppy	1047	HBF Textiles	6		•	•	•	•	•			F	F	•
Crew Cut	SHBFCRW	HBF Textiles	7		•	•	•	•					•	
Happy Camper	1028	HBF Textiles	7	•	•	•	•	•	•				•	
Honest	SHBFHON	HBF Textiles	7		•	•	•	•				•	•	•
Roundabout	1005	HBF Textiles	7		•		•	•					•	
Beetle	SHBFBEE	HBF Textiles	8		•	•	•	•					•	
Dashing	1008	HBF Textiles	8		•		•	•					•	
Fourfold	SHBFFOU	HBF Textiles	8		•		•	•					•	
Modern Tweed	SHBFMOD	HBF Textiles	8		•		•	•				•	•	•
Sherpa	1031	HBF Textiles	8		•	•	•	•					•	
All Terrain	1027	HBF Textiles	9	•	•	•	•	•				•	•	•
Comfort Zone	905	HBF Textiles	9		•		•	•					•	
Crafted Felt	1017	HBF Textiles	9	•	•	•	•	•	•			•	•	•
Curtain Wall	1023	HBF Textiles	9		•		•	•					•	
High Rise	SHBFHIG	HBF Textiles	9		•		•	•				•	F	
Madam Dottie	1001	HBF Textiles	9	•	•	•	•	•				•	•	•
Scribble XS	982	HBF Textiles	9		•		•	•				•	•	•
Uptown	1039	HBF Textiles	9	•	•		•	•					•	
Wabi Sabi	SHBFWAB	HBF Textiles	9		•		•	•					•	
Color Code	998	HBF Textiles	10	•	•		•	•					•	
Digital Bloom 2.0	1050	HBF Textiles	10		•		•	•					•	
Equation	SHBFEQU	HBF Textiles	10		•		•	•				F	F	•
Folded Lines	973	HBF Textiles	10	•	•		•	•					•	
Remember	SHBFREM	HBF Textiles	10		•		•	•					•	
Roy's Cords	1025	HBF Textiles	10	•	•		•	•					•	
Soft Angles 2.0	1051	HBF Textiles	10	•	•	•	•	•	•				•	
Upscale	1040	HBF Textiles	10		•		•	•					•	
Air Mail	1006	HBF Textiles	11	•	•		•	•				•	•	•
Argyle Boucle	978	HBF Textiles	11	•	•	•	•	•	•			•	•	•
Brushed Canvas	SHBFBCV	HBF Textiles	11	•	•	•	•	•	•			•	•	•
Cloud	SHBFCLD	HBF Textiles	11		•		•	•					•	
Abito	ABI	HBF Textiles	12	•	•	•	•	•				F	F	•
Belgian Meadow	SHBFBLM	HBF Textiles	12	•	•	•	•	•	•			•	•	•
Complex	964	HBF Textiles	12	•	•	•	•	•					•	
Crosstweed	991	HBF Textiles	12	•	•	•	•	•	•			•	•	
Cutout	SHBFCUT	HBF Textiles	12		•		•	•					•	
Dot Grid	975	HBF Textiles	12		•		•	•					•	
Dot Structure	SHBFDOT	HBF Textiles	12	•	•	•	•	•	•			•	•	•
Glint	SHBFGLT	HBF Textiles	12		•		•	•						
Grateful Grid	1015	HBF Textiles	12	•	•	•	•	•					•	
Heartfelt	SHBFHTF	HBF Textiles	12	RR F	•	•	F	F	F	F		F	F	•
Lava Rock	993	HBF Textiles	12	•	•	•	•	•	•			•	•	•
Merci Boucle	SHBFMER	HBF Textiles	12	•	•	•	•	•	•			•	•	•
Moving Blanket	SHBFMOV	HBF Textiles	12		•		•	•				•	•	•
Sable Island	SHBFSAB	HBF Textiles	12		•		•	•				•	•	•
Sir Stripe A Lot	1004	HBF Textiles	12		•		•	•				•	•	•

Seating

- Available upholstery option
- RR: railroaded, F/FR: Fire compliant model

Pattern Name	Code	Supplier	Grade	Reflect Shell	Retreat Executive Conference Seat	Retreat Executive Conference Seat Full Pass (10281)	Retreat Hi/Low/Ottoman Back	Retreat Hi/Low/Ottoman Top/Seat	Retreat WingBack Side/Body	Retreat WingBack Seat	Retreat WingBack Body	Retreat Hi/Low/Ott LEATHER	Rise Seat	Rise Side	Rise Single Upholstery
Sweater Weather	1030	HBF Textiles	12	•	•	•	•	•	•	•			•		
Twist	SHBFTWS	HBF Textiles	12	•	•	•	•	•	•	•			•		
Upstart	1042	HBF Textiles	12	•	•	•	•	•	•				•	•	•
Cherished Knit	954	HBF Textiles	13	•	•	•	•	•	•	•			•	•	•
Enriched Boucle	1021	HBF Textiles	13		•	•	•	•	•				•	•	•
Foundation	SHBFFND	HBF Textiles	13	•	•		•		•				•	•	•
Moving Forward	1014	HBF Textiles	13	•	•		•		•				•	•	•
Night Earth	1013	HBF Textiles	13	•	•		•		•				•	•	•
Pepper Blend	995	HBF Textiles	13	•	•		•		•				•	•	•
Quill	1011	HBF Textiles	13	•	•	•	•	•	•				•	•	•
Scribble XL	983	HBF Textiles	13		•		•		•				•	•	•
Sister Solid	1003	HBF Textiles	13	•	•	•	•	•	•	•			•	•	•
Afghan	AFG	HBF Textiles	14	•	•	•	•	•	•	•				•	
Smart	SHBFSMT	HBF Textiles	14		•				•				•	•	•
Velvet Mix	977	HBF Textiles	14		•		•		•					•	
Hipster	SHBFHPT	HBF Textiles	15		•				•					•	
Landscape Blur	1024	HBF Textiles	15		•		•		•					•	
Poodle	1009	HBF Textiles	16	•	•		•		•				•	•	•
Sweater	SHBFSWE	HBF Textiles	16	•	•	•	•	•	•					•	
Woven Memory	1019	HBF Textiles	16		•		•		•					•	
Crafted Cloud	1018	HBF Textiles	19		•		•		•					•	
Knitwork	SHBFKNI	HBF Textiles	21		•	•	•	•	•				•	•	•
Bunny	1012	HBF Textiles	23	•	•	•	•	•	•					•	
Eccentric	966	HBF Textiles	23		•	•	•		•				•	•	•
Eccentric	SHBFEC	HBF Textiles	23		•	•	•		•				•	•	•
Wild West	717	HBF Textiles	L2	•	•		•		•						
Aviator	SHBFAVI	HBF Textiles	L3												
Free Way	SHBFFRE	HBF Textiles	L3												
Modern Patina	716	HBF Textiles	L3	•	•		•		•						
Persuede	718	HBF Textiles	L3	•	•		•		•						
Vivace II	709	HBF Textiles	L3				•	•							
Upper Crust	708	HBF Textiles	L5				•	•							
Voyage	713	HBF Textiles	L5				•	•							

UPHOLSTERY

Seating

- Available upholstery option
- RR: railroaded, F/FR: Fire compliant model

UPHOLSTERY

Pattern Name	Code	Supplier	Grade	Rock - Cushions MDS 10269	Rock - Shell/Body MDS 10269	Rock Single Upholstery MDS 10269	Summit	Two Thirds Pour	Wedge Seat MDS 10269	Wedge Back MDS 10270	Wedge Single Upholstery MDS 10269
Parker	1054	HBF Textiles	3	•	•	•	•	•	•	•	•
Blink	1048	HBF Textiles	4	F				F	F	F	F
Look-See	1044	HBF Textiles	4	F	F	F	F	F	F	F	F
Walkabout	1046	HBF Textiles	4	•				•	•	•	•
Against the Grain	AGG	HBF Textiles	5	•	•	•	•		•	•	•
Caddy Corner	1016	HBF Textiles	5	•	•	•	•	•	•	•	•
Checkmate	1043	HBF Textiles	5	•	•	•	•	•	•	•	•
Pebbled	SHBFPEB	HBF Textiles	5	•	•	•	•	•			
Picnic Plaid	1029	HBF Textiles	5	•			•	•	•		
Upbeat	1036	HBF Textiles	5	•	•	•		•	•	•	•
Zippy	1045	HBF Textiles	5	•				•	•	•	•
Poppy	1047	HBF Textiles	6	•	•	•	F	•	•	•	•
Crew Cut	SHBFCRW	HBF Textiles	7	•				•	•	•	•
Happy Camper	1028	HBF Textiles	7	•	•	•	•	•	•	•	•
Honest	SHBFHON	HBF Textiles	7	•	•	•	•	•			
Roundabout	1005	HBF Textiles	7	•				•	•		
Beetle	SHBFBEE	HBF Textiles	8	•	•	•	•	•	•	•	•
Dashing	1008	HBF Textiles	8	•				•	•		
Fourfold	SHBFFOU	HBF Textiles	8	•				•	•		
Modern Tweed	SHBFMOD	HBF Textiles	8	•				•	•		
Sherpa	1031	HBF Textiles	8	•			•	•	•	•	•
All Terrain	1027	HBF Textiles	9	•	•	•		•			
Comfort Zone	905	HBF Textiles	9	•				•	•		
Crafted Felt	1017	HBF Textiles	9	•	•	•	•	•	•	•	•
Curtain Wall	1023	HBF Textiles	9	•				•	•		
High Rise	SHBFHIG	HBF Textiles	9					•			
Madam Dottie	1001	HBF Textiles	9	•	•	•	•	•	•		
Scribble XS	982	HBF Textiles	9	•				•	•		
Uptown	1039	HBF Textiles	9	•				•	•		
Wabi Sabi	SHBFWAB	HBF Textiles	9	•					•		
Color Code	998	HBF Textiles	10	•			•	•	•		
Digital Bloom 2.0	1050	HBF Textiles	10	•			•	•		•	
Equation	SHBFEQU	HBF Textiles	10	•	•	•	•	•	•	•	•
Folded Lines	973	HBF Textiles	10	•			•	•	•		
Remember	SHBFREM	HBF Textiles	10	•				•	•		
Roy's Cords	1025	HBF Textiles	10	•				•	•		
Soft Angles 2.0	1051	HBF Textiles	10	•				•	•	•	•
Upscale	1040	HBF Textiles	10	•			•	•	•		
Air Mail	1006	HBF Textiles	11	•			•	•	•		
Argyle Boucle	978	HBF Textiles	11	•	•	•	•	•	•		
Brushed Canvas	SHBFBCV	HBF Textiles	11	•	•	•	•	•	•		
Cloud	SHBFCLD	HBF Textiles	11	•				•	•	•	•
Abito	ABI	HBF Textiles	12	•			•	•	•		
Belgian Meadow	SHBFBLM	HBF Textiles	12	•			•	•	•	•	•
Complex	964	HBF Textiles	12	•			•	•	•	•	•
Crosstweed	991	HBF Textiles	12	•	•	•	•	•	•	•	•
Cutout	SHBFCUT	HBF Textiles	12	•				•	•		
Dot Grid	975	HBF Textiles	12	•				•	•		
Dot Structure	SHBFDOT	HBF Textiles	12	•				•	•	•	•
Glint	SHBFGLT	HBF Textiles	12	•				•	•		
Grateful Grid	1015	HBF Textiles	12	•			•	•	•	•	•
Heartfelt	SHBFHTF	HBF Textiles	12	•	•	•	•	•	•	•	•
Lava Rock	993	HBF Textiles	12	•	•	•	•	•	•	•	•
Merci Boucle	SHBFMER	HBF Textiles	12	•	•	•	•	•	•	•	•
Moving Blanket	SHBFMOV	HBF Textiles	12					•			
Sable Island	SHBFSAB	HBF Textiles	12	•							
Sir Stripe A Lot	1004	HBF Textiles	12	•				•	•		

Seating

- Available upholstery option
- RR: railroaded, F/FR: Fire compliant model

Pattern Name	Code	Supplier	Grade	Rock - Cushions MDS 10269	Rock - Shell/Body MDS 10269	Rock Single Upholstery MDS 10269	Summit	Two Thirds Pour	Wedge Seat MDS 10269	Wedge Back MDS 10270	Wedge Single Upholstery MDS 10269
Sweater Weather	1030	HBF Textiles	12	•			•	•	•	•	•
Twist	SHBFTWS	HBF Textiles	12	•	•	•		•	•	•	•
Upstart	1042	HBF Textiles	12	•	•	•		•	•	•	•
Cherished Knit	954	HBF Textiles	13	•	•	•	•	•	•	•	•
Enriched Boucle	1021	HBF Textiles	13	•	•	•	•	•	•	•	•
Foundation	SHBFFND	HBF Textiles	13	•					•		
Moving Forward	1014	HBF Textiles	13	•			•	•			
Night Earth	1013	HBF Textiles	13	•	•	•	•	•	•	•	•
Pepper Blend	995	HBF Textiles	13	•	•	•	•	•	•	•	•
Quill	1011	HBF Textiles	13	•	•	•	•	•	•	•	•
Scribble XL	983	HBF Textiles	13	•				•	•		
Sister Solid	1003	HBF Textiles	13	•	•	•	•	•	•	•	•
Afghan	AFG	HBF Textiles	14	•	•	•		•	•	•	•
Smart	SHBFSMT	HBF Textiles	14	•				•	•		
Velvet Mix	977	HBF Textiles	14	•				•	•		
Hipster	SHBFHPT	HBF Textiles	15					•			
Landscape Blur	1024	HBF Textiles	15	•				•	•		
Poodle	1009	HBF Textiles	16	•	•	•	•	•	•	•	•
Sweater	SHBFSWE	HBF Textiles	16	•	•	•	•	•	•	•	•
Woven Memory	1019	HBF Textiles	16	•				•	•		
Crafted Cloud	1018	HBF Textiles	19	•				•	•		
Knitwork	SHBFKNI	HBF Textiles	21	•	•	•	•	•	•	•	•
Bunny	1012	HBF Textiles	23	•	•	•	•	•	•	•	•
Eccentric	966	HBF Textiles	23	•			•		•		
Eccentric	SHBFEC	HBF Textiles	23	•			•		•		
Wild West	717	HBF Textiles	L2	•				•	•		
Aviator	SHBFAVI	HBF Textiles	L3					•			
Free Way	SHBFFRE	HBF Textiles	L3					•			
Modern Patina	716	HBF Textiles	L3	•				•	•		
Persuede	718	HBF Textiles	L3	•				•	•		
Vivace II	709	HBF Textiles	L3					•			
Upper Crust	708	HBF Textiles	L5					•			
Voyage	713	HBF Textiles	L5					•			

UPHOLSTERY

LAMINATES

GRADE L1 – SOLID

Black P
 Flint LM16
 Loft LM11
 Designer White LDW1

GRADE L1 - WOODGRAIN

Bourbon Cherry H
 Field Elm LWFE
 Florence Walnut LFW1
 Kingswood Walnut LK11
 Natural Maple LWD
 NeoWalnut LNU1
 Shaker Cherry LW7C
 Pinnacle PINC

GRADE L2 – WOODGRAIN

Beigewood LWBE
 Lowell Ash LLA1
 Natural Recon LNR1
 Portico Teak LPT1
 Skyline Walnut LSW1
 Veranda Teak LVT1
 Fawn Cypress LFC1
 Phantom Ecrú LPE1

EDGE

Beigewood DE
 Black E4
 Bourbon Cherry H
 Designer White DW
 Fawn Cypress FC
 Field Elm FE
 Flint E9
 Florence Walnut FW
 Kingswood Walnut K1
 Loft EV
 Lowell Ash DL
 Natural Maple DD
 Natural Recon NR
 NeoWalnut NU
 Phantom Ecrú PE
 Portico Teak DP
 Shaker Cherry DF
 Skyline Walnut SW
 Veranda Teak VT
 Pinnacle PI

PAINT

GRADE P1

Textured Salt P8Z
 Textured Titanium P8V

GRADE P2

Solar Black P8X

NOTE: Refer to individual product pages for upcharges.

FSC Certified Wood at Allsteel
 See page 459 for more information.

Allsteel Seating Upholstery Selections by Model/Series.

Jetty:Mod

GRADE 1		
Apex	APX	•
Centurion	CU	•
Contourett	UR	•
Dapper	DAPR	•
Ensemble	ENSB	•
Hamilton <i>(De-emphasized)</i>	HAML	•
Inertia <i>(De-emphasized)</i>	NR	•
Optic <i>(De-emphasized)</i>	OP	•
GRADE 2		
Appoint Seating	PNS	•
Blume	BLME	•
Clyde	CLYD	•
Dotty <i>(De-emphasized)</i>	DOT	•
Meld	SMHMMLD	•
Rush	RUSH	•
Spin	SPNN	•
Whisper Vinyl	WP	•
GRADE 3		
Lateral	SCFSLAT	•
Moxie	SX	•
Parker	PRKR	•
Purl	PURL	•
Quill	QUL	•
GRADE 4		
Blink	1048	•
Caper	SMHMCAP	•
Look-See	1044	•
Manner	SMHMMAN	•
Merit	SMHMMER	•
Messenger	SMHMGRM	•
Metric	SMHMMET	•
Mode	SMHMMOD	•
Multiply	SMHMMLT	•
Murmur	SMHMMUR	•
Muse	SMHMMUS	•
Trundle	SMHMTRN	•
Walkabout	1046	•

Jetty:Mod

GRADE 5		
Checkmate	1043	
Main Line Flax	SCAMMLF	•
Riddle	SCFSRID	•
Stinson Sequence	SCFSSEQ	•
Zippy	1045	
GRADE 6		
Arris	ARR	•
Blazer	SCAMBLZ	•
Hemp	SCAMHMP	•
Poppy	1047	•
GRADE 7		
Silk	SCAMSLK	•
GRADE 8		
Apt	SMHMAPT	•
Brisa	RS	•
Zap	SCAMZAP	•
GRADE 9		
Ultraleather Pro	SUF554	•
Yoredale	SCAMYDL	•
GRADE L1		
Davenport	DAV	
Florence	FLOR	
Strasburg Leather	STB	

JETTY:MOD

⊕ Partnership Program — See page 10 for details.
 • Available upholstery option

- Allsteel fabrics and foam meet requirements for CTB117.
- Blank spaces indicate that a product has not yet been tested or that it failed.
- Contact Allsteel Customer Support for other flammability code approvals.

Jetty:Mod supports individual and group activities in cafes, atriums, and walkways while also influencing and directing circulation patterns. Its modern, modular, and can be modified to fit whatever the installation requires.

Jetty:Mod was designed to focus on work geometry and how to properly support you. Making sure to have proper sit depth and posture. There are two different versions or dimensions. The lounge version is 30" wide by 30" deep and you sit 18" off of the floor. This allows for more trust conversations to happen or to relax for the day. The work version is 24" wide by 24" deep and you sit 19.5" off of the floor. This will allow for a more upright position to do active work.



Lounge
18"H x 30"D x 30"W



Work
19.5"H x 24"D x 24"W

WORK GEOMETRY

It is important to determine whether the clearances between work mode/lounge mode and table are large enough to allow for an individual's legs to be positioned under the table and yet not too large as to result in awkward upper body positions when using the worksurface.

WORK POSTURE & STANDARD HEIGHT TABLE

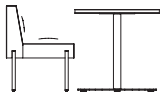

When specifying the work posture Jetty:Mod it is recommended to pair with standard height tables that provide 9"-10" of leg clearance.

Standard Table Height: 28"-29.75"

LOUNGE POSTURE & CONTINENTAL HEIGHT TABLE

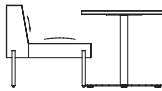

When specifying the lounge posture Jetty:Mod it is recommended to pair with continental height tables that provide 8.5"-10" of leg clearance.

Continental Table Height: 25"-27.75"

MODELS AND OPTIONS

Jetty:Mod is comprised of seating, arms, tables, screens, legs and connectors that allow you to create an array of configurations.

The seating includes Ottomans, Single Seats and Backs, Half-Backs, Serpentine Ottoman and Serpentine Seat and Back units.

Arms include Tailored Arms, Box Arms and Bolster Arm.

Tables are connected or an accessory to the overall configuration. These include Connecting Tables, both full and half, Serpentine Tables, End Caps, Shared Arm, Tablet Table and Coffee Table.

Screens provide privacy in any space. There are 4 different lengths of screens that can be attached to seating and tables.

Legs and connectors coincide with the work or lounge version.

APPLICATIONS

This sofa system supports applications for private offices, work islands, booths, individual workspaces and banquettes.

MATERIALS

All COMs/COLs must be approved for upholsterability. See pages 6-8 for COM ordering instructions.

OPTIONS — SEATING

Description:

Ottoman — Straight or Serpentine

Seat and Back — Straight, Serpentine, Half Back or Corner

FSC Certified Wood:

FSC FSC Certified Wood

Seat Upholstery:

See page 166 for upholstery selections.

Back Upholstery:

See page 166 for upholstery selections.

OPTIONS — ARMS

Description:

Tailored Arms - Left and Right

Box Arms - Left and Right

Bolster Arm

FSC Certified Wood:

FSC FSC Certified Wood

Upholstery:

See page 166 for upholstery selections.

OPTIONS — TABLES

Description:

Connecting Tables - Full, Half, Notched or Serpentine

Accessory Tables - End Caps, Shared Arm or Tablet Table

Tables - Coffee Table

FSC Certified Wood:

FSC FSC Certified Wood

Laminate Table Tops and Skirts:

See page 165 for laminate finishes and codes.

Painted Base:

See page 165 for paint finishes and codes.

OPTIONS — LEGS AND CONNECTORS

Description:

Legs and Connectors - Straight or Serpentine

Painted Legs and Connectors:

See page 165 for paint finishes and codes.

OPTIONS — SCREENS

Description:

24", 36", 30" and 45"

Screen Upholstery:

See page 166 for upholstery selections.

OPTIONS — ELECTRICAL

Description:

Electrical can be attached under seats and tables. Electrical includes Miki Undermount, hard wire and corded infeed wire options, and jumper kits that have 3 cord length options. See pages 198-199 for specifications and examples. See page 200 for electrical components.

A full gallery of typicals can be found on our website: <https://www.allsteeloffice.com/design-resources/idea-starters>. Each typical includes a complete BOM with current pricing, downloadable CAD files, and PDFs of each drawing.

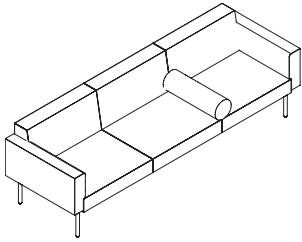

Reception

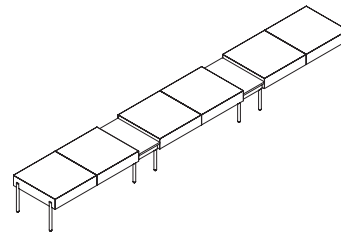

Meeting Overflow

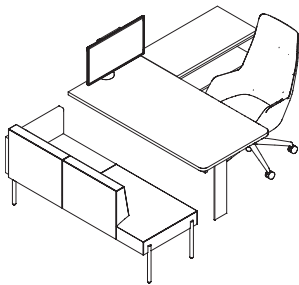

Micro Office

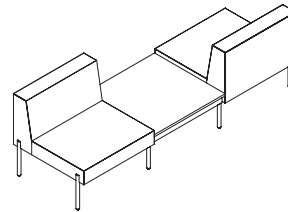

Yin Yang

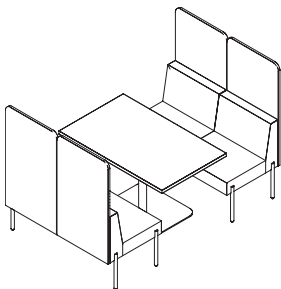

Booth

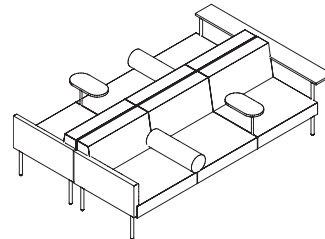

Back-to-Back

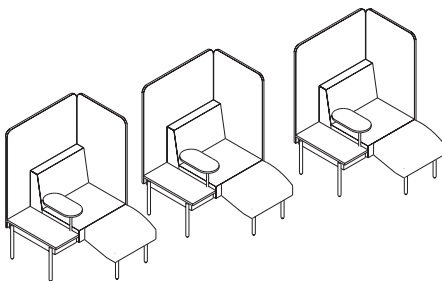

Focus Pod

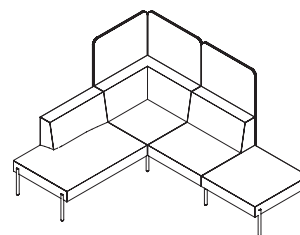

Small Gathering

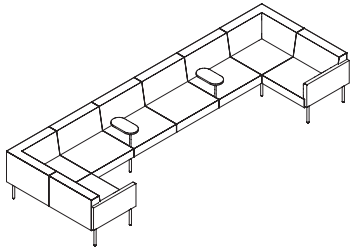

Usable U

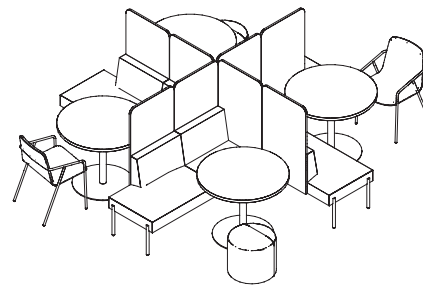

Meeting Pinwheel

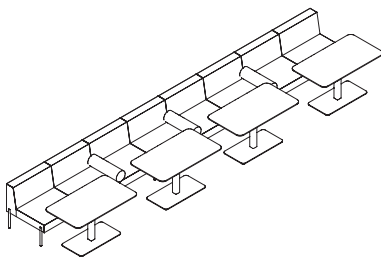

Banquette

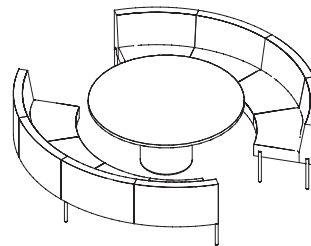

Firepit

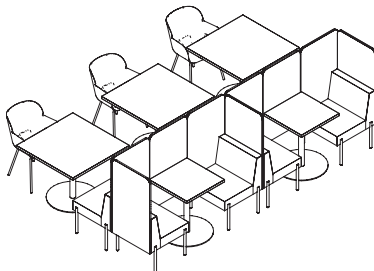

Booth Banquette

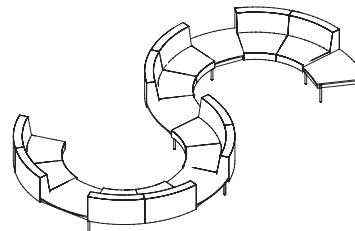

Organic

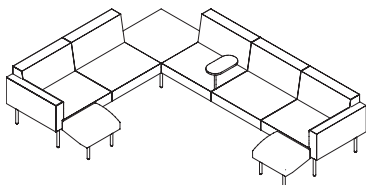

Usable L

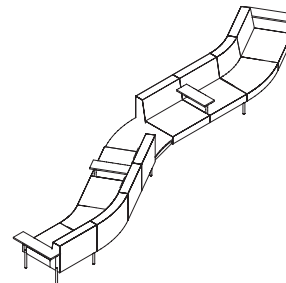

Serpentine

*Rule: Serpentine units need to have a leg at each connection point wherever there is the biggest radius. At the smallest radius, you will need a leg every 2 units. Where there isn't a leg, you can use a serpentine in-line connector.

General Guidelines When Working With Jetty:Mod

SEATING

Corner Units - BPLCS, BPLCM, BPLWCS, BPWCM

- Corner unit is used to make an L-application and should not be used to end a run
- Corner unit needs to be specified with 1-Corner connecting leg and 1-Post leg. (BPLCRPL and BPWCRPL)

Calf Rest - BPLCR

- Calf Rest can only be used with the lounge version of Jetty:Mod
- It is recommended to placed at the front of the sofa unit it is being attached to, and should be placed either to the right or the left of the unit. This will depend on what the application is.
- Calf Rest is attached with 2 brackets to the bottom of the sofa unit, and then comes with 2 post legs that will go at the end to support

Serpentine Units - BPLSWS, BPLSWM, BPLSNS, BPLSNM, BPLSO, BPWSWS, BPWSWM, BPWSNS, BPWSNM, BPWSO

- Serpentine units need to have a leg at each connection point wherever there is the biggest radius. At the smallest radius, you will need a leg every 2 units. Where there isn't a leg, you can use a serpentine in-line connector.

See specifying examples below

What to Specify:

- 4 Serpentine Wide at Back (BPLSWS)
- 4 End Leg with Metal Cover (BPLELC)
- 4 Serpentine In-Line Leg 30 (BPLSIL30)
- 2 Serpentine In-Line Connector 30 (BPSIC30)

What to Specify:

- 4 Serpentine Wide at Back (BPLSNS)
- 4 End Leg with Metal Cover (BPLELC)
- 4 Serpentine In-Line Leg 30 (BPLSIL30)
- 2 Serpentine In-Line Connector 30 (BPSIC30)

What to Specify:

- 2 Serpentine Wide at Back (BPLSWS)
- 2 Single Seat and Back (BPLSS)
- 4 End Leg with Metal Cover (BPLELC)
- 2 Serpentine In-Line Leg 30 (BPLSIL30)
- 2 Serpentine In-Line Leg 15 (BPLSIL15)
- 2 Serpentine In-Line Connector 15 (BPSIC15)

What to Specify:

- 2 Serpentine Wide at Back (BPLSNS)
 - 2 Single Seat and Back (BPLSS)
 - 4 End Leg with Metal Cover (BPLELC)
 - 2 Serpentine In-Line Leg 30 (BPLSIL30)
 - 2 Serpentine In-Line Leg 15 (BPLSIL15)
 - 2 Serpentine In-Line Connector 15 (BPSIC15)
- Note: This can also be done using the work version

What to Specify:

- 4 Serpentine Wide at Back (BPLSWS)
- 1 Serpentine Connecting Table (BPCTO30)
- 4 End Leg with Metal Cover (BPLELC)
- 6 Serpentine In-Line Leg 30 (BPLSIL30)
- 2 Serpentine In-Line Connector 30 (BPSIC30)

What to Specify:

- 4 Serpentine Wide at Back (BPLSNS)
- 1 Serpentine Connecting Table (BPCTO30)
- 4 End Leg with Metal Cover (BPLELC)
- 6 Serpentine In-Line Leg 30 (BPLSIL30)
- 2 Serpentine In-Line Connector 30 (BPSIC30)

What to Specify:

- 2 Serpentine Wide at Back (BPLSNS)
- 2 Single Seat and Back (BPLSS)
- 1 Serpentine Connecting Table (BPCTO30)
- 4 End Leg with Metal Cover (BPLELC)
- 4 Serpentine In-Line Leg 30 (BPLSIL30)
- 2 Serpentine In-Line Connector 15 (BPSIC15)

What to Specify:

- 2 Serpentine Wide at Back (BPLSWS)
- 2 Single Seat and Back (BPLSS)
- 1 Serpentine Connecting Table (BPCTO30)
- 4 End Leg with Metal Cover (BPLELC)
- 4 Serpentine In-Line Leg 30 (BPLSIL30)
- 2 Serpentine In-Line Connector 15 (BPSIC15)

HOW TO SPECIFY JETTY:MOD

EXAMPLE #1

- (3) BPLSS - Lounge Single Seat and Back
- (1) BPLB - Lounge Bolster Arm
- (1) BPLBL - Lounge Box Arm Left
- (1) BPLBR - Lounge Box Arm Right
- (4) BPLEL - Lounge End Leg for Attaching
- (4) BPLSIC - Lounge Straight In-Line Connector

EXAMPLE #2

- (1) BPLSS - Lounge Single Seat and Back
- (1) BPLCR - Lounge Calf Rest
- (1) BPBSCR30 - Lounge Screen 30"
- (1) BPBSCR45 - Lounge Screen 45"
- (1) BPCT15 - Half Connecting Table 15" x 30"
- (1) BPTT - Swivel Tablet
- (4) BPLELC - Lounge End Leg with Metal Cover
- (2) BSSICC - Short In-Line Connector

Note: One pod is specified, multiply by 3 for total

EXAMPLE #3

- (10) BPLSWS - Lounge Serpentine Wide at Back
- (5) BPLCTO30 - Lounge Serpentine Connecting Table
- (4) BPLELC - Lounge End Leg with Metal Cover
- (23) BPLSIL30 - Lounge Serpentine In-Line Leg 30
- (5) BPSIC30 - Serpentine In-line Connector 30

EXAMPLE #4

- (2) BPLSS - Lounge Single Seat and Back
- (1) BPCT30 - Connecting Table 30" x 30"
- (4) BPLELC - Lounge End Leg with Metal Cover
- (4) BPLSIL - Lounge Straight In-Line Leg

EXAMPLE #5

- (6) BPLSS - Lounge Single Seat and Back
- (2) BPLB - Lounge Bolster Arm
- (1) BPLTL - Lounge Tailored Arm Left
- (1) BPLTR - Lounge Tailored Arm Right
- (2) BPTT - Swivel Tablet
- (1) BPT60 - Lounge End Cap 60"
- (8) BPLEL - Lounge End Leg for Attaching
- (8) BPLSIC - Lounge Straight In-Line Connector

EXAMPLE #6

- (6) BPLSS - Lounge Single Seat and Back
- (1) BPLSWS - Lounge Serpentine Wide at Back
- (1) BPLSNS - Lounge Serpentine Wide at Back
- (1) BPLCTO30 - Lounge Serpentine Connecting Table
- (2) BPT30 - Lounge End Cap 30"
- (2) BPTS30 - Lounge Shared Arm
- (4) BPLEL - Lounge End Leg for Attaching
- (4) BPLSIC - Lounge Straight In-Line Connector
- (10) BPLSIL30 - Lounge Serpentine In-Line Leg 15
- (2) BPSIC15 - Serpentine In-line Connector 15

ARMS

Tailored Arms - BPLTL, BPLTR, BPWTL, BPWTR

- Tailored Arms can only be used at the end of the run, not in between units

Box Arms - BPLBL, BPLBR, BPWBL, BPWBR

- Box Arms can only be used at the end of the run, not in between units

Bolster Arms - BPLB, BPWB

- Bolster Arms can only be used in between units that have a seat and back. It is recommended to not be used with an ottoman

TABLES

Connecting Tables - BPCT30, BPCT24

- Connecting tables can go in between seating units and at the end of a run
- If a connecting table is in between 2 seat units, it will need 4 in-line legs (BPLSIL or BPWSIL) at each connection point between the units
- If a connecting table is placed at the end of a run, it will need 2 in-line legs (BPLSIL or BPWSIL) and then 2 end legs with a metal cover. You need a point of connection for the connecting tables

Half Connecting Tables - BPCT15, BPCT12

- Half connecting tables can go in between seating units and at the end of a run
- If a half connecting table is in between 2 seat units, it will need 2 in-line legs (BPLSIL or BPWSIL) at 2 of the connection points and the 2 short in-line (BSSICC) connectors at the other 2 connection points
- If a half connecting table is placed at the end of a run, it will need 2 short in-line connectors (BSSICC) and then 2 end legs with a metal cover. You need a point of connection for the half connecting tables

Serpentine Connecting Tables - BPCTO30, BPCTO24

- Serpentine connecting tables can go in between seating units and at the end of a run
- If a serpentine connecting table is in between 2 linear seat units, it will need 4 serpentine in-line legs (BPLSIL15 or BPWSIL15) at each of the connection points
- If a serpentine connecting table is in between 2 serpentine units, it will need 4 serpentine in-line legs (BPLSIL30 or BPWSIL30) at each of the connection points
- If a serpentine connecting table is in between 1 serpentine unit and 1 linear unit, the linear to serpentine will have a different leg compared to the serpentine to serpentine connection. You will need to specify 2 serpentine in-line legs (BPLSIL30 or BPWSIL30) and 2 serpentine in-line legs (BPLSIL15 or BPWSIL15)

Corner Connecting Tables - BPCCT30, BPCCT24

- Corner table is used to make an L-application and should not be used to end a run
- Corner unit needs to be specified with 1-Corner connecting leg and 1-Post leg. (BPLCRPL and BPWCRPL)

Notched Tables - BPNT30, BPNT15, BPNT24, BPNT12

- When pairing legs with notched tables, follow same guidelines that are used for connecting and half connecting tables
- It is recommended that you put a tablet arm within the notches. Items that we do not recommend are bolster arm, arms and the shared arm

End Caps - BPTE30, BPTE60, BPTE24, BPTE48

- End caps should be used at the end of a run, connecting into the end legs for attaching (BPTEL or BPWEL)
- The longer end caps are used to span across two units that are back-to-back

Shared Arms - BPTS30, BPTS24

- Shared arms are recommended to be used in between 2 seat and back units (serpentine or linear)

Swivel Tablet - BPTT

- Swivel tablet can go at the end of the run or in between units (serpentine or linear)

Coffee Table - BPCT2445

- Coffee table should be used on its own as a stand alone coffee table

LEGS, CONNECTORS AND METAL PIECES

You will need to specify two legs or connectors at each connection point. For example, if you have a two-seat sofa, you would need to specify two in-line connectors where the sofa units meet and then four end legs (two at one end and two at the other end of the sofa).

Straight In-Line Connectors - BPLSIC, BPWSIC

- Straight in-line connectors are used to connect 2 linear units together, both seating and tables
- Swivel tablet, bolster arm and shared arm can be inserted into the in-line connectors

End Legs for Attaching - BPTEL, BPWEL

- End legs for attaching are used at the end of a run
- Tailored arms, box arms and tablet arm can be inserted into the end legs at the end of a run

End Legs with Metal Cover - BPLELC, BPWELC

- End legs with the metal cover are used at the end of a run where nothing will be inserted or attached to them

Corner Post Legs - BPLCRPL, BPWCRPL

- Corner post legs are to be used with corner seating and tables
- When corner units are used, 2 corner post legs will need to be specified

Serpentine In-Line Connector - BPSIC15, BPSIC30

- BPSIC15 should be used when connecting a linear unit to a serpentine unit
- BPSIC30 should be used when connecting a serpentine unit to a serpentine unit

Serpentine In-Line Leg - BPLSIL15, BPLSIL30, BPWSIL15, BPWSIL30

- BPLSIL15 and BPWSIL15 should be used when connecting a linear unit to a serpentine unit
- BPLSIL30 and BPWSIL30 should be used when connecting a serpentine unit to a serpentine unit

4 Unit Beam Connector - BP4UC

- The 4 unit beam connector can be used to connect 4 linear units together without having to put a leg in between
- This cannot be used with serpentine units

Short In-Line Connector - BSSICC

- Short in-line connector should be used when connecting a single seat and back unit to a half connecting table, and should be placed in between those units





Coat Hanger - BPCH

- The coat hanger can be placed on the back of seat and back, half back and serpentine units

SCREENS

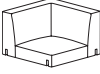
Screens - BPBSCR30, BPBSCR45, BPBSCR24, BPBSCR36

- The 30" and 45" screens should be paired with the lounge version, and the 24" and 36" should coincide with the work version
- Screens are attached to the bottom of the seat and tables
- Screens can go on the back and sides of seating units. Screens can be attached to the back of the tables, but cannot attach to the sides of them.
- They cannot be used in between units

Description	Model Number <i>Add options below</i>	Base Price	Upholstery	Upcharge							
				2	3	4	5	6	7	8	
 Single Seat and Back Single Upholstery	BPLSS	\$ 1976	Upholstery	\$ 60	\$ 120	\$ 180	\$ 260	\$ 341	\$ 420	\$ 500	
 Corner Single Upholstery	BPLCS	\$ 2398	Upholstery	\$ 87	\$ 172	\$ 258	\$ 371	\$ 486	\$ 600	\$ 714	
 Left Half Back Single Upholstery	BPLLS	\$ 2540	Upholstery	\$ 69	\$ 138	\$ 207	\$ 297	\$ 389	\$ 480	\$ 572	
 Right Half Back Single Upholstery	BPLRS	\$ 2540	Upholstery	\$ 69	\$ 138	\$ 207	\$ 297	\$ 389	\$ 480	\$ 572	
 Serpentine Wide at Back Single Upholstery	BPLSWS	\$ 2258	Upholstery	\$ 60	\$ 120	\$ 180	\$ 260	\$ 341	\$ 420	\$ 500	
 Serpentine Narrow at Back Single Upholstery	BPLSNS	\$ 2258	Upholstery	\$ 60	\$ 120	\$ 180	\$ 260	\$ 341	\$ 420	\$ 500	





JETTY:MOD

<p>How to specify — Select the Model Number from above.</p>	<p>1st Option: FSC Certified Wood: FSC Select for FSC Certified Wood</p>	<p>2nd Option: Select the Upholstery: See Allsteel Upholstery matrix on page 166.</p>
<p>B P L .</p>	<p>F S C .</p>	<p> </p>

Example: BPLSS.FSC.PURL05

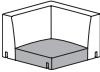
Model Number	Overall			Seat			Back						
	Ship Weight	Calves	COM Yardage*	Height	Width	Depth	Height	Width	Depth	Height	Width	Top Depth	Bottom Depth
BPLSS	41	14.5	3.4	18½"	30"	30"	7"	30"	21½"	18½"	30"	3.42"	7.69"
BPLCS	57	14.5	4.8	18½"	30"	30"	7"	21½"	21½"	18½"	30"	3.42"	7.69"
BPLLS	53	20	3.9	18½"	45"	30"	7"	45"	21½"	18½"	30"	3.42"	7.69"
BPLRS	53	20	3.9	18½"	45"	30"	7"	45"	21½"	18½"	30"	3.42"	7.69"
BPLSWS	42	15.2	3.4	18½"	Back: 35½" Front: 20"	30"	7"	Back: 35½" Front: 20"	21½"	18½"	35½"	3.42"	7.69"
BPLSNS	42	15.2	3.5	18½"	Back: 20" Front: 35½"	30"	7"	Back: 20" Front: 35½"	21½"	18½"	20"	3.42"	7.69"

*COM Yardage is listed for total yardage/feet required for a model, with applicable yardage/feet for individual components listed.

Description	Model Number <i>Add options below</i>	Base Price	Upholstery	Upcharge								
				2	3	4	5	6	7	8		
Jetty:Mod Lounge												
	Single Seat and Back	BPLSM	\$ 2116	Seat	\$ 28	\$ 55	\$ 82	\$ 119	\$ 155	\$ 192	\$ 229	
	Multi Upholstery			Back	\$ 33	\$ 66	\$ 99	\$ 141	\$ 185	\$ 228	\$ 272	
	Corner	BPLCM	\$ 2681	Seat	\$ 24	\$ 48	\$ 72	\$ 104	\$ 137	\$ 168	\$ 200	
	Multi Upholstery			Back	\$ 63	\$ 124	\$ 186	\$ 268	\$ 350	\$ 432	\$ 514	
	Left Half Back	BPLLM	\$ 2715	Seat	\$ 33	\$ 66	\$ 99	\$ 141	\$ 185	\$ 228	\$ 272	
	Multi Upholstery			Back	\$ 36	\$ 72	\$ 108	\$ 156	\$ 204	\$ 252	\$ 300	
	Right Half Back	BPLRM	\$ 2715	Seat	\$ 33	\$ 66	\$ 99	\$ 141	\$ 185	\$ 228	\$ 272	
	Multi Upholstery			Back	\$ 36	\$ 72	\$ 108	\$ 156	\$ 204	\$ 252	\$ 300	
	Serpentine Wide at Back	BPLSWM	\$ 2433	Seat	\$ 28	\$ 55	\$ 82	\$ 119	\$ 155	\$ 192	\$ 229	
	Multi Upholstery			Back	\$ 33	\$ 66	\$ 99	\$ 141	\$ 185	\$ 228	\$ 272	
	Serpentine Narrow at Back	BPLSNM	\$ 2433	Seat	\$ 30	\$ 58	\$ 88	\$ 127	\$ 165	\$ 204	\$ 244	
	Multi Upholstery			Back	\$ 31	\$ 63	\$ 93	\$ 135	\$ 175	\$ 216	\$ 258	









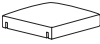

JETTY:MOD

<p>How to specify — Select the Model Number from above.</p> <p>B P L .</p>	<p>1st Option: FSC Certified Wood: FSC Select for FSC Certified Wood</p> <p>F S C .</p>	<p>2nd Option: Select the Seat Upholstery: See Allsteel Upholstery matrix on page 166.</p> <p> .</p>	<p>3rd Option: Select the Back Upholstery: See Allsteel Upholstery matrix on page 166.</p> <p> .</p>
--	---	---	---

Example: BPLSM.FSC.BLME03.BLME09

Model Number	Overall					Seat				Back				
	Ship Weight	Calves	Height	Width	Depth	COM Yardage	Height	Width	Depth	COM Yardage	Height	Width	Top Depth	Bottom Depth
BPLSM	41	14.5	18½"	30"	30"	1.1	7"	30"	21½"	1.7	18½"	30"	3.42"	7.69"
BPLCM	57	14.5	18½"	30"	30"	1.1	7"	21½"	21½"	3.0	18½"	30"	3.42"	7.69"
BPLLM	53	20	18½"	45"	30"	1.7	7"	45"	21½"	1.7	18½"	30"	3.42"	7.69"
BPLRM	53	20	18½"	45"	30"	1.9	7"	45"	21½"	1.7	18½"	30"	3.42"	7.69"
BPLSWM	42	15.2	18½"	Back: 35½" Front: 20"	30"	1.1	7"	Back: 35½" Front: 20"	21½"	1.7	18½"	35½"	3.42"	7.69"
BPLSNM	42	15.2	18½"	Back: 20" Front: 35½"	30"	1.4	7"	Back: 20" Front: 35½"	21½"	1.5	18½"	20"	3.42"	7.69"

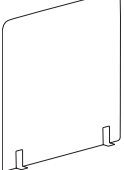
*COM Yardage is listed for total yardage/feet required for a model, with applicable yardage/feet for individual components listed.

Description	Model Number <i>Add options below</i>	Base Price	Upholstery	Upcharge								P2 Paint
				2	3	4	5	6	7	8		
 Ottoman	BPLO	\$ 1552	Upholstery	\$ 40	\$ 79	\$ 118	\$ 172	\$ 224	\$ 276	\$ 329	N/A	
 Serpentine Ottoman	BPLSO	\$ 1763	Upholstery	\$ 40	\$ 79	\$ 118	\$ 172	\$ 224	\$ 276	\$ 329	N/A	
 Tailored Arm Left	BPLTL	\$ 847	Upholstery	\$ 24	\$ 48	\$ 72	\$ 104	\$ 137	\$ 168	\$ 200	N/A	
 Tailored Arm Right	BPLTR	\$ 847	Upholstery	\$ 24	\$ 48	\$ 72	\$ 104	\$ 137	\$ 168	\$ 200	N/A	
 Box Arm Left	BPLBL	\$ 988	Upholstery	\$ 24	\$ 48	\$ 72	\$ 104	\$ 137	\$ 168	\$ 200	N/A	
 Box Arm Right	BPLBR	\$ 988	Upholstery	\$ 24	\$ 48	\$ 72	\$ 104	\$ 137	\$ 168	\$ 200	N/A	
 Bolster Arm	BPLB	\$ 777	Upholstery	\$ 18	\$ 34	\$ 52	\$ 75	\$ 98	\$ 120	\$ 143	N/A	
 Screen 30"	BPBSCR30	\$ 1235	Upholstery	\$ 57	\$ 114	\$ 171	\$ 246	\$ 321	\$ 396	\$ 471	N/A	
 Screen 45"	BPBSCR45	\$ 1375	Upholstery	\$ 57	\$ 114	\$ 171	\$ 246	\$ 321	\$ 396	\$ 471	N/A	
 Calf Rest	BPLCR	\$ 1130	Upholstery	\$ 19	\$ 39	\$ 57	\$ 82	\$ 107	\$ 132	\$ 157	\$ 88	





JETTY:MOD

<p>How to specify — Select the Model Number from above.</p>	<p><i>1st Option:</i> FSC Certified Wood: FSC Select for FSC Certified Wood</p>	<p><i>2nd Option:</i> Select the Upholstery: See Allsteel Upholstery matrix on page 166.</p>	<p><i>3rd Option:</i> Select the Paint Finish (if applicable): See Paint Finishes on page 165.</p>
<p>B P .</p>	<p>F S C .</p>	<p> .</p>	<p> </p>

Example: BPLBR.FSC.PURL03

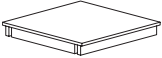
Model Number	Overall					
	Ship Weight	Calves	COM Yardage*	Height	Width	Depth
BPLO	32	4.9	2.2	7"	30"	30"
BPLSO	32	6	2.2	7"	Back: 35½" Front: 20"	30"
BPLTL	12	2.9	1.3	13¾"	30"	2¼"
BPLTR	12	2.9	1.3	13¾"	30"	2¼"
BPLBL	17	2.9	1.5	13¾"	30"	4¼"
BPLBR	17	2.9	1.5	13¾"	30"	4¼"
BPLB	6	1.5	1	7"	22½"	
BPBSCR30	20	5	3.3	41"	30"	1"
BPBSCR45	28	7.4	3.3	41"	45"	1"
BPLCR	12	1.6	1.2	14⅞"	20"	15"

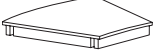
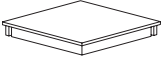
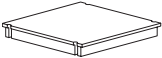
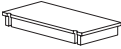
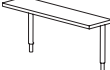
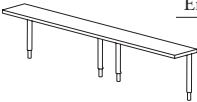
*COM Yardage is listed for total yardage/feet required for a model, with applicable yardage/feet for individual components listed.

Description	Model Number <i>Add options below</i>	Base Price	Upcharge List Price — Add to Base Price		
			L2	P2 Paint	
 Connecting Table 30" x 30"	BPCT30	\$ 1341	\$ 0		N/A
 Half Connecting Table 15" x 30"	BPCT15	\$ 1059	\$ 0		N/A
 Serpentine Connecting Table	BPCTO30	\$ 1481	\$ 0		N/A
 Corner Connecting Table	BPCCT30	\$ 1341	\$ 0		N/A
 Notched Connecting Table 30" x 30"	BPNT30	\$ 1411	\$ 0		N/A
 Notched Half Connecting Table 15" x 30"	BPNT15	\$ 1130	\$ 0		N/A
 End Cap 30"	BPTE30	\$ 811	\$ 32		\$ 64
 End Cap 60"	BPTE60	\$ 953	\$ 38		\$ 75
 Shared Arm	BPTS30	\$ 811	\$ 32		\$ 64







JETTY:MOD

<p>How to specify — Select the Model Number from above.</p>	<p>1st Option: FSC Certified Wood: FSC Select for FSC Certified Wood</p>	<p>2nd Option: Select the Top Laminate: See page 165 for options.</p>	<p>3rd Option: Select the Top Edge Band: See page 165 for options.</p>	<p>4th Option: Select the Skirt Laminate (if applicable): See page 165 for options. The skirt will come with a matching edgeband.</p>	<p>5th Option: Select the Paint Finish (if applicable): See Paint Finishes on page 165.</p>
B P .	F S C

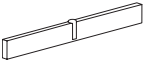
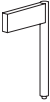
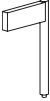
Examples: BPCT30.FSC.LDW1.DW.LDW1 BPTE30.FSC.LDW1.DW.P8X

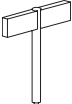
Model Number	Overall					
	Ship Weight	Calves	COM Yardage*	Height	Width	Depth
BPCT30	49	4.1	N/A	3.481"	30"	30"
BPCT15	32	2.2	N/A	3.481"	15"	30"
BPCTO30	48	5	N/A	3.481"	Back: 35½" Front: 20"	30"
BPCCT30	49	4.1	N/A	3.481"	30"	30"
BPNT30	49	4.1	N/A	3.481"	30"	30"
BPNT15	32	2.2	N/A	3.481"	15"	30"
BPTE30	20	0.8	N/A	12.981"	8"	30½"
BPTE60	26	1.5	N/A	12.981"	8"	60¼"
BPTS30	18	0.6	N/A	12.981"	8"	27.62"

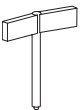
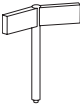
*COM Yardage is listed for total yardage/feet required for a model, with applicable yardage/feet for individual components listed.

Description	Model Number <i>Add options below</i>	Base Price	P2 Paint Upcharge
Jetty:Mod Lounge			
 Straight In-Line Connector *Only comes in Solar Black	BPLSIC	\$ 106	N/A
 End Leg for Attaching	BPLEL	\$ 120	\$ 10
 End Leg with Metal Cover *Metal Cover matches chosen paint color	BPLELC	\$ 127	\$ 10
 Corner Post Leg	BPLCRPL	\$ 135	\$ 11
 Straight In-Line Leg	BPLSIL	\$ 127	\$ 10
 Connecting Post Leg	BPLCPL	\$ 135	\$ 11
 Single Post Leg	BPLSPL	\$ 106	\$ 9
 Serpentine In-Line Leg 15	BPLSIL15	\$ 148	\$ 12
 Serpentine In-Line Leg 30	BPLSIL30	\$ 148	\$ 12
 4 Unit Beam Connector *Only comes in Solar Black (P8X)	BP4UC	\$ 676	N/A

JETTY:MOD





<p>How to specify — Select the Model Number from above.</p>	<p>1st Option: Select the Paint Finish (if applicable): See Paint Finishes on page 165.</p>
<p>B P L .</p>	<p> </p>

Example: BPLCPL.P8X

Model Number	Overall						
	Ship Weight	Calves	COM Yardage*	Height	Width	Depth	Leg Diameter
BPLSIC	4	1.7	N/A	2½"	25½"	1"	1½"
BPLEL	3	1.2	N/A	12½"	8.062"	1"	1½"
BPLELC	3	1.2	N/A	12½"	8.062"	1"	1½"
BPLCRPL	3	0.8	N/A	9½"	8¼"	8¼"	1½"
BPLSIL	3	1.2	N/A	12½"	30"	1"	1½"
BPLCPL	3	0.5	N/A	3.481"	12"	30"	1½"
BPLSPL	2	0.5	N/A	9½"	3"	3"	1½"
BPLSIL15	3	0.4	N/A	12½"	12"	1"	1½"
BPLSIL30	3	0.4	N/A	12½"	12"	1"	1½"
BP4UC	23	0.2	N/A	2½"	104"	1.13"	

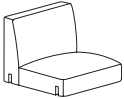
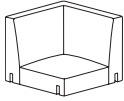
*COM Yardage is listed for total yardage/feet required for a model, with applicable yardage/feet for individual components listed.

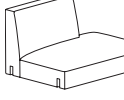
JETTY:MOD

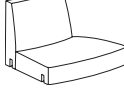
Description	Model Number <i>Add options below</i>	Base Price	Upholstery	Upcharge							
				2	3	4	5	6	7	8	
 Single Seat and Back Single Upholstery	BPWSS	\$ 1763	Upholstery	\$ 57	\$ 114	\$ 171	\$ 246	\$ 321	\$ 396	\$ 471	
 Corner Single Upholstery	BPWCS	\$ 2258	Upholstery	\$ 79	\$ 159	\$ 237	\$ 342	\$ 447	\$ 552	\$ 657	
 Left Half Back Single Upholstery	BPWLS	\$ 2258	Upholstery	\$ 66	\$ 130	\$ 196	\$ 283	\$ 369	\$ 456	\$ 543	
 Right Half Back Single Upholstery	BPWRS	\$ 2258	Upholstery	\$ 66	\$ 130	\$ 196	\$ 283	\$ 369	\$ 456	\$ 543	
 Serpentine Wide at Back Single Upholstery	BPWSWS	\$ 2045	Upholstery	\$ 58	\$ 117	\$ 175	\$ 253	\$ 331	\$ 408	\$ 486	
 Serpentine Narrow at Back Single Upholstery	BPWSNS	\$ 2045	Upholstery	\$ 58	\$ 117	\$ 175	\$ 253	\$ 331	\$ 408	\$ 486	



JETTY:MOD

<p>How to specify — Select the Model Number from above.</p>	<p>1st Option: FSC Certified Wood: FSC Select for FSC Certified Wood</p>	<p>2nd Option: Select the Upholstery: See Allsteel Upholstery matrix on page 166.</p>
<p>B P W .</p>	<p>F S C .</p>	<p> </p>

Example: BPWSS.FSC.BLME14

Model Number				Overall			Seat			Back			
	Ship Weight	Calves	COM Yardage*	Height	Width	Depth	Height	Width	Depth	Height	Width	Top Depth	Bottom Depth
BPWSS	30	12.3	3.2	18"	24"	24"	7"	24"	17½"	18½"	24"	1.418"	5.689"
BPWCS	46	12.3	2.9	18"	24"	24"	7"	17½"	17½"	18½"	24"	1.418"	5.689"
BPWLS	42	15.2	3.7	18"	36"	24"	7"	36"	17½"	18½"	23¾"	1.418"	5.689"
BPWRS	42	15.2	3.7	18"	36"	24"	7"	36"	17½"	18½"	23¾"	1.418"	5.689"
BPWSWS	31	15.2	3.3	18"	Back: 32¾" Front: 19.7"	25½"	7"	Back: 32¾" Front: 19.7"	17½"	18½"	32¾"	1.418"	5.689"
BPWSNS	31	15.2	3.3	18"	Back: 22¾" Front: 32¾"	25½"	7"	Back: 22¾" Front: 32¾"	17½"	18½"	22¾"	1.418"	5.689"

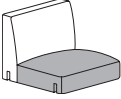
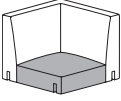
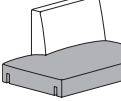
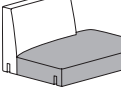
*COM Yardage is listed for total yardage/feet required for a model, with applicable yardage/feet for individual components listed.

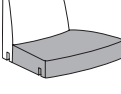
Description	Model Number <i>Add options below</i>	Base Price	Upholstery	Upcharge							
				2	3	4	5	6	7	8	
 Single Seat and Back Multi Upholstery	BPWSM	\$ 1905	Seat	\$ 27	\$ 52	\$ 78	\$ 112	\$ 147	\$ 180	\$ 214	
			Back	\$ 31	\$ 63	\$ 93	\$ 135	\$ 175	\$ 216	\$ 258	
 Corner Multi Upholstery	BPWCM	\$ 2540	Seat	\$ 22	\$ 45	\$ 67	\$ 98	\$ 127	\$ 156	\$ 186	
			Back	\$ 58	\$ 117	\$ 175	\$ 253	\$ 331	\$ 408	\$ 486	
 Left Half Back Multi Upholstery	BPWLM	\$ 2433	Seat	\$ 33	\$ 66	\$ 99	\$ 141	\$ 185	\$ 228	\$ 272	
			Back	\$ 33	\$ 66	\$ 99	\$ 141	\$ 185	\$ 228	\$ 272	
 Right Half Back Multi Upholstery	BPWRM	\$ 2433	Seat	\$ 33	\$ 66	\$ 99	\$ 141	\$ 185	\$ 228	\$ 272	
			Back	\$ 33	\$ 66	\$ 99	\$ 141	\$ 185	\$ 228	\$ 272	
 Serpentine Wide at Back Multi Upholstery	BPWSWM	\$ 2222	Seat	\$ 27	\$ 52	\$ 78	\$ 112	\$ 147	\$ 180	\$ 214	
			Back	\$ 33	\$ 66	\$ 99	\$ 141	\$ 185	\$ 228	\$ 272	
 Serpentine Narrow at Back Multi Upholstery	BPWSNM	\$ 2222	Seat	\$ 28	\$ 55	\$ 82	\$ 119	\$ 155	\$ 192	\$ 229	
			Back	\$ 31	\$ 63	\$ 93	\$ 135	\$ 175	\$ 216	\$ 258	









JETTY:MOD

<p>How to specify — Select the Model Number from above.</p> <p>B P W .</p>	<p>1st Option: FSC Certified Wood: FSC Select for FSC Certified Wood</p> <p>F S C .</p>	<p>2nd Option: Select the Seat Upholstery: See Allsteel Upholstery matrix on page 166.</p> <p> .</p>	<p>3rd Option: Select the Back Upholstery: See Allsteel Upholstery matrix on page 166.</p> <p> .</p>
--	---	---	---

Example: BPWSM.FSC.WP20.WP40

Model Number	Overall					Seat					Back			
	Ship Weight	Calves	Height	Width	Depth	COM Yardage	Height	Width	Depth	COM Yardage	Height	Width	Top Depth	Bottom Depth
BPWSM	30	12.3	18½"	24"	24"	1.1	7"	24"	17½"	1.4	18½"	24"	1.418"	5.689"
BPWCM	46	12.3	18½"	24"	24"	1.1	7"	17½"	17½"	2.2	18½"	24"	1.418"	5.689"
BPWLM	42	15.2	18½"	36"	24"	1.7	7"	36"	17½"	1.4	18½"	23¾"	1.418"	5.689"
BPWRM	42	15.2	18½"	36"	24"	1.7	7"	36"	17½"	1.4	18½"	23¾"	1.418"	5.689"
BPWSWM	31	15.2	18½"	Back: 32¾" Front: 19.7"	25½"	1.1	7"	Back: 32¾" Front: 19.7"	17½"	1.4	18½"	32¾"	1.418"	5.689"
BPWSNM	31	15.2	18½"	Back: 22¾" Front: 32¾"	25½"	1.1	7"	Back: 22¾" Front: 32¾"	17½"	1.4	18½"	22¾"	1.418"	5.689"

*COM Yardage is listed for total yardage/feet required for a model, with applicable yardage/feet for individual components listed.

Description	Model Number <i>Add options below</i>	Base Price	Upholstery	Upcharge								
				2	3	4	5	6	7	8		
Jetty:Mod Work												
 Ottoman	BPWO	\$ 1411	Upholstery	\$ 34	\$ 69	\$ 103	\$ 149	\$ 195	\$ 240	\$ 286		
 Serpentine Ottoman	BPWSO	\$ 1552	Upholstery	\$ 36	\$ 72	\$ 108	\$ 156	\$ 204	\$ 252	\$ 300		
 Tailored Arm Left	BPWTL	\$ 777	Upholstery	\$ 24	\$ 48	\$ 72	\$ 104	\$ 137	\$ 168	\$ 200		
 Tailored Arm Right	BPWTR	\$ 777	Upholstery	\$ 24	\$ 48	\$ 72	\$ 104	\$ 137	\$ 168	\$ 200		
 Box Arm Left	BPWBL	\$ 917	Upholstery	\$ 24	\$ 48	\$ 72	\$ 104	\$ 137	\$ 168	\$ 200		
 Box Arm Right	BPWBR	\$ 917	Upholstery	\$ 24	\$ 48	\$ 72	\$ 104	\$ 137	\$ 168	\$ 200		
 Bolster Arm	BPWB	\$ 706	Upholstery	\$ 18	\$ 34	\$ 52	\$ 75	\$ 98	\$ 120	\$ 143		
 Screen 24"	BPBSCR24	\$ 1165	Upholstery	\$ 57	\$ 114	\$ 171	\$ 246	\$ 321	\$ 396	\$ 471		
 Screen 36"	BPBSCR36	\$ 1304	Upholstery	\$ 57	\$ 114	\$ 171	\$ 246	\$ 321	\$ 396	\$ 471		







JETTY:MOD

<p>How to specify — Select the Model Number from above.</p>	<p>1st Option: FSC Certified Wood: FSC Select for FSC Certified Wood</p>	<p>2nd Option: Select the Upholstery: See Allsteel Upholstery matrix on page 166.</p>
<p>B P .</p>	<p>F S C .</p>	<p> .</p>

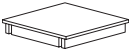
Example: BPWBR.FSC.WP20

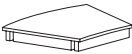
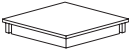
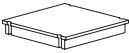
Model Number	Overall					
	Ship Weight	Calves	COM Yardage*	Height	Width	Depth
BPWO	21	4.9	1.9	7"	24"	24"
BPWSO	21	6	2	7"	Back: 32½" Front: 19.7"	24"
BPWTL	11	2.9	1.3	13¾"	24"	2¼"
BPWTR	11	2.9	1.3	13¾"	24"	2¼"
BPWBL	14	2.9	1.4	13¾"	24"	4¼"
BPWBR	14	2.9	1.4	13¾"	24"	4¼"
BPWB	6	1.5	1	7"	18½"	
BPBSCR24	17	5	1.8	41"	24"	1"
BPBSCR36	23	6	3.3	41"	36"	1"

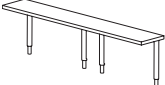
*COM Yardage is listed for total yardage/feet required for a model, with applicable yardage/feet for individual components listed.

Description	Model Number <i>Add options below</i>	Base Price	Upcharge List Price — Add to Base Price		
			L2		P2 Paint
 Connecting Table 24" x 24"	BPCT24	\$ 1199	\$ 0		N/A
 Half Connecting Table 12" x 24"	BPCT12	\$ 917	\$ 0		N/A
 Serpentine Connecting Table	BPCTO24	\$ 1341	\$ 0		N/A
 Corner Connecting Table	BPCCT24	\$ 1199	\$ 0		N/A
 Notched Connecting Table 24" x 24"	BPNT24	\$ 1270	\$ 0		N/A
 Notched Half Connecting Table 12" x 24"	BPNT12	\$ 988	\$ 0		N/A
 End Cap 24"	BPTE24	\$ 741	\$ 29		\$ 58
 End Cap 48"	BPTE48	\$ 882	\$ 34		\$ 69
 Shared Arm	BPTS24	\$ 741	\$ 29		\$ 58





JETTY:MOD

<p>How to specify — Select the Model Number from above.</p>	<p>1st Option: FSC Certified Wood: FSC Select for FSC Certified Wood</p>	<p>2nd Option: Select the Top Laminate: See page 165 for options.</p>	<p>3rd Option: Select the Top Edge Band: See page 165 for options.</p>	<p>4th Option: Select the Skirt Laminate (if applicable): See page 165 for options. The skirt will come with a matching edgeband.</p>	<p>5th Option: Select the Paint Finish (if applicable): See Paint Finishes on page 165.</p>
B P .	F S C

Examples: BPCT24.FSC.LDW1.DW.LDW1 BPTE48.FSC.LDW1.DW.P8X

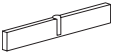
Model Number	Overall					
	Ship Weight	Calves	COM Yardage*	Height	Width	Depth
BPCT24	37	2.7	N/A	3.481"	24"	24"
BPCT12	25	1.5	N/A	3.481"	12"	24"
BPCTO24	41	3.8	N/A	3.481"	Back: 32.423" Front: 20"	24"
BPCCT24	37	2.7	N/A	3.481"	24"	24"
BPNT24	37	2.7	N/A	3.481"	24"	24"
BPNT12	25	1.5	N/A	3.481"	12"	24"
BPTE24	19	0.7	N/A	12.981"	8"	24½"
BPTE48	23½	1.2	N/A	12.981"	8"	48½"
BPTS24	16	0.4	N/A	12.981"	6"	21.62"

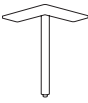
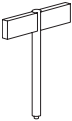
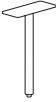
*COM Yardage is listed for total yardage/feet required for a model, with applicable yardage/feet for individual components listed.

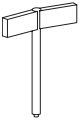
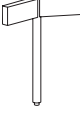
Description	Model Number <i>Add options below</i>	Base Price	P2 Paint Upcharge
Jetty:Mod Work			
 Straight In-Line Connector <i>*Only comes in Solar Black</i>	BPWSIC	\$ 84	N/A
 End Leg for Attaching	BPWEL	\$ 99	\$ 8
 End Leg with Metal Cover <i>*Metal Cover matches chosen paint color</i>	BPWELC	\$ 106	\$ 9
 Corner Post Leg	BPWCRPL	\$ 113	\$ 9
 Straight In-Line Leg	BPWSIL	\$ 106	\$ 9
 Connecting Post Leg	BPWCPL	\$ 113	\$ 9
 Single Post Leg	BPWSPL	\$ 84	\$ 7
 Serpentine In-Line Leg 15 15 degree turn	BPWSIL15	\$ 127	\$ 10
 Serpentine In-Line Leg 30 30 degree turn	BPWSIL30	\$ 127	\$ 10





JETTY:MOD

<p>How to specify — Select the Model Number from above.</p>	<p>1st Option: Select the Paint Finish (if applicable): See Paint Finishes on page 165.</p>
<p>B P L .</p>	<p> </p>

Example: BPWSIL.P8V

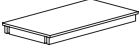
Model Number	Overall						
	Ship Weight	Calves	COM Yardage*	Height	Width	Depth	Leg Diameter
BPWSIC	3	1.7	N/A	2½"	19½"	1"	
BPWEL	3	1.2	N/A	13.953"	6.346"	1"	1½"
BPWELC	3	1.2	N/A	14"	6.346"	1"	1½"
BPWCRPL	3	0.8	N/A	11½"	8½"	8½"	1½"
BPWSIL	3	1.2	N/A	13½"	12"	1"	1½"
BPWCPL	3	0.5	N/A	11½"	7½"	3"	1½"
BPWSPL	3	0.5	N/A	11½"	3"	3"	1½"
BPWSIL15	3	0.4	N/A	13½"	12"	1"	1½"
BPWSIL30	3	0.4	N/A	13½"	12"	1"	1½"

*COM Yardage is listed for total yardage/feet required for a model, with applicable yardage/feet for individual components listed.

Description	Model Number <i>Add options below</i>	Base Price	Upcharge List Price — Add to Base Price	
			L2	P2 Paint
Jetty:Mod Lounge and Work (Used Across Both)				
 Swivel Tablet	BPTT	\$ 600	\$ 23	\$ 47
 Coffee Table 24" x 45"	BPCT2445	\$ 1693	\$ 0	N/A
 Coat Hanger	BPCH	\$ 353	N/A	\$ 28
 Short In-Line Connector *Only comes in Solar Black (P8X)	BSSICC	\$ 78	N/A	N/A
 Serpentine In-Line Connector 15 *Only comes in Solar Black (P8X) *15 degree turn	BPSIC15	\$ 113	N/A	N/A
 Serpentine In-Line Connector 30 *Only comes in Solar Black (P8X) *30 degree turn	BPSIC30	\$ 113	N/A	N/A

JETTY:MOD

<p>How to specify — Select the Model Number from above.</p> <p>B P .</p>	<p>1st Option: FSC Certified Wood: FSC Select for FSC Certified Wood</p> <p>F S C .</p>	<p>2nd Option: Select the Top Laminate: See page 165 for options.</p> <p> .</p>	<p>3rd Option: Select the Top Edge Band: See page 165 for options.</p> <p> .</p>	<p>4th Option: Select the Skirt Laminate (if applicable): See page 165 for options. The skirt will come with a matching edgeband.</p> <p> .</p>	<p>5th Option: Select the Paint Finish (if applicable): See Paint Finishes on page 165.</p> <p> .</p>
--	---	---	--	---	---

Example: BPCH.P8Z

Model Number	Overall					
	Ship Weight	Calves	COM Yardage*	Height	Width	Depth
BPTT	14	0.5	N/A	15.93"	16"	8"
BPCT2445	58	5.2	N/A	3.481"	45"	24"
BPCH	4	0.6	N/A	36.688"	4.53"	1½"
BSSICC	2	0.2	N/A	2½"	12"	1"
BPSIC15	3	0.2	N/A	2½"	12"	1"
BPSIC30	3	0.2	N/A	2½"	12"	1"

*COM Yardage is listed for total yardage/feet required for a model, with applicable yardage/feet for individual components listed.

Jetty:Mod electrical will be attached to the underside of the sofa. Electrical includes the Triplex system that has jumper kits, corded infeed, hardwire infeed and H-Connectors. Jumper kits, corded infeed and hardwire infeed are available at various lengths to support an array of configurations. Miki undermount units plugged into the Triplex system and placed at the front of the sofa. The Miki undermount power module has 1 simplex and 2 USB outlets.

It's the customer's responsibility to ensure that installation and use of the electrical system, the number of receptacles used on a given circuit, and connections to the building power supply meets all local and national electrical codes.

GUIDELINES WHEN WORKING WITH ELECTRICAL FOR JETTY:MOD

Miki Undermount - APWRMOD1UWM *(De-emphasized)*

- The Miki undermount consists of 1 simplex and 2 USB outlets
- Miki undermount power modules can be placed at the front of seat and table units. It cannot be placed where there is a support leg.
- 72" corded Miki undermount power modules can be specified on their own if the Jetty:Mod layout is placed along a wall with building power close enough to reach or within proximity of floor outlets.
- Miki can also be paired with the Triplex system to route a series of electrical components for larger Jetty:Mod configurations and/or if a hardwired in-feed is required/ desired.

Triplex Circuit 1 Jumper Kit - ATPKIT48, ATPKIT60, ATPKIT72

- Triplex Jumper Kits include 4-Trac Triplex Raceway available in lengths of 48", 60" and 72", conduit clamps and Triplex receptacle mounting bracket
- It is recommended to position the jumpers in the middle of the seat or table units that the electrical is going under

Triplex Circuit 2 Jumper Kit - ATPKIT482, ATPKIT602, ATPKIT722

- Triplex Jumper Kits include 4-Trac Triplex Raceway available in lengths of 48", 60" and 72", conduit clamps and Triplex receptacle mounting bracket
- It is recommended to position the jumpers in the middle of the seat or table units that the electrical is going under

Triplex Corded Infeed - ATPCIF48, ATPCIF72

- Triplex Corded Infeed includes a straight corded infeed with a straight 15 amp plug that is available in 48" and 72". Also available is an H-Connector with a mounting bracket.

Triplex Hardwire Infeed - ATPHWIF72

- Triplex Hardwire Infeed includes a straight hardwire infeed that is available in 72" and an H-Connector

Triplex H-Connector - ATPSPLIT

- H-Connectors are used to connector jumpers that will go in different directions whether that's a 90 degree turn or serpentine configurations

ELECTRICAL EXAMPLE 1 — L-SHAPE

- ATPCIF48 – 48” Triplex Corded Infeed (1)
- ATPKIT48 – 48” Triplex Circuit 1 Jumper Kit (2)
- APWRMOD1UWM – Miki Undermount (2)
(De-emphasized)

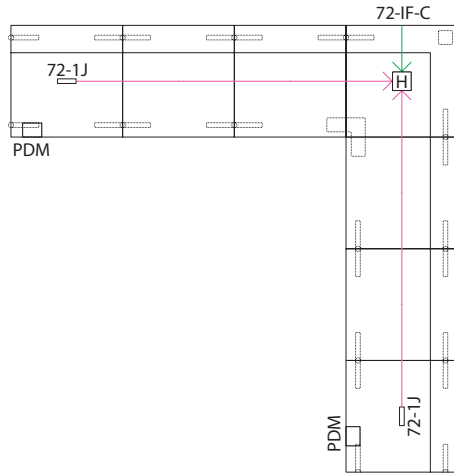

ELECTRICAL EXAMPLE 2 — U-SHAPE

- ATPCIF72 – 72” Triplex Corded Infeed (1)
- ATPKIT72 – 72” Triplex Circuit 1 Jumper Kit (2)
- APWRMOD1UWM – Miki Undermount (3)
(De-emphasized)

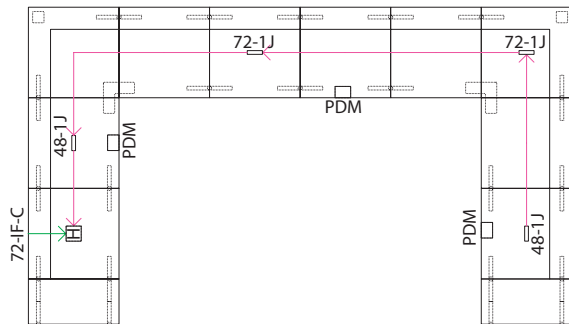

ELECTRICAL EXAMPLE 3 — LINEAR



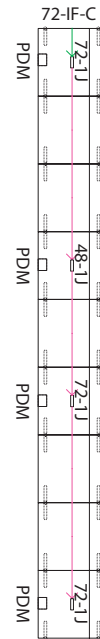

- ATPCIF48 – 48” Triplex Corded Infeed (1)
- ATPKIT60 – 60” Triplex Circuit 1 Jumper Kit (1)
- ATPKIT72 – 72” Triplex Circuit 1 Jumper Kit (1)
- APWRMOD1UWM – Miki Undermount (3)
(De-emphasized)

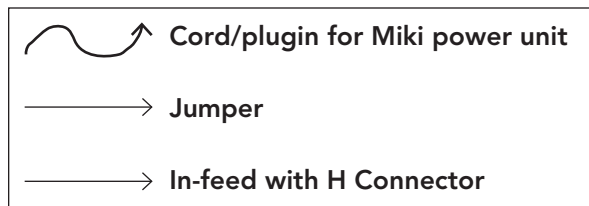
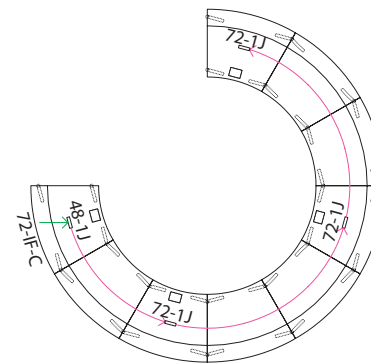

ELECTRICAL EXAMPLE 4 — SERPENTINE

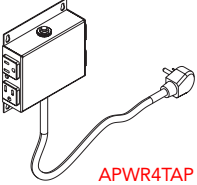
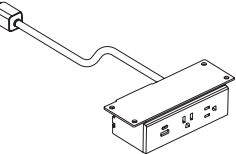
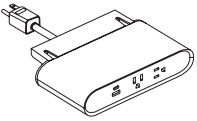
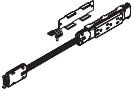
- ATPCIF72 – 72” Triplex Corded Infeed (1)
- ATPKIT72 – 72” Triplex Circuit 1 Jumper Kit (2)
- APWRMOD1UWM – Miki Undermount (3)
(De-emphasized)

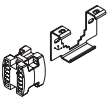

Description	Model Number <i>Add options below</i>	Base Price
Jetty:Mod Electrical		
 <p>APWR4TAP</p>	<p>Power/Data Module — Under Worksurface, Quad Tap 7"W x 12"D x 3"H APWR4TAP</p> <ul style="list-style-type: none"> • 4 receptacles • 10' Straight cord only, no specification needed. • Available in Black only, no specification needed. • <i>Example: APWR4TAP</i> 	<p>\$ 456</p>
 <p>AUPWRMOD.AC.S</p>	<p>Power Module — Under Worksurface, Rectangular 7½"W x 9¼"D x 5½"H AUPWRMOD</p> <ul style="list-style-type: none"> • 2 receptacles, 1 USB-A, & 1 USB-C (AC) • Power cord choices include a 10' Straight (S), 5' Interlink (I), 10' Hardwire (H), and 10' Chevron Fog & Storm Braided (B) cord. • Available in Snow (SNW), Storm (STRM), & Black (BLK). • <i>Example: AUPWRMOD.AC.S.BLK</i> 	<p>\$ 761</p>
 <p>AURNDPWRMOD.AC.S</p>	<p>Power Module — Under Worksurface, Round 8¼"W x 16"D x 4½"H AURNDPWRMOD</p> <ul style="list-style-type: none"> • 2 receptacles, 1 USB-A, & 1 USB-C (AC) • 9' Straight cord only (S). • Available in Snow (SNW), Storm (STRM), & Black (BLK). • <i>Example: AURNDPWRMOD.AC.S.BLK</i> 	<p>\$ 713</p>
	<p>Triplex Circuit 1 Jumper Kit 48" ATPKIT48</p>	\$ 155
	<p>Triplex Circuit 1 Jumper Kit 60" ATPKIT60</p>	\$ 169
	<p>Triplex Circuit 1 Jumper Kit 72" ATPKIT72</p>	\$ 184
	<p>Triplex Circuit 2 Jumper Kit 48" ATPKIT482</p>	\$ 155
	<p>Triplex Circuit 2 Jumper Kit 60" ATPKIT602</p>	\$ 169
	<p>Triplex Circuit 2 Jumper Kit 72" ATPKIT722</p>	\$ 184
	<p>Triplex Corded Infeed 48" ATPCIF48</p>	\$ 212
	<p>Triplex Corded Infeed 72" ATPCIF72</p>	\$ 240
	<p>Triplex Hardwire Corded Infeed 72" ATPHWIF72</p>	\$ 184
	<p>Triplex H-Connector ATPSPLIT</p>	\$ 34

JETTY:MOD

<p>How to specify — Select the Model Number from above.</p>	<p>1st Option: Ports (Final port option if applicable): AC USB-A+C QA Wireless Charging with 1 USB-A port (+\$125)</p>	<p>2nd Option: Cord Type (Power Module cord type if applicable): S Straight Cord B Braided Chevron Fog & Storm Cord (+\$55) I Interlink Cord (+\$55) H Hardwire Cord (+\$106) Q Coiled Cord</p>	<p>3rd Option: Color Option (if applicable): SNW Snow STRM Storm BLK Black DWT White DGY Gray</p>
<p>_____ .</p>	<p>_____ .</p>	<p>_____ .</p>	<p>_____</p>

Example: AUPWRMOD.AC.S.SNW

[S] Shippable by small-package carrier.

**SUMMIT / PICNIC
PAINT FINISHES**

GRADE P1

Black	P71
Brownstone	P7D
Charblack	CBK
Designer White	PJW
Flint	P02
Fossil	P28
Loft	P7B
Muslin	P4J
Salt	P8C
Textured Designer White	PK7
Textured Brownstone	P7J
Textured Flint	P7A
Textured Loft	P7L
Textured Muslin	P7M
Textured Pebble	P8Y
Textured Salt	P8Z
Textured Titanium	P8V

GRADE P2

Matte Gold	P8G
Night Bronze	P8B
Solar Black	P8X
Pyrite	PJE
Silver	PR6

GRADE P3

Atom	P8S
Blossom***	P8K
Bullseye	PJF
Ember	P8P
Ion	P8N
Iris	P8J
Krypton	P8F
Ochre	P093
Regatta	P8M
Sienna	P092
Succulent***	P8A

**CLOUD
PAINT FINISHES**

GRADE P1

Charblack	CBK
Textured Designer White	PK7
Textured Brownstone	P7J
Textured Flint	P7A
Textured Loft	P7L
Textured Muslin	P7M
Textured Pebble	P8Y
Textured Salt	P8Z
Textured Titanium	P8V

GRADE P2

Textured Silver	PR8
Solar Black	P8X

***These colors are intended to be an inspirational option for the trending market. Production application is limited and color availability is approximately two years to coincide with evolving workplace trends.

LAMINATES

GRADE L1

ABSTRACT

Ash	LT3B
Handspun Pearl	LAHP
Handspun Dove	LAHD
Handspun Slate	LAHS
Handspun Chestnut	LAHC
Silver Mesh	LT8D

SOLID

Black	P
Brownstone	LM13
Bungalow	LM12
Designer White	LDW1
Flint	LM16
Fossil Shale	LEH1
Loft	LM11
Muslin	LM15
Titanium	LT11

WOODGRAIN

Belair	LWBA
Bourbon Cherry	H
Field Elm	LWFE
Florence Walnut	LFW1
Kingswood Walnut	LK11
Natural Maple	LWD
NeoWalnut	LNU1
Pinnacle	PINC
Shaker Cherry	LW7C

GRADE L2

WOODGRAIN

Beigewood	LWBE
Fawn Cypress	LFC1
Lowell Ash	LLA1
Mangalore Mango	LMM1
Natural Recon	LNR1
Phantom Charcoal	LPC1
Phantom Ecru	LPE1
Portico Teak	LPT1
Skyline Walnut	LSW1
Veranda Teak	LVT1

GRADE L3

WOODGRAIN

Natural Walnut	LWNW
----------------------	------

LAMINATE EDGE COLORS

Beigewood	DE
Belair	BA
Black	E4
Bourbon Cherry	H
Brownstone	EY
Bungalow	EX
Designer White	DW
Fawn Cypress	FC
Field Elm	FE
Flint	E9
Florence Walnut	FW
Fossil	EH
Kingswood Walnut	KI
Loft	EV
Lowell Ash	DL
Mangalore Mango	MM
Muslin	EU
Natural Maple	DD
Natural Recon	NR
Natural Walnut	DN
NeoWalnut	NU
Parchment	EN
Phantom Charcoal	PC
Phantom Ecru	PE
Pinnacle	PI
Platinum Metallic	EP
Portico Teak	DP
Shaker Cherry	DF
Skyline Walnut	SW
Titanium	TI
Veranda Teak	VT

NOTE: Refer to individual product pages for upcharges.

		Rock - Cushion	Rock - Shell/Body	Rock Single Upholstery	Peak Back	Peak Seat	Peak Single Upholstery	Peak Welt	Peak Ottoman	Wedge Seat	Wedge Back	Wedge Single Upholstery	Summit	Picnic Upholstered Seating
GRADE 1														
Apex	APX	•			•	•	•	•	•	•			•	•
Centurion	CU	•	•	•	•	•	•	•	•	•	•	•	•	•
Contourett	UR	•	•	•	•	•	•	•					•	•
Dapper	DAPR	•	•	•	•	•	•	•	•	•	•	•	•	•
Ensemble	ENSB	•	•	•	•	•	•	•	•	•	•	•	•	•
Hamilton <i>(De-emphasized)</i>	HAML	•	•	•	•	•	•	•	•	•	•	•	•	•
Inertia <i>(De-emphasized)</i>	NR	•	•	•	•	•	•	•	•	•	•	•	•	•
Optic <i>(De-emphasized)</i>	OP	•							•					
GRADE 2														
Appoint Seating	PNS	•	•	•	•	•	•	•	•	•	•	•	•	•
Blume	BLME	•	•	•	•	•	•	•	•	•	•	•	•	•
Clyde	CLYD	•	•	•	•	•	•	•	•	•	•	•	•	•
Dotty <i>(De-emphasized)</i>	DOT	•			•		•	•	•	•	•	•	•	•
Meld ⚡	SMHMLD	•	•	•	•	•	•	•	•	•	•	•	•	•
Rush	RUSH	•	•	•	•	•	•	•	•	•	•	•	•	•
Spin	SPNN	•			•				•				•	
Whisper Vinyl	WP	•	•	•	•	•	•	•	•				•	•
GRADE 3														
Lateral ⚡	SCFSLAT	•				•		•	•					
Moxie	SX	•	•	•	•	•	•	•	•				•	•
Purl	PURL	•	•	•	•	•	•	•	•	•	•	•	•	•
Quill	QUL	•			•	•	•	•	•				•	•
GRADE 4														
Caper ⚡	SMHMCAP	•	•	•		•		•	•					•
Manner ⚡	SMHMMAN	•	•	•	•	•	•	•	•	•	•	•	•	•
Merit ⚡	SMHMMER	•	•	•	•	•	•	•	•	•	•	•	•	•
Messenger ⚡	SMHMGRM	•	•	•				•	•	•	•	•	•	•
Metric ⚡	SMHMMET	•	•	•	•	•	•	•	•	•	•	•	•	•
Mode ⚡	SMHMMOD	•	•	•	•	•	•	•	•	•	•	•	•	•
Multiply ⚡	SMHMMLT					•		•	•					
Murmur ⚡	SMHMMUR	•			•	•	•	•	•				•	•
Muse ⚡	SMHMMUS	•	•	•		•		•	•	•	•	•	•	•
Trundle ⚡	SMHMTRN	•			•				•					•

TOWNHALL

⚡ Partnership Program — See page 10 for details.
 • Available upholstery option

- Allsteel fabrics and foam meet requirements for CTB117.
- Blank spaces indicate that a product has not yet been tested or that it failed.
- Contact Allsteel Customer Support for other flammability code approvals.

		Rock - Cushion	Rock - Shell/Body	Rock Single Upholstery	Peak Back	Peak Seat	Peak Single Upholstery	Peak Welt	Peak Ottoman	Wedge Seat	Wedge Back	Wedge Single Upholstery	Summit	Picnic Upholstered Seating
GRADE 5														
Main Line Flax ☎	SCAMMLF	•	•	•	•	•	•	•	•	•			•	•
Rove ☎	SMHMROV	•												
CF Stinson Sequence ☎	SCFSSEQ	•			•		•	•	•				•	•
GRADE 6														
Arris	ARR	•			•	•	•	•	•	•	•	•	•	•
Blazer ☎	SCAMBLZ	•	•	•	•	•	•	•	•	•	•	•	•	•
Chock ☎	SMHMCKK	•			•		•	•	•					
Hedge ☎	SMMHED	•	•	•	•		•	•	•					•
Hemp ☎	SCAMHMP	•	•	•	•	•	•	•	•	•	•			•
Pocket ☎	SMHMPKT	•	•	•		•		•	•	•				•
Maharam Sequence ☎	SMHMSQN	•			•		•	•						•
Tandem ☎	SMHMTAN	•			•		•	•	•					•
GRADE 7														
Silk ☎	SCAMSLK	•	•	•	•	•	•	•	•	•	•	•		•
GRADE 8														
Apt ☎	SMHMAPT	•	•	•	•	•	•	•	•					•
Brisa ☎	RS	•	•	•	•	•	•	•	•				•	•
Zap ☎	SCAMZAP	•	•	•	•	•	•	•	•	•	•	•	•	•
GRADE 9														
Ultraleather Pro ☎	SUF554	•	•	•	•	•	•	•	•				•	•
Yoredale ☎	SCAMYDL	•	•	•	•	•	•	•	•	•	•	•	•	•

☎ Partnership Program — See page 10 for details.
 • Available upholstery option

Upcharges listed for Grades 2 and above, add to Base Price. Grades 9-22 on page 318.

Style	Model Number <i>Add options below</i>	Base Price	Upholstery	Upcharge							
				2	3	4	5	6	7	8	
Peak Single Upholstery											
Peak Double Left Single Upholstery	ACVISDLS	\$ 4670	Seat/Back	\$ 149	\$ 295	\$ 441	\$ 635	\$ 831	\$ 1026	\$ 1219	
Peak Double Right Single Upholstery	ACVISDRS	\$ 4670	Seat/Back	\$ 149	\$ 295	\$ 441	\$ 635	\$ 831	\$ 1026	\$ 1219	
Peak Single Left Single Upholstery	ACVISSLS	\$ 3113	Seat/Back	\$ 75	\$ 148	\$ 220	\$ 317	\$ 415	\$ 510	\$ 608	
Peak Single Right Single Upholstery	ACVISSRS	\$ 3113	Seat/Back	\$ 75	\$ 148	\$ 220	\$ 317	\$ 415	\$ 510	\$ 608	
Peak Ottoman	ACVISOTS	\$ 2024	Body	\$ 64	\$ 124	\$ 185	\$ 267	\$ 348	\$ 431	\$ 511	
Peak Multi Upholstery											
Peak Double Left Multi Upholstery	ACVISDLM	\$ 4904	Seat	\$ 65	\$ 128	\$ 192	\$ 277	\$ 360	\$ 445	\$ 530	
			Back	\$ 56	\$ 111	\$ 165	\$ 237	\$ 309	\$ 383	\$ 456	
			Welt	\$ 37	\$ 73	\$ 109	\$ 156	\$ 203	\$ 250	\$ 298	
Peak Double Right Multi Upholstery	ACVISDRM	\$ 4904	Seat	\$ 65	\$ 128	\$ 192	\$ 277	\$ 360	\$ 445	\$ 530	
			Back	\$ 56	\$ 111	\$ 165	\$ 237	\$ 309	\$ 383	\$ 456	
			Welt	\$ 37	\$ 73	\$ 109	\$ 156	\$ 203	\$ 250	\$ 298	
Peak Single Left Multi Upholstery	ACVISSLM	\$ 3268	Seat	\$ 27	\$ 52	\$ 77	\$ 110	\$ 143	\$ 177	\$ 209	
			Back	\$ 31	\$ 61	\$ 92	\$ 132	\$ 173	\$ 214	\$ 253	
			Welt	\$ 22	\$ 44	\$ 65	\$ 93	\$ 121	\$ 150	\$ 179	
Peak Single Right Multi Upholstery	ACVISSRM	\$ 3268	Seat	\$ 27	\$ 52	\$ 77	\$ 110	\$ 143	\$ 177	\$ 209	
			Back	\$ 31	\$ 61	\$ 92	\$ 132	\$ 173	\$ 214	\$ 253	
			Welt	\$ 22	\$ 44	\$ 65	\$ 93	\$ 121	\$ 150	\$ 179	

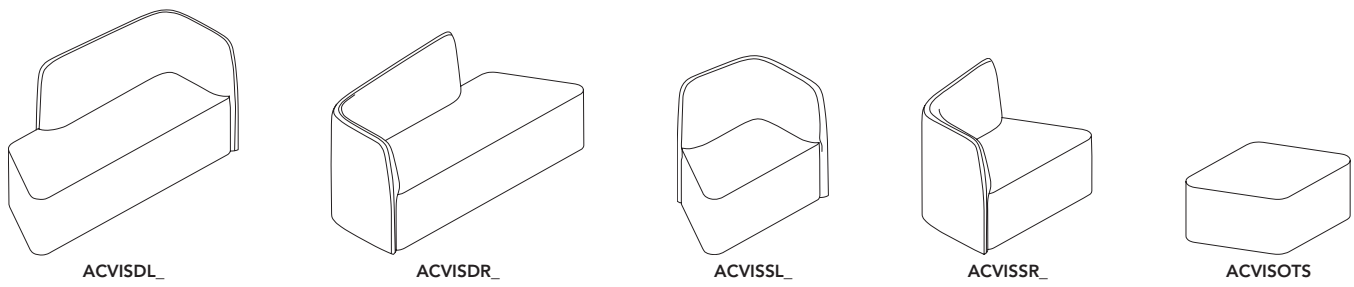

Pricing Example:	Model/Options	Base Price/Upcharges
Step 1: Select Model	ADVISDLM	\$ 4904
Step 2: Select Seat Upholstery	Grade 3	\$ 128 upcharge
Step 3: Select Back Upholstery	Grade 5	\$ 237 upcharge
Step 3: Select Welt Upholstery	Grade 1	\$ 0 upcharge
Add Base + applicable Upcharges for Total List Price =		\$ 5269

<p>How to specify — Select the Model Number from above.</p> <p>ACVIS S .</p>	<p><i>1st Option:</i> Select the Upholstery for Single Upholstery Models: See Allsteel Upholstery matrix on pages 202-203.</p> <p>_____ .</p>
---	---

Example: ACVISSRS.HAML11

<p>How to specify — Select the Model Number from above.</p> <p>ACVIS M .</p>	<p><i>1st Option:</i> Select the Seat Upholstery for Multi-Upholstery Models: See Allsteel Upholstery matrix on pages 202-203.</p> <p>_____ .</p>	<p><i>2nd Option:</i> Select the Back Upholstery for Multi-Upholstery Models: See Allsteel Upholstery matrix on pages 202-203.</p> <p>_____ .</p>	<p><i>3rd Option:</i> Select the Welt Upholstery for Multi-Upholstery Models: See Allsteel Upholstery matrix on pages 202-203.</p> <p>_____ .</p>
---	---	---	---

Example: ACVISDLM.CLYD13.RUSH18.HAML08

Model Number		Ship Weight	Calves	COM Yardage*	Overall			Seat			Arms			Backrest			
				Height	Width	Depth	Height	Width	Depth	Pan Angle (Range)	Armrest Height	Armrest Length	Arm Height to the Floor	Height	Width	Lumbar Height	Backrest angle (Range)
ACVISD_S	Seat/Back	220	55.6	8.6	38"	75½"	27½"										55.6
ACVISS_S	Seat/Back	160	31.3	4.5	38½"	43½"	27½"										31.3
ACVISOTS	Body	75	13.1	2.0	18¼"	40¼"	25½"										13.1
ACVISD_M	Seat	220	55.6	3.6	38"	75½"	27½"										55.6
	Back			3.1													
	Welt			2.0													
ACVISS_M	Seat	160	31.3	1.5	38½"	43½"	27½"										31.3
	Back			1.8													
	Welt			1.3													

*COM Yardage is listed for total yardage/feet required for a model, with applicable yardage/feet for individual components listed.



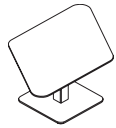

Description	Model <i>Add options below</i>	List Price with Upcharge			
		L1	L2	L3	
Peak Tables					
Peak Table	ACVISTBL	Table	\$ 2079	\$ 2127	\$ 2174
Peak Coffee Table	ACVISCTBL	Coffee Table	\$ 1919	\$ 1967	\$ 2014

Model Number	Overall				
	Ship Weight	Cubbs	Height	Width	Depth
ACVISTBL	50	8.7	27 1/2"	40 1/2"	25"
ACVISCTBL	45	6.1	17"	40 1/2"	25"

Peak Tables available in Knife Edge only.
Peak Coffee Table has the same outer dimensions as the Peak Ottoman.

TOWNHALL

<p>How to specify — Select the Model Number from above.</p>	<p>1st Option: Select FSC (if applicable):</p>	<p>2nd Option: Select the Laminate Color: See page 201 for selections and Color Codes.</p>	<p>3rd Option: Select the Edge Color: See page 201 for selections and Color Codes.</p>	<p>4th Option: Select the Paint Finish: P7A Textured Flint PR8 Textured Silver (Table) (Grade 2 upcharge \$54) PR8 Textured Silver (Coffee Table) (Grade 2 upcharge \$43) PK7 Textured Designer White</p>
<p>ACV I S .</p>	<p> .</p>	<p> .</p>	<p> .</p>	<p> </p>

Example: ACVISTBL.LM15.EU.PK7

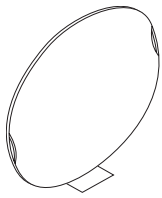

Description	Model <i>Add options below</i>	List Price with Upcharge	
		P1	P2
Cloud Screen			
Cloud Screen	ACDIV	\$ 2520	\$ 2690

Model Number	Cloud Screen	Ship Weight		COM Yardage*	Overall			Screen			Base Plate	
		Ctbs			Height	Width	Depth	Height	Width	Height	Width	Depth
ACDIV	Cloud Screen	66	8.8		72"	72"	22"	72"	72"	0.25"	17"	22"

<p>How to specify — Select the Model Number from above.</p>	<p>1st Option: Select the Upholstery: See Allsteel Upholstery matrix on pages 202-203. Cloud only offers Noble fabric.</p>	<p>2nd Option: Select the Paint Finish: See Paint Finishes on page 201.</p>
<p>A C D I V .</p>	<p> .</p>	<p> </p>

Example:

Upcharges listed for Grades 2 and above, add to Base Price. Grades 9-22 on page 318.

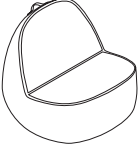
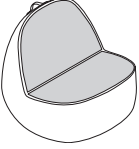
Style	Model Number <i>Add options below</i>	Base Price	Upholstery	Upcharge							
				2	3	4	5	6	7	8	
Rock											
Rock Single Upholstery	ACEGUS	\$ 2648	Cushion/Shell	\$ 82	\$ 162	\$ 244	\$ 353	\$ 460	\$ 569	\$ 677	
											
Rock											
Rock Multi Upholstery	ACEGUM	\$ 2779	Cushion Shell	\$ 42 \$ 57	\$ 82 \$ 115	\$ 122 \$ 170	\$ 177 \$ 247	\$ 230 \$ 322	\$ 285 \$ 398	\$ 339 \$ 473	
											

Note that handle is only available in single light gray leather.

Pricing Example:	Model/Options	Base Price/Upcharges
Step 1: Select Model	ACEGUM	\$ 2779
Step 2: Select Cushion Upholstery	Grade 4	\$ 122 upcharge
Step 3: Select Shell Upholstery	Grade 8	\$ 473 upcharge
Add Base + applicable Upcharges for Total List Price =		\$ 3374

TOWNHALL

How to specify — Select the Model Number from above.	<p><i>1st Option:</i> Select the Upholstery for Single Upholstery Models: See Allsteel Upholstery matrix on pages 202-203.</p>								
ACE G U S .	<table border="1" style="width: 100%; height: 20px;"> <tr> <td style="width: 12.5%;"></td> <td style="width: 12.5%;"></td> <td style="width: 12.5%;"></td> <td style="width: 12.5%;"></td> <td style="width: 12.5%;"></td> <td style="width: 12.5%;"></td> <td style="width: 12.5%;"></td> <td style="width: 12.5%;"></td> </tr> </table>								

Example: ACEGUS.CLYD08

How to specify — Select the Model Number from above.	<p><i>1st Option:</i> Select the Seat/Cushion Upholstery for Multi-Upholstery Models: See Allsteel Upholstery matrix on pages 202-203.</p>	<p><i>2nd Option:</i> Select the Shell/Body Upholstery for Multi-Upholstery Models: See Allsteel Upholstery matrix on pages 202-203.</p>																
ACE G U M .	<table border="1" style="width: 100%; height: 20px;"> <tr> <td style="width: 12.5%;"></td> <td style="width: 12.5%;"></td> <td style="width: 12.5%;"></td> <td style="width: 12.5%;"></td> <td style="width: 12.5%;"></td> <td style="width: 12.5%;"></td> <td style="width: 12.5%;"></td> <td style="width: 12.5%;"></td> </tr> </table>									<table border="1" style="width: 100%; height: 20px;"> <tr> <td style="width: 12.5%;"></td> <td style="width: 12.5%;"></td> <td style="width: 12.5%;"></td> <td style="width: 12.5%;"></td> <td style="width: 12.5%;"></td> <td style="width: 12.5%;"></td> <td style="width: 12.5%;"></td> <td style="width: 12.5%;"></td> </tr> </table>								

Example: ACEGUM.DAPR10.PNS006

Model Number		Ship Weight		COM Yardage*		Overall			Seat			Backrest			
		Calbs	COM Yardage*	Height	Width	Depth	Height	Width	Depth	Pan Angle (Range)	Height	Width	Backrest Inclination from Vertical	Backrest/Seat angle (Range)	
ACEGUS	Cushion/Shell	50	23.4	5.0	31"	31"	31"	14½"-19½"	29"	16½"	-1°-21°	21½"	29"	13°-33°	102°
ACEGUM	Cushion	50	23.4	3.5	31"	31"	31"	14½"-19½"	29"	16½"	-1°-21°	21½"	29"	13°-33°	102°
	Shell			2.5											

*COM Yardage is listed for total yardage/feet required for a model, with applicable yardage/feet for individual components listed.

TOWNHALL

Upcharges listed for Grades 2 and above, add to Base Price. Grades 9-22 on page 318.

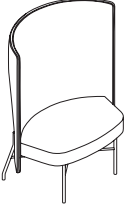
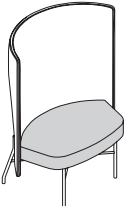
Style	Model Number <i>Add options below</i>	Base Price	Upholstery	Upcharge							
				2	3	4	5	6	7	8	
Wedge											
Wedge Single Upholstery	ACWEDS	\$ 3588	Seat/Back	\$ 65	\$ 130	\$ 195	\$ 282	\$ 368	\$ 455	\$ 541	
											
Wedge											
Wedge Multi Upholstery	ACWEDM	\$ 3767	Seat Back	\$ 17 \$ 49	\$ 32 \$ 97	\$ 49 \$ 147	\$ 71 \$ 211	\$ 92 \$ 277	\$ 115 \$ 341	\$ 135 \$ 406	
											

Pricing Example:	Model/Options	Base Price/Upcharges
Step 1: Select Model	ACWEDM	\$ 3767
Step 2: Select Seat Upholstery	Grade 4	\$ 49 upcharge
Step 3: Select Back Upholstery	Grade 1	\$ 0 upcharge
Add Base + applicable Upcharges for Total List Price =		\$ 3816

<p>How to specify — Select the Model Number from above.</p> <p>ACWEDS .</p>	<p>1st Option: Select the Upholstery for Single Upholstery Models: See Allsteel Upholstery matrix on pages 202-203.</p> <p>_____ .</p>	<p>2nd Option: Select the Paint Finish: P71 Black P JW Designer White P02 Flint PJE Pyrite (Grade 2 upcharge \$248) PR6 Silver (Grade 2 upcharge \$248) PJF Bullseye (Grade 3 upcharge \$618)</p> <p>_____ .</p>
<p><i>Example: ACWEDS.DOT90.P02</i></p>		

<p>How to specify — Select the Model Number from above.</p> <p>ACWEIDM .</p>	<p>1st Option: Select the Seat Upholstery for Multi-Upholstery Models: See Allsteel Upholstery matrix on pages 202-203.</p> <p>_____ .</p>	<p>2nd Option: Select the Back Upholstery for Multi-Upholstery Models: See Allsteel Upholstery matrix on pages 202-203.</p> <p>_____ .</p>	<p>3rd Option: Select the Paint Finish: P71 Black P JW Designer White P02 Flint PJE Pyrite (Grade 2 upcharge \$260) PR6 Silver (Grade 2 upcharge \$260) PJF Bullseye (Grade 3 upcharge \$650)</p> <p>_____ .</p>
<p><i>Example: ACWEDM.HAML18.NR66.PR6</i></p>			

TOWNHALL

Model Number		Ship Weight		COM Yardage*	Overall			Seat			Backrest			
		Cubes	Height		Width	Depth	Height	Width	Depth	Pan Angle (Range)	Width	Lumbar Height	Backrest/Seat Angle (Range)	
ACWEDS	Seat/Back	85	28.5	4.0	46 1/2"	48"	25 1/2"	17 1/2"	31"	19 1/2"	0°	15"	10"	0°
ACWEDM	Seat	85	28.5	1.0										
	Back			3.0										

*COM Yardage is listed for total yardage/feet required for a model, with applicable yardage/feet for individual components listed.



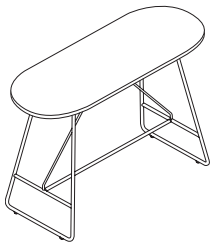

Description	Model <i>Add options below</i>	List Price			Paint Upcharge	
		L1	L2	L3	P2	P3
Picnic Table						
Picnic Table, Bar Height	ACPICT	\$ 2398	\$ 2418	\$ 2435	\$ 133	\$ 331

Picnic Table						
Picnic Table, Bar Height	ACPICT30	\$ 2478	\$ 2501	\$ 2523	\$ 133	\$ 331

TOWNHALL

<p>How to specify — Select the Model Number from above.</p> <p>ACPICT . .</p>	<p>1st Option: Select FSC (if applicable):</p> <p> .</p>	<p>2nd Option: Select the Laminate Finish: See page 344 for selections and Color Codes.</p> <p> .</p>	<p>3rd Option: Select the Edge Color: See page 344 for selections and Color Codes.</p> <p> .</p>	<p>4th Option: Select the Paint Finish: See Paint Finishes on page 344.</p> <p>P1 P2 P3 P2 add \$133 Table P3 add \$331 Table</p> <p> .</p>
--	--	---	--	--

Example: ACPICT.LDW1.DW.P71

Model Number					Overall			Seat			
		Ship Weight	Cables	COM Yardage*	Height	Width	Depth	Height	Width	Depth	Pan Angle (Range)
ACPICT	Table	80	11.3		41"	64"	24"				
ACPICT30	Table	103	9.1		41"	64"	30"				

*COM Yardage is listed for total yardage/feet required for a model, with applicable yardage/feet for individual components listed.

Upcharges listed for Grades 2 and above, add to Base Price. Grades 9-22 on page 318.

Description	Model Number <i>Add options below</i>	List Price with Upcharge							
		1	2	3	4	5	6	7	8
Summit Stools									
Summit Stool	ACPERU	\$ 992	\$ 1001	\$ 1009	\$ 1016	\$ 1028	\$ 1038	\$ 1049	\$ 1060



Summit Stool stacks 4 high.

Model Number	Stool	Overall			Seat				Backrest						
		Ship Weight	Cutbs	COM Yardage*	Height	Width	Depth	Height	Width	Depth	Pan Angle (Range)	Height	Width	Backrest Inclination from vertical	Backrest/Seat Angle (Range)
ACPERU		0.5	0.5	0.5	33"	18"	17"	28"	0	13"	0°-3°	5 1/4"	0"	27°-30°	117°

*COM Yardage is listed for total yardage/feet required for a model, with applicable yardage/feet for individual components listed.

<p>How to specify — Select the Model Number from above.</p>	<p>1st Option: Select the Upholstery: See Allsteel Upholstery matrix on pages 202-203.</p>	<p>2nd Option: Select the Paint Finish: See Paint Finishes on page 201. P1 P2 P3 P2 add \$74 upcharge P3 add \$184 upcharge</p>
<p>ACPERU .</p>	<p></p>	<p></p>

Example: ACPERU.DOT24.P02

Alone-Together Solo

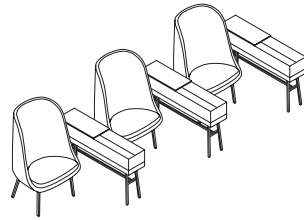

AIRPORT LOUNGE

Open Social Collaborative

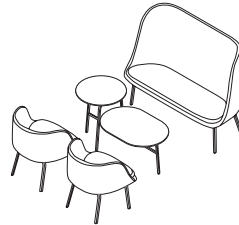

COLLABORATIVE WORK LOUNGE

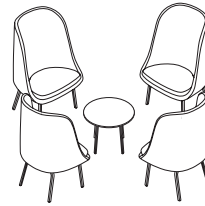

SPACE DEFINING LOUNGE
(4 PERSON)

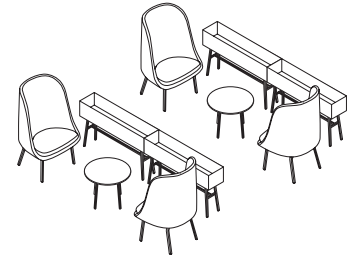

SPACE DEFINING LOUNGE
(2 PERSON)

Kit-of-Parts

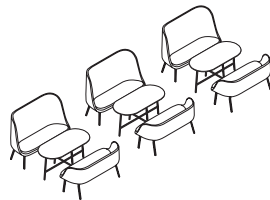

SPACE DEFINING BANQUETTE

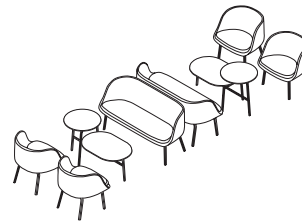

BACK-TO-BACK LOUNGE

Re-deployable Space Division

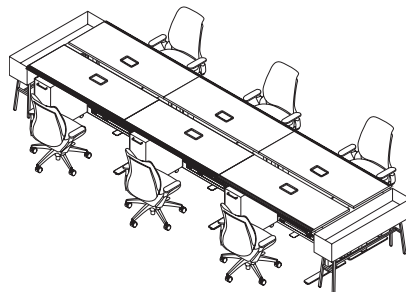

END-OF-RUN

LAMINATES

GRADE L1-ABSTRACT

Ash.....	LT3B
Handspun Pearl.....	LAHP
Handspun Dove.....	LAHD
Handspun Slate.....	LAHS
Handspun Chestnut.....	LAHC
Silver Mesh.....	LT8D

GRADE L1-SOLID

Black.....	P
Brownstone.....	LM13
Bungalow.....	LM12
Designer White.....	LDW1
Flint.....	LM16
Fossil Shale.....	LEH1
Loft.....	LM11
Muslin.....	LM15
Titanium.....	LT11

GRADE L1-WOODGRAIN

Belair.....	LWBA
Bourbon Cherry.....	H
Field Elm.....	LWFE
Florence Walnut.....	LFW1
Kingswood Walnut.....	LK11
Natural Maple.....	LWD
NeoWalnut.....	LNU1
Pinnacle.....	PINC
Shaker Cherry.....	LW7C

GRADE L2-WOODGRAIN

Beigewood.....	LWBE
Fawn Cypress.....	LFC1
Lowell Ash.....	LLA1
Mangalore Mango.....	LMM1
Natural Recon.....	LNRR1
Phantom Charcoal.....	LPC1
Phantom Ecru.....	LPE1
Portico Teak.....	LPT1
Skyline Walnut.....	LSW1
Veranda Teak.....	LVT1

GRADE L3-WOODGRAIN

Natural Walnut.....	LWNW
---------------------	------

GRADE L4-MARKERBOARD

White Markerboard.....	FMQ1
------------------------	------

GRADE L7-SOLID (TRACELESS)*†

Black Velvet.....	LBV1
Charcoal Velvet.....	LCV1

* Park Storage is available in all grades of laminate except Grades 4 and 7.

† LBV1 and LCV1 are warranted for 1 year.

EDGES

Beigewood.....	DE
Belair.....	BA
Black.....	E4
Bourbon Cherry.....	H
Brownstone.....	EY
Bungalow.....	EX
Designer White.....	DW
Fawn Cypress.....	FC
Field Elm.....	FE
Flint.....	E9
Florence Walnut.....	FW
Fossil.....	EH
Kingswood Walnut.....	KI
Loft.....	EV
Lowell Ash.....	DL
Mangalore Mango.....	MM
Muslin.....	EU
Natural Maple.....	DD
Natural Recon.....	NR
Natural Walnut.....	DN
NeoWalnut.....	NU
Parchment.....	EN
Phantom Charcoal.....	PC
Phantom Ecru.....	PE
Pinnacle.....	PI
Portico Teak.....	DP
Shaker Cherry.....	DF
Skyline Walnut.....	SW
Titanium.....	TI
Veranda Teak.....	VT

PAINT

GRADE P1

Textured Brownstone.....	P7J
Textured Designer White.....	PK7
Textured Flint.....	P7A
Textured Loft.....	P7L
Textured Muslin.....	P7M
Textured Pebble.....	P8Y
Textured Salt.....	P8Z
Textured Titanium.....	P8V

GRADE P2

Textured Silver.....	PR8
Solar Black.....	P8X

GRADE P3

Atom.....	P85
Blossom***.....	P8K
Ember.....	P8P
Ion.....	P8N
Iris.....	P8J
Krypton.....	P8F
Ochre.....	P093
Regatta.....	P8M
Sienna.....	P092
Succulent***.....	P8A

***These colors are intended to be an inspirational option for the trending market. Production application is limited and color availability is approximately two years to coincide with evolving workplace trends.

WOOD FINISH

WOOD SPECIES

STAIN NAME MAPLE

Beigewood.....	LE878
Belair.....	LE934
Burnished Cherry.....	LE777
Cinnamon Cherry.....	LE260
Clear Coat.....	LE100
Clear Oak.....	LE300
Clear/Natural Maple.....	LE800
Dark Rift Cut Oak.....	LE331
Ebony Maple.....	LE555
Field Elm.....	LE599
Florence Walnut.....	LE579
Harvest Maple.....	LE856
Light Cherry.....	LE701
Light Walnut.....	LE601
Lowell Ash.....	LE394
Medium Red Cherry.....	LE512
Natural Cherry.....	LE222
Nutmeg Walnut.....	LE629
Phantom Ecru.....	LE912
Pinnacle Walnut.....	LE679
Portico Teak.....	LE150
Shaker Cherry.....	LE774
Skyline Walnut.....	LE625
Sumatra Walnut.....	LE693

Natural variances in wood grains and color shades are expected in all wood finishes.

All of Allsteel's tables are level® - 2 certified to the ANSI/BIFMA e3 Furniture Sustainability Standard. See www.levelcertified.org for more information.

NOTE: Refer to individual product pages for upcharges.

FSC Certified Wood at Allsteel
See page 459 for more information.

Allsteel Seating Upholstery Selections by Model/Series.

			Seat Upholstery	Seat & Back Upholstery
GRADE 1				
Apex	APX		•	
Centurion	CU		•	•
Contourett	UR		•	•
Dapper	DAPR		•	•
Ensemble	ENSB		•	•
Hamilton <i>(De-emphasized)</i>	HAML		•	•
Inertia <i>(De-emphasized)</i>	NR		•	•
Optic <i>(De-emphasized)</i>	OP		•	
GRADE 2				
Appoint Seating	PNS		•	•
Blume	BLME		•	•
Clyde	CLYD		•	•
Dotty <i>(De-emphasized)</i>	DOT		•	•
Meld	SMHMLD		•	•
Rush	RUSH		•	•
Spin	SPNN		•	
Whisper Vinyl	WP		•	•
GRADE 3				
Lateral	SCFSLAT		•	
Moxie	SX		•	•
Purl	PURL		•	•
Quill	QUL		•	•
GRADE 4				
Caper	SMHMCAP		•	
Manner	SMHMMAN		•	•
Merit	SMHMMER		•	•
Messenger	SMHMGRM		•	•
Metric	SMHMMET		•	•
Mode	SMHMMOD		•	•
Trundle	SMHMTRN		•	

			Seat Upholstery	Seat & Back Upholstery
GRADE 5				
Main Line Flax	SCAMMLF		•	•
Riddle	SCFSRID		•	
Stinson Sequence	SCFSSEQ		•	
GRADE 6				
Arris	ARR		•	
Blazer	SCAMBLZ		•	•
Chock	SMHMCK		•	
Hedge	SMHMHE		•	
Hemp	SCAMHMP		•	•
Pocket	SMHMCKT		•	
Tandem	SMHMTAN		•	
GRADE 7				
Silk	SCAMSLK		•	•
GRADE 8				
Brisa	RS		•	•
Zap	SCAMZAP		•	•
GRADE 9				
Ultraleather Pro	SUF554		•	•
Yoredale	SCAMYDL		•	•

⊕ Partnership Program — See page 10 for details.
 • Available upholstery option

- Allsteel fabrics and foam meet requirements for CTB117.
- Blank spaces indicate that a product has not yet been tested or that it failed.
- Contact Allsteel Customer Support for other flammability code approvals.

(See page 318 for COM pricing on Grades 9-22)

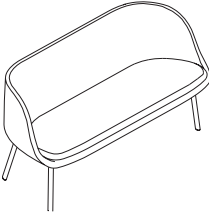
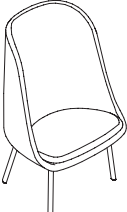
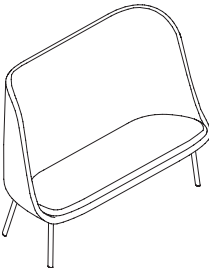
Description	Model Number <i>Add options below</i>	Base Price	Upholstery	Upcharge								
				2	3	4	5	6	7	8		
Park Single Upholstery												
	Park Lo Solo Lounge, Metal Leg	NALS	\$ 3373	Upholstery	\$ 40	\$ 79	\$ 118	\$ 171	\$ 223	\$ 276	\$ 329	
	Park Lo Solo Lounge, Wood Leg	NALSW	\$ 4118	Upholstery	\$ 40	\$ 79	\$ 118	\$ 171	\$ 223	\$ 276	\$ 329	
	Park Lo Settee Lounge, Metal Leg	NALD	\$ 5509	Upholstery	\$ 55	\$ 111	\$ 165	\$ 239	\$ 312	\$ 386	\$ 459	
	Park Lo Settee Lounge, Wood Leg	NALDW	\$ 6303	Upholstery	\$ 55	\$ 111	\$ 165	\$ 239	\$ 312	\$ 386	\$ 459	
	Park Hi Solo Lounge, Metal Leg	NAHS	\$ 4405	Upholstery	\$ 55	\$ 111	\$ 165	\$ 239	\$ 312	\$ 386	\$ 459	
	Park Hi Solo Lounge, Wood Leg	NAHSW	\$ 5150	Upholstery	\$ 55	\$ 111	\$ 165	\$ 239	\$ 312	\$ 386	\$ 459	
	Park Hi Settee Lounge, Metal Leg	NAHD	\$ 7403	Upholstery	\$ 79	\$ 157	\$ 236	\$ 342	\$ 446	\$ 552	\$ 657	
	Park Hi Settee Lounge, Wood Leg	NAHDW	\$ 8197	Upholstery	\$ 79	\$ 157	\$ 236	\$ 342	\$ 446	\$ 552	\$ 657	

How to specify —
Select the Model Number from above.

1st Option:

Select the Base Paint or Wood Finish:

P1 P2

Grade 2 upcharge: Solo \$24 / Settee \$26

2nd Option:

Select the Upholstery:

See Allsteel Upholstery matrix on page 13-14.

N | A | .

. | . | . | .

. | . | . | . | . | . | . | .

Example: NALS.P7L.SCAMBLZ24

Model Number	Ship Weight		COM Yardage*	Overall			Seat			Back				
	Calbs			Height	Width	Depth	Height	Width	Depth	Pan Angle (Range)	Height	Width	Lumbar Height	Backrest angle (Range)
NALS	50	39.4	2.5	31½"	32"	27½"	18¼"	21"	19½"	3"	17½"	15"	8¼"	107"
NALSW	52	39.4	2.5	31½"	32"	27½"	18¼"	21"	19½"	3"	17½"	15"	8¼"	107"
NALD	80	82.2	4.5	31½"	64"	27½"	18¼"	55¼"	19½"	3"	17½"	48"	8¼"	107"
NALDW	85	82.2	4.5	31½"	64"	27½"	18¼"	55¼"	19½"	3"	17½"	48"	8¼"	107"
NAHS	65	55.9	3.5	48½"	32"	27½"	18¼"	21"	19½"	3"	32"	15"	8¼"	107"
NAHSW	67	55.9	3.5	48½"	32"	27½"	18¼"	21"	19½"	3"	32"	15"	8¼"	107"
NAHD	105	116.1	5	48½"	64"	27½"	18¼"	55¼"	19½"	3"	32"	48"	8¼"	107"
NAHDW	110	116.1	5	48½"	64"	27½"	18¼"	55¼"	19½"	3"	32"	48"	8¼"	107"

*COM Yardage is listed for total yardage/feet required for a model, with applicable yardage/feet for individual components listed.

(See page 318 for COM pricing on Grades 9-22)

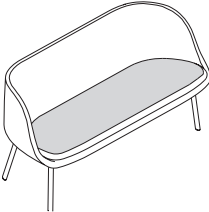
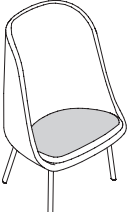
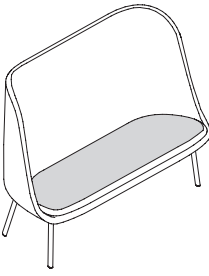
Description	Model Number <i>Add options below</i>	Base Price	Upholstery	Upcharge							
				2	3	4	5	6	7	8	
Park Multi-Upholstery											
	Park Lo Solo Lounge	NALSM	\$ 3546	Back	\$ 31	\$ 63	\$ 94	\$ 137	\$ 178	\$ 221	\$ 262
	Multi Upholstery, Metal Leg			Seat	\$ 8	\$ 16	\$ 23	\$ 34	\$ 44	\$ 55	\$ 66
	Park Lo Solo Lounge	NALSMW	\$ 4291	Back	\$ 31	\$ 63	\$ 94	\$ 137	\$ 178	\$ 221	\$ 262
	Multi Upholstery, Wood Leg			Seat	\$ 8	\$ 16	\$ 23	\$ 34	\$ 44	\$ 55	\$ 66
	Park Lo Settee Lounge	NALDM	\$ 5783	Back	\$ 45	\$ 91	\$ 137	\$ 198	\$ 259	\$ 320	\$ 381
	Multi Upholstery, Metal Leg			Seat	\$ 15	\$ 29	\$ 43	\$ 62	\$ 80	\$ 100	\$ 118
	Park Lo Settee Lounge	NALDMW	\$ 6577	Back	\$ 45	\$ 91	\$ 137	\$ 198	\$ 259	\$ 320	\$ 381
	Multi Upholstery, Wood Leg			Seat	\$ 15	\$ 29	\$ 43	\$ 62	\$ 80	\$ 100	\$ 118
	Park Hi Solo Lounge	NAHSM	\$ 4629	Back	\$ 45	\$ 91	\$ 137	\$ 198	\$ 259	\$ 320	\$ 381
	Multi Upholstery, Metal Leg			Seat	\$ 15	\$ 29	\$ 43	\$ 62	\$ 80	\$ 100	\$ 118
	Park Hi Solo Lounge	NAHSMW	\$ 5374	Back	\$ 45	\$ 91	\$ 137	\$ 198	\$ 259	\$ 320	\$ 381
	Multi Upholstery, Wood Leg			Seat	\$ 15	\$ 29	\$ 43	\$ 62	\$ 80	\$ 100	\$ 118
	Park High Settee Lounge	NAHDM	\$ 7773	Back	\$ 45	\$ 91	\$ 137	\$ 198	\$ 259	\$ 320	\$ 381
	Multi Upholstery, Metal Leg			Seat	\$ 33	\$ 66	\$ 100	\$ 143	\$ 188	\$ 232	\$ 276
	Park High Settee Lounge	NAHDMW	\$ 8567	Back	\$ 45	\$ 91	\$ 137	\$ 198	\$ 259	\$ 320	\$ 381
	Multi Upholstery, Wood Leg			Seat	\$ 33	\$ 66	\$ 100	\$ 143	\$ 188	\$ 232	\$ 276

Pricing Example:	Model/Options	Base Price/Upcharges
Step 1: Select Model	NALSM	\$ 3546
Step 2: Select Paint	P8X	\$ 24 upcharge
Step 3: Select Back Upholstery	Grade 5	\$ 137 upcharge
Step 4: Select Seat Upholstery	Grade 2	\$ 8 upcharge
Add Base + applicable Upcharges for Total List Price =		\$ 3715

<p>How to specify — Select the Model Number from above.</p> <p>_____ .</p>	<p>1st Option: Select the Base Paint or Wood Finish:</p> <p>P1 P2 Grade 2 upcharge: Solo \$24 / Settee \$26</p> <p>_____ .</p>	<p>2nd Option: Select the Back Upholstery for Multi-Upholstery Models:</p> <p>See Allsteel Upholstery matrix on page 13-14.</p> <p>_____ .</p>	<p>3rd Option: Select the Seat Upholstery for Multi-Upholstery Models:</p> <p>See Allsteel Upholstery matrix on page 13-14.</p> <p>_____ .</p>
---	--	---	---

Examples: NALSM.P8X.HAML10.RUSH07

PARK

Model Number	Overall			Seat				Back							
	Ship Weight	Calbs	COM Yardage*	Height	Width	Depth	Height	Width	Depth	Pan Angle (Range)	Height	Width	Lumbar Height	Backrest angle (Range)	
NALSM	50	39.4	2	31½"	32"	27½"	Back					17½"	15"	8¼"	107"
			0.5				Seat	18¼"	21"	19½"	3"				
NALSMW	52	39.4	2	31½"	32"	27½"	Back					17½"	15"	8¼"	107"
			0.5				Seat	18¼"	21"	19½"	3"				
NALDM	80	82.2	3.5	31½"	64"	27½"	Back					17½"	48"	8¼"	107"
			1				Seat	18¼"	55¼"	19½"	3"				
NALDMW	85	82.2	3.5	31½"	64"	27½"	Back					17½"	48"	8¼"	107"
			1				Seat	18¼"	55¼"	19½"	3"				
NAHSM	65	55.9	3	48½"	32"	27½"	Back					32"	15"	8¼"	107"
			0.5				Seat	18¼"	21"	19½"	3"				
NAHSMW	67	55.9	3	48½"	32"	27½"	Back					32"	15"	8¼"	107"
			0.5				Seat	18¼"	21"	19½"	3"				
NAHDM	105	116.6	4	48½"	64"	27½"	Back					32"	48"	8¼"	107"
			1				Seat	18¼"	55¼"	19½"	3"				
NAHDMW	110	116.6	4	48½"	64"	27½"	Back					32"	48"	8¼"	107"
			1				Seat	18¼"	55¼"	19½"	3"				

*COM Yardage is listed for total yardage/feet required for a model, with applicable yardage/feet for individual components listed.



Description	Model Number <i>below</i>	Cubes	Weight					Grade 2 Paint Upcharge
				L1	L2	L3	L7	
Park Lo Side Table								
19 1/4"H x 24"W x 24"D	NARC	10.0	20	\$1058	\$1082	\$1106	\$1201	\$ 30

Pricing Example:	Model/Options	Base Price/Upcharges
Step 1: Select Model	NARC	
Step 2: Select Laminate	w/Grade 3 Laminate	\$ 1106
Step 3: Select Paint	Grade 2 Paint	\$ 30 upcharge
Add Base + applicable Upcharges for Total List Price =		\$ 1136

<p>How to specify — Select the Model Number from above.</p> <p>N A </p> <p> .</p>	<p>1st Option: Select FSC (if applicable):</p> <p> .</p>	<p>2nd Option: Select the Paint Finish:</p> <p>P1 P2</p> <p> .</p>	<p>3rd Option: Select the Laminate Color:</p> <p>See page 216 for selections and color codes.</p> <p> .</p>	<p>4th Option: Select the Edge Color:</p> <p>See page 216 for selections and color codes.</p> <p> </p>
--	--	--	---	---

Example: NARC.FSC.P8Z.LFC1.FC





Description	Model Number <i>below</i>	Cubes	Weight					Grade 2 Paint Upcharge
				L1	L2	L3	L7	
Park Lo Pill Table								
20 1/4" H x 48" W x 15" D	NA4815RB	11.0	35	\$1082	\$1106	\$1130	\$1225	\$ 36
Park Hi Pill Table								
29 1/4" H x 48" W x 15" D	NA4828RB	14.6	50	\$1208	\$1232	\$1256	\$1351	\$ 45

<p>How to specify — Select the Model Number from above.</p> <p>NA </p> <p> .</p>	<p>1st Option: Select FSC (if applicable):</p> <p> .</p>	<p>2nd Option: Select the Paint Finish:</p> <p>P1 P2</p> <p> .</p>	<p>3rd Option: Select the Laminate Color:</p> <p>See page 216 for selections and color codes.</p> <p> .</p>	<p>4th Option: Select the Edge Color:</p> <p>See page 216 for selections and color codes.</p> <p> </p>
---	--	--	---	---

Example: NA4815RB.FSC.P8X.LWBA.BA

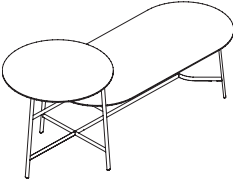

Description	Model Number <i>Add options below</i>	Cubes	Weight					Grade 2 Paint Upcharge
				L1	L2	L3	L7	
 <p>Park Pill Work Table 28½"H x 57"W x 27"D</p>	NAPWT	18.9	45	\$2186	\$2244	\$2302	\$2531	\$ 56
 <p>Park Hi Lo Casual Table 28½"H x 52¼"W x 24"D</p>	NALC	25.7	52	\$2275	\$2339	\$2400	\$2649	\$ 44
 <p>Park Hi Lo Meeting Table 41"H x 107¼"W x 42"D</p>	NALCF	34.8	146	\$6562	\$6689	\$6812	\$7307	\$ 259

Pricing Example:	Model/Options	Base Price/Upcharges
Step 1: Select Model	NALC	
Step 2: Select Laminate	w/Grade 3 Laminate	\$ 2400
Step 3: Select Paint	Grade 2 Paint	\$ 44 upcharge
Add Base + applicable Upcharges for Total List Price =		\$ 2444

<p>How to specify — Select the Model Number from above.</p> <p>N A </p>	<p>1st Option: Select FSC (if applicable):</p> <p> .</p>	<p>2nd Option: Select the Paint Finish:</p> <p>P1 P2</p> <p> .</p>	<p>3rd Option: Select the Laminate Color:</p> <p>See page 216 for selections and color codes.</p> <p> .</p>	<p>4th Option: Select the Edge Color:</p> <p>See page 216 for selections and color codes.</p> <p> .</p>	<p>5th Option: Select whether Grommet (Park Hi Lo Meeting Table only):</p> <p>N No grommet G Grommet (\$13 upcharge)</p> <p> .</p>	<p>6th Option: Select the Grommet Color (Park Hi Lo Meeting Table only):</p> <p>E4 Black E9 Flint DW Designer White EV Loft EU Muslin TI Titanium</p> <p> </p>
---	--	--	---	---	--	---

Example: NALCF.FSC.LWBA.BA.G.E9

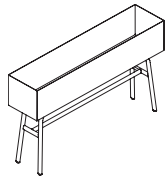

Description	Model Number <i>Add options below</i>	Cubes	Ship Weight	Base List Price	Grade 2
					Paint Upcharge
Park Planters — Lo Plant/Storage Pedestal 28 3/4" H x 48 3/4" W x 11" D	NALP	6.5	53	\$ 1444	\$ 82

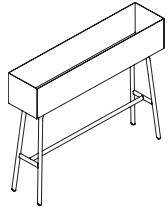

Park Planters — Hi Plant/Storage Pedestal 38 3/4" H x 48 3/4" W x 11" D	NAHP	10.1	58	\$ 1607	\$ 91
---	------	------	----	---------	-------

<p>How to specify — Select the Model Number from above.</p> <p>N A .</p>	<p>1st Option: Select the Paint Finish:</p> <p>(P1) (P2)</p> <p> </p>
---	--

Example: NALP.P8X

Description	Model <i>Add options below</i>	Cubes	Weight	L1	L2	L3
				Pedestal Planter Park Laminate Plant/Storage Pedestal Top	NAPT	1.1

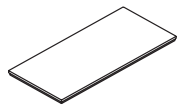

<p>How to specify — Select the Model Number from above.</p> <p>N A P T .</p>	<p>1st Option: Select FSC (if applicable):</p> <p> .</p>	<p>2nd Option: Select the Laminate Color:</p> <p>See page 216 for selections and color codes.</p> <p> .</p>	<p>3rd Option: Select the Edge Color:</p> <p>See page 216 for selections and color codes.</p> <p> </p>
---	--	---	---

Example: NAPT.LWBA.EV



**RECHARGE
PAINT FINISHES**

TABLE BASES

- Textured Designer WhitePK7
- Textured FlintP7A
- Textured SilverPR8

**RECHARGE SCREEN
FABRICS**

- Dark Grey DRK
- Light GreyLGT
- Medium Grey MDD

**RECHARGE CONNECTOR
TABLE LAMINATES**

- Designer WhiteLDW1
- FlintLM16

**RECHARGE
TABLE LAMINATES**

GRADE L1

SOLID COLOR

- Black P
- BrownstoneLM13
- BungalowLM12
- Designer WhiteLDW1
- FlintLM16
- Fossil ShaleLEH1
- LoftLM11
- MuslinLM15
- TitaniumLTI1

ABSTRACT

- AshLT3B
- Handspun PearlLAHP
- Handspun DoveLAHD
- Handspun SlateLAHS
- Handspun ChestnutLAHC
- Silver MeshLT8D

WOODGRAIN

- BelairLWBA
- Bourbon Cherry H
- Field ElmLWFE
- Florence WalnutLFW1
- Kingswood WalnutLK11
- Natural MapleLWD
- NeoWalnutLNU1
- PinnaclePINC
- Shaker CherryLW7C

GRADE L2

WOODGRAIN

- BeigewoodLWBE
- Fawn CypressLFC1
- Lowell AshLLA1
- Mangalore MangoLMM1
- Natural ReconLNR1
- Phantom CharcoalLPC1
- Phantom EcuLPE1
- Portico TeakLPT1
- Skyline WalnutLSW1
- Veranda TeakLVT1

GRADE L3

WOODGRAIN

- Natural WalnutLWNW

RECHARGE EDGE COLORS

- Beigewood DE
- BelairBA
- Black E4
- Bourbon Cherry H
- BrownstoneEY
- BungalowEX
- Designer WhiteDW
- Fawn CypressFC
- Field ElmFE
- Flint E9
- Florence WalnutFW
- FossilEH
- Kingswood WalnutKI
- LoftEV
- Lowell AshDL
- Mangalore MangoMM
- MuslinEU
- Natural MapleDD
- Natural ReconNR
- Natural WalnutDN
- NeoWalnutNU
- ParchmentEN
- Phantom CharcoalPC
- Phantom EcuPE
- PinnaclePI
- PlybandPL
- Portico TeakDP
- Shaker CherryDF
- Skyline WalnutSW
- TitaniumTI
- Veranda TeakVT

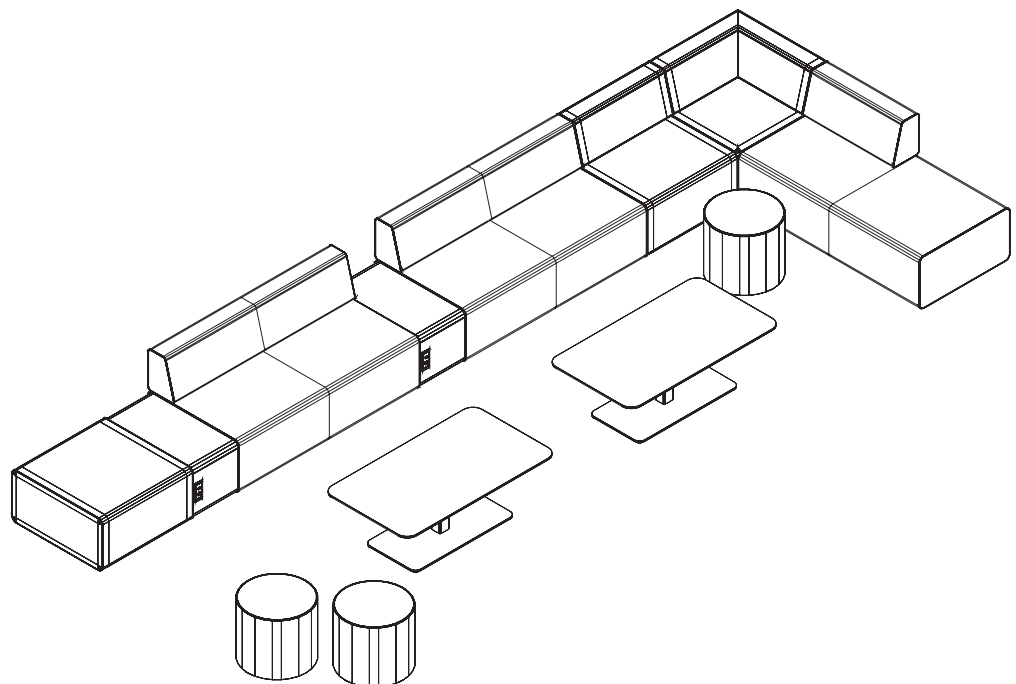

		Recharge Pouf - Seat, Side, Welt	Recharge Bolster	Recharge Bolster Welt	Recharge Seat	Recharge Seat Welt
GRADE 1						
Apex	APX	•	•	•	•	•
Centurion	CU	•				
Contourett	UR	•	•	•	•	•
Dapper	DAPR	•	•	•	•	•
Ensemble	NSB	•	•	•	•	•
Hamilton <i>(De-emphasized)</i>	HAML	•	•	•	•	•
Inertia <i>(De-emphasized)</i>	NR	•	•	•	•	•
GRADE 2						
Appoint Seating	PNS	•	•	•	•	•
Blume	BLME	•	•	•	•	•
Clyde	CLYD	•	•	•	•	•
Dotty <i>(De-emphasized)</i>	DOT	•	•	•	•	•
Meld ⚡	SMHMLD	•	•	•	•	•
Rush	RUSH	•	•	•	•	•
Spin Seating	SPNN	•	•	•	•	•
Whisper Vinyl	WP	•	•	•	•	•
GRADE 3						
Lateral ⚡	SCFSLAT	•	•	•	•	•
Moxie	SX	•	•	•	•	•
Parker	PRKR	•	•	•	•	•
Purl	PURL	•	•	•	•	•
Quill	QUL	•	•	•	•	•
GRADE 4						
Blink	1048	•	•	•	•	•
Caper ⚡	SMHMCAP	•				
Look-See	1044	•	•	•	•	•
Manner ⚡	SMHMMAN	•	•	•	•	•
Messenger ⚡	SMHMGRM	•	•	•	•	•
Metric ⚡	SMHMMET	•	•	•	•	•
Mode ⚡	SMHMMOD	•	•	•	•	•
Murmur ⚡	SMHMMUR	•				
Muse ⚡	SMHMMUS	•			•	
Trundle ⚡	SMHMTRN	•				
Walkabout	1046	•	•	•	•	•

		Recharge Pouf - Seat, Side, Welt	Recharge Bolster	Recharge Bolster Welt	Recharge Seat	Recharge Seat Welt
GRADE 5						
Checkmate	1043	•	•	•	•	•
Main Line Flax ⚡	SCAMMLF	•	•	•	•	•
CF Stinson Sequence ⚡	SCFSSEQ	•	•	•	•	•
Zippy	1045	•	•	•	•	•
GRADE 6						
Arris	ARR	•	•		•	
Blazer ⚡	SCAMBLZ	•	•	•	•	•
Hemp ⚡	SCAMHMP	•	•	•	•	•
Poppy ⚡	1047	•	•	•	•	•
GRADE 7						
Silk ⚡	SCAMSLK	•	•	•	•	•
GRADE 8						
Apt ⚡	SMHMAPT	•	•	•	•	•
Brisa ⚡	RS	•	•	•	•	•
Zap ⚡	SCAMZAP	•	•	•	•	•
GRADE 9						
Ultraleather Pro ⚡	SUF554	•	•	•	•	•
Yoredale ⚡	SCAMYDL	•	•	•	•	•

⚡ Partnership Program — See page 10 for details.

- Available upholstery option
- Allsteel fabrics and foam meet requirements for CTB117.
- Blank spaces indicate that a product has not yet been tested or that it failed.
- Contact Allsteel Customer Support for other flammability code approvals.

Designed in partnership with Chris Adamick, Recharge includes soft seating pieces and tables that can be integrated for private, public, or collaborative settings.

MODELS AND OPTIONS

Recharge seating is available in four different options: Pouf, Bench, Bench with Bolster, and Bench with Bolster and Screen. Bolsters are available as full width, half-width, and as corner units providing a large array of configurations.

Recharge Tables can stand alone or allow connection of seating components to create straight or 120-degree configurations. Power options are also available.

APPLICATIONS

Use Recharge as booths, micro-environments or bench seating in café areas, lobbies, open plan, atrium spaces, or reception areas.

KEY FEATURES

Recharge modular lounge seating is constructed of fabric covered foam with upholstery-grade FSC plywood core and box joints.

Each bench has glides that can be adjusted up to 2".

MATERIALS

- All COMs/COLs must be approved for upholsterability. See pages 6-8 for COM ordering instructions.

OPTIONS — MODULAR LOUNGE SEATING

Description:

Bench — Single or Double width seats (no back bolster)

Bench with Bolsters — Single or Double width seats with full, half, or corner bolsters

Bench with Bolsters and Screens — Single or Double width seats with full, half, or corner bolsters and full width or full width and 3/4 side screens.

Poufs (mini ottomans) — Round or Square seat

FSC Certified Wood:

FSC FSC Certified Wood

Bench Seat Upholstery:

See page 228 for upholstery selections.

Bench Seat Welt Cord Upholstery:

See page 228 for upholstery selections.

Bolster Upholstery:

See page 228 for upholstery selections.

Bolster Welt Cord Upholstery:

See page 228 for upholstery selections.

OPTIONS — MODULAR LOUNGE CONNECTORS AND TABLES

Description:

Connector Tables — Straight or 120-Degree

Tables — Coffee, Work, or Corner

Laptop Table

Connector Tables

L1 Designer White and Flint

Laminate Table Tops

L1 Solid Color, Abstract, and Woodgrain Laminate

L2 Woodgrain Laminate

L3 Woodgrain Laminate

See page 227 for laminate finishes and codes

Painted Table Base

See page 227 for paint finishes and codes

OPTIONS — ELECTRICAL

Description:

Electrical ports are available on seat benches and connector tables with corded, 4-Wire Kits, or hard wire options. See pages 232-233 for specifications and examples. See page 243 for electrical components.

A full gallery of typicals can be found on our website: <https://www.allsteeloffice.com/design-resources/idea-starters>.
 Each typical includes a complete BOM with current pricing, downloadable CAD files, and PDFs of each drawing.

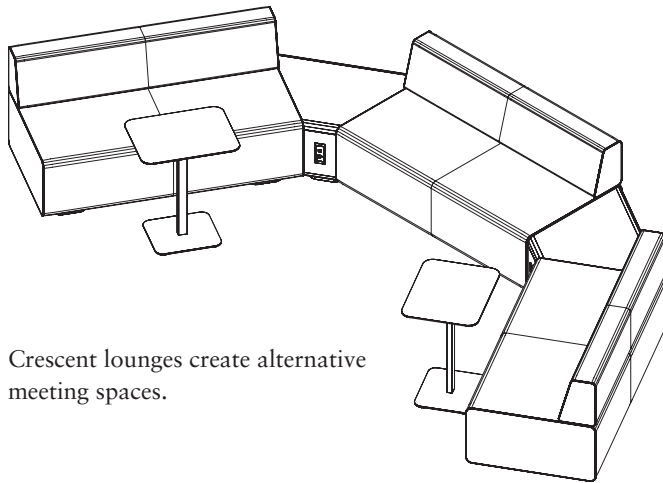

Crescent lounges create alternative meeting spaces.

Private booths are familiar, cafe-like work settings.

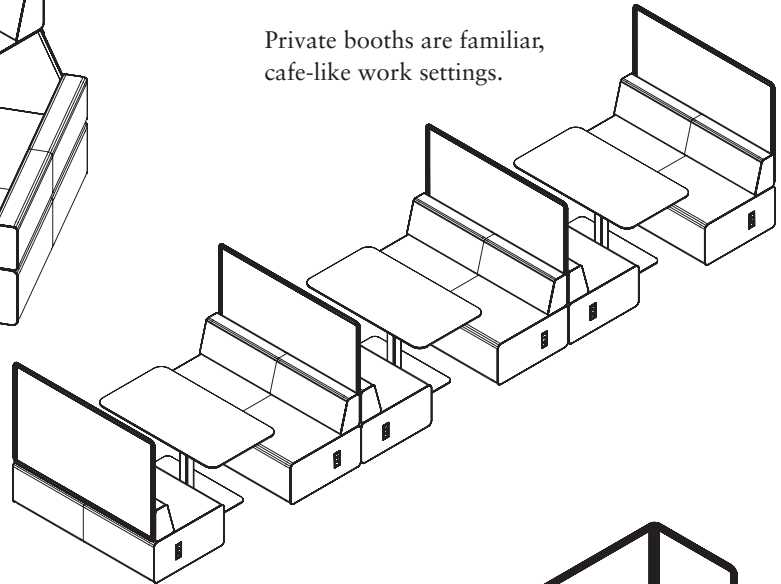

Clusters provide seating options and power for common spaces.

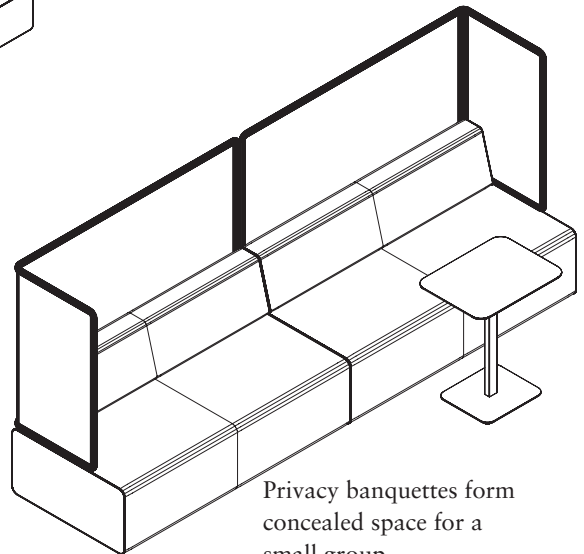
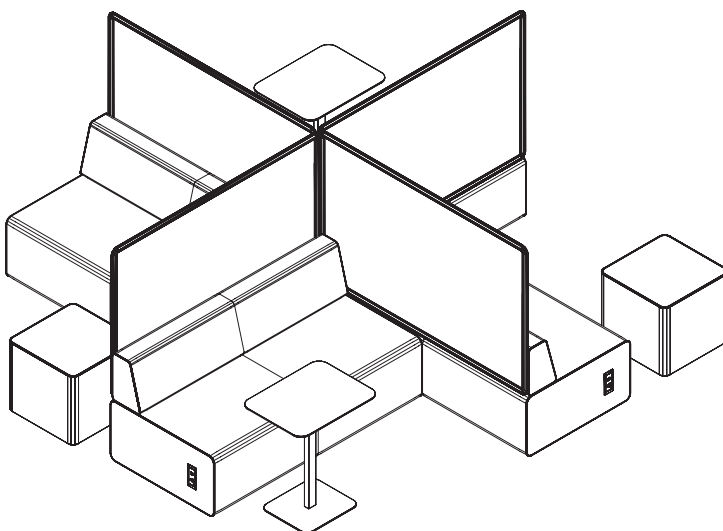

Privacy banquettes form concealed space for a small group.

Sofas offer space to think away from the desk.

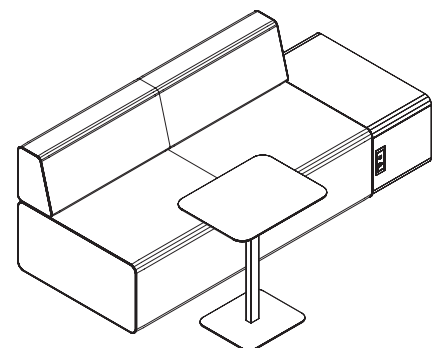

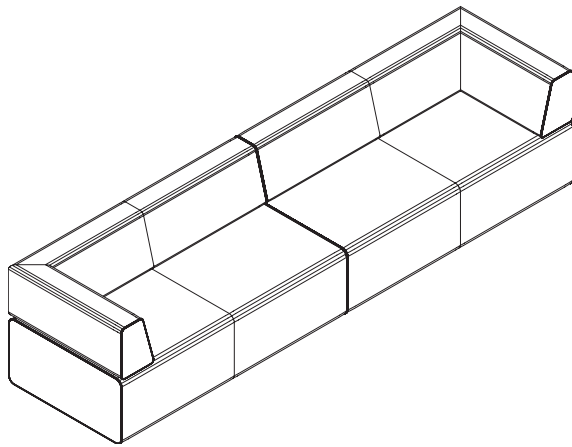

Sectional sofas easily scale up or down in length.

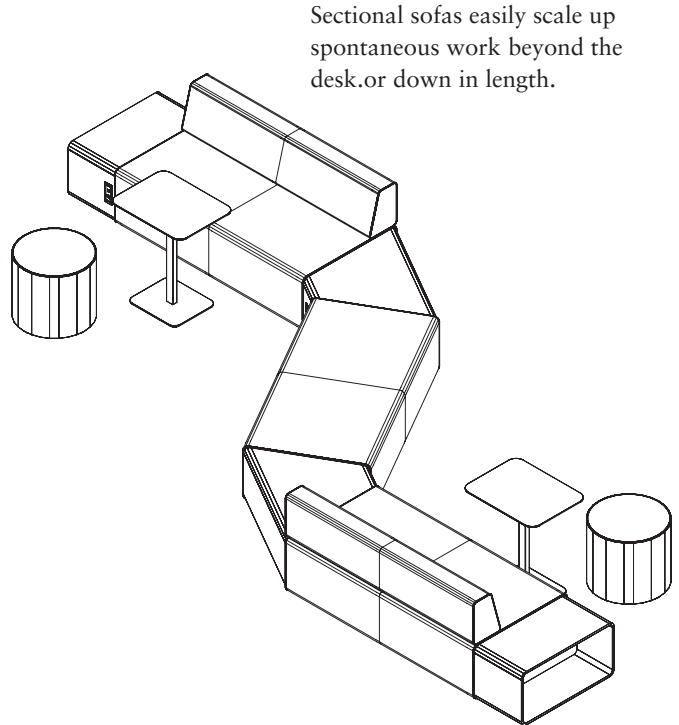

Sectional sofas easily scale up spontaneous work beyond the desk, or down in length.

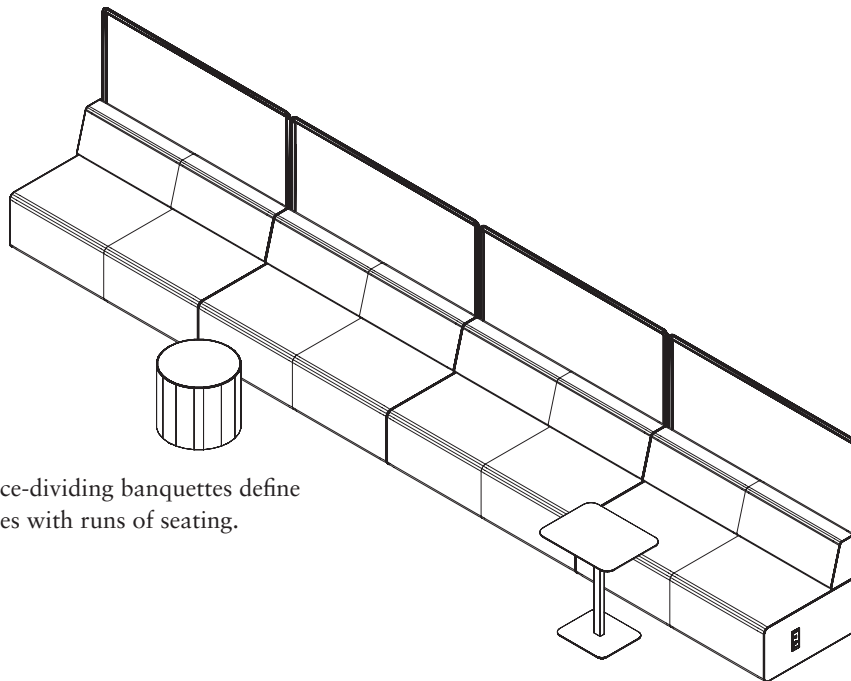

Space-dividing banquettes define zones with runs of seating.

Sectional return sofas turn 90 degree corners.

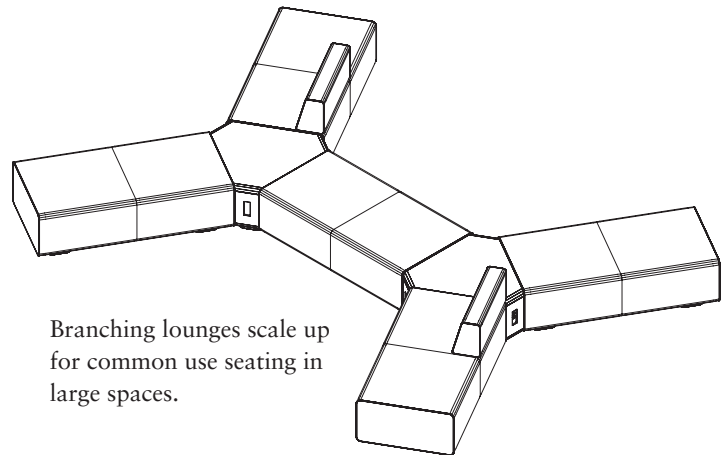
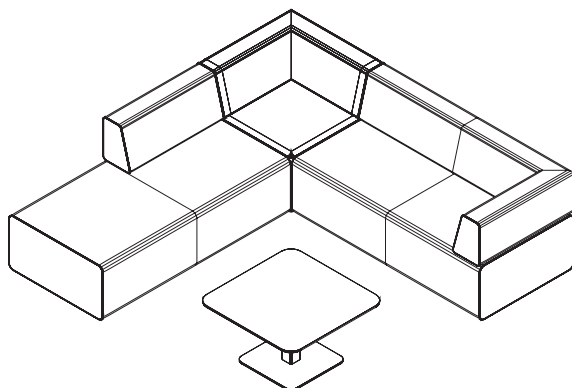

Branching lounges scale up for common use seating in large spaces.

POWER-READY MODELS

Recharge power-ready Bench models and Connector Tables have cut-out(s) that will accept Recharge Power Ports (ordered separately).

Electrical cutout on the soft seating pieces is located on the side or in the front of the unit. The opening is 1.94" W x 6.25" H.

All Connector Tables come with or without an electrical cutout in them. The 120° x 3 Connector Table has three electrical cutouts, while the 120° x 2 and Straight Connector Tables have one electrical cutout. Electrical components need to be ordered separately from the units.

Recharge Power Ports are UL listed. All power modules have 2 simplex and 2 USB outlets. Three power options with cords are available:

- Corded – plugs a single unit into standard outlet
- Hardwire – connects a single unit to power source by a licensed electrician
- 4-Wire used for powering multiple units – requires 4-Wire Infeed Kit. 4-Wire Jumper Kit(s) may also be required when powering multiple units from the same Infeed. See examples.

It's the customer's responsibility to ensure that installation and use of the electrical system, the number of receptacles used on a given circuit, and connections to the building power supply meets all local and national electrical codes.

STEPS FOR ORDERING RECHARGE 4-WIRE POWER KITS:

1. Determine the number and location of powered ports in configuration. A maximum of thirteen Recharge ports can be connected on one Infeed.
2. Order one 4-Wire Power Port for each powered Recharge Unit.
3. Order one Infeed Kit. Each Infeed Kit includes H-Connector which can power either:
 - 3 Recharge units
 - 2 Recharge units and 1 Jumper
 - 1 Recharge unit and 2 Jumpers
 - 3 Jumpers
4. Determine if Jumper with H-Connector Kits are needed for connecting multiple powered Recharge units.
 - A Jumper Kit is required if the distance between the H-Connector on the end of Infeed or Jumper is greater than 72" to the Power Port cutout on the Recharge unit.
 - Jumper Kits are available in 42" and 72" lengths.
 - Infeeds and Jumpers can't plug directly into Power Port.

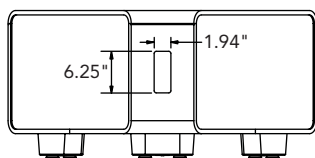

Front View of 120° Connector Table

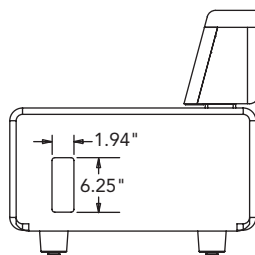

Side View of Soft Seating

ELECTRICAL EXAMPLE 1 — 2 variations

- 2 – 4-Wire Power Ports
- 1 – Infeed Kit

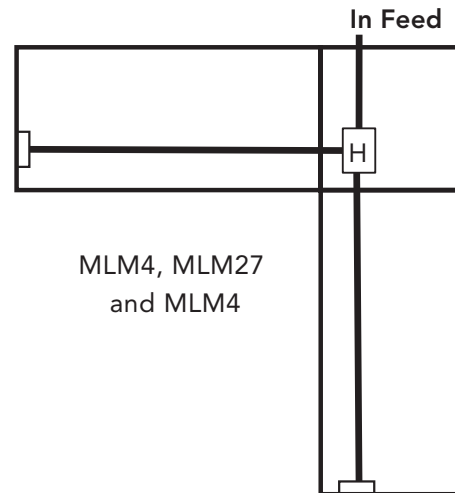
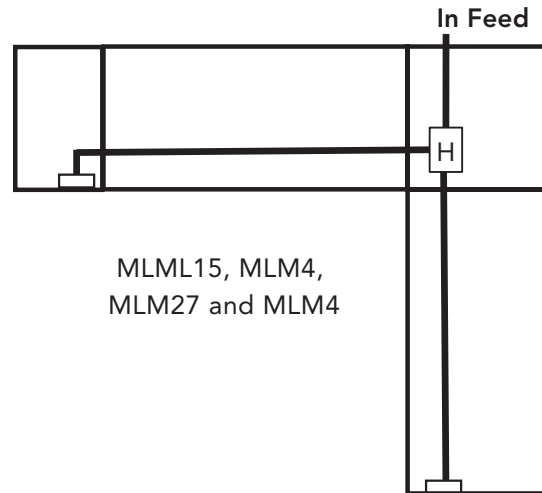
**ELECTRICAL EXAMPLE 2**

- Any soft seating with 2 MLM16's (120 x 2 connectors)
- 2 – 4-Wire Power Ports
- 1 – Infeed Kit

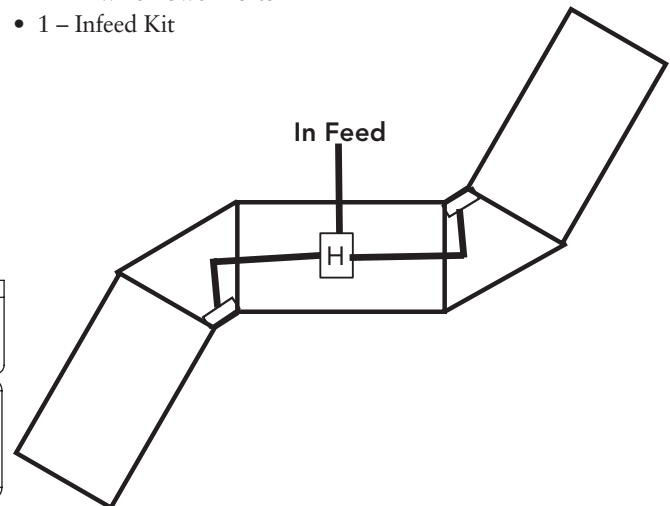

ELECTRICAL EXAMPLE 3

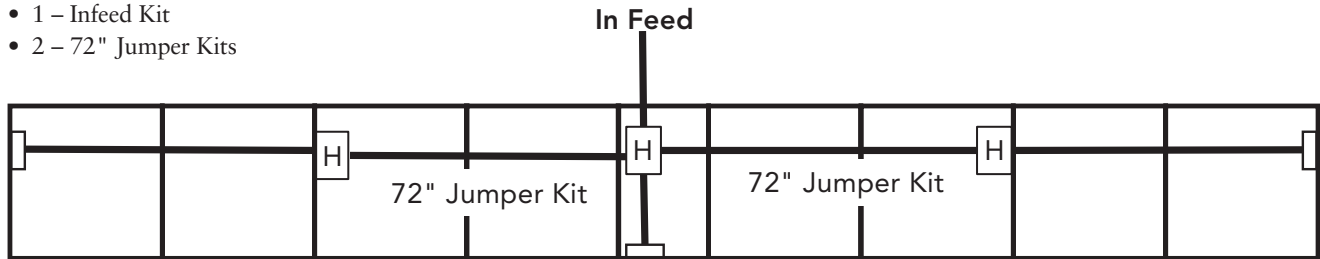

- MLM1's and/or MLM2's with a MLM15 (straight connector table in the middle).
- 3 – 4-Wire Power Ports
- 1 – Infeed Kit
- 2 – 72" Jumper Kits

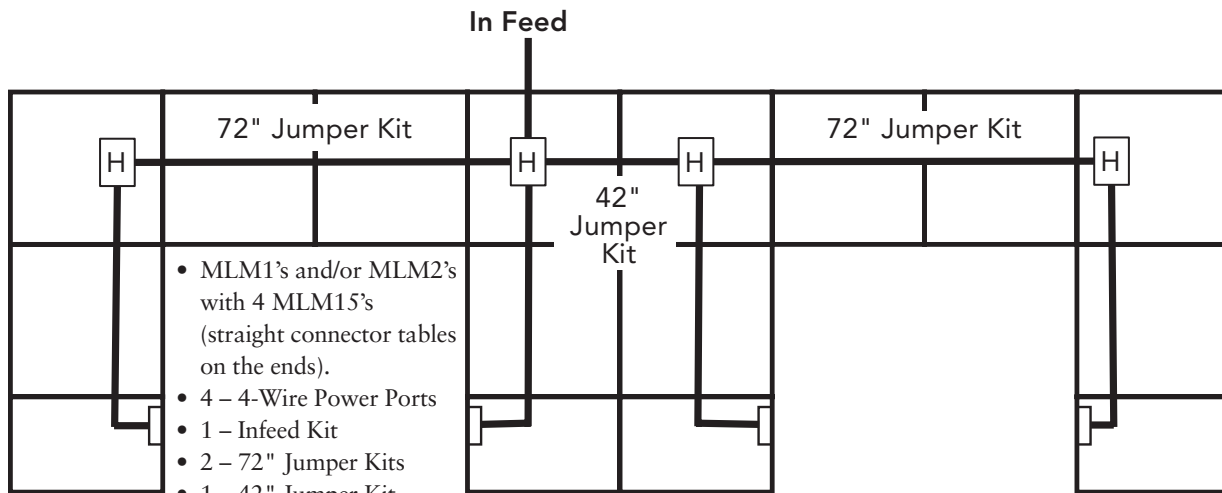

ELECTRICAL EXAMPLE 4

- MLM1's and/or MLM2's with 4 MLM15's (straight connector tables on the ends).
- 4 – 4-Wire Power Ports
- 1 – Infeed Kit
- 2 – 72" Jumper Kits
- 1 – 42" Jumper Kit

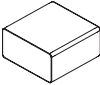
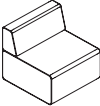
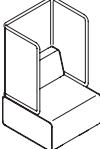
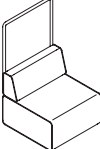

Style	Description	Model Number <i>Add options below</i>	Base Price	Upholstery Upcharges	Upcharge							
					2	3	4	5	6	7	8	L1
Poufs & Single Seats												
	Single Upholstery	MLM20S	\$ 719	Upholstery	\$ 43	\$ 87	\$ 131	\$ 190	\$ 248	\$ 307	\$ 366	\$ 845
	Multi Upholstery	MLM20	\$ 756	Seat	\$ 12	\$ 26	\$ 38	\$ 55	\$ 71	\$ 88	\$ 105	\$ 242
				Welt	\$ 16	\$ 31	\$ 47	\$ 68	\$ 89	\$ 111	\$ 131	\$ 304
				Side	\$ 20	\$ 41	\$ 62	\$ 89	\$ 116	\$ 143	\$ 171	\$ 394
	Single Upholstery	MLM21S	\$ 719	Upholstery	\$ 43	\$ 87	\$ 131	\$ 190	\$ 248	\$ 307	\$ 366	\$ 845
	Multi Upholstery	MLM21	\$ 756	Seat	\$ 12	\$ 26	\$ 38	\$ 55	\$ 71	\$ 88	\$ 105	\$ 242
				Welt	\$ 16	\$ 31	\$ 47	\$ 68	\$ 89	\$ 111	\$ 131	\$ 304
				Side	\$ 20	\$ 41	\$ 62	\$ 89	\$ 116	\$ 143	\$ 171	\$ 394
	Matching Welt	MLM1S	\$ 2030	Seat	\$ 65	\$ 130	\$ 196	\$ 282	\$ 369	\$ 456	\$ 543	\$ 1255
	Contrast Welt	MLM1	\$ 2137	Seat	\$ 52	\$ 104	\$ 156	\$ 225	\$ 295	\$ 363	\$ 433	\$ 1001
				Seat Welt	\$ 20	\$ 41	\$ 62	\$ 89	\$ 116	\$ 143	\$ 171	\$ 394
	Matching Welt	MLM2S	\$ 2587	Seat	\$ 65	\$ 130	\$ 196	\$ 282	\$ 369	\$ 456	\$ 543	\$ 1255
				Bolster	\$ 32	\$ 65	\$ 98	\$ 141	\$ 184	\$ 228	\$ 271	\$ 627
	Contrast Welt	MLM2	\$ 2724	Seat	\$ 52	\$ 104	\$ 156	\$ 225	\$ 295	\$ 363	\$ 433	\$ 1001
				Seat Welt	\$ 20	\$ 41	\$ 62	\$ 89	\$ 116	\$ 143	\$ 171	\$ 394
				Bolster	\$ 20	\$ 41	\$ 62	\$ 89	\$ 116	\$ 143	\$ 171	\$ 394
	Matching Welt	MLM36S	\$ 4174	Seat	\$ 65	\$ 130	\$ 196	\$ 282	\$ 369	\$ 456	\$ 543	\$ 1255
				Bolster	\$ 32	\$ 65	\$ 98	\$ 141	\$ 184	\$ 228	\$ 271	\$ 627
	Contrast Welt	MLM36	\$ 4383	Seat	\$ 52	\$ 104	\$ 156	\$ 225	\$ 295	\$ 363	\$ 433	\$ 1001
				Seat Welt	\$ 20	\$ 41	\$ 62	\$ 89	\$ 116	\$ 143	\$ 171	\$ 394
				Bolster	\$ 20	\$ 41	\$ 62	\$ 89	\$ 116	\$ 143	\$ 171	\$ 394
	Matching Welt	MLM37S	\$ 3701	Seat	\$ 65	\$ 130	\$ 196	\$ 282	\$ 369	\$ 456	\$ 543	\$ 1255
				Bolster	\$ 32	\$ 65	\$ 98	\$ 141	\$ 184	\$ 228	\$ 271	\$ 627
	Contrast Welt	MLM37	\$ 3885	Seat	\$ 52	\$ 104	\$ 156	\$ 225	\$ 295	\$ 363	\$ 433	\$ 1001
				Seat Welt	\$ 20	\$ 41	\$ 62	\$ 89	\$ 116	\$ 143	\$ 171	\$ 394
				Bolster	\$ 20	\$ 41	\$ 62	\$ 89	\$ 116	\$ 143	\$ 171	\$ 394
			Bolster Welt	\$ 16	\$ 31	\$ 47	\$ 68	\$ 89	\$ 111	\$ 131	\$ 304	

Example of upcharges: Model MLM2 with Grade 5 Seat, Grade 2 Seat Welt, Grade 1 Bolster, and Grade 2 Bolster Welt = \$2724 + \$225 + \$20 + \$0 + \$16 = **\$2985 Total**

Continued on next page ►

<p>How to specify — Select the Model Number from above.</p>	<p>1st Option FSC Certified Wood: FSC Select for FSC certified wood</p>	<p>2nd Option Select the Power Cutout Option (if applicable): N No Power Cutout L Left Side (\$39 extra) R Right Side (\$39 extra) FL Front Left (\$39 extra) FR Front Right (\$39 extra)</p>	<p>3rd Option Select the Seat Upholstery: See page 228 for selections and color codes. See Seating Price List for COM Guidelines.</p>	<p>4th Option Select the Seat Welt Cord Upholstery (if applicable): See page 228 for selections and color codes.</p>	<p>5th Option: Select the Bolster Upholstery (if applicable): See page 228 for selections and color codes.</p>
<p>MLM . F S C </p>					

Examples: MLM20S.FSC.SCAMBLZ24 MLM36.FSC.FL.SHBFBCV90.PURL08.SHBFBCV80.PURL08.MDD

Model Number		Overall			Seat			Backrest				Ship Weight	Cubes			
		COM Yardage	COL Sq. Feet	Height	Width	Depth	Height	Width	Depth	Ran Angle	Height			Width	Lumbar Height	Backrest/Seat Angle
MLM20S	Full Unit	2.75	—	17¼"	19"	19"	17¼"	19"	19"	—					15	5.3
MLM20	Seat	0.5	—	17¼"	19"	19"	17¼"	19"	19"	—					15	5.3
	Welt	1.0	—													
	Side	1.25	—													
MLM21S	Full Unit	2.75	—	17¼"	19"	19"	17¼"	19"	19"	—					15	5.3
MLM21	Seat	0.5	—	17¼"	19"	19"	17¼"	19"	19"	—					15	5.3
	Welt	1.0	—													
	Side	1.25	—													
MLM1S	Full Unit	4.5	—	17¼"	29"	29"	17¼"	29"	29"	—					75	25.5
MLM1	Seat	3.25	—	17¼"	29"	29"	17¼"	29"	29"	—					75	25.5
	Seat Welt	1.25	—													
MLM2S	Seat	4.5	—	28¾"	29"	29"	17¼"	29"	20"	—	11½"	29"	8½"	101°	95	25.5
	Bolster	2.5	—													
MLM2	Seat	3.25	—	28¾"	29"	29"	17¼"	29"	20"	—	11½"	29"	8½"	101°	95	25.5
	Seat Welt	1.25	—													
	Bolster	1.5	—													
	Bolster Welt	1.0	—													
MLM36S	Seat	4.5	—	53¾"	29"	29"	17¼"	29"	20"	—	11½"	29"	8½"	101°	86	30.8
	Bolster	2.5	—													
MLM36	Seat	3.25	—	53¾"	29"	29"	17¼"	29"	20"	—	11½"	29"	8½"	101°	86	30.8
	Seat Welt	1.25	—													
	Bolster	1.5	—													
	Bolster Welt	1.0	—													
MLM37S	Seat	4.5	—	53¾"	29"	29"	17¼"	29"	20"	—	11½"	29"	8½"	101°	74	30.8
	Bolster	2.5	—													
MLM37	Seat	3.25	—	53¾"	29"	29"	17¼"	29"	20"	—	11½"	29"	8½"	101°	74	30.8
	Seat Welt	1.25	—													
	Bolster	1.5	—													
	Bolster Welt	1.0	—													

*COM Yardage is listed for total yardage required for a model, with applicable yardage for individual components listed below each total: Seat, Seat Welt, Bolster, and Bolster Welt. If the same upholstery material is used for all components, use just the bold total yardage that aligns with the model number.

◀ Continued from previous page

<p>6th Option: Select the Bolster Welt Cord Upholstery (if applicable): See page 228 for selections and color codes.</p>	<p>7th Option: Select the Screen Color (if applicable): LGT Light Gray MDD Medium Gray DRK Dark Gray</p>
--	---

(See page 319 for COM pricing on Grades 9-22)

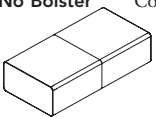
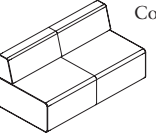
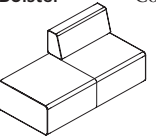
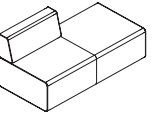
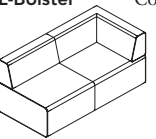
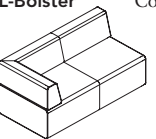
Style	Description	Model Number <i>Add options below</i>	Base Price	Upholstery Upcharges	Upcharge							
					2	3	4	5	6	7	8	L1
Double Seats												
Double	Matching Welt	MLM3S	\$ 2586	Seat	\$ 89	\$ 178	\$ 268	\$ 387	\$ 506	\$ 625	\$ 744	\$ 1719
No Bolster	Contrast Welt	MLM3	\$ 2748	Seat	\$ 79	\$ 157	\$ 236	\$ 342	\$ 446	\$ 552	\$ 657	\$ 1517
				Welt	\$ 20	\$ 41	\$ 62	\$ 89	\$ 116	\$ 143	\$ 171	\$ 394
Double With	Matching Welt	MLM4S	\$ 3845	Seat	\$ 89	\$ 178	\$ 268	\$ 387	\$ 506	\$ 625	\$ 744	\$ 1719
Double Bolster	Contrast Welt	MLM4	\$ 4047	Bolster	\$ 46	\$ 93	\$ 140	\$ 202	\$ 264	\$ 327	\$ 390	\$ 901
				Seat	\$ 79	\$ 157	\$ 236	\$ 342	\$ 446	\$ 552	\$ 657	\$ 1517
				Seat Welt	\$ 20	\$ 41	\$ 62	\$ 89	\$ 116	\$ 143	\$ 171	\$ 394
				Bolster	\$ 36	\$ 72	\$ 108	\$ 157	\$ 205	\$ 253	\$ 302	\$ 698
				Bolster Welt	\$ 16	\$ 31	\$ 47	\$ 68	\$ 89	\$ 111	\$ 131	\$ 304
Double With	Matching Welt	MLM9S	\$ 3700	Seat	\$ 89	\$ 178	\$ 268	\$ 387	\$ 506	\$ 625	\$ 744	\$ 1719
LH Half				Bolster	\$ 32	\$ 65	\$ 98	\$ 141	\$ 184	\$ 228	\$ 271	\$ 627
Bolster	Contrast Welt	MLM9	\$ 3895	Seat	\$ 79	\$ 157	\$ 236	\$ 342	\$ 446	\$ 552	\$ 657	\$ 1517
				Seat Welt	\$ 20	\$ 41	\$ 62	\$ 89	\$ 116	\$ 143	\$ 171	\$ 394
				Bolster	\$ 20	\$ 41	\$ 62	\$ 89	\$ 116	\$ 143	\$ 171	\$ 394
				Bolster Welt	\$ 16	\$ 31	\$ 47	\$ 68	\$ 89	\$ 111	\$ 131	\$ 304
Double With	Matching Welt	MLM10S	\$ 3700	Seat	\$ 89	\$ 178	\$ 268	\$ 387	\$ 506	\$ 625	\$ 744	\$ 1719
RH Half				Bolster	\$ 32	\$ 65	\$ 98	\$ 141	\$ 184	\$ 228	\$ 271	\$ 627
Bolster	Contrast Welt	MLM10	\$ 3895	Seat	\$ 79	\$ 157	\$ 236	\$ 342	\$ 446	\$ 552	\$ 657	\$ 1517
				Seat Welt	\$ 20	\$ 41	\$ 62	\$ 89	\$ 116	\$ 143	\$ 171	\$ 394
				Bolster	\$ 20	\$ 41	\$ 62	\$ 89	\$ 116	\$ 143	\$ 171	\$ 394
				Bolster Welt	\$ 16	\$ 31	\$ 47	\$ 68	\$ 89	\$ 111	\$ 131	\$ 304
Double With	Matching Welt	MLM11S	\$ 4177	Seat	\$ 89	\$ 178	\$ 268	\$ 387	\$ 506	\$ 625	\$ 744	\$ 1719
LH				Bolster	\$ 60	\$ 121	\$ 183	\$ 263	\$ 345	\$ 427	\$ 507	\$ 1173
L-Bolster	Contrast Welt	MLM11	\$ 4399	Seat	\$ 79	\$ 157	\$ 236	\$ 342	\$ 446	\$ 552	\$ 657	\$ 1517
				Seat Welt	\$ 20	\$ 41	\$ 62	\$ 89	\$ 116	\$ 143	\$ 171	\$ 394
				Bolster	\$ 52	\$ 104	\$ 156	\$ 225	\$ 295	\$ 363	\$ 433	\$ 1001
				Bolster Welt	\$ 16	\$ 31	\$ 47	\$ 68	\$ 89	\$ 111	\$ 131	\$ 304
Double With	Matching Welt	MLM13S	\$ 4177	Seat	\$ 89	\$ 178	\$ 268	\$ 387	\$ 506	\$ 625	\$ 744	\$ 1719
RH				Bolster	\$ 60	\$ 121	\$ 183	\$ 263	\$ 345	\$ 427	\$ 507	\$ 1173
L-Bolster	Contrast Welt	MLM13	\$ 4399	Seat	\$ 79	\$ 157	\$ 236	\$ 342	\$ 446	\$ 552	\$ 657	\$ 1517
				Seat Welt	\$ 20	\$ 41	\$ 62	\$ 89	\$ 116	\$ 143	\$ 171	\$ 394
				Bolster	\$ 52	\$ 104	\$ 156	\$ 225	\$ 295	\$ 363	\$ 433	\$ 1001
				Bolster Welt	\$ 16	\$ 31	\$ 47	\$ 68	\$ 89	\$ 111	\$ 131	\$ 304

Example of upcharges: Model MLM13 with Grade 5 Seat, Grade 2 Seat Welt, Grade 1 Bolster, and Grade 2 Bolster Welt = \$4399 + \$342 + \$20 + \$0 + \$16 = **\$4777 Total**

Continued on next page ►

<p>How to specify — Select the Model Number from above.</p>	<p>1st Option FSC Certified Wood: FSC Select for FSC certified wood</p>	<p>2nd Option Select the Power Cutout Option (if applicable): N No Power Cutout L Left Side (\$39 extra) R Right Side (\$39 extra) B Both Sides (\$78 extra) FL Front Left (\$39 extra) FR Front Right (\$39 extra) FB Front Both (\$78 extra)</p>	<p>3rd Option Select the Seat Upholstery: See page 228 for selections and color codes. See Seating Price List for COM Guidelines.</p>	<p>4th Option Select the Seat Welt Cord Upholstery (if applicable): See page 228 for selections and color codes.</p>	<p>5th Option: Select the Bolster Upholstery (if applicable): See page 228 for selections and color codes.</p>
<p>MLM . F S C </p>					

Examples: MMLM9S.FSC.UR10.SCAMBLZ24 MLM11.FSC.B.SHBFBVCV90.PURL08.SHBFBVCV80.PURL08

Model Number		Overall			Seat			Backrest				Ship Weight	Cubes			
		COM Yardage	COL Sq. Feet	Height	Width	Depth	Height	Width	Depth	Ran Angle	Height			Width	Lumbar Height	Backrest/Seat Angle
MLM3S	Seat	7.5	—	17¼"	58"	29"	17¼"	58"	29"	—					125	41.8
MLM3	Seat	6.25	—	17¼"	58"	29"	17¼"	58"	29"	—					125	41.8
	Welt	1.25	—													
MLM4S	Seat	7.5	—	28¾"	58"	29"	17¼"	58"	20"	—	11½"	58"	8½"	101°	135	41.8
	Bolster	3.5	—													
MLM4	Seat	6.25	—	28¾"	58"	29"	17¼"	58"	20"	—	11½"	58"	8½"	101°	135	41.8
	Seat Welt	1.25	—													
	Bolster	2.5	—													
	Bolster Welt	1.0	—													
MLM9S	Seat	7.5	—	28¾"	58"	29"	17¼"	58"	20"	—	11½"	29"	8½"	101°	130	41.8
	Bolster	3.5	—													
MLM9	Seat	6.25	—	28¾"	58"	29"	17¼"	58"	20"	—	11½"	29"	8½"	101°	130	41.8
	Seat Welt	1.25	—													
	Bolster	2.5	—													
	Bolster Welt	1.0	—													
MLM10S	Seat	7.5	—	28¾"	58"	29"	17¼"	58"	20"	—	11½"	29"	8½"	101°	130	41.8
	Bolster	3.5	—													
MLM10	Seat	6.25	—	28¾"	58"	29"	17¼"	58"	20"	—	11½"	29"	8½"	101°	130	41.8
	Seat Welt	1.25	—													
	Bolster	2.5	—													
	Bolster Welt	1.0	—													
MLM11S	Seat	7.5	—	28¾"	58"	29"	17¼"	49"	20"	—	11½"	48½"	8½"	101°	140	41.8
	Bolster	4.0	—													
MLM11	Seat	6.25	—	28¾"	58"	29"	17¼"	49"	20"	—	11½"	48½"	8½"	101°	140	41.8
	Seat Welt	1.25	—													
	Bolster	3.0	—													
	Bolster Welt	1.0	—													
MLM13S	Seat	7.5	—	28¾"	58"	29"	17¼"	49"	20"	—	11½"	48½"	8½"	101°	140	41.8
	Bolster	4.0	—													
MLM13	Seat	6.25	—	28¾"	58"	29"	17¼"	49"	20"	—	11½"	48½"	8½"	101°	140	41.8
	Seat Welt	1.25	—													
	Bolster	3.0	—													
	Bolster Welt	1.0	—													

*COM Yardage is listed for total yardage required for a model, with applicable yardage for individual components listed below each total: Seat, Seat Welt, Bolster, and Bolster Welt. If the same upholstery material is used for all components, use just the bold total yardage that aligns with the model number.

◀ Continued from previous page

6th Option:

Select the Bolster Welt Cord Upholstery (if applicable):

See page 228 for selections and color codes.

(See page 319 for COM pricing on Grades 9-22)

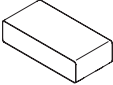
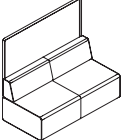
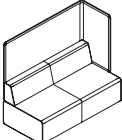
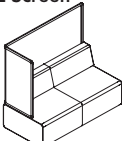
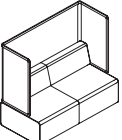
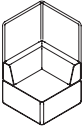
Style	Description	Model Number <i>Add options below</i>	Base Price	Upholstery Upcharges	Upcharge							
					2	3	4	5	6	7	8	L1
Double Seats and Corner Seats												
Double	Matching Welt	MLM44S	\$ 2918	Seat	\$ 104	\$ 209	\$ 312	\$ 451	\$ 590	\$ 728	\$ 866	\$ 1940
End Cap	Contrast Welt	MLM44	\$ 3063	Seat	\$ 103	\$ 204	\$ 307	\$ 443	\$ 579	\$ 714	\$ 851	\$ 1906
				Welt	\$ 14	\$ 28	\$ 41	\$ 58	\$ 77	\$ 94	\$ 112	\$ 250
Double With Straight Screen	Matching Welt	MLM5S	\$ 4861	Seat	\$ 89	\$ 178	\$ 268	\$ 387	\$ 506	\$ 625	\$ 744	\$ 1719
	Contrast Welt	MLM5	\$ 5116	Bolster	\$ 46	\$ 93	\$ 140	\$ 202	\$ 264	\$ 327	\$ 390	\$ 901
				Seat	\$ 79	\$ 157	\$ 236	\$ 342	\$ 446	\$ 552	\$ 657	\$ 1517
				Seat Welt	\$ 20	\$ 41	\$ 62	\$ 89	\$ 116	\$ 143	\$ 171	\$ 394
				Bolster	\$ 36	\$ 72	\$ 108	\$ 157	\$ 205	\$ 253	\$ 302	\$ 698
				Bolster Welt	\$ 16	\$ 31	\$ 47	\$ 68	\$ 89	\$ 111	\$ 131	\$ 304
Double With LH L-Screen	Matching Welt	MLM6S	\$ 5441	Seat	\$ 89	\$ 178	\$ 268	\$ 387	\$ 506	\$ 625	\$ 744	\$ 1719
	Contrast Welt	MLM6	\$ 5726	Bolster	\$ 46	\$ 93	\$ 140	\$ 202	\$ 264	\$ 327	\$ 390	\$ 901
				Seat	\$ 79	\$ 157	\$ 236	\$ 342	\$ 446	\$ 552	\$ 657	\$ 1517
				Seat Welt	\$ 20	\$ 41	\$ 62	\$ 89	\$ 116	\$ 143	\$ 171	\$ 394
				Bolster	\$ 36	\$ 72	\$ 108	\$ 157	\$ 205	\$ 253	\$ 302	\$ 698
				Bolster Welt	\$ 16	\$ 31	\$ 47	\$ 68	\$ 89	\$ 111	\$ 131	\$ 304
Double With RH L-Screen	Matching Welt	MLM7S	\$ 5441	Seat	\$ 89	\$ 178	\$ 268	\$ 387	\$ 506	\$ 625	\$ 744	\$ 1719
	Contrast Welt	MLM7	\$ 5726	Bolster	\$ 46	\$ 93	\$ 140	\$ 202	\$ 264	\$ 327	\$ 390	\$ 901
				Seat	\$ 79	\$ 157	\$ 236	\$ 342	\$ 446	\$ 552	\$ 657	\$ 1517
				Seat Welt	\$ 20	\$ 41	\$ 62	\$ 89	\$ 116	\$ 143	\$ 171	\$ 394
				Bolster	\$ 36	\$ 72	\$ 108	\$ 157	\$ 205	\$ 253	\$ 302	\$ 698
				Bolster Welt	\$ 16	\$ 31	\$ 47	\$ 68	\$ 89	\$ 111	\$ 131	\$ 304
Double With U-Screen	Matching Welt	MLM8S	\$ 5732	Seat	\$ 89	\$ 178	\$ 268	\$ 387	\$ 506	\$ 625	\$ 744	\$ 1719
	Contrast Welt	MLM8	\$ 6034	Bolster	\$ 46	\$ 93	\$ 140	\$ 202	\$ 264	\$ 327	\$ 390	\$ 901
				Seat	\$ 79	\$ 157	\$ 236	\$ 342	\$ 446	\$ 552	\$ 657	\$ 1517
				Seat Welt	\$ 20	\$ 41	\$ 62	\$ 89	\$ 116	\$ 143	\$ 171	\$ 394
				Bolster	\$ 36	\$ 72	\$ 108	\$ 157	\$ 205	\$ 253	\$ 302	\$ 698
				Bolster Welt	\$ 16	\$ 31	\$ 47	\$ 68	\$ 89	\$ 111	\$ 131	\$ 304
Square Corner With Screen	Matching Welt	MLM35S	\$ 4262	Seat	\$ 51	\$ 102	\$ 153	\$ 222	\$ 289	\$ 357	\$ 426	\$ 983
	Contrast Welt	MLM35	\$ 4476	Bolster	\$ 46	\$ 93	\$ 140	\$ 202	\$ 264	\$ 327	\$ 390	\$ 901
				Seat	\$ 44	\$ 88	\$ 132	\$ 191	\$ 250	\$ 309	\$ 368	\$ 850
				Seat Welt	\$ 12	\$ 26	\$ 38	\$ 55	\$ 71	\$ 88	\$ 105	\$ 242
				Bolster	\$ 36	\$ 72	\$ 108	\$ 157	\$ 205	\$ 253	\$ 302	\$ 698
				Bolster Welt	\$ 16	\$ 31	\$ 47	\$ 68	\$ 89	\$ 111	\$ 131	\$ 304

Example of upcharges: Model MLM8 with Grade 5 Seat, Grade 2 Seat Welt, Grade 1 Bolster, and Grade 2 Bolster Welt = \$6034 + \$342 + \$20 + \$0 + \$16 = **\$6412 Total**

Continued on next page ▶

<p>How to specify — Select the Model Number from above.</p>	<p>1st Option FSC Certified Wood: FSC Select for FSC certified wood</p>	<p>2nd Option Select the Power Cutout Option (if applicable. End Cap only has N or Y): N No Power Cutout Y* End Cap Power (\$78 extra) L Left Side (\$39 extra) R Right Side (\$39 extra) B Both Sides (\$78 extra) FL Front Left (\$39 extra) FR Front Right (\$39 extra) FB Front Both (\$78 extra)</p>	<p>3rd Option Select the Seat Upholstery: See page 228 for selections and color codes. See Seating Price List for COM Guidelines.</p>	<p>4th Option Select the Seat Welt Cord Upholstery (if applicable): See page 228 for selections and color codes.</p>	<p>5th Option: Select the Bolster Upholstery (if applicable): See page 228 for selections and color codes.</p>
MLM	F S C				

Examples: MLM44S.FSC.Y.SCAMBLZ24 MLM6.FSC.FB.SHBFBCV90.PURL08.SHBFBCV80.PURL08.MDD

Model Number		Overall			Seat			Backrest			Ship Weight	Cubes				
		COM Yardage	COL Sp. Feet	Height	Width	Depth	Height	Width	Depth	Pan Angle			Height	Width	Lumbar Height	Backrest/Seat Angle
MLM4S	Seat	8.0	—	17¼"	29"	58"	17¼"	29"	58"	—					77	19.8
MLM4	Seat	6.25	—	17¼"	29"	58"	17¼"	29"	58"	—					77	19.8
	Welt	1.75	—													
MLM5S	Seat	7.5	—	53¾"	58"	29"	17¼"	58"	20"	—	11½"	58"	8½"	101°	157	43
	Bolster	3.5	—													
MLM5	Seat	6.25	—	53¾"	58"	29"	17¼"	58"	20"	—	11½"	58"	8½"	101°	157	43
	Seat Welt	1.25	—													
	Bolster	2.5	—													
	Bolster Welt	1.0	—													
MLM6S	Seat	7.5	—	53¾"	58"	29"	17¼"	57¼"	20"	—	11½"	57¼"	8½"	101°	165	44.3
	Bolster	3.5	—													
MLM6	Seat	6.25	—	53¾"	58"	29"	17¼"	57¼"	20"	—	11½"	57¼"	8½"	101°	165	44.3
	Seat Welt	1.25	—													
	Bolster	2.5	—													
	Bolster Welt	1.0	—													
MLM7S	Seat	7.5	—	53¾"	58"	29"	17¼"	57¼"	20"	—	11½"	57¼"	8½"	101°	165	44.3
	Bolster	3.5	—													
MLM7	Seat	6.25	—	53¾"	58"	29"	17¼"	57¼"	20"	—	11½"	57¼"	8½"	101°	165	44.3
	Seat Welt	1.25	—													
	Bolster	2.5	—													
	Bolster Welt	1.0	—													
MLM8S	Seat	7.5	—	53¾"	58"	29"	17¼"	56½"	20"	—	11½"	56½"	8½"	101°	175	44.3
	Bolster	3.5	—													
MLM8	Seat	6.25	—	53¾"	58"	29"	17¼"	56½"	20"	—	11½"	56½"	8½"	101°	175	44.3
	Seat Welt	1.25	—													
	Bolster	2.5	—													
	Bolster Welt	1.0	—													
MLM35S	Seat	3.75	—	53¾"	29"	29"	17¼"	20"	20"	—	11½"	20"	8½"	101°	95	30.8
	Bolster	3.0	—													
MLM35	Seat	2.5	—	53¾"	29"	29"	17¼"	20"	20"	—	11½"	20"	8½"	101°	95	30.8
	Seat Welt	1.25	—													
	Bolster	2.0	—													
	Bolster Welt	1.0	—													

*COM Yardage is listed for total yardage required for a model, with applicable yardage for individual components listed below each total: Seat, Seat Welt, Bolster, and Bolster Welt. If the same upholstery material is used for all components, use just the bold total yardage that aligns with the model number.

◀ Continued from previous page

<p>6th Option: Select the Bolster Welt Cord Upholstery (if applicable): See page 228 for selections and color codes.</p>	<p>7th Option: Select the Screen Color (if applicable): LGT Light Gray MDD Medium Gray DRK Dark Gray</p>
--	---

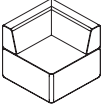
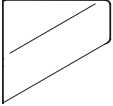
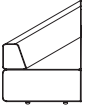
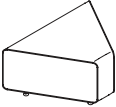
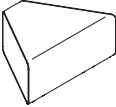
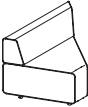
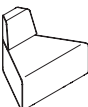
Style	Description	Model Number <i>Add options below</i>	Base Price	Upholstery Upcharges	Upcharge							
					2	3	4	5	6	7	8	L1
Corner Seats (No Power)												
	Matching Welt	MLM27S	\$ 2790	Seat	\$ 51	\$ 102	\$ 153	\$ 222	\$ 289	\$ 357	\$ 426	\$ 983
	Contrast Welt	MLM27	\$ 2936	Bolster	\$ 46	\$ 93	\$ 140	\$ 202	\$ 264	\$ 327	\$ 390	\$ 901
				Seat	\$ 44	\$ 88	\$ 132	\$ 191	\$ 250	\$ 309	\$ 368	\$ 850
				Seat Welt	\$ 12	\$ 26	\$ 38	\$ 55	\$ 71	\$ 88	\$ 105	\$ 242
				Bolster	\$ 36	\$ 72	\$ 108	\$ 157	\$ 205	\$ 253	\$ 302	\$ 698
Bolster Welt	\$ 16	\$ 31	\$ 47	\$ 68	\$ 89	\$ 111	\$ 131	\$ 304				
	Matching Welt	MLM41S	\$ 1724	Seat	\$ 55	\$ 109	\$ 163	\$ 235	\$ 309	\$ 380	\$ 452	\$ 1012
	Contrast Welt	MLM41	\$ 1809	Seat	\$ 47	\$ 94	\$ 141	\$ 203	\$ 266	\$ 329	\$ 391	\$ 875
				Seat Welt	\$ 14	\$ 28	\$ 41	\$ 58	\$ 77	\$ 94	\$ 112	\$ 250
*Ganging Kit Included												
	Matching Welt	MLM38S	\$ 2595	Seat	\$ 55	\$ 109	\$ 163	\$ 235	\$ 309	\$ 380	\$ 452	\$ 1012
	Contrast Welt	MLM38	\$ 2723	Bolster	\$ 32	\$ 65	\$ 95	\$ 137	\$ 180	\$ 222	\$ 263	\$ 590
				Seat	\$ 47	\$ 94	\$ 141	\$ 203	\$ 266	\$ 329	\$ 391	\$ 875
				Seat Welt	\$ 14	\$ 28	\$ 41	\$ 58	\$ 77	\$ 94	\$ 112	\$ 250
				Bolster	\$ 22	\$ 44	\$ 66	\$ 94	\$ 124	\$ 153	\$ 181	\$ 406
Bolster Welt	\$ 14	\$ 28	\$ 41	\$ 58	\$ 77	\$ 94	\$ 112	\$ 250				
*Ganging Kit Included												
	Matching Welt	MLM42S	\$ 1852	Seat	\$ 57	\$ 115	\$ 173	\$ 249	\$ 325	\$ 401	\$ 477	\$ 1069
	Contrast Welt	MLM42	\$ 1944	Seat	\$ 51	\$ 101	\$ 151	\$ 218	\$ 285	\$ 351	\$ 419	\$ 938
				Seat Welt	\$ 14	\$ 28	\$ 41	\$ 58	\$ 77	\$ 94	\$ 112	\$ 250
*Ganging Kit Included												
	Matching Welt	MLM43S	\$ 1852	Seat	\$ 57	\$ 115	\$ 173	\$ 249	\$ 325	\$ 401	\$ 477	\$ 1069
	Contrast Welt	MLM43	\$ 1944	Seat	\$ 51	\$ 101	\$ 151	\$ 218	\$ 285	\$ 351	\$ 419	\$ 938
				Seat Welt	\$ 14	\$ 28	\$ 41	\$ 58	\$ 77	\$ 94	\$ 112	\$ 250
*Ganging Kit Included												
	Matching Welt	MLM39S	\$ 2688	Seat	\$ 57	\$ 115	\$ 173	\$ 249	\$ 325	\$ 401	\$ 477	\$ 1069
	Contrast Welt	MLM39	\$ 2825	Bolster	\$ 32	\$ 65	\$ 95	\$ 137	\$ 180	\$ 222	\$ 263	\$ 590
				Seat	\$ 51	\$ 101	\$ 151	\$ 218	\$ 285	\$ 351	\$ 419	\$ 938
				Seat Welt	\$ 14	\$ 28	\$ 41	\$ 58	\$ 77	\$ 94	\$ 112	\$ 250
				Bolster	\$ 22	\$ 44	\$ 66	\$ 94	\$ 124	\$ 153	\$ 181	\$ 406
Bolster Welt	\$ 14	\$ 28	\$ 41	\$ 58	\$ 77	\$ 94	\$ 112	\$ 250				
*Ganging Kit Included												
	Matching Welt	MLM40S	\$ 2512	Seat	\$ 57	\$ 115	\$ 173	\$ 249	\$ 325	\$ 401	\$ 477	\$ 1069
	Contrast Welt	MLM40	\$ 2637	Bolster	\$ 33	\$ 67	\$ 100	\$ 143	\$ 189	\$ 232	\$ 276	\$ 619
				Seat	\$ 51	\$ 101	\$ 151	\$ 218	\$ 285	\$ 351	\$ 419	\$ 938
				Seat Welt	\$ 14	\$ 28	\$ 41	\$ 58	\$ 77	\$ 94	\$ 112	\$ 250
				Bolster	\$ 23	\$ 47	\$ 70	\$ 102	\$ 133	\$ 164	\$ 196	\$ 438
Bolster Welt	\$ 14	\$ 28	\$ 41	\$ 58	\$ 77	\$ 94	\$ 112	\$ 250				
*Ganging Kit Included												

Example of upcharges: Model MLM39 with Grade 5 Seat, Grade 2 Seat Welt, Grade 1 Bolster, and Grade 2 Bolster Welt = \$2825 + \$218 + \$14 + \$0 + \$14 = **\$3071 Total**

<p>How to specify — Select the Model Number from above.</p>	<p><i>1st Option</i> FSC Certified Wood: FSC Select for FSC certified wood</p>	<p><i>2nd Option</i> Select the Seat Upholstery: See page 228 for selections and color codes. See Seating Price List for COM Guidelines.</p>	<p><i>3rd Option</i> Select the Seat Welt Cord Upholstery (if applicable): See page 228 for selections and color codes.</p>	<p><i>4th Option:</i> Select the Bolster Upholstery (if applicable): See page 228 for selections and color codes.</p>	<p><i>5th Option:</i> Select the Bolster Welt Cord Upholstery (if applicable): See page 228 for selections and color codes.</p>
<p>MLM . F S C </p>					

Examples: MLM42S.FSC.UR10 MLM39.FSC.SHBFBCV90.PURL08.SHBFBCV80.PURL08

Model Number		Overall			Seat			Backrest				Ship Weight	Cubes			
		COM Yardage	COL Sq. Feet	Height	Width	Depth	Height	Width	Depth	Ran Angle	Height			Width	Lumbar Height	Backrest/Seat Angle
MLM27S	Seat	3.75	—	28 1/4"	29"	29"	17 1/4"	20"	20"	—	11 1/2"	20"	8 1/2"	101°	90	26.3
	Bolster	3.0	—													
MLM27	Seat	2.5	—	28 1/4"	29"	29"	17 1/4"	20"	20"	—	11 1/2"	20"	8 1/2"	101°	90	26.3
	Seat Welt	1.25	—													
	Bolster	2.0	—													
	Bolster Welt	1.0	—													
MLM41S	Seat	4.0	—	17 1/4"	41"	20"	17 1/4"	41"	20"	—					34	10
MLM41	Seat	2.75	—	17 1/4"	41"	20"	17 1/4"	41"	20"	—					34	10
	Seat Welt	1.25	—													
MLM38S	Seat	4.0	—	28 1/4"	41"	20"	17 1/4"	20"	15"	—	11 1/2"	20"	8 1/2"	101°	50	17.8
	Bolster	2.5	—													
MLM38	Seat	2.75	—	28 1/4"	41"	20"	17 1/4"	20"	15"	—	11 1/2"	20"	8 1/2"	101°	50	17.8
	Seat Welt	1.25	—													
	Bolster	1.5	—													
	Bolster Welt	1.0	—													
MLM42S	Seat	4.25	—	17 1/4"	36"	25"	17 1/4"	36"	25"	—					38	11.4
MLM42	Seat	3.0	—	17 1/4"	36"	25"	17 1/4"	36"	25"	—					38	11.4
	Seat Welt	1.25	—													
MLM43S	Seat	4.25	—	17 1/4"	36"	25"	17 1/4"	36"	25"	—					38	11.4
MLM43	Seat	3.0	—	17 1/4"	36"	25"	17 1/4"	36"	25"	—					38	11.4
	Seat Welt	1.25	—													
MLM39S	Seat	4.25	—	28 1/4"	36"	25"	17 1/4"	18"	20"	—	11 1/2"	30"	8 1/2"	101°	54	19.4
	Bolster	2.5	—													
MLM39	Seat	3.0	—	28 1/4"	36"	25"	17 1/4"	18"	20"	—	11 1/2"	30"	8 1/2"	101°	54	19.4
	Seat Welt	1.25	—													
	Bolster	1.5	—													
	Bolster Welt	1.0	—													
MLM40S	Seat	4.25	—	28 1/4"	36"	25"	17 1/4"	18"	20"	—	11 1/2"	7"	8 1/2"	101°	48	19.4
	Bolster	2.0	—													
MLM40	Seat	3.0	—	28 1/4"	36"	25"	17 1/4"	18"	20"	—	11 1/2"	7"	8 1/2"	101°	48	19.4
	Seat Welt	1.25	—													
	Bolster	1.0	—													
	Bolster Welt	1.0	—													

*COM Yardage is listed for total yardage required for a model, with applicable yardage for individual components listed below each total: Seat, Seat Welt, Bolster, and Bolster Welt. If the same upholstery material is used for all components, use just the bold total yardage that aligns with the model number.

Social Collaborative — Seating Collections

Recharge™

GSA SIN 33721

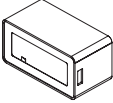
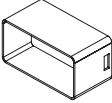
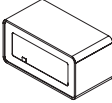

	Description	Model Number Power Location	Ship Weight	Cubes	L1	Laminate L2	L3
  	Straight Connector Table 14½"W x 28½"D x 17"H	Power Cutout Right	MLMR15	28	6.8	\$ 2719	\$ 2836 \$ 2913
	Power Cutout Left	MLML15	28	6.8	\$ 2719	\$ 2836 \$ 2913	
	No Power Cutout	MLM15N	28	6.8	\$ 2719	\$ 2836 \$ 2913	

MLMR15

MLML15

MLM15N

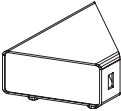
*Ganging Kit Included

 	120° x 2 Connector Table 35¾"W x 24¾"D x 17"H	One Power Cutout	MLM16	30	12.3	\$ 3247	\$ 3387 \$ 3478
	No Power Cutout	MLM16N	30	12.3	\$ 3247	\$ 3387 \$ 3478	

MLM16

MLM16N

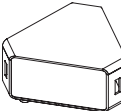
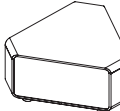
 	120° x 3 Connector Table 35¾"W x 31"D x 17"H	Three Power Cutouts	MLM17	35	14.1	\$ 4830	\$ 5036 \$ 5173
	No Power Cutouts	MLM17N	35	14.1	\$ 4830	\$ 5036 \$ 5173	

MLM17

MLM17N

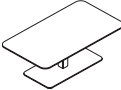
	Coffee Table 48"L x 27"W x 17"H	No Power	MLM19	145	24.9	\$ 1821	\$ 1887 \$ 1951
--	---------------------------------	----------	-------	-----	------	---------	-----------------

	Work Table 48"L x 27"W x 28"H	No Power	MLM22	150	29.0	\$ 1988	\$ 2054 \$ 2118
---	-------------------------------	----------	-------	-----	------	---------	-----------------

	Corner Table 29"L x 29"W x 17"H	No Power	MLM26	73	14.7	\$ 1744	\$ 1806 \$ 1868
---	---------------------------------	----------	-------	----	------	---------	-----------------

	Laptop Table 22"L x 17"W x 28"H	No Power	MLM18	37	11.8	\$ 902	\$ 935 \$ 967
---	---------------------------------	----------	-------	----	------	--------	---------------

<p>How to specify — Select the Model Number from above.</p> <p>MLM .</p>	<p>1st Option: Select the Laminate Color (if applicable): See page 227 for selections and color codes.</p> <p>Connector Tables limited to: LDW1 Designer White LM16 Flint</p> <p> .</p>	<p>2nd Option: Select the Laminate Edge Color (if applicable): See page 227 for selections and color codes. Connector Tables do not require an edge color.</p> <p> .</p>	<p>3rd Option: Select the Table Base Paint Color (if applicable): See page 227 for selections and color codes.</p> <p> .</p>
---	---	--	--

Examples: MLMR15.LDW1 MLM22.LDW1.DW.PR8 MLM18.LM16.E9.P7A

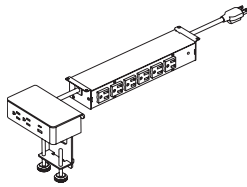

AABPWRMOD.AC.S

Description	Model Number	Ship Weight	Cubes	List Price
Power Module — Above/Below Worksurface				
8¼" W x 16"D x 4½"H	AABPWRMOD S			\$ 1234

- Desktop unit includes 2 receptacles, 1 USB-A, & 1 USB-C (AC)
- Under worksurface unit includes 6 receptacles.
- Power cord choices include a 6' Straight cord (S) or Coiled cord (Q).
- Desktop unit available in White (DWT) or Gray (DGY).
- *Example: AABPWRMOD.AC.S.DWT*

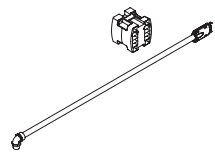

Electrical 4-Wire Infeeds (black only)				
72" Sealtight Cable with H-Connector	S922P4S72K	2.1	0.7	\$ 309
New York Code version with H-Connector	S922P4NYK	4.5	0.7	\$ 454

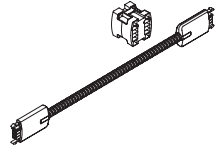

Electrical 4-Wire Jumpers				
42" Jumper with H-Connector	MLM42J	1.3	0.4	\$ 143
72" Jumper with H-Connector	MLM72J	2	0.8	\$ 193

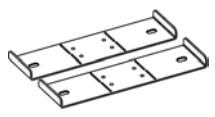

Ganging Kit				
Pack of 2	MLMGK	3.0	0.1	\$ 11

<p>How to specify — Select the Model Number from above.</p>	<p>1st Option: Ports (Final port option if applicable): AC USB-A+C QA Wireless Charging with 1 USB-A port (+\$125)</p>	<p>2nd Option: Cord Type (Power Module cord type if applicable): S Straight Cord B Braided Chevron Fog & Storm Cord (+\$91) I Interlink Cord (+\$55) H Hardwire Cord (+\$106) Q Coiled Cord</p>	<p>3rd Option: Color Option (if applicable): SNW Snow STRM Storm BLK Black DWT White DGY Gray</p>
--	--	--	--

Example: AABPWRMOD.AC.S.SBW MLM72J

S Shippable by small-package carrier.

BASE PAINT FINISHES

GRADE P1

Charblack	CBK
Textured Designer White	PK7
Textured Brownstone	P7J
Textured Flint	P7A
Textured Titanium	P8V
Textured Loft	P7L
Textured Muslin	P7M
Textured Pebble	P8Y
Textured Salt	P8Z

GRADE P2

Night Bronze	P8B
Pyrite	PJE
Solar Black	P8X
Textured Silver	PR8

GRADE P3

Atom	P8S
Blossom***	P8K
Bullseye	PJF
Cabernet***	P7T
Conifer***	P8H
Ember	P8P
Ion	P8N
Iris	P8J
Krypton	P8F
Regatta	P8M
Succulent***	P8A

LAMINATES

GRADE L1

SOLID COLORS

Black	P
Brownstone	LM13
Bungalow	LM12
Designer White	LDW1
Flint	LM16
Fossil Shale	LEH1
Loft	LM11
Muslin	LM15
Titanium	LTI1

ABSTRACT

Ash	LT3B
Handspun Pearl	LAHP
Handspun Dove	LAHD
Handspun Slate	LAHS
Handspun Chestnut	LAHC
Silver Mesh	LT8D

WOODGRAIN

Belair	LWBA
Bourbon Cherry	H
Field Elm	LWFE
Florence Walnut	LFW1
Kingswood Walnut	LK11
Natural Maple	LWD
NeoWalnut	LNU1
Pinnacle	PINC
Shaker Cherry	LW7C

GRADE L2

Beigewood	LWBE
Fawn Cypress	LFC1
Lowell Ash	LLA1
Mangalore Mango	LMM1
Natural Recon	LNR1
Phantom Charcoal	LPC1
Phantom Ecu	LPE1
Portico Teak	LPT1
Skyline Walnut	LSW1
Veranda Teak	LVT1

GRADE L3

Natural Walnut	LWNW
----------------------	------

LAMINATE EDGE COLORS

Beigewood	DE
Belair	BA
Black	E4
Bourbon Cherry	H
Brownstone	EY
Bungalow	EX
Designer White	DW
Fawn Cypress	FC
Field Elm	FE
Flint	E9
Florence Walnut	FW
Fossil	EH
Kingswood Walnut	KI
Loft	EV
Lowell Ash	DL
Mangalore Mango	MM
Muslin	EU
Natural Maple	DD
Natural Recon	NR
Natural Walnut	DN
NeoWalnut	NU
Parchment	EN
Phantom Charcoal	PC
Phantom Ecu	PE
Pinnacle	PI
Platinum Metallic	EP
Portico Teak	DP
Shaker Cherry	DF
Skyline Walnut	SW
Titanium	TI
Veranda Teak	VT

VENEER

GRADE 1

Clear	RE800
Smoked Onyx	RE697
Nutmeg Walnut	RE629

NOTE: Refer to individual product pages for upcharges.

FSC Certified Wood at Allsteel

See page 459 for more information.

Rise Standard Upholstery Selections by Model/Series.

		Rise Seat	Rise Side	Rise 2.0 Seat	Rise 2.0 Side	Rise 2.0 Single Upholstery
GRADE 1						
Apex	APX		•		•	
Centurion	CU	•	•	•	•	•
Contourett	UR		•		•	
Dapper	DAPR		•		•	
Ensemble	ENSB	•	•	•	•	•
Hamilton <i>(De-emphasized)</i>	HAML	•	•	•	•	•
Inertia <i>(De-emphasized)</i>	NR	•	•	•	•	•
GRADE 2						
Appoint Seating	PNS	•	•	•	•	•
Blume	BLME	•	•	•	•	•
Clyde	CLYD	•	•	•	•	•
Dotty <i>(De-emphasized)</i>	DOT	•	•	•	•	•
Meld ⚡	SMHMMLD	•	•	•	•	•
Rush	RUSH	•	•	•	•	•
Spin	SPNN		•		•	
Whisper Vinyl	WP	•	•	•	•	•
GRADE 3						
Lateral ⚡	SCFSLAT		•		•	
Moxie	SX	•	•	•	•	•
Purl	PURL	•	•	•	•	•
Quill	QUL	•	•	•	•	•
GRADE 4						
Caper ⚡	SMHMCAP		•		•	
Manner ⚡	SMHMMAN	•	•	•	•	•
Merit ⚡	SMHMMER		•		•	
Messenger ⚡	SMHMGRM	•	•	•	•	•
Metric ⚡	SMHMMET	•	•	•	•	•
Mode ⚡	SMHMMOD	•	•	•	•	•
Multiply ⚡	SMHMMLT		•		•	
Murmur ⚡	SMHMMUR		•		•	
Muse ⚡	SMHMMUS		•		•	
Trundle ⚡	SMHMTRN		•		•	

⚡ Partnership Program — See page 10 for details.

- Available upholstery option



Rise Standard Upholstery Selections by Model/Series.

Rise Seat
 Rise Side
 Rise 2.0 Seat
 Rise 2.0 Side
 Rise 2.0 Single Upholstery

RISE

GRADE 5						
Main Line Flax Ⓢ	SCAMMLF		•		•	
Rove Ⓢ	SMHMROV		•		•	
GRADE 6						
Arris	ARR	•	•	•	•	•
Blazer Ⓢ	SCAMBLZ		•		•	
Chock Ⓢ	SMHMCCK		•		•	
Hedge Ⓢ	SMHMHED		•		•	
Hemp Ⓢ	SCAMHMP		•		•	
Pocket Ⓢ	SMHMPKT		•		•	
Sequence Ⓢ	SMHMSQN		•		•	
Tandem Ⓢ	SMHMTAN	•	•	•	•	•
GRADE 7						
Silk Ⓢ	SCAMSLK		•		•	
GRADE 8						
Apt Ⓢ	SMHMAPT	•	•	•	•	•
Brisa Ⓢ	RS	•	•	•	•	•
GRADE 9						
Ultraleather Pro Ⓢ	SUF554	•	•	•	•	•
Yoredale Ⓢ	SCAMYDL	•	•	•	•	•

Ⓢ Partnership Program — See page 10 for details.

- Available upholstery option

Take collaboration to a new level.

Rise transforms any space into a meeting space. It is tiered and modular upholstered seating that allows a number of people to gather without taking over an entire room.

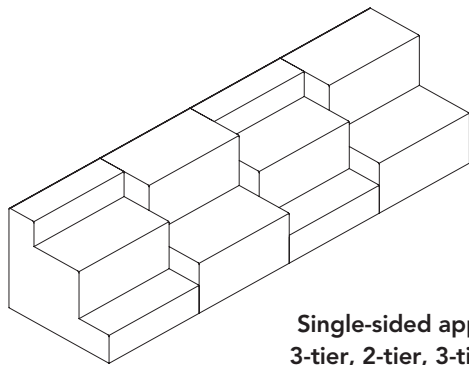

Single-sided application:
3-tier, 2-tier, 3-tier, 2-tier

MODELS AND OPTIONS

Rise is designed as building blocks that can be combined into a variety of configurations. Rise is available as non-powered or power-ready. Rise is not intended for use as stairs.

APPLICATION

Use Rise back-to-back or side-by-side against a wall in atriums, open plan areas, brainstorming/huddle rooms, conference room, cafés, waiting areas, or lounges.

KEY FEATURES

Rise is constructed of fabric covered foam with upholstery-grade FSC plywood core, box joint, and corner block construction.

Rise has glides that are adjustable up to 2".

Ganging brackets with screws are included for connecting multiple units. Two brackets are required to connect two Rise units together. Soft Wall requires a special ganging bracket S922GB if it is not put between two units.

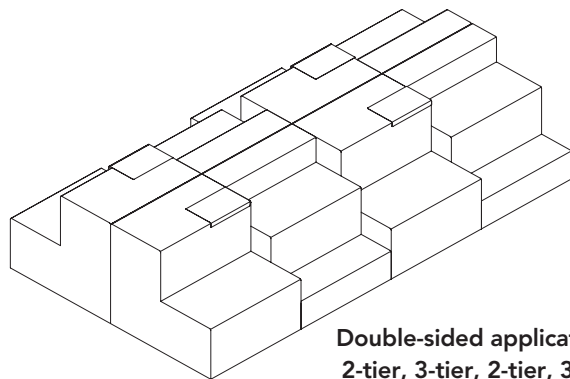

Double-sided application:
2-tier, 3-tier, 2-tier, 3-tier

DIMENSIONS

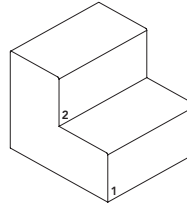

RISE 2-TIER

2-Tier — 34"H x 36"W x 40"D
2-Tier Corner* — 34"H x 40"W x 40"D
Tiers 1 and 2 — 17"H x 20"D

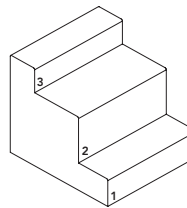

RISE 3-TIER

3-Tier — 34"H x 36"W x 40"D
Tier 1 — 9½"H x 12"D
Tier 2 — 16"H x 18"D
Tier 3 — 8½"H x 10"D

*NOTE: Dimension of unit may not fit through standard door, check installation site prior to ordering.

MATERIALS

The outside cover on Rise is fully upholstered. Rise can be specified in a solid color or two-tone on selected models.

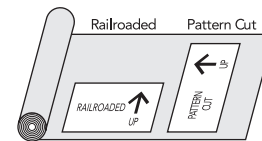

- Due to the dimension of the seat Rise fabric will be pattern cut.
- All upholstery foams are CFC-free.
- All COMs must be approved for upholsterability or applicable fire code compliance prior to order entry. See pages 6-8 for COM ordering instructions.
- **Flammability** code compliance of Allsteel textiles and seating is listed on pages 15-16. COM/COL manufacturers supply certificates of compliance for fabric-only tests such as CAL TB117-2013.

Rise is warranted up to 300 lbs per unit.

See pages 15-16 for upholstery selections.
See pages 17-19 for colors and codes.

CORNER MODELS

Corner Rise models are available in two-tier models and are 40"W x 40"D. Units can be specified in a solid color or two-tone.

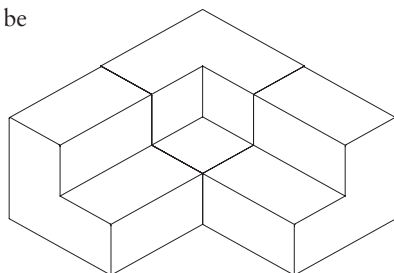

Corner Application:
2-Tier, 2-Tier Inside Corner, 2-Tier

POWER-READY MODELS

Power-ready Rise models have a cut-out on the front right side of the lower tier (see below) that will accept a Rise Power Port (ordered separately). The opening is 6.25"W x 1.94"H.

Rise Power Ports are UL listed and constructed out of anodized aluminum with a painted, steel faceplate and two water-proof outlets and two USB ports. Three power options are available:

- Corded — plugs a single unit into standard outlet
- Hardwire — connects a single unit to power source by a licensed electrician
- 4-Wire used for powering multiple units — requires 4-Wire Infeed Kit. 4-wire Jumper Kit(s) may also be required when powering multiple units from the same infeed. See examples.

It's the customer's responsibility to ensure that installation and use of the electrical system, the number of receptacles used on a given circuit, and connections to the building power supply meets all local and national electrical codes.

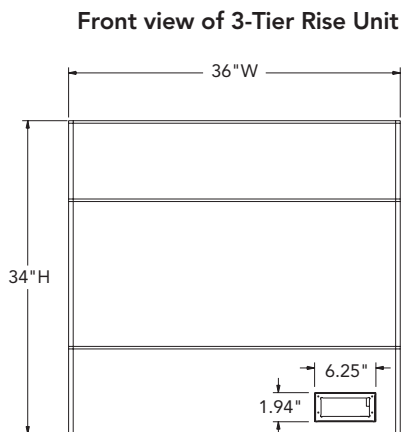

STEPS FOR ORDERING RISE 4-WIRE POWER KITS:

1. Determine the number and location of Powered Rise units in configuration. A maximum of thirteen Powered Rise units can be connected on one Infeed.
 2. Order one 4-Wire Power Port for each Powered Rise unit.
 3. Order one Infeed Kit. Each Infeed Kit includes H-Connector which can power either:
 - Three Rise units.
 - Two Rise units and one Jumper.
 - One Rise unit and two Jumpers.
 - Three Jumpers.
 4. Determine if Jumper with H-Connector Kits are needed for connecting multiple Powered Rise units.
 - A Jumper Kit is required if the distance between the H-Connector on the end of Infeed or Jumper is greater than 72" to the Power Port cut-out in Rise unit.
 - Jumper Kits are available in 36", 72", 108" and 144" lengths.
 - Infeeds and Jumpers can't plug directly into Power Port.
- See examples below. Electrical components listed on page 251.1.

Example 1 — Double-sided Application (Top View)

- 5 – 4-Wire Power Ports
- 1 – Infeed Kit
- 1 – 72" Jumper Kit

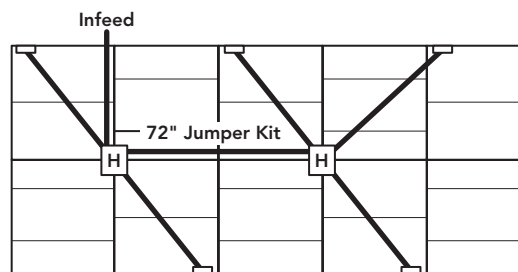

RISE

(See page 320 for COM pricing on Grades 9-22)

RISE

Description	Model Number	Base List Price	Upcharge List Price—Add to Base Price							
			2	3	4	5	6	7	8	
2-Tier Rise										
Non-Powered	S922S2	\$ 3299	\$ 83	\$ 167	\$ 250	\$ 362	\$ 474	\$ 585	\$ 696	
Power-Ready	S922S2P	\$ 3393	\$ 83	\$ 167	\$ 250	\$ 362	\$ 474	\$ 585	\$ 696	
2-Tier Rise Non-Powered Corner										
Inside Corner	S922S2IC	\$ 4504	\$ 102	\$ 204	\$ 307	\$ 444	\$ 580	\$ 717	\$ 854	
Outside Corner	S922S2OC	\$ 4504	\$ 102	\$ 204	\$ 307	\$ 444	\$ 580	\$ 717	\$ 854	
3-Tier Rise										
Non-Powered	S922S3	\$ 3665	\$ 83	\$ 167	\$ 250	\$ 362	\$ 474	\$ 585	\$ 696	
Power-Ready	S922S3P	\$ 3760	\$ 83	\$ 167	\$ 250	\$ 362	\$ 474	\$ 585	\$ 696	

Description	Model Number	Base List Price	Upcharge List Price — Add to Base Price								
			1	2	3	4	5	6	7	8	
Two-tone 2-Tier Rise											
Non-Powered	S922S2T	\$ 3575	Seat Upholstery	\$ 0	\$ 51	\$ 102	\$ 153	\$ 222	\$ 290	\$ 358	\$ 427
Power-Ready	S922S2TP	\$ 3665	Side Upholstery	\$ 0	\$ 31	\$ 63	\$ 94	\$ 137	\$ 178	\$ 221	\$ 262
Two-tone 2-Tier Rise Non-Powered Corner											
Inside Corner	S922S2TIC	\$ 4763	Seat Upholstery	\$ 0	\$ 67	\$ 133	\$ 201	\$ 290	\$ 380	\$ 469	\$ 559
			Side Upholstery	\$ 0	\$ 35	\$ 71	\$ 106	\$ 153	\$ 201	\$ 248	\$ 296
Outside Corner	S922S2TOC	\$ 4763	Seat Upholstery	\$ 0	\$ 67	\$ 133	\$ 201	\$ 290	\$ 380	\$ 469	\$ 559
			Side Upholstery	\$ 0	\$ 35	\$ 71	\$ 106	\$ 153	\$ 201	\$ 248	\$ 296
Two-tone 3-Tier Rise											
Non-Powered	S922S3T	\$ 3941	Seat Upholstery	\$ 0	\$ 51	\$ 102	\$ 153	\$ 222	\$ 290	\$ 358	\$ 427
Power-Ready	S922S3TP	\$ 4033	Side Upholstery	\$ 0	\$ 31	\$ 63	\$ 94	\$ 137	\$ 178	\$ 221	\$ 262

Two-tone Pricing Example:	Model/Options	Base Price/Upcharges
Step 1: Select Model	S922S2T	\$ 3575
Step 2: Select Seat Upholstery (if applicable):	Grade 5 Against the Grain	\$ 222 upcharge
Step 3: Select Side Upholstery	Grade 1 Apex	\$ 0 upcharge
Add Base + applicable Upcharges for Total List Price =		\$ 3797

If sliding glides are needed for any of the above legacy models, please submit a replacement order with Allsteel Customer Support.

- For units ordered before October 1, 2019:
 - Corner Bracket Assembly 3700015600 (Qty 4)
 - Slide Guide 3130100100 (Qty 4)
- For units ordered after October 1, 2019:
 - Slide Glide 3130100100 (Qty 4)

 Shippable by small-package carrier.

<p>How to specify — Select the Model Number from above.</p>	<p><i>1st Option:</i> FSC Certified Wood (if applicable): FSC Select for FSC Certified Wood</p>	<p><i>2nd Option:</i> Select the Upholstery (if applicable): See pages 245-246 for selections.</p>	<p><i>3rd Option:</i> Select the Side Upholstery for Two-tone models (if applicable): See pages 245-246 for selections.</p>
<p>S 9 2 2 . F S C .</p>			

Examples: S922S2.FSC.UR26 S922S3.FSC.UR26
S922S2TP.FSC.ISN041.WP17

RISE DIMENSIONS

GSA SIN 33721

Model Number	Overall			Tier 1			Tier 2			Tier 3			Ship Weight	Cubes	
	COM Yardage	Height	Width	Depth	Height	Width	Depth	Height	Width	Depth	Height	Width			Depth
S922S2	5.5	34"	36"	40"	17"	36"	20"	17"	36"	20"	—	—	—	90	37.5
S922S2P	5.5	34"	36"	40"	17"	36"	20"	17"	36"	20"	—	—	—	90	37.5
S922S2IC	6.5	34"	40"	40"	17"	40"	20"	17"	40"	20"	—	—	—	99	37.5
S922S2OC	6.25*	34"	40"	40"	17"	40"	40"	17"	20"	20"	—	—	—	90	37.5
S922S3	4.75	34"	36"	40"	9½"	36"	12"	16"	36"	18"	8½"	36"	10"	90	37.5
S922S3P	4.75	34"	36"	40"	9½"	36"	12"	16"	36"	18"	8½"	36"	10"	90	37.5
2-Tier															
S922S2T	5.5	34"	36"	40"	17"	36"	20"	17"	36"	20"	—	—	—	90	37.5
S922S2TP	5.5	34"	36"	40"	17"	36"	20"	17"	36"	20"	—	—	—	90	37.5
Seat	3.25														
Side	2.25														
S922S2TIC	6.5*	34"	40"	40"	17"	40"	20"	17"	40"	20"	—	—	—	99	37.5
S922S2TOC	6.25*	34"	40"	40"	17"	40"	40"	17"	20"	20"	—	—	—	90	37.5
3-Tier															
Seat	3.25														
Side	2.0														
S922S3T	5.25	34"	36"	40"	9½"	36"	12"	16"	36"	18"	8½"	36"	10"	90	37.5
S922S3TP	5.25	34"	36"	40"	9½"	36"	12"	16"	36"	18"	8½"	36"	10"	90	37.5

*Two-Tone Inside Corner — Seat 4.25 yds. + Side 2.25 yds. = 6.5 yards. Outside Corner — Seat 4.0 yds. + Side 2.25 yds. = 6.25 yards.



RISE ELECTRICAL COMPONENTS*

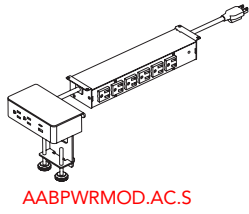

Description	Model Number	PVC Free Model	Ship Weight	Cubes	List Price	PVC Free List Price
Power Module — Above/Below Worksurface 8¼"W x 16"D x 4½"H	AABPWRMOD	S			\$ 1234	N/A

- Desktop unit includes 2 receptacles, 1 USB-A, & 1 USB-C (AC)
- Under worksurface unit includes 6 receptacles.
- Power cord choices include a 6' Straight cord (S) or Coiled cord (Q).
- Desktop unit available in White (DWT) or Gray (DGY).
- Example: AABPWRMOD.AC.S.DWT



Electrical, 4-Wire Infeed Kits (black only)

72" Sealtight Cable with H-Connector	S922P4S72K	S	N/A	2.1	0.7	\$ 309	N/A
144" Sealtight Cable with H-Connector	S922P4S144K	S	N/A	3.7	0.7	\$ 454	N/A

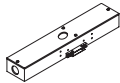

Hardwire, 4-wire Infeed (New York Code)

4-Wire Infeed with H-Connector	S922P4NYK	S	N/A	4.5	0.4	\$ 454	N/A
--------------------------------	-----------	---	-----	-----	-----	--------	-----



Electrical 4-Wire Jumpers

42" Jumper with H-Connector	MLM42J			1.3	0.4	\$ 143	N/A
72" Jumper with H-Connector	MLM72J			2	0.8	\$ 193	N/A

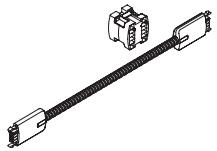

*Applicable for both existing Rise and new power-ready models. Cutout size has changed; old electrical face plates will no longer fit.

RISE

<p>How to specify — Select the Model Number from above.</p>	<p>1st Option: Ports (Final port option if applicable): AC USB-A+C QA Wireless Charging with 1 USB-A port (+\$125)</p>	<p>2nd Option: Cord Type (Power Module cord type if applicable): S Straight Cord B Braided Chevron Fog & Storm Cord (+\$91) I Interlink Cord (+\$55) H Hardwire Cord (+\$106) Q Coiled Cord</p>	<p>3rd Option: Color Option (if applicable): SNW Snow STRM Storm BLK Black DWT White DGY Gray</p>
--	--	--	--

Example: **ABPWRMOD.AC.S.SBW** S922P4S72K.BLK

S Shippable by small-package carrier.

(See page 320 for COM pricing on Grades 9-22)

Description	Model Number	Base List Price	Upcharge List Price—Add to Base Price							
			2	3	4	5	6	7	8	
Single-Tone Chaise										
Non-Powered	S922S2LN	\$ 3563	\$ 126	\$ 252	\$ 378	\$ 547	\$ 714	\$ 882	\$ 1050	
Power-Ready	S922S2LP	\$ 3654	\$ 126	\$ 252	\$ 378	\$ 547	\$ 714	\$ 882	\$ 1050	
Single-Tone Full Ottoman										
Non-Powered	S922SON	\$ 2581	\$ 71	\$ 142	\$ 213	\$ 307	\$ 402	\$ 496	\$ 591	
Power-Ready	S922SOP	\$ 2672	\$ 71	\$ 142	\$ 213	\$ 307	\$ 402	\$ 496	\$ 591	
Full Ottoman Wood Top										
Non-Powered	S922SOWN	\$ 2591	\$ 67	\$ 134	\$ 203	\$ 292	\$ 385	\$ 508	\$ 605	
Power-Ready	S922SOWP	\$ 2682	\$ 67	\$ 134	\$ 203	\$ 292	\$ 385	\$ 508	\$ 605	
Triangle										
Non-Powered	S922SWDN	\$ 2618	\$ 79	\$ 157	\$ 236	\$ 342	\$ 446	\$ 552	\$ 657	
Power-Ready	S922SWDP	\$ 2709	\$ 79	\$ 157	\$ 236	\$ 342	\$ 446	\$ 552	\$ 657	
Triangle Wood Top										
Non-Powered	S922SWDWN	\$ 2628	\$ 61	\$ 122	\$ 159	\$ 238	\$ 318	\$ 400	\$ 481	
Power-Ready	S922SWDWP	\$ 2719	\$ 61	\$ 122	\$ 159	\$ 238	\$ 318	\$ 400	\$ 481	
Half Ottoman										
Non-Powered	S922SHON	\$ 2182	\$ 60	\$ 120	\$ 180	\$ 229	\$ 307	\$ 386	\$ 469	
Rise Half Ottoman Wood Top										
Non-Powered	S922SHOWN	\$ 2187	\$ 55	\$ 110	\$ 165	\$ 210	\$ 281	\$ 354	\$ 430	

Single-tone Pricing Example:	Model/Options	Base Price/Upcharges
Step 1: Select Non-Powered Full Ottoman	S922SON	
Step 2: Select Seat Upholstery	Grade 6 Blazer	\$ 2983 w/upcharge
Add Base + applicable Upcharges for Total List Price =		\$ 2983

<p>How to specify — Select the Model Number from above.</p> <p>S 9 2 2 . F S C . .</p>	<p>1st Option: FSC Certified Wood (if applicable): FSC Select for FSC Certified Wood</p>	<p>2nd Option: Select Glides (if applicable): See page 244 for glides. G Standard Glides SG Sliding Glides (\$55 upcharge)</p>	<p>3rd Option: Select the Upholstery (if applicable): See pages 245-246 for selections.</p>	<p>4th Option: Select the Side Upholstery for Two-tone models (if applicable): See pages 245-246 for selections.</p>	<p>5th Option: Select Veneer (if applicable): See page 244 for selections.</p>
---	---	---	--	---	---

Examples: S922S2LN.FSC.SG.ARR02
S922SOP.FSC.SG.UR26

RISE NEW ADDITIONS DIMENSIONS

GSA SIN 33721

Model Number	Overall			Tier 1			Tier 2			Ship Weight	Cubes	
	COM Yardage	Height	Width	Depth	Height	Width	Depth	Height	Width			Depth
S922S2LN	7.5	34"	36"	60"	17"	36"	40"	17"	36"	20"	120	56.5
S922S2LP	7.5	34"	36"	60"	17"	36"	40"	17"	36"	20"	120	56.5
S922SON	3.5	17"	36"	40"	17"	36"	40"	-	-	-	60	18.9
S922SOP	3.5	17"	36"	40"	17"	36"	40"	-	-	-	60	18.9
S922SOWN	3.5	17¼"	36"	40"	17"	36"	40"	-	-	-	95	14.8
S922SOWP	3.5	17¼"	36"	40"	17"	36"	40"	-	-	-	95	14.8
S922SWDN	3.5	17"	10"/40"	40" Sides	17"	10"/40"	40" Sides	-	-	-	45	18.9
S922SWDP	3.5	17"	10"/40"	40" Sides	17"	10"/40"	40" Sides	-	-	-	45	18.9
S922SWDWN	3.5	17¼"	39½"	37"	17"	10"/40"	40" Sides	-	-	-	77	15.0
S922SWDWP	3.5	17¼"	39½"	37"	17"	10"/40"	40" Sides	-	-	-	77	15.0
S922SHON	2.5	17"	36"	20"	17"	36"	20"	-	-	-	40	10.1
S922SHOWN	2.5	17¼"	36"	20"	17"	36"	20"	-	-	-	52	7.4



(See page 320 for COM pricing on Grades 9-22)

Description	Model Number	Base List Price	Upcharge List Price—Add to Base Price							
			2	3	4	5	6	7	8	
Arm Perch										
Non-Powered	S922SAN	\$ 2618	\$ 82	\$ 164	\$ 246	\$ 346	\$ 450	\$ 554	\$ 660	
Arm-Perch Wood Top										
Non-Powered	S922SAWN	\$ 2623	\$ 75	\$ 150	\$ 225	\$ 317	\$ 412	\$ 508	\$ 605	
Soft Wall										
Non-Powered	S922SWN	\$ 2618	\$ 79	\$ 157	\$ 236	\$ 342	\$ 446	\$ 552	\$ 657	
Lumbar Pillow										
Non-Powered	S922LPN	\$ 290	\$ 31	\$ 63	\$ 94	\$ 137	\$ 178	\$ 221	\$ 262	

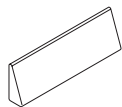
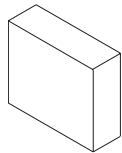
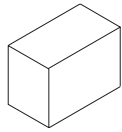

RISE

Single-tone Pricing Example:	Model/Options	Base Price/Upcharges
Step 1: Select Non-Powered Arm Perch	S922SAN	
Step 2: Select Seat Upholstery	Grade 6 Blazer	\$ 3068 w/upcharge
Add Base + applicable Upcharges for Total List Price =		\$ 3068

<p>How to specify — Select the Model Number from above.</p> <p>S 9 2 2 . F S C .</p>	<p>1st Option: FSC Certified Wood (if applicable):</p> <p>FSC Select for FSC Certified Wood</p>	<p>2nd Option: Select Glides (if applicable):</p> <p>See page 244 for glides.</p> <p>G Standard Glides</p> <p>SG Sliding Glides (\$55 upcharge)</p>	<p>3rd Option: Select the Upholstery (if applicable):</p> <p>See pages 245-246 for selections.</p>	<p>4th Option: Select the Side Upholstery for Two-tone models (if applicable):</p> <p>See pages 245-246 for selections.</p>	<p>5th Option: Select Veneer (if applicable):</p> <p>See page 244 for selections.</p>
---	--	--	---	--	--

Example:

Model Number	COM Yardage		Overall			Tier 1			Tier 2			Ship Weight	
	Height	Width	Depth	Height	Width	Depth	Height	Width	Depth	Ship Weight	Cubes		
S922SAN	3.5	26"	36"	40"	26"	36"	40"	-	-	-	45	14.9	
S922SAWN	3.5	26"	36"	20"	26"	36"	40"	-	-	-	60	10.8	
S922SWN	4.5	34"	13"	40"	-	-	-	-	-	-	45	13.8	
S922LPN	1.0	10"	36"	5"	-	-	-	-	-	-	5	1.8	



(See page 320 for COM pricing on Grades 9-22)

Description	Model Number	Base List Price		Upcharge List Price—Add to Base Price							
				2	3	4	5	6	7	8	
Two-Tone Chaise											
Non-Powered	S922S2LTN	\$ 3835	Seat Upholstery	\$ 79	\$ 159	\$ 238	\$ 342	\$ 447	\$ 553	\$ 660	
		\$ 3835	Side Upholstery	\$ 47	\$ 93	\$ 140	\$ 201	\$ 263	\$ 324	\$ 387	
Power-Ready	S922S2LTP	\$ 3927	Seat Upholstery	\$ 79	\$ 159	\$ 238	\$ 342	\$ 447	\$ 553	\$ 660	
		\$ 3927	Side Upholstery	\$ 47	\$ 93	\$ 140	\$ 201	\$ 263	\$ 324	\$ 387	
Two-Tone Full Ottoman											
Non-Powered	S922SOTN	\$ 2853	Seat Upholstery	\$ 55	\$ 111	\$ 167	\$ 239	\$ 312	\$ 386	\$ 462	
		\$ 2853	Side Upholstery	\$ 30	\$ 59	\$ 90	\$ 129	\$ 168	\$ 208	\$ 249	
Power-Ready	S922SOTP	\$ 2945	Seat Upholstery	\$ 55	\$ 111	\$ 167	\$ 239	\$ 312	\$ 386	\$ 462	
		\$ 2945	Side Upholstery	\$ 30	\$ 59	\$ 90	\$ 129	\$ 168	\$ 208	\$ 249	
Two-Tone Full Ottoman Wood Top											
Non-Powered	S922SOTWP	\$ 2955	Seat Upholstery	\$ 50	\$ 101	\$ 153	\$ 219	\$ 286	\$ 354	\$ 423	
		\$ 2955	Side Upholstery	\$ 27	\$ 54	\$ 82	\$ 118	\$ 154	\$ 190	\$ 228	
Power-Ready	S922SOTWN	\$ 2863	Seat Upholstery	\$ 50	\$ 101	\$ 153	\$ 219	\$ 286	\$ 354	\$ 423	
		\$ 2863	Side Upholstery	\$ 27	\$ 54	\$ 82	\$ 118	\$ 154	\$ 190	\$ 228	
Two-Tone Half-Ottoman											
Non-Powered	S922SHOTN	\$ 2454	Seat Upholstery	\$ 44	\$ 88	\$ 132	\$ 190	\$ 248	\$ 307	\$ 366	
		\$ 2454	Side Upholstery	\$ 17	\$ 34	\$ 52	\$ 74	\$ 96	\$ 119	\$ 142	
Two-Tone Half Ottoman Wood Top											
Non-Powered	S922SHOTWN	\$ 2454	Seat Upholstery	\$ 44	\$ 88	\$ 132	\$ 190	\$ 248	\$ 307	\$ 366	
		\$ 2454	Side Upholstery	\$ 17	\$ 34	\$ 52	\$ 74	\$ 96	\$ 119	\$ 142	
Two-Tone Arm Perch											
Non-Powered	S922SATN	\$ 2889	Seat Upholstery	\$ 64	\$ 128	\$ 192	\$ 268	\$ 353	\$ 438	\$ 525	
		\$ 2889	Side Upholstery	\$ 24	\$ 50	\$ 76	\$ 104	\$ 137	\$ 171	\$ 204	
Two-Tone Arm Perch Wood Top											
Non-Powered	S922SATWN	\$ 2889	Seat Upholstery	\$ 64	\$ 128	\$ 192	\$ 268	\$ 353	\$ 438	\$ 525	
		\$ 2889	Side Upholstery	\$ 24	\$ 50	\$ 76	\$ 104	\$ 137	\$ 171	\$ 204	
Two-Tone Soft Wall											
Non-Powered	S922SWTN	\$ 2889	Top/Front/Back	\$ 31	\$ 60	\$ 90	\$ 128	\$ 167	\$ 207	\$ 247	
		\$ 2889	Side Upholstery	\$ 52	\$ 102	\$ 153	\$ 218	\$ 285	\$ 353	\$ 419	

How to specify — Select the Model Number from above.	1st Option: FSC Certified Wood (if applicable): FSC Select for FSC Certified Wood	2nd Option: Select Glides (if applicable): See page 244 for glides G Standard Glides SG Sliding Glides (\$55 upcharge)	3rd Option: Select the Upholstery See pages 245-246 for selections.	4th Option: Select the Side Upholstery for Two-tone models (if applicable): See pages 245-246 for selections.	5th Option: Select Veneer (if applicable): See page 244 for selections.
S 9 2 2 . F S C .					

Example: S922S2LTN.FSC.SG.ARR02

Model Number		Overall				Tier 1			Tier 2			Ship Weight	Cubes
		COM Yardage	Height	Width	Depth	Height	Width	Depth	Height	Width	Depth		
S922S2LTN	Seat	4.0	34"	36"	60"	17"	36"	40"	17"	36"	20"	120	56.5
	Side	3.0											
S922S2LTP	Seat	4.0	34"	36"	60"	17"	36"	40"	17"	36"	20"	120	56.5
	Side	3.0											
S922SOTN	Seat	2.5	17"	36"	40"	17"	36"	40"	-	-	-	60	18.9
	Side	1.5											
S922SOTP	Seat	2.5	17"	36"	40"	17"	36"	40"	-	-	-	60	18.9
	Side	1.5											
S922SOTWP	Seat	2.5	17¼"	36"	40"	17"	36"	40"	-	-	-	95	14.8
	Side	1.5											
S922SOTWN	Seat	2.5	17¼"	36"	40"	17"	36"	40"	-	-	-	95	14.8
	Side	1.5											
S922SHOTN	Seat	2.0	17"	36"	20"	17"	36"	20"	-	-	-	40	10.1
	Side	1.0											
S922SHOTWN	Seat	2.0	17¼"	36"	20"	17"	36"	20"	-	-	-	52	7.4
	Side	1.0											
S922SATN	Seat	2.5	26"	36"	40"	26"	36"	40"	-	-	-	45	14.9
	Side	1.0											
S922SATWN	Seat	2.5	26"	36"	20"	26"	36"	40"	-	-	-	60	10.8
	Side	1.0											
S922SWTN	Seat	2.0	34"	13"	40"	-	-	-	-	-	-	4.5	13.8
	Side	2.5											



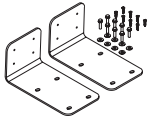

Description	Model Number	Base List Price	Ship Weight	Cubes
Rise Accessories				
Ganging Bracket	S922GB	\$ 247	25	0.8

RISE

<p>How to specify — Select the Model Number from above.</p> <p>S 9 </p>	<p><i>1st Option:</i> FSC Certified Wood <i>(if applicable):</i> FSC Select for FSC Certified Wood</p> <p>F S C .</p>	<p><i>2nd Option:</i> Select the Laminate <i>(if applicable):</i> See page 244 for options.</p> <p>L </p>	<p><i>3rd Option:</i> Select the Edge Color <i>(if applicable):</i> See page 244 for options.</p> <p> </p>	<p><i>4th Option:</i> Select the Base Paint Color <i>(if applicable):</i> See page 244 for options.</p> <p> </p>
---	--	---	---	---

WOOD FINISH

WOOD SPECIES

PATTERN NAME	MAPLE
Beigewood.....	LE878
Belair.....	LE934
Burnished Cherry	LE777
Cinnamon Cherry	LE260
Clear Coat.....	LE100
Clear Oak	LE300
Clear/Natural Maple.....	LE800
Dark Rift Cut Oak.....	LE331
Ebony Maple.....	LE555
Field Elm.....	LE599
Florence Walnut.....	LE579
Harvest Maple	LE856
Light Cherry.....	LE701
Light Walnut.....	LE601
Lowell Ash	LE394
Medium Red Cherry	LE512
Natural Cherry.....	LE222
Nutmeg Walnut	LE629
Phantom Ecrú	LE912
Pinnacle Walnut	LE679
Portico Teak.....	LE150
Shaker Cherry	LE774
Skyline Walnut.....	LE625
Sumatra Walnut.....	LE693

RETREAT

NOTE: Refer to individual product pages for upcharges.

FSC Certified Wood at Allsteel
See page [459](#) for more information.

Retreat Standard Upholstery Selections by Model/Series, for all other seating see *Seating, Collaboration, and Tables* pages 13-14.

		Executive/Conference Seat	Executive/Conference Seat	Wing Back Seat	Wing Back Body	Hi/Low/Ottoman Seat-Top	Hi/Low/Ottoman Side-Body
GRADE 1							
Apex	APX	•	•	•		•	
Centurion	CU	•	•	•	•	•	•
Contourett	UR	•	•	•		•	•
Dapper	DAPR	•	•	•		•	•
Ensemble	ENSB	•	•	•		•	•
Hamilton <i>(De-emphasized)</i>	HAML	•	•	•	•	•	•
Inertia <i>(De-emphasized)</i>	NR	•	•	•		•	•
GRADE 2							
Appoint Seating	PNS	•	•	•		•	•
Blume	BLME	•	•	•	•	•	•
Clyde	CLYD	•	•	•	•	•	•
Dotty <i>(De-emphasized)</i>	DOT	•	•	•		•	•
Meld	SMHMLD	•	•	•	•	•	•
Rush	RUSH	•	•	•	•	•	•
Spin	SPNN	•					
Whisper Vinyl	WP	•	•				
GRADE 3							
Lateral	SCFSLAT	•		•		•	
Moxie	SX	•	•	•		•	•
Purl	PURL	•	•	•		•	•
Quill	QUL	•	•	•	•	•	•
GRADE 4							
Caper	SMHMCAP	•	•	•		•	•
Manner	SMHMMAN	•	•	•	•	•	•
Merit	SMHMMER	•	•	•	•	•	•
Messenger	SMHMGRM	•		•	•	•	•
Metric	SMHMMET	•		•	•	•	•
Mode	SMHMMOD	•	•	•	•	•	•
Multiply	SMHMMLT	•		•		•	
Murmur	SMHMMUR	•		•		•	
Muse	SMHMMUS	•		•		•	
Trundle	SMHMTRN	•		•		•	

		Executive/Conference Seat	Executive/Conference Seat	Wing Back Seat	Wing Back Body	Hi/Low/Ottoman Seat-Top	Hi/Low/Ottoman Side-Body
GRADE 5							
Main Line Flax	SCAMMLF	•	•	•		•	•
Rove	SMHMROV	•		•		•	
GRADE 6							
Arris	ARR	•	•	•	•	•	•
Blazer	SCAMBLZ	•	•	•	•	•	•
Chock	SMHMCKK	•		•		•	
Hedge	SMHMHED	•	•	•		•	•
Hemp	SCAMHMP	•	•	•		•	
Pocket	SMHMPKT	•		•		•	
Maharam Sequence	SMHMSQN	•		•		•	
Tandem	SMHMTAN	•		•		•	
GRADE 7							
Silk	SCAMSLK	•	•	•	•	•	•
GRADE 8							
Apt	SMHMAPT	•		•		•	
Brisa	RS	•	•	•		•	•
Zap	SCAMZAP	•	•	•		•	•
GRADE 9							
Ultraleather Pro	SUF554	•	•	•		•	•
Yoredale	SCAMYDL	•	•	•	•	•	•
GRADE L1							
Florence	FLOR					•	•
Strasburg	STB	•	•			•	•



☞ Partnership Program — See page 10 for details.
 • Available upholstery option

- Allsteel fabrics and foam meet requirements for CTB117.
- Blank spaces indicate that a product has not yet been tested or that it failed.
- Contact Allsteel Customer Support for other flammability code approvals.

Retreat Lounge is a space-defining collection that supports real work in often underutilized spaces. It defines areas for small groups, provides privacy for individuals, and offers visual consistency in space planning. The lounge collection includes wing-back, high-back, and low-back chairs, and a matching ottoman.

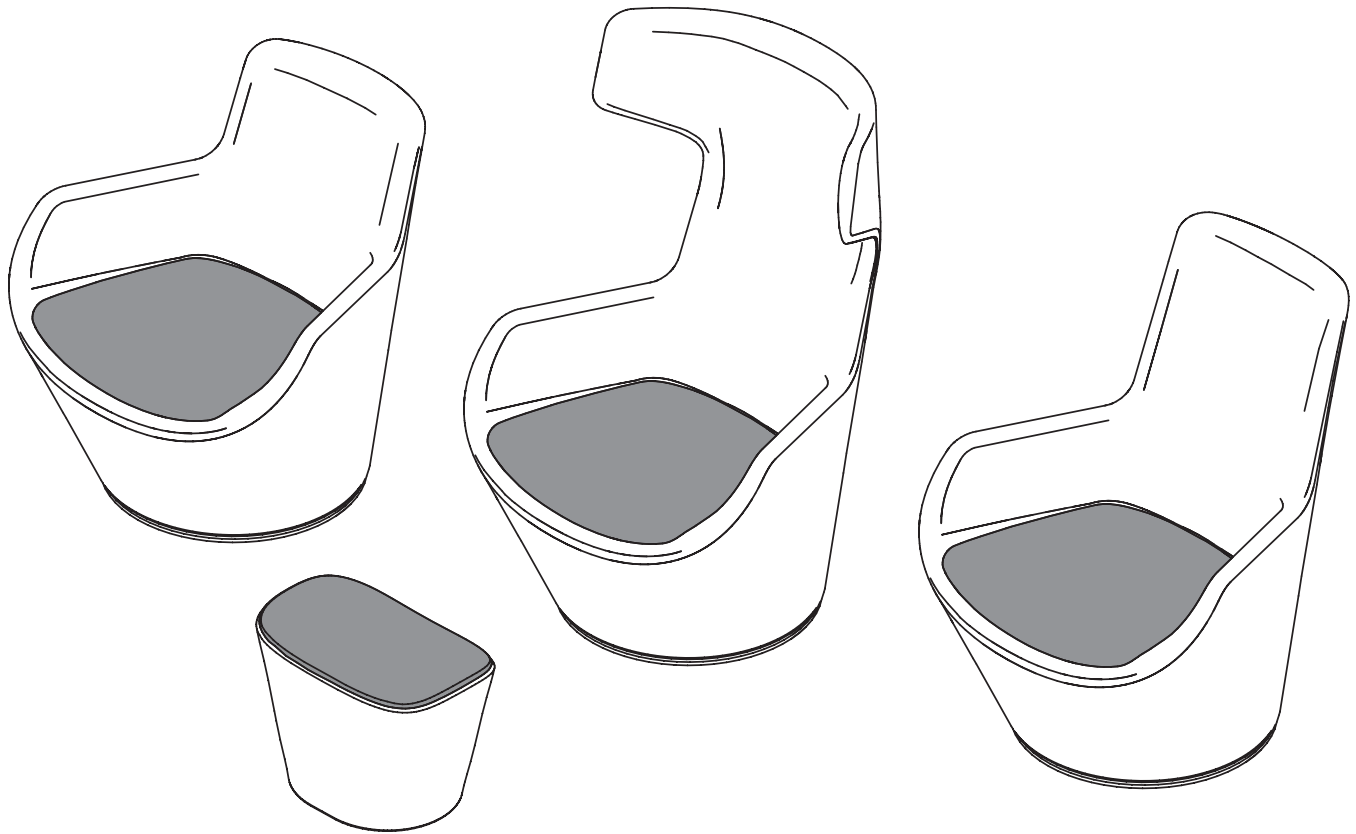

Retreat Executive, Conference and Side seating extends premium comfort throughout meeting and private office spaces with its iconic design know from the Retreat lounge collection. The soft, organic shape of Retreat speaks to multiple generations of leaders, while creating a timeless and cohesive aesthetic that does not overwhelm the space or user.



RETREAT

DESIGN FEATURES

Retreat is a space defining lounge collection that supports real work in often underutilized spaces. It defines space for small groups, provides privacy for individuals, and visual consistency in planning and varied elevations.

Arms

Arm height is specific for comfort or laptop placement.

High-Back and Wing-Back

High-back protects back of head and wing-back provides added visual privacy. Relaxed tailoring is normal and expected in the upper headrest of the wing back (see illustration below).

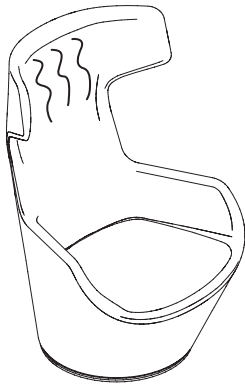

Base Options for Chairs

Select between fixed, swivel, or return-to-center base.

Materials

- All COMs/COLs must be approved for upholsterability or applicable fire code compliance prior to order entry. See pages 6-8 for COM ordering instructions.
- Allsteel fabrics meet requirements for CTB117. COM/COL manufacturers supply certificates of compliance for fabric-only tests such as CTB117.

OPTIONS

Chair Type:

- VERW** Wing-Back Upholstery
- VERH** High-Back Upholstery
- VERL** Low-Back Upholstery
- VERO** Ottoman Upholstery

Fire Code:

- NO** Standard Upholstery, No Fire Code

Base Type (if applicable):

- F** Fixed (Subtract \$327)
- S** Swivel
- R** Return-to-Center (\$289 extra)

Body Upholstery:

See page 261 for upholstery selection. Future “Non-stretch” fabrics will require dual zippers on wing back models (see illustration below).

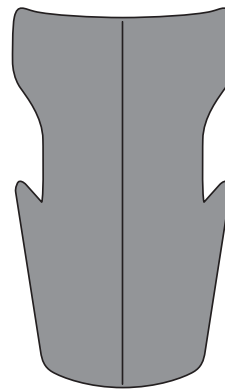

Single Zipper

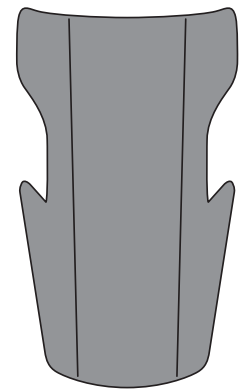





Dual Zipper

Seat Upholstery and Leather:

See page 261 for upholstery and leather selection.



Upcharges listed for Grades 2 and above, add to Base Price. Grades 9-22 on page 321.

Style	Model Number <i>Add options below</i>	Textiles	Base Price	Upholstery Upcharge	Upcharges							
					2	3	4	5	6	7	8	L1
	VERWNO	Upholstery	\$ 5569	Body	\$ 63	\$ 126	\$ 189	\$ 273	\$ 357	\$ 441	\$ 525	N/A
				Seat	\$ 16	\$ 31	\$ 47	\$ 68	\$ 89	\$ 111	\$ 131	N/A
	VERHNO	Upholstery	\$ 4800	Body	\$ 47	\$ 94	\$ 142	\$ 204	\$ 268	\$ 331	\$ 394	\$ 938
				Seat	\$ 16	\$ 31	\$ 47	\$ 68	\$ 89	\$ 111	\$ 131	\$ 313
	VERLNO	Upholstery	\$ 4416	Body	\$ 43	\$ 86	\$ 128	\$ 185	\$ 241	\$ 298	\$ 355	\$ 906
				Seat	\$ 15	\$ 29	\$ 43	\$ 62	\$ 80	\$ 100	\$ 118	\$ 313
	VERONO	Upholstery	\$ 1843	Body	\$ 23	\$ 47	\$ 71	\$ 102	\$ 133	\$ 165	\$ 197	\$ 469
				Seat	\$ 16	\$ 31	\$ 47	\$ 68	\$ 89	\$ 111	\$ 131	\$ 313

Example of upcharges: Model VERWNO with Grade 5 Body and Grade 2 Seat = \$5569 + \$273 + \$16 = \$5858 Total

RETREAT

<p>How to specify — Select the Model Number from above.</p> <p>VER NO . .</p>	<p>1st Option Select the Base Type (if applicable): F Fixed (Subtract \$327) S Swivel R Return to Center (\$289 extra)</p>	<p>2nd Option Select the Body Upholstery: See page 261 for selections and Color Codes. See Seating Price List for COM Guidelines.</p>	<p>3rd Option Select the Seat Upholstery: See page 261 for selections and Color Codes. See Seating Price List for COM Guidelines.</p>
--	---	--	--

Examples: VERWNO.F.CLYD04.CLYD04
VERONO.CLYD01.CLYD10

VERLNO.R.CLYD13.RS10

Model Number	COM Yardage		Overall				Seat			Armrests				Backrest				Ship Weight Per Carton	Cubes	
	COL Sp. Feet	Height (Range)	Width	Depth	Height	Width	Depth (Cushion)	Pan Angle (Range)	Armrest Height	Width Between Arms	Armrest Length	Armrest Serback	Height	Width	Lumbar Height	Backrest/Seat Angle	Ship Weight			
VERWNO	4.0 1.0		46"	30½"	32½"	17½"	20"	19½"	5.8°	7½"	19½"	13"	6½"	32"	16½"	9"	102.4°	95	95	31.9
VERHNO	3.0 1.0		37"	30½"	32½"	17½"	20"	19½"	6.8°	7½"	19½"	13"	6½"	26½"	16½"	9"	102.4°	93	93	29.9
VERLNO	3.0 1.0		30½"	30½"	32½"	17½"	20"	19½"	6.8°	7½"	19½"	13"	6½"	20"	16½"	9"	102.4°	90	90	18.8
VERONO	1.5 1.0		16"	23"	15"													60	60	5.2

NOTE: Dimensions are in accordance with BIFMA G1-2002 guidelines — see illustration of guidelines on page 45.



Upcharges listed for Grades 2 and above, add to Base Price. Grades 9-22 on page 321.

Description	Model Number <i>Add options below</i>	Base Price	Upholstery	Upcharge								
				2	3	4	5	6	7	8	L1	
Retreat Single Upholstery												
Retreat Exec/Conf Mid-Back Single Upholstery	RETECMS	\$ 3347	Body/Seat	\$ 63	\$ 126	\$ 189	\$ 273	\$ 357	\$ 441	\$ 525	\$ 1214	
Retreat Exec/Conf Low-Back Single Upholstery	RETECLS	\$ 2893	Body/Seat	\$ 47	\$ 94	\$ 142	\$ 204	\$ 268	\$ 331	\$ 394	\$ 910	
Retreat Wood Side Mid-Back Single Upholstery	RETWMS	\$ 3636	Body/Seat	\$ 63	\$ 126	\$ 189	\$ 273	\$ 357	\$ 441	\$ 525	\$ 1214	
Retreat Wood Side Low-Back Single Upholstery	RETWLS	\$ 3470	Body/Seat	\$ 47	\$ 94	\$ 142	\$ 204	\$ 268	\$ 331	\$ 394	\$ 910	
Retreat Multi Upholstery												
Retreat Exec/Conf Mid-Back Multi Upholstery	RETECMM	\$ 3508	Body	\$ 47	\$ 94	\$ 142	\$ 204	\$ 268	\$ 331	\$ 394	\$ 910	
			Seat	\$ 16	\$ 31	\$ 47	\$ 68	\$ 89	\$ 111	\$ 131	\$ 304	
Retreat Exec/Conf Low-Back Multi Upholstery	RETECLM	\$ 3029	Body	\$ 31	\$ 63	\$ 94	\$ 137	\$ 178	\$ 221	\$ 262	\$ 607	
			Seat	\$ 16	\$ 31	\$ 47	\$ 68	\$ 89	\$ 111	\$ 131	\$ 304	
Retreat Wood Side Mid-Back Multi Upholstery	RETWMM	\$ 3784	Body	\$ 47	\$ 94	\$ 142	\$ 204	\$ 268	\$ 331	\$ 394	\$ 910	
			Seat	\$ 16	\$ 31	\$ 47	\$ 68	\$ 89	\$ 111	\$ 131	\$ 304	
Retreat Wood Side Low-Back Multi Upholstery	RETWLM	\$ 3595	Body	\$ 31	\$ 63	\$ 94	\$ 137	\$ 178	\$ 221	\$ 262	\$ 607	
			Seat	\$ 16	\$ 31	\$ 47	\$ 68	\$ 89	\$ 111	\$ 131	\$ 304	

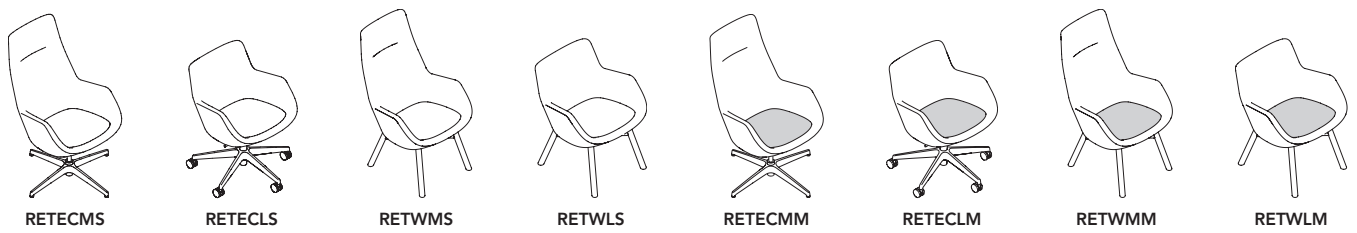

Pricing Example:	Model/Options	Base Price/Upcharges
Step 1: Select Model	RETECMM	\$ 3508
Step 2: Select Base Type	5	\$ 55 upcharge
Step 3: Select Paint Color	POL	\$ 55 upcharge
Step 4: Select Seat Upholstery	Grade 3	\$ 31 upcharge
Step 5: Select Body Upholstery	Grade 5	\$ 204 upcharge
Add Base + applicable Upcharges for Total List Price =		\$ 3853

Retreat Executive | Conference

<p>How to specify — Select the Model Number from above.</p>	<p>1st Option: Select Base Type: 5 5-Star (\$55 upcharge) 4 4-Star Return-to-Center</p>	<p>2nd Option: Select Paint Color: P71 Black POL Polished (\$55 upcharge)</p>	<p>3rd Option: Select the Upholstery for Single Upholstery Models: See Allsteel upholstery matrix on page 261.</p>
<p>R E T E C . .</p>			

Example: RETECMS.4.P71.CLYD07

Retreat Executive | Conference

<p>How to specify — Select the Model Number from above.</p>	<p>1st Option: Select Base Type: 5 5-Star (\$55 upcharge) 4 4-Star Return-to-Center</p>	<p>2nd Option: Select Paint Color: P71 Black POL Polished (\$55 upcharge)</p>	<p>3rd Option: Select the Body Upholstery for Multi-Upholstery Models: See Allsteel upholstery matrix on page 261.</p>	<p>4th Option: Select the Seat Upholstery for Multi-Upholstery Models: See Allsteel upholstery matrix on page 261.</p>
<p>R E T E C M . .</p>				

Example: RETECMM.5.POL.SCAMBLZ08.CLYD09

Model Number	Overall				Seat				Arms				Backrest								
	Ship Weight	Cubes	COM Yardage*	Height	Width	Depth	Height	Width	Depth	Pan Angle (Range)	Armrest Height	Armrest Length	Width Between Armrests Up	Width Between Armrests Down	Armrest Pads	Armrest Swivel	Armrest Pivot	Height	Width	Lumbar Height	Backrest Inclination from Vertical
RETECM_	60	29.9	4	43"-46½"	27"	27"	18½"-21"	15"	19"	3°-17°	7½"	10½"	15"	22"	7"	0	27"	15"	10"	15°-29°	102°
RETECL_	50	18.8	3	31¼"-34"	27"	27"	18½"-21"	15"	19"	3°-17°	7½"	10½"	15"	22"	7"	0	16½"	15"	10"	15°-29°	102°
RETWM_	55	37.7	4	43"	27"	27"	18½"	15"	19"	3°	7½"	10½"	15"	22"	7"	0	27"	15"	10"	15°	102°
RETWL_	45	26.6	3	31¼"	27"	27"	18½"	15"	19"	3°	7½"	10½"	15"	22"	7"	0	16½"	15"	10"	15°	102°

*COM Yardage is listed for total yardage/feet required for a model, with applicable yardage/feet for individual components listed.



Retreat Wood Side

<p>How to specify — Select the Model Number from above.</p>	<p>1st Option: Select Wood Finish: See Allsteel wood finishes on page 260.</p>	<p>2nd Option: Select the Upholstery for Single Upholstery Models: See Allsteel upholstery matrix on page 261.</p>	
<p>R E T W S .</p>	<p> .</p>	<p> .</p>	

Example: RETELS.LE800.SCAMBLZ08

Retreat Executive | Conference

<p>How to specify — Select the Model Number from above.</p>	<p>1st Option: Select Wood Finish: See Allsteel wood finishes on page 260.</p>	<p>2nd Option: Select the Body Upholstery for Multi-Upholstery Models: See Allsteel upholstery matrix on page 261.</p>	<p>3rd Option: Select the Seat Upholstery for Multi-Upholstery Models: See Allsteel upholstery matrix on page 261.</p>
<p>R E T W S .</p>	<p> .</p>	<p> .</p>	<p> .</p>

Example: RETWMM.LA100.STB05.STB17

Social Collaborative Standard Upholstery Selections by Model/Series, for all other seating see pages 13-14.

Parallel

Parallel

LEATHER L1

Allsteel Leather	WTH	•
Florence Leather	FLOR	•

GRADE 1

Apex	APX	
Centurion	CU	
Contourett	UR	•
Dapper	DAPR	•
Hamilton <i>(De-emphasized)</i>	HAM	•
Inertia <i>(De-emphasized)</i>	NR	•
Optic <i>(De-emphasized)</i>	OP	

GRADE 2

Appoint Seating	PNS	
Blume	BLME	•
Clyde	CLYD	•
Dotty <i>(De-emphasized)</i>	DOT	•
Meld	SMHMMLD	•
Rush	RUSH	•
Spin Seating	SPNN	•
Whisper Vinyl	WP	•

GRADE 3

Lateral	SCFSLAT	•
Moxie	SX	•
Purl	PURL	•
Quill	QUL	•

GRADE 4

Caper	SMHMCAP	•
Manner	SMHMMAN	•
Merit	SMHMMER	•
Messenger	SMHMGRM	•
Metric	SMHMMET	•
Mode	SMHMMOD	•
Multiply	SMHMMLT	•
Murmur	SMHMMUR	
Muse	SMHMMUS	
Trundle	SMHMTRN	•

GRADE 5

Main Line Flax	SCAMMLF	•
Rove	SMHMROV	•

GRADE 6

Arris	ARR	•
Blazer	SCAMBLZ	•
Chock	SMHMCKK	
Hedge	SMHMHEd	•
Pocket	SMHMpKT	•
Sequence	SMHMSQN	
Tandem	SMHMTAN	
Verse	SCARVRS	•

GRADE 8

Apt	SMHMpT	•
Brisa	RS	•

GRADE 9

Ultraleather Pro	SUF554	•
------------------	--------	---

GRADE 11

Fusion	SCARFUS	•
--------	---------	---

GRADE 13

Maze	SCARMZE	•
------	---------	---

GRADE 14

Chroma	SCARCHR	•
--------	---------	---

PARALLEL

⊕ Partnership Program — See page 10 for details.

≠ Upholstery will be Railroad cut.

- Available upholstery option

**FRAMES & TABLE BASE
PAINT FINISHES**

GRADE P1	
Carbon.....	P4Q
Designer White.....	PJW
GRADE P2	
Pyrite.....	PJE
Silver.....	PR6
GRADE P4	
Polished Chrome.....	POL

**ARM SLEEVES
PAINT FINISHES**

GRADE P1	
Black.....	P71
Brownstone.....	P7D
Carbon.....	P4Q
Cinder.....	P7Q
Cove.....	P096
Designer White.....	PJW
Dune.....	P094
Flint.....	P02
Fossil.....	P28
Harbor.....	P097
Loft.....	P7B
Muslin.....	P4J
Parchment.....	P93
Pebble.....	P8R
Pewter.....	P8D
Sage.....	P095
Salt.....	P8C
Titanium.....	P8T/T
GRADE P2	
Champagne Metallic.....	PR5
Gunmetal Metallic.....	PR3
Night Bronze.....	P8B
Platinum Metallic.....	PR2
Pyrite.....	PJE
Silver.....	PR6
Solar Black.....	P8X
GRADE P3	
Atom.....	P8S
Blossom.....	P8K
Bullseye.....	PJF
Cabernet.....	P7T
Conifer.....	P8H
Ember.....	P8P
Ion.....	P8N
Iris.....	P8J
Krypton.....	P8F
Regatta.....	P8M
Succulent.....	P8A

LAMINATES

GRADE L1	
SOLID COLORS	
Black.....	P
Designer White.....	LDW1
Flint.....	LM16
Fossil Shale.....	LEH1
Loft.....	LM11
Muslin.....	LM15
Titanium.....	LTI1
WOODGRAIN	
Belair.....	LWBA
Bourbon Cherry.....	H
Field Elm.....	LWFE
Florence Walnut.....	LFW1
Kingswood Walnut.....	LK1
Natural Maple.....	LWD
NeoWalnut.....	LNU1
Pinnacle.....	PINC
Shaker Cherry.....	LW7C
GRADE L2	
Beigewood.....	LWBE
Fawn Cypress.....	LFC1
Lowell Ash.....	LLA1
Mangalore Mango.....	LMM1
Natural Recon.....	LNR1
Phantom Charcoal.....	LPC1
Phantom Ecu.....	LPE1
Portico Teak.....	LPT1
Skyline Walnut.....	LSW1
Veranda Teak.....	LVT1
GRADE L3	
Natural Walnut.....	LWNW

SOLID SURFACE

Designer White.....	SDW4
Frosty White.....	SFW3
Night Stars.....	SNS5
Masoned Concrete.....	SMC2
Monte Amiata.....	SMA1

LAMINATE EDGE COLORS

Beigewood.....	DE
Belair.....	BA
Black.....	E4
Bourbon Cherry.....	H
Brownstone.....	EY
Bungalow.....	EX
Designer White.....	DW
Fawn Cypress.....	FC
Field Elm.....	FE
Flint.....	E9
Florence Walnut.....	FW
Fossil.....	EH
Kingswood Walnut.....	KI
Loft.....	EV
Lowell Ash.....	DL
Mangalore Mango.....	MM
Muslin.....	EU
Natural Maple.....	DD
Natural Recon.....	NR
Natural Walnut.....	DN
NeoWalnut.....	NU
Parchment.....	EN
Phantom Charcoal.....	PC
Phantom Ecu.....	PE
Pinnacle.....	PI
Portico Teak.....	DP
Shaker Cherry.....	DF
Skyline Walnut.....	SW
Titanium.....	TI
Veranda Teak.....	VT

**STRATAWOOD
VENEERS**

GRADE V2	
CHERRY	
Cinnamon/Biltmore Cherry.....	SC260
Lowell Ash.....	SC394
Clear Cherry.....	SC700
Light Cherry.....	SC701
Shaker Cherry.....	SC774
Burnished Cherry.....	SC777
MAPLE	
Field Elm.....	SE599
Clear Maple***.....	SE800
Harvest Maple.....	SE856
Beigewood.....	SE878
Phantom Ecu.....	SE912
Belair.....	SE934
OAK	
Clear Oak.....	SF300
Dark Rift Cut Oak.....	SF331
SILVER OAK	
Silver Oak Clear.....	SB100
Portico Teak.....	SB150
WALNUT	
Florence Walnut.....	ST579
Light Walnut.....	ST601
Skyline Walnut.....	ST625
Pinnacle Walnut.....	ST679
Sumatra Walnut.....	ST693

**NATURAL VENEERS —
FLAT CUT**

GRADE V2	
CHERRY	
Cinnamon/Biltmore Cherry.....	NC260
Lowell Ash.....	NC394
Medium Red Cherry.....	NC512
Light Cherry.....	NC701
Shaker Cherry.....	NC774
Burnished Cherry.....	NC777
MAPLE	
Clear Maple.....	NE800
Harvest Maple.....	NE856
WALNUT	
Ebony Walnut.....	NT509
Florence Walnut.....	NT579
Light Walnut.....	NT601
Skyline Walnut.....	NT625
Nutmeg Walnut.....	NT629
Pinnacle Walnut.....	NT679
Sumatra Walnut.....	NT693

**NATURAL VENEERS —
RIFT CUT**

GRADE V3	
Fawn Cypress Rift Cut Oak.....	RF108
Light Rift Cut Oak.....	RF301
Dark Rift Cut Oak.....	RF331
Phantom Ecu Rift Cut Oak.....	RF912

NOTE: Refer to individual product pages for upcharges.

FSC Certified Wood at Allsteel
See page 459 for more information.

PARALLEL

Introducing Parallel, a collection of soft seating and coordinating tables that adapts to a variety of spaces. Parallel is at home in reception areas and collaborative workspaces, accommodating different functions while maintaining a consistent aesthetic. With HBF Textiles, Allsteel fabrics, or a designer's own material, Parallel provides a canvas to make a strong first impression anywhere it's used.

Designed in partnership with Chris Adamick.

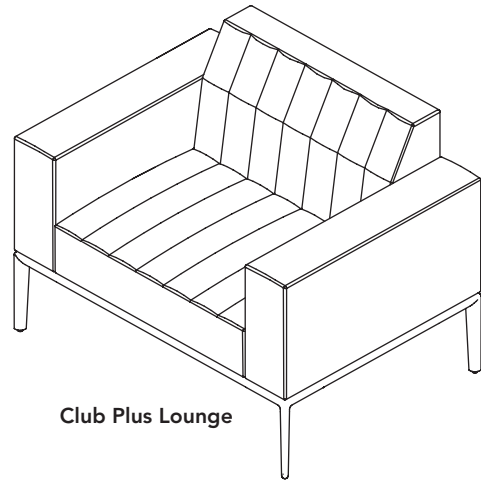

Club Plus Lounge

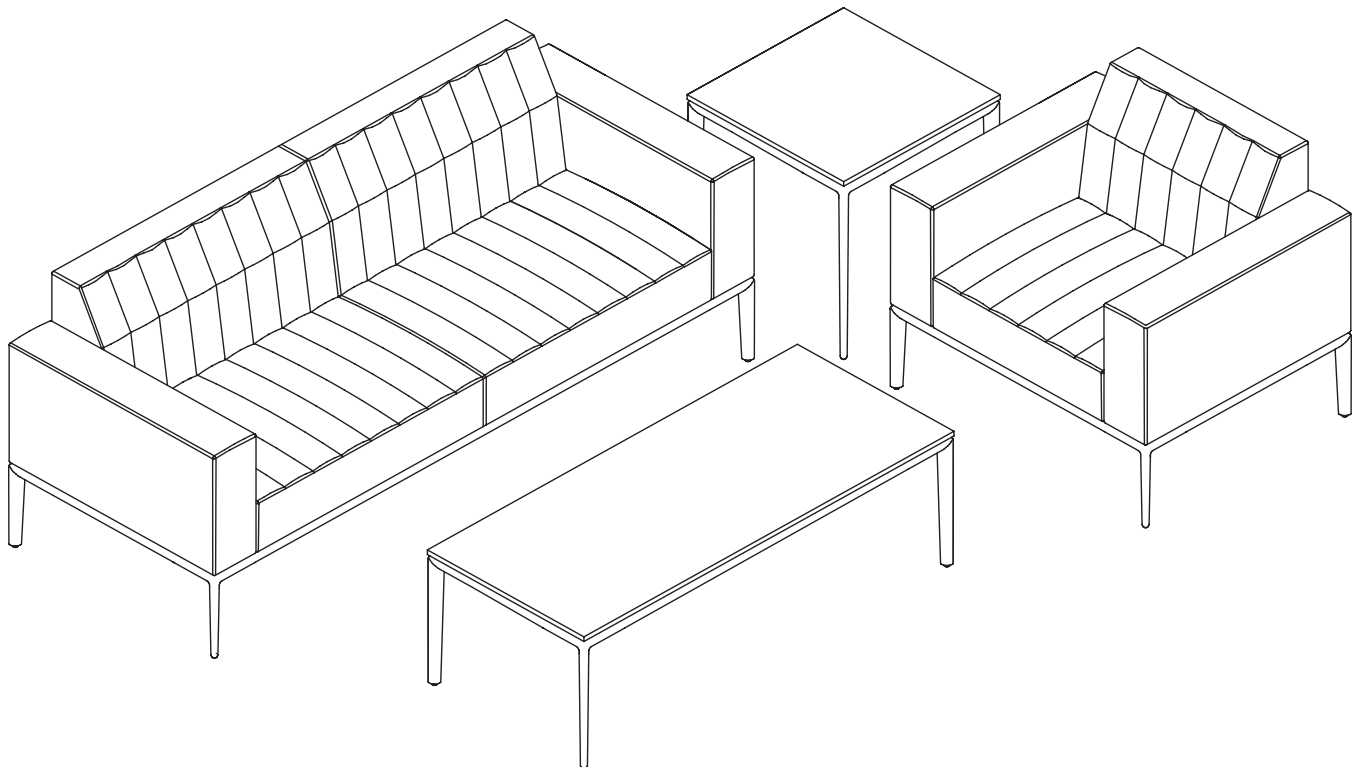

PARALLEL

DESIGN FEATURES

Functional Versatility

Flexible and functional, Parallel soft seating can be considered a workhorse in helping meet a company's workplace needs, whether it be casual conference areas, lobby and reception settings, or collaborative hubs.

The variety of sizing and features allows Parallel to adapt from reception to collaborative areas throughout a workspace. The clean lines work well with current and future furniture settings. Generous sizing and thoughtful comfort considerations make the sit comfortable for five minutes or two hours.

Design Versatility

Cutting a sleek profile with tapered ellipse legs and a slim, stylistic reveal, Parallel is intended to work with your favorite Allsteel platforms without overpowering the space. The sharp tailoring of the upholstery paired with the dual-density foam means comfort without sacrificing aesthetics.

The Parallel club chair, club plus lounge, and modular sofa options, as well as the coordinating side and coffee tables, enable a diverse array of setups, from structured stylized formal, to a warmer domesticated corporate vibe, to flexible collaborative in combination with other Allsteel products. A variety of upholstery materials and frame colors celebrates beautiful form while telling a strong design story.

Wide Arms

6" wide arms with high-density foam allow for a comfortable surface for device usage, and the optional removable sleeve accessory, available in three finishes, makes a stable worksurface on the arm. Designed for comfort but also with the intent that all surfaces are sitting surfaces, Parallel is built to handle perching on the arms and back.

Design Nuances

- Legs – Ellipse, tapered shape set to the very edge of the frame
- Reveal – Slim reveal around the entire perimeter
- Tailored upholstery – Available with a channeled design detail for a more refined aesthetic

Materials

- All COMs/COLs must be approved for upholsterability or applicable fire code compliance prior to order entry. See pages 6-8 for COM ordering instructions.
- Allsteel fabrics meet requirements for CTB117. COM/COL manufacturers supply certificates of compliance for fabric-only tests such as CTB117.

Tables (page 276)

- Available with laminate, veneer or solid surface tops.
- Leg finish option includes painted (color specified) or polished chrome.

OPTIONS

Seat and Back Upholstery:

C Channeled

Base Colors:

P4Q Carbon

PR6 Silver

PJW Designer White

PJE Pyrite

POL Polished Chrome

FSC Certified Wood:

FSC FSC Certified Wood

Seat and Back Upholstery:

See page 268 for colors and codes

Optional Arm Sleeve Paint Colors:

P1 P2 P3

See page 269 for colors and codes

Table Bases:

P4Q Carbon

PR6 Silver

PJW Designer White

PJE Pyrite

POL Polished Chrome

Laminate Tabletops:

L1 Solid / Woodgrain

L2 Woodgrain

L3 Textured Woodgrain

See page 269 for finishes and codes

Veneer Tabletops:

V2 Stratawood

V2 Natural – Flat Cut

V3 Natural – Rift Cut

See page 269 for finishes and codes

Solid Surface Tabletops:

Grade A

SFW3 Frosty White

Grade B

SDW4 Designer White

Grade C

SNS5 Night Starts

Grade D

SMC2 Masoned Concrete

SMA1 Monte Amiata

More solid surface colors available as specials. Contact AllsteelFinishes@allsteeloffice.com for Corian and Wilsonart catalogs.

(See page 321 for COM pricing on Grades 9-22)

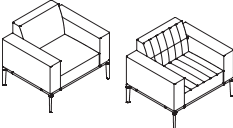
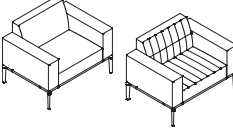
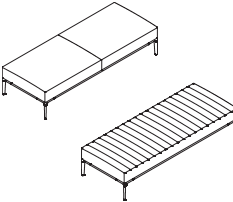
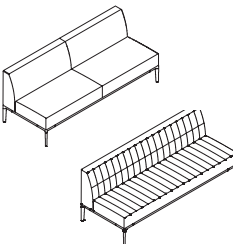
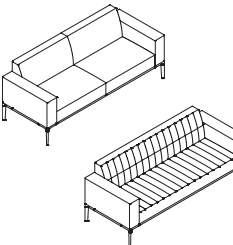
Description	Upholstery	Model Number		Base		Upcharge List Price – Add to Base Price						
		Old	New	List Price	2	3	4	5	6	7	8	L1 Leather
Club Chair 	Non-Channel	CLCNO	PSCN	\$ 4075	\$ 71	\$ 142	\$ 213	\$ 307	\$ 402	\$ 496	\$ 591	\$ 1365
	Channeled	CLCCNO	PSCC	\$ 4497	\$ 71	\$ 142	\$ 213	\$ 307	\$ 402	\$ 496	\$ 591	\$ 1365
Club Plus Chair 	Non-Channel	CLCPNO	PSCPNO	\$ 4356	\$ 82	\$ 163	\$ 245	\$ 353	\$ 462	\$ 571	\$ 678	\$ 1614
	Channeled	CLCPCNO	PSCPC	\$ 4779	\$ 82	\$ 163	\$ 245	\$ 353	\$ 462	\$ 571	\$ 678	\$ 1614
Bench 	Non-Channel		PSBN	\$ 4356	\$ 103	\$ 207	\$ 309	\$ 446	\$ 583	\$ 720	\$ 857	\$ 2039
	Channeled		PSBC	\$ 4779	\$ 103	\$ 207	\$ 309	\$ 446	\$ 583	\$ 720	\$ 857	\$ 2039
Armless Sofa 	Non-Channel		PSASN	\$ 5626	\$ 120	\$ 240	\$ 360	\$ 520	\$ 680	\$ 840	\$ 1000	\$ 2379
	Channeled		PSASC	\$ 6191	\$ 120	\$ 240	\$ 360	\$ 520	\$ 680	\$ 840	\$ 1000	\$ 2379
Double Arm Sofa 	Non-Channel	CLSNO	PSDSN	\$ 6897	\$ 120	\$ 240	\$ 360	\$ 520	\$ 680	\$ 840	\$ 1000	\$ 2379
	Channeled	CLSCNO	PSDSC	\$ 7460	\$ 120	\$ 240	\$ 360	\$ 520	\$ 680	\$ 840	\$ 1000	\$ 2379

*Old model numbers are no longer orderable. Please follow the new model numbers and the specification logic below.

*Bench is not recommended to be used as a modular piece with others due to seat pan angle difference.

<p>How to specify — Select the Model Number from above.</p> <p>P S .</p>	<p>1st Option: FSC Certified Wood: FSC Select for FSC Certified Wood</p> <p>F S C .</p>	<p>2nd Option: Select the Base Color: See page 269 for selections and Color Codes.</p> <p>P2 Add \$164 P3 Add \$246 P4 Add \$327</p> <p> .</p>	<p>3rd Option: Select the Upholstery: See page 268 for approved standard and partnership patterns. See pages 6-8 for COM/COL Guidelines.</p> <p> .</p>
---	--	--	--

Example: PSDSN.FSC.PJW.AI19

Model Number	COM Package			Overall			Seat			Armrests			Backrest				Unit Weight	Ship Weight Per Carton	Cubes
	Height	Width	Depth	Height	Width	Depth	Pan Angle (Range)	Armrest Height	Width Between Arms	Armrest Length	Height	Width	Lumbar Height	Backrest Seat Angle (Range)					
PSCN	4.5	30"	36"	29¼"	17"	24"	20½"	4.2	8½"	6"	21"	14½"	24"	9½"	102	71	95	35.4	
PSCC	4.5	30"	36"	29¼"	17"	24"	20½"	4.2	8½"	6"	21"	14½"	24"	9½"	102	71	95	35.4	
PSCPN	5.5	30"	40"	29¼"	17"	28"	20½"	4.2	8½"	6"	21"	14½"	28"	9½"	102	75	96	35.4	
PSCPC	5.5	30"	40"	29¼"	17"	28"	20½"	4.2	8½"	6"	21"	14½"	28"	9½"	102	75	96	35.4	
PSBN	5.5	17"	76"	29¼"	17"	76"	29¼"	0								75	125	37.1	
PSBC	5.5	17"	76"	29¼"	17"	76"	29¼"	0								75	125	37.1	
PSASN	7	30"	76"	29¼"	17"	76"	20½"	4.2				14½"	76"	9½"	102	100	160	69.5	
PSASC	7	30"	76"	29¼"	17"	76"	20½"	4.2				14½"	76"	9½"	102	100	160	69.5	
PSDSN	7	30"	76"	29¼"	17"	64"	20½"	4.2	8½"	6"	21"	14½"	64"	9½"	102	109	170	69.5	
PSDSC	7	30"	76"	29¼"	17"	64"	20½"	4.2	8½"	6"	21"	14½"	64"	9½"	102	109	170	69.5	

PARALLEL

(See page 321 for COM pricing on Grades 9-22)

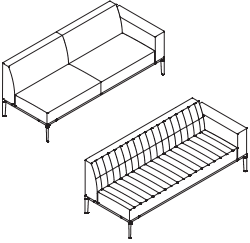
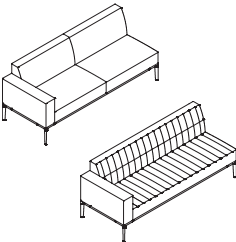
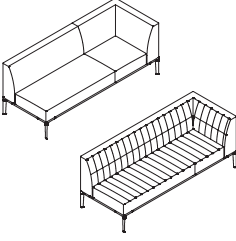
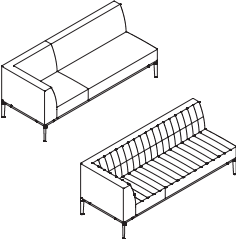
Description	Upholstery	Model Number		Base		Upcharge List Price – Add to Base Price						
		Old	New	List Price	2	3	4	5	6	7	8	L1 Leather
Left Arm Sofa *NOT for 90-degree turn 	Non-Channel		PSLSN	\$ 6050	\$ 120	\$ 240	\$ 360	\$ 520	\$ 680	\$ 840	\$ 1000	\$ 2379
	Channeled		PSLSC	\$ 6615	\$ 120	\$ 240	\$ 360	\$ 520	\$ 680	\$ 840	\$ 1000	\$ 2379
Right Arm Sofa *NOT for 90-degree turn 	Non-Channel		PSRSN	\$ 6050	\$ 120	\$ 240	\$ 360	\$ 520	\$ 680	\$ 840	\$ 1000	\$ 2379
	Channeled		PSRSC	\$ 6615	\$ 120	\$ 240	\$ 360	\$ 520	\$ 680	\$ 840	\$ 1000	\$ 2379
Left Sectional *Only for 90-degree turn 	Non-Channel		PSLCN	\$ 6615	\$ 120	\$ 240	\$ 360	\$ 520	\$ 680	\$ 840	\$ 1000	\$ 2379
	Channeled		PSLCC	\$ 7319	\$ 120	\$ 240	\$ 360	\$ 520	\$ 680	\$ 840	\$ 1000	\$ 2379
Right Sectional *Only for 90-degree turn 	Non-Channel		PSRCN	\$ 6615	\$ 120	\$ 240	\$ 360	\$ 520	\$ 680	\$ 840	\$ 1000	\$ 2379
	Channeled		PSRCC	\$ 7319	\$ 120	\$ 240	\$ 360	\$ 520	\$ 680	\$ 840	\$ 1000	\$ 2379

*Old model numbers are no longer orderable. Please follow the new model numbers and the specification logic below.

*Bench is not recommended to be used as a modular piece with others due to seat pan angle difference.

<p>How to specify — Select the Model Number from above.</p> <p>P S .</p>	<p>1st Option: FSC Certified Wood: FSC Select for FSC Certified Wood</p> <p>F S C .</p>	<p>2nd Option: Select the Base Color: See page 269 for selections and Color Codes.</p> <p>P2 Add \$164 P3 Add \$246 P4 Add \$327</p> <p> .</p>	<p>3rd Option: Select the Upholstery: See page 268 for approved standard and partnership patterns. See pages 6-8 for COM/COL Guidelines.</p> <p> </p>
---	--	--	--

Example: PLSLN.FSC.PJW.AI19

Model Number	Overall				Seat			Armrests			Backrest							
	COM Package	Height	Width	Depth	Height	Width	Depth	Pan Angle (Range)	Armrest Height	Width Between Arms	Armrest Length	Height	Width	Lumbar Height	Backrest Seat Angle (Range)	Unit Weight	Ship Weight Per Carton	Cubes
PSLSN	7	30"	76"	29¼"	17"	70"	20½"	4.2	8½"	6"	21"	14½"	70"	9½"	102	106	166	69.5
PSLSC	7	30"	76"	29¼"	17"	70"	20½"	4.2	8½"	6"	21"	14½"	70"	9½"	102	106	166	69.5
PSRSN	7	30"	76"	29¼"	17"	70"	20½"	4.2	8½"	6"	21"	14½"	70"	9½"	102	106	166	69.5
PSRSC	7	30"	76"	29¼"	17"	70"	20½"	4.2	8½"	6"	21"	14½"	70"	9½"	102	106	166	69.5
PSLCN	7	30"	76"	29¼"	17"	70"	20½"	4.2	8½"	6"	21"	14½"	70"	9½"	102	105	165	69.5
PSLCC	7	30"	76"	29¼"	17"	70"	20½"	4.2	8½"	6"	21"	14½"	70"	9½"	102	105	165	69.5
PSRCN	7	30"	76"	29¼"	17"	70"	20½"	4.2	8½"	6"	21"	14½"	70"	9½"	102	105	165	69.5
PSRCC	7	30"	76"	29¼"	17"	70"	20½"	4.2	8½"	6"	21"	14½"	70"	9½"	102	105	165	69.5

PARALLEL

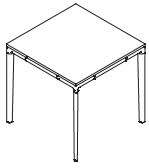

Description	Model Number		Unit Weight	Ship Weight	Cubes	Base		Upcharge List Price – Add to Base Price				
	Old	New				List Price	L2	L3	V2	V3	Solid B	Solid C
Side Table — 22"W x 22"D x 21½"H												
Laminate Flat Edge	PTSTL		39	49	13.7	\$ 1622	\$ 22	\$ 44				
Veneer Square Edge	PTSTV		37	47	13.7	\$ 2476			\$ 213	\$ 320		
Solid Surface	PTSTS		42	52	13.7	\$ 3244					\$ 66	\$ 131

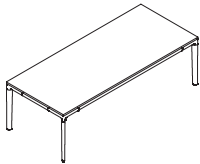

Coffee Table — 52"W x 22"D x 16"H												
Laminate Flat Edge	PTCTL		53	68	16.3	\$ 2081	\$ 33	\$ 66				
Veneer Square Edge	PTCTV		51	66	16.3	\$ 2794			\$ 240	\$ 360		
Solid Surface	PTCTS		77	92	16.3	\$ 4092					\$ 153	\$ 306

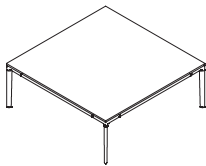

Coffee Table — 42"W x 42"D x 16"H												
Laminate Flat Edge	PTLTL		53	68	24.0	\$ 2187	\$ 39	\$ 77				
Veneer Square Edge	PTLTV		51	66	24.0	\$ 3049			\$ 262	\$ 393		
Solid Surface	PTLTS		111	126	24.0	\$ 4515					\$ 218	\$ 436

PARALLEL

<p>How to specify — Select the Model Number from above.</p>	<p>1st Option: Select the Base Color: See page 269 for selections and Color Codes. P2 Add \$88 Side Table 22" \$109 Coffee Table 52" \$120 Coffee Table 42" P3 Add \$131 Side Table 22" \$164 Coffee Table 52" \$180 Coffee Table 42" P4 Add \$175 Side Table 22" \$218 Coffee Table 52" \$240 Coffee Table 42"</p>	<p>2nd Option: Select the Laminate (if applicable): See page 269 for selections and Color Codes.</p>	<p>2nd Option: Select the Veneer (if applicable): See page 269 for selections and Finish Codes.</p>	<p>2nd Option: Select Solid Surface (if applicable): Grade A SFW3 Frosty White Grade B SDW4 Designer White Grade C SNS5 Night Stars Grade D SMC2 Masoned Concrete SMA1 Monte Amiata More Wilsonart and Corian colors available as specials</p>	<p>3rd Option: Select the Edge Color (Laminate only): See page 269 for selections and Color Codes.</p>	<p>4th Option: Veneer Finish Method (Veneer only): OP Open Pore Low Shin FF Full-Fill Cleartech Add \$218 Side Table \$218 Coffee Tables</p>
<p>P S . P . L . . S </p>						

Examples: PTSTL.P4Q.LDW1.DW PTCTV.PJW.SE800.OP PTLTS.POL.SDW4

BASE PAINT FINISHES

GRADE P1	
Textured Salt.....	P8Z
GRADE P2	
Solar Black.....	P8X

LAMINATES

GRADE L1	
SOLID COLORS	
Black.....	P
Brownstone.....	LM13
Bungalow.....	LM12
Designer White.....	LDW1
Flint.....	LM16
Fossil Shale.....	LEH1
Loft.....	LM11
Muslin.....	LM15
Titanium.....	LT11

ABSTRACT	
Ash.....	LT3B
Handspun Pearl.....	LAHP
Handspun Dove.....	LAHD
Handspun Slate.....	LAHS
Handspun Chestnut.....	LAHC
Silver Mesh.....	LT8D

WOODGRAIN	
Belair.....	LWBA
Bourbon Cherry.....	H
Field Elm.....	LWFE
Florence Walnut.....	LFW1
Kingswood Walnut.....	LK11
Natural Maple.....	LWD
NeoWalnut.....	LNU1
Pinnacle.....	PINC
Shaker Cherry.....	LW7C

GRADE L2	
Beigewood.....	LWBE
Fawn Cypress.....	LFC1
Lowell Ash.....	LLA1
Mangalore Mango.....	LMM1
Natural Recon.....	LNR1
Phantom Charcoal.....	LPC1
Phantom Ecu.....	LPE1
Portico Teak.....	LPT1
Skyline Walnut.....	LSW1
Veranda Teak.....	LVT1

GRADE L3	
Natural Walnut.....	LWNW

LAMINATE EDGE COLORS

Beigewood.....	DE
Belair.....	BA
Black.....	E4
Bourbon Cherry.....	H
Brownstone.....	EY
Bungalow.....	EX
Designer White.....	DW
Fawn Cypress.....	FC
Field Elm.....	FE
Flint.....	E9
Florence Walnut.....	FW
Fossil.....	EH
Kingswood Walnut.....	KI
Loft.....	EV
Lowell Ash.....	DL
Mangalore Mango.....	MM
Muslin.....	EU
Natural Maple.....	DD
Natural Recon.....	NR
Natural Walnut.....	DN
NeoWalnut.....	NU
Parchment.....	EN
Phantom Charcoal.....	PC
Phantom Ecu.....	PE
Pinnacle.....	PI
Platinum Metallic.....	EP
Portico Teak.....	DP
Shaker Cherry.....	DF
Skyline Walnut.....	SW
Titanium.....	TI
Veranda Teak.....	VT

STRATAWOOD VENEERS

GRADE V2	
CHERRY	
Cinnamon/Biltmore Cherry.....	SC260
Lowell Ash.....	SC394
Clear Cherry.....	SC700
Light Cherry.....	SC701
Shaker Cherry.....	SC774
Burnished Cherry.....	SC777

MAPLE	
Field Elm.....	SE599
Clear Maple***.....	SE800
Harvest Maple.....	SE856
Beigewood.....	SE878
Phantom Ecu.....	SE912
Belair.....	SE934

OAK	
Clear Oak.....	SE300
Dark Rift Cut Oak.....	SE331

SILVER OAK	
Silver Oak Clear.....	SB100
Portico Teak.....	SB150

WALNUT	
Florence Walnut.....	ST579
Light Walnut.....	ST601
Skyline Walnut.....	ST625
Pinnacle Walnut.....	ST679
Sumatra Walnut.....	ST693

NATURAL VENEERS — FLAT CUT

GRADE V2	
CHERRY	
Cinnamon/Biltmore Cherry.....	NC260
Lowell Ash.....	NC394
Medium Red Cherry.....	NC512
Light Cherry.....	NC701
Shaker Cherry.....	NC774
Burnished Cherry.....	NC777

MAPLE	
Clear Maple.....	NE800
Harvest Maple.....	NE856

WALNUT	
Ebony Walnut.....	NT509
Florence Walnut.....	NT579
Light Walnut.....	NT601
Skyline Walnut.....	NT625
Nutmeg Walnut.....	NT629
Pinnacle Walnut.....	NT679
Sumatra Walnut.....	NT693

NATURAL VENEERS — RIFT CUT

GRADE V3	
Fawn Cypress Rift Cut Oak.....	RF108
Light Rift Cut Oak.....	RF301
Dark Rift Cut Oak.....	RF331
Phantom Ecu Rift Cut Oak.....	RF912

NOTE: Refer to individual product pages for upcharges.

FSC Certified Wood at Allsteel
See page 459 for more information.

Two Thirds Standard Upholstery Selections by Model/Series.

Two Thirds



GRADE 1		
Apex	APX	•
Centurion	CU	•
Contourett	UR	•
Dapper	DAPR	•
Ensemble	ENSB	•
Hamilton <i>(De-emphasized)</i>	HAML	•
Inertia <i>(De-emphasized)</i>	NR	•
GRADE 2		
Appoint Seating	PNS	•
Blume	BLME	•
Clyde	CLYD	•
Dotty <i>(De-emphasized)</i>	DOT	•
Rush	RUSH	•
Spin	SPNN	•
Whisper Vinyl	WP	•
GRADE 3		
Lateral ⊕	SCFSLAT	•
Moxie	SX	•
Purl	PURL	•
Quill	QUL	•
GRADE 4		
Caper ⊕	SMHMCAP	•
Manner ⊕	SMHMMAN	•
Merit ⊕	SMHMMER	•
Messenger ⊕	SMHMGRM	•
Metric ⊕	SMHMMET	•
Mode ⊕	SMHMMOD	•
Murmur ⊕	SMHMMUR	•
Muse ⊕	SMHMMUS	•
Trundle ⊕	SMHMTRN	•
GRADE 5		
Main Line Flax ⊕	SCAMMLF	•

Two Thirds

GRADE 6		
Arris	ARR	•
Blazer ⊕	SCAMBLZ	•
Chock ⊕	SMHMCCK	•
Hemp ⊕	SCAMHMP	•
Pocket ⊕	SMHMPKT	•
Maharam Sequence ⊕	SMHMSQN	•
Tandem ⊕	SMHMTAN	•
GRADE 7		
Silk ⊕	SCAMSLK	•
GRADE 8		
Apt ⊕	SMHMAPT	•
Brisa ⊕	RS	•
Zap ⊕	SCAMZAP	•
GRADE 9		
Ultraleather Pro ⊕	SUF554	•
Yoredale ⊕	SCAMYDL	•
GRADE L1		
Davenport	DAV	•
Florence	FLOR	•
Strasburg	STB	•

⊕ Partnership Program — See page 10 for details.
 • Available upholstery option

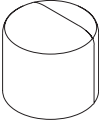
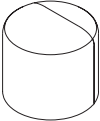
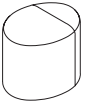
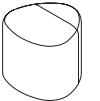
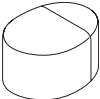
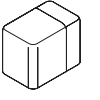
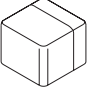
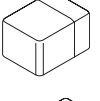

Description	Model Number	Upcharge List Price — Add to Base Price									
		Base List Price	2	3	4	5	6	7	8	L1 Leather	
Pouf Single Upholstery Models											
 18" Round Pouf	EPR18S	\$ 798	\$ 27	\$ 52	\$ 78	\$ 112	\$ 147	\$ 180	\$ 214	\$ 480	
 18" Round Wobble Pouf	EPW18S	\$ 871	\$ 27	\$ 52	\$ 78	\$ 112	\$ 147	\$ 180	\$ 214	\$ 480	
 17" x 22" Pebble Pouf	EPP1722S	\$ 1016	\$ 30	\$ 58	\$ 88	\$ 127	\$ 165	\$ 204	\$ 244	\$ 544	
 18" x 20" Pebble Pouf	EPP1820S	\$ 1092	\$ 28	\$ 55	\$ 82	\$ 119	\$ 155	\$ 192	\$ 229	\$ 512	
 21" x 28" Pebble Pouf	EPP2128S	\$ 1164	\$ 33	\$ 66	\$ 99	\$ 141	\$ 185	\$ 228	\$ 272	\$ 608	
 14" x 21" Block Pouf	EPB1421S	\$ 871	\$ 40	\$ 79	\$ 118	\$ 172	\$ 224	\$ 276	\$ 329	\$ 736	
 21" x 21" Block Pouf	EPB2121S	\$ 944	\$ 40	\$ 79	\$ 118	\$ 172	\$ 224	\$ 276	\$ 329	\$ 736	
 21" x 28" Block Pouf	EPB2128S	\$ 1016	\$ 51	\$ 100	\$ 150	\$ 215	\$ 282	\$ 348	\$ 415	\$ 928	
 21" x 42" Block Pouf	EPB2142S	\$ 1382	\$ 51	\$ 100	\$ 150	\$ 215	\$ 282	\$ 348	\$ 415	\$ 928	





TWO THIRDS

<p>How to specify — Select the Model Number from above.</p> <p>E P .</p>	<p>1st Option: FSC Certified Wood</p> <p>FSC Select for FSC Certified Wood</p> <p>F S C .</p>	<p>2nd Option: Select the Upholstery</p> <p>See page 279 for selections.</p> <p> .</p>	<p>3rd Option: Select Handle (if applicable):</p> <p>DAV01 Davenport Black DAV11 Davenport Cream DAV13 Davenport Camel</p> <p> .</p>
---	--	--	--

Example: EPB2128S.FSC.ARR07

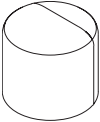
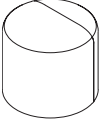
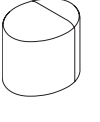
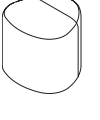
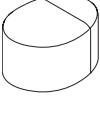
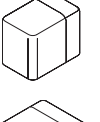
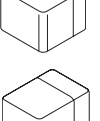
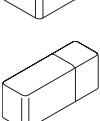
Model Number	Overall					
	Ship Weight	Cubes	COM Yardage*	Height	Width	Depth
EPR18S	11	5.4	1.6	17.25"	18.5"	18.5"
EPR18HS	15	5.4	1.6	17.25"	18.5"	18.5"
EPW18S	13	6.5	1.6	18.5"	18.5"	18.5"
EPW18HS	17	4.4	1.6	18.5"	18.5"	18.5"
EPP1722S	25	5.4	1.7	17.25"	22"	17"
EPP1722HS	25	5.4	1.7	17.25"	22"	17"
EPP1820S	28	6.0	1.7	19.5"	20"	18"
EPP1820HS	28	6.0	1.7	19.5"	20"	18"
EPP2128S	33	8.0	1.8	16.5"	28"	21"
EPP2128HS	33	8.0	1.8	16.5"	28"	21"
EPB1421S	21	5.4	1.7	17.25"	21"	14"
EPB1421HS	21	5.4	1.7	17.25"	21"	14"
EPB2121S	29	6.0	2.1	17.25"	21"	21"
EPB2121HS	29	6.0	2.1	17.25"	21"	21"
EPB2128S	37	8.0	2.3	17.25"	28"	21"
EPB2142S	50	12.0	2.9	17.25"	42"	21"

*COM Yardage is listed for total yardage/feet required for a model, with applicable yardage/feet for individual components listed.

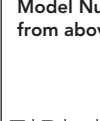
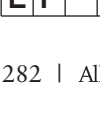
Description	Model Number	Base List Price	Upcharge List Price — Add to Base Price									
			2	3	4	5	6	7	8	L1 Leather		
Pouf Multi-Upholstery Models												
	18" Round Pouf	EPR18M	\$ 908	1/3 Upholstery	\$ 15	\$ 28	\$ 42	\$ 59	\$ 78	\$ 96	\$ 115	\$ 257
				2/3 Upholstery	\$ 22	\$ 45	\$ 67	\$ 98	\$ 127	\$ 156	\$ 186	\$ 416
	18" Round Pouf w/Handle	EPR18HM	\$ 1017									
	18" Round Wobble Pouf	EPW18M	\$ 980	1/3 Upholstery	\$ 15	\$ 28	\$ 42	\$ 59	\$ 78	\$ 96	\$ 115	\$ 257
				2/3 Upholstery	\$ 22	\$ 45	\$ 67	\$ 98	\$ 127	\$ 156	\$ 186	\$ 416
	18" Round Wobble Pouf w/Handle	EPW18HM	\$ 1089									
	17" x 22" Pebble Pouf	EPP1722M	\$ 1125	1/3 Upholstery	\$ 15	\$ 28	\$ 42	\$ 59	\$ 78	\$ 96	\$ 115	\$ 257
				2/3 Upholstery	\$ 27	\$ 52	\$ 78	\$ 112	\$ 147	\$ 180	\$ 214	\$ 480
	17" x 22" Pebble Pouf w/Handle	EPP1722HM	\$ 1234									
	18" x 20" Pebble Pouf	EPP1820M	\$ 1199	1/3 Upholstery	\$ 15	\$ 28	\$ 42	\$ 59	\$ 78	\$ 96	\$ 115	\$ 257
				2/3 Upholstery	\$ 27	\$ 52	\$ 78	\$ 112	\$ 147	\$ 180	\$ 214	\$ 480
	18" x 20" Pebble Pouf w/Handle	EPP1820HM	\$ 1308									
	21" x 28" Pebble Pouf	EPP2128M	\$ 1273	1/3 Upholstery	\$ 15	\$ 28	\$ 42	\$ 59	\$ 78	\$ 96	\$ 115	\$ 257
				2/3 Upholstery	\$ 27	\$ 52	\$ 78	\$ 112	\$ 147	\$ 180	\$ 214	\$ 480
	21" x 28" Pebble Pouf w/Handle	EPP2128HM	\$ 1382									
	14" x 21" Block Pouf	EPB1421M	\$ 980	1/3 Upholstery	\$ 18	\$ 34	\$ 52	\$ 75	\$ 98	\$ 120	\$ 143	\$ 320
				2/3 Upholstery	\$ 28	\$ 55	\$ 82	\$ 119	\$ 155	\$ 192	\$ 229	\$ 512
	14" x 21" Block Pouf w/Handle	EPB1421HM	\$ 1089									
	21" x 21" Block Pouf	EPB2121M	\$ 1052	1/3 Upholstery	\$ 18	\$ 34	\$ 52	\$ 75	\$ 98	\$ 120	\$ 143	\$ 320
				2/3 Upholstery	\$ 28	\$ 55	\$ 82	\$ 119	\$ 155	\$ 192	\$ 229	\$ 512
	21" x 21" Block Pouf w/Handle	EPB2121HM	\$ 1161									
	21" x 28" Block Pouf	EPB2128M	\$ 1125	1/3 Upholstery	\$ 18	\$ 34	\$ 52	\$ 75	\$ 98	\$ 120	\$ 143	\$ 320
				2/3 Upholstery	\$ 28	\$ 55	\$ 82	\$ 119	\$ 155	\$ 192	\$ 229	\$ 512
	14" x 42" Block Pouf	EPB1442M	\$ 1382	1/3 Upholstery	\$ 28	\$ 55	\$ 82	\$ 119	\$ 155	\$ 192	\$ 229	\$ 512
				2/3 Upholstery	\$ 40	\$ 79	\$ 118	\$ 172	\$ 224	\$ 276	\$ 329	\$ 736
	21" x 42" Block Pouf	EPB2142M	\$ 1491	1/3 Upholstery	\$ 28	\$ 55	\$ 82	\$ 119	\$ 155	\$ 192	\$ 229	\$ 512
				2/3 Upholstery	\$ 40	\$ 79	\$ 118	\$ 172	\$ 224	\$ 276	\$ 329	\$ 736

Multi-upholstery Pricing Example:	Model/Options	Base Price/Upcharges
Step 1: Select Model	EPB1421M	\$ 980
Step 2: Select 1/3 Upholstery	Grade 6 Arris	\$ 98 upcharge
Step 3: Select 2/3 Upholstery	Grade 3 Purl	\$ 55 upcharge
Add Base + applicable Upcharges for Total List Price =		\$ 1133



TWO THIRDS

<p>How to specify — Select the Model Number from above.</p> <p>E P .</p>	<p>1st Option: FSC Certified Wood (if applicable):</p> <p>FSC Select for FSC Certified Wood</p> <p>F I S C .</p>	<p>2nd Option: Select the 1/3 Upholstery:</p> <p>See page 279 for selections.</p> <p> </p>	<p>3rd Option: Select the 2/3 Upholstery:</p> <p>See page 279 for selections.</p> <p> </p>	<p>4th Option: Select Handle (if applicable):</p> <p>DAV01 Davenport Black DAV11 Davenport Cream DAV13 Davenport Camel</p> <p> </p>
---	---	---	---	--

Example: EPB2128M.FSC.QUL05.PURL11



Model Number					Overall		
		Ship Weight	Cubes	COM Yardage*	Height	Width	Depth
EPR18M		15	5.4		17.25"	18.5"	18.5"
EPR18HM		15	5.4		17.25"	18.5"	18.5"
	1/3 Upholstery			0.9			
	2/3 Upholstery			1.3			
EPW18M		17	6.5		18.5"	18.5"	18.5"
EPW18HM		17	6.5		18.5"	18.5"	18.5"
	1/3 Upholstery			0.9			
	2/3 Upholstery			1.3			
EPP1722M		25	5.4		17.25"	22"	17"
EPP1722HM		25	5.4		17.25"	22"	17"
	1/3 Upholstery			0.8			
	2/3 Upholstery			1.3			
EPP1820M		28	6.0		19.5"	20"	18"
EPP1820HM		28	6.0		19.5"	20"	18"
	1/3 Upholstery			0.9			
	2/3 Upholstery			1.4			
EPP2128M		33	8.0		16.5"	28"	21"
EPP2128HM		33	8.0		16.5"	28"	21"
	1/3 Upholstery			0.8			
	2/3 Upholstery			1.5			
EPB1421M		21	5.4		17.25"	21"	14"
EPB1421HM		21	5.4		17.25"	21"	14"
	1/3 Upholstery			0.9			
	2/3 Upholstery			1.4			
EPB2121M		33	6.0		17.25"	21"	21"
EPB2121HM		33	6.0		17.25"	21"	21"
	1/3 Upholstery			1.2			
	2/3 Upholstery			1.4			
EPB2128M		37	8.0		17.25"	28"	21"
	1/3 Upholstery			1.2			
	2/3 Upholstery			1.6			
EPB1442M		39	12.0		17.25"	42"	14"
	1/3 Upholstery			1.4			
	2/3 Upholstery			1.9			
EPB2142M		50	12.0		17.25"	42"	21"
	1/3 Upholstery			1.4			
	2/3 Upholstery			1.9			

*COM Yardage is listed for total yardage/feet required for a model, with applicable yardage/feet for individual components listed.

Description	Model Number	Base List Price	Upcharge List Price — Add to Base Price								P2 Paint	L1 Leather
			2	3	4	5	6	7	8			
Bench Single Upholstery Models												
 39" Round Bench	EB39S	\$ 2270	\$ 40	\$ 79	\$ 118	\$ 172	\$ 224	\$ 276	\$ 329	\$ 88	\$ 736	
 21" x 42" Bench	EB2142S	\$ 1818	\$ 28	\$ 55	\$ 82	\$ 119	\$ 155	\$ 192	\$ 229	\$ 71	\$ 512	
 42" x 42" Bench	EB4242S	\$ 2270	\$ 48	\$ 96	\$ 144	\$ 209	\$ 272	\$ 336	\$ 401	\$ 88	\$ 895	

<p>How to specify — Select the Model Number from above.</p> <p>EB .</p>	<p>1st Option: FSC Certified Wood FSC Select for FSC Certified Wood</p> <p>F S C .</p>	<p>2nd Option: Select the Upholstery See page 279 for selections.</p> <p> </p>	<p>3rd Option: Select the Paint P8Z Textured Salt P8X Solar Black (add P2 Paint upcharge)</p> <p> </p>
--	---	---	---

Example: EB39S.FSC.ARR.P8Z

Description	Model Number	Base List Price	Upcharge List Price — Add to Base Price								P2 Paint	L1 Leather
			2	3	4	5	6	7	8			
Bench Multi-Upholstery Models												
 39" Round Bench	EB39M	\$ 2418	1/3 Upholstery	\$ 24	\$ 48	\$ 72	\$ 104	\$ 137	\$ 168	\$ 200	\$ 88	\$ 448
			2/3 Upholstery	\$ 31	\$ 63	\$ 93	\$ 135	\$ 175	\$ 216	\$ 258	\$ 576	
 21" x 42" Bench	EB2142M	\$ 1964	1/3 Upholstery	\$ 21	\$ 42	\$ 63	\$ 90	\$ 117	\$ 144	\$ 172	\$ 71	\$ 384
			2/3 Upholstery	\$ 24	\$ 48	\$ 72	\$ 104	\$ 137	\$ 168	\$ 200	\$ 448	
 42" x 42" Bench	EB4242M	\$ 2418	1/3 Upholstery	\$ 39	\$ 76	\$ 114	\$ 164	\$ 214	\$ 264	\$ 314	\$ 88	\$ 704
			2/3 Upholstery	\$ 42	\$ 82	\$ 124	\$ 178	\$ 234	\$ 288	\$ 343	\$ 768	

Multi-upholstery Pricing Example:	Model/Options	Base Price/Upcharges
Step 1: Select Model	EB4242M	\$ 2418
Step 2: Select 1/3 Upholstery	Grade 6 Arris	\$ 214 upcharge
Step 3: Select 2/3 Upholstery	Grade 4 Mode	\$ 124 upcharge
Step 4: Select Paint	Grade 2 P8X	\$ 88 upcharge
Add Base + applicable Upcharges for Total List Price =		\$ 2844

<p>How to specify — Select the Model Number from above.</p> <p>EB .</p>	<p>1st Option: FSC Certified Wood (if applicable): FSC Select for FSC Certified Wood</p> <p>F S C .</p>	<p>2nd Option: Select the 1/3 Upholstery See page 279 for selections.</p> <p> </p>	<p>3rd Option: Select the 2/3 Upholstery See page 279 for selections.</p> <p> </p>	<p>4th Option: Select the Paint P8Z Textured Salt P8X Solar Black (add P2 Paint upcharge)</p> <p> </p>
--	--	---	---	---

Example: EB4242M.FSC.ARR.MOD.P8X

TWO THIRDS

Model Number	Overall					
	Ship Weight	Cubes	COM Yardage*	Height	Width	Depth
EB39S	36	21.0	2.7	17.25"	39"	39"
EB2142S	33	10.3	1.9	17.25"	42"	21"
EB4242S	47	21.2	3.2	17.25"	42"	42"

*COM Yardage is listed for total yardage/feet required for a model, with applicable yardage/feet for individual components listed.

Model Number	Overall					
	Ship Weight	Cubes	COM Yardage*	Height	Width	Depth
EB39M		36	21.0	17.25"	39"	39"
	1/3 Upholstery			1.5		
	2/3 Upholstery			1.8		
EB2142M		33	10.3	17.25"	42"	21"
	1/3 Upholstery			0.9		
	2/3 Upholstery			1.1		
EB4242M		47	21.2	17.25"	42"	42"
	1/3 Upholstery			1.7		
	2/3 Upholstery			1.7		

*COM Yardage is listed for total yardage/feet required for a model, with applicable yardage/feet for individual components listed.

TWO THIRDS

Description	Model Number	Base List Price	Upcharge List Price — Add to Base Price		P2 Paint
			L2	L3	
Laminate Tables					
 20" Round Side Table	ET20	\$ 940	\$ 12	\$ 23	\$ 46
 39" Round Table	ET39	\$ 2114	\$ 32	\$ 62	\$ 91
 14" x 21" Side Table	ET1421	\$ 1331	\$ 18	\$ 34	\$ 62
 21" x 42" Table	ET2142	\$ 1804	\$ 29	\$ 57	\$ 74
 42" x 42" Table	ET4242	\$ 2195	\$ 34	\$ 68	\$ 91

Table Pricing Example:	Model/Options	Base Price/Upcharges
Step 1: Select Model	ET1421	\$ 1331
Step 2: Select Laminate	LWBA Belair	\$ 0 upcharge
Step 3: Select Edgeband	BA Belair	\$ 0 upcharge
Step 4: Select Paint	P8X Solar Black	\$ 62 upcharge
Add Base + applicable Upcharges for Total List Price =		\$ 1393

TWO THIRDS

<p>How to specify — Select the Model Number from above.</p> <p>E T .</p>	<p>1st Option: FSC Certified Wood (if applicable):</p> <p>FSC Select for FSC Certified Wood</p> <p>F S C .</p>	<p>2nd Option: Select the Laminate</p> <p>See page 278 for options.</p> <p> .</p>	<p>3rd Option: Select the Edge Band</p> <p>See page 278 for options.</p> <p> .</p>	<p>4th Option: Select the Paint</p> <p>P8Z Textured Salt P8X Solar Black (add P2 Paint upcharge)</p> <p> .</p>
---	---	---	--	--

Example: ET39.FSC.LWBA.BA.P8X

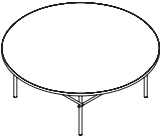
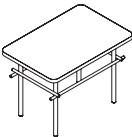
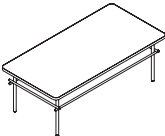
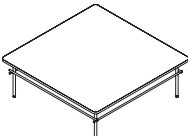
Model Number	Overall				
	Ship Weight	Cubes	Height	Width	Depth
ET20	14	3.4	17.25"	20"	20"
ET39	38	19.4	15"	39"	39"
ET1421	14	3.4	17.25"	21"	14"
ET2142	35	9.1	15"	42"	21"
ET4242	53	18.8	15"	42"	21"

TWO THIRDS

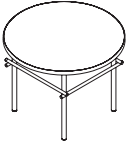
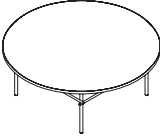
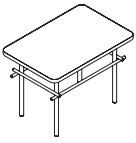
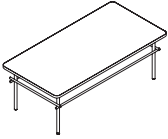
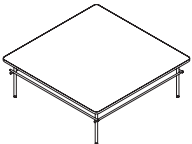
	Description	Model Number	Base List Price	Upcharge List Price — Add to Base Price		P2 Paint
				V2	V3	
	Veneer Tables 20" Round Side Table	EV20	\$ 1455	\$ 146	\$ 291	\$ 46
	39" Round Table	EV39	\$ 2376	\$ 238	\$ 476	\$ 91
	14" x 21" Veneer Side Table	EV1421	\$ 1667	\$ 167	\$ 334	\$ 62
	21" x 42" Veneer Table	EV2142	\$ 2003	\$ 201	\$ 401	\$ 74
	42" x 42" Veneer Table	EV4242	\$ 2463	\$ 247	\$ 493	\$ 91

TWO THIRDS

<p>How to specify — Select the Model Number from above.</p> <p>EV .</p>	<p>1st Option: FSC Certified Wood (if applicable): FSC Select for FSC Certified Wood</p> <p>F S C .</p>	<p>2nd Option: Select the Veneer See page 278 for options.</p> <p> .</p>	<p>3rd Option: Select the Veneer Finish OP Open Pore Low Sheen FF Full Fill Cleartech (add \$225)</p> <p> .</p>	<p>4th Option: Select the Paint P8Z Textured Salt P8X Solar Black (add P2 Paint upcharge)</p> <p> </p>
--	--	--	---	---

Example: EV39.FSC.NC701.FF.P8X

Model Number	Overall				
	Ship Weight	Cubes	Height	Width	Depth
EV20	22	3.4	17.25"	20"	20"
EV39	53	19.4	15"	39"	39"
EV1421	22	3.4	17.25"	21"	14"
EV2142	45	9.1	15"	42"	21"
EV4242	65	18.8	15"	42"	21"

TWO THIRDS

Social Collaborative Standard Upholstery Selections by Model/Series, for all other seating see pages 13-14.

Vicinity Lounge & Rocker

Vicinity Lounge & Rocker

LEATHER L1

Allsteel Leather	WTH	•
Florence Leather	FLOR	•

GRADE 1

Apex	APX	
Centurion	CU	•
Contourett	UR	•
Dapper	DAPR	
Hamilton <i>(De-emphasized)</i>	HAM	•
Inertia <i>(De-emphasized)</i>	NR	•
Optic <i>(De-emphasized)</i>	OP	

GRADE 2

Appoint Seating	PNS	•
Blume	BLME	
Clyde	CLYD	•
Dotty <i>(De-emphasized)</i>	DOT	•
Meld ⊕	SMHMMLD	•
Rush	RUSH	•
Spin Seating	SPNN	
Whisper Vinyl	WP	•

GRADE 3

Lateral ⊕	SCFSLAT	•
Moxie	SX	•
Purl	PURL	•
Quill	QUL	•

GRADE 4

Caper ⊕	SMHMCAP	•
Manner ⊕	SMHMMAN	•
Merit ⊕	SMHMMER	•
Messenger ⊕	SMHMGRM	•
Metric ⊕	SMHMMET	•
Mode ⊕	SMHMMOD	•
Multiply ⊕	SMHMMLT	•
Murmur ⊕	SMHMMUR	
Muse ⊕	SMHMMUS	
Trundle ⊕	SMHMTRN	•

GRADE 5

Main Line Flax ⊕	SCAMMLF	•
Rove ⊕	SMHMROV	•

GRADE 6

Arris	ARR	•
Blazer	SCAMBLZ	•
Chock ⊕	SMHMCKK	
Hedge ⊕	SMHMHEd	•
Pocket ⊕	SMHMpKT	•
Sequence ⊕	SMHMSQN	
Tandem ⊕	SMHMTAN	
Verse ⊕	SCARVRS	•

GRADE 8

Apt ⊕	SMHMAPT	•
Brisa ⊕	RS	•

GRADE 9

Ultraleather Pro ⊕	SUF554	•
--------------------	--------	---

GRADE 11

Fusion ⊕	SCARFUS	•
----------	---------	---

GRADE 13

Maze ⊕	SCARMZE	•
--------	---------	---

GRADE 14

Chroma ⊕	SCARCHR	•
----------	---------	---

⊕ Partnership Program — See page 10 for details.

≠ Upholstery will be Railroad cut.

• Available upholstery option

ROCKER PAINT FINISHES

GRADE P1

Black P71
 Designer White..... PJW
 Flint P02

GRADE P2

Pyrite.....PJE
 Silver.....PR6

LOUNGE PAINT FINISHES

GRADE P1

Black P71
 Designer White..... PJW
 Flint P02

GRADE P2

Pyrite.....PJE
 Silver.....PR6

GRADE P3

Bullseye.....PJF

GRADE P4

Polished Chrome.....POL

VENEER FINISHES

GRADE 2

Black Wash BeechRB997
 Natural BeechRB900
 White Wash BeechRB912

GRADE 3

Natural Oak..... NF302
 Warm Brown Oak..... NF394
 Grey Wash Oak NF314
 Natural Walnut.....QT500

NOTE: Refer to individual product pages for upcharges.

(See page 322 for COM pricing on Grades 9-22)

Description	Type	Model Number	List Price									
			1	2	3	4	5	6	7	8	L1	
Lounge Armless Sled Base	Fully Upholstered Back	CLG-UGANO	\$ 2509	\$ 2558	\$ 2606	\$ 2656	\$ 2720	\$ 2786	\$ 2850	\$ 2915	\$ 3447	
	Fully Upholstered Back w/Contrasting Welts	CLG-CGANO	\$ 2671	\$ 2753	\$ 2833	\$ 2915	\$ 3024	\$ 3131	\$ 3240	\$ 3348	\$ 4234	
	Upholstered with Veneer Back	CLG-WGANO	\$ 3519	\$ 3551	\$ 3584	\$ 3616	\$ 3661	\$ 3703	\$ 3747	\$ 3789	\$ 4145	



Model Number	Overall			Seat				Backrest				Shipping				
	COM Yardage	COL Sq. Feet	Height (Range)	Width	Depth	Height	Width	Depth	Rear Angle	Height	Width	Lumbar Height	Backrest/Seat Angle (Range)	Ship Weight Per Chair	Ship Weight Per Carton	Cubes
CLG-UGANO	3.0	50	27 1/4"	31 1/4"	28 3/4"	17 1/2"	26 1/2"	18 1/2"	13.9°	18 1/4"	21 1/4"	7"	97.7°	42	42	18.5
CLG-CGANO	5.0	50	27 1/4"	31 1/4"	28 3/4"	17 1/2"	26 1/2"	18 1/2"	13.9°	18 1/4"	21 1/4"	7"	97.7°	42	42	18.5
CLG-WGANO	2.0	45	27 1/4"	31 1/4"	28 3/4"	17 1/2"	26 1/2"	18 1/2"	13.9°	18 1/4"	21 1/4"	7"	97.7°	48	48	18.5

Note: Dimensions are in accordance with BIFMA G1-2002 guidelines — see illustration of guidelines on page 45.

<p>How to specify — Select the Model Number from above.</p>	<p>1st Option: Select the Glide: 0 Polycarbonate</p>	<p>2nd Option: Select the Frame Finish:</p> <p>P71 Black PJF Bullseye PJW Designer White POL Chrome P02 Flint PJE Pyrite PR6 Silver</p>	<p>3rd Option: Select the Veneer Shell Finish (if applicable):</p> <p>RB997 Black Wash Beech RB900 Natural Beech RB912 White Wash Beech NF314 Grey Wash Oak (add \$169) NF302 Natural Oak (add \$169) NF394 Warm Brown Oak (add \$169) QT500 Natural Walnut (add \$169)</p>
	<p>C L G - . 0 .</p>	<p>P .</p>	<p> </p>

Continued below ▼

<p>4th Option: Select the Upholstery:</p>	<p>5th Option: Select the Welt Cord Upholstery (if applicable):</p>
<p> .</p>	<p> .</p>

Examples: CLG-UGANO.0.POL.CU63 CLG-CGANO.0.P71.CU27.CU10 CLG-WGANO.0.P71.RB997.CU27

(See page 322 for COM pricing on Grades 9-22)

Description	Type	Model Number	List Price								
			1	2	3	4	5	6	7	8	L1
Lounge Armless	Fully Upholstered Back	CLR-UGANO	\$ 3108	\$ 3157	\$ 3205	\$ 3255	\$ 3319	\$ 3385	\$ 3449	\$ 3514	\$ 4046
Rocker Base	Fully Upholstered Back w/Contrasting Welts	CLR-CGANO	\$ 3262	\$ 3344	\$ 3424	\$ 3506	\$ 3615	\$ 3722	\$ 3831	\$ 3939	\$ 4825
	Upholstered with Veneer Back	CLR-WGANO	\$ 3701	\$ 3733	\$ 3766	\$ 3798	\$ 3843	\$ 3885	\$ 3929	\$ 3971	\$ 4327

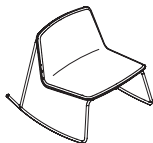

Model Number	COM Yardage		Overall			Seat			Backrest			Ship Weight Per Chair	Ship Weight Per Carton	Ctbs	
	COM	Sq. Feet	Height (Range)	Width	Depth	Height	Width	Depth	Height	Width	Lumbar Height				Backrest Seat Angle (Range)
CLR-UGANO	3.0	50	27 1/8"	31 1/4"	34 1/4"	17 1/8"	26 1/2"	18 1/2"	18 1/4"	21 1/8"	7"	97.7°	44	44	22.7
CLR-CGANO	5.0	50	27 1/8"	31 1/4"	34 1/4"	17 1/8"	26 1/2"	18 1/2"	18 1/4"	21 1/8"	7"	97.7°	44	44	22.7
CLR-WGANO	2.0	45	27 1/8"	31 1/4"	34 1/4"	17 1/8"	26 1/2"	18 1/2"	18 1/4"	21 1/8"	7"	97.7°	50	50	22.7

Note: Dimensions are in accordance with BIFMA G1-2002 guidelines — see illustration of guidelines on page 45.

<p>How to specify — Select the Model Number from above.</p> <p>CL R - . P .</p>	<p>1st Option: Select the Frame Finish:</p> <p>P71 Black P JW Designer White P02 Flint P JE Pyrite P R6 Silver</p>	<p>2nd Option: Select the Veneer Shell Finish (if applicable):</p> <p>RB997 Black Wash Beech RB900 Natural Beech RB912 White Wash Beech NF314 Grey Wash Oak (add \$169) NF302 Natural Oak (add \$169) NF394 Warm Brown Oak (add \$169) QT500 Natural Walnut (add \$169)</p>
---	---	--

Continued below ▼

<p>3rd Option: Select the Upholstery:</p> <p> .</p>	<p>4th Option: Select the Welt Cord Upholstery (if applicable):</p> <p> .</p>
---	---

Examples: CLR-UGANO.P71.CU63 CLR-CGANO.P JW.CU27.CU10 CLR-WGANO.P02.RB997.CU27



Allsteel Seating Upholstery Selections by Model/Series.

GRADE 1		
Centurion	CU	•
Dapper	DAPR	•
Ensemble	ENSB	•
Hamilton (<i>De-emphasized</i>)	HAML	•
Inertia (<i>De-emphasized</i>)	NR	•
GRADE 2		
Appoint Seating	PNS	•
Blume	BLME	•
Clyde	CLYD	•
Dotty (<i>De-emphasized</i>)	DOT	•
Rush	RUSH	•
GRADE 3		
Purl	PURL	•
Quill	QUL	•
GRADE 4		
Manner ⚡	SMHMMAN	•
Messenger ⚡	SMHMGRM	•
GRADE 5		
Main Line Flax ⚡	SCAMMLF	•
GRADE 6		
Arris	ARR	•
Blazer ⚡	SCAMBLZ	•
Hemp ⚡	SCAMHMP	•
Pocket ⚡	SMHMPKT	•
Sequence ⚡	SMHMSQN	•
GRADE 7		
Silk ⚡	SCAMSLK	•
GRADE 8		
Nimble ⚡	SCFSNIM	•
Zap ⚡	SCAMZAP	•
GRADE 9		
Yoredale ⚡	SCAMYDL	•

⚡ Partnership Program — See page 10 for details.
 • Available upholstery option

- Allsteel fabrics and foam meet requirements for CTB117.
- Contact Allsteel Customer Support for other flammability code approvals.

(See page 322 for COM pricing on Grades 9-22)

Description	Model Number <i>Add options below</i>	Base Price	Upholstery	Upcharge									
				2	3	4	5	6	7	8	9	10	
Co Ho Seating Co Ho Uph Lounge Chair	CHULNO	\$ 1758	Seat/Body	\$ 23	\$ 46	\$ 68	\$ 98	\$ 129	\$ 159	\$ 190	\$ 220	\$ 250	



Pricing Example:	Model/Options	Base Price/Upcharges
Step 1: Select Model	CHULNO	\$ 1758
Step 2: Select Arm	Tablet Arm with Designer White Laminate	\$ 450 upcharge
Step 3: Select Upholstery	Grade 3	\$ 46 upcharge
Add Base + applicable Upcharges for Total List Price =		\$ 2254

Model Number	Overall			Seat			Arms			Backrest								
	Ship Weight	Cubes	COM Yardage*	Width	Depth	Height	Width	Depth	Pan Angle (Range)	Armrest Height	Arm Pad Length	Arm Pad Width	Height	Width	Lumbar Height	Backrest Inclination from Vertical	Backrest/Seat Angle (Range)	
CHULNO	30	13½"	1.4	32½"	23" w/o Tablet Arm 36" w/Tablet Arm	29"	16¼"	22"	18"	5°	11½"	19"	9½"	19½"	20"	N/A	17°	102°

*COM Yardage is listed for total yardage/feet required for a model, with applicable yardage/feet for individual components listed.

<p>How to specify — Select the Model Number from above.</p>	<p>1st Option: Select Arm Option: N None LDW1 Tablet Arm with Designer White Laminate (add \$450 upcharge) LM11 Tablet Arm with Loft Laminate (add \$450 upcharge)</p>	<p>2nd Option: Select the Upholstery: See page 294 for selections and Color Codes.</p>
CHULNO

Example: CHULNO.LDW1.ISN002

Social Collaborative Standard Upholstery Selections by Model/Series, for all other seating see pages 13-14.

LINGER

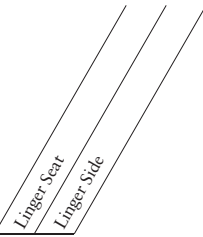

LEATHER L1			
Allsteel Leather	WTH		
Florence Leather	FLOR		

GRADE 1			
Apex	APX	•	•
Centurion	CU	•	•
Contourett	UR	•	•
Dapper	DAPR		•
Hamilton <i>(De-emphasized)</i>	HAM		•
Inertia <i>(De-emphasized)</i>	NR	•	•
Optic <i>(De-emphasized)</i>	OP		•

GRADE 2			
Appoint Seating	PNS	•	•
Blume	BLME	•	•
Clyde	CLYD	•	•
Dotty <i>(De-emphasized)</i>	DOT	•	•
Meld ⚡	SMHMMLD	•	•
Rush	RUSH		•
Spin Seating	SPNN		•
Whisper Vinyl	WP	•	•

GRADE 3			
Lateral ⚡	SCFSLAT		•
Moxie	SX	•	•
Purl	PURL	•	•
Quill	QUL	•	•

GRADE 4			
Caper ⚡	SMHMCAP	•	•
Manner ⚡	SMHMMAN	•	•
Merit ⚡	SMHMMER		•
Messenger ⚡	SMHMGRM	•	•
Metric ⚡	SMHMMET	•	•
Mode ⚡	SMHMMOD	•	•
Multiply ⚡	SMHMMLT		•
Murmur ⚡	SMHMMUR		•
Muse ⚡	SMHMMUS		•
Trundle ⚡	SMHMTRN		•

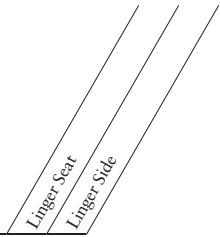

GRADE 5			
Main Line Flax ⚡	SCAMMLF		•
Rove ⚡	SMHMROV		•

GRADE 6			
Arris	ARR	•	•
Blazer	SCAMBLZ		•
Chock ⚡	SMHMCKK		•
Hedge ⚡	SMHMHED	•	•
Pocket ⚡	SMHMPKT		•
Sequence ⚡	SMHMSQN		•
Tandem ⚡	SMHMTAN		•
Verse ⚡	SCARVRS	•	•

GRADE 8			
Apt ⚡	SMHMAPT	•	•
Brisa ⚡	RS	•	•

GRADE 9			
Ultraleather Pro ⚡	SUF554	•	•

GRADE 11			
Fusion ⚡	SCARFUS	•	•

GRADE 13			
Maze ⚡	SCARMZE	•	•

GRADE 14			
Chroma ⚡	SCARCHR		•

⚡ Partnership Program — See page 10 for details.

≠ Upholstery will be Railroad cut.

• Available upholstery option

BASE PAINT FINISHES

GRADE 4

Polished AluminumPAL/P



NOTE: Refer to individual product pages for upcharges.

FSC Certified Wood at Allsteel
See page 459 for more information.

Linger is a lounge chair that accommodates a variety of postures. Take a seat for longer meetings, sit upright, lounge, or swing your legs over the side. Perch on the back for shorter interactions when you don't want to commit to the sit.

MODELS AND OPTIONS

Linger is available in one size with an upholstered seat and a base that can be painted or polished aluminum. Linger is available in solid or two-tone upholstery options.

APPLICATION

Place Linger in open areas, public or neighborhood spaces, small conference rooms, dedicated collaboration rooms, dormitory lounges, libraries, or hospitality waiting areas.

KEY FEATURES

Linger is constructed of upholstery over frame and foam with either a painted or polished aluminum base. The core is upholstery-grade FSC plywood with box joint and corner block construction. The base swivels so you can engage the whole room. Plus it self-centers to its original position when not in use to keep spaces ready for the next meeting. Upholster the seat and sides in two different fabrics to create a unique aesthetic. Linger accommodates multiple postures, including the ability to sit on the back ledge.

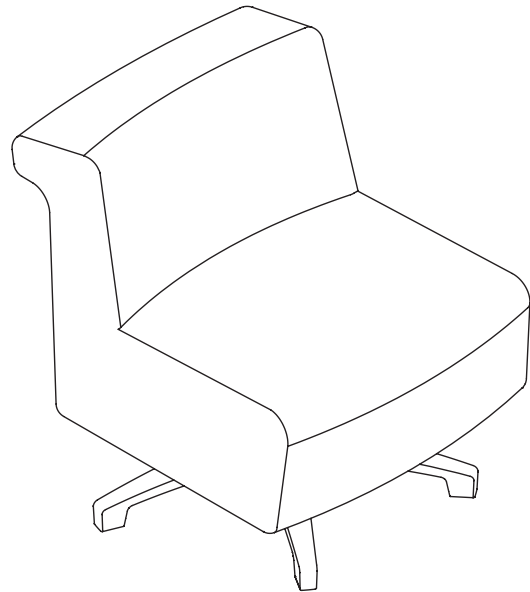

MATERIALS AND FINISHES

Linger has a fully upholstered seat that can be specified as a single upholstery or two-tone.

- All upholstery foams are CFC-free.
- All COMs must be approved for upholsterability or applicable fire code compliance prior to order entry. See pages 6-8 for COM ordering instructions.
- **Flammability** code compliance of Allsteel textiles and seating is listed on pages 17-19. COM/COL manufacturers supply certificates of compliance for fabric-only tests such as CAL TB117-2013.

Linger is warranted for users up to 300 lbs.

OPTIONS — LINGER

Base Color:

PAL Polished Aluminum

FSC Certified Wood:

FSC FSC Certified Wood

Upholstery:

See pages 17-19 for upholstery selections.

See page 296 for colors and codes.

(See page 322 for COM pricing on Grades 9-22)

Description	Base Option	Model Number	List Price							
			1	2	3	4	5	6	7	8
Linger	Polished	S924SS	\$ 3453	\$ 3514	\$ 3575	\$ 3636	\$ 3717	\$ 3799	\$ 3880	\$ 3960

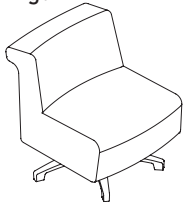

(See page 322 for COM upcharge pricing on Grades 9-22)

Description	Base Option	Model Number	Upcharge							
			1	2	3	4	5	6	7	8
Two-tone Linger	Polished	S924ST	\$ 3756	—	—	—	—	—	—	—
		Seat Upholstery – add to base price	\$ 0	\$ 42	\$ 82	\$ 122	\$ 177	\$ 230	\$ 285	\$ 339
		Side Upholstery – add to base price	\$ 0	\$ 21	\$ 42	\$ 61	\$ 89	\$ 116	\$ 143	\$ 169

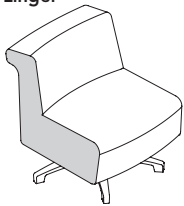

Two-tone Pricing Example:		Model/Options	Base Price / Upcharges
Step 1: Select Model		S924ST	\$ 3756
Step 2: Select Seat Upholstery		Grade 2 Trisect Marine	\$ 42 upcharge
Step 3: Select Side Upholstery		Grade 1 Whisper Vinyl Bone	\$ 0 upcharge
Add Base + applicable Upcharges for Total List Price =			\$ 3798

Model Number	Overall			Seat			Cubbs			
	COM Yachage	COL Sp. Feet	Height (Range)	Width	Depth	Height (Range)		Width	Depth (Range)	Slip Weight
S924SS	3.75	63¼	30½"	29"	27½"	17¼"	27"	23¼"	52	27.6
S924ST	3.75	63¼	30½"	29"	27½"	17¼"	27"	23¼"	52	27.6
Seat	2.5	42½								
Side	1.25	21¼								

<p>How to specify — Select the Model Number from above.</p>	<p>1st Option: Select the Base Finish: PAL Polished Aluminum</p>	<p>2nd Option: FSC Certified Wood: FSC Select for FSC Certified Wood</p>	<p>3rd Option: Select the Upholstery: See page 296 for selections and pages 17-19 for colors and codes.</p>	<p>4th Option: Select the Side Upholstery for Two-tone models (if applicable): See page 296 for selections and pages 17-19 for colors and codes.</p>
S 9 2 4 .	P A L .	F S C .	.	.

Example: S924SS.PAL.FSC.STX17

Social Collaborative Standard Upholstery Selections by Model/Series, for all other seating see pages 13-14.

REFLECT

Reflect Shell ≠
Reflect Seat & Back

LEATHER L1			
Allsteel Leather	WTH		
Florence Leather	FLOR		

GRADE 1			
Apex	APX		•
Centurion	CU	•	•
Contourett	UR		•
Dapper	DAPR	•	•
Hamilton <i>(De-emphasized)</i>	HAM	•	•
Inertia <i>(De-emphasized)</i>	NR	•	•
Optic <i>(De-emphasized)</i>	OP		

GRADE 2			
Appoint Seating	PNS		•
Blume	BLME		•
Clyde	CLYD	•	•
Dotty <i>(De-emphasized)</i>	DOT	•	•
Meld ⊕	SMHMMLD	•	•
Rush	RUSH	•	•
Spin Seating	SPNN		•
Whisper Vinyl	WP	•	•

GRADE 3			
Lateral ⊕	SCFSLAT		•
Moxie	SX	•	•
Purl	PURL	•	•
Quill	QUL		•

GRADE 4			
Caper ⊕	SMHMCAP	•	•
Manner ⊕	SMHMMAN	•	•
Merit ⊕	SMHMMER		•
Messenger ⊕	SMHMGRM	•	•
Metric ⊕	SMHMMET	•	•
Mode ⊕	SMHMMOD	•	•
Multiply ⊕	SMHMMLT		•
Murmur ⊕	SMHMMUR		
Muse ⊕	SMHMMUS		
Trundle ⊕	SMHMTRN		•

Reflect Shell ≠
Reflect Seat & Back

GRADE 5			
Main Line Flax ⊕	SCAMMLF		•
Rove ⊕	SMHMROV		•

GRADE 6			
Arris	ARR		•
Blazer	SCAMBLZ	•	•
Chock ⊕	SMHMCKK		
Hedge ⊕	SMHMHED	•	•
Pocket ⊕	SMHMPKT	•	•
Sequence ⊕	SMHMSQN		
Tandem ⊕	SMHMTAN		
Verse ⊕	SCARVRS	•	•

GRADE 8			
Apt ⊕	SMHMAPT		•
Brisa ⊕	RS		•

GRADE 9			
Ultraleather Pro ⊕	SUF554	•	•

GRADE 11			
Fusion ⊕	SCARFUS	•	•

GRADE 13			
Maze ⊕	SCARMZE	•	•

GRADE 14			
Chroma ⊕	SCARCHR		•

⊕ Partnership Program — See page 10 for details.

≠ Upholstery will be Railroad cut.

• Available upholstery option

VENEER FINISH

Light Cherry.....	SC701
Burnished Cherry	SC777
Field Elm Maple.....	SE599
Clear Maple	SE800
Harvest Maple	SE856
Phantom Ecrú Maple	SE912
Belair Maple.....	SE943
Clear Oak	SF300
Dark Rift Cut Oak.....	SF331

REFLECT

NOTE: Refer to individual product pages for upcharges.

FSC Certified Wood at Allsteel
See page [459](#) for more information.

Reflect creates personal refuges around the open office — in the hallway, adjacent to a row of workstations, or near a wall of windows. Enjoy the privacy of a large, sound-stifling back that reduces distractions and communicates unavailability. Or the generous space formed from wide armrests and an oversized seat, allowing room for your laptop, paperwork, and other tools of the trade. And the comfort of padded upholstery, which cushions you as you finish that email, report, or video call.

With Reflect, going solo doesn't always mean you have to go at it alone. Arrange multiple seats into pairs or pods to give team members a new space to collaborate. Use the concealed swivel to move towards or away from others as needed.

Some time away is good for everyone. Focus your attention in the right place with Reflect.

MODELS AND OPTIONS

Reflect is available with an upholstered seat/back and upper shell. Lower shells are veneer and each unit ships with a steel base plate for stationary placement.

APPLICATION

Place Reflect in open areas, public or neighborhood spaces, adjacent to workstations or in a cafe-type setting.

KEY FEATURES

Surprising Functionality

With an integrated swivel-based mechanism, Reflect enables multiple work modes — from 1:1 conversation to private office focus.

Communicated Privacy

Sight-blocking and sound dampening upper shell visually communicates unavailability and creates private seclusion.

Comfortable Yet Active

Ergonomically designed soft seating promotes upright postures and active working behaviors for the task at hand.

Beautifully Designed

Reflect's asymmetrical aesthetic is visually compelling and intuitively offers ancillary worksurface support for beverages and writing with its extended width armrest.

CONSTRUCTION

Reflect is constructed of fabric covered foam with an upholstery-grade FSC plywood core with box joint and corner block construction.

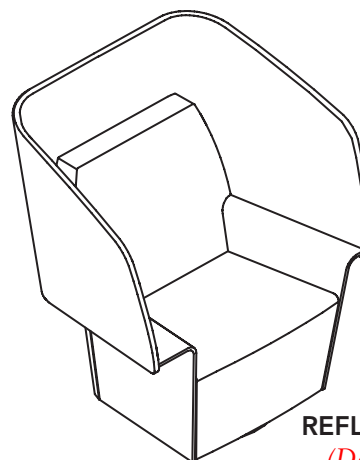

REFLECT GAWRP
(De-emphasized)

OPTIONS — REFLECT

FSC Certified Wood:

FSC FSC Certified Wood

Lower Shell Veneer Finish:

Stratawood Veneer

SE599 Field Elm Maple

SE800 Clear Maple

SE856 Harvest Maple

SE912 Phantom Ecru Maple
Oak

SE943 Belair Maple

SC701 Light Cherry

SC777 Burnished Cherry

SF300 Clear Oak

SF331 Dark Rift Cut

Seat/Back Upholstery:

See page 300 for upholstery selections.

Upper Shell Upholstery:

See page 300 for upholstery selections.

MATERIALS AND FINISHES

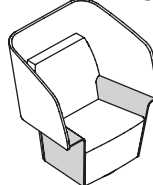

Lower Shell
Veneer Finish

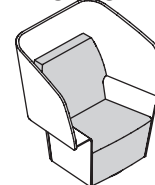

Seat/Back
Upholstery
Pattern Cut

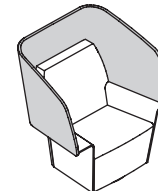

Upper Shell
Upholstery
Railroad Cut

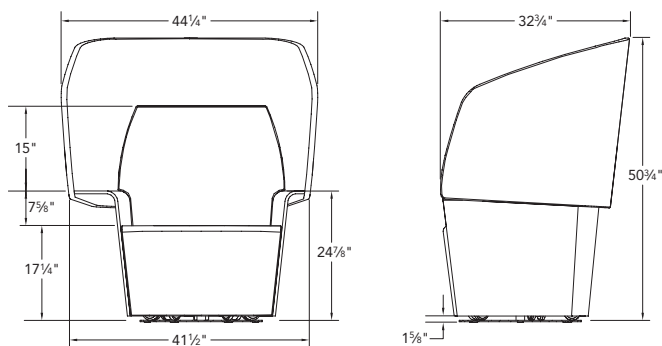
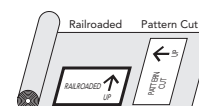
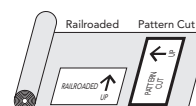

(See page 323 for COM upcharge pricing on Grades 9-18)

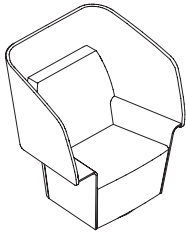

Model and Upholstery Option	Base List Price	Upcharge							
		1	2	3	4	5	6	7	8
Reflect									
GAWRP (<i>De-emphasized</i>)	\$ 8814	—	—	—	—	—	—	—	—
Seat/Back Upholstery – add to base price		\$ 0	\$ 53	\$ 106	\$ 158	\$ 229	\$ 299	\$ 369	\$ 440
Upper Shell Upholstery – add to base price		\$ 0	\$ 82	\$ 162	\$ 244	\$ 353	\$ 460	\$ 569	\$ 677

Pricing Example:	Model/Options	Base Price/Upcharges
Step 1: Select Model	GAWRP	\$ 8814
Step 2: Select Seat/Back Upholstery	Grade 2 Appoint Seating Carbon	\$ 53 upcharge
Step 3: Select Upper Shell Upholstery	Grade 4 Purl Deep	\$ 244 upcharge
Add Base + applicable Upcharges for Total List Price =		\$ 9111

REFLECT

Model Number	COM Yardage		Overall				Seat		Armrests				Backrest						
	COL Sq. Feet	Height	Width	Depth	Height	Width	Depth	Rear Angle	Armrest Height	Width Between Arms	Depth	Arm Height to Floor	Height	Width	Lumbar Height	Backrest/Seat Angle	Ship Weight	Cu Yds	
GAWRP			50 1/2"	44 1/2"	32 1/2"	17 1/2"	25 1/2"	20"	5.3°	7 1/2"	25 1/2"	22 1/2"	24 1/2"	24"	26"	9"	97°	196	64.4
Seat/Back	3.25	—																	
Upper Shell	5	—																	

<p>How to specify — Select the Model Number from above.</p>	<p>1st Option: FSC Certified Wood (if applicable): FSC Select for FSC Certified Wood</p>	<p>2nd Option: Select Lower Shell Veneer Finish: See page 301 for finishes.</p>	<p>3rd Option: Select the Seat/Back Upholstery: See page 300 for available colors and codes.</p>	<p>4th Option: Select the Upper Shell Upholstery: See page 300 for available Upper Shell colors and codes. CU Centurion NR Inertia (<i>De-emphasized</i>) WP Whisper SX Moxie</p>
<p>GAWRP .</p>	<p>F S C .</p>	<p>S .</p>	<p> .</p>	<p> .</p>

Example: GAWRP.FSC.SE800.SED08.WSP42

Social Collaborative Standard Upholstery Selections by Model/Series, for all other seating see pages 13-14.

Clubhouse – Front & Back Bag/Storage
Clubhouse – Seating / Consoles

Clubhouse – Front & Back Bag/Storage
Clubhouse – Seating / Consoles

LEATHER L1

Allsteel Leather	WTH		
Florence Leather	FLOR		

GRADE 1

Apex	APX		
Centurion	CU	•	•
Contourett	UR	•	•
Dapper	DAPR	•	•
Hamilton <i>(De-emphasized)</i>	HAM	•	•
Inertia <i>(De-emphasized)</i>	NR	•	•
Optic <i>(De-emphasized)</i>	OP		

GRADE 2

Appoint Seating	PNS	•	•
Blume	BLME	•	•
Clyde	CLYD	•	•
Dotty <i>(De-emphasized)</i>	DOT	•	•
Meld Ⓢ	SMHMMLD	•	•
Rush	RUSH	•	•
Spin Seating	SPNN	•	•
Whisper Vinyl	WP	•	•

GRADE 3

Lateral Ⓢ	SCFSLAT	•	•
Moxie	SX	•	•
Purl	PURL	•	•
Quill	QUL		•

GRADE 4

Caper Ⓢ	SMHMCAP	•	•
Manner Ⓢ	SMHMMAN	•	•
Merit Ⓢ	SMHMMER	•	•
Messenger Ⓢ	SMHMGRM	•	•
Metric Ⓢ	SMHMMET	•	•
Mode Ⓢ	SMHMMOD	•	•
Multiply Ⓢ	SMHMMLT	•	•
Murmur Ⓢ	SMHMMUR		
Muse Ⓢ	SMHMMUS		
Trundle Ⓢ	SMHMTRN	•	•

GRADE 5

Main Line Flax Ⓢ	SCAMMLF	•	•
Rove Ⓢ	SMHMROV	•	•

GRADE 6

Arris	ARR		•
Blazer	SCAMBLZ	•	•
Chock Ⓢ	SMHMCKK		
Hedge Ⓢ	SMHMHED	•	•
Pocket Ⓢ	SMHMPKT	•	•
Sequence Ⓢ	SMHMSQN		
Tandem Ⓢ	SMHMTAN		
Verse Ⓢ	SCARVRS	•	•

GRADE 8

Apt Ⓢ	SMHMAPT	•	•
Brisa Ⓢ	RS	•	•

GRADE 9

Ultraleather Pro Ⓢ	SUF554	•	•
--------------------	--------	---	---

GRADE 11

Fusion Ⓢ	SCARFUS	•	•
----------	---------	---	---

GRADE 13

Maze Ⓢ	SCARMZE	•	•
--------	---------	---	---

GRADE 14

Chroma Ⓢ	SCARCHR	•	•
----------	---------	---	---

CLUBHOUSE

- Ⓢ Partnership Program — See page 10 for details.
- ≠ Upholstery will be Railroad cut.
- Available upholstery option

TILE PAINT FINISHES

GRADE P1	
Textured Designer White	PK7
Textured Flint	P7A
GRADE P2	
Silver Texture.....	PR8
GRADE P4	
Polished Aluminum	PAL/P

TABLE EXTENSION PAINT FINISHES

GRADE P1	
Designer White.....	PJW
Flint	P02
GRADE P2	
Silver	PR6

LAMINATES

GRADE L1	
SOLID COLORS	
Black	P
Designer White.....	LDW1
Flint	LM16
Fossil Shale.....	LEH1
Loft	LM11
Muslin.....	LM15
Titanium	LTI1
ABSTRACT	
Handspun Pearl.....	LAHP
Handspun Dove	LAHD
Handspun Slate	LAHS
Handspun Chestnut	LAHC
WOODGRAIN	
Belair.....	LWBA
Bourbon Cherry	H
Field Elm.....	LWFE
Florence Walnut.....	LFW1
Kingswood Walnut	LKI1
Natural Maple	LWD
NeoWalnut	LNU1
Pinnacle.....	PINC
Shaker Cherry	LW7C
GRADE L2	
Beigewood.....	LWBE
Fawn Cypress	LFC1
Lowell Ash	LLA1
Mangalore Mango	LMM1
Natural Recon.....	LNR1
Phantom Charcoal	LPC1
Phantom Ecu	LPE1
Portico Teak.....	LPT1
Skyline Walnut.....	LSW1
Veranda Teak.....	LVT1
GRADE L3	
Natural Walnut.....	LWNW

LAMINATE EDGE COLORS

Beigewood.....	DE
Belair.....	BA
Black	E4
Bourbon Cherry	H
Brownstone.....	EY
Bungalow	EX
Designer White.....	DW
Fawn Cypress.....	FC
Field Elm.....	FE
Flint	E9
Florence Walnut.....	FW
Fossil.....	EH
Kingswood Walnut	KI
Loft.....	EV
Lowell Ash	DL
Mangalore Mango	MM
Muslin.....	EU
Natural Maple	DD
Natural Recon.....	NR
Natural Walnut.....	DN
NeoWalnut	NU
Parchment.....	EN
Phantom Charcoal	PC
Phantom Ecu	PE
Pinnacle.....	PI
Platinum Metallic.....	EP
Portico Teak.....	DP
Shaker Cherry	DF
Skyline Walnut.....	SW
Titanium	TI
Veranda Teak.....	VT

NOTE: Refer to individual product pages for upcharges.

FSC Certified Wood at Allsteel
See page 459 for more information.

The best work happens when the right people come together in the right space. A space that facilitates uninterrupted thought and sets team members up for everyday office victories.

Meet Clubhouse, the newest addition to Allsteel's Social Collaborative collection of furniture.

It's where seating, surface and seclusion come together. Clubhouse is easy to set up in any space and fits however your team works. Its framed design serves a dual purpose: promoting collaboration while reducing outside distractions by communicating to others that work is happening inside.

Great things happen in your go-to place. That's the beauty of Clubhouse – the get-together getaway space.

AVAILABLE CONFIGURATIONS

Clubhouse is available in fourteen unique configurations that span between two different heights. Optional console and storage components provide ancillary worksurface support, media wall applications support technology and a wide array of fabrics and finishes allow for creative expression.

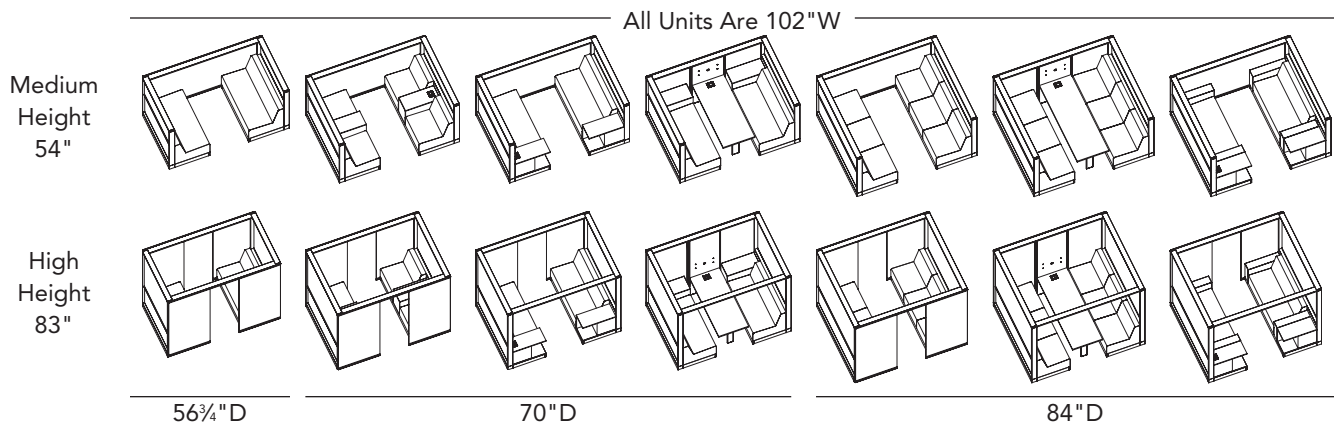

APPLICATION

Like its sister products, Clubhouse addresses the modern workplace's need for flexibility in an open office design. By forming — not filling — a room, Clubhouse creates a secluded space within any place:

- The brainstorm retreat.
- A private area for the job interview.
- The temporary office for writing that memo to the boss.

KEY FEATURES

Spatial Delineation

- Microarchitectural-like frame forms a 3D boundary and creates a space within a space.
- Semi-translucent back and side screening elements visually establish privacy and communicate unavailability

Extended Use Comfort

- Soft seating provides long-term comfort for small to mid-sized groups.
- Optional console and storage components provide ancillary work surface support.

Support for Technology

- Optional media wall and table support digital content sharing and power distribution.
- Integrated power within console and storage pieces further enable the usage of technology.

CONSTRUCTION

The construction of Clubhouse meets or exceeds industry standards for performance.

- Aluminum vertical uprights and horizontal extrusions are robust yet maintain a stream-line design.
- Back and side screens are made from durable polyester yarns. Screens are securely fastened across the top and a magnetic connection across the bottom allows the screen not to be damaged if impacted.
- Seating and console units are constructed of fabric covered foam with a plywood core.

ELECTRICAL

Electrical is to be separately specified and can be integrated within media walls, consoles and storage components. Standard, Chicago and New York electrical-coded models are available for specification throughout each of the previously indicated items.

When a media wall electrical assembly is specified, table top power integration is automatically included.

Console and storage power integration is only available on a single side of a Clubhouse configuration and is to be called out during the specification process.

Please refer to page 316 for additional information on electrical and power for Clubhouse.

NOTE: Clubhouse Typicals can be found at <https://www.allsteeloffice.com/design-resources/idea-starters>

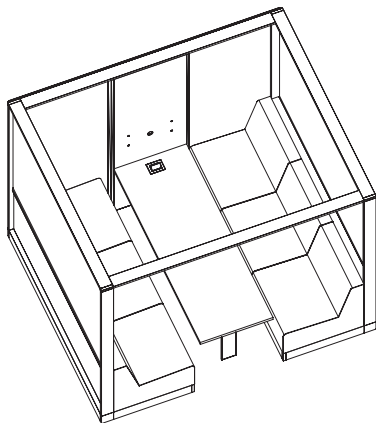

Clubhouse with Table and Media Wall, power ready.
GA84HMW
 84"D x 102"W x 83"H

SPECIFICATION
Fabric Specification

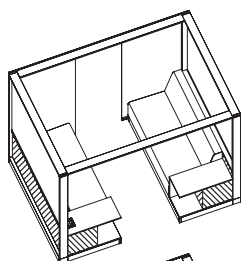

Frontboard, backboard and storage upholstery will match in specified fabric material.

Fabric is railroad cut.

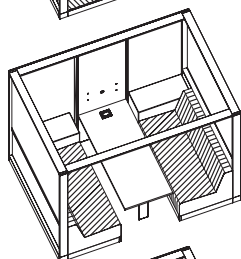
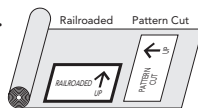

Seating top, back, seat and seat front upholstery will match in specified fabric material.

Fabric is pattern cut

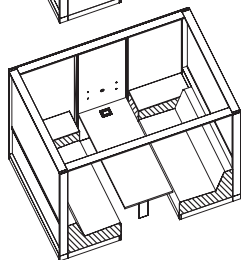
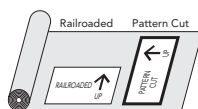

Seating side and console upholstery will match in specified fabric material.

Fabric is pattern cut

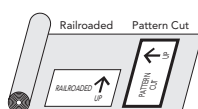

OPTIONS

Description:

GAxxM Medium Height (54"H x 102"W)

GAxxH High Height (83"H x 102"W)

Depth, Configuration, and Power:

- 56¼"D Seating – Non-powered
- 70"D Console (Upholstered or Laminate) – Powered or Non-Powered
- 70"D Storage – Powered L or R; or Non-Powered
- 70"D Table and Powered Media Wall
- 84"D Seating – Non-powered
- 84"D Storage – Powered L or R; or Non-Powered
- 84"D Table and Powered Media Wall

Frame Paint/Finish Color:

- P7A** Textured Flint
- PR8** Textured Silver
- PK7** Textured Designer White

Back and Sides Screen Material:

- CHK** Chalk
- GRS** Greystone
- PEW** Pewter

Table and Console Laminate with Matching Edge (*if applicable*):

GRADE L1

- L1 Abstract
- LT8D** Silver Mesh
- LAHPEH** Handspun Pearl/Fossil
- LAHDEH** Handspun Dove/Fossil
- LAHSE9** Handspun Slate/Flint
- LAHCEX** Handspun Chestnut/Bungalow

Solid Color

- LDW1DW** Designer White/Designer White
- LM15EU** Muslin/Muslin
- LM11EV** Loft/Loft
- LM16E9** Flint/Flint
- LEH1EH** Fossil Shale
- LT11TI** Titanium

Woodgrain

- LFW1FW** Florence Walnut
- LK11KI** Kingswood Walnut
- LWDDD** Natural Maple/Natural Maple
- LNU1NU** NeoWalnut
- LW7CDF** Shaker Cherry/Shaker Cherry

GRADE L2

- LWACDA** Amber Cherry/Amber Cherry
- LWBEDE** Beigewood/Beigewood
- LWBRDB** Brazilwood/Brazilwood
- LWZDZ** Columbian Walnut/Columbian Walnut
- LLA1DL** Lowell Ash
- LNR1NR** Natural Recon
- LPT1PT** Portico Teak
- LSW1SW** Skyline Walnut
- LVT1VT** Veranda Teak
- LBO1BO** Branded Oak
- LER1DR** Ebony Recon
- LFC1FC** Fawn Cypress
- LMM1MM** Mangalore Mango
- LPC1PC** Phantom Charcoal
- LPE1PE** Phantom Ecru

GRADE L3

- LWCDG** Cafelle/Cafelle
- LWCWDC** Charcoal Walnut/Charcoal Walnut
- LWNWDN** Natural Walnut/Natural Walnut

Frontboard, Backboard, and Storage Upholstery (*if applicable*):
 See upholstery selection on page 304).

Seating Top, Back, Seat, and Seat Front Upholstery:
 See upholstery selection on page 304).

Seating Side and Console Upholstery (*if applicable*):
 See upholstery selection on page 304).

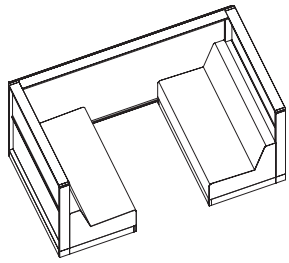

56 1/4"D x 102"W x 54"H with Seating – GA56MSE Units are non-powered.

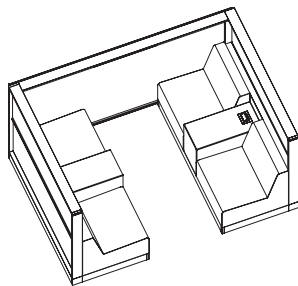
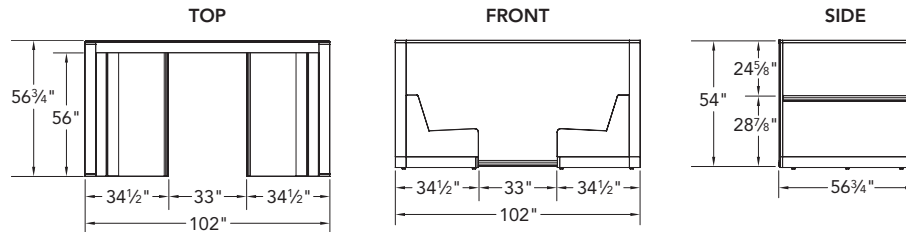

70"D x 102"W x 54"H with Console – GA70MCO Units available as power ready or as non-powered; center consoles are upholstered or laminate.

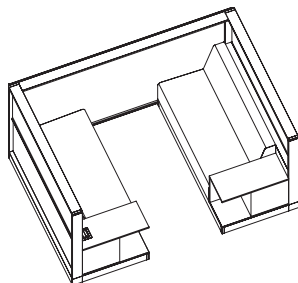
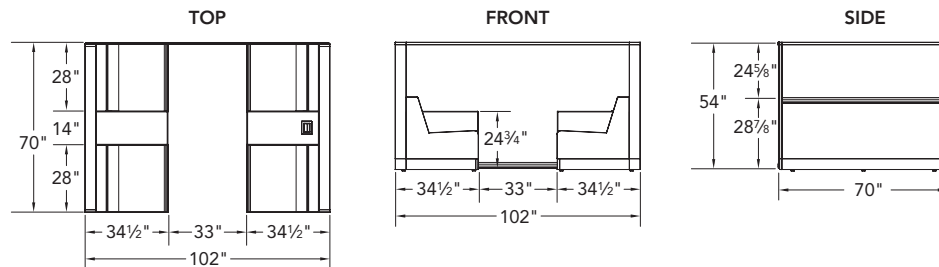

70"D x 102"W x 54"H with Storage – GA70MST Units available as power ready left or right, or as non-powered.

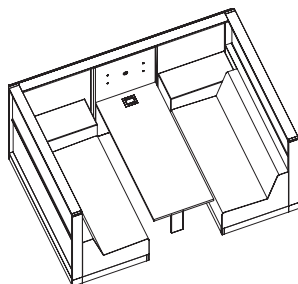
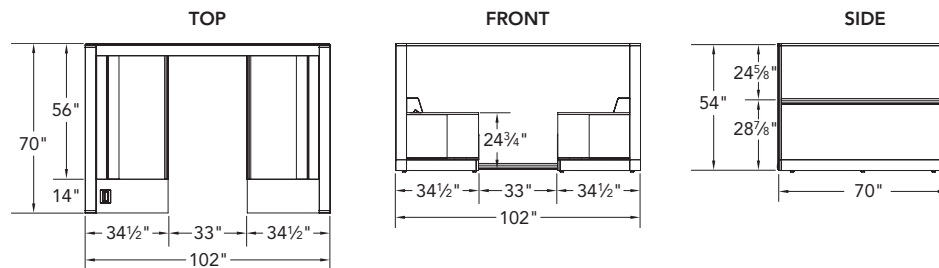

70"D x 102"W x 54"H with Table and Media Wall – GA70MM Units are power ready and available with or without end of bench consoles – either laminate or upholstered.

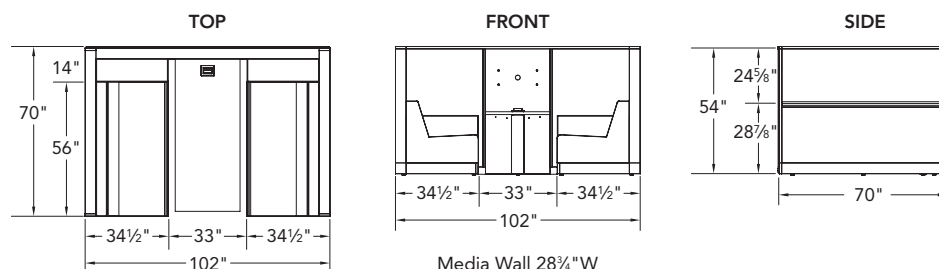

Media Wall 28 3/4"W
Table is 26 3/4"H

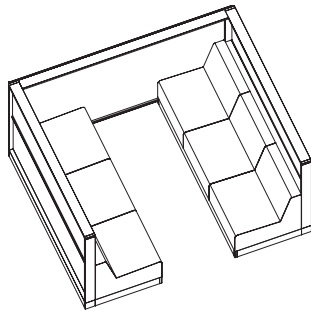

84"D x 102"W x 54"H with Seating – GA84MSE Units are non-powered.

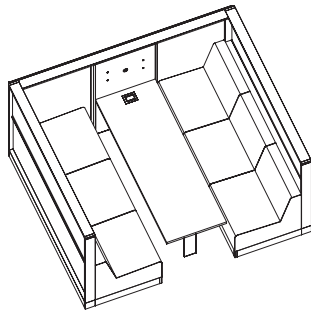
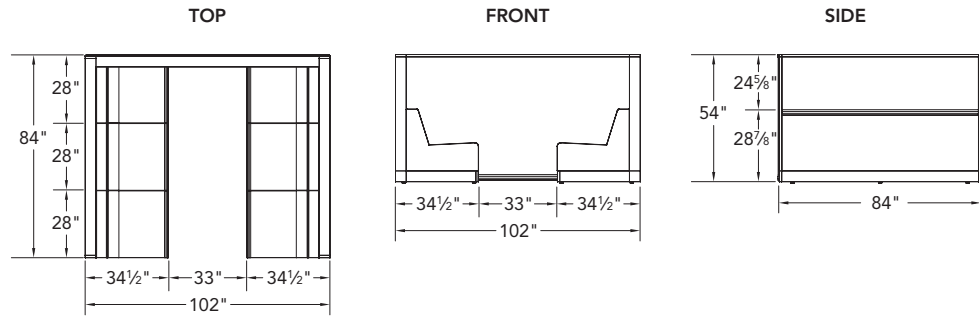

84"D x 102"W x 54"H with Table and Media Wall – GA84MMW Units are power ready.

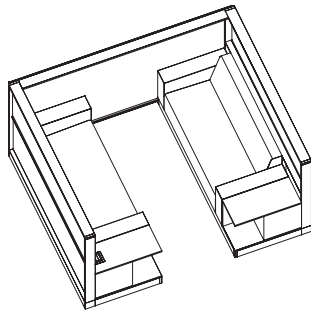
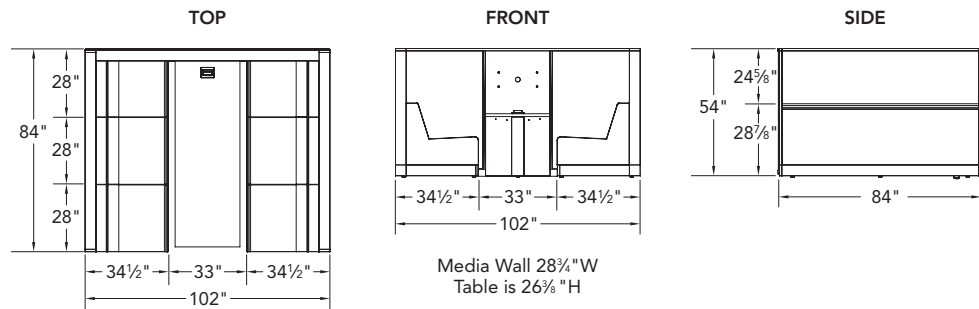

84"D x 102"W x 54"H with Table, Media Wall and Storage – GA84MST Units available as power ready left or right of seat; or as non-powered.

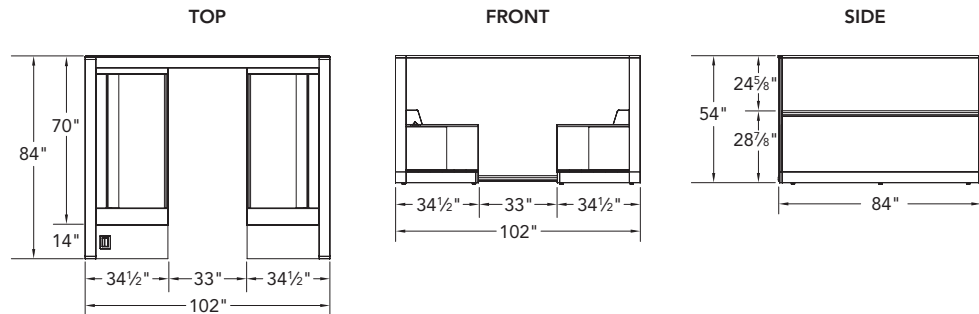

Above power is right of seat.

57½"D x 102"W x 83"H with Seating – GA56HSE Units are non-powered.

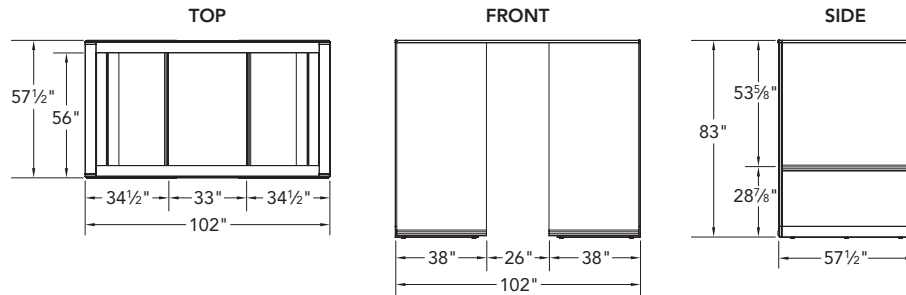
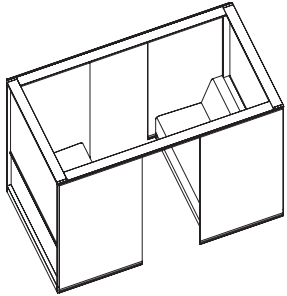

70"D x 102"W x 83"H with Console – GA70HCO Units available as power ready or as non-powered; center consoles are upholstered or laminate.

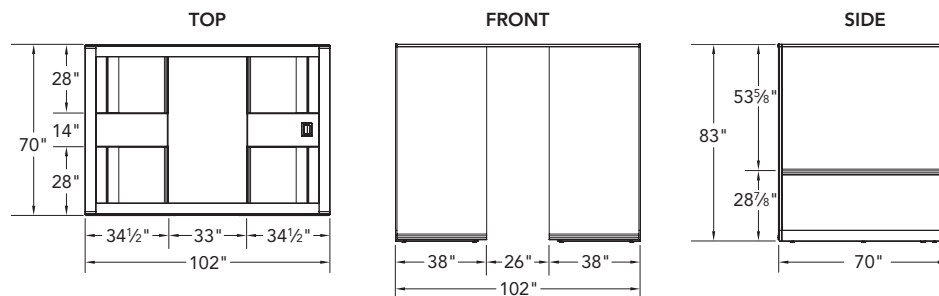
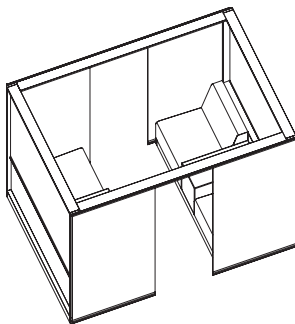

70"D x 102"W x 83"H with Storage – GA70HST Units available as powered left or right of seat, or as non-powered.

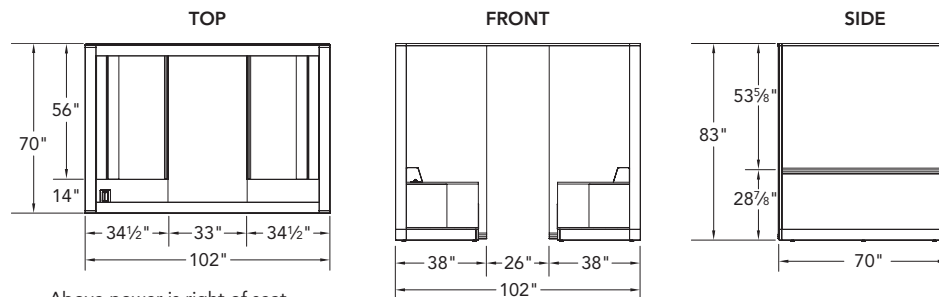
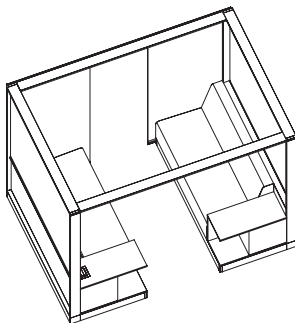

Above power is right of seat.

70"D x 102"W x 83"H with Table and Media Wall – GA70HM Units are power ready and available with or without end of bench consoles – either laminate or upholstered.

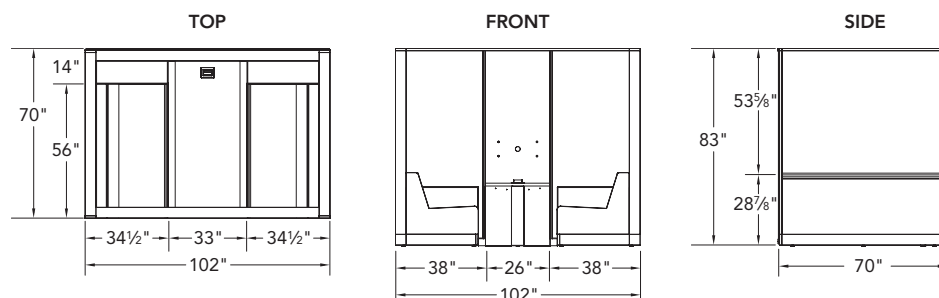
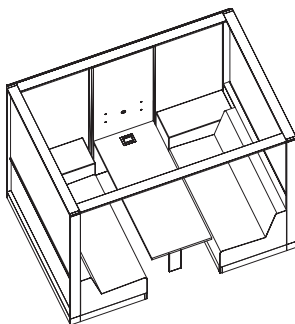

84"D x 102"W x 83"H with Seating – GA84HSE Units are non-powered.

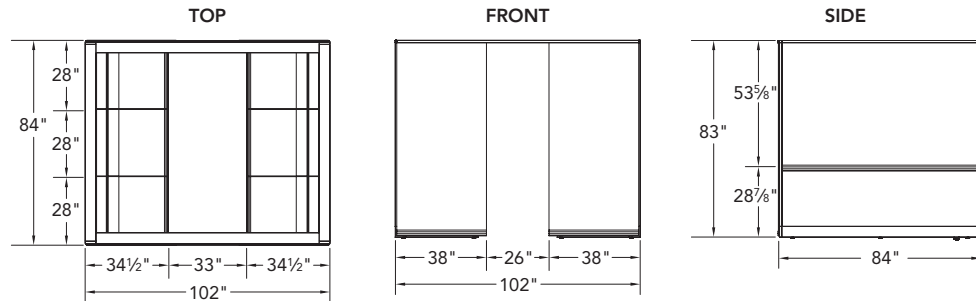
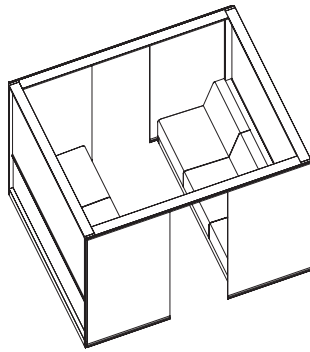

84"D x 102"W x 83"H with Table and Media Wall – GA84HMW Units are power ready.

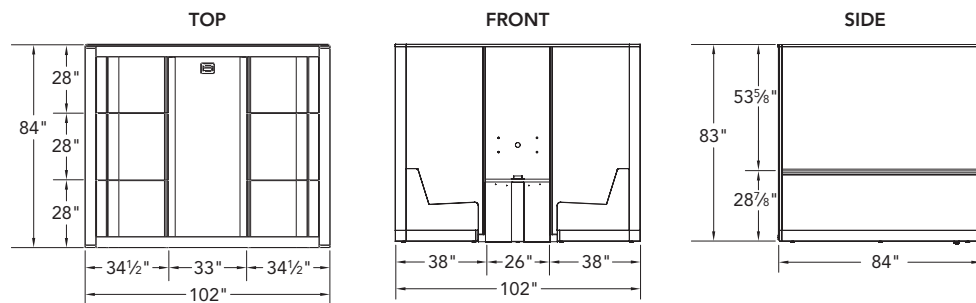
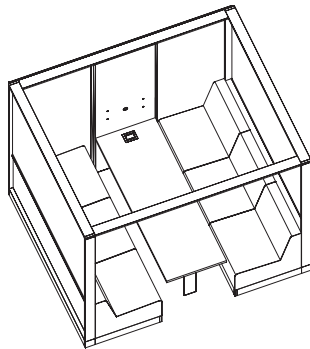

Media Wall 28¾"W
 Table is 26⅞"H

84"D x 102"W x 83"H with Table, Media Wall and Storage – GA84HST Units available as powered left or right of seat; or as non-powered.

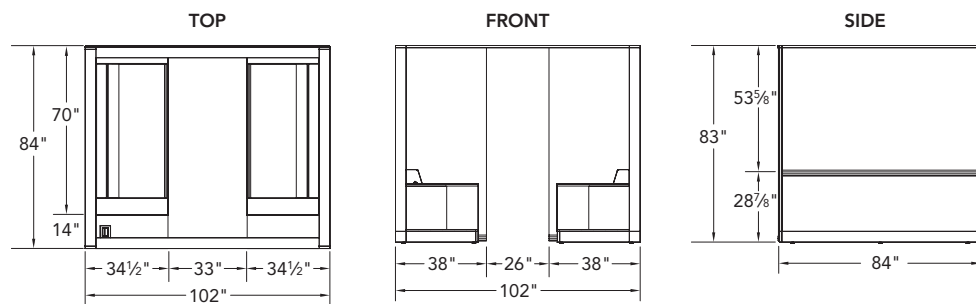
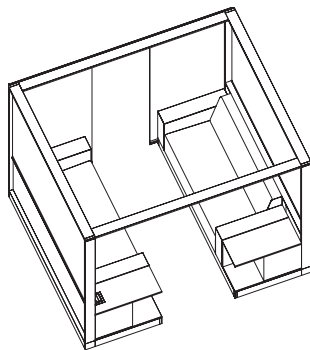

Above power is right of seat.

All units below are 54" H x 102" W

(See page 323 for COM pricing on 54" H Grades 7-18)

	Description	Model Options	Model Number	Base List Price	Option Upcharges by Grade Selected								
					1	2	3	4	5	6			
56 1/2" D Seating		56 1/2" D Seating, No Power	GA56MSE	\$ 21307	—	—	—	—	—	—			
		Frontboard/Backboard Upholstery			\$ 0	\$ 74	\$ 148	\$ 296	\$ 445	\$ 594			
		Seating Upholstery			\$ 0	\$ 181	\$ 361	\$ 723	\$ 1084	\$ 1445			
		Seating Side Upholstery			\$ 0	\$ 43	\$ 84	\$ 168	\$ 253	\$ 335			
70" D Consoles		70" D Uph. Consoles, Power Ready	GA70MCOUHP	\$ 28384	—	—	—	—	—	—			
		70" D Uph. Consoles, No Power	GA70MCOUNP	\$ 28382	—	—	—	—	—	—			
		Frontboard/Backboard Upholstery			\$ 0	\$ 74	\$ 148	\$ 296	\$ 445	\$ 594			
		Seating Upholstery			\$ 0	\$ 173	\$ 347	\$ 693	\$ 1040	\$ 1385			
		Seating Side/Console Upholstery			\$ 0	\$ 148	\$ 296	\$ 594	\$ 890	\$ 1188			
		70" D Lam. Consoles, Power Ready	GA70MCOLHP	\$ 29065	—	—	—	—	—	—			
		70" D Lam. Consoles, No Power	GA70MCOLNP	\$ 29062	—	—	—	—	—	—			
		Console Laminate/Laminate Edge			\$ 0	\$ 37	\$ 64	—	—	—			
70" D Storage		70" D Storage, Power Ready (Right of Seat — shown)	GA70MSTHR	\$ 27449	—	—	—	—	—	—			
		70" D Storage, Power Ready (Left of Seat)	GA70MSTHL	\$ 27449	—	—	—	—	—	—			
		70" D Storage, No Power	GA70MSTNP	\$ 27447	—	—	—	—	—	—			
		Storage Laminate/Laminate Edge			\$ 0	\$ 118	\$ 242	—	—	—			
		Frontboard/Backboard/Storage Uph.			\$ 0	\$ 86	\$ 173	\$ 347	\$ 520	\$ 693			
		Seating Upholstery			\$ 0	\$ 181	\$ 361	\$ 723	\$ 1084	\$ 1445			
		Seating Side Upholstery			\$ 0	\$ 43	\$ 84	\$ 168	\$ 253	\$ 335			
		70" D Media Wall*, Uph. Consoles, Power Ready	GA70MMCU	\$ 31476	—	—	—	—	—	—	—		
			Table/Media Wall Lam./Lam. Edge			\$ 0	\$ 159	\$ 317	—	—	—		
			Frontboard/Backboard Upholstery			\$ 0	\$ 74	\$ 148	\$ 296	\$ 445	\$ 594		
			Seating Upholstery			\$ 0	\$ 181	\$ 361	\$ 723	\$ 1084	\$ 1445		
			Seating Side/Console Upholstery			\$ 0	\$ 116	\$ 232	\$ 466	\$ 698	\$ 931		
			70" D Media Wall*, Lam. Consoles, Power Ready	GA70MMCL	\$ 32156	—	—	—	—	—	—	—	
		Table/Media Wall/Console Lam./Lam. Edge				\$ 0	\$ 195	\$ 380	—	—	—		
		Frontboard/Backboard Upholstery				\$ 0	\$ 74	\$ 148	\$ 296	\$ 445	\$ 594		
		Seating Upholstery				\$ 0	\$ 181	\$ 361	\$ 723	\$ 1084	\$ 1445		
		Seating Side/Console Upholstery				\$ 0	\$ 116	\$ 232	\$ 466	\$ 698	\$ 931		
		84" D Storage			84" D Seating, No Power	GA84MSE	\$ 29626	—	—	—	—	—	—
			Frontboard/Backboard Upholstery				\$ 0	\$ 74	\$ 148	\$ 296	\$ 445	\$ 594	
			Seating Upholstery				\$ 0	\$ 260	\$ 520	\$ 1040	\$ 1559	\$ 2079	
			Seating Side Upholstery				\$ 0	\$ 111	\$ 223	\$ 445	\$ 668	\$ 890	
			84" D Media Wall*, Power Ready		GA84MMW	\$ 34534	—	—	—	—	—	—	—
					Table/Media Wall Laminate/Laminate Edge			\$ 0	\$ 164	\$ 326	—	—	—
					Frontboard/Backboard Upholstery			\$ 0	\$ 74	\$ 148	\$ 296	\$ 445	\$ 594
Seating Upholstery						\$ 0	\$ 260	\$ 520	\$ 1040	\$ 1559	\$ 2079		
Seating Side Upholstery						\$ 0	\$ 111	\$ 223	\$ 445	\$ 668	\$ 890		
84" D Storage, Power Ready (Right of Seat — shown)	GA84MSTHR				\$ 33257	—	—	—	—	—	—	—	
	84" D Storage, Power Ready (Left of Seat)		GA84MSTHL		\$ 33257	—	—	—	—	—	—		
	84" D Storage, No Power		GA84MSTNP		\$ 33255	—	—	—	—	—	—		
	Storage Laminate/Laminate Edge					\$ 0	\$ 118	\$ 242	—	—	—		
	Frontboard/Backboard/Storage Uph.					\$ 0	\$ 86	\$ 173	\$ 347	\$ 520	\$ 693		
	Seating Upholstery					\$ 0	\$ 166	\$ 331	\$ 664	\$ 995	\$ 1326		
Seating Side Upholstery					\$ 0	\$ 156	\$ 312	\$ 624	\$ 936	\$ 1247			

*Order TV or Monitor Wall Mount separately. See page 317.

Continued on next page ▶

<p>How to specify — Select the Model Number from above.</p> <p>GA M .</p>	<p>1st Option: Select the Frame Paint/Finish Color:</p> <p>P7A Textured Flint PR8 Textured Silver PK7 Textured Designer White</p> <p> .</p>	<p>2nd Option: Select the Back and Side Screen Material:</p> <p>CHK Chalk GRS Greystone PEW Pewter</p> <p> .</p>	<p>3rd Option: Select the Laminate Finish and Edge for internal Table, Storage and Console Components (if applicable):</p> <p>See page 305 for laminate and edge selections.</p> <p> .</p>
--	---	--	--

Examples: GA56MSENO.P7A.GRS.CTU18.A119.CTU18 GA84MMWFC.P71.GRS.LWBEDE.CTU62.AI62.BOX10

Model Number	COM Yardage					Seat		Arms			Seat Back		Console or Storage		Table		Cubbs	
	Front/Backboard and Storage	Seat — Front, Seat, Back, Top	Seat Side and Console	Height from Floor (Plinth leveling glide variance)	Width	Depth to Bolster	Pan Angle	Height from Seat	Arm Pad Length	Arm Pad Width	Height	Inclination from Vertical	Depth	Width	Length	Width		Ship Weight
GA56MSE	4	8.5	2	16½"-18¼"	56"	20¼"	4°	—	—	—	16"	16.5	—	—	—	—	698	150
GA70MCOUHP	6.5	9	7.5	16½"-18¼"	28"	20¼"	4°	—	—	—	16"	16.5	18½"	14"	—	—	843	163
GA70MCOUNP	6.5	9	7.5	16½"-18¼"	28"	20¼"	4°	—	—	—	16"	16.5	18½"	14"	—	—	843	163
GA70MCOUHP	6.5	9	7.5	16½"-18¼"	28"	20¼"	4°	—	—	—	16"	16.5	18½"	14"	—	—	843	163
GA70MCOUNP	6.5	9	7.5	16½"-18¼"	28"	20¼"	4°	—	—	—	16"	16.5	18½"	14"	—	—	843	163
GA70MCOUHP	6.5	9	6.5	16½"-18¼"	28"	20¼"	4°	—	—	—	16"	16.5	19½"	14"	—	—	853	166
GA70MCOLHP	6.5	9	6.5	16½"-18¼"	28"	20¼"	4°	—	—	—	16"	16.5	19½"	14"	—	—	853	166
GA70MCOLNP	6.5	9	6.5	16½"-18¼"	28"	20¼"	4°	—	—	—	16"	16.5	19½"	14"	—	—	853	166
GA70MSTHR	8.5	8.5	2	16½"-18¼"	56"	20¼"	4°	—	—	—	16"	16.5	19½"	14"	—	—	839	182
GA70MSTHL	8.5	8.5	2	16½"-18¼"	56"	20¼"	4°	—	—	—	16"	16.5	19½"	14"	—	—	839	182
GA70MSTNP	8.5	8.5	2	16½"-18¼"	56"	20¼"	4°	—	—	—	16"	16.5	19½"	14"	—	—	839	182
GA70MSTHR	8.5	8.5	2	16½"-18¼"	56"	20¼"	4°	—	—	—	16"	16.5	19½"	14"	—	—	839	182
GA70MSTHL	8.5	8.5	2	16½"-18¼"	56"	20¼"	4°	—	—	—	16"	16.5	19½"	14"	—	—	839	182
GA70MSTNP	8.5	8.5	2	16½"-18¼"	56"	20¼"	4°	—	—	—	16"	16.5	19½"	14"	—	—	839	182
GA70MMCU	6.5	8.5	5.5	16½"-18¼"	56"	20¼"	4°	—	—	—	16"	16.5	18½"	14"	63½"	27"	1155	202
GA70MMCL	6.5	8.5	4.5	16½"-18¼"	56"	20¼"	4°	—	—	—	16"	16.5	19½"	14"	63½"	27"	1165	204
GA84MSE	5	13.5	6	16½"-18¼"	28"	20¼"	4°	—	—	—	16"	16.5	—	—	—	—	926	193
GA84MMW	5	13.5	6	16½"-18¼"	28"	20¼"	4°	—	—	—	16"	16.5	—	—	77½"	27"	1236	215
GA84MSTHR	10.5	8.5	8	16½"-18¼"	56"	20¼"	4°	9½"	23"	7"	16"	16.5	19½"	14"	—	—	1020	215
GA84MSTHL	10.5	8.5	8	16½"-18¼"	56"	20¼"	4°	9½"	23"	7"	16"	16.5	19½"	14"	—	—	1020	215
GA84MSTNP	10.5	8.5	8	16½"-18¼"	56"	20¼"	4°	9½"	23"	7"	16"	16.5	19½"	14"	—	—	1020	215



◀ Continued from previous page

<p>4th Option: Select the Frontboard/ Backboard and Storage Upholstery (if applicable): See page 304 for upholstery selections.</p>	<p>5th Option: Select the Seating Upholstery: See page 304 for upholstery selections.</p>	<p>6th Option: Select the Seating Side and Console Upholstery (if applicable): See page 304 for upholstery selections.</p>
<input type="checkbox"/> <input type="checkbox"/> <input type="checkbox"/> <input type="checkbox"/> <input type="checkbox"/> <input type="checkbox"/> <input type="checkbox"/> <input type="checkbox"/> <input type="checkbox"/> <input type="checkbox"/> <input type="checkbox"/>	<input type="checkbox"/> <input type="checkbox"/> <input type="checkbox"/> <input type="checkbox"/> <input type="checkbox"/> <input type="checkbox"/> <input type="checkbox"/> <input type="checkbox"/> <input type="checkbox"/> <input type="checkbox"/> <input type="checkbox"/>	<input type="checkbox"/> <input type="checkbox"/> <input type="checkbox"/> <input type="checkbox"/> <input type="checkbox"/> <input type="checkbox"/> <input type="checkbox"/> <input type="checkbox"/> <input type="checkbox"/> <input type="checkbox"/> <input type="checkbox"/>

All units below are 83"H x 102"W

(See page 324 for COM pricing on 83"H Grades 7-18)

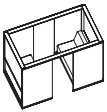
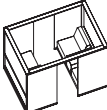
CLUBHOUSE

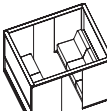
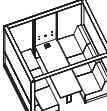
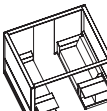
	Description	Model Options	Model Number	Base List Price	Option Upcharges by Grade Selected					
					1	2	3	4	5	6
56 1/2"D Seating		56 1/4"D Seating, No Power	GA56HSE	\$ 24492	—	—	—	—	—	—
		Frontboard/Backboard Upholstery			\$ 0	\$ 74	\$ 148	\$ 296	\$ 445	\$ 594
		Seating Upholstery			\$ 0	\$ 181	\$ 361	\$ 723	\$ 1084	\$ 1445
		Seating Side Upholstery			\$ 0	\$ 43	\$ 84	\$ 168	\$ 253	\$ 335
70"D Consoles		70"D Upholstered Consoles, Power Ready	GA70HCOUHP	\$ 31630	—	—	—	—	—	—
		70"D Upholstered Consoles, No Power	GA70HCOUNP	\$ 31628	—	—	—	—	—	—
		Frontboard/Backboard Upholstery			\$ 0	\$ 74	\$ 148	\$ 296	\$ 445	\$ 594
		Seating Upholstery			\$ 0	\$ 173	\$ 347	\$ 693	\$ 1040	\$ 1385
		Seating Side/Console Upholstery			\$ 0	\$ 148	\$ 296	\$ 594	\$ 890	\$ 1188
		70"D Laminate Consoles, Power Ready	GA70HCOLHP	\$ 32311	—	—	—	—	—	—
		70"D Laminate Consoles, No Power	GA70HCLNLP	\$ 32308	—	—	—	—	—	—
		Console Laminate/Laminate Edge			\$ 0	\$ 37	\$ 64	—	—	—
		Frontboard/Backboard Upholstery			\$ 0	\$ 74	\$ 148	\$ 296	\$ 445	\$ 594
		Seating Upholstery			\$ 0	\$ 173	\$ 347	\$ 693	\$ 1040	\$ 1385
Seating Side/Console Upholstery			\$ 0	\$ 148	\$ 296	\$ 594	\$ 890	\$ 1188		
70"D Storage		70"D Storage, Power Ready (Right of Seat — shown)	GA70HSTHR	\$ 29078	—	—	—	—	—	—
		70"D Storage, Power Ready (Left of Seat)	GA70HSTHL	\$ 29078	—	—	—	—	—	—
		70"D Storage, No Power	GA70HSTNP	\$ 29066	—	—	—	—	—	—
		Storage Laminate/Laminate Edge			\$ 0	\$ 118	\$ 242	—	—	—
		Frontboard/Backboard/Storage Upholstery			\$ 0	\$ 86	\$ 173	\$ 347	\$ 520	\$ 693
		Seating Upholstery			\$ 0	\$ 181	\$ 361	\$ 723	\$ 1084	\$ 1445
		Seating Side Upholstery			\$ 0	\$ 43	\$ 84	\$ 168	\$ 253	\$ 335
70"D Media Wall & Consoles		70"D Media Wall*, Uph. Consoles, Power Ready	GA70HMCU	\$ 34583	—	—	—	—	—	—
		Table/Media Wall Laminate/Laminate Edge			\$ 0	\$ 201	\$ 399	—	—	—
		Frontboard/Backboard Upholstery			\$ 0	\$ 74	\$ 148	\$ 296	\$ 445	\$ 594
		Seating Upholstery			\$ 0	\$ 181	\$ 361	\$ 723	\$ 1084	\$ 1445
		Seating Side/Console Upholstery			\$ 0	\$ 116	\$ 232	\$ 466	\$ 698	\$ 931
		70"D Media Wall*, Lam. Consoles, Power Ready	GA70HMCL	\$ 35263	—	—	—	—	—	—
		Table/Media Wall/Console Lam./Lam. Edge			\$ 0	\$ 201	\$ 399	—	—	—
		Frontboard/Backboard Upholstery			\$ 0	\$ 74	\$ 148	\$ 296	\$ 445	\$ 594
		Seating Upholstery			\$ 0	\$ 181	\$ 361	\$ 723	\$ 1084	\$ 1445
		Seating Side/Console Upholstery			\$ 0	\$ 116	\$ 232	\$ 466	\$ 698	\$ 931
84"D Seating		84"D Seating, No Power	GA84HSE	\$ 33024	—	—	—	—	—	—
		Frontboard/Backboard Upholstery			\$ 0	\$ 74	\$ 148	\$ 296	\$ 445	\$ 594
		Seating Upholstery			\$ 0	\$ 260	\$ 520	\$ 1040	\$ 1559	\$ 2079
		Seating Side Upholstery			\$ 0	\$ 111	\$ 223	\$ 445	\$ 668	\$ 890
84"D Media Wall		84"D Media Wall*, Power Ready	GA84HMW	\$ 37793	—	—	—	—	—	—
		Table/Media Wall Laminate/Laminate Edge			\$ 0	\$ 24	\$ 45	—	—	—
		Frontboard/Backboard Upholstery			\$ 0	\$ 74	\$ 148	\$ 296	\$ 445	\$ 594
		Seating Upholstery			\$ 0	\$ 260	\$ 520	\$ 1040	\$ 1559	\$ 2079
Seating Side Upholstery			\$ 0	\$ 111	\$ 223	\$ 445	\$ 668	\$ 890		
84"D Storage		84"D Storage, Power Ready (Right of Seat — shown)	GA84HSTHR	\$ 35038	—	—	—	—	—	—
		84"D Storage, Power Ready (Left of Seat)	GA84HSTHL	\$ 35038	—	—	—	—	—	—
		84"D Storage, No Power	GA84HSTNP	\$ 35036	—	—	—	—	—	—
		Storage Laminate/Laminate Edge			\$ 0	\$ 118	\$ 242	—	—	—
		Frontboard/Backboard/Storage Upholstery			\$ 0	\$ 86	\$ 173	\$ 347	\$ 520	\$ 693
		Seating Upholstery			\$ 0	\$ 166	\$ 331	\$ 664	\$ 995	\$ 1326
Seating Side Upholstery			\$ 0	\$ 156	\$ 312	\$ 624	\$ 936	\$ 1247		

*Order TV or Monitor Wall Mount separately. See page 317.

Continued on next page ►

<p>How to specify — Select the Model Number from above.</p> <p>GA H . .</p>	<p>1st Option: Select the Frame Paint/Finish Color:</p> <p>P7A Textured Flint PR8 Textured Silver PK7 Textured Designer White</p>	<p>2nd Option: Select the Back and Side Screen Material:</p> <p>CHK Chalk GRS Greystone PEW Pewter</p>	<p>3rd Option: Select the Laminate Finish and Edge for internal Table, Storage and Console Components (if applicable):</p> <p>See page 305 for laminate and edge selections.</p>
--	--	---	---

Examples: GA56HSENO.P7A.GRS.CTU18.AI19.CTU18 GA84HMWFC.P71.GRS.LWBEDE.CTU62. AI62.BOX10

Model Number	COM Yardage					Seat		Arms			Seat Back		Console or Storage		Table		Cubes	
	Front/Backboard and Storage	Seat — Front, Seat, Back, Top	Seat Side and Console	Height from Floor (Plinth leveling glide variance)	Width	Depth to Bolster	Pan Angle	Height from Seat	Arm Pad Length	Arm Pad Width	Height	Inclination from Vertical	Depth	Width	Length	Width		Ship Weight
GA56HSE	4	8.5	2	16½"-18¼"	56"	20¼"	4°	—	—	—	16"	16.5	—	—	—	—	732	149
GA70HCOUHP	6.5	9	7.5	16½"-18¼"	28"	20¼"	4°	—	—	—	16"	16.5	18½"	14"	—	—	877	162
GA70HCOUNP	6.5	9	7.5	16½"-18¼"	28"	20¼"	4°	—	—	—	16"	16.5	18½"	14"	—	—	877	162
GA70HCOLHP	6.5	9	6.5	16½"-18¼"	28"	20¼"	4°	—	—	—	16"	16.5	19½"	14"	—	—	887	166
GA70HCOLNP	6.5	9	6.5	16½"-18¼"	28"	20¼"	4°	—	—	—	16"	16.5	19½"	14"	—	—	887	166
GA70HSTHR	8.5	8.5	2	16½"-18¼"	56"	20¼"	4°	—	—	—	16"	16.5	19½"	14"	—	—	863	181
GA70HSTHL	8.5	8.5	2	16½"-18¼"	56"	20¼"	4°	—	—	—	16"	16.5	19½"	14"	—	—	863	181
GA70HSTNP	8.5	8.5	2	16½"-18¼"	56"	20¼"	4°	—	—	—	16"	16.5	19½"	14"	—	—	863	181
GA70HMCU	6.5	8.5	5.5	16½"-18¼"	56"	20¼"	4°	—	—	—	16"	16.5	18½"	14"	63½"	27"	1209	208
GA70HMCL	6.5	8.5	4.5	16½"-18¼"	56"	20¼"	4°	—	—	—	16"	16.5	19½"	14"	63½"	27"	1219	212
GA84HSE	5	13.5	6	16½"-18¼"	28"	20¼"	4°	—	—	—	16"	16.5	—	—	—	—	960	192
GA84HMW	5	13.5	6	16½"-18¼"	28"	20¼"	4°	—	—	—	16"	16.5	—	—	77½"	27"	1290	221
GA84HSTHR	10.5	8.5	8	16½"-18¼"	56"	20¼"	4°	9½"	23"	7"	16"	16.5	19½"	14"	—	—	1044	214
GA84HSTHL	10.5	8.5	8	16½"-18¼"	56"	20¼"	4°	9½"	23"	7"	16"	16.5	19½"	14"	—	—	1044	214
GA84HSTNP	10.5	8.5	8	16½"-18¼"	56"	20¼"	4°	9½"	23"	7"	16"	16.5	19½"	14"	—	—	1044	214

◀ Continued from previous page

<p>4th Option: Select the Frontboard/Backboard and Storage Upholstery (if applicable): See page 304 for upholstery selections.</p>	<p>5th Option: Select the Seating Upholstery: See page 304 for upholstery selections.</p>	<p>6th Option: Select the Seating Side and Console Upholstery (if applicable): See page 304 for upholstery selections.</p>
---	--	---

CONSOLE AND STORAGE ELECTRICAL

Console and storage Clubhouse units that are “power ready” require electrical module kits to be ordered separately based on local requirements. Select either Standard, Hardwire, or New York standard kits. Consult with your local electrician for the unit that is in compliance

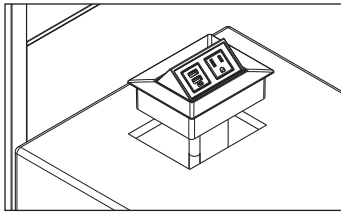

with local and national electrical codes. Verify code requirements before ordering. Chicago requires hardwiring. Exposed power module (shown) consists of one simplex receptacle and one USB hub for powering two devices.

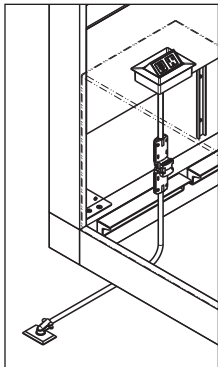

Standard Kit

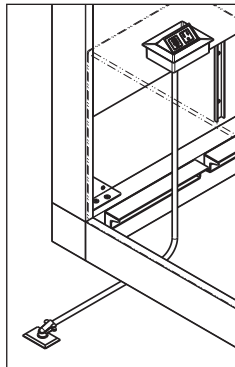

Hardwire Kit

Standard Electrical Kit for Clubhouse “power ready” console or storage units comes with one power module with 72" cord, H-connector, and a 72" sealtight infeed cable. The infeed cable can be connected to a power monument located within the plinth base on the side where the powered console or storage unit is located; or it can be routed under the plinth base to an external power monument as shown above.

Hardwire Electrical Kit for Clubhouse “power ready” console or storage units comes with one power module with a 110" of flex cable. The infeed cable can be connected to a power monument located within the plinth base on the side where the powered console or storage unit is located; or it can be routed under the plinth base to an external power monument as shown above.

New York Electrical Kit for Clubhouse “power ready” console or storage comes with one power module, H-connector, and cable to New York infeed box which can be attached to the inside surface of plinth base.

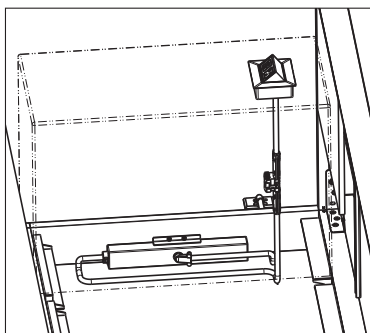

MEDIA WALL ELECTRICAL

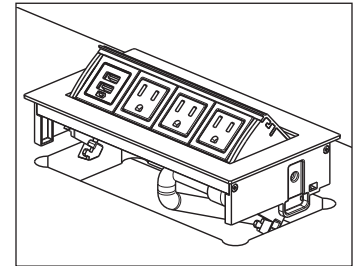
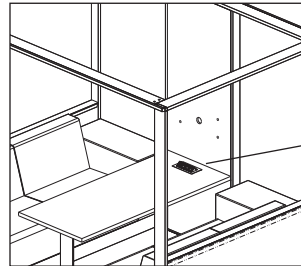

Media Wall Clubhouse units are “power ready” and require electrical module kits to be ordered separately based on local requirements. Select either Standard, Hardwire, or New York Standard kits. Consult with your local electrician for the unit that is in compliance with local and national electrical codes. Verify code requirements before ordering. Chicago requires hardwiring. Exposed power module (shown above) consists of three simplex receptacles and a USB hub for powering two devices.

Standard Electrical Kit for Clubhouse “power ready” media wall units comes with one external power module (described above), one internal power module with two simplex outlets to power monitor and accessory, H-connector, and a 72" sealtight infeed cable.

The infeed cable for Standard or Hardwire electrical can be connected to a power monument located within the plinth base on either side of unit; or it can be routed under the plinth base to an external power monument as shown above.

Hardwire Electrical Kit for Clubhouse media wall units comes with one external power module (described above), one internal power module with 72" cord and two simplex outlets to power monitor and accessory, H-connector, and a 72" flex infeed cable.

New York Electrical Kit for Clubhouse media wall units comes with one external power module (described above), one internal power module with 72" cord and two simplex outlets to power monitor and accessory, H-connector, and cable to New York infeed box which can be attached to the inside surface of plinth base (shown at right).

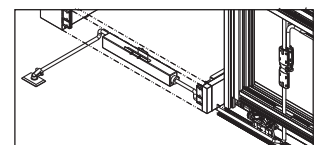
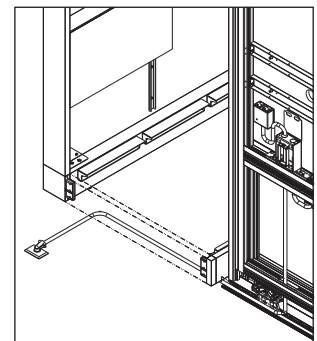
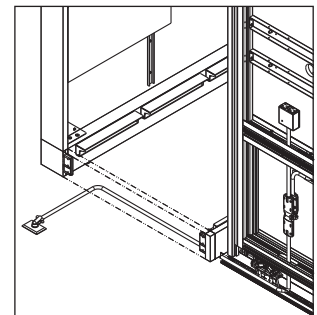

Model Number	Grade 9	Grade 10	Grade 11	Grade 12	Grade 13	Grade 14	Grade 15	Grade 16	Grade 17	Grade 18	Grade 19	Grade 20	Grade 21	Grade 22	
TOWNHALL ROCK SINGLE UPHOLSTERY — Pages 208-209															
ACEGUS	\$ 2648	\$ 784	\$ 894	\$ 1002	\$ 1109	\$ 1245	\$ 1380	\$ 1516	\$ 1651	\$ 1787	\$ 1920	\$ 2056	\$ 2191	\$ 2327	\$ 2462
TOWNHALL ROCK MULTI UPHOLSTERY — Pages 208-209															
ACEGUM	\$ 2779														
Seat/Cushion	\$ 393	\$ 446	\$ 501	\$ 555	\$ 623	\$ 691	\$ 758	\$ 826	\$ 894	\$ 960	\$ 1028	\$ 1095	\$ 1164	\$ 1231	
Back/Shell/Body	\$ 551	\$ 626	\$ 702	\$ 777	\$ 871	\$ 967	\$ 1060	\$ 1155	\$ 1251	\$ 1345	\$ 1439	\$ 1534	\$ 1629	\$ 1724	
TOWNHALL WEDGE MULTI UPHOLSTERY — Pages 210-211															
ACWEDM	\$ 3767														
Seat	\$ 157	\$ 180	\$ 201	\$ 222	\$ 249	\$ 277	\$ 303	\$ 330	\$ 358	\$ 385	\$ 411	\$ 439	\$ 466	\$ 493	
Back	\$ 471	\$ 536	\$ 601	\$ 666	\$ 747	\$ 829	\$ 909	\$ 990	\$ 1072	\$ 1153	\$ 1233	\$ 1316	\$ 1396	\$ 1478	
TOWNHALL WEDGE SINGLE UPHOLSTERY — Pages 210-211															
ACWEDS	\$ 3588	\$ 629	\$ 715	\$ 802	\$ 888	\$ 995	\$ 1105	\$ 1213	\$ 1320	\$ 1429	\$ 1537	\$ 1645	\$ 1754	\$ 1862	\$ 1970
TOWNHALL PEAK MULTI UPHOLSTERY — Pages 204-205															
ACVISDLM	\$ 4904														
Seat	\$ 566	\$ 643	\$ 720	\$ 799	\$ 897	\$ 993	\$ 1091	\$ 1189	\$ 1287	\$ 1383	\$ 1481	\$ 1578	\$ 1676	\$ 1773	
Back	\$ 487	\$ 555	\$ 621	\$ 689	\$ 772	\$ 855	\$ 940	\$ 1023	\$ 1108	\$ 1191	\$ 1276	\$ 1359	\$ 1442	\$ 1527	
Welt	\$ 315	\$ 358	\$ 401	\$ 444	\$ 498	\$ 553	\$ 606	\$ 660	\$ 715	\$ 769	\$ 822	\$ 877	\$ 931	\$ 985	
ACVISDRM	\$ 4904														
Seat	\$ 566	\$ 643	\$ 720	\$ 799	\$ 897	\$ 993	\$ 1091	\$ 1189	\$ 1287	\$ 1383	\$ 1481	\$ 1578	\$ 1676	\$ 1773	
Back	\$ 487	\$ 555	\$ 621	\$ 689	\$ 772	\$ 855	\$ 940	\$ 1023	\$ 1108	\$ 1191	\$ 1276	\$ 1359	\$ 1442	\$ 1527	
Welt	\$ 315	\$ 358	\$ 401	\$ 444	\$ 498	\$ 553	\$ 606	\$ 660	\$ 715	\$ 769	\$ 822	\$ 877	\$ 931	\$ 985	
ACVISSLM	\$ 3268														
Seat	\$ 235	\$ 268	\$ 301	\$ 333	\$ 373	\$ 415	\$ 455	\$ 495	\$ 536	\$ 577	\$ 617	\$ 658	\$ 698	\$ 739	
Back	\$ 283	\$ 322	\$ 360	\$ 399	\$ 449	\$ 497	\$ 545	\$ 595	\$ 643	\$ 692	\$ 741	\$ 789	\$ 839	\$ 887	
Welt	\$ 204	\$ 232	\$ 260	\$ 289	\$ 324	\$ 359	\$ 394	\$ 430	\$ 465	\$ 499	\$ 535	\$ 570	\$ 605	\$ 641	
ACVISSRM	\$ 3268														
Seat	\$ 235	\$ 268	\$ 301	\$ 333	\$ 373	\$ 415	\$ 455	\$ 495	\$ 536	\$ 577	\$ 617	\$ 658	\$ 698	\$ 739	
Back	\$ 283	\$ 322	\$ 360	\$ 399	\$ 449	\$ 497	\$ 545	\$ 595	\$ 643	\$ 692	\$ 741	\$ 789	\$ 839	\$ 887	
Welt	\$ 204	\$ 232	\$ 260	\$ 289	\$ 324	\$ 359	\$ 394	\$ 430	\$ 465	\$ 499	\$ 535	\$ 570	\$ 605	\$ 641	
TOWNHALL PEAK SINGLE UPHOLSTERY — Pages 204-205															
ACVISDLS	\$ 4670	\$ 1365	\$ 1554	\$ 1742	\$ 1931	\$ 2166	\$ 2401	\$ 2636	\$ 2872	\$ 3108	\$ 3342	\$ 3578	\$ 3814	\$ 4048	\$ 4284
ACVISDRS	\$ 4670	\$ 1365	\$ 1554	\$ 1742	\$ 1931	\$ 2166	\$ 2401	\$ 2636	\$ 2872	\$ 3108	\$ 3342	\$ 3578	\$ 3814	\$ 4048	\$ 4284
ACVISSLS	\$ 3113	\$ 721	\$ 821	\$ 921	\$ 1020	\$ 1145	\$ 1269	\$ 1394	\$ 1519	\$ 1643	\$ 1767	\$ 1892	\$ 2016	\$ 2141	\$ 2265
ACVISSRS	\$ 3113	\$ 721	\$ 821	\$ 921	\$ 1020	\$ 1145	\$ 1269	\$ 1394	\$ 1519	\$ 1643	\$ 1767	\$ 1892	\$ 2016	\$ 2141	\$ 2265
ACVISOTS	\$ 2024	\$ 594	\$ 674	\$ 755	\$ 839	\$ 940	\$ 1042	\$ 1143	\$ 1246	\$ 1347	\$ 1450	\$ 1553	\$ 1654	\$ 1756	\$ 1857
TOWNHALL SUMMIT STOOL — Page 214															
ACPERU	\$ 992	\$ 79	\$ 90	\$ 101	\$ 111	\$ 124	\$ 137	\$ 152	\$ 165	\$ 180	\$ 193	\$ 206	\$ 220	\$ 233	\$ 247
PARK LOUNGE SINGLE UPHOLSTERY — Pages 218-219															
NALS	\$ 3373	\$ 381	\$ 433	\$ 486	\$ 538	\$ 604	\$ 670	\$ 735	\$ 801	\$ 867	\$ 932	\$ 998	\$ 1063	\$ 1130	\$ 1195
NALD	\$ 5509	\$ 534	\$ 607	\$ 681	\$ 754	\$ 845	\$ 938	\$ 1029	\$ 1121	\$ 1214	\$ 1305	\$ 1397	\$ 1489	\$ 1581	\$ 1673
NAHS	\$ 4405	\$ 534	\$ 607	\$ 681	\$ 754	\$ 845	\$ 938	\$ 1029	\$ 1121	\$ 1214	\$ 1305	\$ 1397	\$ 1489	\$ 1581	\$ 1673
NAHD	\$ 7403	\$ 761	\$ 867	\$ 972	\$ 1076	\$ 1208	\$ 1339	\$ 1471	\$ 1602	\$ 1734	\$ 1864	\$ 1996	\$ 2127	\$ 2259	\$ 2390
PARK LOUNGE MULTI-UPHOLSTERY — Pages 220-221															
NALSM	\$ 3546														
Seat	\$ 76	\$ 87	\$ 98	\$ 107	\$ 120	\$ 133	\$ 147	\$ 160	\$ 174	\$ 187	\$ 200	\$ 213	\$ 226	\$ 239	
Back	\$ 305	\$ 347	\$ 389	\$ 431	\$ 483	\$ 536	\$ 588	\$ 640	\$ 694	\$ 746	\$ 798	\$ 851	\$ 903	\$ 956	
NALDM	\$ 5783														
Seat	\$ 137	\$ 156	\$ 175	\$ 193	\$ 217	\$ 241	\$ 264	\$ 288	\$ 312	\$ 335	\$ 359	\$ 383	\$ 407	\$ 430	
Back	\$ 442	\$ 503	\$ 564	\$ 625	\$ 700	\$ 777	\$ 853	\$ 929	\$ 1005	\$ 1082	\$ 1158	\$ 1234	\$ 1310	\$ 1386	
NAHSM	\$ 4629														
Seat	\$ 137	\$ 156	\$ 175	\$ 193	\$ 217	\$ 241	\$ 264	\$ 288	\$ 312	\$ 335	\$ 359	\$ 383	\$ 407	\$ 430	
Back	\$ 442	\$ 503	\$ 564	\$ 625	\$ 700	\$ 777	\$ 853	\$ 929	\$ 1005	\$ 1082	\$ 1158	\$ 1234	\$ 1310	\$ 1386	
NAHDM	\$ 7773														
Seat	\$ 320	\$ 363	\$ 408	\$ 452	\$ 507	\$ 563	\$ 617	\$ 673	\$ 728	\$ 783	\$ 839	\$ 893	\$ 949	\$ 1003	
Back	\$ 442	\$ 503	\$ 564	\$ 625	\$ 700	\$ 777	\$ 853	\$ 929	\$ 1005	\$ 1082	\$ 1158	\$ 1234	\$ 1310	\$ 1386	

Model Number		Grade 9	Grade 10	Grade 11	Grade 12	Grade 13	Grade 14	Grade 15	Grade 16	Grade 17	Grade 18	Grade 19	Grade 20	Grade 21	Grade 22
Recharge Single Seats — Pages 234-235															
MLM1	Seat	\$ 503	\$ 572	\$ 641	\$ 711	\$ 797	\$ 884	\$ 971	\$ 1058	\$ 1144	\$ 1231	\$ 1317	\$ 1404	\$ 1491	\$ 1578
	Seat Welt	\$ 198	\$ 225	\$ 252	\$ 280	\$ 314	\$ 348	\$ 382	\$ 417	\$ 451	\$ 484	\$ 519	\$ 553	\$ 587	\$ 622
MLM2	Seat	\$ 503	\$ 572	\$ 641	\$ 711	\$ 797	\$ 884	\$ 971	\$ 1058	\$ 1144	\$ 1231	\$ 1317	\$ 1404	\$ 1491	\$ 1578
	Seat Welt	\$ 198	\$ 225	\$ 252	\$ 280	\$ 314	\$ 348	\$ 382	\$ 417	\$ 451	\$ 484	\$ 519	\$ 553	\$ 587	\$ 622
	Bolster	\$ 198	\$ 225	\$ 252	\$ 280	\$ 314	\$ 348	\$ 382	\$ 417	\$ 451	\$ 484	\$ 519	\$ 553	\$ 587	\$ 622
	Bolster Welt	\$ 152	\$ 174	\$ 195	\$ 215	\$ 241	\$ 268	\$ 294	\$ 320	\$ 347	\$ 373	\$ 399	\$ 426	\$ 452	\$ 478
MLM27	Seat	\$ 427	\$ 486	\$ 544	\$ 603	\$ 676	\$ 750	\$ 823	\$ 898	\$ 971	\$ 1045	\$ 1118	\$ 1192	\$ 1265	\$ 1338
	Seat Welt	\$ 121	\$ 139	\$ 155	\$ 173	\$ 193	\$ 214	\$ 235	\$ 257	\$ 277	\$ 298	\$ 320	\$ 341	\$ 361	\$ 382
	Bolster	\$ 350	\$ 398	\$ 447	\$ 495	\$ 555	\$ 616	\$ 676	\$ 737	\$ 797	\$ 857	\$ 918	\$ 978	\$ 1039	\$ 1099
	Bolster Welt	\$ 152	\$ 174	\$ 195	\$ 215	\$ 241	\$ 268	\$ 294	\$ 320	\$ 347	\$ 373	\$ 399	\$ 426	\$ 452	\$ 478
Recharge Double Seats — Pages 236-237															
MLM3	Seat	\$ 761	\$ 867	\$ 972	\$ 1076	\$ 1208	\$ 1339	\$ 1471	\$ 1602	\$ 1734	\$ 1864	\$ 1996	\$ 2127	\$ 2259	\$ 2390
	Seat Welt	\$ 198	\$ 225	\$ 252	\$ 280	\$ 314	\$ 348	\$ 382	\$ 417	\$ 451	\$ 484	\$ 519	\$ 553	\$ 587	\$ 622
MLM4	Seat	\$ 761	\$ 867	\$ 972	\$ 1076	\$ 1208	\$ 1339	\$ 1471	\$ 1602	\$ 1734	\$ 1864	\$ 1996	\$ 2127	\$ 2259	\$ 2390
	Seat Welt	\$ 198	\$ 225	\$ 252	\$ 280	\$ 314	\$ 348	\$ 382	\$ 417	\$ 451	\$ 484	\$ 519	\$ 553	\$ 587	\$ 622
	Bolster	\$ 350	\$ 398	\$ 447	\$ 495	\$ 555	\$ 616	\$ 676	\$ 737	\$ 797	\$ 857	\$ 918	\$ 978	\$ 1039	\$ 1099
	Bolster Welt	\$ 152	\$ 174	\$ 195	\$ 215	\$ 241	\$ 268	\$ 294	\$ 320	\$ 347	\$ 373	\$ 399	\$ 426	\$ 452	\$ 478
MLM9	Seat	\$ 761	\$ 867	\$ 972	\$ 1076	\$ 1208	\$ 1339	\$ 1471	\$ 1602	\$ 1734	\$ 1864	\$ 1996	\$ 2127	\$ 2259	\$ 2390
	Seat Welt	\$ 198	\$ 225	\$ 252	\$ 280	\$ 314	\$ 348	\$ 382	\$ 417	\$ 451	\$ 484	\$ 519	\$ 553	\$ 587	\$ 622
	Bolster	\$ 198	\$ 225	\$ 252	\$ 280	\$ 314	\$ 348	\$ 382	\$ 417	\$ 451	\$ 484	\$ 519	\$ 553	\$ 587	\$ 622
	Bolster Welt	\$ 152	\$ 174	\$ 195	\$ 215	\$ 241	\$ 268	\$ 294	\$ 320	\$ 347	\$ 373	\$ 399	\$ 426	\$ 452	\$ 478
MLM10	Seat	\$ 761	\$ 867	\$ 972	\$ 1076	\$ 1208	\$ 1339	\$ 1471	\$ 1602	\$ 1734	\$ 1864	\$ 1996	\$ 2127	\$ 2259	\$ 2390
	Seat Welt	\$ 198	\$ 225	\$ 252	\$ 280	\$ 314	\$ 348	\$ 382	\$ 417	\$ 451	\$ 484	\$ 519	\$ 553	\$ 587	\$ 622
	Bolster	\$ 198	\$ 225	\$ 252	\$ 280	\$ 314	\$ 348	\$ 382	\$ 417	\$ 451	\$ 484	\$ 519	\$ 553	\$ 587	\$ 622
	Bolster Welt	\$ 152	\$ 174	\$ 195	\$ 215	\$ 241	\$ 268	\$ 294	\$ 320	\$ 347	\$ 373	\$ 399	\$ 426	\$ 452	\$ 478
MLM11	Seat	\$ 761	\$ 867	\$ 972	\$ 1076	\$ 1208	\$ 1339	\$ 1471	\$ 1602	\$ 1734	\$ 1864	\$ 1996	\$ 2127	\$ 2259	\$ 2390
	Seat Welt	\$ 198	\$ 225	\$ 252	\$ 280	\$ 314	\$ 348	\$ 382	\$ 417	\$ 451	\$ 484	\$ 519	\$ 553	\$ 587	\$ 622
	Bolster	\$ 503	\$ 572	\$ 641	\$ 711	\$ 797	\$ 884	\$ 971	\$ 1058	\$ 1144	\$ 1231	\$ 1317	\$ 1404	\$ 1491	\$ 1578
	Bolster Welt	\$ 152	\$ 174	\$ 195	\$ 215	\$ 241	\$ 268	\$ 294	\$ 320	\$ 347	\$ 373	\$ 399	\$ 426	\$ 452	\$ 478
MLM13	Seat	\$ 761	\$ 867	\$ 972	\$ 1076	\$ 1208	\$ 1339	\$ 1471	\$ 1602	\$ 1734	\$ 1864	\$ 1996	\$ 2127	\$ 2259	\$ 2390
	Seat Welt	\$ 198	\$ 225	\$ 252	\$ 280	\$ 314	\$ 348	\$ 382	\$ 417	\$ 451	\$ 484	\$ 519	\$ 553	\$ 587	\$ 622
	Bolster	\$ 503	\$ 572	\$ 641	\$ 711	\$ 797	\$ 884	\$ 971	\$ 1058	\$ 1144	\$ 1231	\$ 1317	\$ 1404	\$ 1491	\$ 1578
	Bolster Welt	\$ 152	\$ 174	\$ 195	\$ 215	\$ 241	\$ 268	\$ 294	\$ 320	\$ 347	\$ 373	\$ 399	\$ 426	\$ 452	\$ 478
Recharge Double Seats — Pages 238-239															
MLM5	Seat	\$ 761	\$ 867	\$ 972	\$ 1076	\$ 1208	\$ 1339	\$ 1471	\$ 1602	\$ 1734	\$ 1864	\$ 1996	\$ 2127	\$ 2259	\$ 2390
	Seat Welt	\$ 198	\$ 225	\$ 252	\$ 280	\$ 314	\$ 348	\$ 382	\$ 417	\$ 451	\$ 484	\$ 519	\$ 553	\$ 587	\$ 622
	Bolster	\$ 350	\$ 398	\$ 447	\$ 495	\$ 555	\$ 616	\$ 676	\$ 737	\$ 797	\$ 857	\$ 918	\$ 978	\$ 1039	\$ 1099
	Bolster Welt	\$ 152	\$ 174	\$ 195	\$ 215	\$ 241	\$ 268	\$ 294	\$ 320	\$ 347	\$ 373	\$ 399	\$ 426	\$ 452	\$ 478
MLM6 &	Seat	\$ 761	\$ 867	\$ 972	\$ 1076	\$ 1208	\$ 1339	\$ 1471	\$ 1602	\$ 1734	\$ 1864	\$ 1996	\$ 2127	\$ 2259	\$ 2390
MLM7	Seat Welt	\$ 198	\$ 225	\$ 252	\$ 280	\$ 314	\$ 348	\$ 382	\$ 417	\$ 451	\$ 484	\$ 519	\$ 553	\$ 587	\$ 622
	Bolster	\$ 350	\$ 398	\$ 447	\$ 495	\$ 555	\$ 616	\$ 676	\$ 737	\$ 797	\$ 857	\$ 918	\$ 978	\$ 1039	\$ 1099
	Bolster Welt	\$ 152	\$ 174	\$ 195	\$ 215	\$ 241	\$ 268	\$ 294	\$ 320	\$ 347	\$ 373	\$ 399	\$ 426	\$ 452	\$ 478
MLM8	Seat	\$ 761	\$ 867	\$ 972	\$ 1076	\$ 1208	\$ 1339	\$ 1471	\$ 1602	\$ 1734	\$ 1864	\$ 1996	\$ 2127	\$ 2259	\$ 2390
	Seat Welt	\$ 198	\$ 225	\$ 252	\$ 280	\$ 314	\$ 348	\$ 382	\$ 417	\$ 451	\$ 484	\$ 519	\$ 553	\$ 587	\$ 622
	Bolster	\$ 350	\$ 398	\$ 447	\$ 495	\$ 555	\$ 616	\$ 676	\$ 737	\$ 797	\$ 857	\$ 918	\$ 978	\$ 1039	\$ 1099
	Bolster Welt	\$ 152	\$ 174	\$ 195	\$ 215	\$ 241	\$ 268	\$ 294	\$ 320	\$ 347	\$ 373	\$ 399	\$ 426	\$ 452	\$ 478
Recharge™ Poufs — Pages 234-235															
MLM20	Top	\$ 121	\$ 139	\$ 155	\$ 173	\$ 193	\$ 214	\$ 235	\$ 257	\$ 277	\$ 298	\$ 320	\$ 341	\$ 361	\$ 382
	Welt	\$ 152	\$ 174	\$ 195	\$ 215	\$ 241	\$ 268	\$ 294	\$ 320	\$ 347	\$ 373	\$ 399	\$ 426	\$ 452	\$ 478
	Side	\$ 198	\$ 225	\$ 252	\$ 280	\$ 314	\$ 348	\$ 382	\$ 417	\$ 451	\$ 484	\$ 519	\$ 553	\$ 587	\$ 622
MLM21	Top	\$ 121	\$ 139	\$ 155	\$ 173	\$ 193	\$ 214	\$ 235	\$ 257	\$ 277	\$ 298	\$ 320	\$ 341	\$ 361	\$ 382
	Welt	\$ 152	\$ 174	\$ 195	\$ 215	\$ 241	\$ 268	\$ 294	\$ 320	\$ 347	\$ 373	\$ 399	\$ 426	\$ 452	\$ 478
	Side	\$ 198	\$ 225	\$ 252	\$ 280	\$ 314	\$ 348	\$ 382	\$ 417	\$ 451	\$ 484	\$ 519	\$ 553	\$ 587	\$ 622

GRADES 9-22 PRICING

Model Number	Grade 9	Grade 10	Grade 11	Grade 12	Grade 13	Grade 14	Grade 15	Grade 16	Grade 17	Grade 18	Grade 19	Grade 20	Grade 21	Grade 22
Rise — Pages 250-257														
S922S2	\$ 4106	\$ 4217	\$ 4330	\$ 4441	\$ 4579	\$ 4719	\$ 4858	\$ 4998	\$ 5136	\$ 5276	\$ 5415	\$ 5554	\$ 5693	\$ 5833
S922S2P	\$ 4200	\$ 4311	\$ 4424	\$ 4535	\$ 4673	\$ 4813	\$ 4952	\$ 5092	\$ 5230	\$ 5370	\$ 5509	\$ 5648	\$ 5787	\$ 5927
S922S2IC	\$ 5494	\$ 5630	\$ 5768	\$ 5904	\$ 6074	\$ 6245	\$ 6416	\$ 6586	\$ 6758	\$ 6929	\$ 7099	\$ 7270	\$ 7440	\$ 7611
S922S2OC	\$ 5494	\$ 5630	\$ 5768	\$ 5904	\$ 6074	\$ 6245	\$ 6416	\$ 6586	\$ 6758	\$ 6929	\$ 7099	\$ 7270	\$ 7440	\$ 7611
S922S3	\$ 4472	\$ 4583	\$ 4696	\$ 4807	\$ 4945	\$ 5085	\$ 5224	\$ 5364	\$ 5502	\$ 5642	\$ 5781	\$ 5920	\$ 6059	\$ 6199
S922S3P	\$ 4567	\$ 4678	\$ 4791	\$ 4902	\$ 5040	\$ 5180	\$ 5319	\$ 5459	\$ 5597	\$ 5737	\$ 5876	\$ 6015	\$ 6154	\$ 6294
S922S2T, S922S2TP, S922S3T, and S922S3TP Upcharges														
Seat	\$ 495	\$ 563	\$ 632	\$ 700	\$ 785	\$ 870	\$ 956	\$ 1041	\$ 1126	\$ 1213	\$ 1298	\$ 1383	\$ 1468	\$ 1554
Side	\$ 305	\$ 347	\$ 389	\$ 431	\$ 483	\$ 536	\$ 588	\$ 640	\$ 694	\$ 746	\$ 798	\$ 851	\$ 903	\$ 956
S922S2TIC Upcharges														
Seat	\$ 647	\$ 736	\$ 826	\$ 915	\$ 1027	\$ 1138	\$ 1250	\$ 1362	\$ 1473	\$ 1585	\$ 1697	\$ 1809	\$ 1920	\$ 2031
Side	\$ 343	\$ 390	\$ 438	\$ 484	\$ 543	\$ 603	\$ 662	\$ 721	\$ 780	\$ 839	\$ 899	\$ 958	\$ 1016	\$ 1075
S922S2TOC Upcharges														
Seat	\$ 647	\$ 736	\$ 826	\$ 915	\$ 1027	\$ 1138	\$ 1250	\$ 1362	\$ 1473	\$ 1585	\$ 1697	\$ 1809	\$ 1920	\$ 2031
Side	\$ 343	\$ 390	\$ 438	\$ 484	\$ 543	\$ 603	\$ 662	\$ 721	\$ 780	\$ 839	\$ 899	\$ 958	\$ 1016	\$ 1075
S922S2LN	\$ 4782	\$ 4950	\$ 5118	\$ 5286	\$ 5496	\$ 5706	\$ 5917	\$ 6126	\$ 6336	\$ 6547	\$ 6757	\$ 6966	\$ 7177	\$ 7387
S922S2LP	\$ 4873	\$ 5041	\$ 5209	\$ 5377	\$ 5587	\$ 5797	\$ 6008	\$ 6217	\$ 6427	\$ 6638	\$ 6848	\$ 7057	\$ 7268	\$ 7478
S922SON	\$ 3266	\$ 3361	\$ 3456	\$ 3551	\$ 3668	\$ 3787	\$ 3905	\$ 4022	\$ 4141	\$ 4259	\$ 4378	\$ 4496	\$ 4614	\$ 4732
S922SOP	\$ 3357	\$ 3452	\$ 3547	\$ 3642	\$ 3759	\$ 3878	\$ 3996	\$ 4113	\$ 4232	\$ 4350	\$ 4469	\$ 4587	\$ 4705	\$ 4823
S922SOWN	\$ 3294	\$ 3393	\$ 3492	\$ 3593	\$ 3716	\$ 3841	\$ 3969	\$ 4096	\$ 4225	\$ 4356	\$ 4481	\$ 4613	\$ 4746	\$ 4881
S922SOWP	\$ 3385	\$ 3484	\$ 3583	\$ 3684	\$ 3807	\$ 3932	\$ 4060	\$ 4187	\$ 4316	\$ 4447	\$ 4572	\$ 4704	\$ 4837	\$ 4972
S922SWDN	\$ 3379	\$ 3485	\$ 3590	\$ 3694	\$ 3826	\$ 3957	\$ 4089	\$ 4220	\$ 4352	\$ 4482	\$ 4614	\$ 4745	\$ 4877	\$ 5008
S922SWDP	\$ 3470	\$ 3576	\$ 3681	\$ 3785	\$ 3917	\$ 4048	\$ 4180	\$ 4311	\$ 4443	\$ 4573	\$ 4705	\$ 4836	\$ 4968	\$ 5099
S922SWDWN	\$ 3192	\$ 3276	\$ 3360	\$ 3446	\$ 3551	\$ 3658	\$ 3768	\$ 3876	\$ 3983	\$ 4093	\$ 4205	\$ 4319	\$ 4433	\$ 4548
S922SWDWP	\$ 3283	\$ 3367	\$ 3451	\$ 3537	\$ 3642	\$ 3749	\$ 3859	\$ 3967	\$ 4074	\$ 4184	\$ 4296	\$ 4410	\$ 4524	\$ 4639
S922SHON	\$ 2733	\$ 2815	\$ 2896	\$ 2978	\$ 3082	\$ 3185	\$ 3289	\$ 3392	\$ 3490	\$ 3599	\$ 3708	\$ 3817	\$ 3926	\$ 4035
S922SHOWN	\$ 2692	\$ 2767	\$ 2842	\$ 2917	\$ 3012	\$ 3107	\$ 3202	\$ 3297	\$ 3387	\$ 3487	\$ 3587	\$ 3687	\$ 3787	\$ 3887
S922SAN	\$ 3385	\$ 3493	\$ 3601	\$ 3711	\$ 3845	\$ 3981	\$ 4121	\$ 4259	\$ 4400	\$ 4542	\$ 4679	\$ 4822	\$ 4967	\$ 5115
S922SAWN	\$ 3326	\$ 3425	\$ 3524	\$ 3625	\$ 3748	\$ 3873	\$ 4001	\$ 4128	\$ 4257	\$ 4388	\$ 4513	\$ 4645	\$ 4778	\$ 4913
S922SWN	\$ 3379	\$ 3485	\$ 3590	\$ 3694	\$ 3826	\$ 3957	\$ 4089	\$ 4220	\$ 4352	\$ 4482	\$ 4614	\$ 4745	\$ 4877	\$ 5008
S922LPN	\$ 595	\$ 637	\$ 679	\$ 721	\$ 773	\$ 826	\$ 878	\$ 930	\$ 984	\$ 1036	\$ 1088	\$ 1141	\$ 1193	\$ 1246
S922S2LTN	\$ 4287	\$ 4351	\$ 4416	\$ 4483	\$ 4564	\$ 4646	\$ 4729	\$ 4813	\$ 4899	\$ 4985	\$ 5074	\$ 5162	\$ 5251	\$ 5342
S922S2LTP	\$ 4379	\$ 4443	\$ 4508	\$ 4575	\$ 4656	\$ 4738	\$ 4821	\$ 4905	\$ 4991	\$ 5077	\$ 5166	\$ 5254	\$ 5343	\$ 5434
S922SOTN	\$ 3122	\$ 3163	\$ 3203	\$ 3246	\$ 3296	\$ 3347	\$ 3400	\$ 3453	\$ 3506	\$ 3561	\$ 3615	\$ 3671	\$ 3728	\$ 3784
S922SOTP	\$ 3214	\$ 3255	\$ 3295	\$ 3338	\$ 3388	\$ 3439	\$ 3492	\$ 3545	\$ 3598	\$ 3653	\$ 3707	\$ 3763	\$ 3820	\$ 3876
S922SOTWP Upcharges														
Seat	\$ 457	\$ 527	\$ 597	\$ 668	\$ 754	\$ 841	\$ 930	\$ 1021	\$ 1112	\$ 1204	\$ 1298	\$ 1393	\$ 1489	\$ 1586
Side	\$ 246	\$ 284	\$ 321	\$ 360	\$ 406	\$ 453	\$ 501	\$ 550	\$ 599	\$ 649	\$ 699	\$ 750	\$ 802	\$ 854
S922SOTWN Upcharges														
Seat	\$ 457	\$ 527	\$ 597	\$ 668	\$ 754	\$ 841	\$ 930	\$ 1021	\$ 1112	\$ 1204	\$ 1298	\$ 1393	\$ 1489	\$ 1586
Side	\$ 246	\$ 284	\$ 321	\$ 360	\$ 406	\$ 453	\$ 501	\$ 550	\$ 599	\$ 649	\$ 699	\$ 750	\$ 802	\$ 854
S922SHOTN	\$ 2619	\$ 2643	\$ 2666	\$ 2691	\$ 2720	\$ 2749	\$ 2779	\$ 2810	\$ 2840	\$ 2872	\$ 2904	\$ 2936	\$ 2970	\$ 3003
S922SHOTWN Upcharges														
Seat	\$ 390	\$ 445	\$ 500	\$ 558	\$ 627	\$ 696	\$ 767	\$ 838	\$ 911	\$ 985	\$ 1058	\$ 1138	\$ 1215	\$ 1292
Side	\$ 151	\$ 173	\$ 194	\$ 217	\$ 244	\$ 270	\$ 298	\$ 326	\$ 354	\$ 383	\$ 412	\$ 442	\$ 473	\$ 503
S922SATN	\$ 3127	\$ 3163	\$ 3198	\$ 3256	\$ 3298	\$ 3344	\$ 3390	\$ 3437	\$ 3484	\$ 3530	\$ 3579	\$ 3630	\$ 3680	\$ 3730
S922SWTN	\$ 3377	\$ 3445	\$ 3445	\$ 3516	\$ 3674	\$ 3764	\$ 3852	\$ 3942	\$ 4033	\$ 4124	\$ 4217	\$ 4313	\$ 4409	\$ 4507
S922SATWN Upcharges														
Seat	\$ 562	\$ 644	\$ 727	\$ 864	\$ 965	\$ 1073	\$ 1181	\$ 1290	\$ 1402	\$ 1512	\$ 1627	\$ 1746	\$ 1865	\$ 1984
Side	\$ 218	\$ 251	\$ 283	\$ 336	\$ 375	\$ 417	\$ 459	\$ 502	\$ 545	\$ 588	\$ 633	\$ 679	\$ 725	\$ 771

Model Number		Grade 9	Grade 10	Grade 11	Grade 12	Grade 13	Grade 14	Grade 15	Grade 16	Grade 17	Grade 18	Grade 19	Grade 20	Grade 21	Grade 22
Retreat — Pages 264-267															
VERWNO	Body	\$ 610	\$ 694	\$ 778	\$ 862	\$ 966	\$ 1072	\$ 1177	\$ 1281	\$ 1387	\$ 1492	\$ 1597	\$ 1702	\$ 1807	\$ 1912
	Seat	\$ 152	\$ 174	\$ 195	\$ 215	\$ 241	\$ 268	\$ 294	\$ 320	\$ 347	\$ 373	\$ 399	\$ 426	\$ 452	\$ 478
VERHNO	Body	\$ 457	\$ 520	\$ 583	\$ 646	\$ 725	\$ 804	\$ 882	\$ 961	\$ 1040	\$ 1119	\$ 1197	\$ 1277	\$ 1355	\$ 1434
	Seat	\$ 152	\$ 174	\$ 195	\$ 215	\$ 241	\$ 268	\$ 294	\$ 320	\$ 347	\$ 373	\$ 399	\$ 426	\$ 452	\$ 478
VERLNO	Body	\$ 411	\$ 468	\$ 525	\$ 581	\$ 652	\$ 723	\$ 794	\$ 865	\$ 936	\$ 1007	\$ 1077	\$ 1148	\$ 1220	\$ 1291
	Seat	\$ 137	\$ 156	\$ 175	\$ 193	\$ 217	\$ 241	\$ 264	\$ 288	\$ 312	\$ 335	\$ 359	\$ 383	\$ 407	\$ 430
VERONO	Body	\$ 228	\$ 260	\$ 292	\$ 323	\$ 362	\$ 402	\$ 441	\$ 480	\$ 520	\$ 560	\$ 599	\$ 638	\$ 677	\$ 717
	Seat	\$ 152	\$ 174	\$ 195	\$ 215	\$ 241	\$ 268	\$ 294	\$ 320	\$ 347	\$ 373	\$ 399	\$ 426	\$ 452	\$ 478
RETECMS	Body/Seat	\$ 610	\$ 694	\$ 778	\$ 862	\$ 966	\$ 1072	\$ 1177	\$ 1281	\$ 1387	\$ 1492	\$ 1597	\$ 1702	\$ 1807	\$ 1912
RETECLS	Body/Seat	\$ 457	\$ 520	\$ 583	\$ 646	\$ 725	\$ 804	\$ 882	\$ 961	\$ 1040	\$ 1119	\$ 1197	\$ 1277	\$ 1355	\$ 1434
RETECMM	Body	\$ 457	\$ 520	\$ 583	\$ 646	\$ 725	\$ 804	\$ 882	\$ 961	\$ 1040	\$ 1119	\$ 1197	\$ 1277	\$ 1355	\$ 1434
	Seat	\$ 152	\$ 174	\$ 195	\$ 215	\$ 241	\$ 268	\$ 294	\$ 320	\$ 347	\$ 373	\$ 399	\$ 426	\$ 452	\$ 478
RETECLM	Body	\$ 305	\$ 347	\$ 389	\$ 431	\$ 483	\$ 536	\$ 588	\$ 640	\$ 694	\$ 746	\$ 798	\$ 851	\$ 903	\$ 956
	Seat	\$ 152	\$ 174	\$ 195	\$ 215	\$ 241	\$ 268	\$ 294	\$ 320	\$ 347	\$ 373	\$ 399	\$ 426	\$ 452	\$ 478
PARALLEL CLUB CHAIR — Pages 272-273															
PSCN		\$ 4760	\$ 4855	\$ 4950	\$ 5045	\$ 5162	\$ 5281	\$ 5399	\$ 5516	\$ 5635	\$ 5753	\$ 5872	\$ 5990	\$ 6108	\$ 6226
PSCC		\$ 5182	\$ 5277	\$ 5372	\$ 5467	\$ 5584	\$ 5703	\$ 5821	\$ 5938	\$ 6057	\$ 6175	\$ 6294	\$ 6412	\$ 6530	\$ 6648
PARALLEL CLUB PLUS LOUNGE — Pages 272-273															
PSCPN		\$ 5143	\$ 5251	\$ 5360	\$ 5468	\$ 5605	\$ 5740	\$ 5875	\$ 6011	\$ 6146	\$ 6283	\$ 6418	\$ 6553	\$ 6689	\$ 6824
PSCPC		\$ 5566	\$ 5674	\$ 5783	\$ 5891	\$ 6028	\$ 6163	\$ 6298	\$ 6434	\$ 6569	\$ 6706	\$ 6841	\$ 6976	\$ 7112	\$ 7247
PARALLEL SOFA — Pages 272-273															
PSDSN		\$ 8056	\$ 8216	\$ 8377	\$ 8536	\$ 8736	\$ 8936	\$ 9135	\$ 9336	\$ 9535	\$ 9735	\$ 9935	\$ 10135	\$ 10334	\$ 10535
PSDSC		\$ 8619	\$ 8779	\$ 8940	\$ 9099	\$ 9299	\$ 9499	\$ 9698	\$ 9899	\$ 10098	\$ 10298	\$ 10498	\$ 10698	\$ 10897	\$ 11098
Two-Thirds — Pages 280-285															
EPR18S		\$ 1047	\$ 1081	\$ 1116	\$ 1149	\$ 1192	\$ 1236	\$ 1278	\$ 1321	\$ 1364	\$ 1407	\$ 1449	\$ 1492	\$ 1535	\$ 1578
EPW18S		\$ 1120	\$ 1154	\$ 1189	\$ 1222	\$ 1265	\$ 1309	\$ 1351	\$ 1394	\$ 1437	\$ 1480	\$ 1522	\$ 1565	\$ 1608	\$ 1651
EPP1722S		\$ 1298	\$ 1337	\$ 1375	\$ 1414	\$ 1463	\$ 1511	\$ 1560	\$ 1608	\$ 1657	\$ 1705	\$ 1754	\$ 1802	\$ 1851	\$ 1899
EPP1820S		\$ 1357	\$ 1394	\$ 1430	\$ 1467	\$ 1513	\$ 1558	\$ 1604	\$ 1649	\$ 1695	\$ 1741	\$ 1787	\$ 1833	\$ 1878	\$ 1924
EPP2128S		\$ 1480	\$ 1522	\$ 1566	\$ 1609	\$ 1664	\$ 1718	\$ 1772	\$ 1826	\$ 1881	\$ 1935	\$ 1989	\$ 2043	\$ 2098	\$ 2152
EPB1421S		\$ 1252	\$ 1305	\$ 1358	\$ 1410	\$ 1475	\$ 1541	\$ 1607	\$ 1673	\$ 1738	\$ 1803	\$ 1870	\$ 1935	\$ 2001	\$ 2066
EPB2121S		\$ 1325	\$ 1378	\$ 1431	\$ 1483	\$ 1548	\$ 1614	\$ 1680	\$ 1746	\$ 1811	\$ 1876	\$ 1943	\$ 2008	\$ 2074	\$ 2139
EPB2128S		\$ 1497	\$ 1563	\$ 1629	\$ 1696	\$ 1778	\$ 1861	\$ 1944	\$ 2027	\$ 2110	\$ 2193	\$ 2274	\$ 2357	\$ 2440	\$ 2523
EPB2142S		\$ 1863	\$ 1929	\$ 1995	\$ 2062	\$ 2144	\$ 2227	\$ 2310	\$ 2393	\$ 2476	\$ 2559	\$ 2640	\$ 2723	\$ 2806	\$ 2889
EPR18M	1/3 Upholstery	\$ 1041	\$ 1059	\$ 1077	\$ 1096	\$ 1119	\$ 1142	\$ 1165	\$ 1188	\$ 1210	\$ 1233	\$ 1255	\$ 1278	\$ 1301	\$ 1324
	2/3 Upholstery	\$ 1123	\$ 1154	\$ 1183	\$ 1213	\$ 1250	\$ 1287	\$ 1324	\$ 1361	\$ 1398	\$ 1435	\$ 1473	\$ 1510	\$ 1547	\$ 1584
EPW18M	1/3 Upholstery	\$ 1113	\$ 1131	\$ 1149	\$ 1168	\$ 1191	\$ 1214	\$ 1237	\$ 1260	\$ 1282	\$ 1305	\$ 1327	\$ 1350	\$ 1373	\$ 1396
	2/3 Upholstery	\$ 1195	\$ 1226	\$ 1255	\$ 1285	\$ 1322	\$ 1359	\$ 1396	\$ 1433	\$ 1470	\$ 1507	\$ 1545	\$ 1582	\$ 1619	\$ 1656
EPP1722M	1/3 Upholstery	\$ 1258	\$ 1276	\$ 1294	\$ 1313	\$ 1336	\$ 1359	\$ 1382	\$ 1405	\$ 1427	\$ 1450	\$ 1472	\$ 1495	\$ 1518	\$ 1541
	2/3 Upholstery	\$ 1374	\$ 1408	\$ 1443	\$ 1476	\$ 1519	\$ 1563	\$ 1605	\$ 1648	\$ 1691	\$ 1734	\$ 1776	\$ 1819	\$ 1862	\$ 1905
EPP1820M	1/3 Upholstery	\$ 1332	\$ 1350	\$ 1368	\$ 1387	\$ 1410	\$ 1433	\$ 1456	\$ 1479	\$ 1501	\$ 1524	\$ 1546	\$ 1569	\$ 1592	\$ 1615
	2/3 Upholstery	\$ 1448	\$ 1482	\$ 1517	\$ 1550	\$ 1593	\$ 1637	\$ 1679	\$ 1722	\$ 1765	\$ 1808	\$ 1850	\$ 1893	\$ 1936	\$ 1979
EPP2128M	1/3 Upholstery	\$ 1406	\$ 1424	\$ 1442	\$ 1461	\$ 1484	\$ 1507	\$ 1530	\$ 1553	\$ 1575	\$ 1598	\$ 1620	\$ 1643	\$ 1666	\$ 1689
	2/3 Upholstery	\$ 1522	\$ 1556	\$ 1591	\$ 1624	\$ 1667	\$ 1711	\$ 1753	\$ 1796	\$ 1839	\$ 1882	\$ 1924	\$ 1967	\$ 2010	\$ 2053
EPB1421M	1/3 Upholstery	\$ 1146	\$ 1169	\$ 1192	\$ 1215	\$ 1243	\$ 1272	\$ 1300	\$ 1329	\$ 1358	\$ 1386	\$ 1414	\$ 1443	\$ 1471	\$ 1500
	2/3 Upholstery	\$ 1245	\$ 1282	\$ 1318	\$ 1355	\$ 1401	\$ 1446	\$ 1492	\$ 1537	\$ 1583	\$ 1629	\$ 1675	\$ 1721	\$ 1766	\$ 1812
EPB2121M	1/3 Upholstery	\$ 1218	\$ 1241	\$ 1264	\$ 1287	\$ 1315	\$ 1344	\$ 1372	\$ 1401	\$ 1430	\$ 1458	\$ 1486	\$ 1515	\$ 1543	\$ 1572
	2/3 Upholstery	\$ 1317	\$ 1354	\$ 1390	\$ 1427	\$ 1473	\$ 1518	\$ 1564	\$ 1609	\$ 1655	\$ 1701	\$ 1747	\$ 1793	\$ 1838	\$ 1884
EPB2128M	1/3 Upholstery	\$ 1291	\$ 1314	\$ 1337	\$ 1360	\$ 1388	\$ 1417	\$ 1445	\$ 1474	\$ 1503	\$ 1531	\$ 1559	\$ 1588	\$ 1616	\$ 1645
	2/3 Upholstery	\$ 1390	\$ 1427	\$ 1463	\$ 1500	\$ 1546	\$ 1591	\$ 1637	\$ 1682	\$ 1728	\$ 1774	\$ 1820	\$ 1866	\$ 1911	\$ 1957
EPB1442M	1/3 Upholstery	\$ 1647	\$ 1684	\$ 1720	\$ 1757	\$ 1803	\$ 1848	\$ 1894	\$ 1939	\$ 1985	\$ 2031	\$ 2077	\$ 2123	\$ 2168	\$ 2214
	2/3 Upholstery	\$ 1763	\$ 1816	\$ 1869	\$ 1921	\$ 1986	\$ 2052	\$ 2118	\$ 2184	\$ 2249	\$ 2314	\$ 2381	\$ 2446	\$ 2512	\$ 2577
EPB2142M	1/3 Upholstery	\$ 1756	\$ 1793	\$ 1829	\$ 1866	\$ 1912	\$ 1957	\$ 2003	\$ 2048	\$ 2094	\$ 2140	\$ 2186	\$ 2232	\$ 2277	\$ 2323
	2/3 Upholstery	\$ 1872	\$ 1925	\$ 1978	\$ 2030	\$ 2095	\$ 2161	\$ 2227	\$ 2293	\$ 2358	\$ 2423	\$ 2490	\$ 2555	\$ 2621	\$ 2686

Model Number	Grade 9	Grade 10	Grade 11	Grade 12	Grade 13	Grade 14	Grade 15	Grade 16	Grade 17	Grade 18	Grade 19	Grade 20	Grade 21	Grade 22
VICINITY LOUNGE — Pages 292-293														
CLG-UGANO	\$ 2980	\$ 3045	\$ 3110	\$ 3175	\$ 3256	\$ 3338	\$ 3418	\$ 3499	\$ 3581	\$ 3662	\$ 3742	\$ 3825	\$ 3905	\$ 3987
CLG-CGANO	\$ 3455	\$ 3565	\$ 3673	\$ 3780	\$ 3916	\$ 4051	\$ 4187	\$ 4322	\$ 4458	\$ 4591	\$ 4727	\$ 4862	\$ 4998	\$ 5133
CLG-WGANO	\$ 3834	\$ 3877	\$ 3920	\$ 3963	\$ 4017	\$ 4072	\$ 4125	\$ 4179	\$ 4234	\$ 4288	\$ 4341	\$ 4396	\$ 4450	\$ 4504
CLR-UGANO	\$ 3579	\$ 3644	\$ 3709	\$ 3774	\$ 3855	\$ 3937	\$ 4017	\$ 4098	\$ 4180	\$ 4261	\$ 4341	\$ 4424	\$ 4504	\$ 4586
CLR-CGANO	\$ 4046	\$ 4156	\$ 4264	\$ 4371	\$ 4507	\$ 4642	\$ 4778	\$ 4913	\$ 5049	\$ 5182	\$ 5318	\$ 5453	\$ 5589	\$ 5724
CLR-WGANO	\$ 4016	\$ 4059	\$ 4102	\$ 4145	\$ 4199	\$ 4254	\$ 4307	\$ 4361	\$ 4416	\$ 4470	\$ 4523	\$ 4578	\$ 4632	\$ 4686
CO HO™ — Page 295														
CHULNO	\$ 1978	\$ 2008	\$ 2039	\$ 2069	\$ 2107	\$ 2145	\$ 2182	\$ 2220	\$ 2259	\$ 2297	\$ 2334	\$ 2372	\$ 2410	\$ 2448
LINGER — Page 299														
S924SS	\$ 4043	\$ 4123	\$ 4204	\$ 4285	\$ 4387	\$ 4488	\$ 4591	\$ 4692	\$ 4792	\$ 4894	\$ 4995	\$ 5096	\$ 5198	\$ 5299
S924ST Upcharges														
Seat	\$ 393	\$ 446	\$ 501	\$ 555	\$ 623	\$ 691	\$ 758	\$ 826	\$ 894	\$ 960	\$ 1028	\$ 1095	\$ 1164	\$ 1231
Side	\$ 196	\$ 223	\$ 250	\$ 278	\$ 312	\$ 346	\$ 380	\$ 414	\$ 446	\$ 480	\$ 514	\$ 547	\$ 582	\$ 616

Model Number	Base Model List Price	Option Upcharges — Add to Base Model Price											
		Grade 7	Grade 8	Grade 9	Grade 10	Grade 11	Grade 12	Grade 13	Grade 14	Grade 15	Grade 16	Grade 17	Grade 18
Options													
Reflect — Page 303													
GAWRP (De-emphasized)	\$8814												
Seat/Back Upholstery		\$ 369	\$ 440	\$ 510	\$ 580	\$ 651	\$ 721	\$ 809	\$ 897	\$ 985	\$ 1073	\$ 1160	\$ 1250
Upper Shell Upholstery		\$ 569	\$ 677	\$ 784	\$ 894	\$ 1002	\$ 1109	\$ 1245	\$ 1380	\$ 1516	\$ 1651	\$ 1787	\$ 1920
Clubhouse — Pages 312-315													
GA56MSE	\$21307												
Frontboard/Backboard Upholstery		\$ 743	\$ 890	\$ 1040	\$ 1188	\$ 1337	\$ 1559	\$ 1781	\$ 2005	\$ 2228	\$ 2451	\$ 2673	\$ 2896
Seating Upholstery		\$ 1807	\$ 2169	\$ 2529	\$ 2891	\$ 3252	\$ 3795	\$ 4337	\$ 4878	\$ 5421	\$ 5962	\$ 6505	\$ 7047
Seating Side Upholstery		\$ 421	\$ 505	\$ 590	\$ 672	\$ 758	\$ 883	\$ 1009	\$ 1136	\$ 1262	\$ 1388	\$ 1515	\$ 1641
GA70MCOUHP	\$28384												
GA70MCOUNP	\$28382												
Frontboard/Backboard Upholstery		\$ 743	\$ 890	\$ 1040	\$ 1188	\$ 1337	\$ 1559	\$ 1781	\$ 2005	\$ 2228	\$ 2451	\$ 2673	\$ 2896
Seating Upholstery		\$ 1733	\$ 2079	\$ 2426	\$ 2772	\$ 3118	\$ 3638	\$ 4159	\$ 4678	\$ 5199	\$ 5718	\$ 6237	\$ 6757
Seating Side Upholstery		\$ 1485	\$ 1781	\$ 2079	\$ 2376	\$ 2673	\$ 3118	\$ 3564	\$ 4010	\$ 4456	\$ 4901	\$ 5346	\$ 5793
GA70MCOLHP	\$29065												
GA70MCOLNP	\$29062												
Frontboard/Backboard Upholstery		\$ 743	\$ 890	\$ 1040	\$ 1188	\$ 1337	\$ 1559	\$ 1781	\$ 2005	\$ 2228	\$ 2451	\$ 2673	\$ 2896
Seating Upholstery		\$ 1733	\$ 2079	\$ 2426	\$ 2772	\$ 3118	\$ 3638	\$ 4159	\$ 4678	\$ 5199	\$ 5718	\$ 6237	\$ 6757
Seating Side Upholstery		\$ 1485	\$ 1781	\$ 2079	\$ 2376	\$ 2673	\$ 3118	\$ 3564	\$ 4010	\$ 4456	\$ 4901	\$ 5346	\$ 5793
GA70MSTHR	\$27449												
GA70MSTHL	\$27449												
GA70MSTNP	\$27447												
Frontboard/Backboard/Storage Upholstery		\$ 867	\$ 1040	\$ 1214	\$ 1385	\$ 1559	\$ 1818	\$ 2079	\$ 2339	\$ 2600	\$ 2860	\$ 3118	\$ 3379
Seating Upholstery		\$ 1807	\$ 2169	\$ 2529	\$ 2891	\$ 3252	\$ 3795	\$ 4337	\$ 4878	\$ 5421	\$ 5962	\$ 6505	\$ 7047
Seating Side Upholstery		\$ 421	\$ 505	\$ 590	\$ 672	\$ 758	\$ 883	\$ 1009	\$ 1136	\$ 1262	\$ 1388	\$ 1515	\$ 1641
GA70MMCU	\$31476												
Frontboard/Backboard Upholstery		\$ 743	\$ 890	\$ 1040	\$ 1188	\$ 1337	\$ 1559	\$ 1781	\$ 2005	\$ 2228	\$ 2451	\$ 2673	\$ 2896
Seating Upholstery		\$ 1807	\$ 2169	\$ 2529	\$ 2891	\$ 3252	\$ 3795	\$ 4337	\$ 4878	\$ 5421	\$ 5962	\$ 6505	\$ 7047
Seating Side Upholstery		\$ 1163	\$ 1396	\$ 1629	\$ 1862	\$ 2093	\$ 2443	\$ 2792	\$ 3141	\$ 3489	\$ 3839	\$ 4188	\$ 4537
GA70MMCL	\$32156												
Frontboard/Backboard Upholstery		\$ 743	\$ 890	\$ 1040	\$ 1188	\$ 1337	\$ 1559	\$ 1781	\$ 2005	\$ 2228	\$ 2451	\$ 2673	\$ 2896
Seating Upholstery		\$ 1807	\$ 2169	\$ 2529	\$ 2891	\$ 3252	\$ 3795	\$ 4337	\$ 4878	\$ 5421	\$ 5962	\$ 6505	\$ 7047
Seating Side Upholstery		\$ 1163	\$ 1396	\$ 1629	\$ 1862	\$ 2093	\$ 2443	\$ 2792	\$ 3141	\$ 3489	\$ 3839	\$ 4188	\$ 4537
GA84MSE	\$29626												
Frontboard/Backboard Upholstery		\$ 743	\$ 890	\$ 1040	\$ 1188	\$ 1337	\$ 1559	\$ 1781	\$ 2005	\$ 2228	\$ 2451	\$ 2673	\$ 2896
Seating Upholstery		\$ 2600	\$ 3118	\$ 3638	\$ 4159	\$ 4678	\$ 5458	\$ 6237	\$ 7017	\$ 7799	\$ 8577	\$ 9356	\$ 10137
Seating Side Upholstery		\$ 1115	\$ 1337	\$ 1559	\$ 1781	\$ 2005	\$ 2339	\$ 2673	\$ 3008	\$ 3342	\$ 3676	\$ 4010	\$ 4345
GA84MMW	\$34534												
Frontboard/Backboard Upholstery		\$ 743	\$ 890	\$ 1040	\$ 1188	\$ 1337	\$ 1559	\$ 1781	\$ 2005	\$ 2228	\$ 2451	\$ 2673	\$ 2896
Seating Upholstery		\$ 2600	\$ 3118	\$ 3638	\$ 4159	\$ 4678	\$ 5458	\$ 6237	\$ 7017	\$ 7799	\$ 8577	\$ 9356	\$ 10137
Seating Side Upholstery		\$ 1115	\$ 1337	\$ 1559	\$ 1781	\$ 2005	\$ 2339	\$ 2673	\$ 3008	\$ 3342	\$ 3676	\$ 4010	\$ 4345
GA84MSTHR	\$33257												
GA84MSTHL	\$33257												
GA84MSTNP	\$33255												
Frontboard/Backboard/Storage Upholstery		\$ 867	\$ 1040	\$ 1214	\$ 1385	\$ 1559	\$ 1818	\$ 2079	\$ 2339	\$ 2600	\$ 2860	\$ 3118	\$ 3379
Seating Upholstery		\$ 1658	\$ 1990	\$ 2323	\$ 2653	\$ 2985	\$ 3483	\$ 3979	\$ 4477	\$ 4974	\$ 5472	\$ 5969	\$ 6469
Seating Side Upholstery		\$ 1559	\$ 1871	\$ 2183	\$ 2494	\$ 2806	\$ 3275	\$ 3741	\$ 4211	\$ 4678	\$ 5146	\$ 5614	\$ 6082

Model Number	Base Model List Price	Option Upcharges — Add to Base Model Price											
		Grade 7	Grade 8	Grade 9	Grade 10	Grade 11	Grade 12	Grade 13	Grade 14	Grade 15	Grade 16	Grade 17	Grade 18
Options													
GA56HSE	\$24492												
Frontboard/Backboard Upholstery		\$ 743	\$ 890	\$ 1040	\$ 1188	\$ 1337	\$ 1559	\$ 1781	\$ 2005	\$ 2228	\$ 2451	\$ 2673	\$ 2896
Seating Upholstery		\$ 1807	\$ 2169	\$ 2529	\$ 2891	\$ 3252	\$ 3795	\$ 4337	\$ 4878	\$ 5421	\$ 5962	\$ 6505	\$ 7047
Seating Side Upholstery		\$ 421	\$ 505	\$ 590	\$ 672	\$ 758	\$ 883	\$ 1009	\$ 1136	\$ 1262	\$ 1388	\$ 1515	\$ 1641
GA70HCOUHP	\$31630												
GA70HCOUNP	\$31628												
Frontboard/Backboard Upholstery		\$ 743	\$ 890	\$ 1040	\$ 1188	\$ 1337	\$ 1559	\$ 1781	\$ 2005	\$ 2228	\$ 2451	\$ 2673	\$ 2896
Seating Upholstery		\$ 1733	\$ 2079	\$ 2426	\$ 2772	\$ 3118	\$ 3638	\$ 4159	\$ 4678	\$ 5199	\$ 5718	\$ 6237	\$ 6757
Seating Side Upholstery		\$ 1485	\$ 1781	\$ 2079	\$ 2376	\$ 2673	\$ 3118	\$ 3564	\$ 4010	\$ 4456	\$ 4901	\$ 5346	\$ 5793
GA70HCOLHP	\$32311												
GA70HCOLNP	\$32308												
Frontboard/Backboard Upholstery		\$ 743	\$ 890	\$ 1040	\$ 1188	\$ 1337	\$ 1559	\$ 1781	\$ 2005	\$ 2228	\$ 2451	\$ 2673	\$ 2896
Seating Upholstery		\$ 1733	\$ 2079	\$ 2426	\$ 2772	\$ 3118	\$ 3638	\$ 4159	\$ 4678	\$ 5199	\$ 5718	\$ 6237	\$ 6757
Seating Side Upholstery		\$ 1485	\$ 1781	\$ 2079	\$ 2376	\$ 2673	\$ 3118	\$ 3564	\$ 4010	\$ 4456	\$ 4901	\$ 5346	\$ 5793
GA70HSTHR	\$29078												
GA70HSTHL	\$29078												
GA70HSTNP	\$29066												
Frontboard/Backboard/Storage Upholstery		\$ 867	\$ 1040	\$ 1214	\$ 1385	\$ 1559	\$ 1818	\$ 2079	\$ 2339	\$ 2600	\$ 2860	\$ 3118	\$ 3379
Seating Upholstery		\$ 1807	\$ 2169	\$ 2529	\$ 2891	\$ 3252	\$ 3795	\$ 4337	\$ 4878	\$ 5421	\$ 5962	\$ 6505	\$ 7047
Seating Side Upholstery		\$ 421	\$ 505	\$ 590	\$ 672	\$ 758	\$ 883	\$ 1009	\$ 1136	\$ 1262	\$ 1388	\$ 1515	\$ 1641
GA70HMCU	\$34583												
Frontboard/Backboard Upholstery		\$ 743	\$ 890	\$ 1040	\$ 1188	\$ 1337	\$ 1559	\$ 1781	\$ 2005	\$ 2228	\$ 2451	\$ 2673	\$ 2896
Seating Upholstery		\$ 1807	\$ 2169	\$ 2529	\$ 2891	\$ 3252	\$ 3795	\$ 4337	\$ 4878	\$ 5421	\$ 5962	\$ 6505	\$ 7047
Seating Side Upholstery		\$ 1163	\$ 1396	\$ 1629	\$ 1862	\$ 2093	\$ 2443	\$ 2792	\$ 3141	\$ 3489	\$ 3839	\$ 4188	\$ 4537
GA70HMCL	\$35263												
Frontboard/Backboard Upholstery		\$ 743	\$ 890	\$ 1040	\$ 1188	\$ 1337	\$ 1559	\$ 1781	\$ 2005	\$ 2228	\$ 2451	\$ 2673	\$ 2896
Seating Upholstery		\$ 1807	\$ 2169	\$ 2529	\$ 2891	\$ 3252	\$ 3795	\$ 4337	\$ 4878	\$ 5421	\$ 5962	\$ 6505	\$ 7047
Seating Side Upholstery		\$ 1163	\$ 1396	\$ 1629	\$ 1862	\$ 2093	\$ 2443	\$ 2792	\$ 3141	\$ 3489	\$ 3839	\$ 4188	\$ 4537
GA84HSE	\$33024												
Frontboard/Backboard Upholstery		\$ 743	\$ 890	\$ 1040	\$ 1188	\$ 1337	\$ 1559	\$ 1781	\$ 2005	\$ 2228	\$ 2451	\$ 2673	\$ 2896
Seating Upholstery		\$ 2600	\$ 3118	\$ 3638	\$ 4159	\$ 4678	\$ 5458	\$ 6237	\$ 7017	\$ 7799	\$ 8577	\$ 9356	\$ 10137
Seating Side Upholstery		\$ 1115	\$ 1337	\$ 1559	\$ 1781	\$ 2005	\$ 2339	\$ 2673	\$ 3008	\$ 3342	\$ 3676	\$ 4010	\$ 4345
GA84HMW	\$37793												
Frontboard/Backboard Upholstery		\$ 743	\$ 890	\$ 1040	\$ 1188	\$ 1337	\$ 1559	\$ 1781	\$ 2005	\$ 2228	\$ 2451	\$ 2673	\$ 2896
Seating Upholstery		\$ 2600	\$ 3118	\$ 3638	\$ 4159	\$ 4678	\$ 5458	\$ 6237	\$ 7017	\$ 7799	\$ 8577	\$ 9356	\$ 10137
Seating Side Upholstery		\$ 1115	\$ 1337	\$ 1559	\$ 1781	\$ 2005	\$ 2339	\$ 2673	\$ 3008	\$ 3342	\$ 3676	\$ 4010	\$ 4345
GA84HSTHR	\$35038												
GA84HSTHL	\$35038												
GA84HSTNP	\$35036												
Frontboard/Backboard/Storage Upholstery		\$ 867	\$ 1040	\$ 1214	\$ 1385	\$ 1559	\$ 1818	\$ 2079	\$ 2339	\$ 2600	\$ 2860	\$ 3118	\$ 3379
Seating Upholstery		\$ 1658	\$ 1990	\$ 2323	\$ 2653	\$ 2985	\$ 3483	\$ 3979	\$ 4477	\$ 4974	\$ 5472	\$ 5969	\$ 6469
Seating Side Upholstery		\$ 1559	\$ 1871	\$ 2183	\$ 2494	\$ 2806	\$ 3275	\$ 3741	\$ 4211	\$ 4678	\$ 5146	\$ 5614	\$ 6082

Belong™ pages 327-328

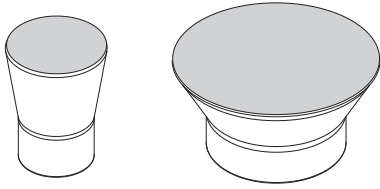

Parallel™ page 329

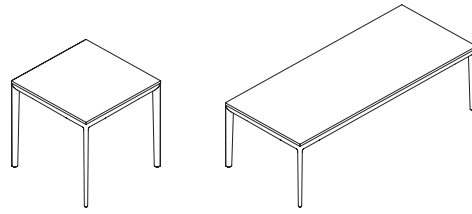

Rise™ pages 330-331

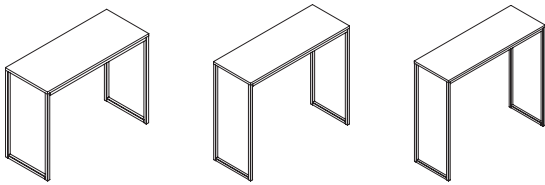

Two Thirds™ pages 332-335

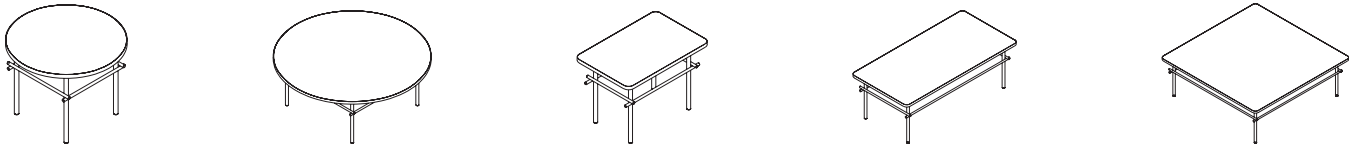

Park™ pages 336-337

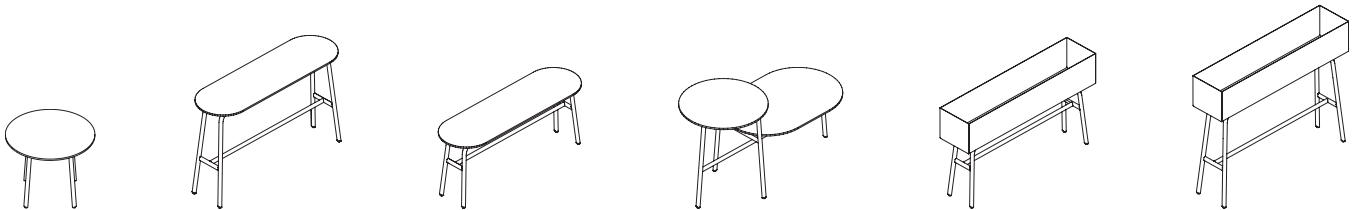

**TOP & BASE
PAINT FINISHES**

GRADE P1

Black	P27
Black	P71
Brownstone	P7D
Bungalow	P7C
Cinder	P7Q
Cove	P096
Designer White	PJW
Dune	P094
Flint	P02
Fossil	P28
Harbor	P097
Loft	P7B
Muslin	P4J
Pebble	P8R
Pewter	P8D
Sage	P095
Salt	P8C
Titanium	P8T/T

GRADE P2

Champagne Metallic	PR5
Designer White High Gloss 65	P8W
Gunmetal Metallic	PR3
Matte Gold	P8G
Night Bronze	P8B
Platinum Metallic	PR2
Pyrite	PJE
Silver	PR6
Solar Black	P8X

GRADE P3

Atom	P8S
Blossom	P8K
Bullseye	PJF
Ember	P8P
Ion	P8N
Iris	P8J
Krypton	P8F
Ochre	P093
Regatta	P8M
Sienna	P092
Succulent	P8A

GRADE P4

Polished Aluminum	PAL/P
-------------------	-------

LAMINATES

GRADE L1

SOLID COLORS

Black	P
Brownstone	LM13
Bungalow	LM12
Designer White 15051	LDW1
Flint	LM16
Fossil Shale	LEH1
Loft	LM11
Muslin	LM15
Titanium	LT11

ABSTRACT

Ash	LT3B
Handspun Pearl	LAHP
Handspun Dove	LAHD
Handspun Slate	LAHS
Handspun Chestnut	LAHC
Silver Mesh	LT8D

WOODGRAIN

Belair	LWBA
Bourbon Cherry	H
Field Elm	LWFE
Florence Walnut	LFW1
Kingswood Walnut	LK11
Natural Maple	LWD
NeoWalnut	LNU1
Pinnacle	PINC
Shaker Cherry	LW7C

GRADE L2

Beigewood	LWBE
Fawn Cypress	LFC1
Lowell Ash	LLA1
Mangalore Mango	LMM1
Natural Recon	LNR1
Phantom Charcoal	LPC1
Phantom Ecru	LPE1
Portico Teak	LPT1
Skyline Walnut	LSW1
Veranda Teak	LVT1

GRADE L3

Natural Walnut	LWNW
----------------	------

SOLID SURFACE

Designer White	SDW4
Frosty White	SFW3
Night Stars	SNS5
Masoned Concrete	SMC2
Monte Amiata	SMA1

LAMINATE EDGE COLORS

Beigewood	DE
Belair	BA
Black	E4
Bourbon Cherry	H
Brownstone	EY
Bungalow	EX
Designer White	DW
Fawn Cypress	FC
Field Elm	FE
Flint	E9
Florence Walnut	FW
Fossil	EH
Kingswood Walnut	KI
Loft	EV
Lowell Ash	DL
Mangalore Mango	MM
Muslin	EU
Natural Maple	DD
Natural Recon	NR
Natural Walnut	DN
NeoWalnut	NU
Parchment	EN
Phantom Charcoal	PC
Phantom Ecru	PE
Pinnacle	PI
Platinum Metallic	EP
Portico Teak	DP
Shaker Cherry	DF
Skyline Walnut	SW
Titanium	TI
Veranda Teak	VT

**STRATAWOOD
VENEERS**

GRADE V2

CHERRY

Cinnamon/Biltmore Cherry	SC260
Lowell Ash Cherry	SC394
Clear Cherry	SC700
Light Cherry	SC701
Shaker Cherry	SC774
Burnished Cherry	SC777

MAPLE

Field Elm	SE599
Clear Maple	SE800
Harvest Maple	SE856
Beigewood	SE878
Phantom Ecru	SE912
Belair	SE934

OAK

Clear Oak	SF300
Dark Rift Cut Oak	SF331

SILVER OAK

Silver Oak Clear	SB100
Portico Teak Silver Oak	SB150

WALNUT

Florence Walnut	ST579
Light Walnut	ST601
Skyline Walnut	ST625
Pinnacle Walnut	ST679
Sumatra Walnut	ST693

**NATURAL VENEERS —
FLAT CUT**

GRADE V2

CHERRY

Cinnamon/Biltmore Cherry	NC260
Lowell Ash	NC394
Medium Red Cherry	NC512
Light Cherry	NC701
Shaker Cherry	NC774
Burnished Cherry	NC777

MAPLE

Clear Maple	NE800
Harvest Maple	NE856

WALNUT

Ebony Walnut	NT509
Florence Walnut	NT579
Light Walnut	NT601
Skyline Walnut	NT625
Nutmeg Walnut	NT629
Pinnacle Walnut	NT679
Sumatra Walnut	NT693

**NATURAL VENEERS —
RIFT CUT**

GRADE V3

Fawn Cypress Rift Cut Oak	RF108
Light Rift Cut Oak	RF301
Dark Rift Cut Oak	RF331
Phantom Ecru Rift Cut Oak	RF912

Note: Refer to individual product pages for upcharges.

FSC Certified Wood at Allsteel
See page 459 for more information.

The spun aluminum Belong occasional tables offer needed horizontal surfaces for small group meeting areas while providing a pleasing aesthetic.

MODELS AND OPTIONS

The sculptural curved shape and lightweight design are available in two sizes — Coffee (16"H x 32" diameter) or Side (21"H x 16 diameter). The Belong tops are available in laminate, veneer, or glass with painted pan.

APPLICATION

Place in lounge and reception areas, small conference and huddle rooms, media and library areas, and cafés.

KEY FEATURES

Belong offers ample horizontal writing surface as a side table next to a chair or bench, or as a small coffee table surrounded by seating. Its organic hourglass shape provides legroom for users to sit up close when using laptops or tablets.

Belong Side Table

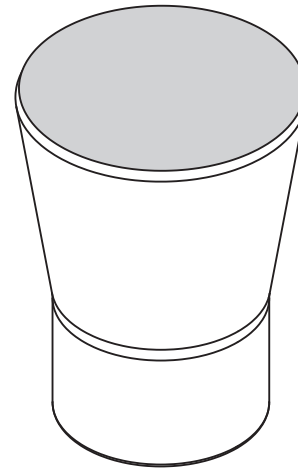

Belong Coffee Table

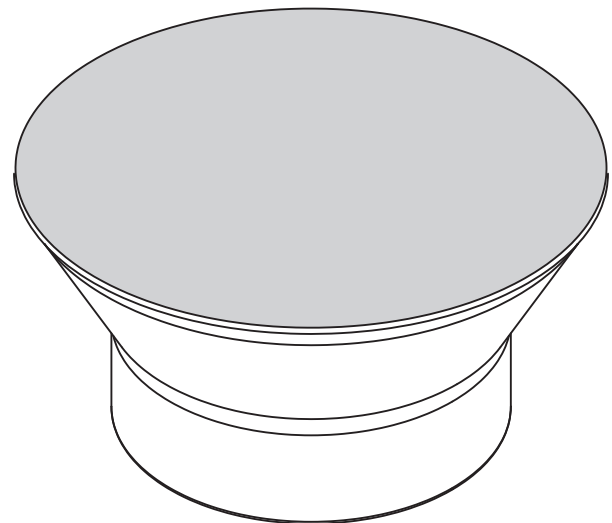

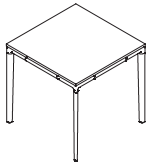

Description	Model Number	Unit Weight	Ship Weight	Cubes	Base			Upcharge List Price – Add to Base Price			
					List Price	L2	L3	V2	V3	Solid B	Solid C
Side Table — 22"W x 22"D x 21½"H											
Laminate Flat Edge	PTSTL	39	49	13.7	\$ 1622	\$ 22	\$ 44				
Veneer Square Edge	PTSTV	37	47	13.7	\$ 2476			\$ 213	\$ 320		
Solid Surface	PTSTS	42	52	13.7	\$ 3244					\$ 66	\$ 131

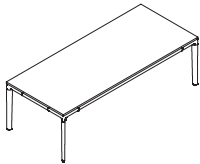

Coffee Table — 52"W x 22"D x 16"H											
Laminate Flat Edge	PTCTL	53	68	16.3	\$ 2081	\$ 33	\$ 66				
Veneer Square Edge	PTCTV	51	66	16.3	\$ 2794			\$ 240	\$ 360		
Solid Surface	PTCTS	77	92	16.3	\$ 4092					\$ 153	\$ 306

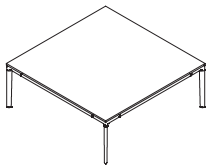

Coffee Table — 42"W x 42"D x 16"H											
Laminate Flat Edge	PTLTL	53	68	24.0	\$ 2187	\$ 39	\$ 77				
Veneer Square Edge	PTLTV	51	66	24.0	\$ 3049			\$ 262	\$ 393		
Solid Surface	PTLTS	111	126	24.0	\$ 4515					\$ 218	\$ 436

PARALLEL

<p>How to specify — Select the Model Number from above.</p> <p>P S . P . L . . S </p>	<p>1st Option: Select the Base Color: See page 326 for selections and Color Codes. P2 Add \$88 Side Table 22" \$109 Coffee Table 52" \$120 Coffee Table 42" P3 Add \$131 Side Table 22" \$164 Coffee Table 52" \$180 Coffee Table 42" P4 Add \$175 Side Table 22" \$218 Coffee Table 52" \$240 Coffee Table 42"</p>	<p>2nd Option: Select the Laminate (if applicable): See page 326 for selections and Color Codes.</p>	<p>2nd Option: Select the Veneer (if applicable): See page 326 for selections and Finish Codes.</p>	<p>2nd Option: Select Solid Surface (if applicable): Grade A SFW3 Frosty White Grade B SDW4 Designer White Grade C SNS5 Night Stars Grade D SMC2 Masoned Concrete SMA1 Monte Amiata More Wilsonart and Corian colors available as specials</p>	<p>3rd Option: Select the Edge Color (Laminate only): See page 326 for selections and Color Codes.</p>	<p>4th Option: Veneer Finish Method (Veneer only): OP Open Pore Low Shin FF Full-Fill Cleartech Add \$218 Side Table \$218 Coffee Tables</p>
---	---	---	--	--	---	---

Examples: PTSTL.P4Q.LDW1.DW PTCTV.PJW.SE800.OP PTLTS.POL.SDW4

Description	Model Number	Base List Price	Upcharge List Price — Add to Base Price		P2 Paint
			L2	L3	
Laminate Tables					
Low Work Table	S911NL	\$ 986	\$ 39	\$ 77	\$ 77
Mid Work Table	S911NM	\$ 1057	\$ 42	\$ 82	\$ 82
High Work Table	S911NH	\$ 1128	\$ 44	\$ 88	\$ 88

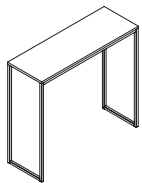
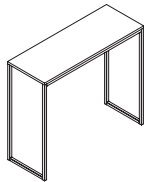
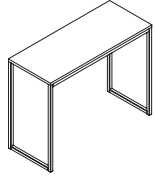

RISE

Table Pricing Example:	Model/Options	Base Price/Upcharges
Step 1: Select Model	S911NL	\$ 986
Step 2: Select Laminate	LDW1 Designer White	\$ 0 upcharge
Step 3: Select Edgeband	DW Designer White	\$ 0 upcharge
Step 4: Select Paint	P8X Solar Black	\$ 77 upcharge
Add Base + applicable Upcharges for Total List Price =		\$ 1063

<p>How to specify — Select the Model Number from above.</p> <p>S 9 1 1 N .</p>	<p>1st Option: FSC Certified Wood (if applicable):</p> <p>FSC Select for FSC Certified Wood</p> <p>F S C .</p>	<p>2nd Option: Select the Laminate</p> <p>See page 326 for options.</p> <p> .</p>	<p>3rd Option: Select the Edge Band</p> <p>See page 326 for options.</p> <p> .</p>	<p>4th Option: Select the Paint</p> <p>See page 326 for options.</p> <p> .</p>
---	---	---	--	--

Example: S911NL.FSC.

Model Number	Overall				
	Ship Weight	Cubes	Height	Width	Depth
S911NL	35	53.3	28"	36"	15"
S911NM	39	72.6	34"	40"	15"
S911NH	43	87.4	38"	42½"	15"



	Description	Model Number	Base List Price	Upcharge List Price — Add to Base Price		P2 Paint
				L2	L3	
	Laminate Tables 20" Round Side Table	ET20	\$ 940	\$ 12	\$ 23	\$ 46
	39" Round Table	ET39	\$ 2114	\$ 32	\$ 62	\$ 91
	14" x 21" Side Table	ET1421	\$ 1331	\$ 18	\$ 34	\$ 62
	21" x 42" Table	ET2142	\$ 1804	\$ 29	\$ 57	\$ 74
	42" x 42" Table	ET4242	\$ 2195	\$ 34	\$ 68	\$ 91

Table Pricing Example:	Model/Options	Base Price/Upcharges
Step 1: Select Model	ET1421	\$ 1331
Step 2: Select Laminate	LWBA Belair	\$ 0 upcharge
Step 3: Select Edgeband	BA Belair	\$ 0 upcharge
Step 4: Select Paint	P8X Solar Black	\$ 62 upcharge
Add Base + applicable Upcharges for Total List Price =		\$ 1393

TWO THIRDS

<p>How to specify — Select the Model Number from above.</p> <p>E T .</p>	<p>1st Option: FSC Certified Wood (if applicable): FSC Select for FSC Certified Wood</p> <p>F S C .</p>	<p>2nd Option: Select the Laminate See page 326 for options.</p> <p> .</p>	<p>3rd Option: Select the Edge Band See page 326 for options.</p> <p> .</p>	<p>4th Option: Select the Paint P8Z Textured Salt P8X Solar Black (add P2 Paint upcharge)</p> <p> .</p>
---	--	--	---	---

Example: ET39.FSC.LWBA.BA.P8X

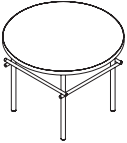
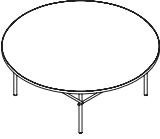
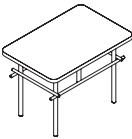
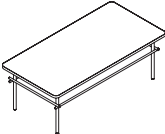
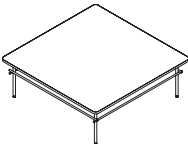
Model Number	Overall				
	Ship Weight	Cubes	Height	Width	Depth
ET20	14	3.4	17.25"	20"	20"
ET39	38	19.4	15"	39"	39"
ET1421	14	3.4	17.25"	21"	14"
ET2142	35	9.1	15"	42"	21"
ET4242	53	18.8	15"	42"	21"

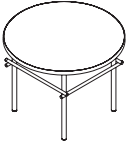
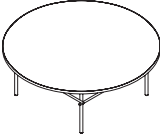
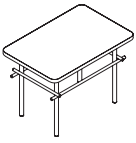
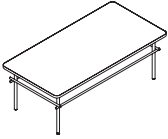
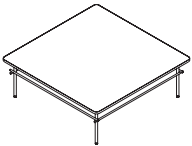
	Description	Model Number	Base List Price	Upcharge List Price — Add to Base Price		P2 Paint
				V2	V3	
	Veneer Tables 20" Round Side Table	EV20	\$ 1455	\$ 146	\$ 291	\$ 46
	39" Round Table	EV39	\$ 2376	\$ 238	\$ 476	\$ 91
	14" x 21" Veneer Side Table	EV1421	\$ 1667	\$ 167	\$ 334	\$ 62
	21" x 42" Veneer Table	EV2142	\$ 2003	\$ 201	\$ 401	\$ 74
	42" x 42" Veneer Table	EV4242	\$ 2463	\$ 247	\$ 493	\$ 91

TWO THIRDS

<p>How to specify — Select the Model Number from above.</p> <p>EV .</p>	<p>1st Option: FSC Certified Wood (if applicable): FSC Select for FSC Certified Wood</p> <p>F S C .</p>	<p>2nd Option: Select the Veneer See page 326 for options.</p> <p> .</p>	<p>3rd Option: Select the Veneer Finish OP Open Pore Low Sheen FF Full Fill Cleartech (add \$225)</p> <p> .</p>	<p>4th Option: Select the Paint P8Z Textured Salt P8X Solar Black (add P2 Paint upcharge)</p> <p> </p>
--	--	--	---	---

Example: EV39.FSC.NC701.FF.P8X

Model Number	Overall				
	Ship Weight	Cubes	Height	Width	Depth
EV20	22	3.4	17.25"	20"	20"
EV39	53	19.4	15"	39"	39"
EV1421	22	3.4	17.25"	21"	14"
EV2142	45	9.1	15"	42"	21"
EV4242	65	18.8	15"	42"	21"



Description	Model Number <i>below</i>	Cubes	Weight					Grade 2 Paint Upcharge
				L1	L2	L3	L7	
Park Lo Side Table								
19½"H x 24"W x 24"D	NARC	10.0	20	\$1058	\$1082	\$1106	\$1201	\$ 30

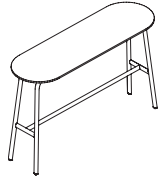

Park Hi Pill Table								
29¾"H x 48"W x 15"D	NA4828RB	14.6	50	\$1208	\$1232	\$1256	\$1351	\$ 45



Park Lo Pill Table								
20½"H x 48"W x 15"D	NA4815RB	11.0	35	\$1082	\$1106	\$1130	\$1225	\$ 36

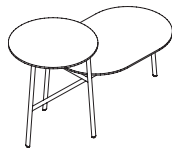

Park Hi Lo Casual Table								
28¾"H x 52¼"W x 24"D	NALC	25.7	52	\$2275	\$2339	\$2400	\$2649	\$ 44

Pricing Example:	Model/Options	Base Price/Upcharges
Step 1: Select Model	NARC	
Step 2: Select Laminate	w/Grade 3 Laminate	\$ 1106
Step 3: Select Paint	Grade 2 Paint	\$ 30 upcharge
Add Base + applicable Upcharges for Total List Price =		\$ 1136

How to specify — Select the Model Number from above.	1st Option: Select FSC (if applicable):	2nd Option: Select the Paint Finish: P1 P2	3rd Option: Select the Laminate Color: See page 326 for selections and color codes.	4th Option: Select the Edge Color: See page 326 for selections and color codes.
N A _ _	_ _ _	_ _ _	_ _ _ _	_ _

Example: NARC.P8X.LWBA.PC

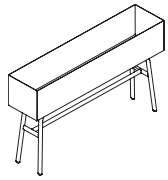

Description	Model	Cubes	Ship Weight	Base List Price	Grade 2 Paint Upcharge
Park Planters — Lo Plant/Storage Pedestal					
28 3/4" H x 48 3/4" W x 11" D	NALP	6.5	53	\$ 1444	\$ 82

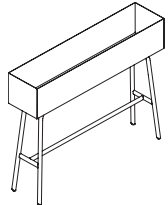

Park Planters — Hi Plant/Storage Pedestal					
38 3/4" H x 48 3/4" W x 11" D	NAHP	10.1	58	\$ 1607	\$ 91

<p>How to specify — Select the Model Number from above.</p> <p>N A .</p>	<p>1st Option: Select the Paint Finish:</p> <p>(P1) (P2)</p> <p> </p>
---	--

Example: NALP.P8X

Description	Model <i>Add options below</i>	Cubes	Ship Weight	List Price with Upcharge		
				L1	L2	L3
Pedestal Planter						
Park Laminate Plant/Storage Pedestal Top	NAPT	1.1	5	\$ 478	\$ 494	\$ 507

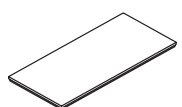

<p>How to specify — Select the Model Number from above.</p> <p>N A P T .</p>	<p>1st Option: Select FSC (if applicable):</p> <p> .</p>	<p>2nd Option: Select the Laminate Color:</p> <p>See page 326 for selections and color codes.</p> <p> .</p>	<p>3rd Option: Select the Edge Color:</p> <p>See page 326 for selections and color codes.</p> <p> </p>
---	--	---	---

Example: NAPT.LWBA.EV

Recharge™ page 341



Rise™ page 342



**RECHARGE
PAINT FINISHES**

TABLE BASES

Textured Designer White	PK7
Textured Flint	P7A
Textured Silver	PR8

**RECHARGE
SCREEN FABRICS**

Dark Grey	DRK
Light Grey	LGT
Medium Grey	MDD

**RECHARGE CONNECTOR
TABLE LAMINATES**

Designer White	LDW1
Flint	LM16

**RECHARGE
TABLE LAMINATES**

GRADE L1

SOLID COLOR

Black	P
Brownstone	LM13
Bungalow	LM12
Designer White	LDW1
Flint	LM16
Fossil Shale	LEH1
Loft	LM11
Muslin	LM15
Titanium	LT11

ABSTRACT

Ash	LT3B
Handspun Pearl	LAHP
Handspun Dove	LAHD
Handspun Slate	LAHS
Handspun Chestnut	LAHC
Silver Mesh	LT8D

WOODGRAIN

Belair	LWBA
Bourbon Cherry	H
Field Elm	LWFE
Florence Walnut	LFW1
Kingswood Walnut	LK11
Natural Maple	LWD
NeoWalnut	LNU1
Pinnacle	PINC
Shaker Cherry	LW7C

GRADE L2

WOODGRAIN

Beigewood	LWBE
Fawn Cypress	LFC1
Lowell Ash	LLA1
Mangalore Mango	LMM1
Natural Recon	LNR1
Phantom Charcoal	LPC1
Phantom Ecu	LPE1
Portico Teak	LPT1
Skyline Walnut	LSW1
Veranda Teak	LVT1

GRADE L3

WOODGRAIN

Natural Walnut	LWNW
----------------------	------

RECHARGE EDGE COLORS

Beigewood	DE
Belair	BA
Black	E4
Bourbon Cherry	H
Brownstone	EY
Bungalow	EX
Designer White	DW
Fawn Cypress	FC
Field Elm	FE
Flint	E9
Florence Walnut	FW
Fossil	EH
Kingswood Walnut	KI
Loft	EV
Lowell Ash	DL
Mangalore Mango	MM
Muslin	EU
Natural Maple	DD
Natural Recon	NR
Natural Walnut	DN
NeoWalnut	NU
Parchment	EN
Phantom Charcoal	PC
Phantom Ecu	PE
Pinnacle	PI
Plyband	PL
Portico Teak	DP
Shaker Cherry	DF
Skyline Walnut	SW
Titanium	TI
Veranda Teak	VT

RISE PAINT FINISHES

GRADE P1

Charblack	CBK
Textured Brownstone	P7J
Textured Designer White	PK7
Textured Flint	P7A
Textured Loft	P7L
Textured Muslin	P7M
Textured Pebble	P8Y
Textured Salt	P8Z
Textured Titanium	P8V

GRADE P2

Night Bronze	P8B
Pyrite	PJE
Silver Texture	PR8
Solar Black	P8X

GRADE P3

Atom	P8S
Blossom	P8K
Bullseye	PJF
Cabernet	P7T
Conifer	P8H
Ember	P8P
Ion	P8N
Iris	P8J
Krypton	P8F
Regatta	P8M
Succulent	P8A

	Description	Model Number Power Location	Ship Weight	Cubes	L1	Laminate L2	L3
Laptop Table 22"L x 17"W x 28"H	No Power	MLM18	37	11.8	\$ 902	\$ 935	\$ 967



<p>How to specify — Select the Model Number from above.</p> <p>MLM .</p>	<p>1st Option: Select the Laminate Color (if applicable): See page 340 for selections and color codes.</p> <p>Connector Tables limited to: LDW1 Designer White LM16 Flint</p> <p> .</p>	<p>2nd Option: Select the Laminate Edge Color (if applicable): See page 340 for selections and color codes. Connector Tables do not require an edge color.</p> <p> .</p>	<p>3rd Option: Select the Table Base Paint Color (if applicable): See page 340 for selections and color codes.</p> <p> .</p>
---	---	--	--

Example: MLM18.LM16.E9.P7A

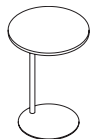

Description	Model Number	Base List Price	Laminate		Paint	
			L2	L3	P2	P3
Rise Accessories						
Laptop Table 28"H x 20"W x 20"D	S911RLTB	\$ 1015	\$ 1054	\$ 1092	\$ 1092	\$ 1130

RISE

<p>How to specify — Select the Model Number from above.</p> <p>S 9 . F S C . L </p>	<p><i>1st Option:</i> FSC Certified Wood (if applicable): FSC Select for FSC Certified Wood</p>	<p><i>2nd Option:</i> Select the Laminate (if applicable): See page 340 for options.</p>	<p><i>3rd Option:</i> Select the Edge Color (if applicable): See page 340 for options.</p>	<p><i>4th Option:</i> Select the Base Paint Color See page 340 for options.</p>
---	---	--	--	---

Example:

Park™ pages 345-346



Townhall™ Peak™ page 347

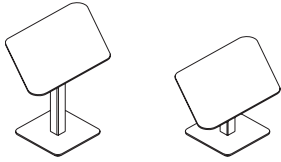

Townhall™ Picnic™ pages 348-349

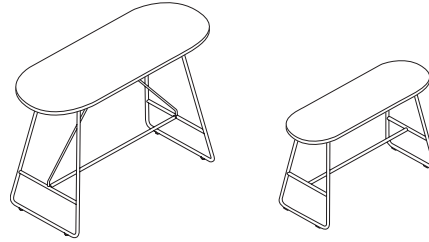

Recharge™ page 350

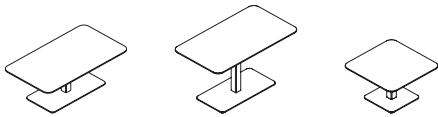

PARK PAINT FINISHES

GRADE P1

Textured Brownstone.....	P7J
Textured Designer White.....	PK7
Textured Flint.....	P7A
Textured Loft.....	P7L
Textured Muslin.....	P7M
Textured Pebble.....	P8Y
Textured Salt.....	P8Z
Textured Titanium.....	P8V

GRADE P2

Textured Silver.....	PR8
Solar Black.....	P8X

GRADE P3

Atom.....	P85
Blossom***.....	P8K
Ember.....	P8P
Ion.....	P8N
Iris.....	P8J
Krypton.....	P8F
Ochre.....	P093
Regatta.....	P8M
Sienna.....	P092
Succulent***.....	P8A

***These colors are intended to be an inspirational option for the trending market. Product application is limited and color availability is approximately two years to coincide with evolving workplace trends.

PARK TABLE LAMINATES

GRADE L1-ABSTRACT

Ash.....	LT3B
Handspun Pearl.....	LAHP
Handspun Dove.....	LAHD
Handspun Slate.....	LAHS
Handspun Chestnut.....	LAHC
Silver Mesh.....	LT8D

GRADE L1-SOLID

Black.....	P
Brownstone.....	LM13
Bungalow.....	LM12
Designer White.....	LDW1
Flint.....	LM16
Fossil Shale.....	LEH1
Loft.....	LM11
Muslin.....	LM15
Titanium.....	LT11

GRADE L1-WOODGRAIN

Belair.....	LWBA
Bourbon Cherry.....	H
Field Elm.....	LWFE
Florence Walnut.....	LWF1
Kingswood Walnut.....	LK11
Natural Maple.....	LWD
NeoWalnut.....	LNU1
Pinnacle.....	PINC
Shaker Cherry.....	LW7C

GRADE L2-WOODGRAIN

Beigewood.....	LWBE
Fawn Cypress.....	LFC1
Lowell Ash.....	LLA1
Mangalore Mango.....	LMM1
Natural Recon.....	LNR1
Phantom Charcoal.....	LPC1
Phantom Ecu.....	LPE1
Portico Teak.....	LPT1
Skyline Walnut.....	LSW1

GRADE L3-WOODGRAIN

Natural Walnut.....	LWNW
---------------------	------

GRADE L4-MARKERBOARD

White Markerboard.....	FMQ1
------------------------	------

GRADE L7-SOLID (TRACELESS)*†

Black Velvet.....	LBV1
Charcoal Velvet.....	LCV1

*Park Storage is available in all grades of laminate except Grade 7.

†LBV1 and LCV1 are warranted for 1 year.

PARK, TOWNHALL & RECHARGE EDGE COLORS

Beigewood.....	DE
Belair.....	BA
Black.....	E4
Bourbon Cherry.....	H
Brownstone.....	EY
Bungalow.....	EX
Designer White.....	DW
Fawn Cypress.....	FC
Field Elm.....	FE
Flint.....	E9
Florence Walnut.....	FW
Fossil.....	EH
Kingswood Walnut.....	KI
Loft.....	EV
Lowell Ash.....	DL
Mangalore Mango.....	MM
Muslin.....	EU
Natural Maple.....	DD
Natural Recon.....	NR
Natural Walnut.....	DN
NeoWalnut.....	NU
Parchment.....	EN
Phantom Charcoal.....	PC
Phantom Ecu.....	PE
Pinnacle.....	PI
Portico Teak.....	DP
Shaker Cherry.....	DF
Skyline Walnut.....	SW
Titanium.....	TI
Veranda Teak.....	VT

SUMMIT/PICNIC PAINT FINISHES

GRADE P1

Black.....	P71
Charblack.....	CBK
Designer White.....	PJW
Flint.....	P02
Textured Designer White.....	PK7
Textured Brownstone.....	P7J
Textured Flint.....	P7A
Textured Loft.....	P7L
Textured Muslin.....	P7M
Textured Pebble.....	P8Y
Textured Salt.....	P8Z
Textured Titanium.....	P8V

GRADE P2

Night Bronze.....	P8B
Solar Black.....	P8X
Pyrite.....	PJE
Silver.....	PR6
Textured Silver.....	PR8

GRADE P3

Atom.....	P8S
Blossom***.....	P8K
Bullseye.....	PJF
Cabernet***.....	P7T
Conifer***.....	P8H
Ember.....	P8P
Ion.....	P8N
Iris.....	P8J
Krypton.....	P8F
Regatta.....	P8M
Succulent***.....	P8A

CLOUD PAINT FINISHES

GRADE P1

Charblack.....	CBK
Textured Designer White.....	PK7
Textured Brownstone.....	P7J
Textured Flint.....	P7A
Textured Loft.....	P7L
Textured Muslin.....	P7M
Textured Pebble.....	P8Y
Textured Salt.....	P8Z
Textured Titanium.....	P8V

GRADE P2

Textured Silver.....	PR8
Solar Black.....	P8X

***These colors are intended to be an inspirational option for the trending market. Product application is limited and color availability is approximately two years to coincide with evolving workplace trends.

TOWNHALL LAMINATES

GRADE L1

ABSTRACT

Ash.....	LT3B
Handspun Pearl.....	LAHP
Handspun Dove.....	LAHD
Handspun Slate.....	LAHS
Handspun Chestnut.....	LAHC
Silver Mesh.....	LT8D

SOLID

Black.....	P
Brownstone.....	LM13
Bungalow.....	LM12
Designer White.....	LDW1
Flint.....	LM16
Fossil Shale.....	LEH1
Loft.....	LM11
Muslin.....	LM15
Titanium.....	LT11

WOODGRAIN

Belair.....	LWBA
Bourbon Cherry.....	H
Field Elm.....	LWFE
Florence Walnut.....	LWF1
Kingswood Walnut.....	LK11
Natural Maple.....	LWD
NeoWalnut.....	LNU1
Pinnacle.....	PINC
Shaker Cherry.....	LW7C

GRADE L2

WOODGRAIN

Beigewood.....	LWBE
Fawn Cypress.....	LFC1
Lowell Ash.....	LLA1
Mangalore Mango.....	LMM1
Natural Recon.....	LNR1
Phantom Charcoal.....	LPC1
Phantom Ecu.....	LPE1
Portico Teak.....	LPT1
Skyline Walnut.....	LSW1

GRADE L3

WOODGRAIN

Natural Walnut.....	LWNW
---------------------	------

RECHARGE PAINT FINISHES

TABLE BASES

Textured Designer White.....	PK7
Textured Flint.....	P7A
Textured Silver.....	PR8

RECHARGE CONNECTOR TABLE LAMINATES

Designer White.....	LDW1
Flint.....	LM16

RECHARGE TABLE LAMINATES

GRADE L1

SOLID COLOR

Black.....	P
Brownstone.....	LM13
Bungalow.....	LM12
Designer White.....	LDW1
Flint.....	LM16
Fossil Shale.....	LEH1
Loft.....	LM11
Muslin.....	LM15
Titanium.....	LT11

ABSTRACT

Ash.....	LT3B
Handspun Pearl.....	LAHP
Handspun Dove.....	LAHD
Handspun Slate.....	LAHS
Handspun Chestnut.....	LAHC
Silver Mesh.....	LT8D

WOODGRAIN

Belair.....	LWBA
Bourbon Cherry.....	H
Field Elm.....	LWFE
Florence Walnut.....	LWF1
Kingswood Walnut.....	LK11
Natural Maple.....	LWD
NeoWalnut.....	LNU1
Pinnacle.....	PINC
Shaker Cherry.....	LW7C

GRADE L2

WOODGRAIN

Beigewood.....	LWBE
Fawn Cypress.....	LFC1
Lowell Ash.....	LLA1
Mangalore Mango.....	LMM1
Natural Recon.....	LNR1
Phantom Charcoal.....	LPC1
Phantom Ecu.....	LPE1
Portico Teak.....	LPT1
Skyline Walnut.....	LSW1

GRADE L3

WOODGRAIN

Natural Walnut.....	LWNW
---------------------	------

Note: Refer to individual product pages for upcharges.

MEETING TABLES OVERVIEW



Description	Model Number <i>Add options below</i>	Cubes	Weight					Grade 2 Paint Upcharge
				L1	L2	L3	L7	
Park Pill Work Table								
28½"H x 57"W x 27"D	NAPWT	18.9	45	\$2186	\$2244	\$2302	\$2531	\$ 56

Pricing Example:	Model/Options	Base Price/Upcharges
Step 1: Select Model	NAPWT	
Step 2: Select Laminate	w/Grade 3 Laminate	\$ 2302
Step 3: Select Paint	Grade 2 Paint	\$ 56 upcharge
Add Base + applicable Upcharges for Total List Price =		\$ 2358

<p>How to specify — Select the Model Number from above.</p> <p>N A </p> <p> .</p>	<p>1st Option: Select FSC (if applicable):</p> <p> .</p>	<p>2nd Option: Select the Paint Finish:</p> <p>P1 P2</p> <p> .</p>	<p>3rd Option: Select the Laminate Color:</p> <p>See page 344 for selections and color codes.</p> <p> .</p>	<p>4th Option: Select the Edge Color:</p> <p>See page 344 for selections and color codes.</p> <p> .</p>
--	--	--	---	---

Example: NAPWT.FSC.P8X.LWBA.BA

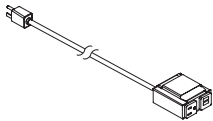
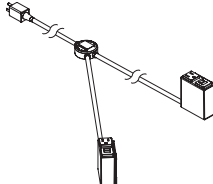
	Description	Model	List Price
	Park Electrical 1 MOD 2 SMPLX <i>* 1 module including 1 A/C, 1 USB-A, and 1 USB-C</i>	NAE1	\$ 428
	2 MOD 4 SMPLX <i>* 2 modules including 1 A/C, 1 USB-A, and 1 USB-C</i>	NAE2	\$ 705
		EASEL ELECTRIC MODULE	NAEESL

PARK

<p>How to specify — Select the Model Number from above.</p>	<p><i>1st Option:</i> Select Braid Color: BC0014 Black Storm BC0046 White/Fog</p>
<p>NAE .</p>	<p> </p>

Example: NAE1.BC0046

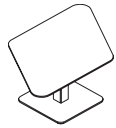

Description	Model <i>Add options below</i>	List Price with Upcharge			
		L1	L2	L3	
Peak Tables					
Peak Table	ACVISTBL	Table	\$ 2079	\$ 2127	\$ 2174
Peak Coffee Table	ACVISCTBL	Coffee Table	\$ 1919	\$ 1967	\$ 2014

Model Number	Overall				
	Ship Weight	Cutbs	Height	Width	Depth
ACVISTBL	50	8.7	27 1/2"	40 1/2"	25 1/2"
ACVISCTBL	45	6.1	17"	40 1/2"	25 1/2"

Peak Tables available in Knife Edge only.
Peak Coffee Table has the same outer dimensions as the Peak Ottoman.

<p>How to specify — Select the Model Number from above.</p>	<p>1st Option: Select FSC (if applicable):</p>	<p>2nd Option: Select the Laminate Color: See page 344 for selections and Color Codes.</p>	<p>3rd Option: Select the Edge Color: See page 344 for selections and Color Codes.</p>	<p>4th Option: Select the Paint Finish: P7A Textured Flint PR8 Textured Silver (Table) (Grade 2 upcharge \$54) PR8 Textured Silver (Coffee Table) (Grade 2 upcharge \$43) PK7 Textured Designer White</p>
<p>ACV I S .</p>	<p> .</p>	<p> .</p>	<p> .</p>	<p> </p>

Example: ACVISTBL.LM15.EU.PK7

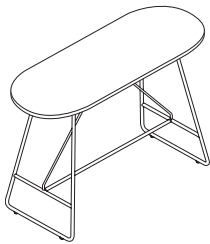

Description	Model <i>Add options below</i>	List Price			Paint Upcharge	
		L1	L2	L3	P2	P3
Picnic Table						
Picnic Table, Bar Height	ACPICT	\$ 2398	\$ 2418	\$ 2435	\$ 133	\$ 331

Picnic Table						
Picnic Table, Bar Height	ACPICT30	\$ 2478	\$ 2501	\$ 2523	\$ 133	\$ 331

TOWNHALL

<p>How to specify — Select the Model Number from above.</p> <p>ACPICT .</p>	<p>1st Option: Select FSC (if applicable):</p> <p> .</p>	<p>2nd Option: Select the Laminate Finish:</p> <p>See page 344 for selections and Color Codes.</p> <p> .</p>	<p>3rd Option: Select the Edge Color:</p> <p>See page 344 for selections and Color Codes.</p> <p> .</p>	<p>4th Option: Select the Paint Finish:</p> <p>See Paint Finishes on page 344.</p> <p>P1 P2 P3</p> <p>P2 add \$133 Table P3 add \$331 Table</p> <p> </p>
--	--	--	---	--

Example: ACPICT.LDW1.DW.P71

Model Number					Overall			Seat			
		Ship Weight	Cables	COM Yardage*	Height	Width	Depth	Height	Width	Depth	Pan Angle (Range)
ACPICT	Table	80	11.3		41"	64"	24"				
ACPICT30	Table	103	9.1		41"	64"	30"				

*COM Yardage is listed for total yardage/feet required for a model, with applicable yardage/feet for individual components listed.



GSA SIN 33721

	Description	Model Number Power Location	Ship Weight	Cubes	Laminate		
					L1	L2	L3
Coffee Table 48"L x 27"W x 17"H	No Power	MLM19	145	24.9	\$ 1821	\$ 1887	\$ 1951

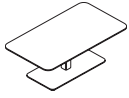

GSA SIN 33721

Work Table 48"L x 27"W x 28"H	No Power	MLM22	150	29.0	\$ 1988	\$ 2054	\$ 2118
-------------------------------	----------	--------------	-----	------	---------	---------	---------

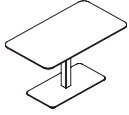

GSA SIN 33721

Corner Table 29"L x 29"W x 17"H	No Power	MLM26	73	14.7	\$ 1744	\$ 1806	\$ 1868
---------------------------------	----------	--------------	----	------	---------	---------	---------

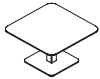

GSA SIN 33721

How to specify —
Select the Model Number from above.

M | L | M | | | | .

1st Option:
Select the Laminate Color (if applicable):
See page 344 for selections and color codes.

Connector Tables limited to:
LDW1 Designer White
LM16 Flint

| | | | | .

Example: MLM22.LWBA.BA.PR8

2nd Option:
Select the Laminate Edge Color (if applicable):
See page 344 for selections and color codes. Connector Tables do not require an edge color.

| | .

3rd Option:
Select the Table Base Paint Color (if applicable):
See page 344 for selections and color codes.

| | | | | .

Park™ page [353-354](#)

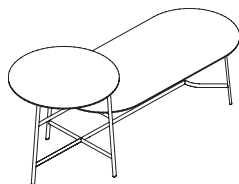

PARK PAINT FINISHES

GRADE P1

Textured Brownstone.....	P7J
Textured Designer White.....	PK7
Textured Flint.....	P7A
Textured Loft.....	P7L
Textured Muslin.....	P7M
Textured Pebble.....	P8Y
Textured Salt.....	P8Z
Textured Titanium.....	P8V

GRADE P2

Textured Silver.....	PR8
Solar Black.....	P8X

GRADE P3

Atom.....	P85
Blossom***.....	P8K
Ember.....	P8P
Ion.....	P8N
Iris.....	P8J
Krypton.....	P8F
Ochre.....	P093
Regatta.....	P8M
Sienna.....	P092
Succulent***.....	P8A

***These colors are intended to be an inspirational option for the trending market. Product application is limited and color availability is approximately two years to coincide with evolving workplace trends.

PARK TABLES LAMINATES

GRADE L1-ABSTRACT

Ash.....	LT3B
Handspun Pearl.....	LAHP
Handspun Dove.....	LAHD
Handspun Slate.....	LAHS
Handspun Chestnut.....	LAHC
Silver Mesh.....	LT8D

GRADE L1-SOLID

Black.....	P
Brownstone.....	LM13
Bungalow.....	LM12
Designer White.....	LDW1
Flint.....	LM16
Fossil Shale.....	LEH1
Loft.....	LM11
Muslin.....	LM15
Titanium.....	LTI1

GRADE L1-WOODGRAIN

Belair.....	LWBA
Bourbon Cherry.....	H
Field Elm.....	LWFE
Florence Walnut.....	LFW1
Kingswood Walnut.....	LK11
Natural Maple.....	LWD
NeoWalnut.....	LNU1
Pinnacle.....	PINC
Shaker Cherry.....	LW7C

GRADE L2-WOODGRAIN

Beigewood.....	LWBE
Fawn Cypress.....	LFC1
Lowell Ash.....	LLA1
Mangalore Mango.....	LMM1
Natural Recon.....	LNR1
Phantom Charcoal.....	LPC1
Phantom Ecu.....	LPE1
Portico Teak.....	LPT1
Skyline Walnut.....	LSW1

PARK TABLES LAMINATES — CONTINUED

GRADE L3-WOODGRAIN

Natural Walnut.....	LWNW
---------------------	------

GRADE L4-MARKERBOARD

White Markerboard.....	FMQ1
------------------------	------

GRADE L7-SOLID (TRACELESS)*†

Black Velvet.....	LBV1
Charcoal Velvet.....	LCV1

*Park Storage is available in all grades of laminate except Grades 4 and 7.

†LBV1 and LCV1 are warranted for 1 year.

PARK EDGE COLORS

Beigewood.....	DE
Belair.....	BA
Black.....	E4
Bourbon Cherry.....	H
Brownstone.....	EY
Bungalow.....	EX
Designer White.....	DW
Fawn Cypress.....	FC
Field Elm.....	FE
Flint.....	E9
Florence Walnut.....	FW
Fossil.....	EH
Kingswood Walnut.....	KI
Loft.....	EV
Lowell Ash.....	DL
Mangalore Mango.....	MM
Muslin.....	EU
Natural Maple.....	DD
Natural Recon.....	NR
Natural Walnut.....	DN
NeoWalnut.....	NU
Parchment.....	EN
Phantom Charcoal.....	PC
Phantom Ecu.....	PE
Pinnacle.....	PI
Plyband.....	PL
Portico Teak.....	DP
Shaker Cherry.....	DF
Skyline Walnut.....	SW
Titanium.....	TI
Veranda Teak.....	VT

NOTE: \$33 upcharge on Woodgrain T-Mold.

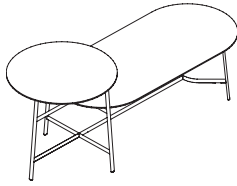

Description	Model Number <i>Add options below</i>	Cubes	Weight					Grade 2 Paint Upcharge
				L1	L2	L3	L7	
Park Hi Lo Meeting Table 41"H x 107¼"W x 42"D	NALCF	34.8	146	\$6562	\$6689	\$6812	\$7307	\$ 259





Pricing Example:	Model/Options	Base Price/Upcharges
Step 1: Select Model	NALCF	
Step 2: Select Laminate	w/Grade 3 Laminate	\$ 6812
Step 3: Select Paint	Grade 2 Paint	\$ 259 upcharge
Add Base + applicable Upcharges for Total List Price =		\$ 7071

How to specify — Select the Model Number from above.	1st Option: Select FSC (if applicable):	2nd Option: Select the Paint Finish: P1 P2	3rd Option: Select the Laminate Color: See page 352 for selections and color codes.	4th Option: Select the Edge Color: See page 352 for selections and color codes.	5th Option: Select whether Grommet (Park Hi Lo Meeting Table only): N No grommet G Grommet (\$13 upcharge)	6th Option: Select the Grommet Color (Park Hi Lo Meeting Table only): E4 Black E9 Flint DW Designer White EV Loft EU Muslin TI Titanium
N A L C F

Example: NALCF.FSC.LWBA.BA.G.E9

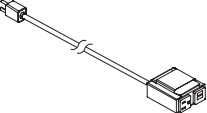
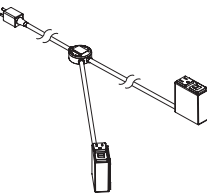
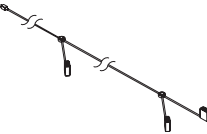
PARK

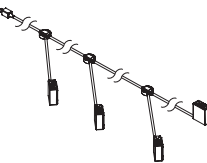
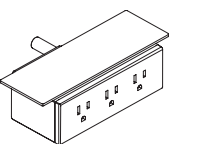
	Description	Model	List Price
	<p>Park Electrical 1 MOD 2 SMPLX * 1 module including 1 A/C, 1 USB-A, and 1 USB-C</p>	<p>NAE1</p>	<p>\$ 428</p>
	<p>2 MOD 4 SMPLX * 2 modules including 1 A/C, 1 USB-A, and 1 USB-C</p>	<p>NAE2</p>	<p>\$ 705</p>
	<p>3 MOD 5 SMPLX 1 USB * 3 modules including 1 A/C, 1 USB-A, and 1 USB-C</p>	<p>NAE3-1USB</p>	<p>\$ 941</p>
	<p>3 MOD 3 SMPLX 3 USB * 3 modules including 1 A/C, 1 USB-A, and 1 USB-C</p>	<p>NAE3-3USB</p>	<p>\$ 1254</p>
	<p>4 MOD 8 SMPLX * 4 modules including 1 A/C, 1 USB-A, and 1 USB-C</p>	<p>NAE4</p>	<p>\$ 1411</p>
	<p>EASEL ELECTRIC MODULE</p>	<p>NAEESL</p>	<p>\$ 471</p>

<p><i>How to specify —</i> Select the Model Number from above.</p> <p>NAE .</p>	<p><i>1st Option:</i> Select Braid Color: BC0014 Black Storm BC0046 White/Fog</p> <p> </p>
---	---

Example: NAE3.BC0046

Admix™ is an innovative table system designed to be easily adaptable and flexible to meet the needs of collaborative teams and hybrid settings. Inspired by light-scale tables, this user-friendly table system provides the functionality and application range of a training table that is effortlessly reconfigurable. With teamwork being at the forefront of today's office environment, Admix™ offers ancillary components with thoughtfully executed technology support for collaborative work in the office and equitable hybrid meetings.

APPLICATION

Full collection that offers countless configuration options to support the various types of collaborative meetings.

- Collaborative Spaces
 - Conference
 - Project rooms
 - Makers space
 - Open Collaborative
- Learning Spaces
 - Reconfigurable tables
 - Training rooms
- Digital Meetings
 - Equitable for in person and view from camera
 - Proper viewing angles and viewing distance

SPECIFICATION CHOICE

Range of shapes, sizes, and configurations to meet the needs of any space available in an array of materials.

1. Choose your top
 - Shapes, sizes
2. Choose your base
 - 4 heights available: continental, standard, counter, bar
 - Footrests
 - Shelving options
 - Caster/glide/wheelbarrow
3. Choose your style
 - Veneer, laminate, metal finishes
4. Choose your technology
 - Power integrated into tables
 - Mobile powered satellite tables
 - Wire management under surface and vertically down leg
 - Braided cord wrapped around wire hook

KEY FEATURES

Feature rich product that supports user choice to adapt to the needs of highly collaborative teams and video conference settings.

- Interchangeable caster/glide
- Telescoping base
- In surface and under mount power
- Braided cord power units
- Footrest standard on counter and bar height
- Media tops and media walls
- Homebase accessories - bag hook, desk mat, tray
- PET wire manager
- Tables with shelving
- Organic top shapes

OPTIONS

All tops are available in veneer or laminate with a flat or knife edge.

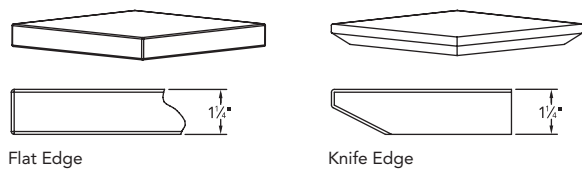

Tables can be specified with 4 casters, 4 glides, or a wheelbarrow setup (2 casters, 2 glides). Casters are available in silver or black. The caster and glide are integrated into a casting at bottom of leg to provide interchangeability over the life of the product.

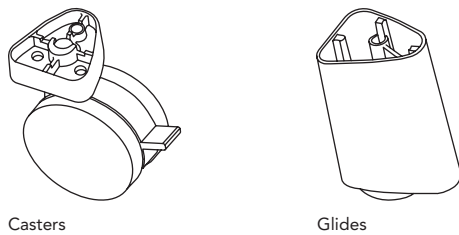

LAMINATE TOPS

SINGLE-PIECE TOPS – Woodgrain laminates as standard product are always oriented with the grain direction running parallel to the length of the table top.

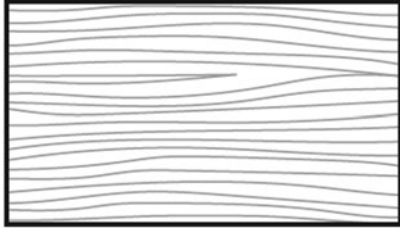

TWO & THREE PIECE TOPS – Tops longer than 96". Woodgrain laminates as standard product are always oriented with the grain direction running parallel to the length of the tabletop. Please note that 2-piece tops, in woodgrain colors, will not have exact grain alignment in the center where the two halves meet, a reasonable match can be expected. Allsteel cannot guarantee a grain match on tables that are 60"W. Woodgrain laminates will be aligned within 3/8" across seams unless otherwise noted in the price guide pages.

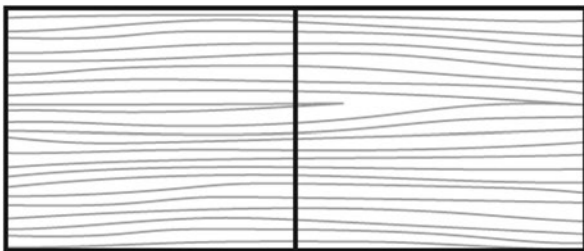

SPECIAL TOPS – Specials for wide tables. Woodgrain laminates as specials wider than 60" are always oriented with the grain direction running parallel to the seam of the tabletop. Allsteel will create best match grain alignment but cannot guarantee a perfect match along the seam between the pieces of laminate on two and three piece tops.

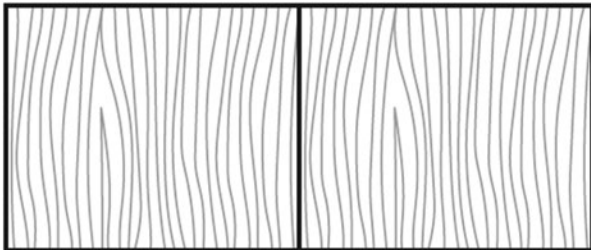

VENEER TOPS

SINGLE-PIECE TOPS – All veneer single piece tops are oriented with the grain direction running parallel to the length of the table top.

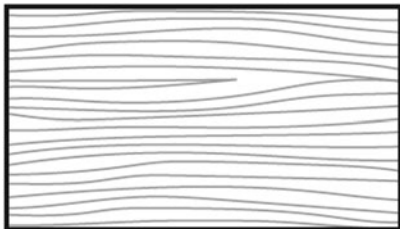

MULTI-PIECE TOPS – All veneer multi-piece tops are oriented with the grain direction running parallel to the seam of the table top.

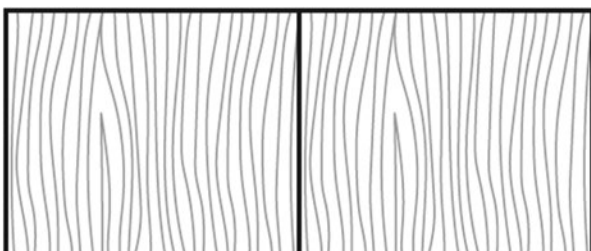

ADMIX

PAINT FINISHES

GRADE P1	
Black.....	P71
Brownstone.....	P7D
Bungalow.....	P7C
Charblack.....	CBK
Cinder.....	P7Q
Cove.....	P096
Designer White.....	PJW
Designer White Texture.....	PK7
Dune.....	P094
Flint.....	P02
Fossil.....	P28
Harbor.....	P097
Loft.....	P7B
Muslin.....	P4J
Pebble.....	P8R
Pewter.....	P8D
Sage.....	P095
Salt.....	P8C
Textured Brownstone.....	P7J
Textured Flint.....	P7A
Textured Loft.....	P7L
Textured Muslin.....	P7M
Textured Pebble.....	P8Y
Textured Salt.....	P8Z
Textured Titanium.....	P8V
Titanium.....	P8T
GRADE P2	
Champagne Metallic.....	PR5
Designer White 65 High Gloss.....	P8W
Gunmetal Metallic.....	PR3
Night Bronze.....	P8B
Platinum Metallic.....	PR2
Pyrite.....	PJE
Silver.....	PR6
Silver Texture.....	PR8
Solar Black.....	P8X
GRADE P3	
Atom.....	P8S
Blossom***.....	P8K
Bullseye.....	PJF
Ember.....	P8P
Ion.....	P8N
Iris.....	P8J
Krypton.....	P8F
Regatta.....	P8M
Succulent***.....	P8A

***These colors are intended to be an inspirational option for the trending market. Product application is limited and color availability is approximately two years to coincide with evolving workplace trends.

LAMINATES

GRADE L1	
SOLID	
Black.....	P
Brownstone.....	LM13
Bungalow.....	LM12
Designer White.....	LDW1
Flint.....	LM16
Fossil Shale.....	LEH1
Loft.....	LM11
Muslin.....	LM15
Titanium.....	LTI1
ABSTRACT	
Ash.....	LT3B
Handspun Pearl.....	LAHP
Handspun Dove.....	LAHD
Handspun Slate.....	LAHS
Handspun Chestnut.....	LAHC
Silver Mesh.....	LT8D
WOODGRAIN	
Belair.....	LWBA
Bourbon Cherry.....	H
Field Elm.....	LWFE
Florence Walnut.....	LWF1
Kingswood Walnut.....	LK11
Natural Maple.....	LWD
Neo Walnut.....	LNU1
Pinnacle.....	PINC
Shaker Cherry.....	LW7C
GRADE L2	
WOODGRAIN	
Beigewood.....	LWBE
Fawn Cypress.....	LFC1
Lowell Ash.....	LLA1
Mangalore Mango.....	LMM1
Natural Recon.....	LNR1
Phantom Charcoal.....	LPC1
Phantom Ecu.....	LPE1
Portico Teak.....	LPT1
Skyline Walnut.....	LSW1
Veranda Teak.....	LVT1
GRADE L3	
Natural Walnut.....	LWNW

LAMINATE EDGE COLORS

Beigewood.....	DE
Belair.....	BA
Black.....	E4
Bourbon Cherry.....	H
Brownstone.....	EY
Bungalow.....	EX
Designer White.....	DW
Fawn Cypress.....	FC
Field Elm.....	FE
Flint.....	E9
Florence Walnut.....	FW
Fossil.....	EH
Kingswood Walnut.....	KI
Loft.....	EV
Lowell Ash.....	DL
Mangalore Mango.....	MM
Muslin.....	EU
Natural Maple.....	DD
Natural Recon.....	NR
Natural Walnut.....	DN
Neo Walnut.....	NU
Parchment.....	EN
Phantom Charcoal.....	PC
Phantom Ecu.....	PE
Pinnacle.....	PI
Platinum Metallic.....	EP
Plyband.....	PL
Portico Teak.....	DP
Shaker Cherry.....	DF
Skyline Walnut.....	SW
Titanium.....	TI
Veranda Teak.....	VT

LAMINATE BASE FINISHES

L1 – SOLID	
Black.....	P
Designer White.....	LDW1
Flint.....	LM16
Loft.....	LM11
L1 – WOODGRAIN	
Bourbon Cherry.....	H
Field Elm.....	LWFE
Florence Walnut.....	LWF1
Kingswood Walnut.....	LK11
Natural Maple.....	LWD
Neo Walnut.....	LNU1
Pinnacle.....	PINC
Shaker Cherry.....	LW7C
L2 – WOODGRAIN	
Beigewood.....	LWBE
Fawn Cypress.....	LFC1
Lowell Ash.....	LLA1
Mangalore Mango.....	LMM1
Natural Recon.....	LNR1
Phantom Charcoal.....	LPC1
Phantom Ecu.....	LPE1
Skyline Walnut.....	LSW1
Veranda Teak.....	LVT1
L3 – WOODGRAIN	
Natural Walnut.....	LWNW

STRATAWOOD VENEERS

GRADE V2	
CHERRY	
Stratawood Cinnamon Cherry.....	SC260
Stratawood Lowell Ash.....	SC394
Stratawood Clear Cherry.....	SC700
Stratawood Light Cherry.....	SC701
Stratawood Shaker Cherry.....	SC774
Stratawood Burnished Cherry.....	SC777
MAPLE	
Field Elm*.....	SE599
Clear Maple.....	SE800
Harvest Maple.....	SE856
Beigewood*.....	SE878
Phantom Ecu*.....	SE912
Belair*.....	SE934
OAK	
Clear Silver Oak.....	SB100
Portico Teak Silver Oak.....	SB150
RIFT OAK	
Clear Oak.....	SF300
Dark Rift Cut Oak.....	SF331
WALNUT	
Florence Walnut.....	ST579
Light Walnut.....	ST601
Skyline Walnut.....	ST625
Pinnacle Walnut.....	ST679
Sumatra Walnut.....	ST693
WASHED WALNUT	
Clear.....	SW600
Smoked Gray*.....	SW612
Smoked Onyx*.....	SW697

*Use OP Top Fin Only.

NATURAL VENEERS — FLAT CUT

GRADE V2	
CHERRY	
Cinnamon/Biltmore Cherry.....	NC260
Lowell Ash.....	NC394
Medium Red Cherry.....	NC512
Light Cherry.....	NC701
Shaker Cherry.....	NC774
Burnished Cherry.....	NC777
MAPLE	
Natural Maple-Clear.....	NE800
Harvest Maple.....	NE856
WALNUT	
Ebony Walnut*.....	NT509
Florence Walnut.....	NT579
Light Walnut.....	NT601
Skyline Walnut.....	NT625
Nutmeg Walnut.....	NT629
Pinnacle Walnut.....	NT679
Sumatra Walnut.....	NT693

*Use OP Top Fin Only.

NATURAL VENEERS — RIFT CUT & QUARTER CUT

GRADE V3	
WHITE OAK	
Fawn Cypress Rift Cut Oak*.....	RF108
Light Rift Cut Oak.....	RF301
Dark Rift Cut Oak.....	RF331
Phantom Ecu Rift Cut Oak*.....	RF912
*Use OP Top Fin Only.	
QUARTER CUT WALNUT	
Ebony*.....	QT509
Florence.....	QT579
Light.....	QT601
Skyline.....	QT625
Nutmeg.....	QT629
Pinnacle.....	QT679
Sumatra.....	QT693

*Use OP Top Fin Only.

All of Allsteel's tables are level® – 2 certified to the ANSI/BIFMA e3 Furniture Sustainability Standard. See www.levelcertified.org for more information.

NOTE: Refer to individual product pages for upcharges.

FABRICS

GRADE A

NOBLE

Onyx.....	NB-006
Thunder.....	NB-016
Charcoal.....	NB-046
Greige.....	NB-026
Dove.....	NB-036
Beach.....	NB-037
Java.....	NB-000
Slate Grey.....	NB-066
Stone.....	NB-067
Rattan.....	NB-057
Tundra.....	NB-076
Folkstone.....	NB-056
Sangria.....	NB-008
White.....	NB-047
Blue Fog.....	NB-024
Apricot.....	NB-009
Teal.....	NB-014
Buff.....	NB-007
Spice.....	NB-019
Mocha.....	NB-010
Paprika.....	NB-001
Camel.....	NB-017
Cream.....	NB-027
Basil.....	NB-003
Indigo.....	NB-004
Citrus.....	NB-013
Dijon.....	NB-002

ADMIX

All of Allsteel's tables are level® – 2 certified to the ANSI/BIFMA e3 Furniture Sustainability Standard. See www.levelcertified.org for more information.

NOTE: Refer to individual product pages for upcharges.

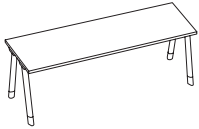

Telescoping Reconfigurable Tables

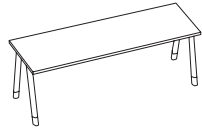

Fixed Reconfigurable Tables — Outset Legs Shown

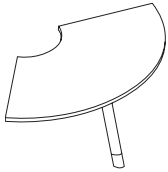

Corner Connector Tops

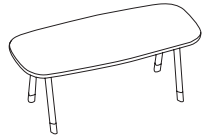

Personal Tables

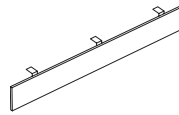

Modesty Panels

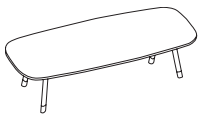

Meeting Tables — Continental Height

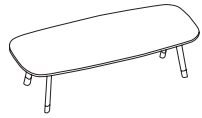

Standard Height

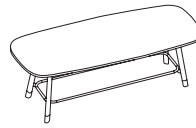

Counter Height

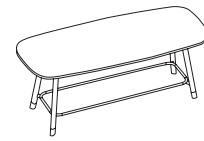

Bar Height

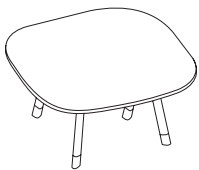

Small Meeting Tables — Continental Height

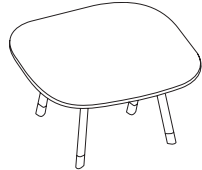

Standard Height



Counter Height



Bar Height



Small Meeting Tables w/ Shelf — Counter Height



Bar Height



V Shape Media Tables — Standard Height

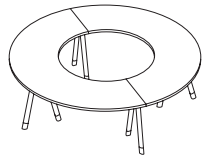

Full Rounds Open Center — Standard Height

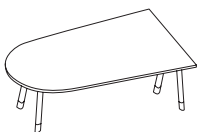

Freestanding Media Tables — Continental Height

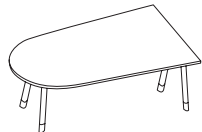

Standard Height



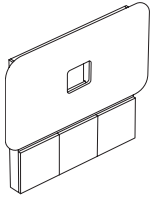

Wall Mounted Media Tables — Continental Height

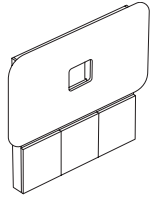

Standard Height

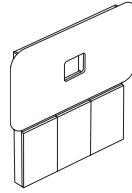

Counter Height

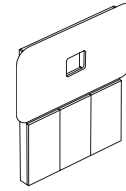

Bar Height

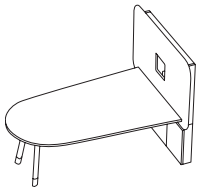

Media Wall Tables — Continental Height

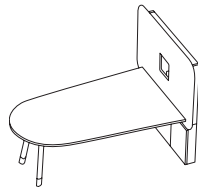

Standard Height

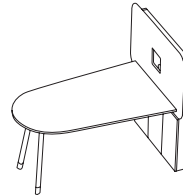

Bar Height

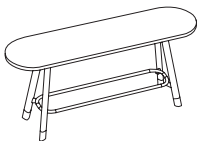

Perch Tables — Counter Height



Bar Height

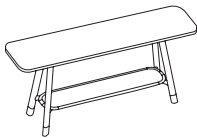

Console Tables w/ Low Shelf — Counter Height



Bar Height



Project Cart w/ 2 Shelves — Counter Height



Bar Height



Satellite Table — Counter Height

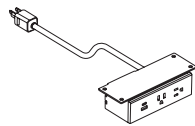

Under Worksurface Power Module

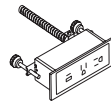

In Surface Bezel Mount Power

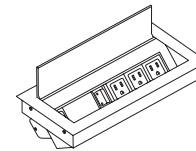

In Surface Tech Module

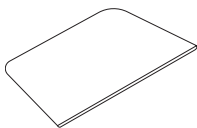

Accessory Deskpad

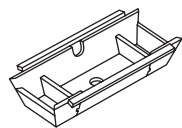

Accessory PET Undersurface Wire Manager

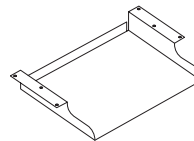

Accessory Tray



Accessory Dual-Purpose Bag Hook / Wire Hook

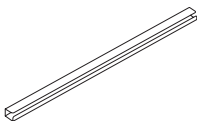

Accessory Vertical Wire Manager

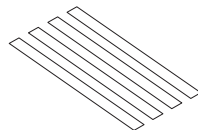

Accessory Vertical Wire Manager Strap

UNDER MOUNT POWER & IN SURFACE BEZEL MOUNT POWER

Power unit available in an under mount or in surface bezel mount installation. In surface requires cutout to be specified in worksurface. Cut out size is 1.938" x 6.313".

Units come standard with 2 power simplexes and a combo USB-A + USB-C. 1 power simplex is rotated 90 degrees to accommodate various plug styles.

Standard plug is 10ft cord length, Hardwire conduit is 6ft, and Braided cord is 10ft length. Interlink IQ option also available for daisy chain applications.

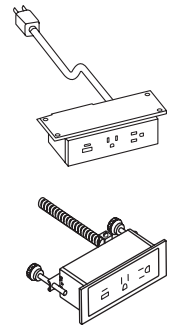

IN SURFACE TECH MODULE

Power unit requires cutout to be specified in worksurface. Units available with Extron plates or data plates to accommodate various Audio/Video requirements. Cut out size is 5.025" x 11.094".

Corded

Corded models plug directly into an outlet and cannot plug into other corded power modules. In order to plug into other units the units need to be hard-wired.

Hardwire

Hardwire models are provided with 10 feet of sealtight cable. Customers must furnish junction boxes, conduit, and additional wire to be in compliance with local and national codes.

Qi charging is available on Corded and Hardwire versions.

- Includes 3 Qi charging coils (5 watts each) for wireless charging.
- Units have LED indicator lights below the lid's surface.
- Units house power and charging USB inside. All units are Qi certified.

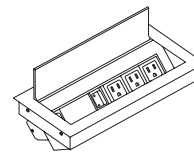
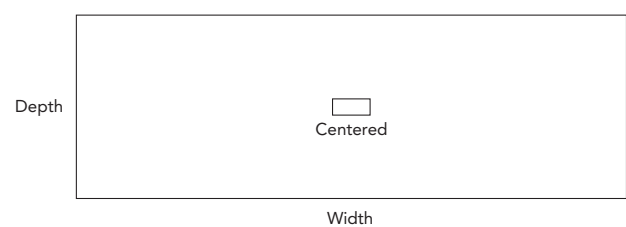
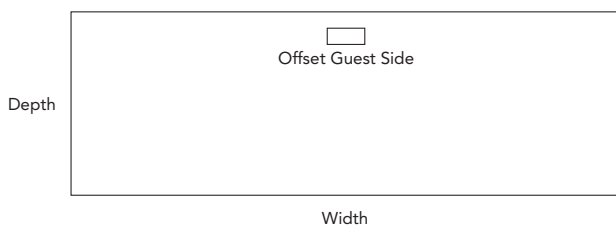

Table Type	C1 Cutout Option		C2 Cutout Option	
	Depth Location	Width Location	Depth Location	Width Location
24"D Reconfigurable Tables	5" to edge of cutout	Centered	n/a	n/a
30"D Reconfigurable Tables	8" to edge of cutout	Centered	n/a	n/a
24" Personal Tables	5" to edge of cutout	Centered	n/a	n/a
30" Personal Tables	8" to edge of cutout	Centered	n/a	n/a
Meeting Tables	Centered	Centered	Centered	Equally Spaced
Small Meeting Tables	Centered	Centered	n/a	n/a
30"D V Media (3 cutouts total)	8" to edge of cutout	Qty 1 Centered on Each Length, Qty 1 Centered on Corner Connector	n/a	n/a
24"D Full Round (4 cutouts total)	5" to edge of cutout	4 Equally Spaced	n/a	n/a
Media Tops	Centered	Centered	n/a	n/a
Perch Tables	Centered	Centered	n/a	n/a
Console Tables	Centered	Centered	n/a	n/a
Project Cart	Centered	Centered	n/a	n/a



PET UNDERSURFACE WIRE MANAGER

Made from 100% PET and provides a warmer, softer feel for a wire manager solution. 12mm thickness in dark grey color. Ends open for easy wire management and to allow the wire manager to sit directly under an external stiffener bar.

Attaches to bottom of worksurface with screws through flanges. Access door opens for easy access to inside of unit. Interior height approx 4" and trapezoid shape allows for interior width from 4" at bottom to 6" at top of unit. Interior dimensions also allow for it to mount under an insurface bezel mount power unit.

Available in 18", 36", and 48" widths. Multiple units may be used in combination on larger tables — recommend 3-12" between units when placed end to end. Unit is optional and must be ordered separately.

Designed for the Environment

- Low VOC
- HPD
- Cal 01350 Emissions Compliant
- Rapidly renewable content
- Prop 65 Compliant
- Declare Compliant
- Red List Compliant
- No FR Additives
- No Conflict Minerals

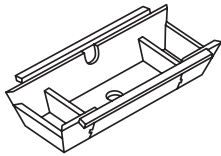
**DUAL PURPOSE WIRE HOOK / BAG HOOK**

The dual purpose wire hook / bag hook is ideal for reconfigurable environments with mobile tables. Intended to be used with a braided cord where the cord can be easily wrapped up. Max load capacity is 20lbs. Unit is optional and must be ordered separately.

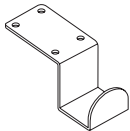

METAL VERTICAL WIRE MANAGER

The vertical wire manager is bent sheet metal and attaches to inside of leg with double stick tape. Unit is powder coated in all Admix™ metal colors to allow it to match the chosen leg color. Interior dimensions are approximately 1" x 1" with 1 side partially open for wires to be easily routed to inside of unit.

Unit is optional and must be ordered separately.

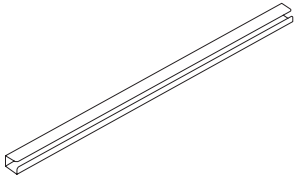
**VELCRO STRAP VERTICAL WIRE MANAGER**

Model ships with quantity 4 velcro straps. Ideal for light duty braided cord applications or standard plug units where cord is visible. Not recommended for hardwire conduit. Made from 11" long x 0.75" wide two-side hook and loop velcro. Unit is optional and must be ordered separately.

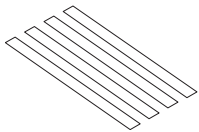

- Top and Base ordered separately. Telescoping tops intended to be used with telescoping bases.
- Option for cutout only, order power units separately.
- Reference page 361 for cutout locations.
- Available in veneer or laminate tops, flat edge only.
- Edgeband color option specified separately for laminate.
- Tops ship with pilot holes for locating base.
- Telescoping inset range per side: 60"W = 8.75", 66"W = 10.0", 72"W = 11.0", 78"W = 12.0", 84"W = 12.0"
- Base includes external stiffeners for tops, telescoping rail system and threaded knob to lock down by hand.
- Base ships knocked down.
- Telescoping tables not for use with accessory tray ATLADM-ACCTRAY due to rail system.

Description	Model Number add "L" for Laminate or "V" for Veneer	Ship Weight	Cubes	Laminate List Price			Veneer List Price	
				L1	L2	L3	V2	V3
Rectangle Telescoping Tops Flat Edge								
24"D x 60"W	ATLADM-TTREC □ 2460F	4	4.1	\$ 527	\$ 554	\$ 582	\$ 1389	\$ 1515
24"D x 66"W	ATLADM-TTREC □ 2466F	49	4.5	\$ 549	\$ 577	\$ 606	\$ 1474	\$ 1608
24"D x 72"W	ATLADM-TTREC □ 2472F	53	4.9	\$ 571	\$ 601	\$ 630	\$ 1649	\$ 1799
24"D x 78"W	ATLADM-TTREC □ 2478F	58	5.3	\$ 621	\$ 653	\$ 685	\$ 1714	\$ 1870
24"D x 84"W	ATLADM-TTREC □ 2484F	62	5.7	\$ 670	\$ 706	\$ 740	\$ 1782	\$ 1944
30"D x 60"W	ATLADM-TTREC □ 3060F	56	5.0	\$ 615	\$ 647	\$ 679	\$ 1528	\$ 1667
30"D x 66"W	ATLADM-TTREC □ 3066F	61	5.5	\$ 643	\$ 676	\$ 709	\$ 1600	\$ 1745
30"D x 72"W	ATLADM-TTREC □ 3072F	67	6.0	\$ 671	\$ 707	\$ 741	\$ 1683	\$ 1836
30"D x 78"W	ATLADM-TTREC □ 3078F	72	6.5	\$ 740	\$ 779	\$ 817	\$ 1802	\$ 1966
30"D x 84"W	ATLADM-TTREC □ 3084F	78	7.0	\$ 808	\$ 850	\$ 892	\$ 1930	\$ 2105

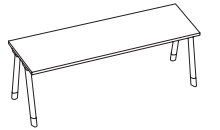
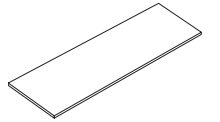

Example of Built-up Table

Description	Model Number add "L" for Laminate or "V" for Veneer	Ship Weight	Cubes	Laminate List Price			Veneer List Price	
				L1	L2	L3	V2	V3
Rounded Rectangle Telescoping Tops Flat Edge								
24"D x 60"W	ATLADM-TTRREC □ 2460F	45	4.1	\$ 580	\$ 610	\$ 640	\$ 1527	\$ 1666
24"D x 66"W	ATLADM-TTRREC □ 2466F	49	4.5	\$ 604	\$ 635	\$ 666	\$ 1622	\$ 1769
24"D x 72"W	ATLADM-TTRREC □ 2472F	53	4.9	\$ 628	\$ 660	\$ 693	\$ 1814	\$ 1979
24"D x 78"W	ATLADM-TTRREC □ 2478F	58	5.3	\$ 683	\$ 719	\$ 754	\$ 1886	\$ 2057
24"D x 84"W	ATLADM-TTRREC □ 2484F	62	5.7	\$ 737	\$ 776	\$ 814	\$ 1961	\$ 2139
30"D x 60"W	ATLADM-TTRREC □ 3060F	56	5.0	\$ 677	\$ 713	\$ 748	\$ 1681	\$ 1834
30"D x 66"W	ATLADM-TTRREC □ 3066F	61	5.5	\$ 707	\$ 744	\$ 781	\$ 1760	\$ 1920
30"D x 72"W	ATLADM-TTRREC □ 3072F	67	6.0	\$ 738	\$ 777	\$ 815	\$ 1852	\$ 2020
30"D x 78"W	ATLADM-TTRREC □ 3078F	72	6.5	\$ 814	\$ 857	\$ 898	\$ 1982	\$ 2162
30"D x 84"W	ATLADM-TTRREC □ 3084F	78	7.0	\$ 889	\$ 935	\$ 981	\$ 2122	\$ 2315

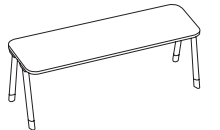
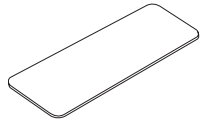

Example of Built-up Table

How to specify — Select the Model Number from above. ATLADM - TTR	1st Option: FSC Certified Wood: X Standard - No FSC F FSC Certified	2nd Option: Laminate/Veneer: See page 357 for finishes.	3rd Option: Edge (Laminate): See page 357 for finishes.	3rd Option: Top Finish (Veneer): FF Full Fill +\$282 OP Open Pore Low Sheen	4th Option: Cutout: GN No Grommet C1E 1 Bezel Mount Power

Example: ATLADM-TTREC□2460F.X.LDW1.DW.GN

Description	Model	Ship Weight	Cubes	List Price	
				P1	P2
Telescoping Bases — Standard Height					
For 60"W Tops	ATLADM-BRTLM60S	61	4.0	\$ 3052	\$ 3345
For 66"W Tops	ATLADM-BRTLM66S	62	4.1	\$ 3088	\$ 3381
For 72"W Tops	ATLADM-BRTLM72S (shown)	63	4.2	\$ 3106	\$ 3399
For 78"W Tops	ATLADM-BRTLM78S	64	4.4	\$ 3130	\$ 3423
For 84"W Tops	ATLADM-BRTLM84S	66	4.5	\$ 3160	\$ 3453

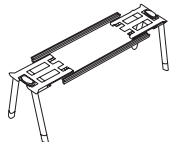

How to specify — Select the Model Number from above. ATLADM - BRTLM	1st Option: Paint Color: P1 P2 P3 See page 357 for finishes.	2nd Option: Select the Foot: CSB Casters Black CSS Casters Silver GLD Glides WHB Wheelbarrow Black (2 Glides + 2 Casters Black) WHS Wheelbarrow Silver (2 Glides + 2 Casters Silver)
	.	.

Example: ATLADM-BRTLM60S.P71.GLD

- Order base separately.
- Option for cutout only, order power units separately.
- Reference page 361 for cutout locations.
- Available in veneer or laminate tops, flat edge only.
- Edgeband color option specified separately for laminate.
- Tops ship with pilot holes for locating base.
- For use with bases on page 370.

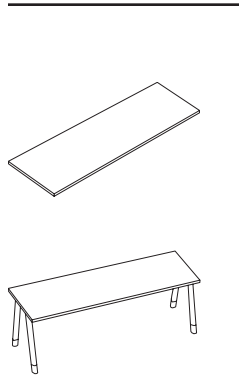

Example of Built-up Table

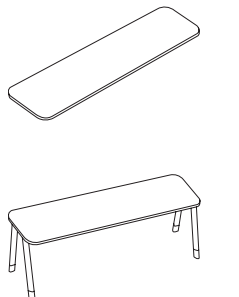

Example of Built-up Table

Description	Model Number add "L" for Laminate or "V" for Veneer	Ship Weight	Cubes	Laminate List Price			Veneer List Price	
				L1	L2	L3	V2	V3
Rectangle Fixed Tops Flat Edge								
24"D x 48"W	ATLADM-TFREC □ 2448F	36	3.3	\$ 510	\$ 537	\$ 563	\$ 1214	\$ 1324
24"D x 54"W	ATLADM-TFREC □ 2454F	40	3.7	\$ 519	\$ 546	\$ 573	\$ 1278	\$ 1394
24"D x 60"W	ATLADM-TFREC □ 2460F	45	4.1	\$ 527	\$ 554	\$ 582	\$ 1389	\$ 1515
24"D x 66"W	ATLADM-TFREC □ 2466F	49	4.5	\$ 549	\$ 577	\$ 606	\$ 1474	\$ 1608
24"D x 72"W	ATLADM-TFREC □ 2472F	53	4.9	\$ 571	\$ 601	\$ 630	\$ 1649	\$ 1799
24"D x 78"W	ATLADM-TFREC □ 2478F	58	5.3	\$ 621	\$ 653	\$ 685	\$ 1714	\$ 1870
24"D x 84"W	ATLADM-TFREC □ 2484F	62	5.7	\$ 670	\$ 706	\$ 740	\$ 1782	\$ 1944
30"D x 48"W	ATLADM-TFREC □ 3048F	45	4.1	\$ 565	\$ 594	\$ 624	\$ 1492	\$ 1628
30"D x 54"W	ATLADM-TFREC □ 3054F	50	4.6	\$ 590	\$ 621	\$ 651	\$ 1512	\$ 1649
30"D x 60"W	ATLADM-TFREC □ 3060F	56	5.0	\$ 615	\$ 647	\$ 679	\$ 1528	\$ 1667
30"D x 66"W	ATLADM-TFREC □ 3066F	61	5.5	\$ 643	\$ 676	\$ 709	\$ 1600	\$ 1745
30"D x 72"W	ATLADM-TFREC □ 3072F	67	6.0	\$ 671	\$ 707	\$ 741	\$ 1683	\$ 1836
30"D x 78"W	ATLADM-TFREC □ 3078F	72	6.5	\$ 740	\$ 779	\$ 817	\$ 1802	\$ 1966
30"D x 84"W	ATLADM-TFREC □ 3084F	78	7.0	\$ 808	\$ 850	\$ 892	\$ 1930	\$ 2105
Rounded Rectangle Fixed Tops Flat Edge								
24"D x 48"W	ATLADM-TFRREC □ 2448F	36	3.3	\$ 561	\$ 590	\$ 619	\$ 1336	\$ 1457
24"D x 54"W	ATLADM-TFRREC □ 2454F	40	3.7	\$ 571	\$ 601	\$ 630	\$ 1405	\$ 1533
24"D x 60"W	ATLADM-TFRREC □ 2460F	45	4.1	\$ 580	\$ 610	\$ 640	\$ 1527	\$ 1666
24"D x 66"W	ATLADM-TFRREC □ 2466F	49	4.5	\$ 604	\$ 635	\$ 666	\$ 1622	\$ 1769
24"D x 72"W	ATLADM-TFRREC □ 2472F	53	4.9	\$ 628	\$ 660	\$ 693	\$ 1814	\$ 1979
24"D x 78"W	ATLADM-TFRREC □ 2478F	58	5.3	\$ 683	\$ 719	\$ 754	\$ 1886	\$ 2057
24"D x 84"W	ATLADM-TFRREC □ 2484F	62	5.7	\$ 737	\$ 776	\$ 814	\$ 1961	\$ 2139
30"D x 48"W	ATLADM-TFRREC □ 3048F	45	4.1	\$ 622	\$ 654	\$ 686	\$ 1642	\$ 1791
30"D x 54"W	ATLADM-TFRREC □ 3054F	50	4.6	\$ 649	\$ 682	\$ 716	\$ 1664	\$ 1815
30"D x 60"W	ATLADM-TFRREC □ 3060F	56	5.0	\$ 677	\$ 713	\$ 748	\$ 1681	\$ 1834
30"D x 66"W	ATLADM-TFRREC □ 3066F	61	5.5	\$ 707	\$ 744	\$ 781	\$ 1760	\$ 1920
30"D x 72"W	ATLADM-TFRREC □ 3072F	67	6.0	\$ 738	\$ 777	\$ 815	\$ 1852	\$ 2020
30"D x 78"W	ATLADM-TFRREC □ 3078F	72	6.5	\$ 814	\$ 857	\$ 898	\$ 1982	\$ 2162
30"D x 84"W	ATLADM-TFRREC □ 3084F	78	7.0	\$ 889	\$ 935	\$ 981	\$ 2122	\$ 2315

ADMIX

<p>How to specify — Select the Model Number from above.</p> <p>ATLADM - TFR </p>	<p>1st Option: FSC Certified Wood: X Standard - No FSC F FSC Certified</p>	<p>2nd Option: Laminate/Veneer: See page 357 for finishes.</p>	<p>3rd Option: Edge (Laminate): See page 357 for finishes.</p>	<p>3rd Option: Top Finish (Veneer): FF Full Fill +\$282 OP Open Pore Low Sheen</p>	<p>4th Option: Cutout: GN No Grommet C1E 1 Bezel Mount Power</p>
--	---	---	---	---	---

Example: ATLADM-TFRECL2472F.X.LDW1.DW.GN

- Order base separately.
- Option for cutout only, order power units separately.
- Reference page 361 for cutout locations.
- Available in veneer or laminate tops, flat edge only.
- Edgeband color option specified separately for laminate.
- Tops ship with pilot holes for locating base.
- For use with bases on page 370.

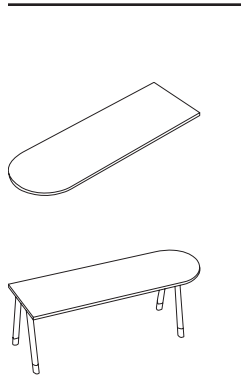

Example of Built-up Table

Description	Model Number add "L" for Laminate or "V" for Veneer	Ship Weight	Cubes	Laminate List Price			Veneer List Price		
				L1	L2	L3	V2	V3	
Half Racetrack Fixed Tops Flat Edge									
24"D x 48"W	ATLADM-TFHRAC □ 2448F	36	3.3	\$ 561	\$ 590	\$ 619	\$ 1336	\$ 1457	
24"D x 54"W	ATLADM-TFHRAC □ 2454F	40	3.7	\$ 571	\$ 601	\$ 630	\$ 1405	\$ 1533	
24"D x 60"W	ATLADM-TFHRAC □ 2460F	45	4.1	\$ 580	\$ 610	\$ 640	\$ 1527	\$ 1666	
24"D x 66"W	ATLADM-TFHRAC □ 2466F	49	4.5	\$ 604	\$ 635	\$ 666	\$ 1622	\$ 1769	
24"D x 72"W	ATLADM-TFHRAC □ 2472F	53	4.9	\$ 628	\$ 660	\$ 693	\$ 1814	\$ 1979	
24"D x 78"W	ATLADM-TFHRAC □ 2478F	58	5.3	\$ 683	\$ 719	\$ 754	\$ 1886	\$ 2057	
24"D x 84"W	ATLADM-TFHRAC □ 2484F	62	5.7	\$ 737	\$ 776	\$ 814	\$ 1961	\$ 2139	
30"D x 48"W	ATLADM-TFHRAC □ 3048F	45	4.1	\$ 622	\$ 654	\$ 686	\$ 1642	\$ 1791	
30"D x 54"W	ATLADM-TFHRAC □ 3054F	50	4.6	\$ 649	\$ 682	\$ 716	\$ 1664	\$ 1815	
30"D x 60"W	ATLADM-TFHRAC □ 3060F	56	5.0	\$ 677	\$ 713	\$ 748	\$ 1681	\$ 1834	
30"D x 66"W	ATLADM-TFHRAC □ 3066F	61	5.5	\$ 707	\$ 744	\$ 781	\$ 1760	\$ 1920	
30"D x 72"W	ATLADM-TFHRAC □ 3072F	67	6.0	\$ 738	\$ 777	\$ 815	\$ 1852	\$ 2020	
30"D x 78"W	ATLADM-TFHRAC □ 3078F	72	6.5	\$ 814	\$ 857	\$ 898	\$ 1982	\$ 2162	
30"D x 84"W	ATLADM-TFHRAC □ 3084F	78	7.0	\$ 889	\$ 935	\$ 981	\$ 2122	\$ 2315	

ADMIX

<p>How to specify — Select the Model Number from above.</p>	<p>1st Option: FSC Certified Wood: X Standard - No FSC F FSC Certified</p>	<p>2nd Option: Laminate/Veneer: See page 357 for finishes.</p>	<p>3rd Option: Edge (Laminate): See page 357 for finishes.</p>	<p>3rd Option: Top Finish (Veneer): FF Full Fill +\$282 OP Open Pore Low Sheen</p>	<p>4th Option: Cutout: GN No Grommet C1E 1 Bezel Mount Power</p>
<p>ATLADM - TFHRAC</p>					

Example: ATLADM-TFHRACL2472F.X.LDW1.DW.GN

- Connector tops available in 45, 90, and 120 degree angles.
- Flat brackets included to connect to adjoining tops.
- Intended to be used with flat end tops only — Ex: Rectangular and Half Racetrack on pages 365-366.
- 120 degree top includes qty 1 center leg.
- For use with Rectangular and Half Racetrack tops on pages 365-366.
- Applications utilizing Corner Connector Tops will not have wood grain alignment.

Description	Model Number add "L" for Laminate or "V" for Veneer	Ship Weight	Cubes	Laminate List Price			Veneer List Price	
				L1	L2	L3	V2	V3
Corner Connector Tops								
45° Corner Top 24"D	ATLADM-TCNR45 □ 24F (shown)	18	1.8	\$ 672	\$ 708	\$ 742	\$ 999	\$ 1090
90° Corner Top 24"D	ATLADM-TCNR90 □ 24F (shown)	18	1.8	\$ 790	\$ 832	\$ 872	\$ 1174	\$ 1281
120° Corner Top w/ Leg 24"D	ATLADM-TCNR120 □ 24FX	18	1.8	\$ 1334	\$ 1381	\$ 1428	\$ 1819	\$ 1984
45° Corner Top 30"D	ATLADM-TCNR45 □ 30F	18	1.8	\$ 777	\$ 818	\$ 858	\$ 1155	\$ 1260
90° Corner Top 30"D	ATLADM-TCNR90 □ 30F	18	1.8	\$ 914	\$ 962	\$ 1008	\$ 1358	\$ 1481
120° Corner Top w/ Leg 30"D	ATLADM-NR120 □ 30FX (shown)	18	1.8	\$ 1476	\$ 1531	\$ 1585	\$ 2030	\$ 2214

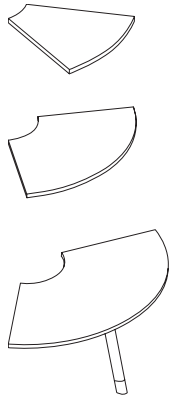

ADMIX

<p>How to specify — Select the Model Number from above.</p> <p>AT LADM - TCNR .</p>	<p>1st Option: FSC Certified Wood: X Standard - No FSC F FSC Certified</p> <p> .</p>	<p>2nd Option: Laminate/Veneer: See page 357 for finishes.</p> <p> .</p>	<p>3rd Option: Edge (Laminate): See page 357 for finishes.</p> <p> .</p>	<p>3rd Option: Top Finish (Veneer): FF Full Fill +\$282 OP Open Pore Low Sheen</p> <p> </p>
--	--	--	--	--

Example: ATLADM-TCNR45L24F.X.LDW1.DW

- Order base separately.
- Option for cutout only, order power units separately.
- Reference page 361 for cutout locations.
- Available in veneer or laminate tops, flat or knife edge.
- Edgeband color option specified separately for laminate.
- Tops ship with pilot holes for locating base.
- For use with bases on page 370.

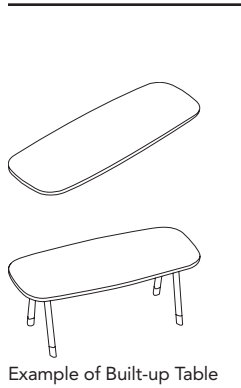

Example of Built-up Table

Description	Model Number add "L" for Laminate or "V" for Veneer	Ship Weight	Cubes	Laminate List Price			Veneer List Price	
				L1	L2	L3	V2	V3
Boat Fixed Tops Flat Edge								
24"D x 60"W	ATLADM-TFBOAT □ 2460F	45	4.1	\$ 580	\$ 610	\$ 640	\$ 1527	\$ 1666
24"D x 66"W	ATLADM-TFBOAT □ 2466F	49	4.5	\$ 604	\$ 635	\$ 666	\$ 1622	\$ 1769
24"D x 72"W	ATLADM-TFBOAT □ 2472F	53	4.9	\$ 628	\$ 660	\$ 693	\$ 1814	\$ 1979
24"D x 78"W	ATLADM-TFBOAT □ 2478F	58	5.3	\$ 683	\$ 719	\$ 754	\$ 1886	\$ 2057
24"D x 84"W	ATLADM-TFBOAT □ 2484F	62	5.7	\$ 737	\$ 776	\$ 814	\$ 1961	\$ 2139
30"D x 60"W	ATLADM-TFBOAT □ 3060F	56	5.0	\$ 677	\$ 713	\$ 748	\$ 1681	\$ 1834
30"D x 66"W	ATLADM-TFBOAT □ 3066F	61	5.5	\$ 707	\$ 744	\$ 781	\$ 1760	\$ 1920
30"D x 72"W	ATLADM-TFBOAT □ 3072F	67	6.0	\$ 738	\$ 777	\$ 815	\$ 1852	\$ 2020
30"D x 78"W	ATLADM-TFBOAT □ 3078F	72	6.5	\$ 814	\$ 857	\$ 898	\$ 1982	\$ 2162
30"D x 84"W	ATLADM-TFBOAT □ 3084F	78	7.0	\$ 889	\$ 935	\$ 981	\$ 2122	\$ 2315
Boat Fixed Tops Knife Edge								
24"D x 60"W	ATLADM-TFBOAT □ 2460K	45	4.1	\$ 1580	\$ 1662	\$ 1743	\$ 2517	\$ 2746
24"D x 66"W	ATLADM-TFBOAT □ 2466K	49	4.5	\$ 1604	\$ 1687	\$ 1769	\$ 2612	\$ 2849
24"D x 72"W	ATLADM-TFBOAT □ 2472K	53	4.9	\$ 1628	\$ 1712	\$ 1796	\$ 2804	\$ 3059
24"D x 78"W	ATLADM-TFBOAT □ 2478K	58	5.3	\$ 1683	\$ 1770	\$ 1857	\$ 2876	\$ 3137
24"D x 84"W	ATLADM-TFBOAT □ 2484K	62	5.7	\$ 1737	\$ 1827	\$ 1917	\$ 2951	\$ 3219
30"D x 60"W	ATLADM-TFBOAT □ 3060K	56	5.0	\$ 1677	\$ 1764	\$ 1851	\$ 2671	\$ 2914
30"D x 66"W	ATLADM-TFBOAT □ 3066K	61	5.5	\$ 1707	\$ 1795	\$ 1884	\$ 2750	\$ 3000
30"D x 72"W	ATLADM-TFBOAT □ 3072K	67	6.0	\$ 1738	\$ 1828	\$ 1918	\$ 2842	\$ 3100
30"D x 78"W	ATLADM-TFBOAT □ 3078K	72	6.5	\$ 1814	\$ 1908	\$ 2001	\$ 2972	\$ 3242
30"D x 84"W	ATLADM-TFBOAT □ 3084K	78	7.0	\$ 1889	\$ 1986	\$ 2084	\$ 3112	\$ 3395

ADMIX

<p>How to specify — Select the Model Number from above.</p> <p>ATLADM - TFBOAT</p>	<p>1st Option: FSC Certified Wood: X Standard - No FSC F FSC Certified</p>	<p>2nd Option: Laminate/Veneer: See page 357 for finishes.</p>	<p>3rd Option: Edge (Laminate): See page 357 for finishes.</p>	<p>3rd Option: Top Finish (Veneer): FF Full Fill +\$282 OP Open Pore Low Sheen</p>	<p>4th Option: Cutout: GN No Grommet C1E 1 Bezel Mount Power</p>
---	---	---	---	---	---

Example: ATLADM-TFBOATL2460F.LDW1.DW.GN

- Order base separately.
- Option for cutout only, order power units separately.
- Reference page 361 for cutout locations.
- Available in veneer or laminate tops, flat or knife edge.
- Edgeband color option specified separately for laminate.
- Tops ship with pilot holes for locating base.
- For use with bases on page 370.

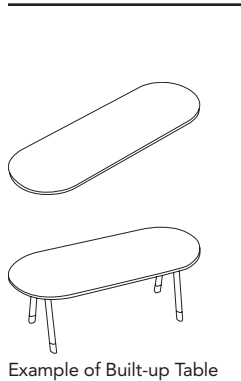

Example of Built-up Table

Description	Model Number add "L" for Laminate or "V" for Veneer	Ship Weight	Cubes	Laminate List Price			Veneer List Price	
				L1	L2	L3	V2	V3
Racetrack Fixed Tops Flat Edge								
24"D x 48"W	ATLADM-TFRACE □ 2448F	36	3.3	\$ 561	\$ 590	\$ 619	\$ 1336	\$ 1457
24"D x 54"W	ATLADM-TFRACE □ 2454F	40	3.7	\$ 571	\$ 601	\$ 630	\$ 1405	\$ 1533
24"D x 60"W	ATLADM-TFRACE □ 2460F	45	4.1	\$ 580	\$ 610	\$ 640	\$ 1527	\$ 1666
24"D x 66"W	ATLADM-TFRACE □ 2466F	49	4.5	\$ 604	\$ 635	\$ 666	\$ 1622	\$ 1769
24"D x 72"W	ATLADM-TFRACE □ 2472F	53	4.9	\$ 628	\$ 660	\$ 693	\$ 1814	\$ 1979
24"D x 78"W	ATLADM-TFRACE □ 2478F	58	5.3	\$ 683	\$ 719	\$ 754	\$ 1886	\$ 2057
24"D x 84"W	ATLADM-TFRACE □ 2484F	62	5.7	\$ 737	\$ 776	\$ 814	\$ 1961	\$ 2139
30"D x 48"W	ATLADM-TFRACE □ 3048F	45	4.1	\$ 622	\$ 654	\$ 686	\$ 1642	\$ 1791
30"D x 54"W	ATLADM-TFRACE □ 3054F	50	4.6	\$ 649	\$ 682	\$ 716	\$ 1664	\$ 1815
30"D x 60"W	ATLADM-TFRACE □ 3060F	56	5.0	\$ 677	\$ 713	\$ 748	\$ 1681	\$ 1834
30"D x 66"W	ATLADM-TFRACE □ 3066F	61	5.5	\$ 707	\$ 744	\$ 781	\$ 1760	\$ 1920
30"D x 72"W	ATLADM-TFRACE □ 3072F	67	6.0	\$ 738	\$ 777	\$ 815	\$ 1852	\$ 2020
30"D x 78"W	ATLADM-TFRACE □ 3078F	72	6.5	\$ 814	\$ 857	\$ 898	\$ 1982	\$ 2162
30"D x 84"W	ATLADM-TFRACE □ 3084F	78	7.0	\$ 889	\$ 935	\$ 981	\$ 2122	\$ 2315
Racetrack Fixed Tops Knife Edge								
24"D x 48"W	ATLADM-TFRACE □ 2448K	36	3.3	\$ 1561	\$ 1642	\$ 1722	\$ 2326	\$ 2537
24"D x 54"W	ATLADM-TFRACE □ 2454K	40	3.7	\$ 1571	\$ 1653	\$ 1733	\$ 2395	\$ 2613
24"D x 60"W	ATLADM-TFRACE □ 2460K	45	4.1	\$ 1580	\$ 1662	\$ 1743	\$ 2517	\$ 2746
24"D x 66"W	ATLADM-TFRACE □ 2466K	49	4.5	\$ 1604	\$ 1687	\$ 1769	\$ 2612	\$ 2849
24"D x 72"W	ATLADM-TFRACE □ 2472K	53	4.9	\$ 1628	\$ 1712	\$ 1796	\$ 2804	\$ 3059
24"D x 78"W	ATLADM-TFRACE □ 2478K	58	5.3	\$ 1683	\$ 1770	\$ 1857	\$ 2876	\$ 3137
24"D x 84"W	ATLADM-TFRACE □ 2484K	62	5.7	\$ 1737	\$ 1827	\$ 1917	\$ 2951	\$ 3219
30"D x 48"W	ATLADM-TFRACE □ 3048K	45	4.1	\$ 1622	\$ 1706	\$ 1789	\$ 2632	\$ 2871
30"D x 54"W	ATLADM-TFRACE □ 3054K	50	4.6	\$ 1649	\$ 1734	\$ 1819	\$ 2654	\$ 2895
30"D x 60"W	ATLADM-TFRACE □ 3060K	56	5.0	\$ 1677	\$ 1764	\$ 1851	\$ 2671	\$ 2914
30"D x 66"W	ATLADM-TFRACE □ 3066K	61	5.5	\$ 1707	\$ 1795	\$ 1884	\$ 2750	\$ 3000
30"D x 72"W	ATLADM-TFRACE □ 3072K	67	6.0	\$ 1738	\$ 1828	\$ 1918	\$ 2842	\$ 3100
30"D x 78"W	ATLADM-TFRACE □ 3078K	72	6.5	\$ 1814	\$ 1908	\$ 2001	\$ 2972	\$ 3242
30"D x 84"W	ATLADM-TFRACE □ 3084K	78	7.0	\$ 1889	\$ 1986	\$ 2084	\$ 3112	\$ 3395

ADMIX

<p>How to specify — Select the Model Number from above.</p> <p>ATLADM - TFRACE</p>	<p>1st Option: FSC Certified Wood: X Standard - No FSC F FSC Certified</p>	<p>2nd Option: Laminate/Veneer: See page 357 for finishes.</p>	<p>3rd Option: Edge (Laminate): See page 357 for finishes.</p>	<p>3rd Option: Top Finish (Veneer): FF Full Fill +\$282 OP Open Pore Low Sheen</p>	<p>4th Option: Cutout: GN No Grommet C1E 1 Bezel Mount Power</p>
---	---	---	---	---	---

Example: ATLADM-TFRACEL2460F.X.LDW1.DW.GN

- Base includes external stiffeners for tops (if required).
- Base ships knocked down.
- Outset bases to only be used for tops with flat side on both ends — Ex: Rectangular and Rounded Rectangular.
- Inset dimension for each top size: 48"W = 6.0", 54"W = 7.0", 60"W = 8.75", 66"W = 10.0", 72"W = 11.0", 78"W = 12.0", 84"W = 12.0"
- For use with tops on pages [365-369](#).

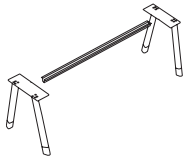

Description	Model	Ship Weight	Cubes	List Price	
				P1	P2
Fixed Base Outset Legs — Standard Height					
For 48" Table Tops	ATLADM-BRFXOUTM48S	38	2.6	\$ 1700	\$ 1876
For 54" Table Tops	ATLADM-BRFXOUTM54S	41	2.9	\$ 1786	\$ 1962
For 60" Table Tops	ATLADM-BRFXOUTM60S	42	3.0	\$ 1799	\$ 1975
For 66" Table Tops	ATLADM-BRFXOUTM66S	43	3.0	\$ 1806	\$ 1982
For 72" Table Tops	ATLADM-BRFXOUTM72S (shown)	43	3.1	\$ 1824	\$ 2000
For 78" Table Tops	ATLADM-BRFXOUTM78S	44	3.1	\$ 1833	\$ 2009
For 84" Table Tops	ATLADM-BRFXOUTM84S	44	3.2	\$ 1845	\$ 2021
Fixed Base Inset Legs — Standard Height					
For 48" Table Tops	ATLADM-BRFXINM48S	38	2.6	\$ 1700	\$ 1876
For 54" Table Tops	ATLADM-BRFXINM54S	38	2.6	\$ 1700	\$ 1876
For 60" Table Tops	ATLADM-BRFXINM60S	38	2.6	\$ 1700	\$ 1876
For 66" Table Tops	ATLADM-BRFXINM66S	38	2.6	\$ 1700	\$ 1876
For 72" Table Tops	ATLADM-BRFXINM72S	38	2.6	\$ 1700	\$ 1876
For 78" Table Tops	ATLADM-BRFXINM78S	41	2.9	\$ 1786	\$ 1962
For 84" Table Tops	ATLADM-BRFXINM84S	42	3.0	\$ 1799	\$ 1975

ADMIX

<p>How to specify — Select the Model Number from above.</p>	<p>1st Option: Paint Color: P1 P2 P3 See page 357 for finishes.</p>	<p>2nd Option: Select the Foot: CSB Casters Black CSS Casters Silver GLD Glides WHB Wheelbarrow Black (2 Glides + 2 Casters Black) WHS Wheelbarrow Silver (2 Glides + 2 Casters Silver)</p>
<p>ATLADM - BRFX .</p>	<p> .</p>	<p> .</p>

Example: ATLADM-BRFXOUTM48S.P1.GLD

- Modesty panels include angle brackets for top attachment.
- Order modesty to match top size. Non-Rectangular tops may require ordering one size smaller.
- Grain runs horizontal on all sizes.
- For use with standard height reconfigurable and personal tables.

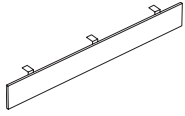

Description	Model Number add "L" for Laminate or "V" for Veneer	Ship Weight	Cubes	Laminate List Price			Veneer List Price	
				L1	L2	L3	V2	V3
Modesty Panels								
36"	ATLADM-MOD □ 36	7	1.1	\$ 426	\$ 448	\$ 471	\$ 548	\$ 598
42"	ATLADM-MOD □ 42	8	1.3	\$ 479	\$ 504	\$ 529	\$ 609	\$ 664
48"	ATLADM-MOD □ 48	9	1.4	\$ 541	\$ 569	\$ 597	\$ 699	\$ 762
54"	ATLADM-MOD □ 54	11	1.6	\$ 587	\$ 617	\$ 648	\$ 744	\$ 812
60"	ATLADM-MOD □ 60	12	1.8	\$ 613	\$ 645	\$ 676	\$ 824	\$ 899
66"	ATLADM-MOD □ 66	13	1.9	\$ 641	\$ 674	\$ 707	\$ 872	\$ 951
72"	ATLADM-MOD □ 72 (shown)	14	2.1	\$ 671	\$ 707	\$ 741	\$ 951	\$ 1037
78"	ATLADM-MOD □ 78	15	2.3	\$ 705	\$ 742	\$ 779	\$ 999	\$ 1090
84"	ATLADM-MOD □ 84	16	2.5	\$ 740	\$ 779	\$ 817	\$ 1049	\$ 1144

ADMIX

<p><i>How to specify —</i> Select the Model Number from above.</p> <p>ATLADM - MOD .</p>	<p><i>1st Option:</i> FSC Certified Wood: X Standard - No FSC F FSC Certified</p> <p> .</p>	<p><i>2nd Option:</i> Laminate/Veneer: See page 357 for finishes.</p> <p> </p>
--	--	--

Example: ATLADM-MODL36.X.LDW1

- Order base separately.
- Option for cutout only, order power units separately.
- Reference page 361 for cutout locations.
- Available in veneer or laminate tops, flat or knife edge.
- Edgeband color option specified separately for laminate.
- Tops ship with pilot holes for locating base.
- For use with bases on pages 376-377.
- Tops 120" or greater are 2 piece. Adjoining seams are not edgebanded.

Description	Model Number add "L" for Laminate or "V" for Veneer	Ship Weight	Cubes	Laminate List Price			Veneer List Price	
				L1	L2	L3	V2	V3
Rectangle Tops Flat								
36"D x 60"W	ATLADM-TMREC 3660F	67	6.0	\$ 675	\$ 711	\$ 746	\$ 1996	\$ 2177
36"D x 72"W	ATLADM-TMREC 3672F	80	7.1	\$ 783	\$ 824	\$ 864	\$ 2198	\$ 2398
36"D x 84"W	ATLADM-TMREC 3684F	94	8.2	\$ 992	\$ 1044	\$ 1094	\$ 2543	\$ 2774
36"D x 96"W	ATLADM-TMREC 3696F	107	9.4	\$ 1149	\$ 1208	\$ 1268	\$ 3018	\$ 3292
36"D x 108"W	ATLADM-TMREC 36108F	120	10.5	\$ 1443	\$ 1518	\$ 1592	\$ 3485	\$ 3802
36"D x 120"W	ATLADM-TMREC 36120F	134	11.6	\$ 1737	\$ 1827	\$ 1917	\$ 3953	\$ 4312
36"D x 144"W	ATLADM-TMREC 36144F	160	13.9	\$ 1974	\$ 2076	\$ 2177	\$ 4759	\$ 5192
42"D x 72"W	ATLADM-TMREC 4272F	94	8.2	\$ 1069	\$ 1124	\$ 1180	\$ 3338	\$ 3641
42"D x 84"W	ATLADM-TMREC 4284F	109	9.5	\$ 1201	\$ 1263	\$ 1325	\$ 3992	\$ 4355
42"D x 96"W	ATLADM-TMREC 4296F	125	10.8	\$ 1229	\$ 1292	\$ 1356	\$ 4176	\$ 4556
42"D x 108"W	ATLADM-TMREC 42108F	140	12.1	\$ 1593	\$ 1676	\$ 1757	\$ 5144	\$ 5612
42"D x 120"W	ATLADM-TMREC 42120F	156	8.8	\$ 1956	\$ 2057	\$ 2158	\$ 5554	\$ 6059
42"D x 144"W	ATLADM-TMREC 42144F	187	10.5	\$ 2221	\$ 2336	\$ 2450	\$ 7035	\$ 7674
48"D x 72"W	ATLADM-TMREC 4872F	107	9.3	\$ 1167	\$ 1227	\$ 1288	\$ 3663	\$ 3996
48"D x 84"W	ATLADM-TMREC 4884F	125	10.8	\$ 1387	\$ 1459	\$ 1531	\$ 4392	\$ 4791
48"D x 96"W	ATLADM-TMREC 4896F	143	12.2	\$ 1421	\$ 1495	\$ 1568	\$ 4727	\$ 5157
48"D x 108"W	ATLADM-TMREC 48108F	160	13.7	\$ 1689	\$ 1776	\$ 1864	\$ 5643	\$ 6156
48"D x 120"W	ATLADM-TMREC 48120F	178	10.0	\$ 1956	\$ 2057	\$ 2158	\$ 6454	\$ 7041
48"D x 144"W	ATLADM-TMREC 48144F	214	11.9	\$ 2221	\$ 2336	\$ 2450	\$ 7963	\$ 8687

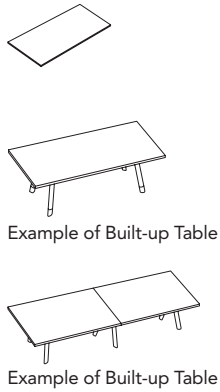

Rectangle Tops Knife

36"D x 60"W	ATLADM-TMREC 3660K	67	6.0	\$ 1875	\$ 1972	\$ 2069	\$ 3184	\$ 3473
36"D x 72"W	ATLADM-TMREC 3672K	80	7.1	\$ 1983	\$ 2085	\$ 2187	\$ 3386	\$ 3694
36"D x 84"W	ATLADM-TMREC 3684K	94	8.2	\$ 2192	\$ 2306	\$ 2418	\$ 3731	\$ 4070
36"D x 96"W	ATLADM-TMREC 3696K	107	9.4	\$ 2349	\$ 2470	\$ 2592	\$ 4206	\$ 4588
36"D x 108"W	ATLADM-TMREC 36108K	120	10.5	\$ 2643	\$ 2779	\$ 2915	\$ 4673	\$ 5098
36"D x 120"W	ATLADM-TMREC 36120K	134	11.6	\$ 3137	\$ 3299	\$ 3461	\$ 5339	\$ 5824
36"D x 144"W	ATLADM-TMREC 36144K	160	13.9	\$ 3374	\$ 3549	\$ 3722	\$ 6145	\$ 6704
42"D x 72"W	ATLADM-TMREC 4272K	94	8.2	\$ 2369	\$ 2491	\$ 2614	\$ 4625	\$ 5045
42"D x 84"W	ATLADM-TMREC 4284K	109	9.5	\$ 2501	\$ 2630	\$ 2759	\$ 5279	\$ 5759
42"D x 96"W	ATLADM-TMREC 4296K	125	10.8	\$ 2529	\$ 2659	\$ 2790	\$ 5463	\$ 5960
42"D x 108"W	ATLADM-TMREC 42108K	140	12.1	\$ 2893	\$ 3043	\$ 3191	\$ 6431	\$ 7016
42"D x 120"W	ATLADM-TMREC 42120K	156	8.8	\$ 3456	\$ 3635	\$ 3813	\$ 7039	\$ 7679
42"D x 144"W	ATLADM-TMREC 42144K	187	10.5	\$ 3721	\$ 3913	\$ 4105	\$ 8520	\$ 9294
48"D x 72"W	ATLADM-TMREC 4872K	107	9.3	\$ 2567	\$ 2699	\$ 2832	\$ 5049	\$ 5508
48"D x 84"W	ATLADM-TMREC 4884K	125	10.8	\$ 2787	\$ 2931	\$ 3075	\$ 5778	\$ 6303
48"D x 96"W	ATLADM-TMREC 4896K	143	12.2	\$ 2821	\$ 2967	\$ 3112	\$ 6113	\$ 6669
48"D x 108"W	ATLADM-TMREC 48108K	160	13.7	\$ 3089	\$ 3248	\$ 3408	\$ 7029	\$ 7668
48"D x 120"W	ATLADM-TMREC 48120K	178	10.0	\$ 3556	\$ 3740	\$ 3923	\$ 8038	\$ 8769
48"D x 144"W	ATLADM-TMREC 48144K	214	11.9	\$ 3821	\$ 4018	\$ 4215	\$ 9547	\$ 10415

Note: Tops 120" or greater are two pieces.

<p>How to specify — Select the Model Number from above.</p> <p>ATLADM - TMREC</p>	<p>1st Option: FSC Certified Wood: X Standard - No FSC F FSC Certified</p>	<p>2nd Option: Laminate/Veneer: See page 357 for finishes.</p>	<p>3rd Option: Edge (Laminate): See page 357 for finishes.</p>	<p>3rd Option: Top Finish (Veneer): FF Full Fill +\$282 (up to 120"W) +\$450 (for 144"W) OP Open Pore Low Sheen</p>	<p>4th Option: Cutout: GN No Grommet C1E 1 Bezel Mount Power C1TM 1 Tech Module C2E 2 Bezel Mount Power C2TM 2 Tech Module Note: C2 options for tables 108"W and greater.</p>
--	---	---	---	--	--

Example: ATLADM-TMRECL3660F.X.LDW1.DW.GN

- Order base separately.
- Option for cutout only, order power units separately.
- Reference page 361 for cutout locations.

- Available in veneer or laminate tops, flat or knife edge.
- Edgeband color option specified separately for laminate.
- Tops ship with pilot holes for locating base.

- For use with bases on pages 376-377.
- Tops 120" or greater are 2 piece. Adjoining seams are not edgebanded.

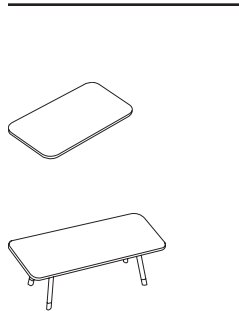

Example of Built-up Table

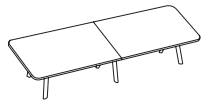

Example of Built-up Table

Description	Model Number add "L" for Laminate or "V" for Veneer	Ship Weight	Cubes	Laminate List Price			Veneer List Price	
				L1	L2	L3	V2	V3
Rounded Rectangle Tops Flat								
36"D x 60"W	ATLADM-TMRREC □ 3660F	67	6.0	\$ 743	\$ 782	\$ 820	\$ 2196	\$ 2396
36"D x 72"W	ATLADM-TMRREC □ 3672F	80	7.1	\$ 861	\$ 906	\$ 950	\$ 2417	\$ 2637
36"D x 84"W	ATLADM-TMRREC □ 3684F	94	8.2	\$ 1091	\$ 1148	\$ 1204	\$ 2797	\$ 3051
36"D x 96"W	ATLADM-TMRREC □ 3696F	107	9.4	\$ 1264	\$ 1329	\$ 1394	\$ 3319	\$ 3621
36"D x 108"W	ATLADM-TMRREC □ 36108F	120	10.5	\$ 1587	\$ 1669	\$ 1751	\$ 3834	\$ 4182
36"D x 120"W	ATLADM-TMRREC □ 36120F	134	11.6	\$ 1911	\$ 2010	\$ 2108	\$ 4348	\$ 4743
36"D x 144"W	ATLADM-TMRREC □ 36144F	160	13.9	\$ 2171	\$ 2284	\$ 2395	\$ 5235	\$ 5711
42"D x 72"W	ATLADM-TMRREC □ 4272F	94	8.2	\$ 1176	\$ 1237	\$ 1298	\$ 3672	\$ 4006
42"D x 84"W	ATLADM-TMRREC □ 4284F	109	9.5	\$ 1321	\$ 1389	\$ 1457	\$ 4392	\$ 4791
42"D x 96"W	ATLADM-TMRREC □ 4296F	125	10.8	\$ 1352	\$ 1423	\$ 1492	\$ 4594	\$ 5012
42"D x 108"W	ATLADM-TMRREC □ 42108F	140	12.1	\$ 1752	\$ 1843	\$ 1933	\$ 5659	\$ 6173
42"D x 120"W	ATLADM-TMRREC □ 42120F	156	8.8	\$ 2152	\$ 2264	\$ 2374	\$ 6110	\$ 6665
42"D x 144"W	ATLADM-TMRREC □ 42144F	187	10.5	\$ 2443	\$ 2569	\$ 2695	\$ 7739	\$ 8442
48"D x 72"W	ATLADM-TMRREC □ 4872F	107	9.3	\$ 1284	\$ 1350	\$ 1416	\$ 4030	\$ 4396
48"D x 84"W	ATLADM-TMRREC □ 4884F	125	10.8	\$ 1526	\$ 1605	\$ 1684	\$ 4832	\$ 5271
48"D x 96"W	ATLADM-TMRREC □ 4896F	143	12.2	\$ 1563	\$ 1644	\$ 1724	\$ 5199	\$ 5672
48"D x 108"W	ATLADM-TMRREC □ 48108F	160	13.7	\$ 1858	\$ 1954	\$ 2050	\$ 6208	\$ 6772
48"D x 120"W	ATLADM-TMRREC □ 48120F	178	10.0	\$ 2152	\$ 2264	\$ 2374	\$ 7099	\$ 7744
48"D x 144"W	ATLADM-TMRREC □ 48144F	214	11.9	\$ 2443	\$ 2569	\$ 2695	\$ 8760	\$ 9556

Rounded Rectangle Tops Knife								
36"D x 60"W	ATLADM-TMRREC □ 3660K	67	6.0	\$ 2063	\$ 2170	\$ 2276	\$ 3503	\$ 3821
36"D x 72"W	ATLADM-TMRREC □ 3672K	80	7.1	\$ 2181	\$ 2294	\$ 2406	\$ 3724	\$ 4062
36"D x 84"W	ATLADM-TMRREC □ 3684K	94	8.2	\$ 2411	\$ 2536	\$ 2660	\$ 4103	\$ 4476
36"D x 96"W	ATLADM-TMRREC □ 3696K	107	9.4	\$ 2584	\$ 2717	\$ 2850	\$ 4626	\$ 5046
36"D x 108"W	ATLADM-TMRREC □ 36108K	120	10.5	\$ 2907	\$ 3057	\$ 3207	\$ 5141	\$ 5608
36"D x 120"W	ATLADM-TMRREC □ 36120K	134	11.6	\$ 3451	\$ 3630	\$ 3807	\$ 5872	\$ 6406
36"D x 144"W	ATLADM-TMRREC □ 36144K	160	13.9	\$ 3711	\$ 3903	\$ 4094	\$ 6760	\$ 7374
42"D x 72"W	ATLADM-TMRREC □ 4272K	94	8.2	\$ 2606	\$ 2740	\$ 2875	\$ 5088	\$ 5550
42"D x 84"W	ATLADM-TMRREC □ 4284K	109	9.5	\$ 2751	\$ 2894	\$ 3035	\$ 5807	\$ 6335
42"D x 96"W	ATLADM-TMRREC □ 4296K	125	10.8	\$ 2782	\$ 2926	\$ 3069	\$ 6010	\$ 6556
42"D x 108"W	ATLADM-TMRREC □ 42108K	140	12.1	\$ 3182	\$ 3346	\$ 3510	\$ 7075	\$ 7718
42"D x 120"W	ATLADM-TMRREC □ 42120K	156	8.8	\$ 3802	\$ 3998	\$ 4194	\$ 7743	\$ 8447
42"D x 144"W	ATLADM-TMRREC □ 42144K	187	10.5	\$ 4093	\$ 4305	\$ 4515	\$ 9372	\$ 10224
48"D x 72"W	ATLADM-TMRREC □ 4872K	107	9.3	\$ 2824	\$ 2970	\$ 3115	\$ 5554	\$ 6059
48"D x 84"W	ATLADM-TMRREC □ 4884K	125	10.8	\$ 3066	\$ 3224	\$ 3383	\$ 6356	\$ 6934
48"D x 96"W	ATLADM-TMRREC □ 4896K	143	12.2	\$ 3103	\$ 3263	\$ 3423	\$ 6724	\$ 7335
48"D x 108"W	ATLADM-TMRREC □ 48108K	160	13.7	\$ 3398	\$ 3574	\$ 3749	\$ 7732	\$ 8435
48"D x 120"W	ATLADM-TMRREC □ 48120K	178	10.0	\$ 3912	\$ 4114	\$ 4315	\$ 8841	\$ 9645
48"D x 144"W	ATLADM-TMRREC □ 48144K	214	11.9	\$ 4203	\$ 4420	\$ 4636	\$ 10502	\$ 11457

Note: Tops 120" or greater are two pieces.

<p>How to specify — Select the Model Number from above.</p> <p>ATLADM - TMRREC</p>	<p>1st Option: FSC Certified Wood: X Standard - No FSC F FSC Certified</p>	<p>2nd Option: Laminate/Veneer: See page 357 for finishes.</p>	<p>3rd Option: Edge (Laminate): See page 357 for finishes.</p>	<p>3rd Option: Top Finish (Veneer): FF Full Fill +\$282 (up to 120"W) +\$450 (for 144"W) OP Open Pore Low Sheen</p>	<p>4th Option: Cutout: GN No Grommet C1E 1 Bezel Mount Power C1TM 1 Tech Module C2E 2 Bezel Mount Power C2TM 2 Tech Module Note: C2 options for tables 108"W and greater.</p>
---	---	---	---	--	--

Example: ATLADM-TMRRECL3660F.X.LDW1.DW.GN

- Order base separately.
- Option for cutout only, order power units separately.
- Reference page 361 for cutout locations.

- Available in veneer or laminate tops, flat or knife edge.
- Edgeband color option specified separately for laminate.
- Tops ship with pilot holes for locating base.

- For use with bases on pages 376-377.
- Tops 120" or greater are 2 piece. Adjoining seams are not edgebanded.

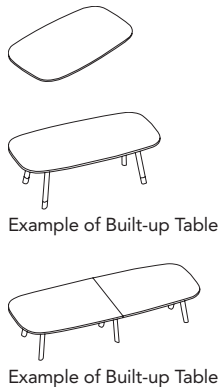

Description	Model Number add "L" for Laminate or "V" for Veneer	Ship Weight	Cubes	Laminate List Price			Veneer List Price	
				L1	L2	L3	V2	V3
Boat Tops Flat								
36"D x 60"W	ATLADM-TMBOAT □ 3660F	67	6.0	\$ 743	\$ 782	\$ 820	\$ 2196	\$ 2396
36"D x 72"W	ATLADM-TMBOAT □ 3672F	80	7.1	\$ 861	\$ 906	\$ 950	\$ 2417	\$ 2637
36"D x 84"W	ATLADM-TMBOAT □ 3684F	94	8.2	\$ 1091	\$ 1148	\$ 1204	\$ 2797	\$ 3051
36"D x 96"W	ATLADM-TMBOAT □ 3696F	107	9.4	\$ 1264	\$ 1329	\$ 1394	\$ 3319	\$ 3621
36"D x 108"W	ATLADM-TMBOAT □ 36108F	120	10.5	\$ 1587	\$ 1669	\$ 1751	\$ 3834	\$ 4182
36"D x 120"W	ATLADM-TMBOAT □ 36120F	134	11.6	\$ 1911	\$ 2010	\$ 2108	\$ 4348	\$ 4743
36"D x 144"W	ATLADM-TMBOAT □ 36144F	160	13.9	\$ 2171	\$ 2284	\$ 2395	\$ 5235	\$ 5711
42"D x 72"W	ATLADM-TMBOAT □ 4272F	94	8.2	\$ 1176	\$ 1237	\$ 1298	\$ 3672	\$ 4006
42"D x 84"W	ATLADM-TMBOAT □ 4284F	109	9.5	\$ 1321	\$ 1389	\$ 1457	\$ 4392	\$ 4791
42"D x 96"W	ATLADM-TMBOAT □ 4296F	125	10.8	\$ 1352	\$ 1423	\$ 1492	\$ 4594	\$ 5012
42"D x 108"W	ATLADM-TMBOAT □ 42108F	140	12.1	\$ 1752	\$ 1843	\$ 1933	\$ 5659	\$ 6173
42"D x 120"W	ATLADM-TMBOAT □ 42120F	156	8.8	\$ 2152	\$ 2264	\$ 2374	\$ 6110	\$ 6665
42"D x 144"W	ATLADM-TMBOAT □ 42144F	187	10.5	\$ 2443	\$ 2569	\$ 2695	\$ 7739	\$ 8442
48"D x 72"W	ATLADM-TMBOAT □ 4872F	107	9.3	\$ 1284	\$ 1350	\$ 1416	\$ 4030	\$ 4396
48"D x 84"W	ATLADM-TMBOAT □ 4884F	125	10.8	\$ 1526	\$ 1605	\$ 1684	\$ 4832	\$ 5271
48"D x 96"W	ATLADM-TMBOAT □ 4896F	143	12.2	\$ 1563	\$ 1644	\$ 1724	\$ 5199	\$ 5672
48"D x 108"W	ATLADM-TMBOAT □ 48108F	160	13.7	\$ 1858	\$ 1954	\$ 2050	\$ 6208	\$ 6772
48"D x 120"W	ATLADM-TMBOAT □ 48120F	178	10.0	\$ 2152	\$ 2264	\$ 2374	\$ 7099	\$ 7744
48"D x 144"W	ATLADM-TMBOAT □ 48144F	214	11.9	\$ 2443	\$ 2569	\$ 2695	\$ 8760	\$ 9556

Boat Tops Knife								
36"D x 60"W	ATLADM-TMBOAT □ 3660K	67	6.0	\$ 2063	\$ 2170	\$ 2276	\$ 3503	\$ 3821
36"D x 72"W	ATLADM-TMBOAT □ 3672K	80	7.1	\$ 2181	\$ 2294	\$ 2406	\$ 3724	\$ 4062
36"D x 84"W	ATLADM-TMBOAT □ 3684K	94	8.2	\$ 2411	\$ 2536	\$ 2660	\$ 4103	\$ 4476
36"D x 96"W	ATLADM-TMBOAT □ 3696K	107	9.4	\$ 2584	\$ 2717	\$ 2850	\$ 4626	\$ 5046
36"D x 108"W	ATLADM-TMBOAT □ 36108K	120	10.5	\$ 2907	\$ 3057	\$ 3207	\$ 5141	\$ 5608
36"D x 120"W	ATLADM-TMBOAT □ 36120K	134	11.6	\$ 3451	\$ 3630	\$ 3807	\$ 5872	\$ 6406
36"D x 144"W	ATLADM-TMBOAT □ 36144K	160	13.9	\$ 3711	\$ 3903	\$ 4094	\$ 6760	\$ 7374
42"D x 72"W	ATLADM-TMBOAT □ 4272K	94	8.2	\$ 2606	\$ 2740	\$ 2875	\$ 5088	\$ 5550
42"D x 84"W	ATLADM-TMBOAT □ 4284K	109	9.5	\$ 2751	\$ 2894	\$ 3035	\$ 5807	\$ 6335
42"D x 96"W	ATLADM-TMBOAT □ 4296K	125	10.8	\$ 2782	\$ 2926	\$ 3069	\$ 6010	\$ 6556
42"D x 108"W	ATLADM-TMBOAT □ 42108K	140	12.1	\$ 3182	\$ 3346	\$ 3510	\$ 7075	\$ 7718
42"D x 120"W	ATLADM-TMBOAT □ 42120K	156	8.8	\$ 3802	\$ 3998	\$ 4194	\$ 7743	\$ 8447
42"D x 144"W	ATLADM-TMBOAT □ 42144K	187	10.5	\$ 4093	\$ 4305	\$ 4515	\$ 9372	\$10224
48"D x 72"W	ATLADM-TMBOAT □ 4872K	107	9.3	\$ 2824	\$ 2970	\$ 3115	\$ 5554	\$ 6059
48"D x 84"W	ATLADM-TMBOAT □ 4884K	125	10.8	\$ 3066	\$ 3224	\$ 3383	\$ 6356	\$ 6934
48"D x 96"W	ATLADM-TMBOAT □ 4896K	143	12.2	\$ 3103	\$ 3263	\$ 3423	\$ 6724	\$ 7335
48"D x 108"W	ATLADM-TMBOAT □ 48108K	160	13.7	\$ 3398	\$ 3574	\$ 3749	\$ 7732	\$ 8435
48"D x 120"W	ATLADM-TMBOAT □ 48120K	178	10.0	\$ 3912	\$ 4114	\$ 4315	\$ 8841	\$ 9645
48"D x 144"W	ATLADM-TMBOAT □ 48144K	214	11.9	\$ 4203	\$ 4420	\$ 4636	\$10502	\$11457

Note: Tops 120" or greater are two pieces.

How to specify — Select the Model Number from above.	1st Option: FSC Certified Wood: X Standard - No FSC F FSC Certified	2nd Option: Laminate/Veneer: See page 357 for finishes.	3rd Option: Edge (Laminate): See page 357 for finishes.	3rd Option: Top Finish (Veneer): FF Full Fill +\$282 (up to 120"W) +\$450 (for 144"W) OP Open Pore Low Sheen	4th Option: Cutout: GN No Grommet C1E 1 Bezel Mount Power C1TM 1 Tech Module C2E 2 Bezel Mount Power C2TM 2 Tech Module Note: C2 options for tables 108"W and greater.
ATLADM - TMBOAT					

Example: ATLADM-TMBOATL3660F.X.LDW1.DW.GN

- Order base separately.
- Option for cutout only, order power units separately.
- Reference page 361 for cutout locations.

- Available in veneer or laminate tops, flat or knife edge.
- Edgeband color option specified separately for laminate.
- Tops ship with pilot holes for locating base.

- For use with bases on pages 376-377.
- Tops 120" or greater are 2 piece. Adjoining seams are not edgebanded.

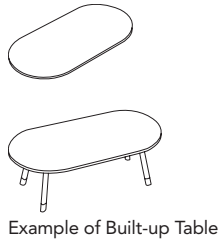

Example of Built-up Table



Example of Built-up Table

Description	Model Number add "L" for Laminate or "V" for Veneer	Ship Weight	Cubes	Laminate List Price			Veneer List Price	
				L1	L2	L3	V2	V3
Racetrack Tops Flat								
36"D x 60"W	ATLADM-TMRACE □ 3660F	67	6.0	\$ 743	\$ 782	\$ 820	\$ 2196	\$ 2396
36"D x 72"W	ATLADM-TMRACE □ 3672F	80	7.1	\$ 861	\$ 906	\$ 950	\$ 2417	\$ 2637
36"D x 84"W	ATLADM-TMRACE □ 3684F	94	8.2	\$ 1091	\$ 1148	\$ 1204	\$ 2797	\$ 3051
36"D x 96"W	ATLADM-TMRACE □ 3696F	107	9.4	\$ 1264	\$ 1329	\$ 1394	\$ 3319	\$ 3621
36"D x 108"W	ATLADM-TMRACE □ 36108F	120	10.5	\$ 1587	\$ 1669	\$ 1751	\$ 3834	\$ 4182
36"D x 120"W	ATLADM-TMRACE □ 36120F	134	11.6	\$ 1911	\$ 2010	\$ 2108	\$ 4348	\$ 4743
36"D x 144"W	ATLADM-TMRACE □ 36144F	160	13.9	\$ 2171	\$ 2284	\$ 2395	\$ 5235	\$ 5711
42"D x 72"W	ATLADM-TMRACE □ 4272F	94	8.2	\$ 1176	\$ 1237	\$ 1298	\$ 3672	\$ 4006
42"D x 84"W	ATLADM-TMRACE □ 4284F	109	9.5	\$ 1321	\$ 1389	\$ 1457	\$ 4392	\$ 4791
42"D x 96"W	ATLADM-TMRACE □ 4296F	125	10.8	\$ 1352	\$ 1423	\$ 1492	\$ 4594	\$ 5012
42"D x 108"W	ATLADM-TMRACE □ 42108F	140	12.1	\$ 1752	\$ 1843	\$ 1933	\$ 5659	\$ 6173
42"D x 120"W	ATLADM-TMRACE □ 42120F	156	8.8	\$ 2152	\$ 2264	\$ 2374	\$ 6110	\$ 6665
42"D x 144"W	ATLADM-TMRACE □ 42144F	187	10.5	\$ 2443	\$ 2569	\$ 2695	\$ 7739	\$ 8442
48"D x 72"W	ATLADM-TMRACE □ 4872F	107	9.3	\$ 1284	\$ 1350	\$ 1416	\$ 4030	\$ 4396
48"D x 84"W	ATLADM-TMRACE □ 4884F	125	10.8	\$ 1526	\$ 1605	\$ 1684	\$ 4832	\$ 5271
48"D x 96"W	ATLADM-TMRACE □ 4896F	143	12.2	\$ 1563	\$ 1644	\$ 1724	\$ 5199	\$ 5672
48"D x 108"W	ATLADM-TMRACE □ 48108F	160	13.7	\$ 1858	\$ 1954	\$ 2050	\$ 6208	\$ 6772
48"D x 120"W	ATLADM-TMRACE □ 48120F	178	10.0	\$ 2152	\$ 2264	\$ 2374	\$ 7099	\$ 7744
48"D x 144"W	ATLADM-TMRACE □ 48144F	214	11.9	\$ 2443	\$ 2569	\$ 2695	\$ 8760	\$ 9556

Racetrack Tops Knife

36"D x 60"W	ATLADM-TMRACE □ 3660K	67	6.0	\$ 2063	\$ 2170	\$ 2276	\$ 3503	\$ 3821
36"D x 72"W	ATLADM-TMRACE □ 3672K	80	7.1	\$ 2181	\$ 2294	\$ 2406	\$ 3724	\$ 4062
36"D x 84"W	ATLADM-TMRACE □ 3684K	94	8.2	\$ 2411	\$ 2536	\$ 2660	\$ 4103	\$ 4476
36"D x 96"W	ATLADM-TMRACE □ 3696K	107	9.4	\$ 2584	\$ 2717	\$ 2850	\$ 4626	\$ 5046
36"D x 108"W	ATLADM-TMRACE □ 36108K	120	10.5	\$ 2907	\$ 3057	\$ 3207	\$ 5141	\$ 5608
36"D x 120"W	ATLADM-TMRACE □ 36120K	134	11.6	\$ 3451	\$ 3630	\$ 3807	\$ 5872	\$ 6406
36"D x 144"W	ATLADM-TMRACE □ 36144K	160	13.9	\$ 3711	\$ 3903	\$ 4094	\$ 6760	\$ 7374
42"D x 72"W	ATLADM-TMRACE □ 4272K	94	8.2	\$ 2606	\$ 2740	\$ 2875	\$ 5088	\$ 5550
42"D x 84"W	ATLADM-TMRACE □ 4284K	109	9.5	\$ 2751	\$ 2894	\$ 3035	\$ 5807	\$ 6335
42"D x 96"W	ATLADM-TMRACE □ 4296K	125	10.8	\$ 2782	\$ 2926	\$ 3069	\$ 6010	\$ 6556
42"D x 108"W	ATLADM-TMRACE □ 42108K	140	12.1	\$ 3182	\$ 3346	\$ 3510	\$ 7075	\$ 7718
42"D x 120"W	ATLADM-TMRACE □ 42120K	156	8.8	\$ 3802	\$ 3998	\$ 4194	\$ 7743	\$ 8447
42"D x 144"W	ATLADM-TMRACE □ 42144K	187	10.5	\$ 4093	\$ 4305	\$ 4515	\$ 9372	\$ 10224
48"D x 72"W	ATLADM-TMRACE □ 4872K	107	9.3	\$ 2824	\$ 2970	\$ 3115	\$ 5554	\$ 6059
48"D x 84"W	ATLADM-TMRACE □ 4884K	125	10.8	\$ 3066	\$ 3224	\$ 3383	\$ 6356	\$ 6934
48"D x 96"W	ATLADM-TMRACE □ 4896K	143	12.2	\$ 3103	\$ 3263	\$ 3423	\$ 6724	\$ 7335
48"D x 108"W	ATLADM-TMRACE □ 48108K	160	13.7	\$ 3398	\$ 3574	\$ 3749	\$ 7732	\$ 8435
48"D x 120"W	ATLADM-TMRACE □ 48120K	178	10.0	\$ 3912	\$ 4114	\$ 4315	\$ 8841	\$ 9645
48"D x 144"W	ATLADM-TMRACE □ 48144K	214	11.9	\$ 4203	\$ 4420	\$ 4636	\$ 10502	\$ 11457

Note: Tops 120" or greater are two pieces.

How to specify — Select the Model Number from above.	1st Option: FSC Certified Wood: X Standard - No FSC F FSC Certified	2nd Option: Laminate/Veneer: See page 357 for finishes.	3rd Option: Edge (Laminate): See page 357 for finishes.	3rd Option: Top Finish (Veneer): FF Full Fill +\$282 (up to 120"W) +\$450 (for 144"W) OP Open Pore Low Sheen	4th Option: Cutout: GN No Grommet C1E 1 Bezel Mount Power C1TM 1 Tech Module C2E 2 Bezel Mount Power C2TM 2 Tech Module Note: C2 options for tables 108"W and greater.
ATLADM - TMRACE					

Example: ATLADM-TMRACEL3660F.X.LDW1.DW.GN

- Base includes external stiffeners for tops.
- Base ships knocked down.
- 108", 120", and 144" models have 6 legs.
- Bases 96" W and greater are only available with glides.
- For use with tops on pages 372-375.

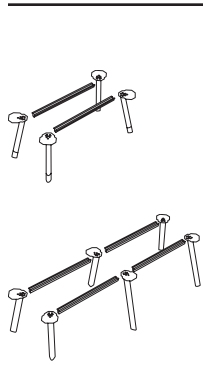

Description	Model	Ship Weight	Cubes	List Price	
				P1	P2
Meeting Table Bases — Continental Height					
For Tops 36"D x 60"W	ATLADM-BMTGM3660L	41	2.6	\$ 1650	\$ 1821
For Tops 36"D x 72"W	ATLADM-BMTGM3672L (shown)	48	3.3	\$ 1822	\$ 1993
For Tops 36"D x 84"W	ATLADM-BMTGM3684L	51	3.5	\$ 1862	\$ 2033
For Tops 36"D x 96"W	ATLADM-BMTGM3696L	54	3.7	\$ 2164	\$ 2360
For Tops 36"D x 108"W	ATLADM-BMTGM36108L	75	5.1	\$ 3179	\$ 3473
For Tops 36"D x 120"W	ATLADM-BMTGM36120L	77	5.3	\$ 3191	\$ 3485
For Tops 36"D x 144"W	ATLADM-BMTGM36144L	83	5.7	\$ 3271	\$ 3565
For Tops 42"D x 72"W	ATLADM-BMTGM4272L	49	3.3	\$ 1822	\$ 1993
For Tops 42"D x 84"W	ATLADM-BMTGM4284L	52	3.5	\$ 1862	\$ 2033
For Tops 42"D x 96"W	ATLADM-BMTGM4296L (shown)	54	3.7	\$ 2164	\$ 2360
For Tops 42"D x 108"W	ATLADM-BMTGM42108L	75	5.1	\$ 3179	\$ 3473
For Tops 42"D x 120"W	ATLADM-BMTGM42120L	77	5.3	\$ 3191	\$ 3485
For Tops 42"D x 144"W	ATLADM-BMTGM42144L	83	5.7	\$ 3271	\$ 3565
For Tops 48"D x 72"W	ATLADM-BMTGM4872L	42	3.3	\$ 2070	\$ 2266
For Tops 48"D x 84"W	ATLADM-BMTGM4884L	49	3.5	\$ 2110	\$ 2306
For Tops 48"D x 96"W	ATLADM-BMTGM4896L	52	3.7	\$ 2164	\$ 2360
For Tops 48"D x 108"W	ATLADM-BMTGM48108L	56	5.1	\$ 3179	\$ 3473
For Tops 48"D x 120"W	ATLADM-BMTGM48120L (shown)	77	5.3	\$ 3191	\$ 3485
For Tops 48"D x 144"W	ATLADM-BMTGM48144L	79	5.7	\$ 3271	\$ 3565

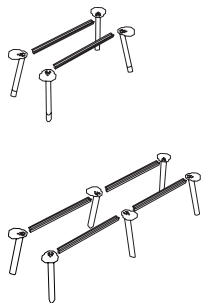

Meeting Table Bases — Seated Height					
For Tops 36"D x 60"W	ATLADM-BMTGM3660S	42	2.6	\$ 1700	\$ 1876
For Tops 36"D x 72"W	ATLADM-BMTGM3672S (shown)	49	3.3	\$ 1872	\$ 2048
For Tops 36"D x 84"W	ATLADM-BMTGM3684S	52	3.5	\$ 1912	\$ 2088
For Tops 36"D x 96"W	ATLADM-BMTGM3696S	56	3.7	\$ 2222	\$ 2424
For Tops 36"D x 108"W	ATLADM-BMTGM36108S	77	5.1	\$ 3266	\$ 3569
For Tops 36"D x 120"W	ATLADM-BMTGM36120S	79	5.3	\$ 3278	\$ 3581
For Tops 36"D x 144"W	ATLADM-BMTGM36144S	85	5.7	\$ 3358	\$ 3661
For Tops 42"D x 72"W	ATLADM-BMTGM4272S	49	3.3	\$ 1872	\$ 2048
For Tops 42"D x 84"W	ATLADM-BMTGM4284S	52	3.5	\$ 1912	\$ 2088
For Tops 42"D x 96"W	ATLADM-BMTGM4296S (shown)	56	3.7	\$ 2222	\$ 2424
For Tops 42"D x 108"W	ATLADM-BMTGM42108S	77	5.1	\$ 3266	\$ 3569
For Tops 42"D x 120"W	ATLADM-BMTGM42120S	79	5.3	\$ 3278	\$ 3581
For Tops 42"D x 144"W	ATLADM-BMTGM42144S	85	5.7	\$ 3358	\$ 3661
For Tops 48"D x 72"W	ATLADM-BMTGM4872S	51	3.3	\$ 2128	\$ 2330
For Tops 48"D x 84"W	ATLADM-BMTGM4884S	54	3.5	\$ 2168	\$ 2370
For Tops 48"D x 96"W	ATLADM-BMTGM4896S	56	3.7	\$ 2222	\$ 2424
For Tops 48"D x 108"W	ATLADM-BMTGM48108S	77	5.1	\$ 3266	\$ 3569
For Tops 48"D x 120"W	ATLADM-BMTGM48120S (shown)	79	5.3	\$ 3278	\$ 3581
For Tops 48"D x 144"W	ATLADM-BMTGM48144S	85	5.7	\$ 3358	\$ 3661

<p>How to specify — Select the Model Number from above.</p>	<p>1st Option: Paint Color: P1 P2 P3 See page 357 for finishes.</p>	<p>2nd Option: Caster/Glide: CSB Casters Black CSS Casters Silver GLD Glides WHB Wheelbarrow Black (2 Glides + 2 Casters Black) WHS Wheelbarrow Silver (2 Glides + 2 Casters Silver)</p>
<p>ATLADM - BMTGM . . </p>		

Example: ATLADM-BMTGM3660L.P1.GLD

- Base includes external stiffeners for tops.
- Base ships knocked down.
- 108", 120", and 144" models have 6 legs.

- Footrest is standard on counter and bar height tables at 11" off floor.

- Bases 96"W and greater are only available with glides.
- For use with tops on pages 372-375.

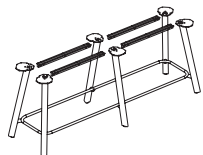
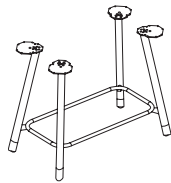
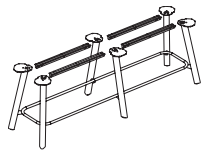
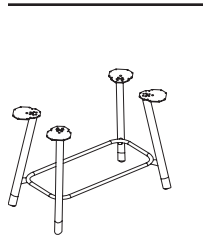

Description	Model	Ship Weight	Cubes	List Price	
				P1	P2
Meeting Table Bases — Counter Height					
For Tops 36"D x 60"W	ATLADM-BMTGM3660C	70	6.2	\$ 2700	\$ 2980
For Tops 36"D x 72"W	ATLADM-BMTGM3672C	79	7.0	\$ 2922	\$ 3207
For Tops 36"D x 84"W	ATLADM-BMTGM3684C	84	7.4	\$ 3062	\$ 3357
For Tops 36"D x 96"W	ATLADM-BMTGM3696C	91	7.7	\$ 3508	\$ 3842
For Tops 36"D x 108"W	ATLADM-BMTGM36108C	119	10.4	\$ 4895	\$ 5365
For Tops 36"D x 120"W	ATLADM-BMTGM36120C	123	10.7	\$ 5007	\$ 5487
For Tops 36"D x 144"W	ATLADM-BMTGM36144C	133	11.2	\$ 5187	\$ 5678
For Tops 42"D x 72"W	ATLADM-BMTGM4272C	79	7.0	\$ 2972	\$ 3262
For Tops 42"D x 84"W	ATLADM-BMTGM4284C	84	7.4	\$ 3112	\$ 3412
For Tops 42"D x 96"W	ATLADM-BMTGM4296C (shown)	91	7.7	\$ 3558	\$ 3897
For Tops 42"D x 108"W	ATLADM-BMTGM42108C	120	10.4	\$ 4945	\$ 5420
For Tops 42"D x 120"W	ATLADM-BMTGM42120C	124	10.7	\$ 5057	\$ 5543
For Tops 42"D x 144"W	ATLADM-BMTGM42144C	134	11.2	\$ 5237	\$ 5733
For Tops 48"D x 72"W	ATLADM-BMTGM4872C	83	7.0	\$ 3314	\$ 3638
For Tops 48"D x 84"W	ATLADM-BMTGM4884C	88	7.0	\$ 3454	\$ 3788
For Tops 48"D x 96"W	ATLADM-BMTGM4896C	92	7.4	\$ 3608	\$ 3953
For Tops 48"D x 108"W	ATLADM-BMTGM48108C	119	7.7	\$ 4995	\$ 5475
For Tops 48"D x 120"W	ATLADM-BMTGM48120C (shown)	123	5.3	\$ 5107	\$ 5598
For Tops 48"D x 144"W	ATLADM-BMTGM48144C	134	5.7	\$ 5287	\$ 5788

Meeting Table Bases — Bar Height					
For Tops 36"D x 60"W	ATLADM-BMTGM3660B	74	6.2	\$ 2800	\$ 3090
For Tops 36"D x 72"W	ATLADM-BMTGM3672B (shown)	83	7.0	\$ 3022	\$ 3317
For Tops 36"D x 84"W	ATLADM-BMTGM3684B	88	7.4	\$ 3162	\$ 3467
For Tops 36"D x 96"W	ATLADM-BMTGM3696B	96	7.7	\$ 3624	\$ 3971
For Tops 36"D x 108"W	ATLADM-BMTGM36108B	127	10.4	\$ 5069	\$ 5558
For Tops 36"D x 120"W	ATLADM-BMTGM36120B	131	10.7	\$ 5181	\$ 5680
For Tops 36"D x 144"W	ATLADM-BMTGM36144B	141	11.2	\$ 5361	\$ 5870
For Tops 42"D x 72"W	ATLADM-BMTGM4272B	83	6.7	\$ 3072	\$ 3372
For Tops 42"D x 84"W	ATLADM-BMTGM4284B	88	6.9	\$ 3212	\$ 3523
For Tops 42"D x 96"W	ATLADM-BMTGM4296B (shown)	96	7.1	\$ 3674	\$ 4026
For Tops 42"D x 108"W	ATLADM-BMTGM42108B	127	10.1	\$ 5119	\$ 5613
For Tops 42"D x 120"W	ATLADM-BMTGM42120B	131	10.3	\$ 5231	\$ 5735
For Tops 42"D x 144"W	ATLADM-BMTGM42144B	141	10.7	\$ 5411	\$ 5925
For Tops 48"D x 72"W	ATLADM-BMTGM4872B	88	6.7	\$ 3430	\$ 3766
For Tops 48"D x 84"W	ATLADM-BMTGM4884B	93	6.9	\$ 3570	\$ 3917
For Tops 48"D x 96"W	ATLADM-BMTGM4896B	97	7.1	\$ 3724	\$ 4081
For Tops 48"D x 108"W	ATLADM-BMTGM48108B	127	10.1	\$ 5169	\$ 5668
For Tops 48"D x 120"W	ATLADM-BMTGM48120B (shown)	131	10.3	\$ 5281	\$ 5790
For Tops 48"D x 144"W	ATLADM-BMTGM48144B	142	10.7	\$ 5461	\$ 5981

<p>How to specify — Select the Model Number from above.</p>	<p>1st Option: Paint Color: P1 P2 P3 See page 357 for finishes.</p>	<p>2nd Option: Caster/Glide: CSB Casters Black CSS Casters Silver GLD Glides WHB Wheelbarrow Black (2 Glides + 2 Casters Black) WHS Wheelbarrow Silver (2 Glides + 2 Casters Silver)</p>
<p>ATLADM - BMTGM . . </p>		

Example: ATLADM-BMTGM3660C.P1.GLD

- Order base separately.
- Option for cutout only, order power units separately.
- Reference page 361 for cutout locations.

- Available in veneer or laminate tops, flat or knife edge.
- Edgeband color option specified separately for laminate.

- Tops ship with pilot holes for locating base.
- For use with bases on page 380.
- Laminate tops are 1 piece. Veneer tops 54" and greater are 2 piece.

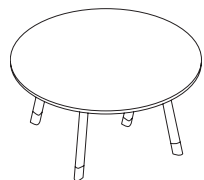
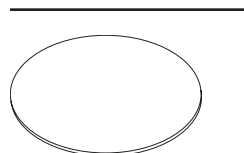

Example of Built-up Table

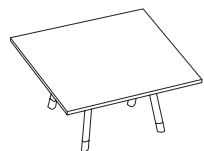
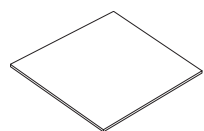

Example of Built-up Table

Description	Model Number add "L" for Laminate or "V" for Veneer	Ship Weight	Cubes	Laminate List Price			Veneer List Price	
				L1	L2	L3	V2	V3
Round Tops — Flat								
36" Diameter	ATLADM-TMRND □ 36F	40	3.7	\$ 612	\$ 644	\$ 675	\$ 2561	\$ 2794
42" Diameter	ATLADM-TMRND □ 42F	55	4.9	\$ 723	\$ 761	\$ 798	\$ 2781	\$ 3034
48" Diameter	ATLADM-TMRND □ 48F	71	6.3	\$ 880	\$ 926	\$ 971	\$ 3637	\$ 3968
54" Diameter	ATLADM-TMRND □ 54F	90	7.9	\$ 1273	\$ 1339	\$ 1404	\$ 4446	\$ 4850
60" Diameter	ATLADM-TMRND □ 60F	111	9.6	\$ 1466	\$ 1542	\$ 1618	\$ 5409	\$ 5901
Round Tops — Knife								
36" Diameter	ATLADM-TMRND □ 36K	40	3.7	\$ 1162	\$ 1222	\$ 1282	\$ 3106	\$ 3388
42" Diameter	ATLADM-TMRND □ 42K	55	4.9	\$ 1273	\$ 1339	\$ 1404	\$ 3326	\$ 3628
48" Diameter	ATLADM-TMRND □ 48K	71	6.3	\$ 1430	\$ 1505	\$ 1578	\$ 4182	\$ 4562
54" Diameter	ATLADM-TMRND □ 54K	90	7.9	\$ 1823	\$ 1917	\$ 2011	\$ 4990	\$ 5444
60" Diameter	ATLADM-TMRND □ 60K	111	9.6	\$ 2016	\$ 2121	\$ 2225	\$ 5954	\$ 6495
Square Tops — Flat								
36" D x 36" W	ATLADM-TMSQR □ 36F	40	3.7	\$ 551	\$ 580	\$ 608	\$ 2305	\$ 2514
42" D x 42" W	ATLADM-TMSQR □ 42F	55	4.9	\$ 651	\$ 685	\$ 718	\$ 2503	\$ 2730
48" D x 48" W	ATLADM-TMSQR □ 48F	71	6.3	\$ 792	\$ 834	\$ 874	\$ 3274	\$ 3572
54" D x 54" W	ATLADM-TMSQR □ 54F	90	7.9	\$ 1146	\$ 1205	\$ 1265	\$ 4000	\$ 4364
60" D x 60" W	ATLADM-TMSQR □ 60F	111	9.6	\$ 1319	\$ 1387	\$ 1455	\$ 4869	\$ 5312
Square Tops — Knife								
36" D x 36" W	ATLADM-TMSQR □ 36K	40	3.7	\$ 1046	\$ 1100	\$ 1155	\$ 2794	\$ 3048
42" D x 42" W	ATLADM-TMSQR □ 42K	55	4.9	\$ 1146	\$ 1205	\$ 1265	\$ 2992	\$ 3264
48" D x 48" W	ATLADM-TMSQR □ 48K	71	6.3	\$ 1287	\$ 1353	\$ 1420	\$ 3764	\$ 4106
54" D x 54" W	ATLADM-TMSQR □ 54K	90	7.9	\$ 1641	\$ 1726	\$ 1810	\$ 4491	\$ 4899
60" D x 60" W	ATLADM-TMSQR □ 60K	111	9.6	\$ 1814	\$ 1908	\$ 2001	\$ 5359	\$ 5846

Note: Laminate tops are 1 piece. Veneer tops 54" and greater are 2 piece.

<p>How to specify — Select the Model Number from above.</p> <p>ATLADM - TM .</p>	<p>1st Option: FSC Certified Wood: X Standard - No FSC F FSC Certified</p>	<p>2nd Option: Laminate/Veneer: See page 357 for finishes.</p>	<p>3rd Option: Edge (Laminate): See page 357 for finishes.</p>	<p>3rd Option: Top Finish (Veneer): FF Full Fill +\$282 OP Open Pore Low Sheen</p>	<p>4th Option: Cutout: GN No Grommet C1E 1 Bezel Mount Power C1TM 1 Tech Module</p>
	<p>Example: ATLADM-TMRNDL36FX.LDW1.DW.GN</p>				

Example: ATLADM-TMRNDL36FX.LDW1.DW.GN

- Order base separately.
- Option for cutout only, order power units separately.
- Reference page 361 for cutout locations.

- Available in veneer or laminate tops, flat or knife edge.
- Edgeband color option specified separately for laminate.
- Tops ship with pilot holes for locating base.

- For use with bases on page 380.
- Laminate tops are 1 piece. Veneer tops 54" and greater are 2 piece — adjoining seams are not edgebanded.

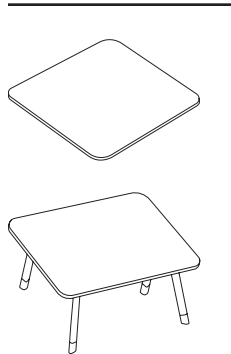

Example of Built-up Table

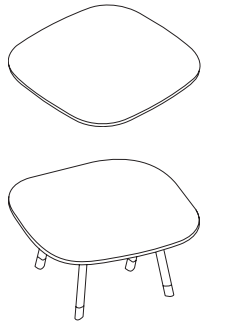

Example of Built-up Table

Description	Model Number add "L" for Laminate or "V" for Veneer	Ship Weight	Cubes	Laminate List Price			Veneer List Price	
				L1	L2	L3	V2	V3
Rounded Square Tops — Flat								
36" Diameter	ATLADM-TMRSQR □ 36F	40	3.7	\$ 612	\$ 644	\$ 675	\$ 2561	\$ 2794
42" Diameter	ATLADM-TMRSQR □ 42F	55	4.9	\$ 723	\$ 761	\$ 798	\$ 2781	\$ 3034
48" Diameter	ATLADM-TMRSQR □ 48F	71	6.3	\$ 880	\$ 926	\$ 971	\$ 3637	\$ 3968
54" Diameter	ATLADM-TMRSQR □ 54F	90	7.9	\$ 1273	\$ 1339	\$ 1404	\$ 4446	\$ 4850
60" Diameter	ATLADM-TMRSQR □ 60F	111	9.6	\$ 1466	\$ 1542	\$ 1618	\$ 5409	\$ 5901
Rounded Square Tops — Knife								
36" Diameter	ATLADM-TMRSQR □ 36K	40	3.7	\$ 1162	\$ 1222	\$ 1282	\$ 3106	\$ 3388
42" Diameter	ATLADM-TMRSQR □ 42K	55	4.9	\$ 1273	\$ 1339	\$ 1404	\$ 3326	\$ 3628
48" Diameter	ATLADM-TMRSQR □ 48K	71	6.3	\$ 1430	\$ 1505	\$ 1578	\$ 4182	\$ 4562
54" Diameter	ATLADM-TMRSQR □ 54K	90	7.9	\$ 1823	\$ 1917	\$ 2011	\$ 4990	\$ 5444
60" Diameter	ATLADM-TMRSQR □ 60K	111	9.6	\$ 2016	\$ 2121	\$ 2225	\$ 5954	\$ 6495
Soft Square Tops — Flat								
36" Diameter	ATLADM-TMSSQR □ 36F	40	3.7	\$ 612	\$ 644	\$ 675	\$ 2561	\$ 2794
42" Diameter	ATLADM-TMSSQR □ 42F	55	4.9	\$ 723	\$ 761	\$ 798	\$ 2781	\$ 3034
48" Diameter	ATLADM-TMSSQR □ 48F	71	6.3	\$ 880	\$ 926	\$ 971	\$ 3637	\$ 3968
54" Diameter	ATLADM-TMSSQR □ 54F	90	7.9	\$ 1273	\$ 1339	\$ 1404	\$ 4446	\$ 4850
60" Diameter	ATLADM-TMSSQR □ 60F	111	9.6	\$ 1466	\$ 1542	\$ 1618	\$ 5409	\$ 5901
Soft Square Tops — Knife								
36" Diameter	ATLADM-TMSSQR □ 36K	40	3.7	\$ 1162	\$ 1222	\$ 1282	\$ 3106	\$ 3388
42" Diameter	ATLADM-TMSSQR □ 42K	55	4.9	\$ 1273	\$ 1339	\$ 1404	\$ 3326	\$ 3628
48" Diameter	ATLADM-TMSSQR □ 48K	71	6.3	\$ 1430	\$ 1505	\$ 1578	\$ 4182	\$ 4562
54" Diameter	ATLADM-TMSSQR □ 54K	90	7.9	\$ 1823	\$ 1917	\$ 2011	\$ 4990	\$ 5444
60" Diameter	ATLADM-TMSSQR □ 60K	111	9.6	\$ 2016	\$ 2121	\$ 2225	\$ 5954	\$ 6495

Note: Laminate tops are 1 piece. Veneer tops 54" and greater are 2 piece.

<p>How to specify — Select the Model Number from above.</p> <p>ATLADM - TM .</p>	<p>1st Option: FSC Certified Wood:</p> <p>X Standard - No FSC</p> <p>F FSC Certified</p> <p> .</p>	<p>2nd Option: Laminate/Veneer:</p> <p>See page 357 for finishes.</p> <p> .</p>	<p>3rd Option: Edge (Laminate):</p> <p>See page 357 for finishes.</p> <p> .</p>	<p>3rd Option: Top Finish (Veneer):</p> <p>FF Full Fill +\$282</p> <p>OP Open Pore Low Sheen</p> <p> .</p>	<p>4th Option: Cutout:</p> <p>GN No Grommet</p> <p>C1E 1 Bezel Mount Power</p> <p>C1TM 1 Tech Module</p> <p> .</p>
---	--	---	---	--	--

Example: ATLADM-TMRSQR36F.X.LDW1.DW.GN

- Base ships knocked down.
- Footrest is standard on counter and bar height tables at 11" off floor. Shelf models do not have a footrest.
- Shelf models have a laminate or veneer shelf that is 14" below worksurface.
- For use with tops on pages 378-379.

Description	Model	Ship Weight	Cubes	List Price	
				P1	P2
Table Base Legs — Qty 4					
Continental Height	ATLADM-BMTGM4L (shown)	41	2.6	\$ 1650	\$ 1821
Standard Height	ATLADM-BMTGM4S	42	2.6	\$ 1700	\$ 1876
Small Meeting Table Bases — Counter Height					
For Tops 36"D x 36"W	ATLADM-BMTGM3636C	64	7.3	\$ 2550	\$ 2814
For Tops 42"D x 42"W	ATLADM-BMTGM4242C	65	7.6	\$ 2650	\$ 2924
For Tops 48"D x 48"W	ATLADM-BMTGM4848C (shown)	66	7.8	\$ 2750	\$ 3035
For Tops 54"D x 54"W	ATLADM-BMTGM5454C	67	8.1	\$ 2810	\$ 3101
For Tops 60"D x 60"W	ATLADM-BMTGM6060C	69	8.3	\$ 2850	\$ 3145
Small Meeting Table Bases — Bar Height					
For Tops 36"D x 36"W	ATLADM-BMTGM3636B	68	7.3	\$ 2650	\$ 2924
For Tops 42"D x 42"W	ATLADM-BMTGM4242B	69	7.6	\$ 2750	\$ 3035
For Tops 48"D x 48"W	ATLADM-BMTGM4848B (shown)	70	7.8	\$ 2850	\$ 3145
For Tops 54"D x 54"W	ATLADM-BMTGM5454B	72	8.1	\$ 2910	\$ 3211
For Tops 60"D x 60"W	ATLADM-BMTGM6060B	73	8.3	\$ 2950	\$ 3255

How to specify —
Select the Model Number from above.

1st Option:
Paint Color:
P1 P2 P3
See page 357 for finishes.

2nd Option:
Caster/Glide:
CSB Casters Black
CSS Casters Silver
GLD Glides
WHB Wheelbarrow Black (2 Glides + 2 Casters Black)
WHS Wheelbarrow Silver (2 Glides + 2 Casters Silver)

AT | LADM | - | BMTGM | | | | | . | | | | .

Example: ATLADM-BMTGM4L.P71.GLD

Description	Model Number add "L" for Laminate or "V" for Veneer	Ship Weight	Cubes	Laminate List Price			Veneer List Price	
				L1	L2	L3	V2	V3
Small Meeting Table Bases with High Shelf - Counter Height								
For Tops 48"D x 48"W	ATLADM-BMTGM □ 4848C	76	14.3	\$ 3674	\$ 3722	\$ 3769	\$ 4333	\$ 4727
For Tops 54"D x 54"W	ATLADM-BMTGM □ 5454C	81	16.1	\$ 3848	\$ 3902	\$ 3956	\$ 4562	\$ 4977
For Tops 60"D x 60"W	ATLADM-BMTGM □ 6060C	88	18.1	\$ 4003	\$ 4063	\$ 4122	\$ 4768	\$ 5201
Small Meeting Table Bases with High Shelf - Bar Height								
For Tops 48"D x 48"W	ATLADM-BMTGM □ 4848B	80	14.3	\$ 3774	\$ 3822	\$ 3869	\$ 4443	\$ 4847
For Tops 54"D x 54"W	ATLADM-BMTGM □ 5454B	85	16.1	\$ 3948	\$ 4002	\$ 4056	\$ 4672	\$ 5097
For Tops 60"D x 60"W	ATLADM-BMTGM □ 6060B	92	18.1	\$ 4103	\$ 4163	\$ 4222	\$ 4878	\$ 5321

How to specify —
Select the Model Number from above.

1st Option:
FSC Certified Wood:
X Standard - No FSC
F FSC Certified

2nd Option:
Laminate/Veneer:
See page 357 for finishes.

3rd Option:
Paint Color:
P1 P2 P3
See page 357 for finishes.

3rd Option:
Caster/Glide:
CSB Casters Black
CSS Casters Silver
GLD Glides
WHB Wheelbarrow Black (2 Glides + 2 Casters Black)
WHS Wheelbarrow Silver (2 Glides + 2 Casters Silver)

AT | LADM | - | BMTGM | | | | | . | | | | .

Example: ATLADM-BMTGML3636C.X.LDW1.DW.GLD

ADMIX

- Top and Base ordered separately.
- Option for cutout only, order power units separately.
- Reference page 361 for cutout locations.
- Available in veneer or laminate tops, flat or knife edge.
- Edgeband color option specified separately for laminate.
- Tops ship with pilot holes for locating base.
- Tops are 3 piece — adjoining seams are not edgebanded.
- Base ships knocked down.
- Bases have 9 legs total.
- **V-Media Top application will not have wood grain alignment.**

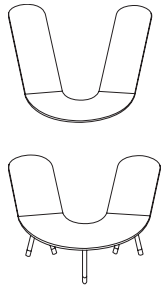

Example of Built-up Table

Description	Model Number add "L" for Laminate or "V" for Veneer	Ship Weight	Cubes	Laminate List Price			Veneer List Price		
				L1	L2	L3	V2	V3	
V Media Tops — Flat Edge									
15° — 4-Person	ATLADM-TVM15 □ 4PF	45	6.5	\$ 3638	\$ 3826	\$ 4013	\$ 6371	\$ 6950	
15° — 6-Person	ATLADM-TVM15 □ 6PF	62	8.9	\$ 4002	\$ 4208	\$ 4414	\$ 7007	\$ 7644	
15° — 8-Person	ATLADM-TVM15 □ 8PF	80	11.4	\$ 4402	\$ 4629	\$ 4856	\$ 7708	\$ 8409	
V Media Tops — Knife Edge									
15° — 4-Person	ATLADM-TVM15 □ 4PK	45	6.5	\$ 5238	\$ 5508	\$ 5778	\$ 7955	\$ 8678	
15° — 6-Person	ATLADM-TVM15 □ 6PK	62	8.9	\$ 5602	\$ 5891	\$ 6179	\$ 8591	\$ 9372	
15° — 8-Person	ATLADM-TVM15 □ 8PK	80	11.4	\$ 6002	\$ 6311	\$ 6620	\$ 9292	\$ 10137	
30° — 4-Person	ATLADM-TVM30 □ 4PF	45	6.5	\$ 3638	\$ 3826	\$ 4013	\$ 6371	\$ 6950	
30° — 6-Person	ATLADM-TVM30 □ 6PF	62	8.9	\$ 4002	\$ 4208	\$ 4414	\$ 7007	\$ 7644	
30° — 8-Person	ATLADM-TVM30 □ 8PF	80	11.4	\$ 4402	\$ 4629	\$ 4856	\$ 7708	\$ 8409	
55° — 4-Person	ATLADM-TVM55 □ 4PF	45	6.5	\$ 3638	\$ 3826	\$ 4013	\$ 6371	\$ 6950	
55° — 6-Person	ATLADM-TVM55 □ 6PF	62	8.9	\$ 4002	\$ 4208	\$ 4414	\$ 7007	\$ 7644	
55° — 8-Person	ATLADM-TVM55 □ 8PF	80	11.4	\$ 4402	\$ 4629	\$ 4856	\$ 7708	\$ 8409	

V Media Tops — Knife Edge

15° — 4-Person	ATLADM-TVM15 □ 4PK	45	6.5	\$ 5238	\$ 5508	\$ 5778	\$ 7955	\$ 8678
15° — 6-Person	ATLADM-TVM15 □ 6PK	62	8.9	\$ 5602	\$ 5891	\$ 6179	\$ 8591	\$ 9372
15° — 8-Person	ATLADM-TVM15 □ 8PK	80	11.4	\$ 6002	\$ 6311	\$ 6620	\$ 9292	\$ 10137
30° — 4-Person	ATLADM-TVM30 □ 4PK	45	6.5	\$ 5238	\$ 5508	\$ 5778	\$ 7955	\$ 8678
30° — 6-Person	ATLADM-TVM30 □ 6PK	62	8.9	\$ 5602	\$ 5891	\$ 6179	\$ 8591	\$ 9372
30° — 8-Person	ATLADM-TVM30 □ 8PK	80	11.4	\$ 6002	\$ 6311	\$ 6620	\$ 9292	\$ 10137
55° — 4-Person	ATLADM-TVM55 □ 4PK	45	6.5	\$ 5238	\$ 5508	\$ 5778	\$ 7955	\$ 8678
55° — 6-Person	ATLADM-TVM55 □ 6PK	62	8.9	\$ 5602	\$ 5891	\$ 6179	\$ 8591	\$ 9372
55° — 8-Person	ATLADM-TVM55 □ 8PK	80	11.4	\$ 6002	\$ 6311	\$ 6620	\$ 9292	\$ 10137

Note: All V-Media tops 3 pieces.

<p>How to specify — Select the Model Number from above.</p> <p>ATLADM -</p> <p>TVM .</p>	<p>1st Option: FSC Certified Wood:</p> <p>X Standard - No FSC</p> <p>F FSC Certified</p>	<p>2nd Option: Laminate/Veneer:</p> <p>See page 357 for finishes.</p>	<p>3rd Option: Edge (Laminate):</p> <p>See page 357 for finishes.</p>	<p>3rd Option: Top Finish (Veneer):</p> <p>FF Full Fill +\$282</p> <p>OP Open Pore Low Sheen</p>	<p>4th Option: Cutout:</p> <p>GN No Grommet</p> <p>C1E 1 Bezel Mount Power</p> <p>Note: 1 Bezel Mount Power included on each section of top = 3 cutouts total.</p>
	<p><i>Example:</i> ATLADM-TVM15L4PF.X.LDW1.DW.GN</p>				

Description	Model	Ship Weight	Cubes	List Price	
				P1	P2
V Media Bases — Standard Height					
4-Person	ATLADM-BVM4PSM5S (shown)	96	6.4	\$ 3825	\$ 4220
6-Person	ATLADM-BVM6PSM5S	108	7.6	\$ 4091	\$ 4486
8-Person	ATLADM-BVM8PSM5S	125	9.2	\$ 4465	\$ 4860

<p>How to specify — Select the Model Number from above.</p> <p>ATLADM - BVM .</p>	<p>1st Option: Paint Color:</p> <p>P1 P2 P3</p> <p>See page 357 for finishes.</p>	<p>2nd Option: Glide:</p> <p>GLD Glides</p>
	<p><i>Example:</i> ATLADM-BVM4PSM5S.P71.GLD</p>	

- Top and Base ordered separately.
- Option for cutout only, order power units separately.
- Reference page 361 for cutout locations.
- Available in veneer or laminate tops, flat or knife edge.
- Edgeband color option specified separately for laminate.
- Tops ship with pilot holes for locating base.
- Tops are 2 piece — adjoining seams are not edgebanded.
- Base ships knocked down.
- Bases have 8 legs total.
- Full Round Top application will not have wood grain alignment.

Description	Model Number add "L" for Laminate or "V" for Veneer	Ship Weight	Cubes	Laminate List Price			Veneer List Price	
				L1	L2	L3	V2	V3
Full Round Tops — Open Center								
24"D x 96" Diameter — Flat Edge	ATLADM-TFRND □ 96F	143	6.5	\$ 2705	\$ 2845	\$ 2985	\$ 8362	\$ 9122
24"D x 96" Diameter — Knife Edge	ATLADM-TFRND □ 96K	143	6.5	\$ 3455	\$ 3634	\$ 3812	\$ 9104	\$ 9932

Note: Full round tops come in 2 pieces.

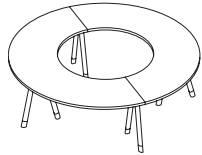

Example of Built-up Table

How to specify — Select the Model Number from above.	1st Option: FSC Certified Wood: X Standard - No FSC F FSC Certified	2nd Option: Laminate/Veneer: See page 357 for finishes.	3rd Option: Edge (Laminate): See page 357 for finishes.	3rd Option: Top Finish (Veneer): FF Full Fill +\$282 OP Open Pore Low Sheen	4th Option: Cutout: GN No Grommet C1E 1 Bezel Mount Power Note: 2 Bezel Mount Power included on each section of top = 4 cutouts total.
ATLADM - TFRND					

Example: ATLADM-TFRNDL96F.X.LDW1.DW.GN

Description	Model	Ship Weight	Cubes	List Price	
				P1	P2
Full Round Table Bases — Standard Height					
For 96" Diameter Tops	ATLADM-BFRNDM96S	101	6.8	\$ 3796	\$ 4147

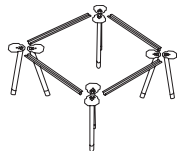

How to specify — Select the Model Number from above.	1st Option: Paint Color: P1 P2 P3 See page 357 for finishes.	2nd Option: Glide: GLD Glides
ATLADM - BFRNDM96S		GLD

Example: ATLADM-BFRNDM96S.P71.GLD

- Top and Base ordered separately.
- Option for cutout only, order power units separately.
- Reference page 361 for cutout locations.
- Available in veneer or laminate tops, flat or knife edge.
- Edgeband color option specified separately for laminate.
- Tops ship with pilot holes for locating base.
- Rounded Media — Laminate and veneer tops are 1 piece.
- Bulb Media — Laminate tops are 1 piece. Veneer tops 54" and greater are 2 piece — adjoining seams are not edgebanded.
- For use with bases on page 384 and media walls on page 385.

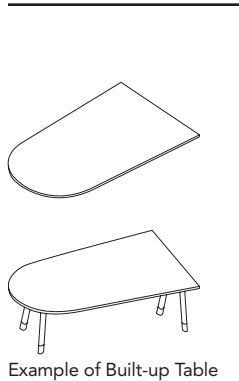

Description	Model Number add "L" for Laminate or "V" for Veneer	Ship Weight	Cubes	Laminate List Price			Veneer List Price	
				L1	L2	L3	V2	V3
Rounded Media Tops — Flat Edge								
48/36"D x 48"W	ATLADM-TRMED □ 4848F	71	6.3	\$ 1159	\$ 1219	\$ 1279	\$ 3637	\$ 3968
48/36"D x 60"W	ATLADM-TRMED □ 4860F	89	7.8	\$ 1220	\$ 1283	\$ 1346	\$ 3830	\$ 4178
48/36"D x 72"W	ATLADM-TRMED □ 4872F	107	9.3	\$ 1284	\$ 1350	\$ 1416	\$ 4030	\$ 4396
48/36"D x 84"W	ATLADM-TRMED □ 4884F	125	10.8	\$ 1526	\$ 1605	\$ 1684	\$ 4832	\$ 5271
48/36"D x 96"W	ATLADM-TRMED □ 4896F	143	12.2	\$ 1563	\$ 1644	\$ 1724	\$ 5199	\$ 5672
Rounded Media Tops — Knife Edge								
48/36"D x 48"W	ATLADM-TRMED □ 4848K	71	6.3	\$ 2559	\$ 2691	\$ 2823	\$ 5023	\$ 5480
48/36"D x 60"W	ATLADM-TRMED □ 4860K	89	7.8	\$ 2620	\$ 2755	\$ 2890	\$ 5216	\$ 5690
48/36"D x 72"W	ATLADM-TRMED □ 4872K	107	9.3	\$ 2684	\$ 2823	\$ 2961	\$ 5416	\$ 5908
48/36"D x 84"W	ATLADM-TRMED □ 4884K	125	10.8	\$ 2926	\$ 3077	\$ 3228	\$ 6218	\$ 6783
48/36"D x 96"W	ATLADM-TRMED □ 4896K	143	12.2	\$ 2963	\$ 3116	\$ 3268	\$ 6585	\$ 7184

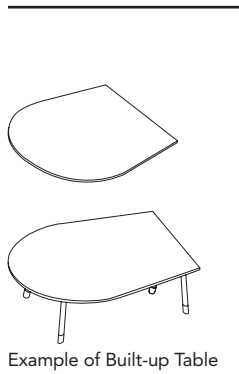

Description	Model Number add "L" for Laminate or "V" for Veneer	Ship Weight	Lam Cubes	Ven Cubes	Laminate List Price			Veneer List Price	
					L1	L2	L3	V2	V3
Bulb Media Tops — Flat Edge									
48/36"D x 48"W	ATLADM-TBMED □ 4848F	89	7.8	5.2	\$ 1159	\$ 1219	\$ 1279	\$ 3637	\$ 3968
48/36"D x 60"W	ATLADM-TBMED □ 4860F	111	9.6	6.5	\$ 1220	\$ 1283	\$ 1346	\$ 3830	\$ 4178
48/36"D x 72"W	ATLADM-TBMED □ 4872F	134	11.5	7.7	\$ 1284	\$ 1350	\$ 1416	\$ 4030	\$ 4396
48/36"D x 84"W	ATLADM-TBMED □ 4884F	156	13.3	8.9	\$ 1526	\$ 1605	\$ 1684	\$ 4832	\$ 5271
48/36"D x 96"W	ATLADM-TBMED □ 4896F	178	15.1	10.2	\$ 1563	\$ 1644	\$ 1724	\$ 5199	\$ 5672
Bulb Media Tops — Knife Edge									
48/36"D x 48"W	ATLADM-TBMED □ 4848K	71	6.3	5.2	\$ 2559	\$ 2691	\$ 2823	\$ 5023	\$ 5480
48/36"D x 60"W	ATLADM-TBMED □ 4860K	89	7.8	6.5	\$ 2620	\$ 2755	\$ 2890	\$ 5216	\$ 5690
48/36"D x 72"W	ATLADM-TBMED □ 4872K	107	9.3	7.7	\$ 2684	\$ 2823	\$ 2961	\$ 5416	\$ 5908
48/36"D x 84"W	ATLADM-TBMED □ 4884K	125	10.8	8.9	\$ 2926	\$ 3077	\$ 3228	\$ 6218	\$ 6783
48/36"D x 96"W	ATLADM-TBMED □ 4896K	143	12.2	10.2	\$ 2963	\$ 3116	\$ 3268	\$ 6585	\$ 7184

Note: Laminate tops are 1 piece. Veneer tops 54" and greater are 2 piece.

<p>How to specify — Select the Model Number from above.</p> <p>ATLAD TBMED</p>	<p>1st Option: FSC Certified Wood: X Standard - No FSC F FSC Certified</p>	<p>2nd Option: Laminate/Veneer: See page 357 for finishes.</p>	<p>3rd Option: Edge (Laminate): See page 357 for finishes.</p>	<p>3rd Option: Top Finish (Veneer): FF Full Fill +\$282 OP Open Pore Low Sheen</p>	<p>4th Option: Cutout: GN No Grommet C1E 1 Bezel Mount Power C1TM 1 Tech Module</p>
---	---	---	---	---	--

Example: ATLADM-ACCWIREMGR18.eps-TRMEDL4848F.X.LDW1.DW.GN

- Must be attached to the wall. Not for freestanding applications. Z brackets included for wall mounting.
- Top and bottom are 2 piece and require field assembly. Fabric panel also ships unassembled.
- Center panel on lower cabinet is a hinged door for access to wires and outlets.
- A vertical cavity exists from the hinged door to the fabric panel cutout to manage wires. Wire cavity is 4.25"D x 15.0"W with a grommet pass through from top to bottom halves.
- Table attached models include an angle bracket to support end of table and a grommet cutout to manage cords from bottom of table top to inside of media wall.
- Floating media walls can be mounted at desired height in field.
- Fabric panel attaches to media wall with Z brackets. TV mount GATVMB can be attached directly to face of the fabric panel. A low profile non-articulating TV mount should be used.
- Fabric panel is 60"W x 40"H and intended for use with flat screen TV's 55" and smaller.
- Center cutout in fabric panel is 10"W x 10"H to manage wires into media wall.

Description	Model Number add "L" for Laminate or "V" for Veneer	Ship Weight	Cubes	Laminate List Price			Veneer List Price	
				L1	L2	L3	V2	V3
Fabric Media Wall — No Table								
For Cont'l Height	ATLADM-MNWALLF □ 60L (shown)	85	13.2	\$ 4778	\$ 4929	\$ 5080	\$ 6866	\$ 7490
For Standard Height	ATLADM-MNWALLF □ 60S	87	13.4	\$ 4853	\$ 5008	\$ 5162	\$ 6989	\$ 7624
For Counter Height	ATLADM-MNWALLF □ 60C	96	14.3	\$ 4928	\$ 5087	\$ 5246	\$ 7113	\$ 7760
For Bar Height	ATLADM-MNWALLF □ 60B	104	15.0	\$ 5007	\$ 5170	\$ 5332	\$ 7243	\$ 7901
Fabric Media Wall — Table Attached								
For Cont'l Height	ATLADM-MTWALLF □ 60L	93	13.6	\$ 4997	\$ 5148	\$ 5299	\$ 7106	\$ 7752
For Standard Height	ATLADM-MTWALLF □ 60S (shown)	96	13.8	\$ 5072	\$ 5227	\$ 5381	\$ 7230	\$ 7887
For Counter Height	ATLADM-MTWALLF □ 60C	105	14.6	\$ 5147	\$ 5306	\$ 5465	\$ 7354	\$ 8022
For Bar Height	ATLADM-MTWALLF □ 60B	113	15.3	\$ 5226	\$ 5389	\$ 5551	\$ 7484	\$ 8164
Note: Table attached models require table to be ordered separately.								
Fabric Media Wall — Floating								
No Table	ATLADM-MNWFLTF □ 6040	44	10.1	\$ 3353	\$ 3431	\$ 3508	\$ 4514	\$ 4924
Table Attached	ATLADM-MTWFLTF □ 6040 (shown)	52	10.4	\$ 3572	\$ 3650	\$ 3727	\$ 4755	\$ 5187
Note: Table attached models require table to be ordered separately.								

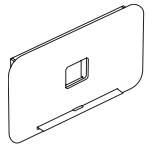
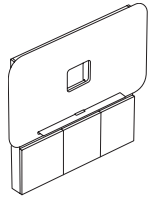
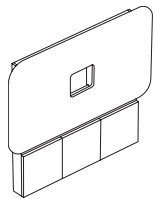

ADMIX

<p>How to specify — Select the Model Number from above.</p> <p>AT L ADM - M </p>	<p>1st Option: FSC Certified Wood: X Standard - No FSC F FSC Certified</p>	<p>2nd Option: Laminate/Veneer: See page 357 for finishes.</p>	<p>3rd Option: Fabric: See page 358 for fabrics.</p>
--	---	---	---

Example: ATLADM-MNWALLFL60L.X.LDW1.NBLE13

- Wall Mount Bracket is used to fasten one end of a table top to the wall. User to provide mounting hardware.
- Table Media Mount is used to mount a television to the end of a table top when not against a wall. Mounting hardware is provided for television sizes 32" to 50" with VESA Mounts of 100 x 100 to 200 x 200; for some televisions, additional hardware is required.

Description	Model	Ship Weight	Cubes	List Price	
				P1	P2
Table Wall Mount Bracket					
Wall Mount Bracket	AMPTWMB	4.0	0.4	\$ 157	N/A
Note: For applications with tables attached to drywall or building walls. Not required in media wall applications.					
TV Bracket Clamp Mount					
Table Media Mount	AMPTTMM	4.0	0.4	\$ 318	\$ 330
Note: For use with freestanding tables. Not for use in applications with media table attached to media walls.					
TV Wall Mount Bracket					
26½"W x 17½"H; -10° -0° Tilt	GATVMB			\$ 554	N/A
Includes mounting hardware and conforms to VESA-compliant displays. Supports up to 165 lbs.					
Note: Can be attached to Media Wall Fabric panel or directly to drywall/building walls.					

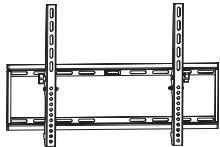
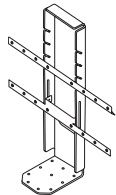
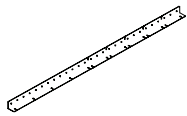

ADMIX

How to specify —

Select the Model Number from above.

--	--	--	--	--	--	--	--	--	--	--

Example: AMPTWMB

- Order base separately.
- Option for cutout only, order power units separately.
- Reference page 361 for cutout locations.
- Available in veneer or laminate tops, flat or knife edge.
- Edgeband color option specified separately for laminate.
- Tops ship with pilot holes for locating base.
- For use with bases on page 388.

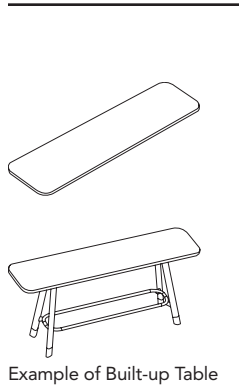

Description	Model Number add "L" for Laminate or "V" for Veneer	Ship Weight	Cubes	Laminate List Price			Veneer List Price	
				L1	L2	L3	V2	V3
Perch Rounded Rectangular Tops — Flat Edge								
20"D x 48"W	ATLADM-TPRREC □ 2048F	30	2.8	\$ 536	\$ 564	\$ 592	\$ 1274	\$ 1390
20"D x 60"W	ATLADM-TPRREC □ 2060F	37	3.5	\$ 553	\$ 582	\$ 610	\$ 1458	\$ 1590
20"D x 72"W	ATLADM-TPRREC □ 2072F	45	4.2	\$ 600	\$ 631	\$ 662	\$ 1732	\$ 1889
20"D x 84"W	ATLADM-TPRREC □ 2084F	52	4.8	\$ 704	\$ 741	\$ 777	\$ 1872	\$ 2042
20"D x 96"W	ATLADM-TPRREC □ 2096F	59	5.5	\$ 739	\$ 778	\$ 816	\$ 2341	\$ 2554

Perch Rounded Rectangular Tops — Knife Edge								
20"D x 48"W	ATLADM-TPRREC □ 2048K	30	2.8	\$ 1086	\$ 1142	\$ 1199	\$ 1819	\$ 1984
20"D x 60"W	ATLADM-TPRREC □ 2060K	37	3.5	\$ 1553	\$ 1634	\$ 1713	\$ 2448	\$ 2670
20"D x 72"W	ATLADM-TPRREC □ 2072K	45	4.2	\$ 1600	\$ 1683	\$ 1765	\$ 2722	\$ 2969
20"D x 84"W	ATLADM-TPRREC □ 2084K	52	4.8	\$ 1704	\$ 1792	\$ 1880	\$ 2862	\$ 3122
20"D x 96"W	ATLADM-TPRREC □ 2096K	59	5.5	\$ 1739	\$ 1829	\$ 1919	\$ 3331	\$ 3634

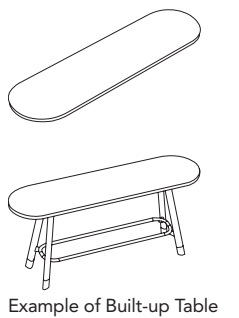

Perch Racetrack Tops — Flat Edge								
20"D x 48"W	ATLADM-TPRACE □ 2048F	30	2.8	\$ 536	\$ 564	\$ 592	\$ 1274	\$ 1390
20"D x 60"W	ATLADM-TPRACE □ 2060F	37	3.5	\$ 553	\$ 582	\$ 610	\$ 1458	\$ 1590
20"D x 72"W	ATLADM-TPRACE □ 2072F	45	4.2	\$ 600	\$ 631	\$ 662	\$ 1732	\$ 1889
20"D x 84"W	ATLADM-TPRACE □ 2084F	52	4.8	\$ 704	\$ 741	\$ 777	\$ 1872	\$ 2042
20"D x 96"W	ATLADM-TPRACE □ 2096F	59	5.5	\$ 739	\$ 778	\$ 816	\$ 2341	\$ 2554

Perch Racetrack Tops — Knife Edge								
20"D x 48"W	ATLADM-TPRACE □ 2048K	30	2.8	\$ 1086	\$ 1142	\$ 1199	\$ 1819	\$ 1984
20"D x 60"W	ATLADM-TPRACE □ 2060K	37	3.5	\$ 1553	\$ 1634	\$ 1713	\$ 2448	\$ 2670
20"D x 72"W	ATLADM-TPRACE □ 2072K	45	4.2	\$ 1600	\$ 1683	\$ 1765	\$ 2722	\$ 2969
20"D x 84"W	ATLADM-TPRACE □ 2084K	52	4.8	\$ 1704	\$ 1792	\$ 1880	\$ 2862	\$ 3122
20"D x 96"W	ATLADM-TPRACE □ 2096K	59	5.5	\$ 1739	\$ 1829	\$ 1919	\$ 3331	\$ 3634

<p>How to specify — Select the Model Number from above.</p> <p>ATLADM - TPR</p>	<p>1st Option: FSC Certified Wood: X Standard - No FSC F FSC Certified</p>	<p>2nd Option: Laminate/Veneer: See page 357 for finishes.</p>	<p>3rd Option: Edge (Laminate): See page 357 for finishes.</p>	<p>3rd Option: Top Finish (Veneer): FF Full Fill +\$282 OP Open Pore Low Sheen</p>	<p>4th Option: Cutout: GN No Grommet C1E 1 Bezel Mount Power</p>
--	---	---	---	---	---

Example: ATLADM-TPRRECL2048F.X.LDW1.DW.GN

- Base ships knocked down.
- Base includes external stiffeners for tops (if required).
- Footrest is standard on counter and bar height tables at 11" off floor.
- For use with tops on page 387.

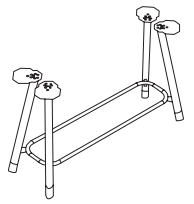
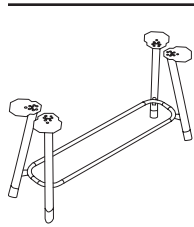

Description	Model	Ship Weight	Cubes	List Price	
				P1	P2
Perch Table Bases — Counter Height					
For Tops 20"D x 48"W	ATLADM-BPERM2048C	64	6.1	\$ 2550	\$ 2814
For Tops 20"D x 60"W	ATLADM-BPERM2060C	66	6.2	\$ 2600	\$ 2869
For Tops 20"D x 72"W	ATLADM-BPERM2072C (shown)	68	6.3	\$ 2650	\$ 2924
For Tops 20"D x 84"W	ATLADM-BPERM2084C	75	6.9	\$ 2856	\$ 3141
For Tops 20"D x 96"W	ATLADM-BPERM2096C	78	7.1	\$ 2983	\$ 3278

Perch Table Bases — Bar Height					
For Tops 20"D x 48"W	ATLADM-BPERM2048B	68	6.1	\$ 2650	\$ 2924
For Tops 20"D x 60"W	ATLADM-BPERM2060B	70	6.2	\$ 2700	\$ 2980
For Tops 20"D x 72"W	ATLADM-BPERM2072B (shown)	72	6.3	\$ 2750	\$ 3035
For Tops 20"D x 84"W	ATLADM-BPERM2084B	79	6.9	\$ 2956	\$ 3251
For Tops 20"D x 96"W	ATLADM-BPERM2096B	82	7.1	\$ 3083	\$ 3388

ADMIX

<p>How to specify — Select the Model Number from above.</p>	<p>1st Option: Paint Color: <input type="radio"/> P1 <input type="radio"/> P2 <input type="radio"/> P3 See page 357 for finishes.</p>	<p>2nd Option: Caster/Glide: CSB Casters Black CSS Casters Silver GLD Glides (only 96"W) WHB Wheelbarrow Black (2 Glides + 2 Casters Black) WHS Wheelbarrow Silver (2 Glides + 2 Casters Silver)</p>
<p>ATLADM - BPERM20 . .</p>		

Example: ATLADM-BPERM2048C.P71.GLD

- Top and Base ordered separately.
- Option for cutout only, order power units separately.
- Reference page 361 for cutout locations.
- Available in veneer or laminate tops, flat or knife edge.
- Edgeband color option specified separately for laminate.
- Tops ship with pilot holes for locating base.
- Base includes external stiffeners for tops (if required).
- Shelf is standard on counter and bar height tables at 11" off floor.

Description	Model Number add "L" for Laminate or "V" for Veneer	Ship Weight	Cubes	Laminate List Price			Veneer List Price		
				L1	L2	L3	V2	V3	
Console Rounded Rectangular Table Tops — Flat Edge									
20"D x 48"W	ATLADM-TCRREC □ 2048F	30	2.8	\$ 536	\$ 564	\$ 592	\$ 1274	\$ 1390	
20"D x 60"W	ATLADM-TCRREC □ 2060F	37	3.5	\$ 553	\$ 582	\$ 610	\$ 1458	\$ 1590	
20"D x 72"W	ATLADM-TCRREC □ 2072F	45	4.2	\$ 600	\$ 631	\$ 662	\$ 1732	\$ 1889	
20"D x 84"W	ATLADM-TCRREC □ 2084F	52	4.8	\$ 704	\$ 741	\$ 777	\$ 1872	\$ 2042	
20"D x 96"W	ATLADM-TCRREC □ 2096F	59	5.5	\$ 739	\$ 778	\$ 816	\$ 2341	\$ 2554	
Console Rounded Rectangular Table Tops — Knife Edge									
20"D x 48"W	ATLADM-TCRREC □ 2048K	30	2.8	\$ 1086	\$ 1142	\$ 1199	\$ 1819	\$ 1984	
20"D x 60"W	ATLADM-TCRREC □ 2060K	37	3.5	\$ 1553	\$ 1634	\$ 1713	\$ 2448	\$ 2670	
20"D x 72"W	ATLADM-TCRREC □ 2072K	45	4.2	\$ 1600	\$ 1683	\$ 1765	\$ 2722	\$ 2969	
20"D x 84"W	ATLADM-TCRREC □ 2084K	52	4.8	\$ 1704	\$ 1792	\$ 1880	\$ 2862	\$ 3122	
20"D x 96"W	ATLADM-TCRREC □ 2096K	59	5.5	\$ 1739	\$ 1829	\$ 1919	\$ 3331	\$ 3634	

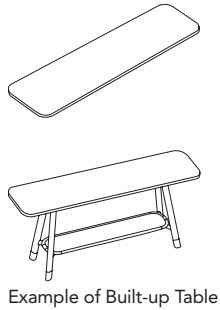

Example of Built-up Table

How to specify — Select the Model Number from above. ATLADM - TCR REC	1st Option: FSC Certified Wood: X Standard - No FSC F FSC Certified	2nd Option: Laminate/Veneer: See page 357 for finishes.	3rd Option: Edge (Laminate): See page 357 for finishes.	3rd Option: Top Finish (Veneer): FF Full Fill +\$282 OP Open Pore Low Sheen	4th Option: Cutout: GN No Grommet C1E 1 Bezel Mount Power

Example: ATLADM-TCRRECL2048F.X.LDW1.DW.GN

Description	Model Number add "L" for Laminate or "V" for Veneer	Ship Weight	Cubes	Laminate List Price			Veneer List Price		
				L1	L2	L3	V2	V3	
Console Table Base with Low Shelf — Counter Height									
For Tops 20"D x 48"W	ATLADM-BCONM □ 2048C	69	6.9	\$ 3118	\$ 3147	\$ 3177	\$ 3611	\$ 3939	
For Tops 20"D x 60"W	ATLADM-BCONM □ 2060C	73	7.3	\$ 3244	\$ 3277	\$ 3310	\$ 3771	\$ 4114	
For Tops 20"D x 72"W	ATLADM-BCONM □ 2072C (shown)	77	7.7	\$ 3355	\$ 3392	\$ 3429	\$ 3915	\$ 4271	
For Tops 20"D x 84"W	ATLADM-BCONM □ 2084C	86	8.6	\$ 3631	\$ 3672	\$ 3712	\$ 4245	\$ 4631	
For Tops 20"D x 96"W	ATLADM-BCONM □ 2096C	92	9.1	\$ 3836	\$ 3881	\$ 3924	\$ 4494	\$ 4902	
Console Table Base with Low Shelf — Bar Height									
For Tops 20"D x 48"W	ATLADM-BCONM □ 2048B	75	7.0	\$ 3218	\$ 3247	\$ 3277	\$ 3721	\$ 4059	
For Tops 20"D x 60"W	ATLADM-BCONM □ 2060B	80	7.4	\$ 3344	\$ 3377	\$ 3410	\$ 3881	\$ 4234	
For Tops 20"D x 72"W	ATLADM-BCONM □ 2072B (shown)	85	7.9	\$ 3455	\$ 3492	\$ 3529	\$ 4135	\$ 4511	
For Tops 20"D x 84"W	ATLADM-BCONM □ 2084B	95	8.8	\$ 3731	\$ 3772	\$ 3812	\$ 4355	\$ 4751	
For Tops 20"D x 96"W	ATLADM-BCONM □ 2096B	100	9.3	\$ 3936	\$ 3981	\$ 4024	\$ 4604	\$ 5022	

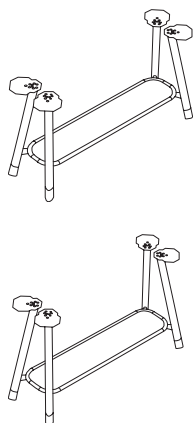

How to specify — Select the Model Number from above. ATLADM - BIC ONM	1st Option: FSC Certified Wood: X Standard - No FSC F FSC Certified	2nd Option: Laminate/Veneer: See page 357 for finishes.	3rd Option: Paint Color: P1 P2 P3 See page 357 for finishes.	4th Option: Caster/Glide: CSB Casters Black CSS Casters Silver GLD Glides (96" can only use Glides) WHB Wheelbarrow Black (2 Glides + 2 Casters Black) WHS Wheelbarrow Silver (2 Glides + 2 Casters Silver)

Example: ATLADM-BCONML2048C.X.LDW1.P71.GLD

- Top and Base ordered separately.
- Option for cutout only, order power units separately.
- Reference page 361 for cutout locations.
- Available in veneer or laminate tops, flat or knife edge.
- Edgeband color option specified separately for laminate.
- Tops ship with pilot holes for locating base.
- An upper and lower shelf is standard on counter and bar height tables. The low shelf is 11" off floor and the upper shelf is 14" below worksurface.

Description	Model Number add "L" for Laminate or "V" for Veneer	Ship Weight	Cubes	Laminate List Price			Veneer List Price	
				L1	L2	L3	V2	V3
Project Cart Tops — Flat Edge								
24"D x 36"W	ATLADM-TJRREC □ 2436F	27	2.6	\$ 506	\$ 532	\$ 559	\$ 1071	\$ 1168
24"D x 42"W	ATLADM-TJRREC □ 2442F	31	2.9	\$ 542	\$ 570	\$ 598	\$ 1219	\$ 1330
24"D x 48"W	ATLADM-TJRREC □ 2448F	36	3.3	\$ 561	\$ 590	\$ 619	\$ 1336	\$ 1457
Project Cart Tops — Knife Edge								
24"D x 36"W	ATLADM-TJRREC □ 2436K	27	2.6	\$ 1056	\$ 1111	\$ 1166	\$ 1615	\$ 1762
24"D x 42"W	ATLADM-TJRREC □ 2442K	31	2.9	\$ 1092	\$ 1149	\$ 1205	\$ 1764	\$ 1924
24"D x 48"W	ATLADM-TJRREC □ 2448K	36	3.3	\$ 1111	\$ 1169	\$ 1226	\$ 1880	\$ 2051

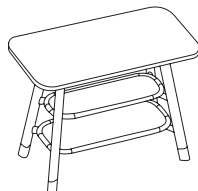
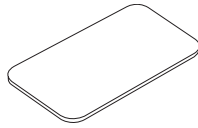

Example of Built-up Table

How to specify — Select the Model Number from above. ATLADM - TJR REC	1st Option: FSC Certified Wood: X Standard - No FSC F FSC Certified	2nd Option: Laminate/Veneer: See page 357 for finishes.	3rd Option: Edge (Laminate): See page 357 for finishes.	3rd Option: Top Finish (Veneer): FF Full Fill +\$282 OP Open Pore Low Sheen	4th Option: Cutout: GN No Grommet C1E 1 Bezel Mount Power

Example: ATLADM-TJRRECL2436F.X.LDW1.DW.GN

Description	Model Number add "L" for Laminate or "V" for Veneer	Ship Weight	Cubes	Laminate List Price			Veneer List Price	
				L1	L2	L3	V2	V3
Project Cart Base with 2 Shelves — Counter Height								
For Tops 24"D x 36"W	ATLADM-BPROJM □ 2436C	94	7.6	\$ 3689	\$ 3722	\$ 3755	\$ 4591	\$ 5008
For Tops 24"D x 42"W	ATLADM-BPROJM □ 2442C	98	7.9	\$ 3869	\$ 3907	\$ 3944	\$ 4855	\$ 5296
	(shown)							
For Tops 24"D x 48"W	ATLADM-BPROJM □ 2448C	103	8.2	\$ 4062	\$ 4105	\$ 4146	\$ 5143	\$ 5610
Project Cart Base with 2 Shelves — Bar Height								
For Tops 24"D x 36"W	ATLADM-BPROJM □ 2436B	100	7.8	\$ 3789	\$ 3822	\$ 3855	\$ 4701	\$ 5128
For Tops 24"D x 42"W	ATLADM-BPROJM □ 2442B	105	8.1	\$ 3969	\$ 4007	\$ 4044	\$ 4965	\$ 5416
	(shown)							
For Tops 24"D x 48"W	ATLADM-BPROJM □ 2448B	109	8.5	\$ 4162	\$ 4205	\$ 4246	\$ 5253	\$ 5730

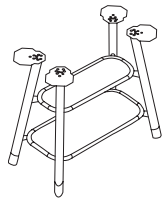
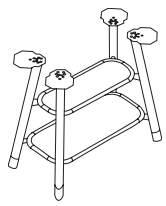

How to specify — Select the Model Number from above. ATLADM - BPROJM	1st Option: FSC Certified Wood: X Standard - No FSC F FSC Certified	2nd Option: Laminate/Veneer: See page 357 for finishes.	3rd Option: Paint Color: P1 P2 P3 See page 357 for finishes.	4th Option: Caster/Glide: CSB Casters Black CSS Casters Silver GLD Glides (96" can only use Glides) WHB Wheelbarrow Black (2 Glides + 2 Casters Black) WHS Wheelbarrow Silver (2 Glides + 2 Casters Silver)

Example: ATLADM-BPROJML2436C.X.LDW1.P71.GLD

ADMIX

- Top and Base ordered separately.
- Available in veneer or laminate tops, flat or knife edge.
- Edgeband color option specified separately for laminate.
- Tops ship with pilot holes for locating base.
- Base includes:
 - Qty 3 — undermount power units daisy chained together with 20ft braided standard plug cord.
 - Qty 1 — wire hook for braided cord.
 - Qty 1 — low metal shelf 11" off the floor.
- Specified paint color on base applies to table legs, metal shelf, and wire hook.

Description	Model Number add "L" for Laminate or "V" for Veneer	Ship Weight	Cubes	Laminate List Price			Veneer List Price	
				L1	L2	L3	V2	V3
Satellite Table — 24" Diameter								
Flat Edge	ATLADM-TSSQR □ 24F	18	0.8	\$ 413	\$ 435	\$ 456	\$ 1636	\$ 1785
Knife Edge	ATLADM-TSSQR □ 24K	18	0.8	\$ 713	\$ 751	\$ 787	\$ 1933	\$ 2109

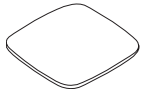

Example of Built-up Table

<p>How to specify — Select the Model Number from above.</p> <p>ATLADM - TSSQR</p>	<p>1st Option: FSC Certified Wood: X Standard - No FSC F FSC Certified</p>	<p>2nd Option: Laminate/Veneer: See page 357 for finishes.</p>	<p>3rd Option: Edge (Laminate): See page 357 for finishes.</p>	<p>3rd Option: Top Finish (Veneer): FF Full Fill +\$282 OP Open Pore Low Sheen</p>
--	--	--	--	--

Example: ATLADM-TSSQRL24F.X.LDW1.DW

Description	Model	Ship Weight	Cubes	List Price	
				P1	P2
Satellite Table Base — Counter Height					
For 24" Diameter	ATLADM-BSATM2424C	58	6.5	\$ 3695	\$ 3928

Note: Base includes tray, 3 power units daisy chained with 20ft braided cord, and 1 wire hook.

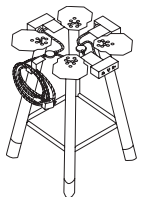

<p>How to specify — Select the Model Number from above.</p> <p>ATLADM - BSATM2424C</p>	<p>1st Option: Paint Color: P1 P2 P3 See page 357 for finishes.</p>	<p>2nd Option: Caster/Glide: CSB Casters Black CSS Casters Silver GLD Glides</p>	<p>3rd Option: Power Color: BLK Black w/ Braided Cord SNW Snow w/ Braided Cord STRM Storm w/ Braided Cord</p>
---	---	--	---

Example: ATLADM-BSATM2424C.P71.GLD.BLK

- Desk pad is vinyl wrapped with a felt bottom to protect worksurface.
- See page 362 for PET wire manager specs and application matrix.

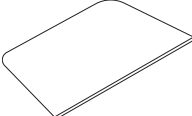

Description	Model	Ship Weight	Cubes	List Price
Home Base Desk Pad — Vinyl Wrapped				
20"W x 33"L x 3½"H	ATLADM-ACCDSKPAD	8	1.3	\$ 950

How to specify —
Select the Model Number from above.

1st Option:
Deskpad Color:
VWH Vinyl – White
VBL Vinyl – Black

ATLADM - ACCDSKPAD .

Example: ATLADM-ACCDSKPAD.VWH

ADMIX

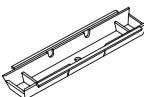

Description	Model	Ship Weight	Cubes	List Price
Under Table PET Wire Tray				
PET Wire Manager 18"W	ATLADM-ACCWIREMGR18	2	0.6	\$ 974
PET Wire Manager 36"W	ATLADM-ACCWIREMGR36 (shown)	3	1.1	\$ 1025
PET Wire Manager 48"W	ATLADM-ACCWIREMGR48	4	1.4	\$ 1076





How to specify —
Select the Model Number from above.

1st Option:
PET Color:
DGY4 Dark Grey

ATLADM - ACCWIREMGR . DGY4

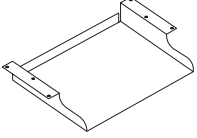
Example: ATLADM-ACCWIREMGR18.DGY4

• See page 362 for vertical wire manager specs.

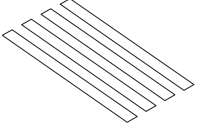
	Description	Model	Ship Weight	Cubes	List Price	
					P1	P2
	Under Table Tray					
	11"W x 13½"L x 5"H	ATLADM-ACCTRAY	5	0.4	\$ 150	\$ 166
	Under Table Bag / Wire Hook					
	4"W x 4"L x 4"H	ATLADM-ACCHOOK	2	0.0	\$ 90	\$ 100
	Replacement Foot — Qty 1					
	With Glide	ATADM-ACCFOOTGLD	3	0.1	\$ 120	\$ 133
	With Caster	ATADM-ACCFOOTCST	2	0.1	\$ 120	\$ 133
	Leg Velcro Wire Strap					
	Kit of 4 (for 1 leg)	ATLACC-LEGWIRESTP	3	0.1	\$ 85	N/A
	Vertical Wire Manager — Leg					
	20" for Continental and Counter Height	ATLACC-LEGWIREMGR20	3	0.1	\$ 120	\$ 133
	22" for Standard Height	ATLACC-LEGWIREMGR22	4	0.1	\$ 125	\$ 139
		(shown)				
	26" for Bar Height	ATLACC-LEGWIREMGR26	5	0.2	\$ 140	\$ 155



<p><i>How to specify —</i></p> <p>Select the Model Number from above.</p>	<p><i>1st Option:</i></p> <p>Paint Color (if applicable):</p> <p>Ⓟ₁ Ⓟ₂ Ⓟ₃</p> <p>See page 357 for finishes.</p>
A T L A -	

Example: ATLADM-ACCTRAY.P71

- External worksurface support stiffeners shown for replacement purposes only. Appropriate worksurface supports are included with bases.
- Tech module fits C1TM and C2TM worksurface cutouts only. See page 361 for spec info.

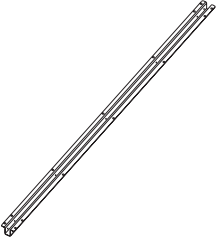

Description	Model	Ship Weight	Cubes	List Price P1
Replacement External Worksurface Support Channel (no color option) — 1½"H				
30"W External Support Channel	Z5SC42 S			\$ 86
36"W External Support Channel	Z5SC48 S			\$ 89
42"W External Support Channel	Z5SC54 S			\$ 102
48"W External Support Channel	Z5SC60			\$ 110
54"W External Support Channel	Z5SC66			\$ 128
60"W External Support Channel	Z5SC72			\$ 137
66"W External Support Channel	Z5SC78			\$ 150
72"W External Support Channel	Z5SC84			\$ 165

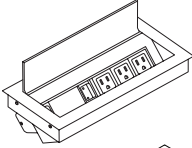

Tech Module — Standard Plug Power Solutions (Surface Mounted)				
10' corded power includes 4 power/2 data ports	AMPTP1	5.0	0.4	\$ 971
10' corded power includes 3 power/1 Extron cut-out	AMPTP2 (shown)	5.0	0.4	\$ 863
10' corded power includes 3 power/1 USB-A, 1 USB-C/2 data ports	AMPTP3	5.0	0.4	\$ 1083
10' corded power includes 3 power/1 USB-A, 1 USB-C/Wireless Charging	AMPTP4	5.0	0.4	\$ 1296

Note: For use with C1, C2, and C3 cutouts.

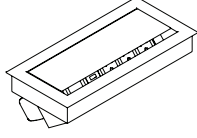

Tech Module — Hardwire Power Solutions (Surface Mounted)				
10' hardwire power includes 4 power/2 data ports	AMPTP1HW	5.0	0.4	\$ 1115
10' hardwire power includes 3 power/1 Extron cut-out	AMPTP2HW (shown)	5.0	0.4	\$ 1006
10' hardwire power includes 3 power/1 USB-A, 1 USB-C/2 data ports	AMPTP3HW	5.0	0.4	\$ 1225
10' hardwire power includes 3 power/1 USB-A, 1 USB-C/Wireless Charging	AMPTP4HW	5.0	0.4	\$ 1429

Note: For use with C1, C2, and C3 cutouts.

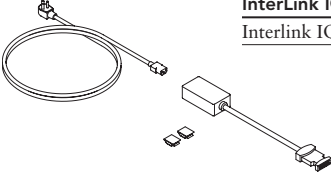

InterLink IQ				
Interlink IQ Starter with 72" Infeed cord	AW4QBI	2.0	0.2	\$ 853

Interlink IQ 36" Jumper	AW4QJ36	2.0	0.2	\$ 171
-------------------------	---------	-----	-----	--------

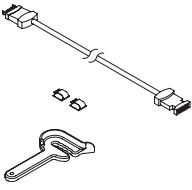

Ganging Bracket				
Bracket includes Hardware	AW4GANG	0.2	0.0	\$ 101

Note: For use on reconfigurable tables.

<p>How to specify — Select the Model Number from above.</p>	<p>1st Option: Paint Color (if applicable): P1 P2 P3 See page 357 for finishes.</p>
--	---

Example: Z5SC42

ADMIX

- Bezel mount power fits C1E and C2E worksurface cutouts only. See page 361 for spec info.
- See page 394 for Interlink IQ infeed and jumper.

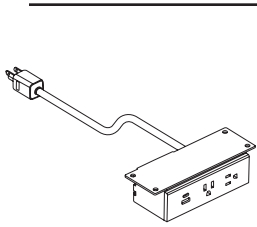

AUPWRMOD.AC.S

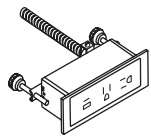

Description	Model	Ship Weight	Cubes	List Price P1
Power Module — Under Worksurface, Rectangular				
7¾"W x 9¼"D x 5¼"H	AUPWRMOD			\$ 761
<ul style="list-style-type: none"> • 2 receptacles, 1 USB-A, & 1 USB-C (AC) • Power cord choices include a 10' Straight (S), 5' Interlink (I), 10' Hardwire (H), and 10' Chevron Fog & Storm Braided (B) cord. • Available in Snow (SNW), Storm (STRM), & Black (BLK). • Example: AUPWRMOD.AC.S.BLK 				
Bezel Mount Power Module				
5¼"H x 9¼"L x 7¾"W	ABPWRMOD	4.5	0.2	\$ 761

ADMIX

<p><i>How to specify —</i> Select the Model Number from above.</p>	<p><i>1st Option:</i> Select Port: AC USB-A/C</p>	<p><i>2nd Option:</i> Select Cord: S Straight B Braided (+\$52) I Interlink (+\$31) H Hardwire (+\$73)</p>	<p><i>3rd Option:</i> Select Plastic: SNW Snow STRM Storm BLK Black</p>
<p>A P W R M O D .</p>	<p>A C .</p>	<p> .</p>	<p> .</p>

Example: AUPWRMOD.AC.S.SNW

- Software support packages furnished to the customer, either by Allsteel® or by another source, which support the sale of Allsteel products are superseded by printed price lists.
- Prices are subject to change without notice. All orders are subject to prices in effect at the time of order.
- Please refer to your Allsteel Dealer Sales and Discount Policies for order placement information, terms and conditions.
- Additional copies of this Specification and Price List are available upon request from Allsteel Literature at 1-866-255-7833.

- Ordering information appears at the bottom of each product page complete with examples on how to specify. Fabric and finish pages are referenced at the bottom of product pages.

This publication is available as an interactive or downloadable PDF at www.allsteeloffice.com.

Questions or Comments?

Please call us at: **888-ALLSTEEL**
888-255-7833

Paint Finishes, Laminates, Eased Edge	398
Fabrics.....	399
Working with Height-Adjustable Tables	400-405.2
Screens and Power Module	406
Altitude - Metal Screens.....	407-408
Power Rail Specifications	409-415
General Overview	409
Power Rail Typical.....	410
Working with Altitude Power Rails	411
Low Rail with Floor Legs	411
Raised Rail.....	411
Screens	411
Working with Cable Management	412
Working with Power Rail Electricals	413
General Notes about Electrical and Circuitry	413
Electrical Infeeds.....	413
Routing Power.....	414-415
Working with Electrical and Data	416-420
Working with Organization Rail & Accessories & Screens.....	421
Altitude Height-Adjustable Tops, Bases, & Accessories.....	422-427.3
Altitude – A6.....	422-423
Worksurfaces for Height-Adjustable Bases	424-426
Cable Management.....	427-427.3
Power Rail – Electrical Components	428-430
A8 Screen Kits.....	431
Metal Screens and Tackboard Accessories.....	432-433
Power Rails and Accessories	434-437
Worksurface Mounted Rail and Accessories	438

BASE COLORS

GRADE P1

Black.....	P71
Brownstone.....	P7D
Cinder.....	P7Q
Cove.....	P096
Designer White.....	PJW
Dune.....	P094
Flint.....	P02
Fossil.....	P28
Harbor.....	P097
Loft.....	P7B
Muslin.....	P4J
Nickel.....	P8L
Parchment.....	P93
Pebble.....	P8R
Pewter.....	P8D
Sage.....	P095
Salt.....	P8C
Titanium.....	P8T

GRADE P2

Champagne Metallic.....	PR5
Gunmetal Metallic.....	PR3
Night Bronze.....	P8B
Platinum Metallic.....	PR2
Silver.....	PR6

GRADE P3

Bullseye*.....	PJF
Regatta*.....	P8M

***Altitude Basic is only offered in one finish, Silver (SVR)

POWER RAIL PAINT COLORS

GRADE P1

Black.....	P71
Brownstone.....	P7D
Bungalow.....	P7C
Cinder.....	P7Q
Designer White.....	PJW
Flint.....	P02
Fossil.....	P28
Loft.....	P7B
Muslin.....	P4J
Pebble.....	P8R
Pewter.....	P8D
Salt.....	P8C
Titanium.....	P8T

GRADE P2

Champagne Metallic.....	PR5
Gunmetal Metallic.....	PR3
Night Bronze.....	P8B
Pyrite.....	PJE
Silver.....	PR6
Solar Black.....	P8X

GRADE P3

Atom.....	P8S
Blossom***.....	P8K
Ember.....	P8P
Ion.....	P8N
Iris.....	P8J
Krypton.....	P8F
Ochre.....	P093
Regatta.....	P8M
Sienna.....	P092
Succulent***.....	P8A

***These colors are intended to be an inspirational option for the trending market. Product application is limited and color availability is approximately two years to coincide with evolving workplace trends.

A8 SCREEN BRACKET PAINT COLORS

GRADE P1

Black.....	P71
Designer White.....	PJW

GRADE P2

Silver.....	PR6
-------------	-----

LAMINATES

GRADE L1

SOLID COLORS	
Black.....	P
Brownstone.....	LM13
Bungalow.....	LM12
Designer White.....	LDW1
Flint.....	LM16
Fossil Shale.....	LEH1
Loft.....	LM11
Muslin.....	LM15
Titanium.....	LTI1

ABSTRACT

Ash.....	LT3B
Handspun Pearl.....	LAHP
Handspun Dove.....	LAHD
Handspun Slate.....	LAHS
Handspun Chestnut.....	LAHC
Silver Mesh.....	LT8D

WOODGRAIN

Belair.....	LWBA
Bourbon Cherry.....	H
Field Elm.....	LWFE
Florence Walnut.....	LFW1
Kingswood Walnut.....	LK11
Natural Maple.....	LWD
NeoWalnut.....	LNU1
Pinnacle.....	PINC
Shaker Cherry.....	LW7C

GRADE L2

Beigewood.....	LWBE
Fawn Cypress.....	LFC1
Lowell Ash.....	LLA1
Mangalore Mango.....	LMM1
Natural Recon.....	LNR1
Phantom Charcoal.....	LPC1
Phantom Ecru.....	LPE1
Portico Teak.....	LPT1
Skyline Walnut.....	LSW1
Veranda Teak.....	LVT1

GRADE L3

Natural Walnut.....	LWNW
---------------------	------

EASED EDGE LAMINATES

GRADE L1

Designer White.....	LDW1
Loft.....	LM11
Natural Maple.....	LWD

GRADE L2

Natural Recon.....	LNR1
--------------------	------

STRAIGHT/ROUNDED EDGE COLORS

Beigewood.....	DE
Belair.....	BA
Black.....	E4
Bourbon Cherry.....	H
Brownstone.....	EY
Bungalow.....	EX
Designer White.....	DW
Fawn Cypress.....	FC
Field Elm.....	FE
Flint.....	E9
Florence Walnut.....	FW
Fossil.....	EH
Kingswood Walnut.....	KI
Loft.....	EV
Lowell Ash.....	DL
Mangalore Mango.....	MM
Muslin.....	EU
Natural Maple.....	DD
Natural Recon.....	NR
Natural Walnut.....	DN
NeoWalnut.....	NU
Parchment.....	EN
Phantom Charcoal.....	PC
Phantom Ecru.....	PE
Pinnacle.....	PI
Platinum Metallic.....	EP
Plyband.....	PL
Portico Teak.....	DP
Shaker Cherry.....	DF
Skyline Walnut.....	SW
Titanium.....	TI
Veranda Teak.....	VT

ELECTRICAL & DATA COMPONENTS

Black.....	E4
Brownstone.....	EY
Designer White.....	DW
Flint.....	E9
Loft.....	EV
Muslin.....	EU
Silver.....	ES

METAL ACCESSORIES PAINT COLORS

GRADE P1

Black.....	P71
Brownstone.....	P7D
Bungalow.....	P7C
Charblack.....	CBK
Cinder.....	P7Q
Cove.....	P096
Designer White.....	PJW
Dune.....	P094
Flint.....	P02
Fossil.....	P28
Harbor.....	P097
Loft.....	P7B
Muslin.....	P4J
Parchment.....	P93
Pebble.....	P8R
Pewter.....	P8D
Platinum Metallic Texture.....	P6H
Sage.....	P095
Salt.....	P8C
Textured Brownstone.....	P7J
Textured Designer White.....	PK7
Textured Flint.....	P7A
Textured Loft.....	P7L
Textured Muslin.....	P7M
Textured Pebble.....	P8Y
Textured Salt.....	P8Z
Textured Titanium.....	P8V
Titanium.....	P8T
White.....	PD8

GRADE P2

Champagne Metallic.....	PR5
Graphite Metallic Texture.....	P85
Gunmetal Metallic.....	PR3
Matte Gold.....	P8G
Night Bronze.....	P8B
Platinum Metallic.....	PR2
Pyrite.....	PJE
Silver.....	PR6
Silver Generic.....	SVR
Silver Texture.....	PR8
Solar Black.....	P8X

GRADE P3

Atom.....	P8S
Blossom.....	P8K
Bullseye.....	PJF
Ember.....	P8P
Ion.....	P8N
Iris.....	P8J
Krypton.....	P8F
Regatta.....	P8M
Succulent.....	P8A
Ochre.....	P093
Sienna.....	P092

All of Allsteel's tables are level® – 2 certified to the ANSI/BIFMA e3 Furniture Sustainability Standard. See www.levelcertified.org for more information.

NOTE: Refer to individual product pages for upcharges.

Fabrics

For use with Screen Kits.

GSA Reference Page

GRADE A

NOBLE

Aegean	NBLE18
Amethyst.....	NBLE19
Aspen	NBLE14
Aster	NBLE20
Blossom.....	NBLE21
Bluebell	NBLE22
Bordeaux.....	NBLE01
Brick	NBLE02
Chambray	NBLE10
Chamomile.....	NBLE23
Clementine	NBLE04
Conifer.....	NBLE24
Cottage	NBLE25
Darkness	NBLE26
Dawn	NBLE13
Denim	NBLE09
Desert Sand	NBLE27
Dewfall	NBLE28
Dusted Sage.....	NBLE29
Flax.....	NBLE30
Grass.....	NBLE07
Gunmetal	NBLE15
Harmony.....	NBLE31
Harvest	NBLE12
Ice Caves	NBLE32
Icicle.....	NBLE33
Inky.....	NBLE34
Iris.....	NBLE35
Jade.....	NBLE06
Knight	NBLE17
Mesa	NBLE03
Monarch	NBLE36
Pacific	NBLE08
Pitch.....	NBLE37
Queen Bee	NBLE38
Rainforest	NBLE05
Regal.....	NBLE11
Sandcastle	NBLE39
Sedona	NBLE40
Stormy	NBLE16
Sunbeam	NBLE41
Voyager.....	NBLE42
Windy Day	NBLE43

GRADE D

BLAZER LITE
(100% Pure New Wool)

Angel.....	LTH49
Aspire.....	LTH52
Balance.....	LTH41
Bliss.....	LTH48
Buddha.....	LTH56
Cuddle	LTH62
Dainty	LTH64
Daydream	LTH46
Devoted.....	LTH58
Faith.....	LTH68
Freedom	LTH69
Graceful	LTH51
Happy	LTH55
Harmony.....	LTH63
Haven	LTH40
Hope	LTH50
Hush	LTH42
Love	LTH47
Mood	LTH44
Pamper.....	LTH66
Pastel.....	LTH65
Pillow.....	LTH43
Praise	LTH54
Retreat	LTH39
Shelter	LTH60
Solace.....	LTH70
Tender.....	LTH53
True	LTH61
Verity	LTH57
Wish.....	LTH67
Worship	LTH59

ALTITUDE

Altitude height-adjustable bases are available in five styles:

A6

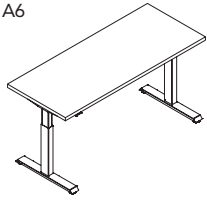

T-leg with
Rectangular Worksurface

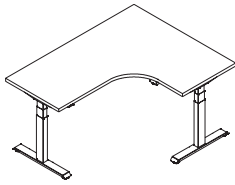

T-leg with
Corner Cove Worksurface

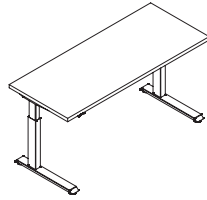

C-leg with
Rectangular Worksurface

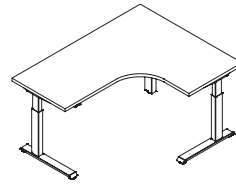

C-leg with
Corner Cove Worksurface

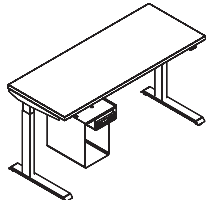

Altitude HAT
with Undermount
Radii Console

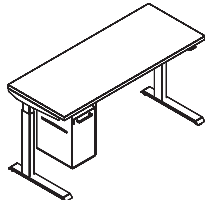

Altitude HAT
with Flush Undermount
Radii

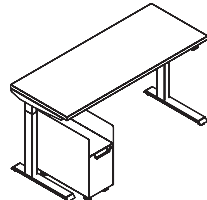

Altitude HAT
with Freestanding Mobile
Alcove Radii

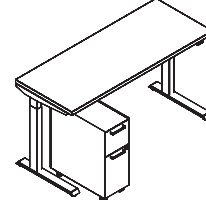

Altitude HAT
with Freestanding Mobile
Alcove Radii

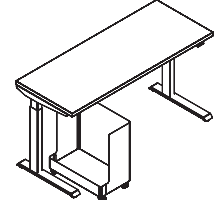

Altitude HAT with
Freestanding Mobile
Radii Caddy

A8 Screens

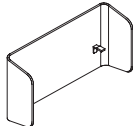

U Screen Kit

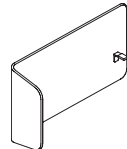

L Screen Kit (Left)

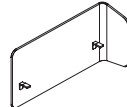

L Screen Kit (Right)

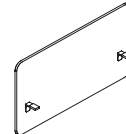

Rectangular Screen Kit

Metal Screens



L Screen (Left)



L Screen (Right)



U Screen

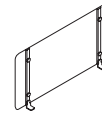

Straight

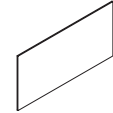

Tackboard Accessory

Altitude Power Rail

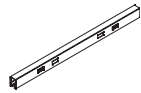

Altitude Power Rail

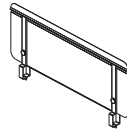

Altitude Rail Screen

A6 Clearance Dimensions

Rectangle

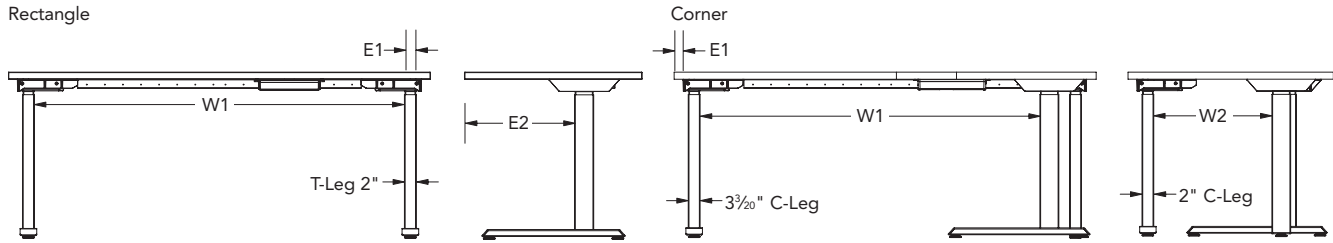

Base Style:	A6-T Base				A6-C Base				
	Dimension Location:	E1	W1	W2	E2	E1	W1	W2	E2
Altitude Top: (Surface dimensions are nominal. Actual widths are reduced by 2")	Edge of table to outside of leg	Between legs	Between legs	Edge of table to the outside of leg	Edge of table to outside of leg	Between legs	Between legs	Edge of table to the outside of leg	
24" x 48" Rectangle*	2½"	35¼"	—	10%"	2½"	35¼"	—	14¼"	
24" x 54" Rectangle	2½"	41¼"	—	10%"	2½"	41¼"	—	14¼"	
24" x 60" Rectangle	2½"	47¼"	—	10%"	2½"	47¼"	—	14¼"	
24" x 66" Rectangle	2½"	53¼"	—	10%"	2½"	53¼"	—	14¼"	
24" x 72" Rectangle	2½"	59¼"	—	10%"	2½"	59¼"	—	14¼"	
30" x 48" Rectangle	2½"	35¼"	—	13%"	2½"	35¼"	—	17%"	
30" x 54" Rectangle	2½"	41¼"	—	13%"	2½"	41¼"	—	17%"	
30" x 60" Rectangle	2½"	47¼"	—	13%"	2½"	47¼"	—	17%"	
30" x 66" Rectangle	2½"	53¼"	—	13%"	2½"	53¼"	—	17%"	
30" x 72" Rectangle	2½"	59¼"	—	13%"	2½"	59¼"	—	17%"	
60" x 36" Corner Cove	2½"	43"	26"	10%"	2½"	43"	29½"	14¼"	
60" x 48" Corner Cove	2½"	43"	32"	10%"	2½"	43"	35½"	14¼"	
72" x 36" Corner Cove	2½"	55"	26"	10%"	2½"	55"	29½"	14¼"	
72" x 48" Corner Cove	2½"	55"	32"	10%"	2½"	55"	35½"	14¼"	

Bottom Views

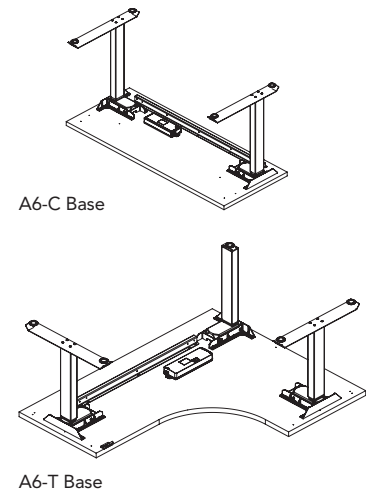

Feature	Altitude Basic	A6
Range Adjustment	26¼" – 43½"H + Adjustable Glide	2-Stage 26½" to 45¼" + ½" Adjustable Glide
Base Only, Without Work Surface		3-Stage 21¼" to 47½" + ½" Adjustable Glide
Range Adjustment	27%" to 44"H + Adjustable Glide	2-Stage 27%" to 46%" + ½" Adjustable Glide
Includes Standard Allsteel 1½" Work Surface		3-Stage 22¼" to 48%" + ½" Adjustable Glide
Foot Configuration	<ul style="list-style-type: none"> T Foot Standard leveling glide 	<ul style="list-style-type: none"> T Foot or C Foot Standard options include leveling glide, slide glides, and casters
Leg Options	2 leg	2 and 3 leg
UL Certified Weight Rating	180 lbs	<ul style="list-style-type: none"> 250 lbs for 2-leg 350 lbs for 2-leg Max 375 lbs for 3-leg 500 lbs for 3-leg Max
Cross Bar Design	Yes	A6 models ordered prior to 4/5/2021 have cross bar understructure, A6 models ordered after 4/5/2021 do not
Colors	Silver Only	20 Allsteel Paint Finishes offered, see Altitude Tables Finishes page
Control Pad	Up/down only	Basic up/down, memory preset, paddle, foot pedal
Wire Management	Allsteel standard options available Hinged trough not recommended	Allsteel standard options available
Power Access	Desktop power modules available	Desktop power modules available
Warranty	5 years	If Purchased Before 3/1/2021: 10 Years Metal Base, 7 Years Electronics If Purchased After 3/1/2021: 10 Years for Entire Product

Height-Adjustable Worksurfaces, Bases, and Controls

Height-Adjustable Worksurfaces (page 424)

- Height-adjustable worksurfaces are available in laminate with flat edge and rectangular veneer with matching square edge.
- T-mold is used on the edge of curved worksurfaces. This will have a noticeable visual difference when directly adjacent to straight worksurfaces.
- Worksurface dimensions are nominal. Actual widths are reduced by 2" (1" each side) and worksurface depths are reduced by ¼". Corner cove depth is nominal, actual is 1" less.
- Rectangular undersized worksurface models' (model number ending in -U) actual widths and depths are reduced by 2".
- Corner Cove undersized worksurface models' (model number ending in -LD) actual dimensions are reduced by 2".
- Altitude worksurfaces are pre-drilled with mounting location for bases.
- Rectangular worksurface grommet location is limited to center location due to mounting of worksurface supports at each end of the worksurface.
- Certain two-piece top configurations may require two stiffeners depending on the footprint of your station.
- 2-leg standard bases can accommodate worksurface configurations from 24"D x 24"W to 30"D x 72"W.
- 2-leg Max bases can accommodate worksurface configurations from 24"D x 24"W to 30"D x 96"W.
- 3-Leg standard bases can accommodate worksurface configurations from 24"D x 48"W x 36"W to 30"D x 72"W x 48"W.
- 3-Leg Max bases can accommodate worksurface configurations from 24"D x 48"W x 36"W to 30"D x 72"W x 72"W.
- Altitude A6 bases specified with a work surface 60"W and greater require the use of an external stiffener. An external stiffener is included in Altitude work surface models 60"W and greater (all models ending with letter -D). If a non-Altitude work surface is being used, an external stiffener may need to be specified separately.

Height-Adjustable Bases (pages 422-423)

- Electronic height-adjustable base units are available in six styles: A6-T Base with 2 legs, A6-C Base with 2 legs, A6-T Base with 3 legs, A6-C Base with 3 legs, A6-T Max Base with 2 legs, A6-C Max Base with 2 legs, A6-T Max Base with 3 legs, and A6-C Max Base with 3 legs.
- **A6 2-stage and 3-stage have a travel speed of 1.25"/second. A-6 Max bases have a travel speed of 1.96"/second.** Motor devices have a continuous cycle time of 2 minutes with an 18 minute rest period before it can be cycled again.
- Control box is powered by 110-120V/60Hz/4A. Standby power is < 0.1 Watts. Power cords on A6-T models are 10'.
- Pedestals taller than 24½" for 2-stage models and 19½" for 3-stage models when placed under table will limit range in lowest position.
- Mobile box/file pedestals will clear feet on height adjustable base but will extend past edge of worksurface in that position. See chart on page 401.
- Moving worksurfaces can collide with other components. It is important to ensure free range of motion prior to operating the table.
- All tables have adjustable glides providing ½" adjustment on A6.
- Slide glides offered as a .option and model level. Only available on 2-leg bases.
- Casters available on model level for retrofitting on 2-Leg Bases ONLY.
- Altitude A6 tables feature collision detection, a feature designed to stop table travel when the table detects an obstacle.
- A6 load capacity is 250 lbs for 2-leg models, 375 lbs for 3-leg models, 350 lbs for 2-leg Max models, and 500 lbs for 3-leg Max models. This includes the weight of the worksurface.

A6 Control Options

- Memory Controls are now a .option.
- Up/Down: Basic Up/Down control.
- Memory Control: 4 memory pre-set options allow the user to adjust their height to their preferred heights.
- Paddle: Simple, aesthetic control with 1 memory pre-set option and reminder mode.
- Bluetooth Capability: A6 optional Bluetooth capability is sold as accessory model A6BLUETOOTH. Bluetooth is enabled through smartphone app AiDesk. Bluetooth control will only work with 2-leg A6 tables. Bluetooth control will **not** work with 3-leg A6 tables. No additional controls are required for use, but they can be used in addition to the bluetooth control (bluetooth plug in uses different port than other controls).

Note: HAT-to-Panel bracket does not work with the Max Base.

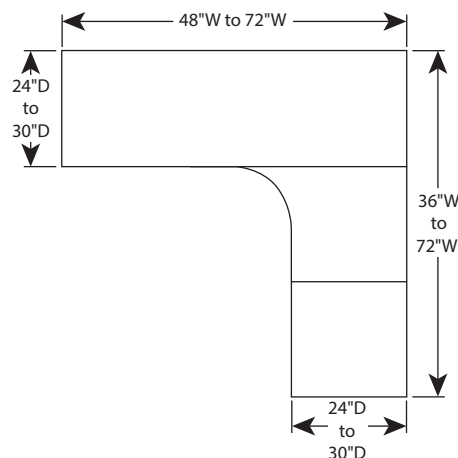
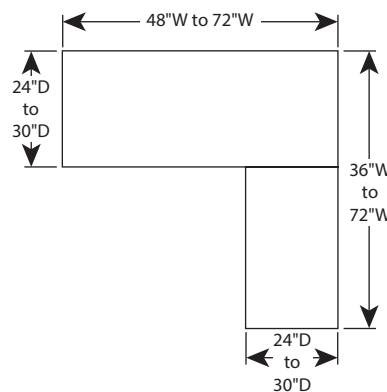
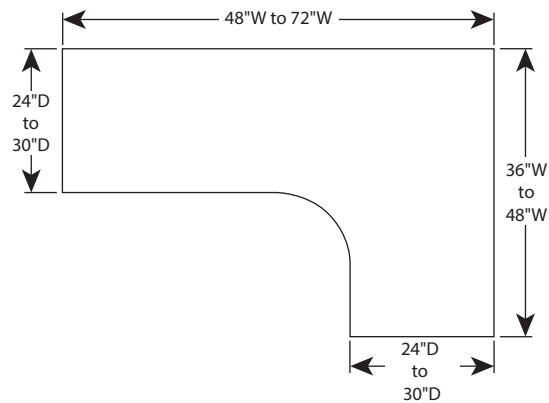

For specification information see page 402.

Rectangular Laminate Tops – 24"D

Base Model(s)	Actual Dimensions
AF5RS4824, AVF5RS4824	46"W x 23¼"D
AF5RS5424, AVF5RS5424	52"W x 23¼"D
AF5RS6024D, AVF5RS6024D	58"W x 23¼"D
AF5RS6624D, AVF5RS6624D	64"W x 23¼"D
AF5RS7224D, AVF5RS7224D	70"W x 23¼"D
AF5RS7824D	76"W x 23¼"D
AF5RS8424D	82"W x 23¼"D
AF5RS9024D	88"W x 23¼"D
AF5RS9624D	94"W x 23¼"D

Rounded Corner Laminate Tops – 24"D

Base Model(s)	Actual Dimensions
AF5RND4824	46"W x 23¼"D
AF5RND5424	52"W x 23¼"D
AF5RND6024D	58"W x 23¼"D
AF5RND6624D	64"W x 23¼"D
AF5RND7224D	70"W x 23¼"D
AF5RND7824D	76"W x 23¼"D
AF5RND8424D	82"W x 23¼"D
AF5RND9024D	88"W x 23¼"D
AF5RND9624D	94"W x 23¼"D

Rectangular Laminate Tops – 30"D

Base Model(s)	Actual Dimensions
AF5RS4830, AVF5RS4830	46"W x 29¼"D
AF5RS5430, AVF5RS5430	52"W x 29¼"D
AF5RS6030D, AVF5RS6030D	58"W x 29¼"D
AF5RS6630D, AVF5RS6630D	64"W x 29¼"D
AF5RS7230D, AVF5RS7230D	70"W x 29¼"D
AF5RS7830D	76"W x 29¼"D
AF5RS8430D	82"W x 29¼"D
AF5RS9030D	88"W x 29¼"D
AF5RS9630D	94"W x 29¼"D

Rounded Corner Laminate Tops – 30"D

Base Model(s)	Actual Dimensions
AF5RND4830	46"W x 29¼"D
AF5RND5430	52"W x 29¼"D
AF5RND6030D	58"W x 29¼"D
AF5RND6630D	64"W x 29¼"D
AF5RND7230D	70"W x 29¼"D
AF5RND7830D	76"W x 29¼"D
AF5RND8430D	82"W x 29¼"D
AF5RND9030D	88"W x 29¼"D
AF5RND9630D	94"W x 29¼"D

Undersized Rectangular Worksurface – 24"D

Base Model(s)	Actual Dimensions
AF5RS3624U	34"W x 22"D
AF5RS4224U	40"W x 22"D
AF5RS4824U	46"W x 22"D
AF5RS5424U	52"W x 22"D
AF5RS6024UD	58"W x 22"D
AF5RS6624UD	64"W x 22"D
AF5RS7224UD	70"W x 22"D
AF5RS7824UD	76"W x 22"D
AF5RS8424UD	82"W x 22"D
AF5RS9024UD	88"W x 22"D
AF5RS9624UD	94"W x 22"D

Undersized Rectangular Worksurface – 30"D

Base Model(s)	Actual Dimensions
AF5RS3630U	34"W x 28"D
AF5RS4230U	40"W x 28"D
AF5RS4830U	46"W x 28"D
AF5RS5430U	52"W x 28"D
AF5RS6030UD	58"W x 28"D
AF5RS6630UD	64"W x 28"D
AF5RS7230UD	70"W x 28"D
AF5RS7830UD	76"W x 28"D
AF5RS8430UD	82"W x 28"D
AF5RS9030UD	88"W x 28"D
AF5RS9630UD	94"W x 28"D

120 Degree Corner Worksurface – 24"D

Base Model(s)	Actual Dimensions
AF5120S4224D	22"A x 40"B x 40"C x 22"D
AF5120S4824D	22"A x 46"B x 46"C x 22"D
AF5120S5424D	22"A x 52"B x 52"C x 22"D

120 Degree Corner Worksurface – 30"D

Base Model(s)	Actual Dimensions
AF5120S4224D	28"A x 40"B x 40"C x 28"D
AF5120S4824D	28"A x 46"B x 46"C x 28"D
AF5120S5424D	28"A x 52"B x 52"C x 28"D

For specification information see page 402.

Corner Cove Laminate Tops – 24"D Extended Left

Base Model(s)	Actual Dimensions
A5822ELS	23¼"A x 58¼"B x 34½"C x 23¼"D
A5622ELS	23¼"A x 58¼"B x 46¼"C x 23¼"D
A5922ELS	23¼"A x 70¼"B x 34½"C x 23¼"D
A7222ELS	23¼"A x 70¼"B x 46¼"C x 23¼"D

Undersized Corner Cove Worksurface, Left Hand – 24"D

Base Model(s)	Actual Dimensions
AF5CCS603624LD	22"A x 58"B x 34"C x 22"D
AF5CCS604824LD	22"A x 58"B x 46"C x 22"D
AF5CCS723624LD	22"A x 70"B x 34"C x 22"D
AF6CCS724824LD	22"A x 70"B x 46"C x 22"D

Undersized Corner Cove Worksurface, Left Hand – 30"D

Base Model(s)	Actual Dimensions
AF5CCS604830LD	28"A x 58"B x 46"C x 28"D
AF5CCS724830LD	28"A x 70"B x 46"C x 28"D

Corner Cove Laminate Tops – 24"D Extended Right

Base Model(s)	Actual Dimensions
A5822ERS	23¼"A x 58¼"B x 34½"C x 23¼"D
A5622ERS	23¼"A x 58¼"B x 46¼"C x 23¼"D
A5922ERS	23¼"A x 70¼"B x 34½"C x 23¼"D
A7222ERS	23¼"A x 70¼"B x 46¼"C x 23¼"D

Undersized Corner Cove Worksurface, Right Hand – 24"D

Base Model(s)	Actual Dimensions
AF5CCS603624RD	22"A x 58"B x 34"C x 22"D
AF5CCS604824RD	22"A x 58"B x 46"C x 22"D
AF5CCS723624RD	22"A x 70"B x 34"C x 22"D
AF6CCS724824RD	22"A x 70"B x 46"C x 22"D

Undersized Corner Cove Worksurface, Right Hand – 30"D

Base Model(s)	Actual Dimensions
AF5CCS604830RD	28"A x 58"B x 46"C x 28"D
AF5CCS724830RD	28"A x 70"B x 46"C x 28"D

Cable & Wire Management

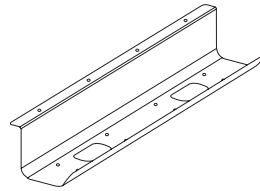

AJTRGH24 or AJTRGH36

Cable Management Tray (page 427)

- Attaches under the worksurface to contain cables.
- Metal tray shelf is 4" deep. Can hold electrical power strip and/or surge protector.
- 24" and 36" lengths, use multiple units for larger worksurfaces.
- Attachment hardware included, paint option is black only.
- Zip tie attachment points located in base of tray. Zip ties not included.

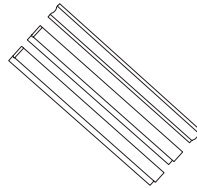

AWRSTRIP

Wire Management Strips/Channels (page 427)

- Self adhesive backing to attach to panels and underside of worksurfaces.
- Flexible strips allow cabling to enter/exit and can be contained inside the strips' cavities.
- Includes two wire management profiles. Smaller profile allows for qty. 3, .3" diameter cords, has area of .32 in². Larger "J" shaped profile allows for qty. 10, .3" diameter cords, has area of 1.14 in².

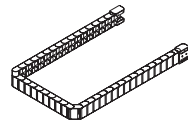

A9CLWMC or WKSWMC

Cord Management Chains (page 427)

- Works with Approach and Altitude A6-units.
- Used to route and conceal power/data cables from control box and other devices. Includes all mounting hardware and a plate to secure to a leveling glide.
- Houses 6 cables at 0.300" diameter.
- Made of plastic chain with plastic attachment brackets at each end.
- Specify WKSWMC for 58" chain. Only comes in Black finish.
- Specify A9CLWMC for 36" chain. Comes in Black, White, and Silver.
- Has two connecting points: Top section connects underneath a worksurface and bottom section can connect underneath power rails or to panel raceways using double-sided tape. Hardware included.

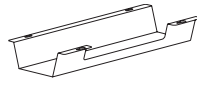

APWRTRGH17 or APWRTRGH36

Under Worksurface Trough (page 427)

- Used to conceal wires and control box below worksurfaces. Trough can be configured at various height/width combinations to meet capacity needs. Ships flat and is bent to desired shape.
- On 48"W and 54"W worksurfaces use one 17"W trough. 54"W has space to use 2 – 17"W, if necessary.
- On 60"W, 66"W, and 72"W worksurfaces use the 36" trough.
- On 84"W worksurface use 2 – 17"W troughs.

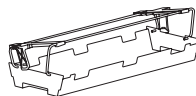

AFDTRGH20

Flip-Down Wire Trough (page 427)

- Mounts beneath a worksurface. Used to conceal extra cord slack and power strips.
- May be used in conjunction with quad tap unit APWR4TAP to reduce the number of cords routed from a worksurface to a beam.
- For any worksurface less than 58"W, a 20"W Flip-Down Trough is recommended.
- For worksurfaces 58"W and wider, a 20"W or 32"W Flip-Down Trough may be used.
- Flush-mount Raddi Storages are not recommended to use in conjunction with Flip-Down Trough.
- Only AKTSHORT keyboard tray is recommended for use in conjunction with the Flip-Down Trough.

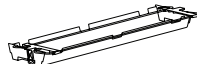

AFDTRGH32

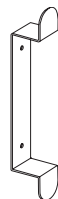

AWIRECLT

Metal Wire Cleat (page 427)

- Supplied with screws and VHB tape for attachment to various surface types.
- For wood/particle board/MDF surfaces, use screw attachment.
- For painted metal/glass/non-porous surfaces, use VHB tape.
- Example use cases:
 - 1) Used alongside telescoping/fabric HAT wire chases to secure excess length of cord at plug-end.
 - 2) Secured to wall next to TV monitor in meeting room to manage HDMI cable when not in use.
 - 3) Screwed underneath worksurface to provide quick and easy management of excess length of cords and cabling.

Cable & Wire Management

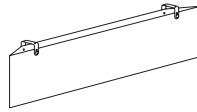

APWRMODEST36 or APWRMODEST48

Fabric Power Modesty (page 427.2)

- Fabric Power Modesty presents as modesty panel hanging by leather straps under a worksurface; inner compartment conceals cords and power strips as a wire management application.
- Recommended worksurface width pairings:
 - 1) 48-60" W Desk — Use APWRMODEST36 Centered.
 - 2) 66-72" W Desk — Use APWRMODEST48 Centered or APWRMODEST36 offset.
 - 3) 84" W Desk — Use APWRMODEST48 offset.
- Modesty fills 11.5 inches below the bottom of the worksurface with space for cords to enter/exit between the worksurface and the top of the Power Modesty.
- Two entry/exit points for cords are located at the bottom of the Power Modesty unit.
- Modesty panel is designed to present as a thin modesty panel from the front, but provides 3" depth cavity for wires, power strips, etc.
- Maximum weight capacity for Power Modesty is 25 lbs.
- Modesty panel not to be used to store electronics that require airflow for thermal management (computers).
- Users can access interior of panel (to modify wire placement) via "wings" on either side of product, secured via user-operable Velcro connection.
- Users may also dismount Power Modesty from leather straps by unlooping leather straps from button attachments.
- Leather straps on Power Modesty always come in medium brown color.
- Power Modesty available in Appoint, Binary, Centurion, Noble, Reflections, Disperse, and Spin fabric series.

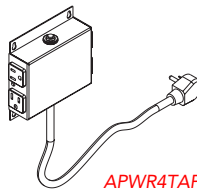

APWR4TAP

Power Module — Under Worksurface, Quad Tap (page 427.1)

- Under surface mounting, used on any worksurface with a 5" x 5" x 1.5" clearance.
- 10' Power cord. UL Listed.
- May be used in conjunction with Flip-Down Trough to reduce the number of cords routed from a worksurface to a beam.
- 4 receptacles, unit is black finish only, no specification needed.

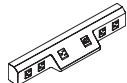

FDPWRC, CFDPWRC, FDPWRSC, or CFDPWRSC

Concealed Power Module (page 427.1)

- Contains 5 simplex outlets, 1 USB-A, and 1 USB-C.
- Available in plastic or metal. Metal power module is required for Chicago code.
- Cord options include straight and curly.
 - Straight cord is 144"
 - Curly cord is 120"
- If desired application is to set power module inside an under worksurface trough, MUST be specified with SPLA-ALT-BEAMA (contact Allsteel TPG for more information).
- Cannot be attached directly to the bottom of the worksurface.

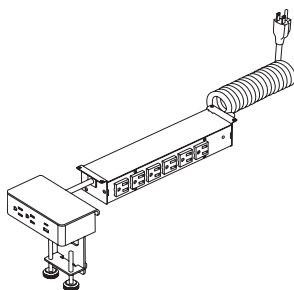

AABPWRMOD.AC.Q

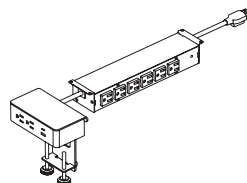

AABPWRMOD.AC.S

Power Module — Above/Below Worksurface (page 427.2)

- Above/Below power module provides access to power on the desktop and below the worksurface.
- Desktop mount can be used on any surface with a 6" W x 3" D clearance along the worksurface edge.
- Under surface mounting can be used with a 12" W x 3" D x 2" H clearance under the surface.
- Plugs will take additional depth (approx. 3").
- Two wire management "P-Clips" included with mounting hardware.
- Below worksurface power strip supplies six grounded A/C receptacles, desktop unit supplies two receptacles, 1 USB-A port, and 1 USB-C port.
- Desktop and under worksurface units are connected by a 2' long straight cord and cannot be disconnected.
- Power cord choices include a 6' straight cord or a coiled cord that is 6' long uncoiled, approximately 8" long coiled (compressed).
- Desktop unit available in White and Gray finishes.
- Under worksurface unit available in black only, no specification needed.
- UL 962A and UL 111 Listed. UL 1310 Recognized.

Cable & Wire Management

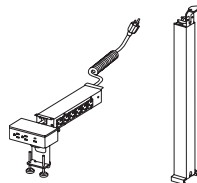

AHATPWORMOD2S or AHATPWORMOD3S

Metal Telescoping HAT Wire Management (page 427.3)

- Separate models available for use on either 2-Stage or 3-Stage Altitude A6 Tables. Not compatible with Altitude A3, A5, or A8.
- Equipped with 2-Stage or 3-Stage Telescoping Wire Chase and custom Above/Below Power Module intended for cord management on 2- and 3-Stage height adjustable tables.
- Telescoping chase includes a unique Above/Below Power Module and is NOT compatible with any other power module.
- Above/Below Power Module supplies 6 grounded A/C receptacles below the worksurface and 2 receptacles, 1 USB-A, and 1 USB-C port above the worksurface on the desktop unit. Desktop power module available in White and Gray finishes, below-worksurface power strip only available in black only.
- Telescoping Chase available in the same paint finishes as the Altitude height adjustable bases except for “Nickel.”
- To match Metal Telescoping Chase to HAT base, specify matching paint color as HAT base. To match Telescoping Chase to a “Nickel” HAT base, specify “Platinum Metallic,” or “PR2.”
- Two “P-Clips” included for wire management between desktop power module and under worksurface power strip.

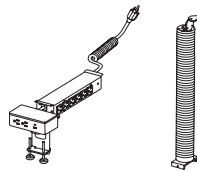

AHATPWORMOD2S or AHATPWORMOD3S

Fabric Elastic HAT Wire Management (page 427.3)

- Model compatible for use on either 2-Stage or 3-Stage Altitude A6 Tables. Not compatible with Altitude A3, A5, or A8.
- Equipped with Fabric Elastic Wire Chase and custom Above/Below Power Module intended for cord management on 2- and 3-Stage height adjustable tables.
- Fabric Elastic Chase includes a unique Above/Below Power Module and is NOT compatible with any other power module.
- Above/Below Power Module supplies 6 grounded A/C receptacles below the worksurface and 2 receptacles, 1 USB-A, and 1 USB-C port above the worksurface on the desktop unit.
- Desktop power module available in White and Gray finishes, below-worksurface power strip only available in black only.
- Fabric Elastic Chase available in Light, Medium, and Dark fabric finishes.
- Includes a metal foot and an under worksurface mounting bracket to attach Fabric Elastic Chase along the side of a HAT leg.
- To match metal brackets to HAT base, specify matching paint color as HAT base. To match brackets to a “Nickel” HAT base, specify “Platinum Metallic,” or “PR2.”
- Two “P-Clips” included for wire management between desktop power module and under worksurface power strip.

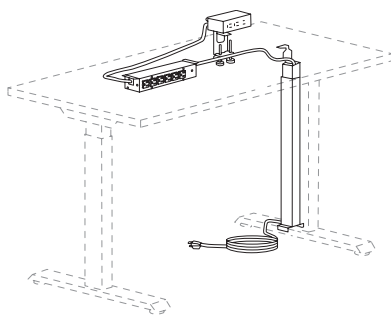

2-Stage Metal Telescoping HAT Wire Management

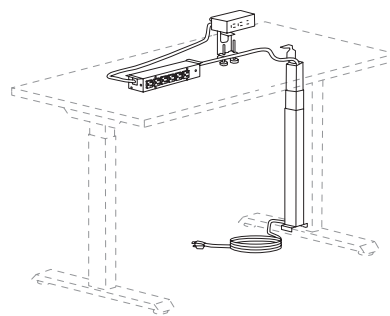

3-Stage Metal Telescoping HAT Wire Management

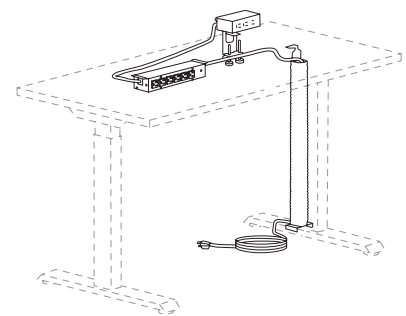

2 or 3-stage Fabric Elastic HAT Wire Management

For more power and wire management options, please visit the Extensions pages.

Screens

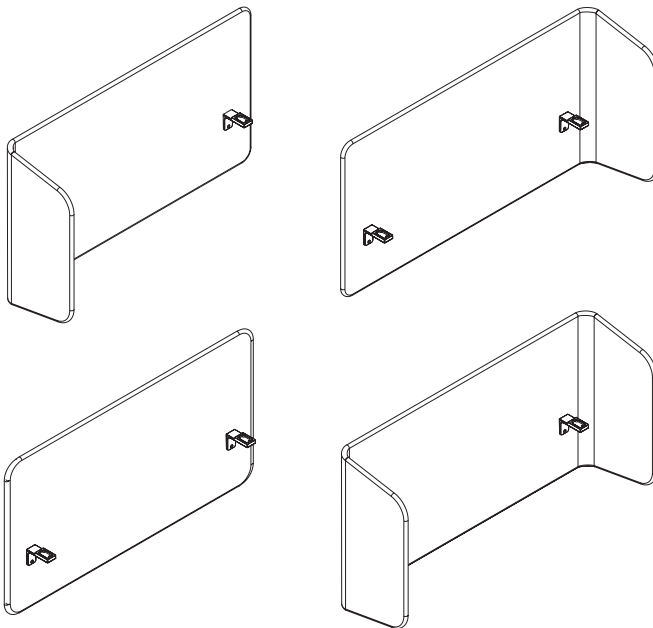

- See Table 1 for overall table width and depth for each screen shape.
- Adding a screen adds 3" to depth of the table.
- Adding a screen adds 1" to the width of the table per return wing.
- RH L-screens have return wing on user's right; LH opposite.
- When using a 24"D worksurface with Altitude screens, you must specify a T-foot.

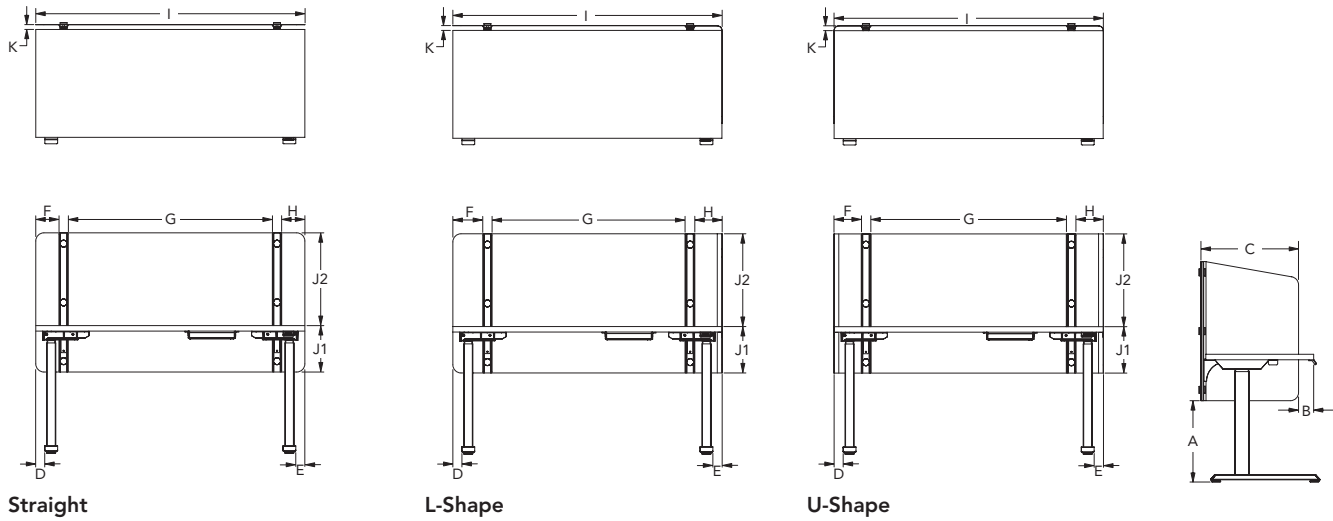

Size Reference Matrix

Models	A	B	C1	C2	D	E	F	G1	G2	H	I	J1	J2	K
	Under Desk Height	Wing to Front	Wing Width STD	Wing Width EXT	Left Leg to Edge	Right Leg to Edge	Left Side Panel to Support	Distance Between Supports	Distance Between Center/Right Support	Right Side Panel to Support	Overall Width	Desktop To Base of Panel	Desktop To Top of Panel	Cable Drop Space
AMS2048LH	24.7	3.3	21.1	24.3	2.0	2.0	5.9	29.7	-	6.4	46.1	2.9	20.0	1.0
AMS2054LH	24.7	3.3	21.1	24.3	2.0	2.0	5.9	35.7	-	6.4	52.1	2.9	20.0	1.0
AMS2060LH	24.7	3.3	21.1	24.3	2.0	2.0	5.9	41.7	-	6.4	58.1	2.9	20.0	1.0
AMS2066LH	24.7	3.3	21.1	24.3	2.0	2.0	5.9	22.8	22.8	6.4	64.1	2.9	20.0	1.0
AMS2072LH	24.7	3.3	21.1	24.3	2.0	2.0	5.9	25.8	25.8	6.4	70.1	2.9	20.0	1.0
AMS2048RH	24.7	3.3	21.1	24.3	2.0	2.0	6.4	29.7	-	5.9	46.1	2.9	20.0	1.0
AMS2054RH	24.7	3.3	21.1	24.3	2.0	2.0	6.4	35.7	-	5.9	52.1	2.9	20.0	1.0
AMS2060RH	24.7	3.3	21.1	24.3	2.0	2.0	6.4	41.7	-	5.9	58.1	2.9	20.0	1.0
AMS2066RH	24.7	3.3	21.1	24.3	2.0	2.0	6.4	22.8	22.8	5.9	64.1	2.9	20.0	1.0
AMS2072RH	24.7	3.3	21.1	24.3	2.0	2.0	6.4	25.8	25.8	5.9	70.1	2.9	20.0	1.0
AMS3248LH	17.5	3.3	21.1	24.3	2.0	2.0	5.9	29.7	-	6.4	46.1	10.0	20.0	1.0
AMS3254LH	17.5	3.3	21.1	24.3	2.0	2.0	5.9	35.7	-	6.4	52.1	10.0	20.0	1.0
AMS3260LH	17.5	3.3	21.1	24.3	2.0	2.0	5.9	41.7	-	6.4	58.1	10.0	20.0	1.0
AMS3266LH	17.5	3.3	21.1	24.3	2.0	2.0	5.9	22.8	22.8	6.4	64.1	10.0	20.0	1.0
AMS3272LH	17.5	3.3	21.1	24.3	2.0	2.0	5.9	25.8	25.8	6.4	70.1	10.0	20.0	1.0
AMS3248RH	17.5	3.3	21.1	24.3	2.0	2.0	6.4	29.7	-	5.9	46.1	10.0	20.0	1.0
AMS3254RH	17.5	3.3	21.1	24.3	2.0	2.0	6.4	35.7	-	5.9	52.1	10.0	20.0	1.0
AMS3260RH	17.5	3.3	21.1	24.3	2.0	2.0	6.4	41.7	-	5.9	58.1	10.0	20.0	1.0
AMS3266RH	17.5	3.3	21.1	24.3	2.0	2.0	6.4	22.8	22.8	5.9	64.1	10.0	20.0	1.0
AMS3272RH	17.5	3.3	21.1	24.3	2.0	2.0	6.4	25.8	25.8	5.9	70.1	10.0	20.0	1.0
AMS2048US	24.7	3.3	21.1	24.3	2.0	2.0	5.9	30.3	-	5.9	46.1	2.9	20.0	1.0
AMS2054US	24.7	3.3	21.1	24.3	2.0	2.0	5.9	36.3	-	5.9	52.1	2.9	20.0	1.0
AMS2060US	24.7	3.3	21.1	24.3	2.0	2.0	5.9	42.3	-	5.9	58.1	2.9	20.0	1.0
AMS2066US	24.7	3.3	21.1	24.3	2.0	2.0	5.9	23.1	23.1	5.9	64.1	2.9	20.0	1.0
AMS2072US	24.7	3.3	21.1	24.3	2.0	2.0	5.9	26.1	26.1	5.9	70.1	2.9	20.0	1.0
AMS3248US	17.5	3.3	21.1	24.3	2.0	2.0	5.9	30.3	-	5.9	46.1	10.0	20.0	1.0
AMS3254US	17.5	3.3	21.1	24.3	2.0	2.0	5.9	36.3	-	5.9	52.1	10.0	20.0	1.0
AMS3260US	17.5	3.3	21.1	24.3	2.0	2.0	5.9	42.3	-	5.9	58.1	10.0	20.0	1.0
AMS3266US	17.5	3.3	21.1	24.3	2.0	2.0	5.9	23.1	23.1	5.9	64.1	10.0	20.0	1.0
AMS3272US	17.5	3.3	21.1	24.3	2.0	2.0	5.9	26.1	26.1	5.9	70.1	10.0	20.0	1.0
AMS2048SS	24.7	-	-	-	2.0	2.0	5.0	32.0	-	5.0	46.0	2.9	20.0	1.0
AMS2054SS	24.7	-	-	-	2.0	2.0	5.0	38.0	-	5.0	52.0	2.9	20.0	1.0
AMS2060SS	24.7	-	-	-	2.0	2.0	5.0	44.0	-	5.0	58.0	2.9	20.0	1.0
AMS2066SS	24.7	-	-	-	2.0	2.0	5.0	24.0	24.0	5.0	64.0	2.9	20.0	1.0
AMS2072SS	24.7	-	-	-	2.0	2.0	5.0	27.0	27.0	5.0	70.0	2.9	20.0	1.0
AMS3248SS	17.5	-	-	-	2.0	2.0	5.0	32.0	-	5.0	46.0	10.0	20.0	1.0
AMS3254SS	17.5	-	-	-	2.0	2.0	5.0	38.0	-	5.0	52.0	10.0	20.0	1.0
AMS3260SS	17.5	-	-	-	2.0	2.0	5.0	44.0	-	5.0	58.0	10.0	20.0	1.0
AMS3266SS	17.5	-	-	-	2.0	2.0	5.0	24.0	24.0	5.0	64.0	10.0	20.0	1.0
AMS3272SS	17.5	-	-	-	2.0	2.0	5.0	27.0	27.0	5.0	70.0	10.0	20.0	1.0

ALTITUDE

Altitude — Metal Screens (page 432)

- Powder coated magnetic metal privacy screen.
- Metal surfaces can be easily disinfected with cleaners. See cleaning guide for more details at AllsteelOffice.com.
- Available in all standard paint colors.
- Provides 1" gap along the back for accessory mount and cord drop.
- Available in 48"W, 54"W, 60"W, 66"W and 72"W.
- 66"W and 72"W screens include 3rd center bracket.
- Available in Straight, L- and U-shape configurations. Above and Above/Below desk applications.
- L- and U-Shape screens are not compatible with shrouded Height Adjustable Table legs.
- Optional tackable accessories specified separately.
- 66"W tackable accessory comes as a set of (2) 24"W.
- 72"W tackable accessory comes as a set of (2) 20"W.
- Available in standard and extended wings.
- Wings mount flush to the edge of the surface with an L-Bracket.
- 20"W tackable accessory must only be applied to both standard and extended wings without accessory slots.
- Wings are available with accessory slots that accept Radii Hot File, Side Saddle and Coat hook.
- Top slot can accept one Radii accessory.
- Bottom slot can accept a Coat hook and one other accessory.
- Accessories can hang on either side of the wing.
- TIP: If the Hot File is used in the top slot, it will block access for accessories in the bottom slot.
- Do not hang more than 5lbs of weight on wings.
- Screens are compatible with Radii undermount storage.
- Not compatible with standard 120-worksurfaces. Contact Allsteel TPG for custom sizes.
- When using a 24"D worksurface with Altitude screens, you must specify a T-foot.

Size Reference Matrix

Tackboards	Wing	48"W	54"W	60"W	66"W	72"W
Actual Dimensions	20"W	30"W	36"W	42"W	20"W	24"W
Set of Tackboards	1	1	1	1	2	2

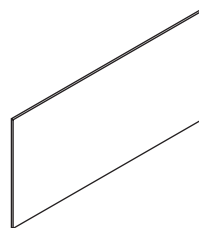

Accessories — Tackboard (page 433)

- Tackable accessories come with metal frame available in standard paint colors and fabric options.
- Attach to the screen using a dual lock tape (included in hardware).

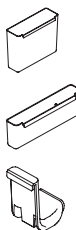

Accessories — Radii (page 433)

- Wings are available with accessory slots that accept Radii Hot File, Side Saddle and Coat hook.
- Top slot can accept one Radii accessory.
- Bottom slot can accept a Coat hook and one other accessory.
- Accessories can hang on either side of the wing.
- TIP: If the Hot File is used in the top slot, it will block access for accessories in the bottom slot.

Accessories — Further Worksurface Rail Mount (page 438)

- Accessory rail must be field cut to fit between the screen brackets.
- The following accessories are not compatible with screens: U9WTC and U9TM.

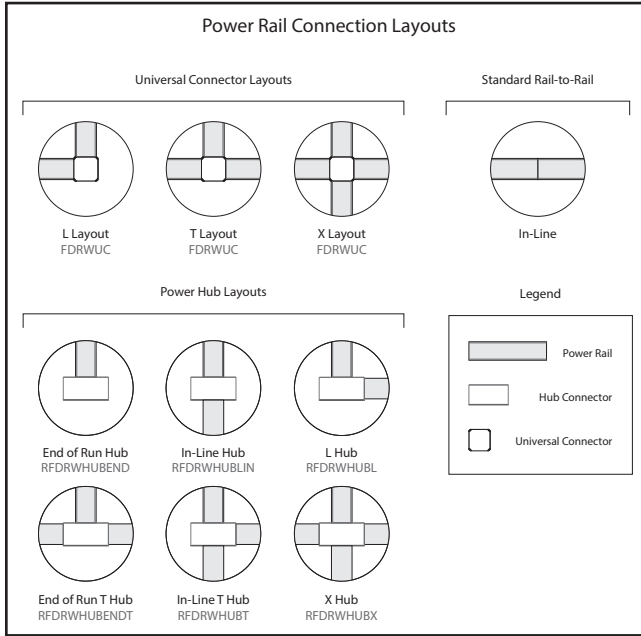

GENERAL OVERVIEW

- Accommodates power and lay-in capacity for data cables.
- Available in 48", 54", 60", 66", and 72" lengths.
- Maximum of 2 duplexes and 2 data ports per side of rail.
- Models come equipped with hardware for in-line connections.
- Fiber optic cables can follow 90 degree turns at the intersection of the power rails.
- Power harnesses snap into electrical brackets within the power rail and accept duplex receptacles.
- Electrical power harness accepts up to 2 duplex receptacles per side of rail.
- End caps are required at an end-of-run, unless connected to an end-of-run power pole or a hub.
- Power rail can be set low to the floor using the floor legs or raised off the floor at 20½" H with elevated legs.

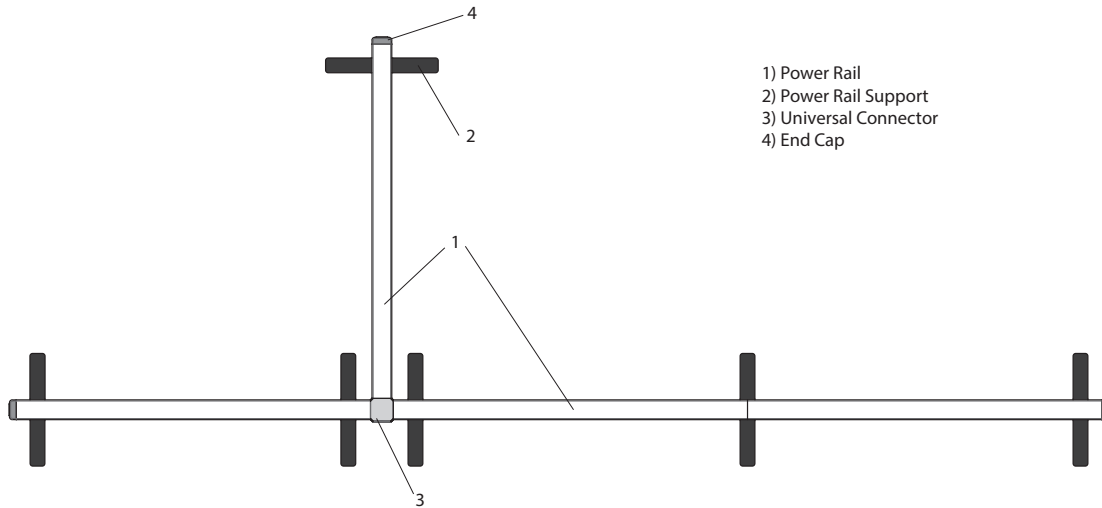

- 1) Power Rail
- 2) Power Rail Support
- 3) Universal Connector
- 4) End Cap

Power Rail Typicals

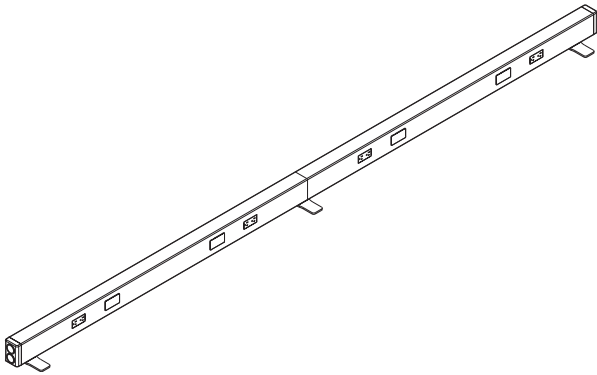

Low Rail, (2) 60"W Rail
Linear Configuration

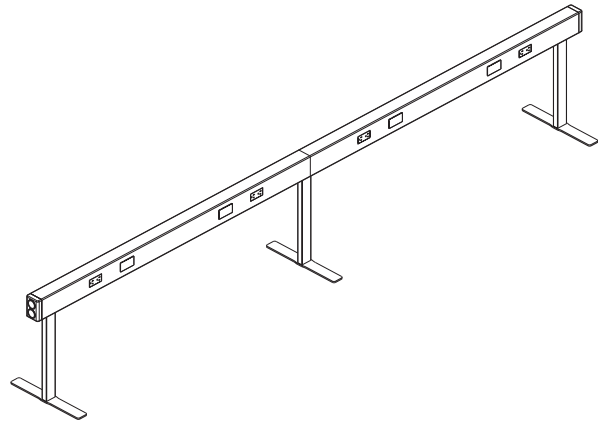

Raised Rail, (2) 60"W Rail
Linear Configuration

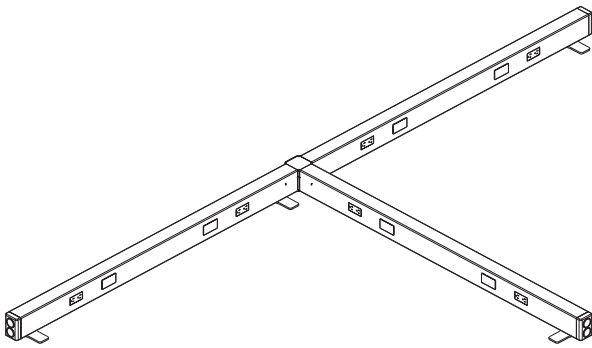

Low Rail, (3) 60"W Rail
T-Configuration

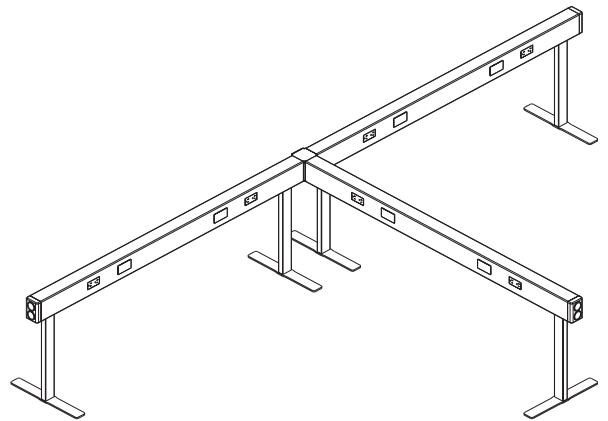

Raised Rail, (3) 60"W Rail
T-Configuration

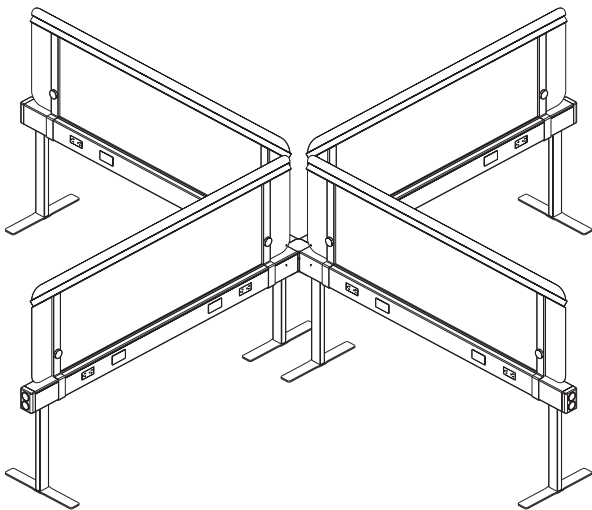

Raised Rail, (4) 60"W Rail
X-Configuration with Screens

ALTITUDE

WORKING WITH ALTITUDE POWER RAILS

Low Rail with Floor Legs:

- Each power rail is supported by (2) floor legs.
- Floor legs have a leveling mechanism that can adjust up to 1¼"H.
- Legs are specified separately and come in qty of 1. Each leg is 7¼"D x 2¼"W.
- Leg is inset 2.8" from end of the power rail.
- Universal connector allows "L", "T" and "X" configurations.
- Can connect directly to another power rail in linear applications without use of the universal connector.
- Cannot mount screens on the low rail.
- Power infeed can access the power rail in multiple ways:
 - through a receptacle position on the power rail (side infeed).
 - through the end cap on to the first power block.
 - through power pole using a power pole connector kit.

Raised Rail

- Power rails can be raised up to 20½"H using Elevated Legs and/or Hubs.
- Elevated Legs and Hubs can be used in conjunction to create the desired capability and aesthetic.
- Can be in Linear, L-, T- or X-configurations using Elevated Legs, Hubs or Universal Connector.
- Supports screens. See screens section for more details.
- Elevated Legs
 - Inset 2.8" from end of the power rail.
 - Can be shared in between the two rails in linear configuration.
 - Cannot route power and/or data.
 - Specified separately and come in qty of 1. Foot is included.
 - Leg is 15¼"D x 2¼"W x 17¾"H.
 - Order RFDRAWAB separately to anchor to floor. Appropriate fasteners per floor type sourced locally.
- Support Hubs
 - Connect directly to the power rail.
 - Can be shared in between the two rails.
 - L-, T- and X-hubs can be shared in between power rails.
 - End of Run hub is only specified at end condition.
 - Can route power and/or data.
 - Can integrate power pole. Power Pole connector kit is specified separately and come in qty of 1. Foot is included.

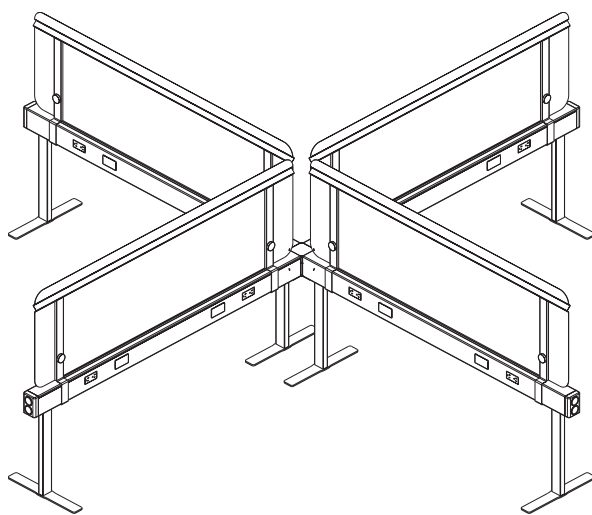

Screens

- Constructed of painted steel material.
- Standard Allsteel paint options can be applied.
- Screen height is 20"H, provides overall height of 42"H above fixed floor.
- Painted steel is magnetic and cleanable. Refer to cleaning solutions page at Allsteel Office website.
- Attachment hardware included.

ALTITUDE

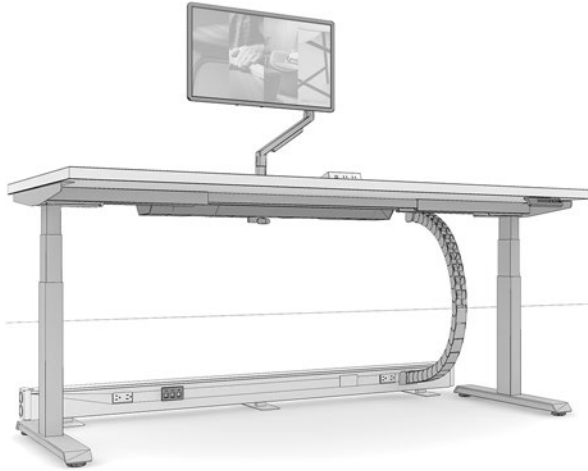

Altitude Desk + 60"W Low Rail + WKSVMC

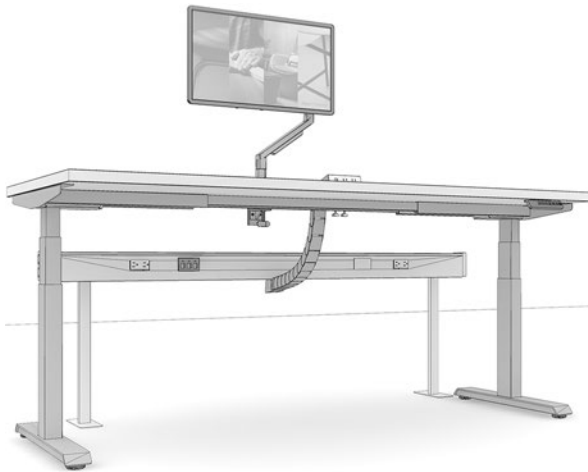

Altitude Desk + 60"W Raised Rail + A9CLWMC

WORKING WITH CABLE MANAGEMENT

- Used to route and conceal power/data cables from control box and other devices. Includes all mounting hardware.
- Houses 6 cables @ 0.300" diameter.
- Specify WKSVMC for 58" chain. Only comes in Black Finish. Recommended for use with Low Rail.
- Specify A9CLWMC for 36" chain. Comes in Black, White and Silver. Recommended for use with Raised Rail.
- Links the power rail to a height adjustable desk.
- Has two connecting points: Top section connects underneath the Height Adjustable Desk and the bottom section connects underneath the power rail using a double-sided tape. Hardware included.
- When mounting the chain to underneath the rail, an adapter link is required. Included in the hardware.

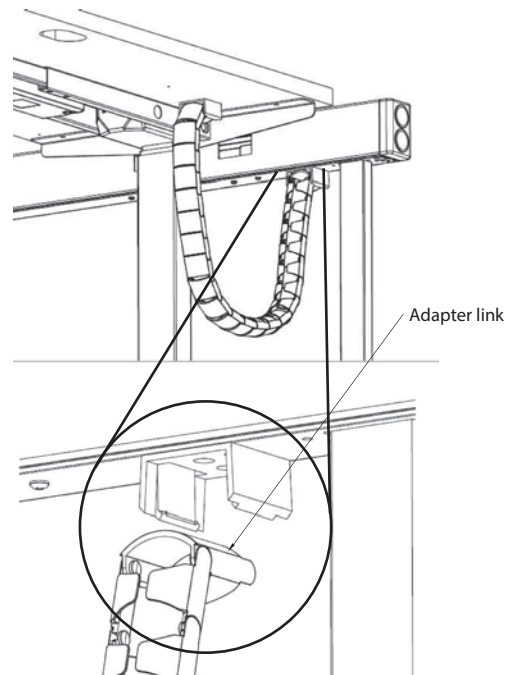

WORKING WITH POWER RAIL ELECTRICALS

General Notes about Electrical and Circuitry:

- Power Rail offers a choice of four electrical systems:
 - Four-circuit, 3 + 1
 - Four-circuit, 2 + 2
 - Three-circuit, separate neutrals
 - Eight circuits; two four-circuit systems provided back to back.
 - See Altitude Pricer section “Working with Electrical” for a detailed explanation of each electrical system.
 - All four systems utilize an 8-wire electrical system, rated at 20 amps.
- Per circuit (15 amps Canadian) — 16 amps plannable in U.S.
 - Power Rail and electrical components are UL Listed. Electrical
- Components are also CSA certified.
 - Installation and use of the electrical system, the number of receptacles.
- Used on a given circuit and connections to the building power supply.
- Should follow all local and national electrical codes.

Electrical Infeeds

- Power infeed cables deliver power from building to panel's electrical system.
- Infeed cables are housed in conduit to separate electrical system from communications and data lines.
- Select quantity of base or ceiling infeed cables depending on individual power requirements.
- Refer to rail supports for infeed access points.

Routing Power

- Power infeed can access the raised power rail in multiple ways:
 - Through power pole using a power pole connector kit.
 - Through Support Hubs.
 - Through the infeed vertebrae.

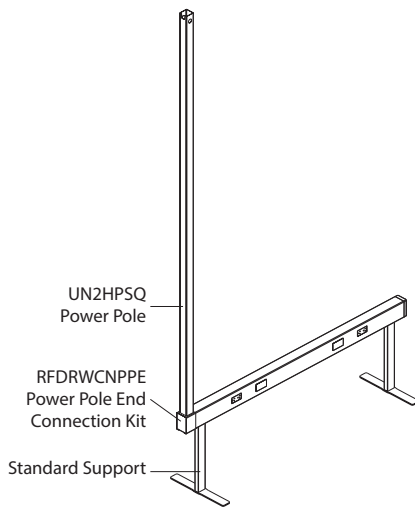
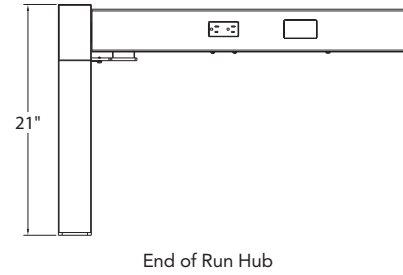
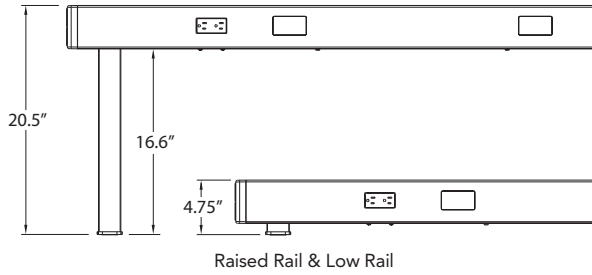

RFDRWCNPPE + UN2HPSQ
Connected to 60" W Rail

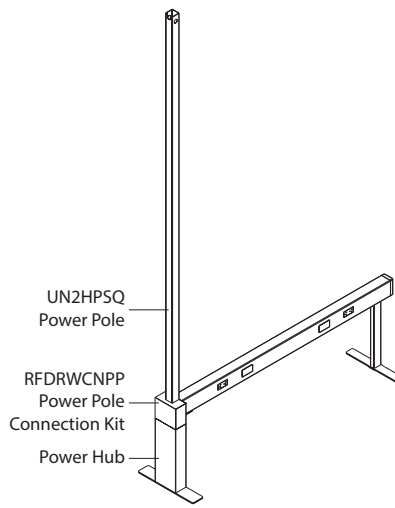

RFDRWHUBEND + RFDRWCNPP
UN2HPSQ connected to 60" W Rail

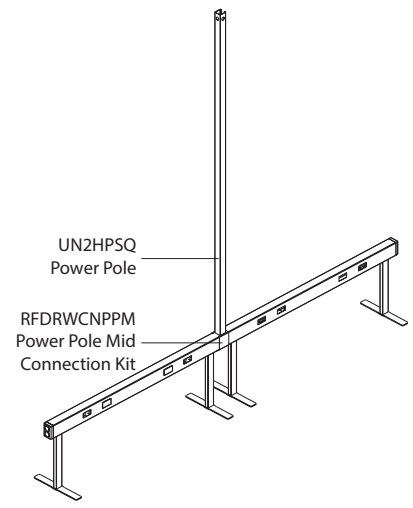

UN2HPSQ + RFDRWCNPPM
Connected to 60" W Rail

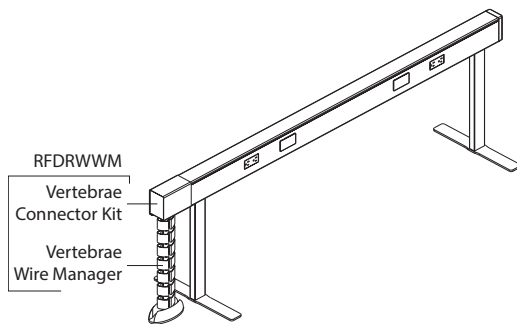

RFDRWWM
Connected to 60" W Rail

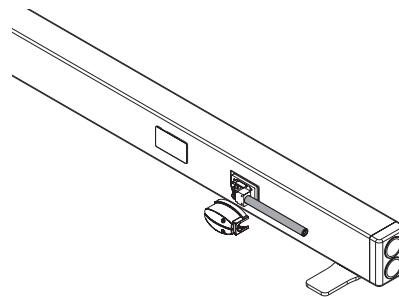

A876072 Infeed
Connected to 60" W Rail through
Receptacle Knockout

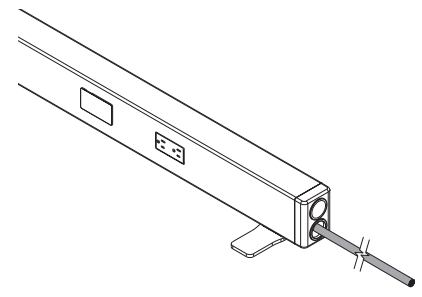

A877012 Infeed
Connected to 60" W Rail through End Cap

Electrical Systems

General Notes about Electric, Circuitry, and Chicago Code:

- Power Rail offers a choice of four electrical systems:
 - Four-circuit, 3 + 1
 - Four-circuit, 2 + 2
 - Three-circuit, separate neutrals
 - Eight circuits; two four-circuit systems provided back to back.
- See pages 416-417 for a detailed explanation of each electrical system.
- All four systems utilize an 8-wire electrical system, rated at 20 amps per circuit (15 amps Canadian) — 16 amps plannable in U.S.
- Power Rail and electrical components are UL Listed. Electrical components are also CSA certified.
- Installation and use of the electrical system, the number of receptacles used on a given circuit and connections to the building power supply should be in compliance with all local and national electrical codes.

Caution: Electrical equipment cords or extension cords MUST NOT BE ROUTED through cable openings in frame sides.

Note: No more than one conduit that is connected to a harness mounted to horizontal can be routed through the same cut out in the same horizontal at beltline. Attempting to use more will cause binding of conduit and may affect reveals on receptacles.

Hardwire New York Code (page 429)

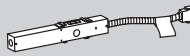
- Hardwire (New York Code) junction box (model A871400) is used when local electrical codes require hardwire entry. 
- For use in panels 48" W to 72" W.
- Unit must connect to a power harness.
- Customer to furnish all cabling and wiring from power entry to power source.
- Junction box can be positioned at any duplex receptacle location.
- For NY infeed through the end cap:
 - Order 24" pass-thru harness with power block A871124.
 - Will not have power at first cut-out from infeed.
- For NY infeed through a power rail cut-out:
 - Order 48"-72" pass-thru harness with power block. *Harness width must match power rail width.*
 - Will not have power at cut-out location used for infeed.
- For any power rail not used for infeed, order standard electrical power harness.

Hardwire Chicago Code (page 430)

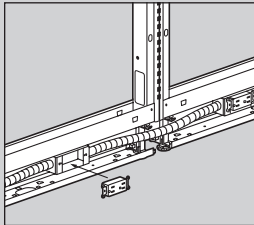
- Wiring harnesses and snap connectors are not allowed in Chicago — base pathways must be comprised of all-metallic components.
- The base pathway, junction box (model 873600) clips directly into receptacle locations and can be used both single- and double-sided.
- Customer must furnish conduit, wiring, and designer-type receptacles for the base pathway and conduit, wiring, designer-type receptacles, and receptacle covers for the beltline.
- Power entry can be routed from the floor into a junction box (model 873600). 

Electrical Infeeds

- Power infeed cables deliver power from building to panel's electrical system.
- Infeed cables are housed in conduit to separate electrical system from communications and data lines.
- Select quantity of base or ceiling infeed cables depending on individual power requirements.

Base Infeed (page 429)

- Sealtight base pathway power infeed mounts into any receptacle position in the base pathway area.
- A heavy rubber sheathing shields conduit, allowing infeed to be exposed.
- A jumper is required to connect base pathway power to beltline.

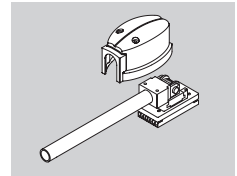

Sealtight Electrical Infeed (page 429)

- Sealtight electrical infeed cable is used with footed panels.
- Should not be ordered prior to installation to have pre-wired as infeed must be routed from inside of panel out to be connected to power.
- Cannot be connected to power harness in panel frame that infeed is brought into unless additional pass-thru harness without power block is used to feed from below beltline to above beltline.

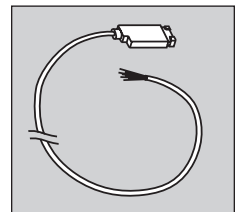

Power Infeed (page 429)

- Power infeed connects to a prewired electrical harness in the power rail.
- Most codes allow flex conduit to be exposed after installation. Verify code requirements before ordering for exposed application.

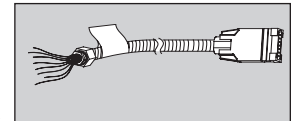

To Order:

- Determine which electrical system you will use after consulting your electrician and computer support personnel:
 - The Four-circuit system (4-Hot/2-Neutral/2-Ground)
 - 3 + 1 option
 - 2 + 2 option
 - The three-circuit system (3-Hot/3-Neutral/2-Ground)
 - The eight-circuit system (back-to-back four-circuit systems)
- Determine location, quantity, and circuit of duplexes.
- Determine the appropriate choice and use of isolated, isolated/dedicated, and separate neutrals circuits.
- Specify appropriate power harnesses* and pass-thru cables.*
- Determine the location, quantity, and type of power infeed needed.

* Select power harness models (A8712XX), with the last two digits corresponding with the panel width into which the component is to be positioned.
The initial cable length can be stretched approximately 3" to transverse "T", "X", "L", and extended straight connectors.

Flexconnect™ Electrical System Options

The four-circuit, eight-wire electrical system is widely specified and trusted by hundreds of thousands of end-users. This proven system delivers four circuits for every power infeed in either a 3 + 1 or 2 + 2 configuration. The isolated/dedicated circuits are ideal for sensitive computing equipment, while the common circuits are suitable for faxes, copiers, task lights and other peripherals. Both the 3 + 1 and 2 + 2 systems use the same pre-wired components, making it easy to adjust as electrical needs change.

You can also choose a three-circuit, eight-wire system that has a dedicated neutral for every hot circuit. The three-circuit components have model numbers with an "A" suffix and appear in a gray box in this price.

All three systems utilize an eight-wire electrical system rated at 20 amps per circuit (15 amps Canadian). Concensys panels and electrical components are UL listed and CSA certified.

Four-circuit, 3 + 1 Receptacle Option

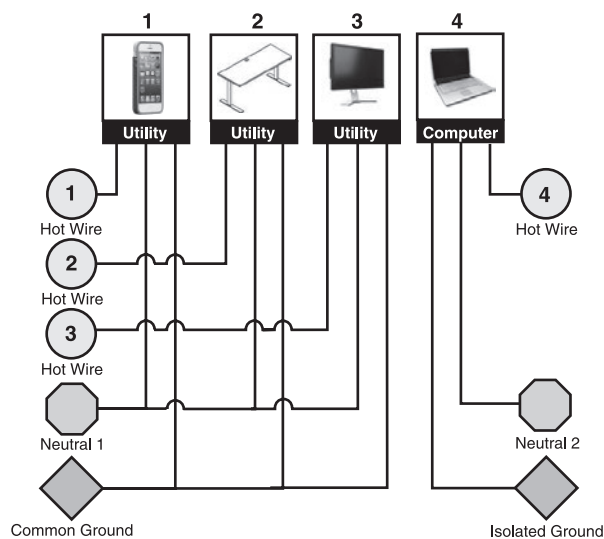

The 3 + 1 option is the electrical standard used on Allsteel systems for many years in most installations. This wiring option provides three utility circuits plus an isolated/dedicated circuit for more sensitive equipment. Circuit 2 (one of the 3 common circuits sharing a neutral wire) cannot be used with single-phase building electrical supply.

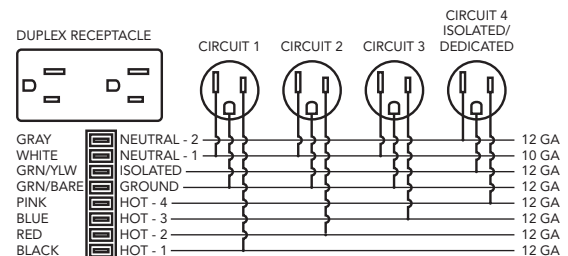

Four-circuit, 2 + 2 Receptacle Option

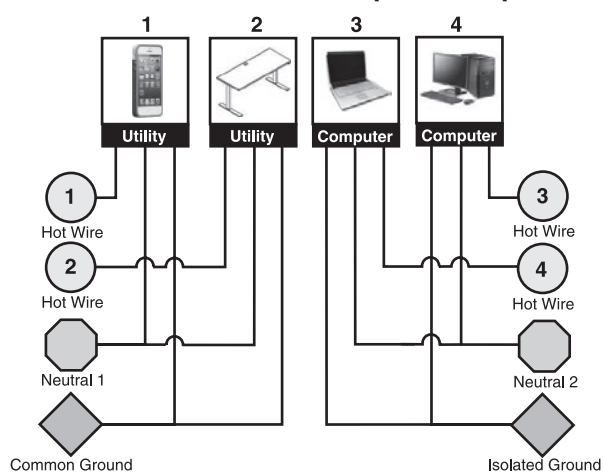

The 2 + 2 option is a wiring option that provides two utility circuits and two isolated circuits for more extensive computer usage applications.

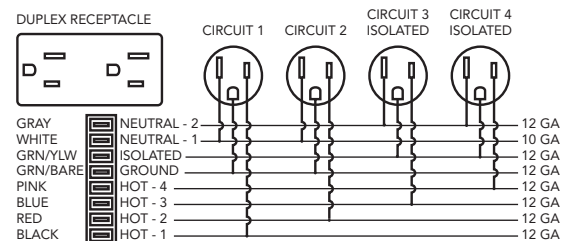

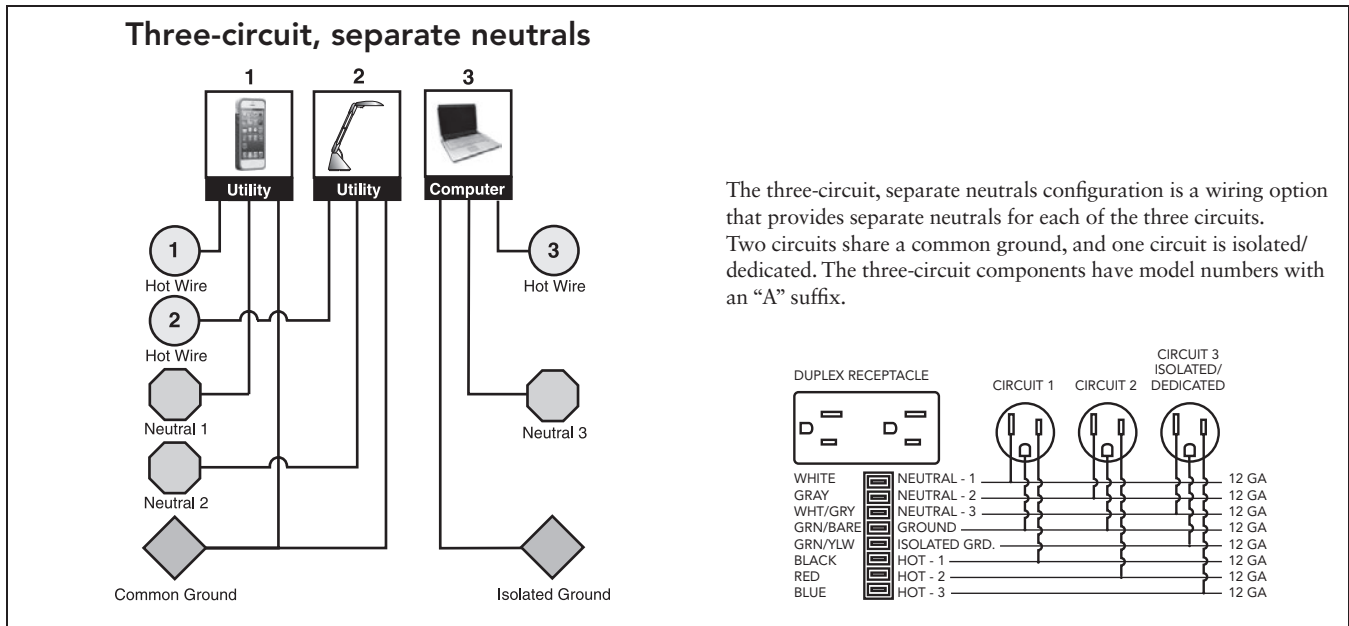

Altitude System Receptacle Usage					
Two 8-wire, 20 amp (15 amp Canadian) electrical systems are offered					
Electrical System	Circuitry	Receptacle Capacity			
Four-circuit 4-Hot/2-Neutral/2-Ground	3 + 1	Common Circuit-1 A873501	Common Circuit-2 ⁽¹⁾ A873502	Common Circuit-3 A873503	Iso/Dedicated Circuit-4 A873504
	2 + 2	Common Circuit-1 A873501	Common Circuit-2 A873502	Isolated Circuit-3 A873506	Isolated Circuit-4 A873504
Three-circuit 3-Hot/3-Neutral/2-Ground	w/separate neutrals	Common Circuit-1 A871501A	Common Circuit-2 A871502A	Iso/Dedicated Circuit-3 A871503A	N/A

(1) Circuit 2 (one of the 3 common circuits sharing a neutral wire) cannot be used with a single-phase building electrical supply.

Notes:

- Four-circuit components and three-circuit components (with suffix "A") cannot be used together.
- Components of the two systems are keyed differently to prevent components of one system being connected to components of another system.
- Allsteel model numbers are printed on the UL labels, and components are color-coded to provide visual identification of the different components.
- Four-circuit components have black plastic parts.
- Three-circuit components have rust-colored terminal ends and receptacle backs are rust-colored.

Duplex Receptacle



15 amp receptacle

ALTITUDE

Infeeds

- Power infeed cables deliver power from building to Power Rail's electrical system.
- Infeed cables are housed in conduit to separate electrical system from communications and data lines.
- Select quantity of infeed cables depending on individual power requirements.

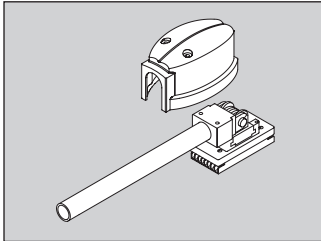

Base Infeed:

- Sealtight base pathway power infeed mounts into any receptacle position in the power rail housing.
- A heavy rubber sheathing shields conduit, allowing infeed to be exposed.

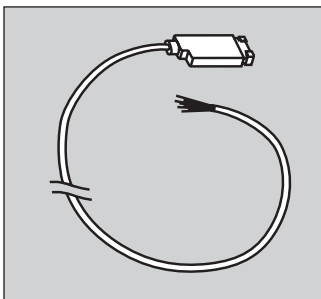

Sealtight Electrical Infeed:

- Sealtight electrical infeed is used for power entering through the end cap.
- Should not be ordered prior to installation to have pre-wired as infeed must be routed from inside of the power rail out to be connected to power.

Power Harness

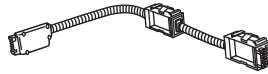

Electrical power harnesses are used to distribute power in the power rail. **Power blocks** on electrical power harness accept duplex receptacles.

- Electrical power harnesses are used to distribute power in Power Rails. Harnesses must be installed in each power rail housing.
- Specify harness length to match rail housing length. Each power harness accepts four duplex receptacles (two on each side of power rail housing).
- Connectors at both ends of power harnesses allow power distribution in either direction.
- Harness power blocks snap directly onto brackets in power rail housing.

Power Blocks

- Power blocks snap directly onto brackets in the power rail and accept receptacles (sold separately) on each side of harness.

Duplexes

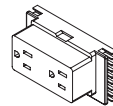

Duplex Receptacles

Receptacle Color Recommended to Coordinate with Paint Color

Paint Color	Receptacle Color
Bungalow — P7C	Muslin — EU
Champagne Metallic — PR5	Muslin — EU
Cinder — P7Q	Brownstone — EY
Fossil — P28	Flint — E9
Gunmetal Metallic — PR3	Brownstone — EY
Parchment — P93	Muslin — EU
Pebble — P8R	Loft — EV
Pewter — P8D	Flint — E9
Platinum — PR2	Loft — EV
Platinum Metallic — P42	Silver — E5
Salt — P8C	Silver — E5
Titanium — P8T	Silver — E5

- Duplex receptacles snap into power blocks of power harnesses.
- Duplexes are available in multiple colors. See inside front cover for finishes.
- Each receptacle is labeled to indicate which circuit it will be connected to: 1, 2, 3 or 4.
- Duplexes are model specific to support either 3 + 1 and 2 + 2 electrical infeed; or have an "A" suffix and are designed to support a three-circuit separate neutral electrical infeed.
- At least one duplex must be installed in upper housing side of rail housing assembly (see page 420, "Working with Electrical and Data").

Data

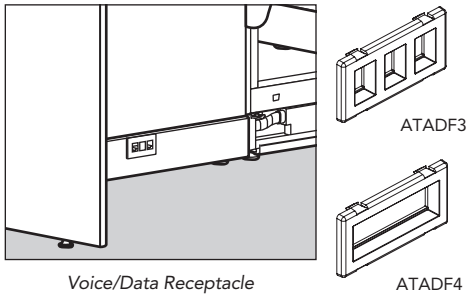

Voice/Data Receptacle

Data Faceplates:

- Fit into data port openings in Power Rail Housing.
- Due to rail housing depth, data modules should not be used back-to-back.

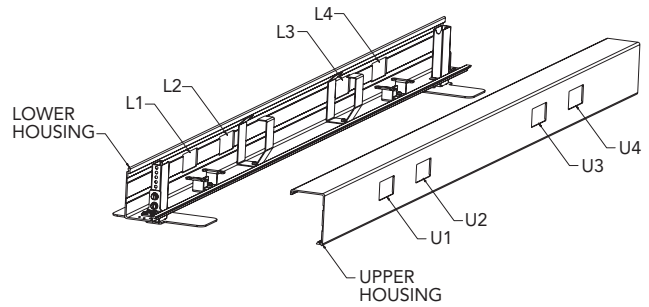

- Ports 1 and 4 accept duplexes, port covers and base infeeds.
- Ports 2 and 3 accept data and port covers.
- Either U1 or U4 must always contain a duplex.
- Data cannot be back-to-back (data in L2 + U2 or L3 + U3 combinations are not permitted).

Port Cover

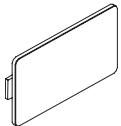

- Port covers must be used where no duplex or data faceplate is present.
- Fits into Power Rail port locations in place of duplex receptacles and data faceplates.
- Does not fit into port sizes of other product lines.

Cable Capacity

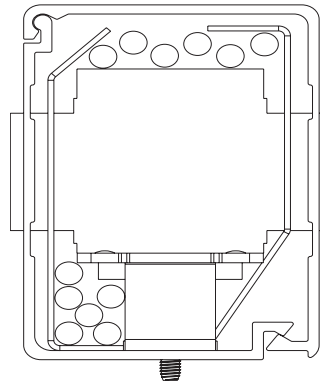

- The power rail housing allows continuous voice and data lines to run without interruption.
- Lay-in is provided for environments where systems furniture or cabling are subject to frequent change.
- Lower cavity allows 6 voice/data cables (1/4" dia).
- Upper cavity lay-in allows 6 voice/data cables (1/4" dia).

Power Rail Receptacle Locations

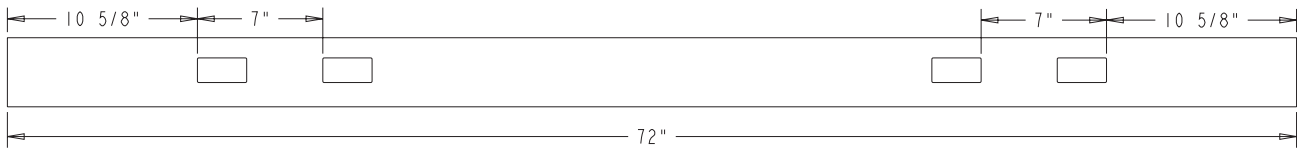
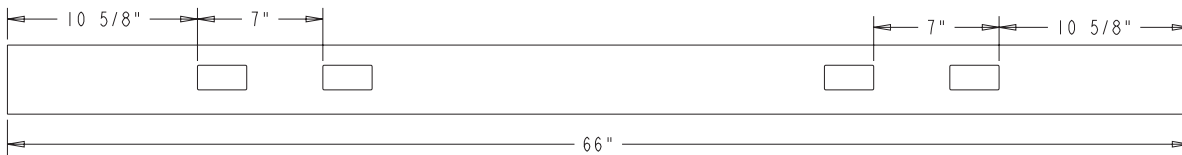
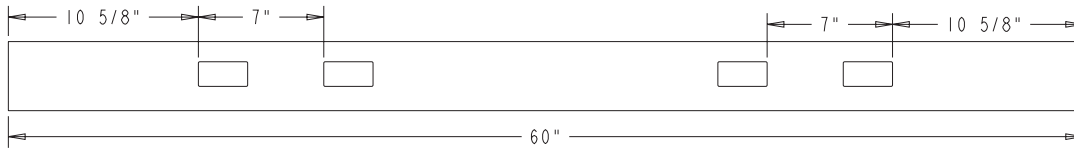
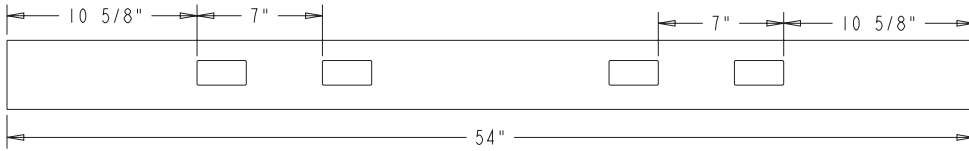
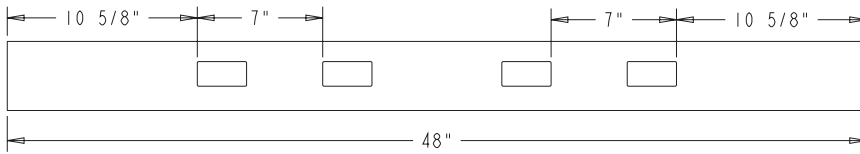

- For example, in a four-circuit system:
 - Circuit 1 — calculators, fans, etc.
 - Circuit 2 — task lights (could be wired to wall switch)
 - Circuit 3 — CRT or flat screen monitors
 - Circuit 4 — CPUs
- Use circuit 4 for power-sensitive electronic equipment.

Placement of pedestals and lateral files may render some duplex locations inaccessible. Pedestal placement may also affect compatibility with pull-up receptacles.

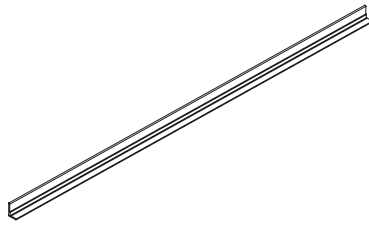

Rail Accessories

Side View

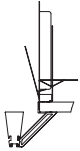

Top View

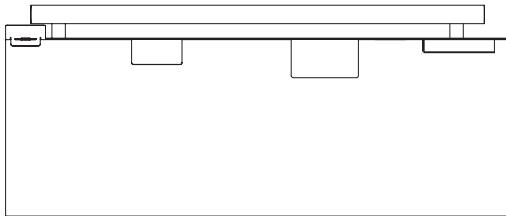

Phone/
Tablet
Stand

Pencil
Holder

Rail
Mounted
Shelf

Vertical
Paper Tray

Front View

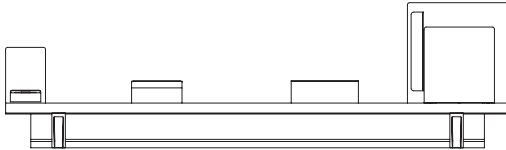

Worksurface Mounted Rail (page 438)

- Aluminum extrusion designed to mount to flat edge worksurfaces. Comes with rail and hardware for mounting.
- Mounted rail extends $\frac{3}{4}$ " on underside of worksurface which may interfere with the mounting of storage and screens.
- Widths available for Altitude tables 12" through 66" in 6" increments. Can pass across seams of ganged worksurfaces in tethered applications.
- Passes behind worksurface bracket on tethered applications.
- For freestanding applications rail should be 6" shorter than worksurface (i.e. 54" rail for 60" worksurface).

Rail Mounted Accessories

Not recommended for use on panel systems with attached worksurfaces due to fit up issues created with worksurface and panel. Adding accessory rail shifts worksurface — $\frac{3}{8}$ " away from panel along that edge. Forcing worksurface into place crushes fabric tile and with tiles of other material (steel, marker board, etc) is likely to scratch, dent, or otherwise damage tile during installation.

U9TM Phone/Tablet Stand (page 438)

- 6 $\frac{1}{2}$ "H x 4 $\frac{3}{4}$ "W and angles back 1 $\frac{1}{4}$ ".
- Has a $\frac{1}{4}$ " x 1" slot in bottom flange to allow for routing cables. Requires 1 $\frac{1}{4}$ " space behind worksurface edge in order to be used.



U9TP Pencil Holder (page 438)

- 2 $\frac{3}{8}$ "H x 6"W x 3"D.
- Holds approximately twenty #2 pencils.



U9TS Rail Mounted Shelf (page 438)

- 8"W x 4 $\frac{1}{2}$ "D and sits 2 $\frac{3}{8}$ " higher than top of worksurface.
- Holds up to 8 pounds.

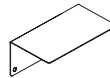

U9TF Vertical Paper Tray (page 438)

- Sits 12"H x 1 $\frac{1}{2}$ "W x 12"D from back of worksurface.
- Folder front stands 9" high from worksurface top, 1 $\frac{1}{4}$ " space holds about 280 sheets of copy paper.

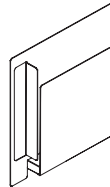

U9WTC Cord Organizer (page 438)

- Can attach to both bottom of worksurface or slides into rail.
- 4"W x 7 $\frac{1}{8}$ "D, made from sheet metal.
- Top sits flush with worksurface if mounted to worksurface.
- 4 cable cut outs: 2 – .250" diameter and 2 – 0.147" diameter; .250" diameter cut outs are centered between the .147" diameter cut outs.



Universal Hook (page 438)

- Mounts to underside of worksurface and provides storage for bags, coats and purses. Can be used as a horizontal wire manager.



For specification information see pages 401-402.

GSA SIN 33721

	Description	Model	List Price		
			P1	P2	P3
	2-Stage				
	2 Stage, 2 Leg Rectangle T Foot	A6REC2S2LTF	\$ 2151	\$ 2324	\$ 2582
	*Bases purchased in April 2021 or later accommodate 24"D-30"D Rectangular Worksurfaces 24"W-72"W, bases purchased prior to this date accommodate 24"D-30"D Rectangular Worksurfaces 48"W-72"W				
	2 Stage, 2 Leg Rectangle C Foot	A6REC2S2LCF	\$ 2151	\$ 2324	\$ 2582
	*Bases purchased in April 2021 or later accommodate 24"D-30"D Rectangular Worksurfaces 24"W-72"W, bases purchased prior to this date accommodate 24"D-30"D Rectangular Worksurfaces 48"W-72"W				
	3-Stage				
	A6 3 Stage, 2 Leg Rectangle T Foot	A6REC3S2LTF	\$ 2413	\$ 2607	\$ 2897
	*Bases purchased in April 2021 or later accommodate 24"D-30"D Rectangular Worksurfaces 24"W-72"W, bases purchased prior to this date accommodate 24"D-30"D Rectangular Worksurfaces 48"W-72"W				
	A6 3 Stage, 2 Leg Rectangle C Foot	A6REC3S2LCF	\$ 2413	\$ 2607	\$ 2897
	*Bases purchased in April 2021 or later accommodate 24"D-30"D Rectangular Worksurfaces 24"W-72"W, bases purchased prior to this date accommodate 24"D-30"D Rectangular Worksurfaces 48"W-72"W				
	A6 Max 3 Stage, 2 Leg T Foot	A6MREC3S2LTF	\$ 3349	\$ 3617	\$ 4020
	*Bases purchased in April 2021 or later accommodate 24"D-30"D Rectangular Worksurfaces 24"W-96"W, bases purchased prior to this date accommodate 24"D-30"D Rectangular Worksurfaces 48"W-96"W				
	*350 LB Max Lift Capacity				
	A6 Max 3 Stage, 2 Leg C Foot	A6MREC3S2LCF	\$ 3349	\$ 3617	\$ 4020
	*Bases purchased in April 2021 or later accommodate 24"D-30"D Rectangular Worksurfaces 24"W-96"W, bases purchased prior to this date accommodate 24"D-30"D Rectangular Worksurfaces 48"W-96"W				
	*350 LB Max Lift Capacity				

ALTITUDE

<p>How to specify — Select the Model Number from above.</p>	<p>1st Option: Select the Base Paint Color (if applicable): P1 P2 P3 See page 398 for paint finishes.</p>	<p>2nd Option: Select Feet Options (if applicable): X Standard Glides S Slide Glides (\$153 extra)</p>	<p>3rd Option: Select the Keypad (if applicable): UD Basic Up/Down MEM Memory Preset PDL Paddle</p>
_____.	_____.	_____.	_____.

Example: A6RND3S2LCF.P8L.X.PDL

For specification information see pages 401-402.

GSA SIN 33721

Description	Model	List Price		
		P1	P2	P3
2-Stage				
A6 2 Stage, 3 Leg Rectangle T Foot	A6REC2S3LTF	\$ 3480	\$ 3829	\$ 4351
A6 2 Stage, 3 Leg Rectangle C Foot	A6REC2S3LCF	\$ 3480	\$ 3829	\$ 4351
3-Stage				
A6 3 Stage, 3 Leg Rectangle T Foot	A6REC3S3LTF	\$ 3792	\$ 4096	\$ 4552
*3-leg standard bases can accommodate worksurface configurations from 24"D x 48"W x 36"W to 30"D x 72"W x 48"W.				
A6 3 Stage, 3 Leg Rectangle C Foot	A6REC3S3LCF	\$ 3792	\$ 4096	\$ 4552
*3-leg standard bases can accommodate worksurface configurations from 24"D x 48"W x 36"W to 30"D x 72"W x 48"W.				
A6 Max 3 Stage, 3 Leg Rectangle T Foot	A6MREC3S3LTF	\$ 4378	\$ 4817	\$ 5473
*3-Leg Max bases can accommodate worksurface configurations from 24"D x 48"W x 36"W to 30"D x 72"W x 72"W. *500 lb Max Lift Capacity				
A6 Max 3 Stage, 3 Leg Rectangle C Foot	A6MREC3S3LCF	\$ 4378	\$ 4817	\$ 5473
*3-Leg Max bases can accommodate worksurface configurations from 24"D x 48"W x 36"W to 30"D x 72"W x 72"W. *500 lb Max Lift Capacity				
Foot Retrofit Options				
Casters (Use on 2-leg bases ONLY)	A6CASTER*	\$ 277	N/A	N/A
* A6 casters are intended for use with Allsteel A6 height-adjustable tables. When purchased separately and used without Allsteel furniture, the A6 casters marked by (*) are considered Open Market.				
Slide Glides (Use on 2-leg bases ONLY)	A6SLDGLIDE	\$ 201	N/A	N/A
Bluetooth Control				
A6 Bluetooth Accessory	A6BLUETOOTH	\$ 142	N/A	N/A
* Bluetooth control will only work with 2-leg A6 tables. Bluetooth control will not work with 3-leg A6 tables.				

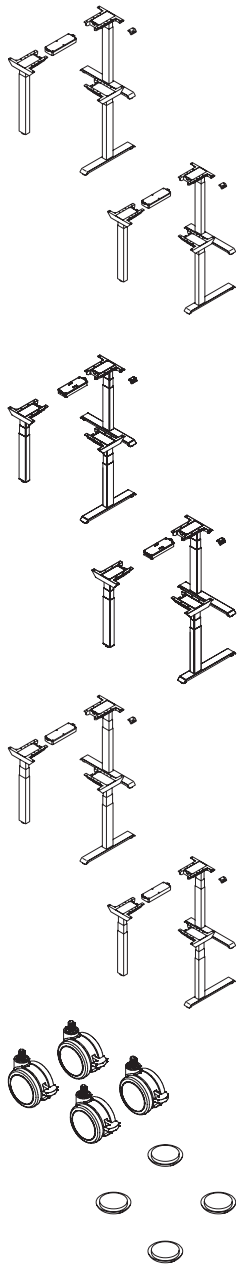

ALTITUDE

<p>How to specify — Select the Model Number from above.</p>	<p>1st Option: Select the Base Paint Color (if applicable): P1 P2 P3 See page 398 for paint finishes.</p>	<p>2nd Option: Select Feet Options (if applicable): X Standard Glides</p>	<p>3rd Option: Select the Keypad (if applicable): UD Basic Up/Down MEM Memory Preset PDL Paddle</p>
<p>_____ .</p>	<p>_____ .</p>	<p>_____ .</p>	<p>_____ .</p>

Example: A6RND3S3LCF.P8L.X.PDL

For specification information see page 402.

GSA SIN 33721

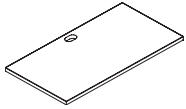

Description	Laminate w/Flat Edge Model	Veneer w/Square Edge Model	Ship Weight	List Price			List Price	
				L1	L2	L3	V2	V3
Rectangular Laminate Tops — 24"D (60" to 96" ships with stiffener)								
78"W – 96"W Tops can ONLY be used with Altitude MAX Base								
48"W	AF5RS4824	AVF5RS4824	46	\$ 626	\$ 651	\$ 671	\$ 2005	\$ 2187
54"W	AF5RS5424	AVF5RS5424	48	\$ 679	\$ 706	\$ 727	\$ 2100	\$ 2291
60"W	AF5RS6024D	AVF5RS6024D	53	\$ 845	\$ 873	\$ 895	\$ 2341	\$ 2554
66"W	AF5RS6624D	AVF5RS6624D	74	\$ 877	\$ 906	\$ 929	\$ 2347	\$ 2560
72"W	AF5RS7224D	AVF5RS7224D	82	\$ 901	\$ 930	\$ 953	\$ 2459	\$ 2682
78"W	AF5RS7824D		76	\$ 933	\$ 951	\$ 967	—	—
84"W	AF5RS8424D		81	\$ 839	\$ 857	\$ 873	—	—
90"W	AF5RS9024D		86	\$ 976	\$ 994	\$ 1010	—	—
96"W	AF5RS9624D		91	\$ 999	\$ 1017	\$ 1033	—	—

Rounded Corner Laminate Tops — 24"D (60" to 96" ships with stiffener)

78"W – 96"W Tops can ONLY be used with Altitude MAX Base

48"W	AF5RND4824		46	\$ 720	\$ 738	\$ 754	—	—
54"W	AF5RND5424		48	\$ 781	\$ 799	\$ 815	—	—
60"W	AF5RND6024D		53	\$ 953	\$ 971	\$ 987	—	—
66"W	AF5RND6624D		78	\$ 1003	\$ 1021	\$ 1037	—	—
72"W	AF5RND7224D		85	\$ 1035	\$ 1053	\$ 1069	—	—
78"W	AF5RND7824D		76	\$ 1070	\$ 1088	\$ 1104	—	—
84"W	AF5RND8424D		81	\$ 980	\$ 998	\$ 1014	—	—
90"W	AF5RND9024D		86	\$ 1121	\$ 1139	\$ 1155	—	—
96"W	AF5RND9624D		91	\$ 1146	\$ 1164	\$ 1180	—	—

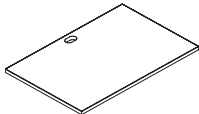

Rectangular Laminate Tops — 30"D (60" to 96" ships with stiffener)

78"W – 96"W Tops can ONLY be used with Altitude MAX Base

48"W	AF5RS4830	AVF5RS4830	52	\$ 704	\$ 731	\$ 753	\$ 2204	\$ 2404
54"W	AF5RS5430	AVF5RS5430	59	\$ 798	\$ 827	\$ 853	\$ 2302	\$ 2511
60"W	AF5RS6030D	AVF5RS6030D	63	\$ 945	\$ 976	\$ 1000	\$ 2539	\$ 2770
66"W	AF5RS6630D	AVF5RS6630D	78	\$ 1002	\$ 1034	\$ 1060	\$ 2547	\$ 2778
72"W	AF5RS7230D	AVF5RS7230D	87	\$ 1028	\$ 1060	\$ 1087	\$ 2656	\$ 2897
78"W	AF5RS7830D		92	\$ 1062	\$ 1080	\$ 1096	—	—
84"W	AF5RS8430D		98	\$ 972	\$ 990	\$ 1006	—	—
90"W	AF5RS9030D		105	\$ 1114	\$ 1132	\$ 1148	—	—
96"W	AF5RS9630D		111	\$ 1142	\$ 1160	\$ 1176	—	—



Rounded Corner Laminate Tops — 30"D (60" to 96" ships with stiffener)

78"W – 96"W Tops can ONLY be used with Altitude MAX Base

48"W	AF5RND4830		52	\$ 808	\$ 826	\$ 842	—	—
54"W	AF5RND5430		59	\$ 916	\$ 934	\$ 950	—	—
60"W	AF5RND6030D		63	\$ 1071	\$ 1089	\$ 1105	—	—
66"W	AF5RND6630D		82	\$ 1130	\$ 1148	\$ 1164	—	—
72"W	AF5RND7230D		90	\$ 1181	\$ 1199	\$ 1215	—	—
78"W	AF5RND7830D		92	\$ 1219	\$ 1237	\$ 1253	—	—
84"W	AF5RND8430D		98	\$ 1136	\$ 1154	\$ 1170	—	—
90"W	AF5RND9030D		105	\$ 1281	\$ 1299	\$ 1315	—	—
96"W	AF5RND9630D		111	\$ 1313	\$ 1331	\$ 1347	—	—

Note: Height-adjustable worksurface dimensions are nominal. Actual widths are reduced by 2" (1" on each side, and worksurface depths are reduced by 3/4". Corner cove depth is nominal, actual is 1" less. This is to allow for pinch-points and unobstructed table movement.

How to specify — Select the Model Number from above.	1st Option: Laminate or Veneer Type and Finish (if applicable): See page 398 for finishes.	2nd Option: Paint (if applicable): See page 398 for finishes.	3rd Option: Laminate Edge Color (if applicable): See page 398 for finishes.	4th Option: Grommet Location (if applicable): GC Grommet Center GO No Grommet	5th Option: Grommet Type (if applicable): P Oval Plastic M Oval Metal S Square Metal (Add \$13 per grommet for metal.)	6th Option: Grommet Color (Metal only): EL Matte Silver Plastic grommet color determined by worksurface finish.
_____ . _____ . _____ . _____ . _____ . _____	_____ . _____ . _____ . _____ . _____ . _____	_____ . _____ . _____ . _____ . _____ . _____	_____ . _____ . _____ . _____ . _____ . _____	_____ . _____ . _____ . _____ . _____ . _____	_____ . _____ . _____ . _____ . _____ . _____	_____ . _____ . _____ . _____ . _____ . _____

Examples: AF5RS4824.LM14EW.GO AVF5RS4824.SC777.GC.SEL

ALTITUDE

For specification information see page 402.

GSA SIN PENDING

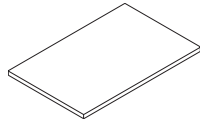

Description	Laminate w/Flat Edge Model	Ship Weight	List Price		
			L1	L2	L3
Undersized Rectangular Worksurface - 24"D (60" to 96" ships with stiffener)					
78"W - 96"W Tops can ONLY be used with Altitude MAX base.					
36"W	AF5RS3624U	23	\$ 511	\$ 536	\$ 560
42"W	AF5RS4224U	27	\$ 558	\$ 586	\$ 612
48"W	AF5RS4824U	31	\$ 626	\$ 657	\$ 686
54"W	AF5RS5424U	35	\$ 679	\$ 712	\$ 744
60"W	AF5RS6024UD	49	\$ 896	\$ 938	\$ 977
66"W	AF5RS6624UD	53	\$ 936	\$ 979	\$ 1020
72"W	AF5RS7224UD	57	\$ 966	\$ 1010	\$ 1052
78"W	AF5RS7824UD	62	\$ 1009	\$ 1054	\$ 1098
84"W	AF5RS8424UD	66	\$ 918	\$ 959	\$ 998
90"W	AF5RS9024UD	70	\$ 1066	\$ 1113	\$ 1159
96"W	AF5RS9624UD	74	\$ 1099	\$ 1147	\$ 1194

Undersized Rectangular Worksurface - 30"D (60" to 96" ships with stiffener)

78"W - 96"W Tops can ONLY be used with Altitude MAX base.

36"W	AF5RS3630U	29	\$ 568	\$ 596	\$ 623
42"W	AF5RS4230U	35	\$ 604	\$ 634	\$ 662
48"W	AF5RS4830U	40	\$ 704	\$ 738	\$ 771
54"W	AF5RS5430U	45	\$ 798	\$ 838	\$ 875
60"W	AF5RS6030UD	60	\$ 997	\$ 1043	\$ 1087
66"W	AF5RS6630UD	65	\$ 1062	\$ 1110	\$ 1157
72"W	AF5RS7230UD	70	\$ 1094	\$ 1143	\$ 1191
78"W	AF5RS7830UD	76	\$ 1137	\$ 1189	\$ 1238
84"W	AF5RS8430UD	81	\$ 1052	\$ 1099	\$ 1145
90"W	AF5RS9030UD	86	\$ 1205	\$ 1259	\$ 1312
96"W	AF5RS9630UD	91	\$ 1241	\$ 1296	\$ 1350

120 Degree Corner Worksurface - 24"D

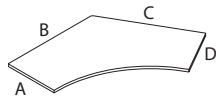

24" A x 42" B x 42" C x 24" D	AF5120S4224D	59	\$ 1073	\$ 1122	\$ 1170
24" A x 48" B x 48" C x 24" D	AF5120S4824D	69	\$ 1185	\$ 1239	\$ 1292
24" A x 54" B x 54" C x 24" D	AF5120S5424D	79	\$ 1400	\$ 1464	\$ 1525

120 Degree Corner Worksurface - 30"D

30" A x 42" B x 42" C x 30" D	AF5120S4230D	68	\$ 1073	\$ 1122	\$ 1170
30" A x 48" B x 48" C x 30" D	AF5120S4830D	79	\$ 1508	\$ 1578	\$ 1644
30" A x 54" B x 54" C x 30" D	AF5120S5430D	92	\$ 1723	\$ 1802	\$ 1879

Symmetrical Corner Cove Worksurface — 24"D

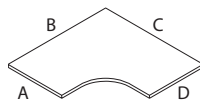

24" A x 54" B x 54" C x 24" D	AF5CCS5424	56	\$ 1190	\$ 1247	\$ 1303
-------------------------------	------------	----	---------	---------	---------

Symmetrical Corner Cove Worksurface — 30"D

30" A x 54" B x 54" C x 30" D	AF5CCS5430	66	\$ 1300	\$ 1362	\$ 1423
-------------------------------	------------	----	---------	---------	---------

ALTITUDE

How to specify — Select the Model Number from above.	1st Option: FSC Certified Wood:	2nd Option: Laminate:	3rd Option: Laminate Edge Color:	4th Option: Grommet Location (if applicable):	5th Option: Grommet Type (if applicable):	6th Option: Grommet Color (Metal only):
FSC FSC Mixed Credit X Standard Wood	See page 398 for finishes.	See page 398 for finishes.	GC Grommet Center GO No Grommet	P Oval Plastic M Oval Metal S Square Metal (Add \$13 per grommet for metal.)	EL Matte Silver Plastic grommet color determined by worksurface finish.	
_____ _____	_____	_____	_____	_____	_____	

Example:

For specification information see page 402.

GSA SIN 33721

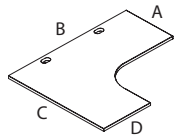

Description	Laminate w/Flat Edge Model	Ship Weight	List Price		
			L1	L2	L3
Corner Cove Laminate Tops — 24"D Extended Left					
24" A x 60" B x 36" C x 24" D	A5822ELS	54	\$ 1048	\$ 1084	\$ 1118
24" A x 60" B x 48" C x 24" D	A5622ELS	75	\$ 1148	\$ 1188	\$ 1225
24" A x 72" B x 36" C x 24" D	A5922ELS	63	\$ 1169	\$ 1209	\$ 1246
24" A x 72" B x 48" C x 24" D	A5722ELS	86	\$ 1462	\$ 1511	\$ 1557

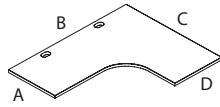

Corner Cove Laminate Tops — 24"D Extended Right					
24" A x 60" B x 36" C x 24" D	A5822ERS	54	\$ 1048	\$ 1084	\$ 1118
24" A x 60" B x 48" C x 24" D	A5622ERS	75	\$ 1148	\$ 1188	\$ 1225
24" A x 72" B x 36" C x 24" D	A5922ERS	63	\$ 1169	\$ 1209	\$ 1246
24" A x 72" B x 48" C x 24" D	A5722ERS	86	\$ 1462	\$ 1511	\$ 1557

Note: Height-adjustable worksurface dimensions are nominal. Actual widths are reduced by 2" (1" on each side" and worksurface depths are reduced by 3/4". Corner cove depth is nominal, actual is 1" less. This is to allow for pinch-points and unobstructed table movement.

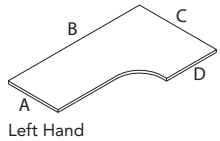

Undersized Corner Cove Worksurface, Left Hand — 24"D					
24" A x 60" B x 36" C x 24" D	AF5CCS603624LD	58	\$ 1098	\$ 1148	\$ 1197
24" A x 60" B x 48" C x 24" D	AF5CCS604824LD	67	\$ 1199	\$ 1254	\$ 1308
24" A x 72" B x 36" C x 24" D	AF5CCS723624LD	66	\$ 1236	\$ 1292	\$ 1347
24" A x 72" B x 48" C x 24" D	AF5CCS724824LD	75	\$ 1527	\$ 1597	\$ 1664

Left Hand

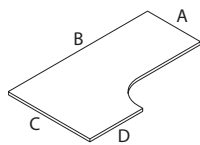

Undersized Corner Cove Worksurface, Right Hand — 24"D					
24" A x 60" B x 36" C x 24" D	AF5CCS603624RD	58	\$ 1098	\$ 1148	\$ 1197
24" A x 60" B x 48" C x 24" D	AF5CCS604824RD	67	\$ 1199	\$ 1254	\$ 1308
24" A x 72" B x 36" C x 24" D	AF5CCS723624RD	66	\$ 1236	\$ 1292	\$ 1347
24" A x 72" B x 48" C x 24" D	AF5CCS724824RD	75	\$ 1527	\$ 1597	\$ 1664

Right Hand

Undersized Corner Cove Worksurface, Left Hand — 30"D					
30" A x 60" B x 48" C x 30" D	AF5CCS604830LD	77	\$ 1282	\$ 1341	\$ 1399
30" A x 72" B x 48" C x 30" D	AF5CCS724830LD	88	\$ 1617	\$ 1691	\$ 1764

Undersized Corner Cove Worksurface, Right Hand — 30"D					
30" A x 60" B x 48" C x 30" D	AF5CCS604830RD	77	\$ 1282	\$ 1341	\$ 1399
30" A x 72" B x 48" C x 30" D	AF5CCS724830RD	88	\$ 1617	\$ 1691	\$ 1764

<p>How to specify — Select the Model Number from above.</p>	<p>1st Option: Laminate or Veneer Type and Finish (if applicable): See page 398 for finishes.</p>	<p>2nd Option: Paint (if applicable): See page 398 for finishes.</p>	<p>3rd Option: Laminate Edge Color (if applicable): See page 398 for finishes.</p>	<p>4th Option: Grommet Location and Type:</p> <p>GC Center P Oval Plastic M Oval Metal</p> <p>GB Grommet LH/RH P Oval Plastic M Oval Metal S Square Metal</p> <p>GO No Grommet</p>
<p>Examples:</p>				

For specification information see page 405.

GSA SIN 33721

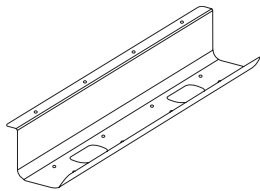

AJTRGH24

Description	Model	List Price		
		P1	P2	P3
Cable Management Trays				
24"W	AJTRGH24 S	\$ 123	N/A	N/A
36"W	AJTRGH36 S	\$ 147	N/A	N/A

- Available in 24" or 36" widths.
- Metal Cable Management Trays available in Black only, specify "P" for finish.
- Example: AJTRGH24.P

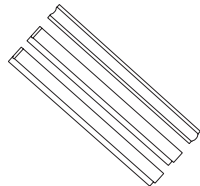

AWRSTRIP

Wire Management Strips/Channels				
	AWRSTRIP S	\$ 270	N/A	N/A

- Four wire management strips/channels in black only, no specification needed.
- Example: AWRSTRIP

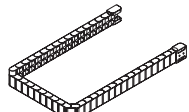

WKSWMC

Wire Management Chains				
36"	A9CLWMC S	\$ 357	N/A	N/A
58"	WKSWMC S	\$ 428	N/A	N/A

- Specify model A9CLWMC for 36" chain, specify model WKSWMC for 58" chain.
- A9CLWMC available in Black (E4), White (DW), or Silver (TI).
- WKSWMC available in Black only, no specification needed.
- Example: A9CLWMC.DW or WKSWMC

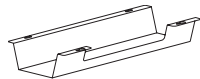

APWRTRGH17

Under Worksurface Troughs				
17"W	APWRTRGH17 S	\$ 108	N/A	N/A
36"W	APWRTRGH36 S	\$ 189	N/A	N/A

- Available in 17" or 36" widths.
- Under Worksurface Troughs available in Black only, no specification needed.
- Example: APWRTRGH17

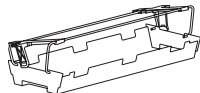

AFDTRGH20

Flip-Down Wire Management Trough				
20"W	AFDTRGH20 S	\$ 378	N/A	N/A
32"W	AFDTRGH32 S	\$ 429	N/A	N/A

- Available in 20" or 32" widths.
- Flip-Down Troughs available in Black only, specify "P" for Black.
- Example: AFTRGH20.P



AWIRECLT

Metal Wire Cleat				
	AWIRECLT S	\$ 129	\$ 142	\$ 148

- Available in standard metal paint finishes, see page 398 for options and specify desired finish.
- Example: AWIRECLT.PJW

<p>How to specify —</p> <p>Select the Model Number from above.</p>	<p>1st Option:</p> <p>Paint (if applicable): See page 398 for finishes.</p> <p>Plastics (if applicable):</p> <p>DW White TI Silver E4 Black</p>
---	---

Examples: AJTRGH24.P A9CLWMC.DW AWIRECLT.PR6

S Shippable by small-package carrier.

For specification information see page 405.1.

GSA SIN 33721

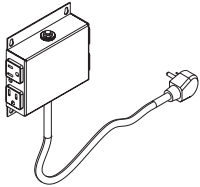

APWR4TAP

Description	Model	List Price
Power Module — Under Worksurface, Quad Tap		
7"W x 12"D x 3"H	APWR4TAP S	\$ 456

- 4 receptacles.
- 10' Straight cord only, no specification needed.
- Available in Black only, no specification needed.
- Example: APWR4TAP

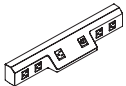

FDPWRC

Concealed Power Module		
Corded, 1 USB-A, 1 USB-C	FDPWRC S	\$ 766
Corded Chicago Code, 1 USB-A, 1 USB-C	CFDPWRC S	\$ 1306
Spiral Cord, 1 USB-A, 1 USB-C	FDPWRSC S	\$ 806
Spiral Cord Chicago Code, 1 USB-A, 1 USB-C	CFDPWRSC S	\$ 1338

- FDPWRC is plastic, straight cord unit with 4 receptacles, 1 USB-A and 1 USB-C port.
- CFDPWRC is metal, straight cord Chicago Code unit with 4 receptacles, 1 USB-A and 1 USB-C port.
- FDPWRSC is plastic, coiled cord unit with 4 receptacles, 1 USB-A and 1-USB-C port.
- CFDPWRSC is metal, coiled cord unit with 4 receptacles, 1 USB-A and 1 USB-C port.
- Available in Storm (STRM) only, specify Storm.
- Example: FDPWRC.STRM

<p>How to specify — Select the Model Number from above.</p> <div style="border-top: 1px solid black; border-bottom: 1px solid black; height: 20px; margin-top: 10px;"></div>	<p><i>1st Option:</i> Paint (if applicable): STRM Storm</p> <div style="border-top: 1px solid black; border-bottom: 1px solid black; height: 20px; margin-top: 10px;"></div>
---	--

Examples: APWR4TAP FDPWRC.STRM

S Shippable by small-package carrier.

For specification information see page 405.1.

GSA SIN 33721

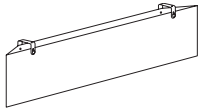

APWRMODEST36

Description	Model	List Price	
		A	B
Fabric Power Modesty			
	APWRMODEST36 [S]	\$ 1162	\$ 1196
	APWRMODEST48 [S]	\$ 1258	\$ 1297

- Available in Appoint, Binary, Centurion, Noble, Reflections, Disperse, and Spin panel fabric series.
- Specify desired fabric.
- Example: APWRMODEST36.NBLE16

<p>How to specify — Select the Model Number from above.</p> <p>_____ .</p>	<p>1st Option: Fabric (if applicable): See pages 17-19 for fabrics.</p> <p>_____</p>
---	--

Example: APWRMODEST36.NBLE16

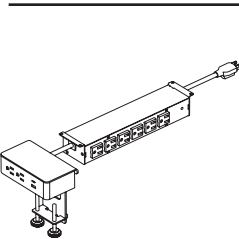

AABPWRMOD.AC.S

Description	Model	List Price
Power Module — Above/Below Worksurface 8¼"W x 16"D x 4½"H	AABPWRMOD [S]	\$ 1234

- Desktop unit includes 2 receptacles, 1 USB-A, & 1 USB-C (AC).
- Under worksurface unit include 6 receptacles.
- Power cord choices include a 6' Straight cord (S) or Coiled cord (Q).
- Desktop unit available in White (DWT) or Gray (DGY).
- Example: AABPWRMOD.AC.S.DWT

<p>How to specify — Select the Model Number from above.</p> <p>A A B P W R M O D .</p>	<p>1st Option: Ports (Final port option if applicable): AC USB-A+C</p> <p>A C .</p>	<p>2nd Option: Cord Type (Power Module cord type if applicable): S Straight Cord Q Coiled Cord</p> <p>. .</p>	<p>3rd Option: Color Option (if applicable): DWT White DGY Gray</p> <p>. . .</p>
---	---	---	--

Example: AABPWRMOD.AC.Q.DWT

[S] Shippable by small-package carrier.

For specification information see page 405.2.

GSA SIN 33721

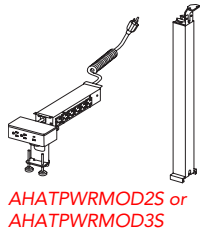

Description	Model	List Price		
		P1	P2	P3
Metal Telescoping HAT Wire Management				
	AHATPWRMOD2S	\$ 1614	\$ 1654	\$ 1675
	AHATPWRMOD3S	\$ 1646	\$ 1690	\$ 1711

- AHATPWRMOD2S pairs with 2-stage HAT bases.
- AHATPWRMOD3S pairs with 3-stage HAT bases.
- Desktop power module comes with 2 receptacles, 1 USB-A, and 1 USB-C port only, specify “AC” for this power configuration.
- Desktop power module available in White (DWT) or Gray (DGY) finishes, specify desired finish.
- Under worksurface power strip comes with 6 receptacles and is available in Black only, no specification needed.
- Metal Telescoping Chase available in the same paint finishes as Altitude HAT bases, specify desired paint finish.
- *Example: AHATPWRMOD2S.AC.DWT.PJW*

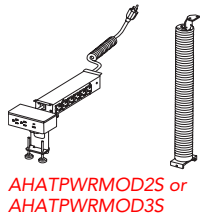

Description	Model	List Price		
		P1	P2	P3
Fabric HAT Wire Management				
	AHATPWRMODF	\$ 1476	\$ 1503	\$ 1516

- AHATPWRMODF pairs with 2-stage and 3-stage HAT bases.
- Desktop power module comes with 2 receptacles, 1 USB-A, and 1 USB-C port only, specify “AC” for this power configuration.
- Desktop power module available in White (DWT) or Gray (DGY) finishes, specify desired finish.
- Under worksurface power strip comes with 6 receptacles and is available in Black only, no specification needed.
- Fabric HAT Chase available in three fabric finishes of Light (LGT), Medium (MDD), and Dark (DRK), specify desired fabric finish.
- Fabric HAT mounting brackets available in the same paint finishes as Altitude HAT bases, specify desired paint finish.
- *Example: AHATPWRMODF.AC.DGY.LGT.PR5*

ALTITUDE

<p>How to specify — Select the Model Number from above.</p>	<p><i>1st Option:</i> Ports (Final port option if applicable): AC USB-A+C</p>	<p><i>2nd Option:</i> Power Module Color Option (if applicable): DWT White DGY Gray</p>	<p><i>3rd Option:</i> Fabric Chase Finish (if applicable): LGT Light MDD Medium DRK Dark</p>	<p><i>4th Option:</i> Metal Paint Option (if applicable): See page 398 for finishes.</p>
<p>AHATPWRMOD . AC . D . . </p>				

Example: AHATPWRMOD3S.AC.DWT.P8C AHATPWRMODF.AC.DGY.LGT.PR5

S Shippable by small-package carrier.

For specification information see page 418.

GSA SIN 33721

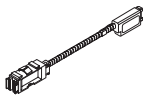
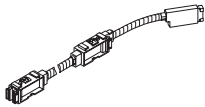

Description	Max. Recept. Cap. per Panel Side	Four-circuit 3 + 1 2 + 2	Three-circuit Separate Neutrals		List Price
Electrical Power Harnesses					
For 48" W Frames	2	A871248*	A871248A	<input type="checkbox"/>	\$ 416
For 54" W Frames	2	A871254*	A871254A	<input type="checkbox"/>	\$ 414
For 60" W Frames	2	A871260*	A871260A	<input type="checkbox"/>	\$ 416
For 66" W Frames	2	A871266*	A871266A	<input type="checkbox"/>	\$ 414
For 72" W Frames	2	A871272*	A871272A	<input type="checkbox"/>	\$ 417

Note: Four-circuit components and Three-circuit components (with an "A" suffix) cannot be connected together.

Electrical Pass-Thru Harnesses with Power Block

For 24" W Frames**	1	A871124	A871124A	<input type="checkbox"/>	\$ 239
For 48" W Frames†	1	A871148*†	A871148A	<input type="checkbox"/>	\$ 255
For 60" W Frames†	1	A871160*	A871160A	<input type="checkbox"/>	\$ 255
For 72" W Frames†	1	A871172	A871172A	<input type="checkbox"/>	\$ 341

Electrical harnesses are intended for use with Allsteel systems furniture and are approved under GSA SIN 33721. When purchased separately and used without Allsteel systems furniture, those electrical harnesses marked by () are considered Open Market.

**Only used with NY Infeed through End Cap.

†48"-72" are only used with NY infeed through power rail cut-out.

‡When purchased separately without a configurable TAA compliant end product, not on GSA contract.

<p>How to specify — Select the Model Number from above.</p> <p>_____ .</p>	<p><i>1st Option:</i> Color: P Black</p>
---	---

Examples: A871248.P A871224.P A871224A.P A871124.P

Shippable by small-package carrier.

For specification information see page 418.

GSA SIN 33721

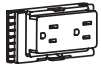

Duplex Receptacle

Description	Four-circuit 3 + 1 2 + 2	Three-circuit Separate Neutrals		List Price
Duplex Receptacles for Beltline or Base Pathway — Altitude (specify color)				
Circuit 1	A873501	A871501A	S	\$ 72
Circuit 2	A873502	A871502A	S	\$ 72
Circuit 3 (3+1)	A873503	A871503A	S	\$ 72
Circuit 3 (2+2)	A873506	N/A	S	\$ 72
Circuit 4 — iso/dedicated	A873504	N/A	S	\$ 72
Circuit 1, 20 AMP	A871601	A871601A	S	\$ 72

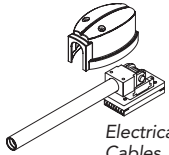

Electrical Infeed Cables

Electrical Infeed Cables				
6' Sealtight Cable for Terrace Receptacle	A876072	A8716072A	S	\$ 439
6' Flex Cable	A871972	A871972A	S	\$ 331

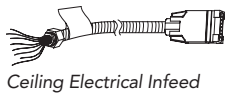

Ceiling Electrical Infeed

Ceiling Electrical Infeed Cables				
12' Flex Cable	A871912	A871912A	S	\$ 449
18' Flex Cable	A871918	A871918A	S	\$ 565

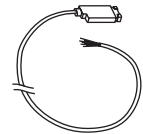

Electrical Infeed Cable

Electrical Infeed Cables (for use with footed panels)				
12' Sealtight Cable Power Infeed	A877012	N/A	S	\$ 547

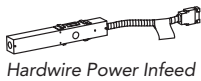

Hardwire Power Infeed

Hardwire Power Infeed (New York Code)				
For 48"-72" W rails	A871400	A871400A	S	\$ 431

Note: Four-circuit components and Three-circuit components (with an "A" suffix) cannot be connected together.

ALTITUDE

<p>How to specify — Select the Model Number from above.</p> <p>_____ .</p>	<p><i>1st Option:</i> Electrical Receptacle Color (if applicable): See page 398 for finishes.</p> <p>E S</p>
---	---

Example: A873501.E4

For specification information see page 418.

GSA SIN 33721



Description	Model	List Price
Hardwire (Chicago Code) (Black only)		
Altitude Base Pathway Junction Box (Pack of 6)	873600	\$ 1145

For specification information see page 419.

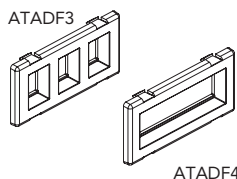

Description	Model	P1 Paint List Price
Data Faceplates		
Three-Port Flex-Mode Faceplate, Black (E4)	ATADF3	\$ 42
Four-Port Flex-Mode Faceplate, Black (E4)	ATADF4	\$ 42

Notes: ATADF3 can install up to 3 jacks (CAT 3, 5E, or 6). ATADF4 can install 4 jacks (CAT 3, 5E, or 6).
 ATADF models are compatible with ports in Altitude tiles.
 Allsteel's data faceplates are designed for use with the jacks listed below. We do not guarantee compatibility with other manufacturers' product.

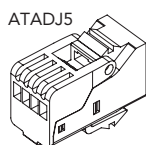

Jacks		
RJ45 CAT 5E Jack — Black only		
Toolless	ATADJ5	\$ 74
RJ45 CAT 6 Jack — Black only		
Requires Tool	ATADJ6	\$ 98

ALTITUDE

How to specify —
 Select the Model Number from above.

Example: 873600

How to specify —
 Select the Model Number from above.

1st Option:
Data Faceplate Color:
 E4 Black

A | T | A | D | . | E | 4 |

Example: ATADF4.E4

Shippable by small-package carrier.

For specification information see page 406.

Open Market

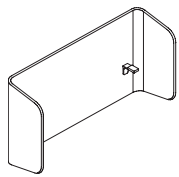

Description	Model	Old Model Numbers	Ship Weight	Cubes	List Price	
					A	D
U Screen Kit						
48"	FDSC48U	FDSCU48K	30.0	16.6	\$ 2032	\$ 2157
54"	FDSC54U	FDSCU54K	31.0	18.6	\$ 2102	\$ 2232
60"	FDSC60U (shown)	FDSCU60K	32.0	20.6	\$ 2163	\$ 2297
66"	FDSC66U	FDSCU66K	33.0	22.6	\$ 2290	\$ 2434
72"	FDSC72U	FDSCU72K	34.0	24.6	\$ 2463	\$ 2618

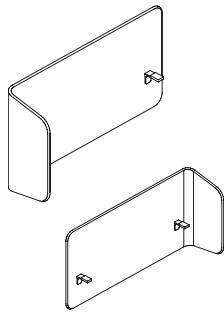

L Screen Kit						
Left Hand 48"	FDSC48LL	FDSC48LK	26.5	16.6	\$ 1322	\$ 1395
Right Hand 48"	FDSC48LR	FDSC48RK	26.5	16.6	\$ 1322	\$ 1395
Left Hand 54"	FDSC54LL	FDSC54LK	27.5	18.6	\$ 1549	\$ 1636
Right Hand 54"	FDSC54LR	FDSC54RK	27.5	18.6	\$ 1549	\$ 1636
Left Hand 60"	FDSC60LL (shown)	FDSC60LK	28.5	20.6	\$ 1619	\$ 1712
Right Hand 60"	FDSC60LR (shown)	FDSC60RK	28.5	20.6	\$ 1619	\$ 1712
Left Hand 66"	FDSC66LL	FDSC66LK	29.5	22.6	\$ 1928	\$ 2047
Right Hand 66"	FDSC66LR	FDSC66RK	29.5	22.6	\$ 1928	\$ 2047
Left Hand 72"	FDSC72LL	FDSC72LK	30.5	24.6	\$ 2030	\$ 2155
Right Hand 72"	FDSC72LR	FDSC72RK	30.5	24.6	\$ 2030	\$ 2155

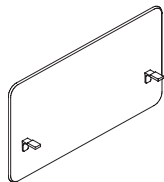

Rectangular Screen Kit						
48"	FDSC48R	FDSCR48K	23.0	3.7	\$ 1279	\$ 1350
54"	FDSC54R	FDSCR54K	24.0	4.1	\$ 1310	\$ 1383
60"	FDSC60R (shown)	FDSCR60K	25.0	4.6	\$ 1407	\$ 1486
66"	FDSC66R	FDSCR66K	26.0	5.0	\$ 1617	\$ 1714
72"	FDSC72R	FDSCR72K	27.0	5.6	\$ 1721	\$ 1826

Note: Installation brackets are now attached to the screen from the factory.

ALTITUDE

<p>How to specify — Select the Model Number from above.</p>	<p>1st Option: Select the Screen Fabric: See page 399 for selections and color codes.</p>	<p>2nd Option: Select the Screen Bracket Paint: P1 P2 See page 398 for selections and color codes.* P2 (\$16 extra)</p>
--	--	--

Examples: FDSCU48K.PCAMBLT40.P71 FDSC48LK.PCAMBLT70.P71 FDSCR48K.PCAMBLT39.P71

For specification information see pages 407-408.

GSA SIN 33721

		Description	Model	P1 Paint List Price	P2 Paint Upcharge	P3 Paint Upcharge
20"H Metal L-Screen						
		48"W	AMS2048LH	\$ 833	\$ 866	\$ 899
	Extended	54"W	AMS2054LH	\$ 906	\$ 942	\$ 978
		60"W	AMS2060LH	\$ 1014	\$ 1055	\$ 1094
		66"W	AMS2066LH	\$ 1109	\$ 1153	\$ 1196
		72"W	AMS2072LH	\$ 1160	\$ 1206	\$ 1251
	Extended Slots	48"W	AMS2048RH (shown)	\$ 833	\$ 866	\$ 899
	Slots	54"W	AMS2054RH	\$ 906	\$ 942	\$ 978
		60"W	AMS2060RH	\$ 1014	\$ 1055	\$ 1094
		66"W	AMS2066RH	\$ 1109	\$ 1153	\$ 1196
		72"W	AMS2072RH	\$ 1160	\$ 1206	\$ 1251
30"H Metal L-Screen						
		48"W	AMS3248LH	\$ 1081	\$ 1124	\$ 1166
	Extended	54"W	AMS3254LH	\$ 1145	\$ 1191	\$ 1235
		60"W	AMS3260LH	\$ 1196	\$ 1243	\$ 1290
		66"W	AMS3266LH	\$ 1312	\$ 1364	\$ 1415
		72"W	AMS3272LH	\$ 1363	\$ 1417	\$ 1470
	Extended Slots	48"W	AMS3248RH (shown)	\$ 1081	\$ 1124	\$ 1166
	Slots	54"W	AMS3254RH	\$ 1145	\$ 1191	\$ 1235
		60"W	AMS3260RH	\$ 1196	\$ 1243	\$ 1290
		66"W	AMS3266RH	\$ 1312	\$ 1364	\$ 1415
		72"W	AMS3272RH	\$ 1363	\$ 1417	\$ 1470
20"H Metal U-Screen						
		48"W	AMS2048US (shown)	\$ 1086	\$ 1130	\$ 1171
	Extended	54"W	AMS2054US	\$ 1145	\$ 1191	\$ 1235
		60"W	AMS2060US	\$ 1196	\$ 1243	\$ 1290
		66"W	AMS2066US	\$ 1312	\$ 1364	\$ 1415
		72"W	AMS2072US	\$ 1377	\$ 1432	\$ 1485
	Extended Slots					
	Slots					
30"H Metal U-Screen						
		48"W	AMS3248US (shown)	\$ 1304	\$ 1356	\$ 1406
	Extended	54"W	AMS3254US	\$ 1374	\$ 1428	\$ 1482
		60"W	AMS3260US	\$ 1435	\$ 1492	\$ 1547
		66"W	AMS3266US	\$ 1574	\$ 1635	\$ 1697
		72"W	AMS3272US	\$ 1653	\$ 1718	\$ 1782
	Extended Slots					
	Slots					

ALTITUDE

<p>How to specify — Select the Model Number from above.</p>	<p>1st Option: Wing Type :</p> <p>STD Standard EXT Extended</p>	<p>2nd Option: Accessories Slots:</p> <p>X No Accessory Cut Out SLT Accessory Cut Out</p>	<p>3rd Option: Paint Option:</p> <p>P1 P2 P3 See page 398 for finishes.</p>	<p>4th Option: Paint Option:</p> <p>NA Screen</p>
	<p>_____ . _____ . _____ . P _____ . NA</p>			

Examples: AMS2048LH.STD.SLT.PR6.NA AMS2048SS.PR6.NA



Shippable by small-package carrier.

For specification information see pages 407-408.

GSA SIN 33721

Description	Model	P1 Paint List Price	P2 Paint Upcharge	P3 Paint Upcharge
20"H Metal Rectangular Screen				
48"W	AMS2048SS (shown)	\$ 710	\$ 739	\$ 766
54"W	AMS2054SS	\$ 746	\$ 776	\$ 805
60"W	AMS2060SS	\$ 796	\$ 828	\$ 858
66"W	AMS2066SS	\$ 906	\$ 942	\$ 978
72"W	AMS2072SS	\$ 978	\$ 1018	\$ 1056
30"H Metal Rectangular Screen				
48"W	AMS3248SS (shown)	\$ 870	\$ 904	\$ 938
54"W	AMS3254SS	\$ 906	\$ 942	\$ 978
60"W	AMS3260SS	\$ 964	\$ 1002	\$ 1041
66"W	AMS3266SS	\$ 1086	\$ 1130	\$ 1171
72"W	AMS3272SS	\$ 1145	\$ 1191	\$ 1235
15"H Tackboard Accessories				
20"W	AAS1520 S	\$ 309	\$ 322	\$ 333
48"W	AAS1548 S (shown)	\$ 367	\$ 383	\$ 396
54"W	AAS1554 S	\$ 406	\$ 423	\$ 438
60"W	AAS1560 S	\$ 423	\$ 441	\$ 456
66"W	AAS1566 S	\$ 617	\$ 641	\$ 666
72"W	AAS1572 S	\$ 675	\$ 702	\$ 729

<p>How to specify — Select the Model Number from above.</p>	<p>1st Option: Wing Type : STD Standard EXT Extended</p>	<p>2nd Option: Accessories Slots: X No Accessory Cut Out SLT Accessory Cut Out</p>	<p>3rd Option: Paint Option: P1 P2 P3 See page 398 for finishes.</p>	<p>4th Option: Paint Option: NA Screen</p>	<p>5th Option: Accessories Color (if applicable): DW Designer White E9 Flint</p>
<p>Examples: AAS1548.PR6.APN911 AFAMS2048LH.STD.SLT.PR6.NA AFAMS2048SS.PR6.NA</p>					

Work Tools	Description	Model	List Price
	Hot File (Designer White Only) 9½"H x 12¼"W x 3¾"D	AEHF	\$ 64
	Side Saddle (Designer White Only) 4"H x 12¼"W x 2½"D	AESS	\$ 53
	Bag or Coat Hook (Designer White Only) 3¼"H x 1½"W x 2¼"D	AECH	\$ 41

<p>How to specify — Select the Model Number from above.</p>	<p>1st Option: Paint Option (if applicable): P1 P2 P3 See page 398 for finishes.</p>	<p>2nd Option: Fabric Option (if applicable): See page 399 for fabric options.</p>	<p>3rd Option: Paint Option: NA Screen</p>	<p>4th Option: Accessories Color (if applicable): DW Designer White E9 Flint</p>
<p>Example: AEHF.PJW</p>				

S Shippable by small-package carrier.

For specification information see pages 409-414.

GSA SIN 33721

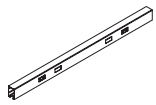

Description	Model	Ship Weight	Cubes	List Price		
				P1	P2	P3
Power Rail						
48"	RFDRW48	7	0.6	\$ 632	\$ 680	\$ 750
54"	RFDRW54	8	0.6	\$ 667	\$ 717	\$ 790
60"	RFDRW60 (shown)	9	0.7	\$ 768	\$ 824	\$ 909
66"	RFDRW66	10	0.8	\$ 819	\$ 879	\$ 967
72"	RFDRW72	11	0.9	\$ 924	\$ 991	\$ 1090

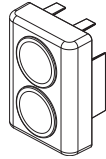

Power Rail End Cap	FDRWEC	1.5	0.1	\$ 235	\$ 253	\$ 278
--------------------	--------	-----	-----	--------	--------	--------

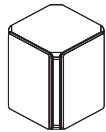

Power Rail Universal Connector	FDRWUC	3	0.1	\$ 428	\$ 458	\$ 503
--------------------------------	--------	---	-----	--------	--------	--------

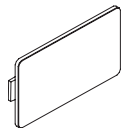

Electrical Port Cover						
2 Pack	FDEPC2	1	0.1	\$ 64	\$ 70	\$ 76
12 Pack	FDEPC12	2	0.1	\$ 220	\$ 237	\$ 260

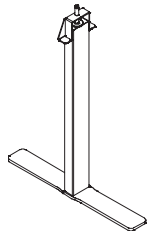

Elevated Power Rail Legs 20.5"H	RFDRWLEG	5	0.1	\$ 385	\$ 388	\$ 388
---------------------------------	----------	---	-----	--------	--------	--------

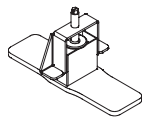

Floor Mount Legs	FDRWLEG	5	0.1	\$ 84	\$ 87	\$ 89
------------------	---------	---	-----	-------	-------	-------



Altitude Power Rail Floor Anchor Bracket	RFDRWAB	2	0.1	\$ 55	\$ 73	\$ 80
--	---------	---	-----	-------	-------	-------

ALTITUDE

How to specify —
Select the Model Number from above.

1st Option:

Paint:

P1 P2 P3

See page 398 for selections and color codes.*

Examples: _____ .

Examples:

For specification information see pages 409-414.

GSA SIN 33721

Description	Model	Ship Weight	Cubes	List Price		
				P1	P2	P3
Hubs						
End of Run Linear Configuration	RFDRWHUBEND	10	4	\$ 1097	\$ 1104	\$ 1110
End of Run T-Configuration	RFDRWHUBENDT	10	4	\$ 1097	\$ 1104	\$ 1110
Inline Linear Configuration	RFDRWHUBLIN	14	4	\$ 1097	\$ 1104	\$ 1110
Inline X-Configuration	RFDRWHUBX	14	4	\$ 1097	\$ 1104	\$ 1110
Inline T-Configuration	RFDRWHUBT	13	4	\$ 1097	\$ 1104	\$ 1110
L-Configuration Hub	RFDRWHUBL	13	4	\$ 1097	\$ 1104	\$ 1110

ALTITUDE

<p>How to specify — Select the Model Number from above.</p>	<p>1st Option: Paint: P1 P2 P3 See page 398 for selections and color codes.*</p>
--	--

Examples:

For specification information see pages 409-414.

GSA SIN 33721

Description	Model	Ship Weight	Cubes	List Price		
				P1	P2	P3
Power Pole						
8' H Square Power Pole	UN2HPSQ	17	1	\$ 1138	\$ 1156	\$ 1169
Square Power Pole Splicer Kit	UN2HPSQSK	0.5	0.1	\$ 125	\$ 129	\$ 130
Power Pole Connector	RFDRWCNPP	1	0.1	\$ 236	\$ 239	\$ 241
Power Pole Connector - End Condition	RFDRWCNPPE	1	0.1	\$ 236	\$ 239	\$ 241
Power Pole Connector - Mid Condition	RFDRWCNPPM	1	0.1	\$ 236	\$ 239	\$ 241

UN2HPSQ



UN2HPSQSK

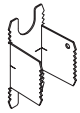

RFDRWCNPP

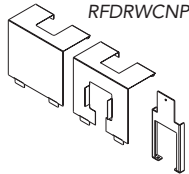

RFDRWCNPPE

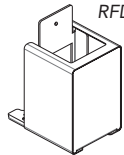

RFDRWCNPPM

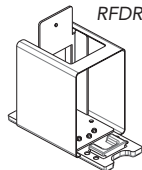

Wire Management

Vertebrae Wire Manager	RFDRWWM	3	0.1	\$ 721	\$ 739	\$ 746
------------------------	---------	---	-----	--------	--------	--------

*Includes connector for Power Rail attachment

*Vertebrae available in black only, connector available in 32 standard paints.

How to specify —

Select the Model Number from above.



Examples:

1st Option:

Paint:



See page 398 for selections and color codes.*



For specification information see pages 409-414.

GSA SIN 33721

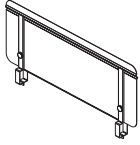

Description	Model	Ship Weight	Cubes	List Price		
				P1	P2	P3
Allsteel Metal Screen						
48"	RFDRWSC48	10	3.52	\$ 394	\$ 404	\$ 416
54"	RFDRWSC54	11	3.84	\$ 418	\$ 428	\$ 440
60"	RFDRWSC60	12	4.21	\$ 433	\$ 445	\$ 458
66"	RFDRWSC66	13	4.58	\$ 441	\$ 453	\$ 466
72"	RFDRWSC72	14	4.96	\$ 473	\$ 485	\$ 498

ALTITUDE

<p>How to specify — Select the Model Number from above.</p> <p>_____ .</p>	<p>1st Option: Paint: P1 P2 P3 See page 398 for selections and color codes.*</p> <p>_____</p>
---	---

















Examples:

Accessories

Worksurface Mounted Rail and Accessories



For specification information see page 421.

GSA SIN 33721

Description	Model	List Price		
		P1	P2	P3
Accessories Rail — Worksurface Mounted				
12"W	U912WTR 	\$ 120	\$ 128	\$ 132
18"W	U918WTR 	\$ 128	\$ 136	\$ 140
24"W	U924WTR 	\$ 147	\$ 155	\$ 159
30"W	U930WTR 	\$ 164	\$ 175	\$ 182
36"W	U936WTR 	\$ 186	\$ 197	\$ 204
42"W	U942WTR 	\$ 201	\$ 212	\$ 219
48"W	U948WTR 	\$ 212	\$ 227	\$ 232
54"W	U954WTR 	\$ 221	\$ 237	\$ 241
60"W	U960WTR 	\$ 232	\$ 249	\$ 255
66"W	U966WTR 	\$ 279	\$ 296	\$ 302
Rail Mounted Accessories				
Phone/Tablet Stand — 6½"H x 4¼"W	U9TM 	\$ 181	\$ 194	\$ 204
Pencil Holder — 2½"H x 6"W x 3"D	U9TP 	\$ 110	\$ 121	\$ 128
Shelf — 8"W x 4½"D; 2½" above top of worksurface	U9TS 	\$ 132	\$ 145	\$ 155
Vertical Paper Tray — 12"H x 1⅝"W x 12"D	U9TF 	\$ 198	\$ 211	\$ 221
Cord Organizer				
4"W x ⅞"D Metal with 4 cable cutouts	U9WTC 	\$ 196	\$ 205	\$ 212
Universal Hook (Black only)				
Package of 2	AGSAUHK 	\$ 132	—	—

How to specify —
Select the Model Number from above.

U | 9 | | | | | | | .

1st Option:
Paint:
  
See page 398 for selections and color codes.*

| | | |

Examples: U912WTR.PR6 U9TF.P7G AGSAUHK.P27

 Shippable by small-package carrier.

Extensions — Introduction

Extensions accessory line by Allsteel is designed to help you create your own space.

- **Create a personalized space**

Each person works differently, different work styles require different tools. As our workplace needs shift from paper filing to personal storage, the tools that support us day-to-day need to adapt to the changing ways we are expected to work. Whether it's the need for paper filing, a place to plug a charger in, or a small shelf for trinkets, Extensions help you bear it all.

- **Create a comfortable space**

Encourage wellness and peace of mind while you work with Extensions. Whether by clearing valuable desk space, routing cords out of the way, powering your technology, or illuminating tasks with a gentle glow, this full line of work tools help you stay calm and in control of your workspace.

- **Create an empowered space**

Without all the right tools you need to succeed, having a productive workday can feel like an impossible task. With a full line of ergonomic, organization, illumination, power, and wire management tools, Extensions put the right tools within reach, allowing you to get your work done seamlessly and efficiently.

- **Organization tools**

Embracing organization work tools can help add efficiency and excitement to your daily workflow. Durably made but thoughtfully designed to help you organize and store the tools you need throughout your day, Extensions organizational tools help you find that perfect place for anything.

- **Ergonomic tools**

Ergonomics is more than just comfort, it's flexibility and safety. The adjustable keyboard options allow users to maintain and vary comfortable wrist and arm positions throughout the day, whether typing or mousing. Monitor Arms offer versatile adjustability while providing optimum comfort for the eyes, neck, and shoulders.

- **Illumination tools**

Sleek and flexible, our lighting components offer you several choices. Recessed task lights conserve space and feature electronic ballast for longer bulb life and cooler operating temperature. LED tasklights' slim design blends in with its surrounding while utilizing energy-efficient LED technology.

- **Power/Data tools**

At the heart of every workspace is a power module that keeps you plugged-in and running throughout the day. These indispensable accessories provide wired or wireless connectivity anywhere and everywhere you could possibly need it, transforming your workplace into a hub of activity.

- **Wire Management tools**

Eliminate the cord clutter under your desk with our extensive wire management offering. Allsteel wire management accessories effortlessly weave wires out of the way and clear your workspace with ease. Both free-standing and height adjustable, table-integrated solutions ensure that your space stays as clear as your workflow.

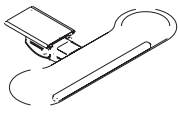
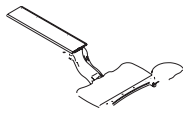
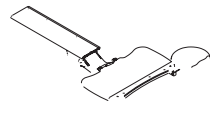
Articulating Keyboard Supports			
Features	Model AKTSHORT	Model AKTLONG	Model AKTMID
			
Keyboard Support	Platform style 28"W x 8"D	Platform Style 19"Wx11"D	Platform Style 19"Wx11"D
Keyboard Support Material	Phenolic	Phenolic	Phenolic
Suspension	<ul style="list-style-type: none"> Nylon glides on lubricated slide track Intuitive lift and lock one touch height adjustment 	Lubricated slide track system: spring assisted	Lubricated slide track system: spring assisted
Platform Rotation	360 degrees	360 degrees	360 degrees
Platform Tilt	+10/-20 degrees	+10/-20 degrees	+10/-20 degrees
Platform Tilt Adjustment	Soft touch lever for precise tilt adjustment	Convenient tilt wheel assists desired tilt angle	Convenient tilt wheel assists desired tilt angle
Platform Height Adjustment Range	6½" (1½" above / 5¼" below)	12½" (7" above to 5½" below)	8" (3" above / 5" below)
Platform Height Adjustment	Lift platform to raise, lift slightly and tilt back to lower	Lift platform to raise, lift slightly and tilt back to lower	Lift platform to raise, lift slightly and tilt back to lower
Palm Rest	Detachable leatherette-covered gel palm rest	Fabric covered gel palm rest	Fabric covered gel palm rest
Mouse Pad	In-line to accommodate mouse on same level as keyboard.	Circular, swivel, tilt, LH/RH mounting, mouse catcher, gel rest	Circular, swivel, tilt, LH/RH mounting, mouse catcher, gel rest
Microsoft Natural Compatible	No	Yes — by removing palm rest	Yes — by removing palm rest
Track Depth	8"	23"	21"
Required Mounting Clearance	20"W x 8"D x ¼" Recess	19"W x 23"D + ¼" Recess	19"W x 23"D + ¼" Recess
Adjustable Wrist Rest	No	Fixed mounting and height	Fixed mounting and height
Ideal For	<ul style="list-style-type: none"> Straight worksurfaces ADA/HFES compliance Extensive adjustability with mouse in line, mouse over or mouse forward of keyboard Height-Adjustable Table 	<ul style="list-style-type: none"> Corner worksurface applications Sit to stand applications 	<ul style="list-style-type: none"> Shallow worksurfaces Corner worksurface (17" or 21") Radius worksurface (42" or 48")
Additional Information		<ul style="list-style-type: none"> Track can be cut in the field to shorten track depth — may affect ability to fully recess platform 	<ul style="list-style-type: none"> Track can be cut in the field to shorten track depth — may affect ability to fully recess platform

AKTSHORT Keyboard Support (page 442)

- Lift and lock intuitive height adjustment.
- Compatible with Altitude Height Adjustable Tables
- Positive and negative tilt for best ergonomic positioning.
- +10°/-20° tilt adjustment and 360° rotation provides support of neutral position of shoulders, arms and wrists while accommodating multiple working postures.
- Surpasses ANSI/BIFMA standards.
- Black powder coat finish.
- Patented secondary slide and unique arm design provide minimal footprint.

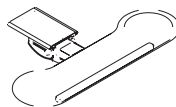

Keyboard Spacer Kit (page 442)

- Keyboard Spacer Kit required for mounting under Altitude worksurfaces.
- Kit provides ten spacers and hardware for mounting keyboard supports beneath an external worksurface support channel.
- Spacers are 2⅞"H providing more room beneath surface for mounting.

CPU Hammock (page 442)

- Features 360-degree swivel with an 11" track.
- Load capacity is 75 lbs.
- CPU must be minimum of 3¼"W with maximum dimension of 64" in perimeter.
- Handy adjustment tool stores within unit.
- Safety feature prevents accidental release of straps and straps can be adjusted while CPU is installed.
- Can be used on Height Adjustable Tables as long as it is attached with spacer model AKMH. Take into account required leg room for users.







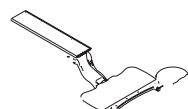
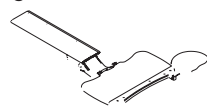



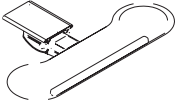

AKTMID and AKTLONG Keyboard Support (page 442)

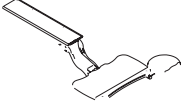
- Lift and lock intuitive height adjustment.
- Positive and negative tilt for the best ergonomic positioning.
- +10°/-20° tilt adjustment and 360° rotation provides support of neutral position of shoulders, arms, and wrists while accommodating multiple working postures.
- Non-handed mouse tray can be moved from right hand to left hand side.
- Surpasses ANSI/BIFMA standards.
- Black powder-coat finish.

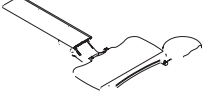

For specification information see page 441.

GSA SIN 33721

	Description	Model	List Price						
	Compact Keyboard Support with 8" Track 30"W x 13"D	AKTSHORT 	\$ 603						
	STS Keyboard Support with 23" Track 24"W x 12"D	AKTLONG 	\$ 739						
	Articulating Keyboard Support with 21" Track 24"W x 12"D	AKTMID 	\$ 635						
	Keyboard Spacer Kit 10 – 2½"H Spacers and Hardware	AKMH 	\$ 65						
	CPU Hammock™ (Silver only) 360° swivel CPU holder with adjustable straps	ACPU1 	\$ 431						
	Metal Corner Sleeve — for use with Optimize™, Concensys®, and Terrace® • Fits 1¼" thick square edge detail. (T-Mold worksurfaces) 22½"W leading edge x 18"D.	AWCS	<table border="1"> <thead> <tr> <th>P1 Paint List Price</th> <th>P2 Paint List Price</th> <th>P3 Paint List Price</th> </tr> </thead> <tbody> <tr> <td>\$ 152</td> <td>\$ 158</td> <td>\$ 163</td> </tr> </tbody> </table>	P1 Paint List Price	P2 Paint List Price	P3 Paint List Price	\$ 152	\$ 158	\$ 163
P1 Paint List Price	P2 Paint List Price	P3 Paint List Price							
\$ 152	\$ 158	\$ 163							

Edge Details

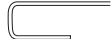

Model AWCS

How to specify —
Select the Model Number from above.



Examples: AKMH ACPU1

 Shippable by small-package carrier.

Allsteel's tool rail works in conjunction with a variety of accessories. Modular accessories free up worksurface space and provide orderly storage that is well within reach. Units can be arranged and rearranged to respond to changing workflow. The work tools that attach to the tool rail are:

- Mail Box
- Folder Holder
- Phone Caddy
- Binder Bin
- Tool Box
- Clip Caddy™
- Sidebar™ Personal Shelf
- Paper Wave™
- Cup Holder
- Hook
- Hanging File Holder
- Magnetic Picture Holder
- Small Bin
- Small Shelf
- Small Tray

Additional accessories that work with the **tool rail work tools** aesthetically are:

- Bookends
- Freestanding Mail Box

Coat hooks, marker boards and center drawers round out the organization offering.

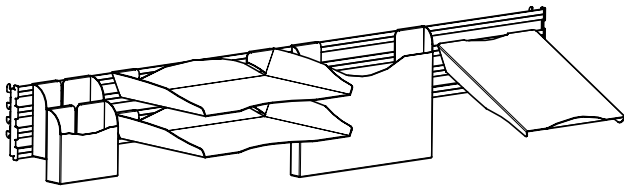

Tool rail, shown above, is height-adjustable in 1" increments using slots in panels or metal hutch. Tool rail shown with two tool boxes, two mail boxes, folder holder, and phone caddy. Folder holders and binder bins extend below a tool rail. Paper Wave and contents extend above a tool rail.

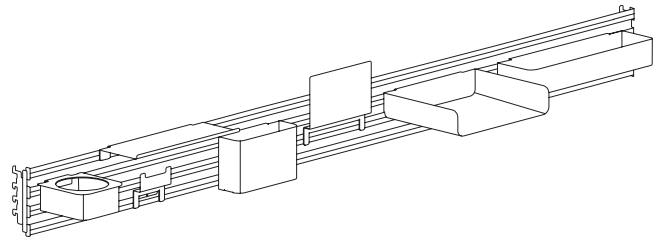

Tool rail, shown with cup holder, small shelf, hook, small bin, magnetic picture holder, small tray, and hanging file holder.

Tool Rails and Work Tools (page 446)

- Sturdy aluminum extrusion with steel support construction.
- Powder coated for durable finish.
- Use to hang Extensions tools. Cannot be used to support monitor arms.
- Suggested weight capacity not to exceed 80 lbs.
- Consideration needs to be given to height of tools and location of worksurfaces.
- For use with Terrace®, Concensys®, and Optimize™ systems.
- 5" high rail (widths coordinate with panels).
- Attachment via vertical reveals.
- Can be hung from wall track. Good solution for above copiers.
- Systems tool rail is off-modular — can be used on a panel of equal width or one size smaller.
- May span two panels of appropriate size, i.e., 60" W Tool Rail on two 30" W panels.

Tool Rail for Hutches (page 446)

- Will work on Universal, Terrace, Optimize, and Concensys system hutches produced after July 2, 2000 and Align™ metal hutches.
- Sturdy aluminum extrusion with steel support construction.
- Powder coated for durable finish.
- Use to hang Extensions tools. Cannot be used to support monitor arms.
- Suggested weight capacity not to exceed 80 lbs.
- Consideration needs to be given to height of tools and location of worksurfaces.

Mail Box (page 447)

- Holds standard letter-size paper and inter-office envelopes.
- Minimal horizontal intrusion.

Folder Holder (page 447)

- Holds manila envelopes.
- Is capable of hanging on other folder holders to maximize space.
- Stores vertically for easy access to files.

Phone Caddy (page 447)

- Holds telephone at optimum ergonomic angle.
- Wire management cut-outs.
- Accommodates standard phone sizes.

Binder Bin (page 447)

- Holds folders, binders, and manuals.

Tool Box (page 447)

- Holds pencils and other writing utensils, large post-it notes, and other desk top accessories.

Clip Caddy™ (page 447)

- Holds paper clips and other small objects.

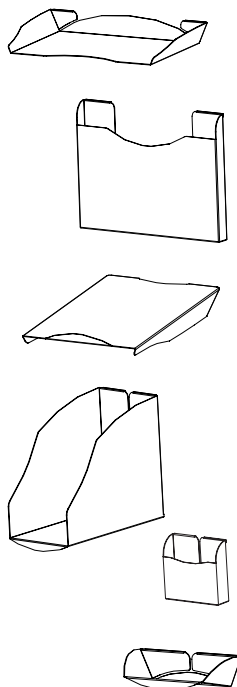



Sidebar™ Personal Shelf (page 447)

- Holds office supplies and personal effects.

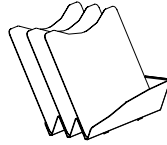

Paper Wave™ (page 447)

- Provides 3 fully divided slots for organizing files.
- Keeps papers from “bowing” at bottom.

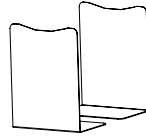

Bookends (page 447)

- Can be used on shelves or in cabinets.
- Used to hold books, binders, and catalogs upright.

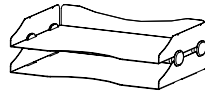

Freestanding Mail Box (page 447)

- Incorporates similar aesthetic to mounted Mail Box.
- Mounting brackets allow for free access from front and back.
- Sold in pairs of two; will stack up to eight high.
- Individual mail box dimension = 1¼”H.
- Stacking brackets are black.



Coat Hook APMC6 (page 447)

- Hangs directly into slotted Terrace® or Optimize™ panel frame.
- Use for coat or bag.
- Package of six.
- Available in black only.

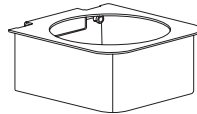

Cup Holder (page 447.1)

- Holds most cups and thermoses. Weight capacity is 5 lbs.

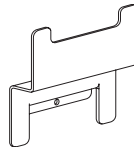

Hook (page 447.1)

- Hangs small personal effects such as headphones, keys, or hand wallets. Weight capacity is 10 lbs.



Hanging File Holder (page 447.1)

- Hangs files and folders from hanging file clips. Hanging file clips not included. Weight capacity is 5 lbs.

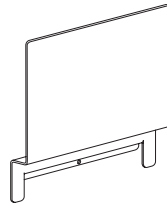

Magnetic Picture Holder (page 447.1)

- Allows for pictures to be hung via magnets. Magnets not included. Weight capacity is 5 lbs.

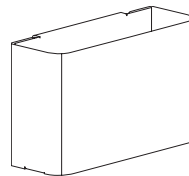

Small Bin (page 447.1)

- Houses office supplies or other personal effects such as pencils, pens, sticky notes, journals, etc. Weight capacity is 5 lbs.



Small Shelf (page 447.1)

- Provides additional shelf storage in workstation and displays office supplies or personal effects. Weight capacity is 5 lbs.



Small Tray (page 447.1)

- Holds office supplies and other personal effects. Weight capacity is 5 lbs.



ACPWRMOD

Power/Data Module — Clamp On Worksurface (page 453)

- On-surface mounting option, fits on any worksurface with a 4" overhang.
- 10' straight power cord only. UL Listed.
- Includes adapters to allow use of commercially available data terminals or blanks to fill unused openings. Many of the AMP, AT&T, Krone, Leviton, and most commercial data terminals can be used.
- Available in Fog only.

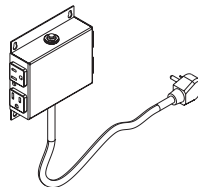

APWR4TAP

Power Module — Under Worksurface, Quad Tap (page 453)

- Under surface mounting can be used under any surface with a 5" x 5" x 1.5" clearance.
- 10' straight power cord only, no specification needed.
- 4 receptacles, unit is black finish only, no specification needed.

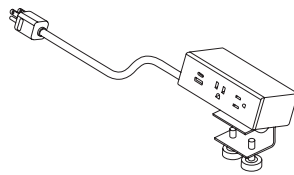

APWRMOD.AC.S

Power Modules — Clamp On Worksurface, Rectangular (page 453)

- Worksurface clamp can be used on any surface with a 2½" overhang.
- Must be installed at time of initial worksurface installation if installing between a worksurface and panel.
- 10' straight power cord only. UL Listed.
- The USB hub allows simultaneous powering of 2 receptacles, 1 USB-A device, and 1 USB-C device. The USB hub is a charger only, no ability to connect to a PC. The charging capacity is limited and may not charge all devices.
- Four wire management "P-Clips" included with mounting hardware.
- Specify "QA" for Qi compatible wireless charging on AWPRMOD. USB-C port no longer included when wireless charging specified.
- Available in Snow and Storm finishes.

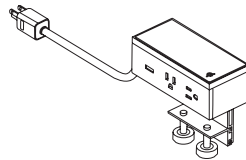

APWRMOD.QA.S

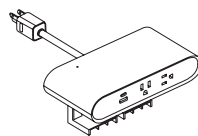

ARNDPWRMOD.QA.S

Power Modules — Clamp On Worksurface, Round (page 453)

- Worksurface clamp can be used on any surface with a 2½" overhang.
- Must be installed at time of initial worksurface installation if installing between a worksurface and panel.
- 9' straight power cord only. UL Listed.
- The USB hub allows simultaneous powering of 1 USB-A device and 1 USB-C device. The USB hub is a charger only, no ability to connect to a PC. The charging capacity is limited and may not charge all devices.
- Specify "QA" for Qi compatible wireless charging on ARNDPWRMOD.
- Available in Snow and Storm finishes.

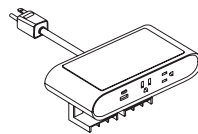

ARNDPWRMOD.AC.S

Power Module — Under Worksurface, Rectangular (page 453)

- Under surface mounting can be used on any surface with a 5" clearance.
- Power cord choices include 10' Straight, 5' Interlink, 10' Hardwire, and 10' Chevron Fog & Storm Braided cords. All are UL listed.
- Four wire management "P-Clips" included with mounting hardware.
- Available in Snow, Storm, and Black finishes.

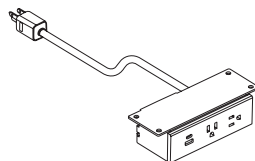

AUPWRMOD.AC.S

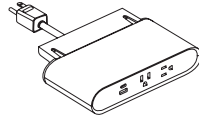

AURNDPWRMOD.AC.S

Power Module — Under Worksurface, Round (page 453)

- Under surface mounting can be used on any surface with a 5" clearance.
- 9' straight power cord only. UL Listed.
- Available in Snow, Storm, and Black finishes.

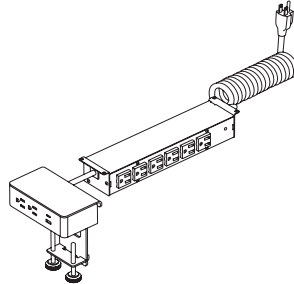

AABPWRMOD.AC.Q

Power Module — Above/Below Worksurface (page 453)

- Above/Below power module provides access to power on the desktop and below the worksurface.
- Desktop mount can be used on any surface with a 6"W x 3"D clearance along the worksurface edge.
- Under surface mounting can be used with a 12"W x 3"D x 2"H clearance under the surface.
- Plugs will take additional depth (approx. 3").
- Two wire management "P-Clips" included with mounting hardware.
- Below worksurface power strip supplies six grounded A/C receptacles, desktop unit supplies two receptacles, 1 USB-A port, and 1 USB-C port.
- Desktop and under worksurface units are connected by a 2' long straight cord and cannot be disconnected.
- Power cord choices include a 6' straight cord or a coiled cord that is 6' long uncoiled, approximately 8" long coiled (compressed).
- Desktop unit available in White and Gray finishes.
- Under worksurface unit available in black only, no specification needed.
- UL 962A and UL 111 Listed. UL 1310 Recognized.

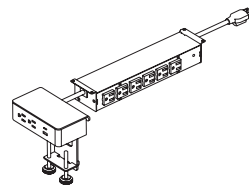

AABPWRMOD.AC.S

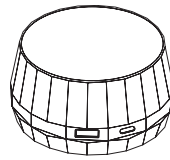

APWRPCK

Power Module — Sit-on-Surface, Puck (page 453.1)

- Unit sits on top of a worksurface.
- Includes 5' DC Connector cord, transformer block, and 6' AC straight cord for 11' of total cord length. UL 1310 Listed.
- Unit allows for simultaneous powering of 1 USB-A and 1 USB-C device.
- Unit is a charger only, no ability to connect to a PC other than to charge.
- Available in White and Silver finish only, no specification needed.

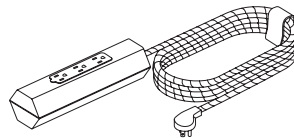

APWRSTRP

Power Strip — Sit-on-Surface, Wood (page 453.1)

- Unit sits on top of a worksurface.
- 10' Braided cord in White nylon, leather cord management strap included. UL Listed.
- Ultra-low profile 45 degree flat plug.
- 3 grounded power outlets.
- Solid Ash Wooden housing, no specification needed.



AVSTA3PWR

Vesta Mobile Power (page 453.1)

- 3 AC power simplex, 1 dual USB-A, 1 USB-C configuration.
- 10' Retractable power cord, UL Listed.
- Unit weighs 13 lbs.
- For cordless, battery-powered unit, please contact the Tailored Product Group (TPG).
- Available in Snow, Storm, Black, and Fog. Separate finish options available for outside and inside of unit.

Cable & Wire Management

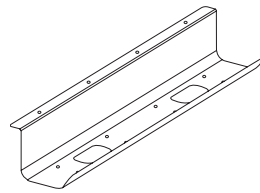

AJTRGH24 or AJTRGH36

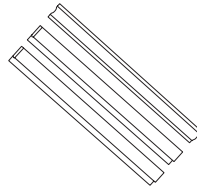

AWRSTRIP

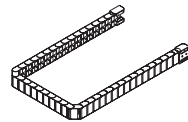

A9CLWMC or WKSWMC

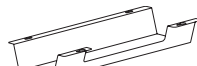

APWRTRGH17 or APWRTRGH36

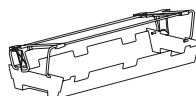

AFDTRGH20

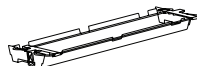

AFDTRGH32



ALEGCHASE26

Cable Management Tray (page 453.2)

- Attaches under the worksurface to contain cables.
- Metal tray shelf is 4" deep. Can hold electrical power strip and/or surge protector.
- 24" and 36" lengths, use multiple units for larger worksurfaces.
- Attachment hardware included, paint option is black only.
- Zip tie attachment points located in base of tray. Zip ties not included.

Wire Management Strips/Channels (page 453.2)

- Self adhesive backing to attach to panels and underside of worksurfaces.
- Flexible strips allow cabling to enter/exit and can be contained inside the strips' cavities.
- Includes two wire management profiles. Smaller profile allows for qty. 3, .3" diameter cords, has area of .32 in². Larger "J" shaped profile allows for qty. 10, .3" diameter cords, has area of 1.14 in².

Cord Management Chains (page 453.2)

- Works with Approach and Altitude A6-units.
- Used to route and conceal power/data cables from control box and other devices. Includes all mounting hardware and a plate to secure to a leveling glide.
- Houses 6 cables at 0.300" diameter.
- Made of plastic chain with plastic attachment brackets at each end.
- Specify WKSWMC for 58" chain. Only comes in Black finish.
- Specify A9CLWMC for 36" chain. Comes in Black, White, and Silver.
- Has two connecting points: Top section connects underneath a worksurface and bottom section can connect underneath power rails or to panel raceways using double-sided tape. Hardware included.

Under Worksurface Trough (page 453.2)

- Used to conceal wires and control box below worksurfaces. Trough can be configured at various height/width combinations to meet capacity needs. Ships flat and is bent to desired shape.
- On 48"W and 54"W worksurfaces use one 17"W trough. 54"W has space to use 2 – 17"W, if necessary.
- On 60"W, 66"W, and 72"W worksurfaces use the 36" trough.
- On 84"W worksurface use 2 – 17"W troughs.

Flip-Down Wire Trough (page 453.2)

- Mounts beneath a worksurface. Used to conceal extra cord slack and power strips.
- May be used in conjunction with quad tap unit APWR4TAP to reduce the number of cords routed from a worksurface to a beam.
- For any worksurface less than 58"W, a 20"W Flip-Down Trough is recommended.
- For worksurfaces 58"W and wider, a 20"W or 32"W Flip-Down Trough may be used.
- Flush-mount Raddi Storages are not recommended to use in conjunction with Flip-Down Trough.
- Only AKTSHORT keyboard tray is recommended for use in conjunction with the Flip-Down Trough.

O-Leg Chase (page 453.3)

- Works with O-Legs from Allsteel Approach.
- Matches leg profile on models WKTBTTL2824 and WKTBTTL2830.
- Magnetically aligns and adheres itself to the inside of the leg and allows for user to reposition and adjust wires as needed without the use of tools.
- Metal chase measures 26"H, can fit qty. 12, .3" diameter cords. Has cross section area of 1.56 in².
- Available in standard metal paint finishes.

Cable & Wire Management

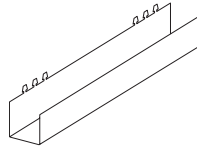

AMPCHASE

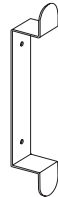

AWIRECLT

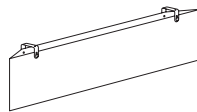

APWRMODEST36 or APWRMODEST48

Panel Mounted Wire Chase (page 453.3)

- Attaches between panels on Stride, Terrace, and Optimize via a slotted standard.
- Designed to sit below a worksurface and provide additional cord management from the base rail to beltline/under-worksurface height.
- Available in standard metal paint finishes.

Metal Wire Cleat (page 453.2)

- Supplied with screws and VHB tape for attachment to various surface types.
- For wood/particle board/MDF surfaces, use screw attachment.
- For painted metal/glass/non-porous surfaces, use VHB tape.
- Example use cases:
 - 1) Used alongside telescoping/fabric HAT wire chases to secure excess length of cord at plug-end.
 - 2) Secured to wall next to TV monitor in meeting room to manage HDMI cable when not in use.
 - 3) Screwed underneath worksurface to provide quick and easy management of excess length of cords and cabling.

Fabric Power Modesty (page 453.4)

- Fabric Power Modesty presents as modesty panel hanging by leather straps under a worksurface; inner compartment conceals cords and power strips as a wire management application.
- Recommended worksurface width pairings:
 - 1) 48-60" W Desk — Use APWRMODEST36 Centered.
 - 2) 66-72" W Desk — Use APWRMODEST48 Centered or APWRMODEST36 offset.
 - 3) 84" W Desk — Use APWRMODEST48 offset.
- Modesty fills 11.5 inches below the bottom of the worksurface with space for cords to enter/exit between the worksurface and the top of the Power Modesty.
- Two entry/exit points for cords are located at the bottom of the Power Modesty unit.
- Modesty panel is designed to present as a thin modesty panel from the front, but provides 3" depth cavity for wires, power strips, etc.
- Maximum weight capacity for Power Modesty is 25 lbs.
- Modesty panel not to be used to store electronics that require airflow for thermal management (computers).
- Users can access interior of panel (to modify wire placement) via "wings" on either side of product, secured via user-operable Velcro connection.
- Users may also dismount Power Modesty from leather straps by unlooping leather straps from button attachments.
- Leather straps on Power Modesty always come in medium brown color.
- Power Modesty available in Appoint, Binary, Centurion, Noble, Reflections, Disperse, and Spin fabric series.

Cable & Wire Management

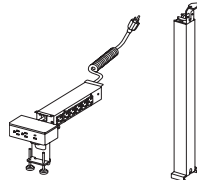

AHATPWORMOD2S or AHATPWORMOD3S

Metal Telescoping HAT Wire Management (page 453.4)

- Separate models available for use on either 2-Stage or 3-Stage Altitude A6 Tables. Not compatible with Altitude A3, A5, or A8.
- Equipped with 2-Stage or 3-Stage Telescoping Wire Chase and custom Above/Below Power Module intended for cord management on 2- and 3-Stage height adjustable tables.
- Telescoping chase includes a unique Above/Below Power Module and is NOT compatible with any other power module.
- Above/Below Power Module supplies 6 grounded A/C receptacles below the worksurface and 2 receptacles, 1 USB-A, and 1 USB-C port above the worksurface on the desktop unit. Desktop power module available in White and Gray finishes, below-worksurface power strip only available in black only.
- Telescoping Chase available in the same paint finishes as the Altitude height adjustable bases except for “Nickel.”
- To match Metal Telescoping Chase to HAT base, specify matching paint color as HAT base. To match Telescoping Chase to a “Nickel” HAT base, specify “Platinum Metallic,” or “PR2.”
- Two “P-Clips” included for wire management between desktop power module and under worksurface power strip.

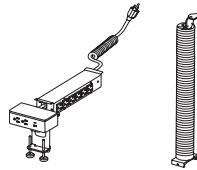

AHATPWORMOD2S or AHATPWORMOD3S

Fabric Elastic HAT Wire Management (page 453.4)

- Model compatible for use on either 2-Stage or 3-Stage Altitude A6 Tables. Not compatible with Altitude A3, A5, or A8.
- Equipped with Fabric Elastic Wire Chase and custom Above/Below Power Module intended for cord management on 2- and 3-Stage height adjustable tables.
- Fabric Elastic Chase includes a unique Above/Below Power Module and is NOT compatible with any other power module.
- Above/Below Power Module supplies 6 grounded A/C receptacles below the worksurface and 2 receptacles, 1 USB-A, and 1 USB-C port above the worksurface on the desktop unit.
- Desktop power module available in White and Gray finishes, below-worksurface power strip only available in black only.
- Fabric Elastic Chase available in Light, Medium, and Dark fabric finishes.
- Includes a metal foot and an under worksurface mounting bracket to attach Fabric Elastic Chase along the side of a HAT leg.
- To match metal brackets to HAT base, specify matching paint color as HAT base. To match brackets to a “Nickel” HAT base, specify “Platinum Metallic,” or “PR2.”
- Two “P-Clips” included for wire management between desktop power module and under worksurface power strip.

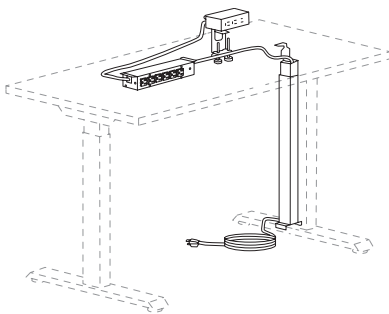

2-Stage Metal Telescoping HAT Wire Management

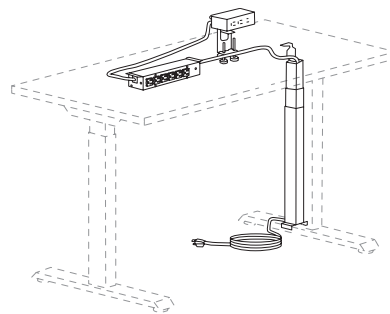

3-Stage Metal Telescoping HAT Wire Management

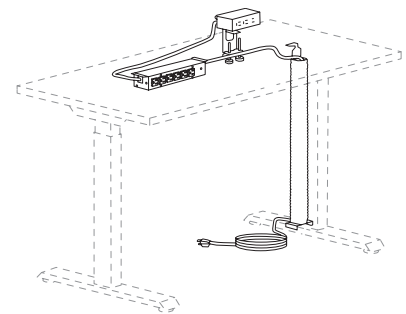

2 or 3-stage Fabric Elastic HAT Wire Management

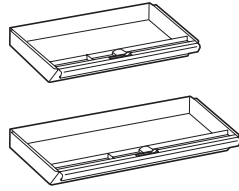

Metal Center Drawers (page 448)

- All metal center drawers feature pencil trays with three compartments for storage.
- Center drawers will not fit in center of 24" D worksurfaces which are wider than 60" due to location of center support bracket.
- For locking specifications, see pages 292-293 in the Desking and Benching Price & Specification Guide.
- Ball-bearing slide suspension.

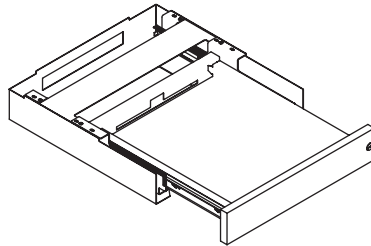

Laptop Drawer — U7WDA (page 448)

- Drawer body made of sheet metal.
- Drawer front made of 3/4" particleboard with laminate on both sides and fused laser edge banding.
- Core removable lock is located on right side drawer front
- 17 7/8" W x 18" D x 3 3/8" H Outside (interior 13" W x 16" D x 1 7/8" H)
- Minimum surface depth is 21" for surfaces not using an external stiffener; and 27" for surfaces using an external stiffener.
- Drawer extends 16"
- Maximum load: 45 lbs (functional BIFMA load)
- Drawer assembly and cover have cut out in back to allow for cables to exit drawer.
- Distance from floor to bottom of unit w/glides fully retracted is 24 3/4".
- Does not interfere with Further leg mounting plates so drawer can be placed directly next to either a system or table leg.
- When being placed next tower storage using the tower ell bracket (Z6LB) to support surface the drawer must be inset 3" to clear the ell bracket.
- Can be placed directly next to any support storage from any Allsteel product line (excluding towers).
- Flat brackets — drawer must be offset 3" from seam between surfaces to clear the bracket. See illustration at left.
- Can be used with rabbit edge worksurface models but there will be a larger reveal between surface and drawer.
- Can be used with knife edge worksurface models but reveal and depth need to be considered.

Flat Brackets

Front View



Top View

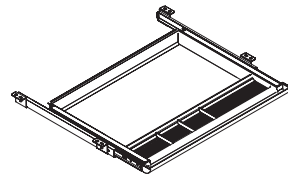
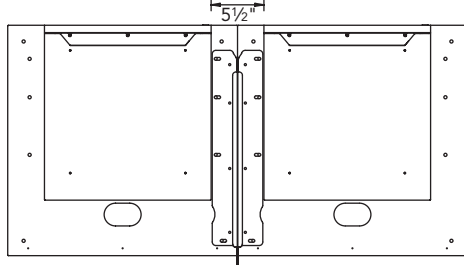

Polymer Center Drawer - ACD1 (page 448)

- 20 1/2" W x 17" D x 2" H
- Available in black only
- Made from ABS.
- Minimum clearance for mounting: 23" W x 16 1/4" D x 2" H.
- Retracts on 16" ball-bearing slides.
- Can be used on worksurfaces with Height Adjustable Bases as long as it is attached with spacer model AKMH.
- Can store up to 25 lbs.

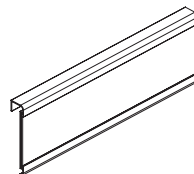

Name Plate (page 447)

- Comes in a 10-pack.
- Metal backer installs under a Terrace or Optimize top cap, can be used with frameless glass.
- Cover is a transparent polycarbonate insert.
- Full plate is 8 1/2" W x 2 3/8" H.

For specification information see pages 443-444.

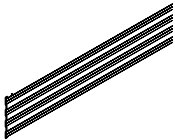
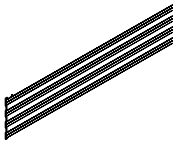

Description	Model	P1 Paint List Price	P2 Paint List Price	P3 Paint List Price
5"H Tool Rails — for Panels				
24"W	EASR24 S	\$ 267	\$ 305	\$ 340
30"W	EASR30 S	\$ 283	\$ 321	\$ 356
36"W	EASR36 S	\$ 295	\$ 333	\$ 368
42"W	EASR42 S	\$ 308	\$ 346	\$ 381
48"W	EASR48 S	\$ 317	\$ 355	\$ 390
60"W	EASR60 S	\$ 373	\$ 411	\$ 446
5"H Tool Rails — for Metal Hutches				
36"W	EAHSR36 S	\$ 295	\$ 332	\$ 366
42"W	EAHSR42 S	\$ 308	\$ 345	\$ 379
48"W	EAHSR48 S	\$ 317	\$ 354	\$ 388
60"W	EAHSR60 S	\$ 373	\$ 410	\$ 444
66"W	EAHSR66 S	\$ 385	\$ 422	\$ 456
72"W	EAHSR72 S	\$ 415	\$ 452	\$ 486

How to specify —
Select the Model Number from above.

1st Option:
Paint:
P1 P2 P3
See page 31 for finishes.









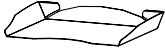
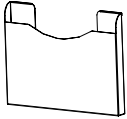

.P

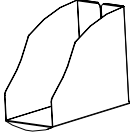
Example: EASR36.P02

S Shippable by small-package carrier.

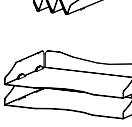
For specification information see pages 443-444.

GSA SIN 33721

	Description	Model	P1 Paint List Price	P2 Paint List Price	P3 Paint List Price
	Mail Box 9"D x 15"W	EAPT S	\$ 132	\$ 152	\$ 168
	Folder Holder 9"H x 12"W	EAFS S	\$ 135	\$ 155	\$ 171
	Phone Caddy 9"W x 11"D	EATS S	\$ 165	\$ 185	\$ 201
	Binder Bin 8½"H x 5¼"W x 10"D	EABS S	\$ 132	\$ 152	\$ 168
	Tool Box 5"H x 5¼"W x 1½"D	EADH S	\$ 106	\$ 126	\$ 142
	Clip Caddy™ 2"H x 7"W x 3½"D	EAC S	\$ 94	\$ 114	\$ 130
	Sidebar™ Personal Shelf 2"H x 21"W x 7"D	EAPS S	\$ 135	\$ 155	\$ 171
	Paper Wave™ Tray size: 2½"H x 6"W x 10"D Dividers: 9½"H x 9"W	EASS S	\$ 189	\$ 209	\$ 225
	Freestanding Mail Box (specify paint color) Pair — 4⅞"H x 13¼"W x 9"D	EAF S	\$ 271	\$ 291	\$ 307
	Coat Hooks (black only) Package of six	APMC6 S	\$ 132	N/A	N/A
	Panel Name Plate Package of 10	EACS	\$ 360	\$ 380	\$ 396

Note: Not for use on tool tile or rail, name plate installs under top cap on Terrace and Optimize.

How to specify —
Select the Model Number from above.

1st Option:
Paint:
P1
P2
P3
 See page 31 for finishes.











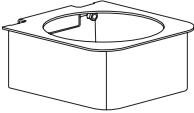

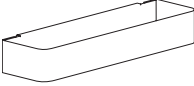
P | | | | .

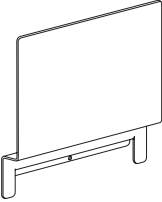
Examples: EAPT.P4J APMC6.P

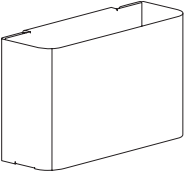
S Shippable by small-package carrier.

For specification information see pages 443-444.

GSA SIN 33721

	Description	Model	P1 Paint List Price	P2 Paint List Price	P3 Paint List Price
	Cup Holder 4 1/8"H x 2"W x 11 1/8"D	AAPAC 	\$ 259	\$ 285	\$ 298
	Hook 4 1/8"H x 3 1/2"W x 7 1/4"D	AAPAH 	\$ 195	\$ 215	\$ 224
	Hanging Folder Holder 4 3/8"H x 2 1/2"W x 14"D	AAPAHF 	\$ 258	\$ 284	\$ 297
	Magnetic Picture Holder 9"H x 10"W x 10 1/2"D	AAPAMP 	\$ 231	\$ 254	\$ 266
	Small Bin 5 1/8"H x 3 3/8"W x 7 1/8"D	AAPASB 	\$ 237	\$ 261	\$ 273
	Small Shelf 4"H x 2"W x 11 1/8"D	AAPASH 	\$ 222	\$ 244	\$ 255
	Small Tray 8 3/8"H x 2 7/8"W x 10 1/8"D	AAPAST 	\$ 260	\$ 286	\$ 299

How to specify —
Select the Model Number from above.

1st Option:

Paint:



See page 398 for finishes.







P | | | |



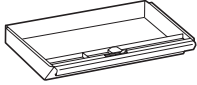

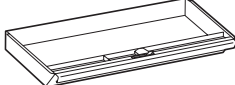

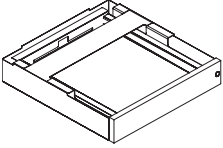
Examples: AAPAST.P4J AAPASB.P

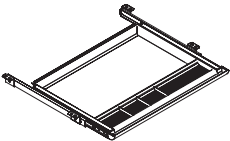
 Shippable by small-package carrier.

For specification information see pages 444-445.

GSA SIN 33721

	Description	Model	List Price		
			P1	P2	P3
 <p>Angled front</p>	Metal Center Drawer w/Lock 19"W x 14¼"D x 3"H • 12" drawer extension (3/4). • Inside drawer dimension: 19"W x 13"D x 2⅝"H. • Minimum clearance for mounting: 21¼"W x 19¼"D.	CSDC19 	\$ 305	\$ 327	\$ 346
 <p>Angled front</p>	24¼"W x 14¼"D x 3"H • 12" drawer extension (3/4). • Inside drawer dimension: 24½"W x 13½"D x 2⅝"H. • Minimum clearance for mounting: 27⅝"W x 19¼"D.	CSDC25 	\$ 314	\$ 336	\$ 355
	Laptop Drawer — Locking, laminate front, metal case 17⅞"W x 18"D x 3⅜"H • 16" drawer extension • Inside drawer dimensions: 13"W x 16"D x 1⅞"H • Minimum clearance for mounting: 17⅞"W x 21"D x 3⅜"H (see illustration)	U7WDA 	\$ 1750	\$ 1773	\$ 1792
	Polymer Center Drawer 20½"W x 17"D x 2"H • 11½" extension • Minimum clearance for mounting: 23"W x 16¼"D x 2"H	ACD1	\$ 244	N/A	N/A

<p>How to specify — Select the Model Number from above.</p>	<p><i>1st Option:</i> Laminate Edge (Laptop drawer front if applicable): See page 398 for finishes.</p>	<p><i>2nd Option:</i> Edge (Laptop drawer edge if applicable): See page 398 for finishes.</p>	<p><i>3rd Option:</i> Paint (If laptop drawer, list exterior case color here): See page 31 for finishes. Power Data Module PR6 Silver.</p>	<p><i>4th Option:</i> Paint (Interior of laptop drawer if applicable): See page 31 for finishes.</p>	<p><i>5th Option:</i> Lock (if applicable): STD Standard OMT Omit (Deduct \$20)</p>	<p><i>6th Option:</i> Lock or Tech Module Color (if applicable): EL Silver (Lock)</p>
						

Example: U7WDA.LM11EV.P27.PR6.STDEL

 Shippable by small-package carrier.

Allsteel Extensions offers Illumination in three styles — Undercabinet LED Light, Wand Light, and Splitty Light.

Recessed Undercabinet LED Light

Recessed task lights conserve space and provide an efficient solution for illuminating the workplace. All models are equipped with LED strips.

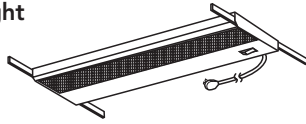

Recessed task light models mount under storage cabinets or shelves to provide optimal space utilization. Models are available in two styles and three sizes to correspond with the width of the cabinet or shelf. Task lights with a fused plug are available to meet Chicago electrical code.

Undercabinet LED Light

The Undercabinet LED Light is a low-profile, linear solution for overhead cabinets and shelves and is an ideal solution for painted wood storage. It utilizes energy-efficient LED technology which provides a long life. The Undercabinet LED Light provides the opportunity to mount the fixture where light is needed most.

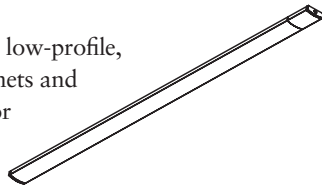

The Undercabinet LED Light features a metal trough reflector with diffuser lens. The light has a sleek 1/2" thick profile and provides two options for mounting, either magnetically or with hardware. Undercabinet LED Lights can be daisy-chained.

Optional undercabinet occupancy sensor is available which will automatically turn off the fixture after 30 minutes of no detection and back on immediately as the user re-enters the detection range using Passive Infrared (PIR) sensor technology. Unit features 360° lens with 90° outward detection angle, providing a 36" coverage diameter at 18". Occupancy sensor comes with connector and is required to be connected in the sequence shown below. Connect occupancy sensor to a light, or first light in daisy chain to control all linked lights.

CONNECTION SEQUENCE*

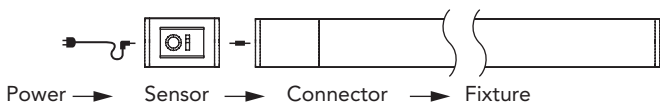

*Cannot deviate from this sequence

Recessed Task Lights (page 451)

- Black Metal Construction with 9' long black cord attached to right rear corner of the fixture.
- LED strip comes installed within light.
 - 50,000 hour life span
 - 120V-277V
 - CCT 4000K
 - CRI 80+
- Includes 4 cord retainer clips.
- Shorter width models can be used on wider overheads, shelves and hutches.
- On/Off switch provides individual control of tasklight within the workstation.
- Daisy chain models require a master control model — 10 fixtures maximum.
- RECOMMENDATION: Provide a separate circuit for task lights to ensure proper, long-term operation.

Undercabinet LED Lights (page 451)

- Low profile energy-efficient LED task light for use with overhead storage cabinets and shelves.
- 20W power supply for 10W 17" unit (.166 amps).
- 20W power supply for 20W 31" unit (.166 amps).
- 60W power supply for daisy-chain starter units (.5 amps). Must order one starter unit for each daisy-chain application.

LED Light Combinations Must Not Exceed 60W in Combination	Power Usage
6X 17"	60W
3X 31"	60W
1X 31" + 4X 17"	60W
2X 31" + 2X 17"	60W

- The combinations that could max out 60W are featured above. *Daisy chained units have a power limit of 60W from one power entry. 17W units use 10W and 31W units use 20W.*
- Specify up to 5 additional 17" interconnect units (ALED17UJMP30) to daisy-chain together with 17" daisy-chain starter fixture (ALED17U60).
Example: Daisy-chain 4 – 17" undercabinet LED lights:
Specify: 1 ALED17U60
Specify: 3 ALED17UJMP30 with 10" jumper cord
- Specify up to 2 additional 31" interconnect units (ALED31UJMP30) with 10" jumper cords to daisy-chain together with 31" tasklight (ALED31U60); or 17" daisy-chain starter fixture (ALED17U60).
- 3500K color temperature.
- 131 footcandles at 18" on ALED31U; 76 footcandles at 18" on ALED17U.
- Magnetic or screw-mount option — attachment hardware included.
- On 20 watt models, power drive is attached to plug: allow 1 1/8" D space at outlet.
- On 60 watt models, power drive brick is in center of cord.
- Includes 3 cord retainer clips.
- Meets California Title 24 Energy Efficiency Standards.
- "Instant On" switch with infinite dimming cycle from 100% to 15% with the last state memory, allowing the user to set their desired level of lighting.
- Fixture automatically turns off after 10 hours of use to reduce unwanted energy use.
- Optional occupancy sensor automatically turns off all interlinked fixtures after 30 minutes of no detection and back on immediately when detection is found.

Overhead Length	Suggested LED Sizes
24	17
30	17
36	17
42	31
48	17 + 17
60	31 + 17
72	31 + 31

Note: LED lights may need to be positioned along length properly to allow jumping to additional overheads. Suggested sizes above are recommendations for single overheads to provide as much light along length of overhead as possible.

The suggested sizes factor in 4 inches of room for the power inlet and occupancy sensor (optional).

Wand™ Task Light

Wand freestanding task light offers a clean, simple design along with powerful LED technology to illuminate the workspace. The swivel base and arm tilt allow users to position the light just where they need it. The 7.7 watt LED light offers efficiency and long life, providing up to 25 years of daily use. The slim, sleek design makes it easy to integrate into any workspace. Wand task light is 97% recyclable. Occupancy sensor and/or charging models available.

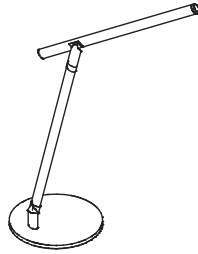

Wand LED Freestanding Task Light (page 452)

- Available in Silver or White. 9'4" cord is Silver.
- Full range dimming from 100% – 10% with last state memory.
- Uses 5W at highest setting and as low as 1 watt at its lowest setting, providing 75 to 12.7 footcandles of light, respectively (16" above worksurface).
- 7½" round swivel base and 16½"H tilt arm allow versatile positioning of the 13" lampshade.
- Designed for 50,000 hours of life.
- Color Temperature: 3500K. Color Rendering Index (CRI): 80.
- Materials: aluminum arm and lampshade, steel base.
- Weight: 4.4 lbs. 97% recyclable, 76% post-consumer.
- Certifications: UL and CUL. TAA compliant.
- Occupancy sensor available with automatic shut-off after 15 minutes if no motion is detected.
- USB model features USB-A (1), USB-C (1) charging within base of unit.
- USB model also features occupancy sensor. 7.5W (A) & 18W (C) power consumption.

Splitty Task Light

Splitty's organic and modern design compliments the workstation while also bringing rich features to the user. In addition to illuminating the space, Splitty can also be a teleconferencing tool through Splitty's 360-degree light head adjustment and soft touch, continuous dimming. Integrated charging allows for small personal device charging crucial to the modern worker's workplace toolkit while minimizing clutter within the station. Optional clamp or tool tile mounts available as accessories.

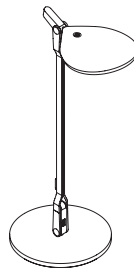

Splitty Task Light (page 452)

- Available in Silver, White, or Black (accessories available in silver only).
- Cord is 12' long.
- Cord is silver when black or silver finish specified, white when white light is specified.
- Soft touch on/off, dimming.
- Continuous dimming (100% – 3%) with last state memory.
- 5.8W of energy consumption. 7W at highest setting, 0.6W at lowest.
- 5" 360-degree swivel light head, 6.54" round swivel base and 17"H arm. Arm has full 180 degree rotation and 360 degree swivel.
- Designed for 60,000 hours of life.
- Color Temperature: 3500K, Color Rendering Index: 90.
- Materials: aluminum, plastic.
- USB-A has 5W of power consumption.
- USB-A (1) charging at bottom of light arm stem. Charging feature compatible for any mounting method.
- Clamp mount compatible with surfaces ¼" – 2¼" thick.
- Tool tile mount has 1½" adjustment range, minimum slot height of ⅜".

For specification information see pages 449-450.

Open Market / GSA SIN 33721 (as noted)

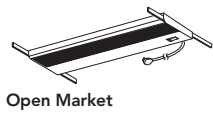

Open Market

Description	Watt Usage	Model	List Price
Recessed Task Lights (Black only) — Use recessed under overhead cabinets, storage shelves, or hutches, comes with cord retainer clips			
Task Light for 24"W	10	A870824 S	\$ 442
Task Light for 30"W and 36"W	14	A870830 S	\$ 446
Task Light for 42"W and 48"W	21	A870842 S	\$ 483
Task Light for 60"W, 66"W, and 72"W	28	A870860 S	\$ 522

Recessed Task Lights (Black only) — With fused plug (satisfies Chicago electrical code)

Task Light for 24"W	10	A870824CH S	\$ 570
Task Light for 30"W and 36"W	14	A870830CH S	\$ 581
Task Light for 42"W and 48"W	21	A870842CH S	\$ 618
Task Light for 60"W, 66"W, and 72"W	28	A870860CH S	\$ 654

Note: See below for GSA Approved Task Lights.

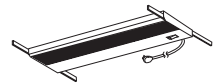

GSA SIN 33721

GSA Recessed Task Lights — Use recessed under overhead cabinets, storage shelves, or hutches

Base Models — Stand Alone

Task Light for 24"W	15	GS870924 S	\$ 565
Task Light for 30"W and 36"W	17	GS870930 S	\$ 583
Task Light for 42"W and 48"W	25	GS870948 S	\$ 627
Task Light for 60"W, 66"W, and 72"W	32	GS870960 S	\$ 671



GSA SIN 33721

Cord Retainer Clips (Black only)

Bag of 50 clips		AAPACM2 S	\$ 56
-----------------	--	---	-------

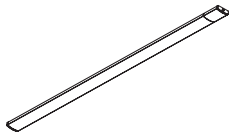

GSA SIN 33721

LED Undercabinet Light (white end caps)

17" Task Light w/20 watt power supply for 24"W or wider overhead	ALED17U	S	\$ 1045
17" Task Light w/60 watt power supply for daisy chain	ALED17U60**	S	\$ 1144
17" 10 watt Interconnect Task Light w/10" Jumper Cord	ALED17UJMP30	S	\$ 807
31" Task Light w/20 watt power supply 36"W or wider overhead	ALED31U	S	\$ 1568
31" Task Light w/60 watt power supply for daisy chain	ALED31U60**	S	\$ 1653
31" 20 watt Interconnect Task Light w/10" Jumper Cord	ALED31UJMP30	S	\$ 942
Undercabinet Occupancy Sensor 2 3/4"W + 1"W Connector	ALEDOCC*		\$ 636

*Undercabinet Occupancy Sensor works with LED Undercabinet lights shipped after 11/1/2013.

**When purchased separately without a configurable TAA compliant end product, not on GSA contract.

<p>How to specify — Select the Model Number from above.</p>	<p><i>1st Option:</i> Cord Retainer Clip Color: Black only.</p>
--	--

P | 2 | 7

Examples: A870824 A870824CH GS870924 AAPACM2.P27

ALED17U

S Shippable by small-package carrier.

For specification information see pages 449-450.

Open Market / GSA SIN 33721



GSA SIN 33721

Description	Model	List Price
Wand™ LED Task Light (Silver or White)		
Freestanding LED Task Light	WANDFS <input type="checkbox"/>	\$ 509
Freestanding LED Task Light (Occupancy Sensor)	WANDFSOC <input type="checkbox"/>	\$ 724

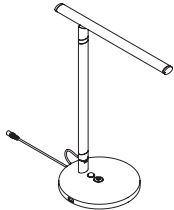

Freestanding LED Task light (Occupancy Sensor & Charging)	WANDFSUSB	\$ 754
---	-----------	--------



Splitty Task Light (Silver, White, or Black)		
Freestanding LED Task Light (Charging)	PRFTSKFS	\$ 690

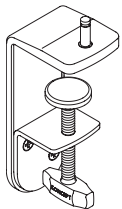

Clamp Mount (Silver only)	PRFTSKCL	\$ 80
---------------------------	----------	-------

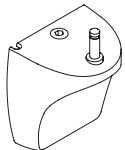

Tool Tile Mount (Silver only)	PRFTSKTR	\$ 80
-------------------------------	----------	-------

<p>How to specify — Select the Model Number from above.</p>	<p><i>1st Option:</i> Color (for Splitty): SVR Silver WHT White BLK Black</p> <p>(for Wand LED): SVR Silver WHT White</p>
--	--

Example: WANDFS.WHT

Shippable by small-package carrier.

For specification information see page 444.1.

GSA Reference Page

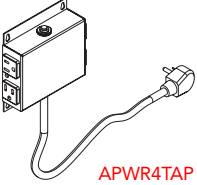
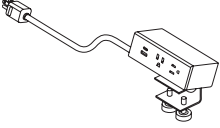
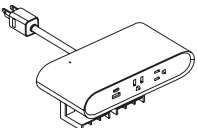
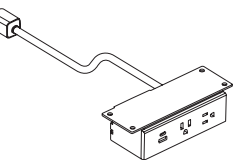
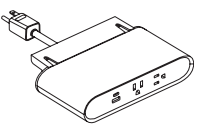
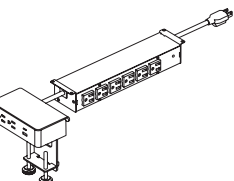
	Description	Model	List Price
 ACPWRMOD	Power/Data Module — Clamp On Worksurface 8"W x 7"D x 5½"H <ul style="list-style-type: none"> • 2 receptacles, 2 data terminals/blanks • 10' straight power cord only. UL Listed. • Available in Fog only, specify ACPWRMOD.FOG 	ACPWRMOD S	\$ 515
 APWR4TAP	Power/Data Module — Under Worksurface, Quad Tap 7"W x 12"D x 3"H <ul style="list-style-type: none"> • 4 receptacles • 10' Straight cord only, no specification needed. • Available in Black only, no specification needed. • Example: APWR4TAP 	APWR4TAP S	\$ 456
 APWRMOD.AC.S	Power Modules — Clamp On Worksurface, Rectangular 7½"W x 12¼"D x 5⅜"H <ul style="list-style-type: none"> • 2 receptacles, 1 USB-A, & 1 USB-C (AC) • Specify "QA" for 2 receptacles, 1 USB-A, & Qi wireless charging. • 10' Straight cord only (S). • Available in Snow (SNW) & Storm (STRM). • Example: APWRMOD.AC.S.SNW 	APWRMOD S	\$ 761
 ARNDPWRMOD.QA.S	Power Modules — Clamp On Worksurface, Round 8¼"W x 16"D x 4½"H <ul style="list-style-type: none"> • 2 receptacles, 1 USB-A, & 1 USB-C (AC) • Specify "QA" for 2 receptacles, 1 USB-A, 1 USB-C, & Qi wireless charging. • 9' Straight cord only (S). • Available in Snow (SNW) & Storm (STRM.) • Example: ARNDPWRMOD.AC.S.SNW 	ARNDPWRMOD S	\$ 713
 AUPWRMOD.AC.S	Power Module — Under Worksurface, Rectangular 7⅞"W x 9¼"D x 5⅜"H <ul style="list-style-type: none"> • 2 receptacles, 1 USB-A, & 1 USB-C (AC) • Power cord choices include a 10' Straight (S), 5' Interlink (I), 10' Hardwire (H), and 10' Chevron Fog & Storm Braided (B) cord. • Available in Snow (SNW), Storm (STRM), & Black (BLK). • Example: AUPWRMOD.AC.S.BLK 	AUPWRMOD S	\$ 761
 AURNDPWRMOD.AC.S	Power Module — Under Worksurface, Round 8¼"W x 16"D x 4½"H <ul style="list-style-type: none"> • 2 receptacles, 1 USB-A, & 1 USB-C (AC) • 9' Straight cord only (S). • Available in Snow (SNW), Storm (STRM), & Black (BLK). • Example: AURNDPWRMOD.AC.S.BLK 	AURNDPWRMOD S	\$ 713
 AABPWRMOD.AC.S	Power Module — Above/Below Worksurface 8¼"W x 16"D x 4½"H <ul style="list-style-type: none"> • Desktop unit includes 2 receptacles, 1 USB-A, & 1 USB-C (AC) • Under worksurface unit includes 6 receptacles. • Power cord choices include a 6' Straight cord (S) or Coiled cord (Q). • Desktop unit available in White (DWT) or Gray (DGY). • Example: AABPWRMOD.AC.S.DWT 	AABPWRMOD S	\$ 1234

<p>How to specify — Select the Model Number from above.</p>	<p>1st Option: Ports (Final port option if applicable): AC USB-A+C QA Wireless Charging with 1 USB-A port (+\$125)</p>	<p>2nd Option: Cord Type (Power Module cord type if applicable): S Straight Cord B Braided Chevron Fog & Storm Cord (+\$91) I Interlink Cord (+\$55) H Hardwire Cord (+\$106) Q Coiled Cord</p>	<p>3rd Option: Color Option (if applicable): SNW Snow STRM Storm BLK Black DWT White DGY Gray</p>
--	--	---	---

Example: APWRMOD.AC.S.SNW ACPWRMOD.FOG

S Shippable by small-package carrier.

For specification information see page 444.2.

GSA SIN 33721

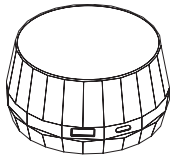

APWRPCK

Description	Model	List Price
Power/Data Module — Clamp On Worksurface		
5"W x 8"D x 4"H	APWRPCK <input type="checkbox"/>	\$ 693
<ul style="list-style-type: none"> • 1 USB-A & 1 USB-C port • 11' straight cord only, no specification needed. • Available in White & Silver only, no specification needed. • <i>Example: APWRPCK</i> 		

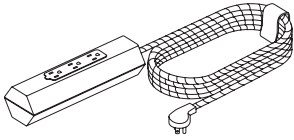

APWRSTRP

Power Strip — Sit-on-Surface, Wood		
4 3/8"W x 1 8/8"D x 4 3/8"H	APWRSTRP <input type="checkbox"/>	\$ 795
<ul style="list-style-type: none"> • 3 receptacles • 10' Braided cord in white nylon only, leather cord management strap included, no specification needed. • Available in wood finish only, no specification needed. • <i>Example: APWRSTRP</i> 		

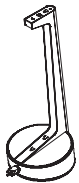

AVSTA3PWR

Vesta Mobile Power		
6 1/2"W x 10"D x 8"H	AVSTA3PWR <input type="checkbox"/>	\$ 2000
<ul style="list-style-type: none"> • 3 receptacles, 1 dual USB-A, 1 USB-C • 10' Straight retractable cord only, no specification needed. • Available in Snow, Storm, Black, and Fog. Separate finish options available for outside and inside of unit. • <i>Example: AVSTA3PWR.STRM.SNW</i> 		

<p>How to specify — Select the Model Number from above.</p> <p>_____ .</p>	<p><i>1st Option:</i> Color Option 1 (if applicable):</p> <p>FOG Fog SNW Snow STRM Storm BLK Black</p> <p>_____ .</p>	<p><i>2nd Option:</i> Color Option 2 (if applicable):</p> <p>FOG Fog SNW Snow STRM Storm BLK Black</p> <p>_____</p>
---	--	--

Example: AVSTA3PWR.STRM.SNW

Shippable by small-package carrier.

For specification information see pages 444.3-444.4.

GSA SIN 33721

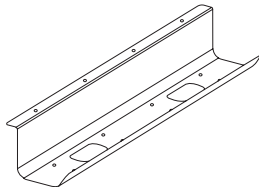

AJTRGH24

Description	Model	List Price		
		P1	P2	P3
Cable Management Trays				
24"W	AJTRGH24 S	\$ 123	N/A	N/A
36"W	AJTRGH36 S	\$ 147	N/A	N/A

- Available in 24" or 36" widths.
- Metal Cable Management Trays available in Black only, specify "P" for finish.
- Example: AJTRGH24.P

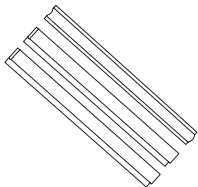

AWRSTRIP

Wire Management Strips/Channels				
	AWRSTRIP S	\$ 270	N/A	N/A

- Four wire management strips/channels in black only, no specification needed.
- Example: AWRSTRIP

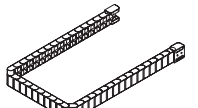

WKSWMC

Wire Management Chains				
36"	A9CLWMC S	\$ 357	N/A	N/A
58"	WKSWMC S	\$ 428	N/A	N/A

- Specify model A9CLWMC for 36" chain, specify model WKSWMC for 58" chain.
- A9CLWMC available in Black (E4), White (DW), or Silver (TI).
- WKSWMC available in Black only, no specification needed.
- Example: A9CLWMC.DW or WKSWMC

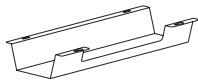

APWRTRGH17

Under Worksurface Troughs				
17"W	APWRTRGH17 S	\$ 108	N/A	N/A
36"W	APWRTRGH36 S	\$ 189	N/A	N/A

- Available in 17" or 36" widths.
- Under Worksurface Troughs available in Black only, no specification needed.
- Example: APWRTRGH17

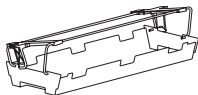

AFDTRGH20

Flip-Down Wire Management Trough				
20"W	AFDTRGH20 S	\$ 378	N/A	N/A
32"W	AFDTRGH32 S	\$ 429	N/A	N/A

- Available in 20" or 32" widths.
- Flip-Down Troughs available in Black only, no specification needed.
- Example: AFDTRGH20



AWIRECLT

Metal Wire Cleat				
	AWIRECLT S	\$ 129	\$ 142	\$ 148

- Available in standard metal paint finishes, see page 398 for options and specify desired finishes.
- Example: AWIRECLT.PJW

<p>How to specify —</p> <p>Select the Model Number from above.</p>	<p><i>1st Option:</i></p> <p>Paint (if applicable): See page 31 for finishes.</p> <p>Plastics (if applicable):</p> <p>DW White TI Silver E4 Black</p>
---	--

Examples: AJTRGH24.P A9CLWMC.DW

S Shippable by small-package carrier.

For specification information see pages 444.3-444.4.

GSA SIN 33721



ALEGCHASE26

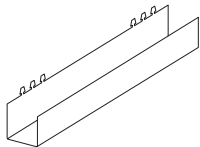

AMPCHASE

Description	Model	List Price		
		P1	P2	P3
O-Leg Chase				
26"H	ALEGCHASE26 S	\$ 174	\$ 191	\$ 200

- O-Leg Chase is 26"H.
- Available in standard metal paint finishes, see page 398 for options and specify desired finishes.
- Example: ALEGCHASE26.P27

Panel Mounted Wire Chase				
17"H	AMPCHASE S	\$ 147	\$ 162	\$ 169

- Panel Chase is 17"H.
- Available in standard metal paint finishes, see page 398 for options and specify desired finishes.
- Example: AMPCHASE.P27

EXTENSIONS

<p>How to specify — Select the Model Number from above.</p>	<p><i>1st Option:</i> Paint (if applicable): See page 398 for finishes.</p> <p>Plastics (if applicable): DW White TI Silver E4 Black</p>
--	---

Examples: ALEGCHASE26.P27

S Shippable by small-package carrier.

For specification information see pages 444.4-444.5.

GSA SIN 33721

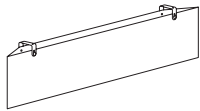

APWRMODEST36

Description	Model	List Price	
		A	B
Fabric Power Modesty			
	APWRMODEST36 <input type="checkbox"/>	\$ 1162	\$ 1196
	APWRMODEST48 <input type="checkbox"/>	\$ 1258	\$ 1297

- Available in ApPOINT, Binary, Centurion, Noble, Reflections, Disperse, and Spin panel fabric series.
- Specify desired fabric.
- *Example: APWRMODEST36.NBLE16*

How to specify —
Select the Model Number from above.

--	--	--

Example: APWRMODEST36.NBLE16

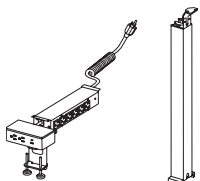

AHATPWRMOD2S or AHATPWRMOD3S

Description	Model	List Price		
		P1	P2	P3
Metal Telescoping HAT Wire Management				
	AHATPWRMOD2S <input type="checkbox"/>	\$ 1614	\$ 1654	\$ 1675
	AHATPWRMOD3S <input type="checkbox"/>	\$ 1646	\$ 1690	\$ 1711

- AHATPWRMOD2S pairs with 2-stage HAT bases.
- AHATPWRMOD3S pairs with 3-stage HAT bases.
- Desktop power module comes with 2 receptacles, 1 USB-A, and 1 USB-C port only, specify “AC” for this power configuration.
- Desktop power module available in White (DWT) or Gray (DGY) finishes, specify desired finish.
- Under worksurface power strip comes with 6 receptacles and is available in Black only, no specification needed.
- Metal Telescoping Chase available in the same paint finishes as Altitude HAT bases, specify desired paint finish.
- *Example: AHATPWRMOD2S.AC.DWT.PJW*

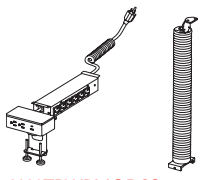

AHATPWRMOD2S or AHATPWRMOD3S

Fabric HAT Wire Management		AHATPWRMODF <input type="checkbox"/>	\$ 1476	\$ 1503	\$ 1516
-----------------------------------	--	--------------------------------------	---------	---------	---------

- AHATPWRMODF pairs with 2-stage and 3-stage HAT bases.
- Desktop power module comes with 2 receptacles, 1 USB-A, and 1 USB-C port only, specify “AC” for this power configuration.
- Desktop power module available in White (DWT) or Gray (DGY) finishes, specify desired finish.
- Under worksurface power strip comes with 6 receptacles and is available in Black only, no specification needed.
- Fabric HAT Chase available in three fabric finishes of Light (LGT), Medium (MDD), and Dark (DRK), specify desired fabric finish.
- Fabric HAT mounting brackets available in the same paint finishes as Altitude HAT bases, specify desired paint finish.
- *Example: AHATPWRMODF.AC.DGY.LGT.PR5*

How to specify —
Select the Model Number from above.

--	--	--	--

Example: AHATPWRMOD3S.AC.DWT.P8C

Example: AHATPWRMODF.AC.DGY.LGT.PR5

Shippable by small-package carrier.

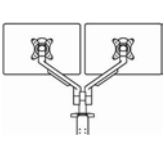
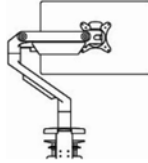
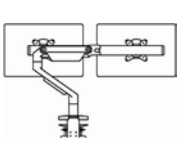
PIVOT MONITOR ARMS	Standard Dynamic Single	Standard Dynamic Dual	Heavy Duty Dynamic Single	Heavy Duty Dynamic Dual with Crossbar
Allsteel Model:	AMASTS	AMASD	AMASHD	AMADHD
				
Features:				
Price	\$488	\$983	\$838	\$1160
Colors	Black and Silver	Black and Silver	Black and Silver	Black and Silver
Monitor Rotation	180°	180°	180°	180°
Monitor Extension	18.75"	18.26"	20.75"	23"
Monitor Tilt Adjustment	+25°/-25°	+25°/-25°	+25°/-25°	+25°/-25°
Arm Height Adjustment	8.4" to 19"	9.6" to 20.1"	8.5" to 20"	8.5" to 20"
Weight Capacity	6.2 to 17 lbs.	6.2 to 17 lbs. per Arm	8 to 35 lbs.	17.5 lbs. per VESA Plate
Mounting Option	Grommet and Clamp Mounts	Grommet and Clamp Mounts	Grommet and Clamp Mounts	Grommet and Clamp Mounts
360° Lockout Feature	Yes	Yes	Yes	Yes
VESA Compatibility	75mm and 100mm	75mm and 100mm	75mm and 100mm	75mm and 100mm
Pole Height	N/A	N/A	N/A	N/A
Maximum Width per Monitor*	N/A	25"	N/A	25"
Worksurface Clamp Requirements	¾" to 2" Thick	¾" to 2" Thick	¾" to 2" Thick	¾" to 2" Thick
Worksurface Grommet Clamp Requirements	¾" to 2" Thick/Hole Diameter ⅜" to 2"	¾" to 2" Thick/Hole Diameter ⅜" to 2"	¾" to 2" Thick/Hole Diameter ⅜" to 2"	¾" to 2" Thick/Hole Diameter ⅜" to 2"
Environmental Info	94% Recycled Content	94% Recycled Content	94% Recycled Content	94% Recycled Content

*Use of APACSM Slider Model will allow for wider monitor capabilities

Pivot Standard Weight Monitor Arms

- Adaptable and adjustable to user preference the Pivot monitor arm offers a slim and refined design coupled with easy fingertip adjustment.
- Multiple points of adjustment including 360 degree swivel with optional 180 degree lockout, 18.75" extension, and 10" of height adjustment.
- Monitor tilts +25/-25 degrees.
- Standard weight arms utilize a tension spring that allows for effortless adjustment of monitors to proper ergonomic positions.
- Tension adjustment at multiple points allows for proper adjustment for monitors weight between 6-17 lbs.
- Model includes grommet and worksurface mounting options.
- Desk clamp mounts require ¾" – 2" thick surfaces; grommet mount requires hole diameter of ⅜" to 2" wide and accommodates up to 2" thick surfaces.
- Integrated cable management included with each model. Black models ship with all black cable management pieces, Silver models ship with grey wire management but optional white pieces ship in the box and can be installed on site.
- Dual monitor arm supports up to 25" wide monitors. Wider monitors may require use of optional slider mount model.
- Pivot arms are VESA 75mm and 100mm compatible.
- Quick release feature simplifies monitor installation and changes.

Pivot Slider Mount

- Provides 11.8" of horizontal movement.
- Allows for wider monitors to be used on dual monitor arms and sit flush side by side.
- Not compatible with Pivot Heavy Duty Series.

Pivot Heavy Duty Series

- Adaptable and adjustable to user preference the Pivot monitor arm offers a slim and refined design coupled with easy fingertip adjustment.
- Multiple points of adjustment including 360 degree swivel with optional 180 degree lockout, 20.75" extension, and 12" of height adjustment.
- Monitor tilts +25/-25 degrees.
- Tension adjustment at multiple points allows for proper adjustment for monitors weight between 8-35 lbs.
- Model includes grommet and worksurface mounting options.
- Desk clamp mounts require ¾" – 2" thick surfaces; grommet mount requires hole diameter of ⅜" to 2" wide and accommodates up to 2" thick surfaces.
- Integrated cable management included with each model. Black models ship with all black cable management pieces, Silver models ship with grey wire management but optional white pieces ship in the box and can be installed on site.
- Dual monitor arm supports up to 2 monitors weight 4-17.5 lbs each.
- Pivot arms are VESA 75mm and 100mm compatible.
- Quick release feature simplifies monitor installation and changes.

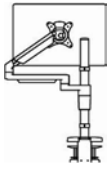
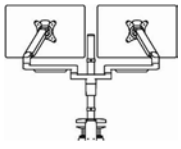
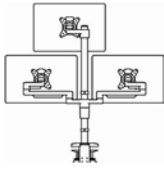
PIVOT MONITOR ARMS	Dynamic Single Post	Dynamic Dual Post	Triple Fixed Post
Allsteel Model:	APASD	APADD	APATF
			
Features:			
Price	\$660	\$923	\$1166
Colors	Silver	Silver	Silver
Monitor Rotation	180°	180°	180°
Monitor Extension	21"	21"	23"
Monitor Tilt Adjustment	+25°/-25°	+25°/-25°	+25°/-25°
Arm Height Adjustment	10.6"	10.6"	N/A
Weight Capacity	6.2 to 17 lbs.	6.2 to 17 lbs. per Arm	17 lbs. per arm
Mounting Option	Grommet and Clamp Mounts	Grommet and Clamp Mounts	Grommet and Clamp Mounts
360° Lockout Feature	Yes	Yes	Yes
VESA Compatibility	75mm and 100mm	75mm and 100mm	75mm and 100mm
Pole Height	17.7"	17.7"	27.5"
Maximum Width per Monitor*	25"	25"	25"
Worksurface Clamp Requirements	7/8" to 2" Thick	7/8" to 2" Thick	7/8" to 2" Thick
Worksurface Grommet Clamp Requirements	7/8" to 2" Thick/Hole Diameter 3/16" to 2"	7/8" to 2" Thick/Hole Diameter 3/16" to 2"	7/8" to 2" Thick/Hole Diameter 3/16" to 2"
Environmental Info	94% Recycled Content	94% Recycled Content	94% Recycled Content

*Use of APACSM Slider Model will allow for wider monitor capabilities

Pivot Post Series

- Adaptable and adjustable to user preference the Pivot monitor arm offers a slim and refined design coupled with easy fingertip adjustment.
- Multiple points of adjustment including 360 degree swivel with 21" extension and 10.6" of height adjustment.
- Monitor tilts +25/-25 degrees.
- Tension adjustment at multiple points allows for proper adjustment for monitors weight between 6.5-17 lbs per arm.
- Model includes grommet and worksurface mounting options.
- Desk clamp mounts require 7/8" – 2" thick surfaces; grommet mount requires hole diameter of 3/16" to 2" wide and accommodates up to 2" thick surfaces.
- Integrated cable management included with each model. Silver color option with grey wire management only.
- Dual monitor arm supports up to 25" wide monitors. Wider monitors may require use of optional slider mount model.
- Single and dual models have a post height of 17.7"; Triple monitor model has a post height of 27.5".
- Pivot arms are VESA 75mm and 100mm compatible.
- Quick release feature simplifies monitor installation and changes.

Pivot Counterweight Kit

- Counterweight Kit to be used with monitors weighing less than 6 lbs.
- Gray color only.
- Counterweight weighs 1 lb. 6 oz.

Pivot Conversion Kits

- Kit allows user to transform single monitor arm (Standard, Heavy Duty, or Post) into Dual Arm configuration
- Available in black and silver, Post arm only available in silver
- Required wire management included
- Once assembled, will aesthetically emulate dual configuration of chosen arm

Accessories — Pivot Monitor Arms

Pivot

For specification information see pages 454-455.

GSA SIN PENDING, GSA SIN 33721

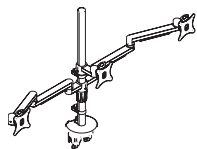
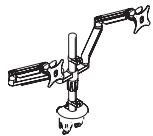
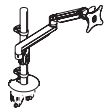
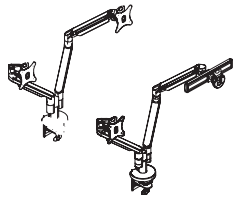
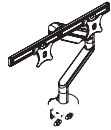

Description	Model	List Price
Pivot Monitor Arms		
Dynamic Single Monitor - Standard Weight	AMASTS <input type="checkbox"/>	\$ 488
Dynamic Single Monitor - Standard Weight for GSA *Silver Only Open for order Fall 2020 – GSA SIN 33721.	AMASTS-G	\$ 576
Dynamic Single Monitor - Heavy Weight	AMASHD <input type="checkbox"/>	\$ 838
Dynamic Dual Monitor with Crossbar	AMADHD <input type="checkbox"/>	\$ 1160
Dynamic Dual Monitor - Standard Weight	AMASD <input type="checkbox"/>	\$ 983
Dynamic Dual Monitor - Standard Weight for GSA *Silver Only **Slider Mount included. Open for order Fall 2020 – GSA SIN 33721.	AMASD-G	\$ 1048
Single Dynamic Post Arm *Silver Only	APASD <input type="checkbox"/>	\$ 660
Double Dynamic Post Arm *Silver Only	APADD <input type="checkbox"/>	\$ 923
Triple Fixed Post Mount *Silver Only	APATF <input type="checkbox"/>	\$ 1166

How to specify —
Select the
Model Number
from above.

1st Option:
Select the Color:
SVR Silver
BLK Black

A | | | | | .

| | | |

Example: AMADHD.BLK

Shippable by small-package carrier.

Accessories — Pivot Monitor Arms

Pivot

For specification information see pages [454-455](#).

Open Market



Description	Model	List Price
Pivot Monitor Arms		
Monitor Arm Sliding Mount	APACSM <input type="checkbox"/>	\$ 233

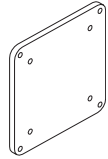

Monitor Arm Counterweight	APACW <input type="checkbox"/>	\$ 55
---------------------------	--------------------------------	-------

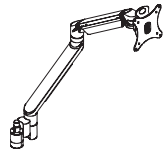

Pivot Monitor Arm Standard Single Conversion Kit	AMASTSCK	\$ 546
--	----------	--------

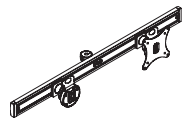

Pivot Monitor Arm Heavy Duty Single Conversion Kit	AMASHDCK	\$ 477
--	----------	--------

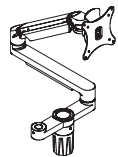

Pivot Single Post Arm Conversion Kit	APASDCK	\$ 695
* Silver Only		

How to specify —
Select the Model Number from above.

1st Option:
Select the Color:
SVR Silver
BLK Black

A | | | | | .

| | | |

Example:

TOP & BASE PAINT FINISHES

GRADE P1

Black	P27
Black	P71
Brownstone	P7D
Bungalow	P7C
Cinder	P7Q
Cove	P096
Designer White	PJW
Dune	P094
Flint	P02
Fossil	P28
Harbor	P097
Loft	P7B
Muslin	P4J
Parchment	P93
Pebble	P8R
Pewter	P8D
Sage	P095
Salt	P8C
Titanium	P8T/T

GRADE P2

Champagne Metallic	PR5
Designer White High Gloss 65	P8W
Gunmetal Metallic	PR3
Night Bronze	P8B
Platinum Metallic	PR2
Pyrite	PJE
Silver	PR6
Solar Black	P8X

GRADE P3

Atom	P8S
Blossom	P8K
Bullseye	PJF
Cabernet	P7T
Conifer	P8H
Ember	P8P
Ion	P8N
Iris	P8J
Krypton	P8F
Regatta	P8M
Succulent	P8A

GRADE P4

Polished Aluminum	PAL/P
-------------------	-------

LAMINATES

GRADE L1

SOLID COLORS

Black	P
Brownstone	LM13
Bungalow	LM12
Designer White	LDW1
Flint	LM16
Fossil Shale	LEH1
Loft	LM11
Muslin	LM15
Titanium	LTI1

ABSTRACT

Ash	LT3B
Handspun Pearl	LAHP
Handspun Dove	LAHD
Handspun Slate	LAHS
Handspun Chestnut	LAHC
Silver Mesh	LT8D

WOODGRAIN

Belair	LWBA
Bourbon Cherry	H
Field Elm	LWFE
Florence Walnut	LFW1
Kingswood Walnut	LK1I
Natural Maple	LWD
NeoWalnut	LNU1
Pinnacle	PINC
Shaker Cherry	LW7C

GRADE L2

Beigewood	LWBE
Fawn Cypress	LFC1
Lowell Ash	LLA1
Mangalore Mango	LMM1
Natural Recon	LNR1
Phantom Charcoal	LPC1
Phantom Ecu	LPE1
Portico Teak	LPT1
Skyline Walnut	LSW1
Veranda Teak	LVT1

GRADE L3

Natural Walnut	LWNW
----------------	------

LAMINATE EDGE COLORS

Beigewood	DE
Belair	BA
Black	E4
Bourbon Cherry	H
Brownstone	EY
Bungalow	EX
Designer White	DW
Fawn Cypress	FC
Field Elm	FE
Flint	E9
Florence Walnut	FW
Fossil	EH
Kingswood Walnut	KI
Loft	EV
Lowell Ash	DL
Mangalore Mango	MM
Muslin	EU
Natural Maple	DD
Natural Recon	NR
Natural Walnut	DN
NeoWalnut	NU
Parchment	EN
Phantom Charcoal	PC
Phantom Ecu	PE
Pinnacle	PI
Portico Teak	DP
Shaker Cherry	DF
Skyline Walnut	SW
Titanium	TI
Veranda Teak	VT

STRATAWOOD VENEERS

GRADE V2

CHERRY

Cinnamon/Biltmore Cherry	SC260
Lowell Ash	SC394
Clear Cherry	SC700
Light Cherry	SC701
Shaker Cherry	SC774
Burnished Cherry	SC777

MAPLE

Field Elm	SE599
Clear Maple	SE800
Harvest Maple	SE856
Beigewood	SE878
Phantom Ecu	SE912
Belair	SE934

OAK

Clear Oak	SEF300
Dark Rift Cut Oak	SEF331

SILVER OAK

Clear	SB100
Portico Teak	SB150

WALNUT

Florence Walnut	ST579
Light Walnut	ST601
Skyline Walnut	ST625
Pinnacle Walnut	ST679
Sumatra Walnut	ST693

NATURAL VENEERS — FLAT CUT

GRADE V2

CHERRY

Cinnamon/Biltmore Cherry	NC260
Lowell Ash	NC394
Medium Red Cherry	NC512
Light Cherry	NC701
Shaker Cherry	NC774
Burnished Cherry	NC777

MAPLE

Clear Maple	NE800
Harvest Maple	NE856

WALNUT

Ebony Walnut	NT509
Florence Walnut	NT579
Light Walnut	NT601
Skyline Walnut	NT625
Nutmeg Walnut	NT629
Pinnacle Walnut	NT679
Sumatra Walnut	NT693

NATURAL VENEERS — RIFT CUT

GRADE V3

Fawn Cypress Rift Cut Oak	RF108
Light Rift Cut Oak	RF301
Dark Rift Cut Oak	RF331
Phantom Ecu Rift Cut Oak	RF912

Note: Refer to individual product pages for upcharges.

FSC Certified Wood at Allsteel

See page 459 for more information.

Aware Collection

Allsteel designed a flexible and comprehensive collection of active learning furniture. The Aware Collection consists of buffet and recycle credenzas, mobile and wall-hung marker boards, and unique shaped table tops that offer a timeless design. Look to the Aware Collection brochure for full details.

Materials and Edge Treatments

Aware tables offer functional flexibility and aesthetic versatility to provide one, simple solution for the entire office. The broad selection of materials and finishes ensure that the tables look beautiful in any application.

Laminate Edges

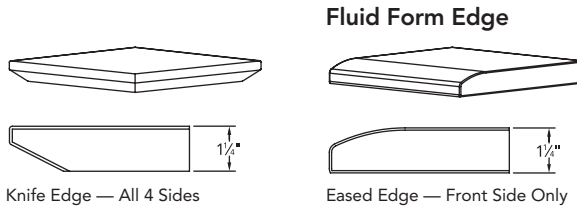
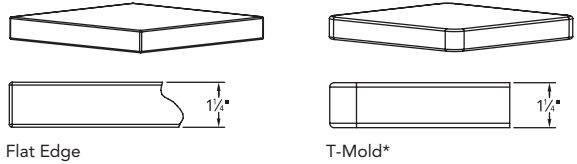

Veneer Edge

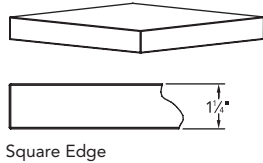

T-mold tops will have a 3/4" radius on all corners.

24"D or 30"D Knife edge rectangle tops feature a shaped edge on all four sides. Eased edge tops feature a shaped edge on one side.

Allsteel Fluid Form is an advanced surface material that offers a seamless solid base layer with protective coating. Its seamless 3-dimensional edge profile eliminates the need for edge banding or T-mold making it ideal for horizontal surfaces.

FSC Certified Wood at Allsteel

Forest Stewardship Council® (FSC) certification promotes the sustainable harvesting of forests worldwide. The FSC program sets requirements for the management of the forest and for everyone that handles the wood from forest to product. Allsteel has an FSC Chain of Custody and can provide FSC certified products to customers who choose to order them. FSC products can contribute to LEED projects. To order FSC products, the "FSC" option must be selected in the model code at time of order. For more information, please contact Customer Support at 888-255-7833.

FSC Trademark License code FSC-C014704.

Aware Table Options		Top Finish and Edge Options				
		Laminate				Veneer
Leg Options		Flat	T-Mold	Knife	Eased	Square
T-Leg	Fixed	X	X		X	X
	Nesting	X	X		X	X
	Folding	X	X		X	
V-Leg	Fixed	X	X	X	X	X
	Nesting	X	X		X	X

Aware Table Sizes	Table Top Sizes*			
Style of Legs	18"D	24"D	30"D	36"D
T-Leg – Folding	60"-72"W	60"-72"W	60"-72"W	
T-Leg – Fixed or Nesting	48"-72"W	36"-96"W	36"-96"W	48"-72"W
V-Leg – Fixed or Nesting		36"-96"W	36"-96"W	

*Widths are available in 6" or 12" increments of range listed.

Aware Standing Height Table Sizes	Table Top Sizes*	
Style of Legs	24"D	30"D
T-Leg Fixed		54"-84"W
V-Leg Fixed	54"-84"W	

*Widths are available in 6" or 12" increments of range listed.

Table Capacities

Table Tops	Seating Capacity	Table Tops	Seating Capacity
18" x 48" Rectangle	2	24" x 36" Rectangle	1
18" x 54" Rectangle	2	24" x 42" Rectangle	1
18" x 60" Rectangle	2	24" x 48" Rectangle	2
18" x 66" Rectangle	2	24" x 54" Rectangle	2
18" x 72" Rectangle	3	24" x 60" Rectangle	2
		24" x 66" Rectangle	2
		24" x 72" Rectangle	3

Table Tops	Seating Capacity	Table Tops	Seating Capacity
30" x 36" Rectangle	2	36" x 48" Rectangle	4
30" x 42" Rectangle	2	36" x 54" Rectangle	4
30" x 48" Rectangle	4	36" x 60" Rectangle	4
30" x 54" Rectangle	4	36" x 66" Rectangle	6
30" x 60" Rectangle	4	36" x 72" Rectangle	6
30" x 66" Rectangle	4		
30" x 72" Rectangle	6		
30" x 84" Rectangle	6		
30" x 96" Rectangle	8		

Fixed

Nesting

Folding

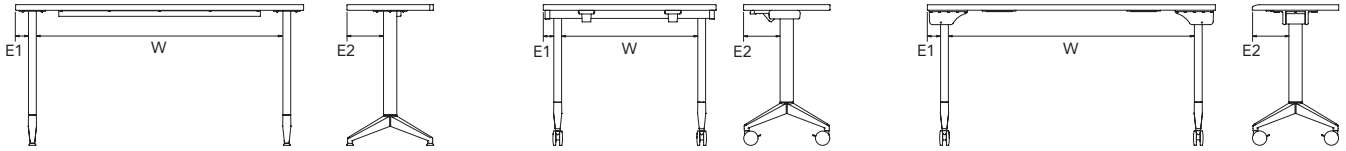

Leg Type:	T-Leg Fixed			T-Leg Nesting			V-Leg Fixed or Nesting			T-Leg Folding		
Dimension:	E1	W	E2	E1	W	E2	E1	W	E2	E1	W	E2
Aware Table Rectangle Top Size:	Edge of Table to outside of leg	Between Legs	Edge of table to the outside of leg	Edge of Table to outside of leg	Between Legs	Edge of table to the outside of leg	Edge of Table to outside of leg	Between Legs	Edge of table to the outside of leg	Edge of Table to outside of leg	Between Legs	Edge of table to the outside of leg
18" x 48"	2 5/8"	39 3/8"	7 3/8"	2 1/8"	40 3/8"	7 3/8"	-	-	-	-	-	-
18" x 54"	2 5/8"	45 3/8"	7 3/8"	2 1/8"	46 3/8"	7 3/8"	-	-	-	-	-	-
18" x 60"	2 5/8"	51 3/8"	7 3/8"	2 1/8"	52 3/8"	7 3/8"	-	-	-	2 3/4"	51 1/4"	7 3/8"
18" x 66"	2 5/8"	57 3/8"	7 3/8"	2 1/8"	58 3/8"	7 3/8"	-	-	-	2 3/4"	57 1/4"	7 3/8"
18" x 72"	2 5/8"	63 3/8"	7 3/8"	2 1/8"	64 3/8"	7 3/8"	-	-	-	2 3/4"	63 1/4"	7 3/8"
24" x 36"	2 5/8"	27 3/8"	10 3/8"	2 1/8"	28 3/8"	10 3/8"	5 1/8"	22 3/8"	10 3/8"	-	-	-
24" x 42"	2 5/8"	33 3/8"	10 3/8"	2 1/8"	34 3/8"	10 3/8"	5 1/8"	28 3/8"	10 3/8"	-	-	-
24" x 48"	2 5/8"	39 3/8"	10 3/8"	2 1/8"	40 3/8"	10 3/8"	5 1/8"	34 3/8"	10 3/8"	-	-	-
24" x 54"	2 5/8"	45 3/8"	10 3/8"	2 1/8"	46 3/8"	10 3/8"	5 1/8"	40 3/8"	10 3/8"	-	-	-
24" x 60"	2 5/8"	51 3/8"	10 3/8"	2 1/8"	52 3/8"	10 3/8"	5 1/8"	46 3/8"	10 3/8"	2 3/4"	51 1/4"	10 3/8"
24" x 66"	2 5/8"	57 3/8"	10 3/8"	2 1/8"	58 3/8"	10 3/8"	5 1/8"	52 3/8"	10 3/8"	2 3/4"	57 1/4"	10 3/8"
24" x 72"	2 5/8"	63 3/8"	10 3/8"	2 1/8"	64 3/8"	10 3/8"	5 1/8"	58 3/8"	10 3/8"	2 3/4"	63 1/4"	10 3/8"
24" x 84"	2 5/8"	75 3/8"	10 3/8"	2 1/8"	76 3/8"	10 3/8"	5 1/8"	70 3/8"	10 3/8"	-	-	-
24" x 96"	2 5/8"	87 3/8"	10 3/8"	2 1/8"	88 3/8"	10 3/8"	5 1/8"	82 3/8"	10 3/8"	-	-	-
30" x 36"	2 5/8"	27 3/8"	13 3/8"	2 1/8"	28 3/8"	13 3/8"	5 1/8"	22 3/8"	13 3/8"	-	-	-
30" x 42"	2 5/8"	33 3/8"	13 3/8"	2 1/8"	34 3/8"	13 3/8"	5 1/8"	28 3/8"	13 3/8"	-	-	-
30" x 48"	2 5/8"	39 3/8"	13 3/8"	2 1/8"	40 3/8"	13 3/8"	5 1/8"	34 3/8"	13 3/8"	-	-	-
30" x 54"	2 5/8"	45 3/8"	13 3/8"	2 1/8"	46 3/8"	13 3/8"	5 1/8"	40 3/8"	13 3/8"	-	-	-
30" x 60"	2 5/8"	51 3/8"	13 3/8"	2 1/8"	52 3/8"	13 3/8"	5 1/8"	46 3/8"	13 3/8"	2 3/4"	51 1/4"	13 3/8"
30" x 66"	2 5/8"	57 3/8"	13 3/8"	2 1/8"	58 3/8"	13 3/8"	5 1/8"	52 3/8"	13 3/8"	2 3/4"	57 1/4"	13 3/8"
30" x 72"	2 5/8"	63 3/8"	13 3/8"	2 1/8"	64 3/8"	13 3/8"	5 1/8"	58 3/8"	13 3/8"	2 3/4"	63 1/4"	13 3/8"
30" x 84"	2 5/8"	75 3/8"	13 3/8"	2 1/8"	76 3/8"	13 3/8"	5 1/8"	70 3/8"	13 3/8"	-	-	-
30" x 96"	2 5/8"	87 3/8"	13 3/8"	2 1/8"	88 3/8"	13 3/8"	5 1/8"	82 3/8"	13 3/8"	-	-	-
36" x 48"	2 5/8"	39 3/8"	16 3/8"	2 1/8"	40 3/8"	16 3/8"	-	-	-	-	-	-
36" x 54"	2 5/8"	45 3/8"	16 3/8"	2 1/8"	46 3/8"	16 3/8"	-	-	-	-	-	-
36" x 60"	2 5/8"	51 3/8"	16 3/8"	2 1/8"	52 3/8"	16 3/8"	-	-	-	-	-	-
36" x 66"	2 5/8"	57 3/8"	16 3/8"	2 1/8"	58 3/8"	16 3/8"	-	-	-	-	-	-
36" x 72"	2 5/8"	63 3/8"	16 3/8"	2 1/8"	64 3/8"	16 3/8"	-	-	-	-	-	-

Space Requirement Guidelines

Tables:

- 24"-30"W per person depending on materials
- 4' between tables
- Breakout Rooms 10-12 sq. ft. per person
- Computer Training 20 sq. ft. per person

Space Savings With Nesting Tables

1. Start with table size in nested position:
 - 18"D table = 18"D
 - 24"D table = 24"D
 - 30"D table = 30"D
 - 36"D table = 36"D
2. Add 7¾"D for each additional nested table (no additional required if modesty panel is attached).
 - Example: A 24"D table in nested position is 24"D.
 - Add 9 additional nested tables
 - (9 x = 69¾"D).
 - Depth requirement for ten nested tables is 93¾"D.
3. Add 1½"W for each additional nested T-Leg table to the width of the widest table. Maximum 6" additional width. (3"W for V-Leg; maximum 12" additional width)
 - Example: Ten 72"W tables are nested.
 - 72" + 6" = 78"W
4. Total space for 10 nested tables above is 93¾"D x 78"W.
5. Space saved by nesting is over ___ square feet.
6. Table height of Aware nested tables:
 - 18"D table = 37⅞"H nested
 - 24"D table = 41⅞"H nested
 - 30"D table = 44⅞"H nested
 - 36"D table = 47⅞"H nested

Folded Tables Standard — Side View

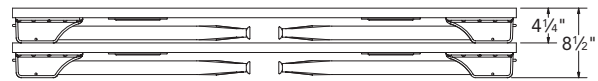

T-Leg Nested — Top View

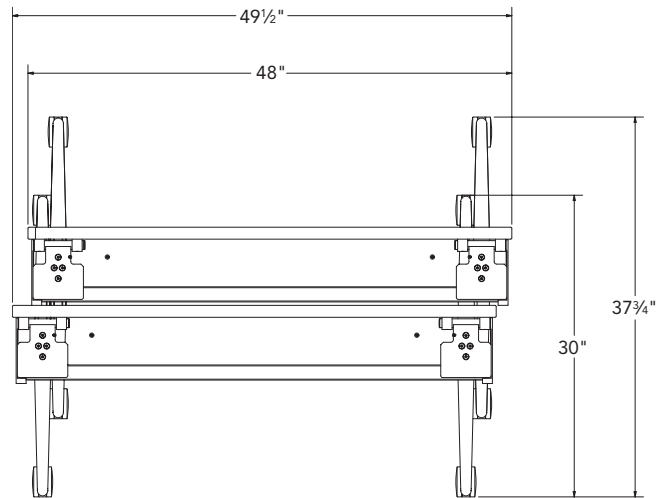

V-Leg Nested — Top View

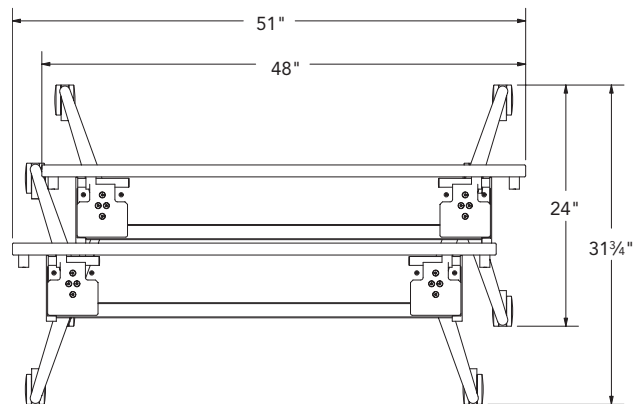

POWER/DATA PORT CUTOUTS FOR AWARE TABLES

When specifying Aware tables, grommets or power/data port cutouts may be specified for power/data. Grommets are available in plastic or oval (shown at right). If cutouts are specified, a pop-up power/data port must be specified for use in the cutout. Cutouts are unfinished and cannot be used as grommet openings. The chart below indicates which grommet or cutout options are available on Aware tables.

- | Code | Position |
|------------|---|
| AGO | No grommets or cutouts. |
| AG1 | Single grommet, centered left to right, 2" from back of surface. |
| AG2 | Pair of grommets, approximately 3" in from each side, 2" from back of surface. |
| ATC | One cutout for Pop-up Power, centered left-to-right and front-to-back. Only on 30"D and 36"D tables. Do not specify on folding or nesting tables. |
| ATE | One cutout for Pop-up Power, centered left-to-right, 2" in from back of surface. |

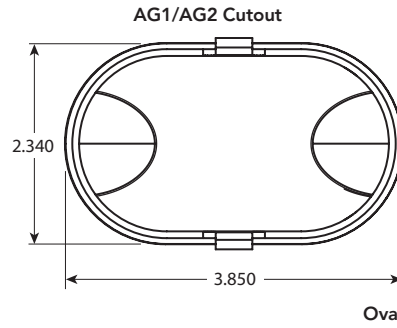

AG1 and AG2 Grommet Color Offering	
Designer White	DW
Black	E4
Flint	E9
Fossil	EH
Parchment	EN
Muslin	EU
Loft	EV
Brownstone	EY
Titanium	TI

Dimension	AGO	AG1	AG2	ATC	ATE
18"D x 48"W	•	•	•		•
18"D x 54"W	•	•	•		•
18"D x 60"W	•	•	•		•
18"D x 66"W	•	•	•		•
18"D x 72"W	•	•	•		•
24"D x 36"W	•	•	•		•
24"D x 42"W	•	•	•		•
24"D x 48"W	•	•	•		•
24"D x 54"W	•	•	•		•
24"D x 60"W	•	•	•		•
24"D x 66"W	•	•	•		•
24"D x 72"W	•	•	•		•
24"D x 84"W	•	•	•		•
24"D x 96"W	•	•	•		•
30"D x 36"W	•	•	•	•	•
30"D x 42"W	•	•	•	•	•
30"D x 48"W	•	•	•	•	•
30"D x 54"W	•	•	•	•	•
30"D x 60"W	•	•	•	•	•
30"D x 66"W	•	•	•	•	•
30"D x 72"W	•	•	•	•	•
30"D x 84"W	•	•	•	•	•
30"D x 96"W	•	•	•	•	•
36"D x 48"W	•	•	•	•	•
36"D x 54"W	•	•	•	•	•
36"D x 60"W	•	•	•	•	•
36"D x 66"W	•	•	•	•	•
36"D x 72"W	•	•	•	•	•

Grommet Locations

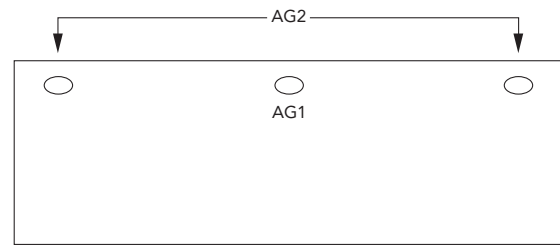

Cutout Locations

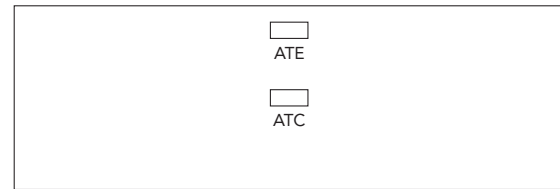

WIRE MANAGER CABLE CAPACITY

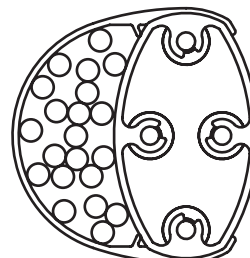

21 voice/data cables (.25" dia.) at 60% fill ratio

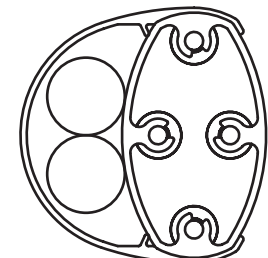

2 electrical infeed at 60% fill ratio

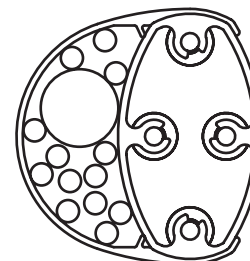

13 voice/data cables (.25" dia.) at 60% fill ratio

ELECTRICAL OPTIONS

Aware Tables offer three power options: Corded, Interlink IQ, or Hardwire. Installation and use of electrical systems, the number of receptacles used on a given circuit, and connections to the building power supply should be in compliance with all local and national electrical codes. Verify code requirements before ordering. Chicago requires hard wiring. Chicago and New York do not permit use of Interlink IQ components.

Corded

Corded models plug directly into an outlet. Corded modules cannot plug into other corded power modules. In order to plug into other units the unit would need to be hardwired. When routing corded models to a wall outlet, the maximum amount of cord that can be exposed outside of the furniture is 6 feet. (New York, check local code.)

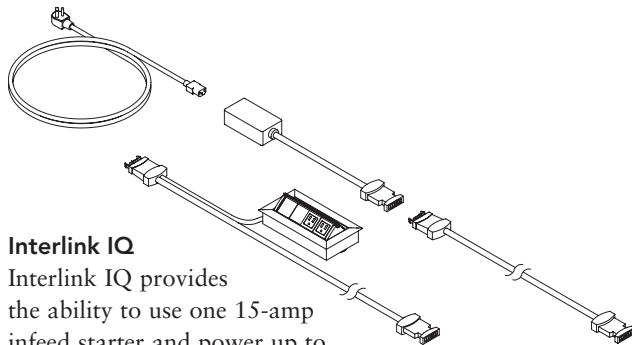
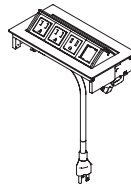

Interlink IQ

Interlink IQ provides the ability to use one 15-amp infeed starter and power up to 8 power modules (including jumpers) off of one infeed starter. Interlink IQ provides a visual indicator of system status. LED illuminates green when you are connected and ready to plug in. A red light indicates you have linked too many units. See page 462 for examples of multiple tables using Interlink IQ components.

Hardwire

Hardwire models are provided with 10' of sealtight cable. Customer must furnish junction boxes, conduit, and additional wire to be in compliance with local and national electrical codes.

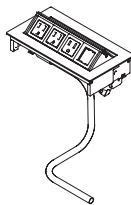

Wire Trough

Attach wire trough as needed to the underside of tables to support cords.

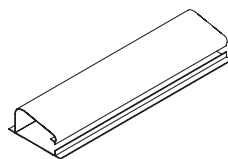

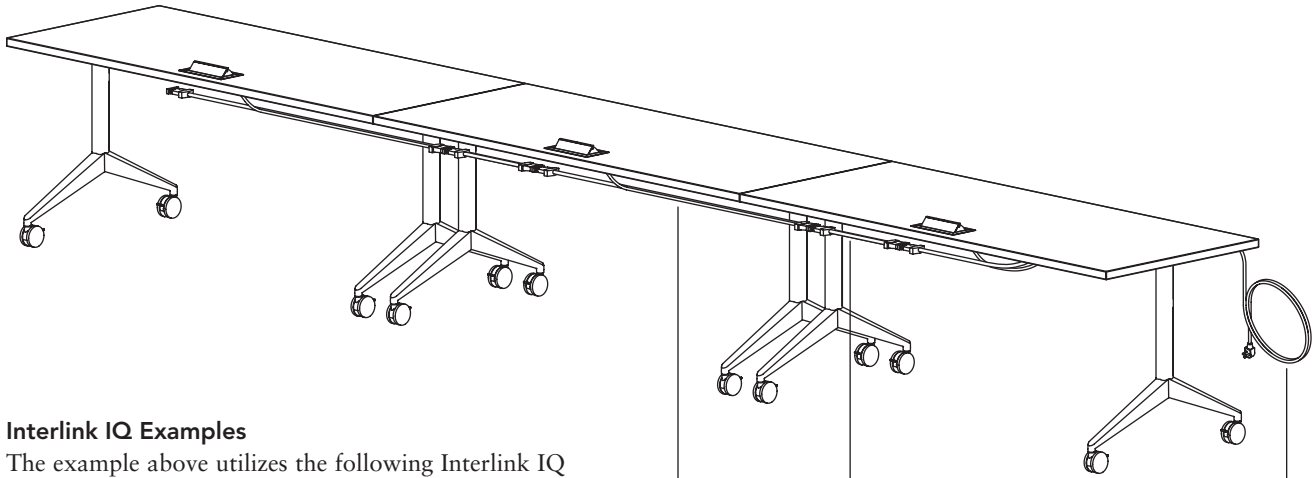

Interlink IQ Examples

The example above utilizes the following Interlink IQ components to power three 72"W Aware tables:

- 3 – Interlink IQ 60" Power Harnesses
model number: AW4QH60P
(provides two AC power receptacles per unit)
- 2 – Interlink IQ 36" Jumpers model number: AW4QJ36
- 1 – Interlink IQ Starter model number: AW4QBI

The example below utilizes the following Interlink IQ components to power five 72"W Aware tables:

- 5 – Interlink IQ 60" Power Harnesses model number:
AW4QH60P
(provides two AC power receptacles per unit)
- 2 – Interlink IQ 36" Jumpers model number: AW4QJ36
- 1 – Interlink IQ Starter model number: AW4QBI

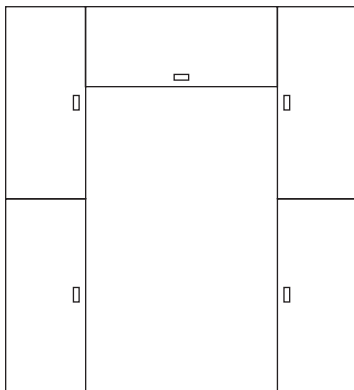

- Order folding legs separately — see options on page 466.
- Specify grommet location, type, and color — see page 462.
- Eased edge tops feature shaped edge on front side.
- Optional electrical components, wire trough, modesty panel, and ganging hardware ordered separately — see pages 483-486.

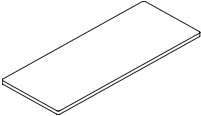

Description	Model	Ship Weight	Cubes	List Price			
				L1	L2	L3	FF
18"D Folding Table Tops							
60"W Laminate – Flat Edge	AW3LF1860F	52 <input type="checkbox"/>	4.6	\$ 656	\$ 681	\$ 703	—
60"W Laminate – T-Mold Edge	AW3LT1860F	36 <input type="checkbox"/>	4.6	\$ 656	\$ 681	\$ 703	—
60"W Fluid Form – Eased Edge	AW3FE1860F	52 <input type="checkbox"/>	4.6	—	—	—	\$ 864
66"W Laminate – Flat Edge	AW3LF1866F	57 <input type="checkbox"/>	5.0	\$ 740	\$ 769	\$ 792	—
66"W Laminate – T-Mold Edge	AW3LT1866F	44 <input type="checkbox"/>	5.0	\$ 740	\$ 769	\$ 792	—
66"W Fluid Form – Eased Edge	AW3FE1866F	57 <input type="checkbox"/>	5.0	—	—	—	\$ 982
72"W Laminate – Flat Edge	AW3LF1872F	62 <input type="checkbox"/>	5.5	\$ 767	\$ 796	\$ 821	—
72"W Laminate – T-Mold Edge	AW3LT1872F	52 <input type="checkbox"/>	5.5	\$ 767	\$ 796	\$ 821	—
72"W Fluid Form – Eased Edge	AW3FE1872F	62 <input type="checkbox"/>	5.5	—	—	—	\$ 1077
24"D Folding Table Tops							
60"W Laminate – Flat Edge	AW3LF2460F	53 <input type="checkbox"/>	5.9	\$ 717	\$ 745	\$ 767	—
60"W Laminate – T-Mold Edge	AW3LT2460F	53 <input type="checkbox"/>	5.9	\$ 717	\$ 745	\$ 767	—
60"W Fluid Form – Eased Edge	AW3FE2460F	53 <input type="checkbox"/>	5.9	—	—	—	\$ 878
66"W Laminate – Flat Edge	AW3LF2466F	64 <input type="checkbox"/>	6.4	\$ 767	\$ 796	\$ 821	—
66"W Laminate – T-Mold Edge	AW3LT2466F	64 <input type="checkbox"/>	6.4	\$ 767	\$ 796	\$ 821	—
66"W Fluid Form – Eased Edge	AW3FE2466F	64 <input type="checkbox"/>	6.4	—	—	—	\$ 1077
72"W Laminate – Flat Edge	AW3LF2472F	75 <input type="checkbox"/>	6.9	\$ 811	\$ 842	\$ 867	—
72"W Laminate – T-Mold Edge	AW3LT2472F	75 <input type="checkbox"/>	6.9	\$ 811	\$ 842	\$ 867	—
72"W Fluid Form – Eased Edge	AW3FE2472F	75 <input type="checkbox"/>	6.9	—	—	—	\$ 1273
30"D Folding Table Tops							
60"W Laminate – Flat Edge	AW3LF3060F	78 <input type="checkbox"/>	7.1	\$ 799	\$ 829	\$ 854	—
60"W Laminate – T-Mold Edge	AW3LT3060F	78 <input type="checkbox"/>	7.1	\$ 799	\$ 829	\$ 854	—
60"W Fluid Form – Eased Edge	AW3FE3060F	78 <input type="checkbox"/>	7.1	—	—	—	\$ 1029
66"W Laminate – Flat Edge	AW3LF3066F	86 <input type="checkbox"/>	7.7	\$ 858	\$ 890	\$ 918	—
66"W Laminate – T-Mold Edge	AW3LT3066F	86 <input type="checkbox"/>	7.7	\$ 858	\$ 890	\$ 918	—
66"W Fluid Form – Eased Edge	AW3FE3066F	86 <input type="checkbox"/>	7.7	—	—	—	\$ 1154
72"W Laminate – Flat Edge	AW3LF3072F	93 <input type="checkbox"/>	8.4	\$ 916	\$ 949	\$ 980	—
72"W Laminate – T-Mold Edge	AW3LT3072F	93 <input type="checkbox"/>	8.4	\$ 916	\$ 949	\$ 980	—
72"W Fluid Form – Eased Edge	AW3FE3072F	93 <input type="checkbox"/>	8.4	—	—	—	\$ 1281

<p>How to specify — Select the Model Number from above.</p> <p>Suffix: F for use with folding legs</p> <p>AW3 </p> <p> F .</p>	<p>1st Option: FSC Certified Wood:</p> <p>FSC Select for FSC Certified Wood X No FSC</p> <p> .</p>	<p>2nd Option: Laminate or Fluid Form:</p> <p>See inside front cover for finishes.</p> <p> .</p>	<p>3rd Option: Edge Color (Laminate only):</p> <p>See inside front cover for finishes.</p> <p> .</p>	<p>4th Option: Grommet or Cutout Location (see page 462):</p> <p>AG0 No Grommets AG1 Centered Oval (Add \$13) AG2 Pair Ovals (Add \$25) ATE Pop-up Power Cutout – Centered Side-to-Side, 2" from Back</p> <p>A </p>	<p>5th Option: Grommet Type (if applicable):</p> <p>P Oval Plastic</p> <p> </p>	<p>6th Option: Grommet Color:</p> <p>See page 462 for Oval grommet color offering.</p> <p> </p>
---	--	--	--	---	--	--

Examples: AW3LT1860F.X.LM13EY.AG2PEY AW3FE3072F.FSC.TF33.AG0 Shippable by small-package carrier.

- Order legs separately — see options on page 468. “T” suffix top for T-legs.
- Specify grommet location, type, and color — see page 462.
- Eased edge tops feature shaped edge on front side.
- Optional electrical components, wire trough, modesty panel, and ganging hardware ordered separately — see pages 483-486.

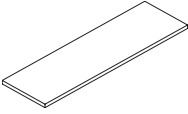

Description	Model	Ship Weight	Cubes	List Price			
				L1 or V2	L2 or V3	L3	FF
18"D Table Tops							
48"W Laminate – Flat Edge	AW3LF1848T	36	<input checked="" type="checkbox"/> 3.8	\$ 562	\$ 585	\$ 603	—
48"W Laminate – T-Mold Edge	AW3LT1848T	36	<input checked="" type="checkbox"/> 3.8	\$ 562	\$ 585	\$ 603	—
48"W Fluid Form – Eased Edge	AW3FE1848T	36	<input checked="" type="checkbox"/> 3.8	—	—	—	\$ 838
48"W Veneer – Square Edge	AW3VF1848T	36	<input checked="" type="checkbox"/> 3.8	\$ 2834	\$ 3092	—	—
<hr/>							
54"W Laminate – Flat Edge	AW3LF1854T	44	<input checked="" type="checkbox"/> 4.2	\$ 596	\$ 620	\$ 640	—
54"W Laminate – T-Mold Edge	AW3LT1854T	44	<input checked="" type="checkbox"/> 4.2	\$ 596	\$ 620	\$ 640	—
54"W Fluid Form – Eased Edge	AW3FE1854T	44	<input checked="" type="checkbox"/> 4.2	—	—	—	\$ 846
54"W Veneer – Square Edge	AW3VF1854T	44	<input checked="" type="checkbox"/> 4.2	\$ 2956	\$ 3225	—	—
<hr/>							
60"W Laminate – Flat Edge	AW3LF1860T (shown)	52	<input checked="" type="checkbox"/> 4.6	\$ 656	\$ 681	\$ 703	—
60"W Laminate – T-Mold Edge	AW3LT1860T	52	<input checked="" type="checkbox"/> 4.6	\$ 656	\$ 681	\$ 703	—
60"W Fluid Form – Eased Edge	AW3FE1860T	52	<input checked="" type="checkbox"/> 4.6	—	—	—	\$ 864
60"W Veneer – Square Edge	AW3VF1860T	52	<input checked="" type="checkbox"/> 4.6	\$ 3082	\$ 3362	—	—
<hr/>							
66"W Laminate – Flat Edge	AW3LF1866T	57	<input checked="" type="checkbox"/> 5.0	\$ 740	\$ 769	\$ 792	—
66"W Laminate – T-Mold Edge	AW3LT1866T	57	<input checked="" type="checkbox"/> 5.0	\$ 740	\$ 769	\$ 792	—
66"W Fluid Form – Eased Edge	AW3FE1866T	57	<input checked="" type="checkbox"/> 5.0	—	—	—	\$ 982
66"W Veneer – Square Edge	AW3VF1866T	57	<input checked="" type="checkbox"/> 5.0	\$ 3269	\$ 3566	—	—
<hr/>							
72"W Laminate – Flat Edge	AW3LF1872T	62	<input checked="" type="checkbox"/> 5.5	\$ 767	\$ 796	\$ 821	—
72"W Laminate – T-Mold Edge	AW3LT1872T	62	<input checked="" type="checkbox"/> 5.5	\$ 767	\$ 796	\$ 821	—
72"W Fluid Form – Eased Edge	AW3FE1872T	62	<input checked="" type="checkbox"/> 5.5	—	—	—	\$ 1077
72"W Veneer – Square Edge	AW3VF1872T	62	<input checked="" type="checkbox"/> 5.5	\$ 3328	\$ 3630	—	—

<p>How to specify — Select the Model Number from above.</p> <p>AW3 </p> <p> T .</p>	<p>1st Option: FSC Certified Wood:</p> <p>FSC Select for FSC Certified Wood X No FSC</p>	<p>2nd Option: Laminate or Fluid Form:</p> <p>See inside front cover for finishes.</p>	<p>3rd Option: Edge Color (Laminate only):</p> <p>See inside front cover for finishes.</p>	<p>4th Option: Grommet or Cutout Location (see page 462):</p> <p>AG0 No Grommets AG1 Centered Oval (Add \$13) AG2 Pair Ovals (Add \$25) ATE Pop-up Power Cutout – Centered Side-to-Side, 2" from Back</p> <p>A </p>	<p>5th Option: Grommet Type (if applicable):</p> <p>P Oval Plastic</p>	<p>6th Option: Grommet Color:</p> <p>See page 462 for Oval grommet color offering.</p>
--	---	---	---	---	---	---

Examples: AW3LT1848T.X.LM13EY.AG2PEY

Shippable by small-package carrier.

- Order top separately — see options on page 467. "T" suffix top for T-legs.
- Legs are sold in pairs. Nesting models and T-legs 60"W and wider include beam, order width to match width of top.
- Leg finish options include painted (color specified) or polished. Legs require some assembly.
- Legs below with top from previous page creates seated height 29"H table. Glides provide ½" of adjustment.
- All casters are urethane tread locking casters. Choice of Black or Silver.

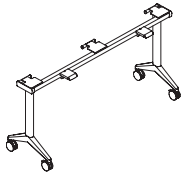
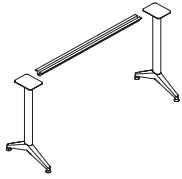

Description	Model + Suffix "B" Painted or "S" Polished	Ship Weight	Cubes	P1 Paint List Price	P2 Paint List Price	P3 Paint List Price	Polished List Price
Fixed 29"H T-Legs for 18"D Tops (60"W and 72"W includes beam)							
48"W or 54"W Pair, Seated Height w/Glides	AW2TSPG □	16	<input checked="" type="checkbox"/> 2.8	\$ 915	\$ 940	\$ 963	\$ 1119
48"W or 54"W Pair, Seated Height w/Casters	AW2TSPC □	16	<input checked="" type="checkbox"/> 2.4	\$ 915	\$ 940	\$ 963	\$ 1119
60"W or 66"W Pair, Seated Height w/Glides	AW2TSPG □ 60 (shown)	23	3.5	\$ 1030	\$ 1055	\$ 1078	\$ 1234
60"W or 66"W Pair, Seated Height w/Casters	AW2TSPC □ 60	23	3.5	\$ 1030	\$ 1055	\$ 1078	\$ 1234
72"W Pair, Seated Height w/Glides	AW2TSPG □ 72	25	3.8	\$ 1059	\$ 1084	\$ 1107	\$ 1263
72"W Pair, Seated Height w/Casters	AW2TSPC □ 72	25	3.8	\$ 1059	\$ 1084	\$ 1107	\$ 1263
Nesting 29"H T-Legs for 18"D Tops (includes beam)							
48"W Kit, Seated Height w/Casters	AW2TS18N48C □	24	4.8	\$ 1455	\$ 1482	\$ 1505	\$ 1675
54"W Kit, Seated Height w/Casters	AW2TS18N54C □	24	5.1	\$ 1474	\$ 1501	\$ 1524	\$ 1699
60"W Kit, Seated Height w/Casters	AW2TS18N60C □ (shown)	32	5.4	\$ 1578	\$ 1605	\$ 1628	\$ 1823
66"W Kit, Seated Height w/Casters	AW2TS18N66C □	33	5.4	\$ 1624	\$ 1651	\$ 1674	\$ 1846
72"W Kit, Seated Height w/Casters	AW2TS18N72C □	35	5.6	\$ 1677	\$ 1704	\$ 1727	\$ 1902

How to specify —
Select the Model Number from above.
Add suffix:
B for Painted
S for Polished

**1st Option:
Paint Color or
PAL for Polished:**
 P1 P2 P3
See page 458
for finishes.

**2nd Option:
Caster Color
(if applicable):**
B Black
S Silver

AW2 | | | | | | | | | | | | | | | | | . | | | | .

Examples: AW2TSPGB.P7D AW2TSPCB60.P7D.B Shippable by small-package carrier.
 AW2TS18N48CS.PAL.S Seating, Social Collaborative, & Tables – 02/2024

- Order legs separately — see options on page 470. “T” suffix top for T-legs and “V” suffix top for V-legs.
- Specify grommet location, type, and color — see page 462.
- Knife edge tops feature shaped edge on all sides. Eased edge tops feature shaped edge on front side.
- Optional electrical components, wire trough, modesty panel, and ganging hardware ordered separately — see pages 483-486.

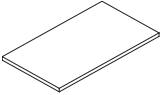

Description	Model + Suffix "T" T-leg / "V" V-leg	Ship Weight	Cubes	List Price			
				L1 or V2	L2 or V3	L3	FF
24"D Table Tops							
36"W Laminate – Flat Edge	AW3LF2436 □	36	3.7	\$ 528	\$ 549	\$ 566	—
36"W Laminate – T-Mold Edge	AW3LT2436 □	36	3.7	\$ 528	\$ 549	\$ 566	—
36"W Laminate – Knife Edge*	AW3LK2436V	36	3.7	\$ 1700	\$ 1758	\$ 1815	—
36"W Fluid Form – Eased Edge	AW3FE2436 □	36	3.7	—	—	—	\$ 829
36"W Veneer – Square Edge	AW3VF2436 □	36	3.7	\$ 2713	\$ 2960	—	—
<hr/>							
42"W Laminate – Flat Edge	AW3LF2442 □ (shown)	41	4.2	\$ 562	\$ 585	\$ 603	—
42"W Laminate – T-Mold Edge	AW3LT2442 □	41	4.2	\$ 562	\$ 585	\$ 603	—
42"W Laminate – Knife Edge	AW3LK2442V	41	4.2	\$ 1709	\$ 1767	\$ 1824	—
42"W Fluid Form – Eased Edge	AW3FE2442 □	41	4.2	—	—	—	\$ 838
42"W Veneer – Square Edge	AW3VF2442 □	41	4.2	\$ 2834	\$ 3092	—	—
<hr/>							
48"W Laminate – Flat Edge	AW3LF2448 □	46	4.8	\$ 596	\$ 620	\$ 640	—
48"W Laminate – T-Mold Edge	AW3LT2448 □	46	4.8	\$ 596	\$ 620	\$ 640	—
48"W Laminate – Knife Edge	AW3LK2448V	46	4.8	\$ 1716	\$ 1774	\$ 1832	—
48"W Fluid Form – Eased Edge	AW3FE2448 □	46	4.8	—	—	—	\$ 846
48"W Veneer – Square Edge	AW3VF2448 □	46	4.8	\$ 2956	\$ 3225	—	—
<hr/>							
54"W Laminate – Flat Edge	AW3LF2454 □	49	5.3	\$ 656	\$ 681	\$ 703	—
54"W Laminate – T-Mold Edge	AW3LT2454 □	49	5.3	\$ 656	\$ 681	\$ 703	—
54"W Laminate – Knife Edge	AW3LK2454V	49	5.3	\$ 1722	\$ 1781	\$ 1838	—
54"W Fluid Form – Eased Edge	AW3FE2454 □	49	5.3	—	—	—	\$ 864
54"W Veneer – Square Edge	AW3VF2454 □	49	5.3	\$ 3082	\$ 3362	—	—

*V-legs are the only option offered for knife edge table tops.

<p>How to specify — Select the Model Number from above.</p> <p>Suffix: T for use with T legs V for use with V legs (Knife “V” only)</p> <p>AW3 </p>	<p>1st Option: FSC Certified Wood:</p> <p>FSC Select for FSC Certified Wood X No FSC</p> <p> .</p>	<p>2nd Option: Laminate or Fluid Form:</p> <p>See inside front cover for finishes.</p> <p> .</p>	<p>3rd Option: Edge Color (Laminate only):</p> <p>See inside front cover for finishes.</p> <p> .</p>	<p>4th Option: Grommet or Cutout Location (see page 462):</p> <p>AG0 No Grommets AG1 Centered Oval (Add \$13) AG2 Pair Ovals (Add \$25) ATE Pop-up Power Cutout – Centered Side-to-Side, 2" from Back</p> <p>A </p>	<p>5th Option: Grommet Type (if applicable):</p> <p>P Oval Plastic</p> <p> </p>	<p>6th Option: Grommet Color:</p> <p>See page 462 for Oval grommet color offering.</p> <p> </p>
---	--	--	--	---	--	--

Examples: AW3LT2436T.X.LM13EY.AG2PEY

AW3VF2454V.FSC.NC777.P

Shippable by small-package carrier.

- Order top separately — see options on page 469. “T” suffix top for T-legs and “V” suffix top for V-legs.
- Legs are sold in pairs. Nesting models include beam, order width to match width of top.
- Leg finish options include painted (color specified) or polished. Legs require some assembly.
- Select legs below with top from previous page to create either a seated height 29"H table or a 42"H standing height table. Glides provide ½" of adjustment.
- All casters are urethane tread locking casters. Choice of Black or Silver.

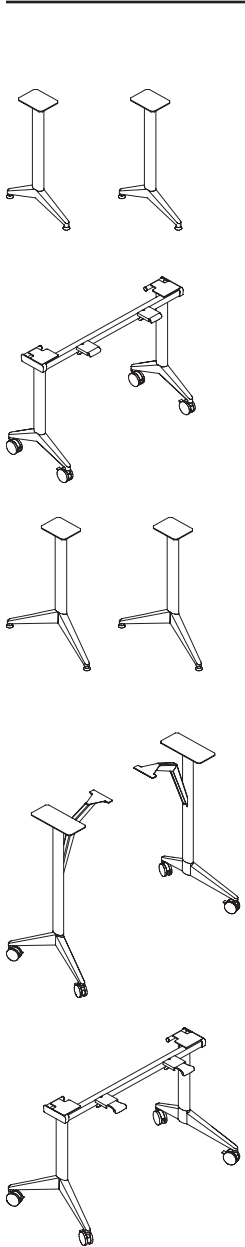

Description	Model + Suffix "B" Painted or "S" Polished	Ship Weight	Cubes	P1 Paint List Price	P2 Paint List Price	P3 Paint List Price	Polished List Price
Fixed 29"H T-Legs for 24"D x 36"W – 54"W Tops							
Pair, Seated Height w/Glides	AW2TSPG <input type="checkbox"/> (shown)	16 <input type="checkbox"/>	2.8	\$ 915	\$ 940	\$ 963	\$ 1119
Pair, Seated Height w/Casters	AW2TSPC <input type="checkbox"/>	16 <input type="checkbox"/>	2.4	\$ 915	\$ 940	\$ 963	\$ 1119
Nesting 29"H T-Legs for 24"D Tops (includes beam)							
36"W Kit, Seated Height w/Casters	AW2TS24N36C <input type="checkbox"/>	22	4.5	\$ 1436	\$ 1463	\$ 1486	\$ 1656
42"W Kit, Seated Height w/Casters	AW2TS24N42C <input type="checkbox"/> (shown)	23	4.5	\$ 1445	\$ 1472	\$ 1495	\$ 1666
48"W Kit, Seated Height w/Casters	AW2TS24N48C <input type="checkbox"/>	24	4.8	\$ 1455	\$ 1482	\$ 1505	\$ 1675
54"W Kit, Seated Height w/Casters	AW2TS24N54C <input type="checkbox"/>	24	5.1	\$ 1474	\$ 1501	\$ 1524	\$ 1699
Fixed 29"H V-Legs for 24"D – 30"D x 36"W – 54"W Tops							
Pair, Seated Height w/Glides	AW2VMPG <input type="checkbox"/> (shown)	18 <input type="checkbox"/>	3.5	\$ 1067	\$ 1092	\$ 1115	\$ 1269
Pair, Seated Height w/Casters	AW2VMPC <input type="checkbox"/>	18 <input type="checkbox"/>	2.4	\$ 1067	\$ 1092	\$ 1115	\$ 1269
Fixed 42"H V-Legs for 24"D x 54"W Tops							
54"W Pair Standing Height w/Glides	AW2VMSHGB	5.8	28	\$ 1417	\$ 1442	\$ 1465	—
54"W Pair Standing Height w/Casters	AW2VMSHCB (shown)	5.8	28	\$ 1417	\$ 1442	\$ 1465	—
Nesting 29"H V-Legs for 24"D Tops (includes beam)							
36"W Kit, Seated Height w/Casters	AW2VM24N36C <input type="checkbox"/>	24	4.5	\$ 1587	\$ 1614	\$ 1637	\$ 1813
42"W Kit, Seated Height w/Casters	AW2VM24N42C <input type="checkbox"/> (shown)	24	4.5	\$ 1598	\$ 1625	\$ 1648	\$ 1823
48"W Kit, Seated Height w/Casters	AW2VM24N48C <input type="checkbox"/>	25	4.5	\$ 1607	\$ 1634	\$ 1657	\$ 1833
54"W Kit, Seated Height w/Casters	AW2VM24N54C <input type="checkbox"/>	26	4.8	\$ 1617	\$ 1644	\$ 1667	\$ 1842

NOTE: T-legs only work with "T" suffix tops and V-legs only work with "V" suffix tops.

<p>How to specify — Select the Model Number from above. Add suffix: B for Painted S for Polished</p> <p>AW2 . .</p>	<p><i>1st Option:</i> Paint Color or PAL for Polished: <input type="checkbox"/> P1 <input type="checkbox"/> P2 <input type="checkbox"/> P3 See page 458 for finishes. Standing height only available as painted.</p>	<p><i>2nd Option:</i> Caster Color (if applicable): B Black S Silver</p>
---	--	---

Examples: AW2TSPGB.P7D AW2TSPCB.P7D.B AW2TS24N36CS.PAL.S Shippable by small-package carrier.

- Order legs separately — see options on page 472. “T” suffix top for T-legs and “V” suffix top for V-legs.
- Specify grommet location, type, and color — see page 462.
- Knife edge tops feature shaped edge on all sides. Eased edge tops feature shaped edge on front side.
- Optional electrical components, wire trough, modesty panel, and ganging hardware ordered separately — see pages 483-486.

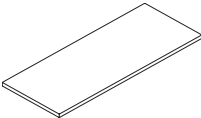

Description	Model + Suffix "T" T-leg / "V" V-leg	Ship Weight	Cubes	List Price			
				L1 or V2	L2 or V3	L3	FF
24"D Table Tops							
60"W Laminate – Flat Edge	AW3LF2460 □	53 [S]	5.9	\$ 717	\$ 745	\$ 767	—
60"W Laminate – T-Mold Edge	AW3LT2460 □	53 [S]	5.9	\$ 717	\$ 745	\$ 767	—
60"W Laminate – Knife Edge*	AW3LK2460V	53 [S]	5.9	\$ 1733	\$ 1792	\$ 1851	—
60"W Fluid Form – Eased Edge	AW3FE2460 □	53 [S]	5.9	—	—	—	\$ 878
60"W Veneer – Square Edge	AW3VF2460 □	53 [S]	5.9	\$ 3208	\$ 3500	—	—
<hr/>							
66"W Laminate – Flat Edge	AW3LF2466 □	64 [S]	6.4	\$ 767	\$ 796	\$ 821	—
66"W Laminate – T-Mold Edge	AW3LT2466 □	64 [S]	6.4	\$ 767	\$ 796	\$ 821	—
66"W Laminate – Knife Edge*	AW3LK2466V	64 [S]	6.4	\$ 1808	\$ 1869	\$ 1931	—
66"W Fluid Form – Eased Edge	AW3FE2466 □	64 [S]	6.4	—	—	—	\$ 1077
66"W Veneer – Square Edge	AW3VF2466 □	64 [S]	6.4	\$ 3328	\$ 3630	—	—
<hr/>							
72"W Laminate – Flat Edge	AW3LF2472 □	75 [S]	6.9	\$ 811	\$ 842	\$ 867	—
72"W Laminate – T-Mold Edge	AW3LT2472 □	75 [S]	6.9	\$ 811	\$ 842	\$ 867	—
72"W Laminate – Knife Edge*	AW3LK2472V	75 [S]	6.9	\$ 1891	\$ 1955	\$ 2019	—
72"W Fluid Form – Eased Edge	AW3FE2472 □	75 [S]	6.9	—	—	—	\$ 1273
72"W Veneer – Square Edge	AW3VF2472 □	75 [S]	6.9	\$ 3454	\$ 3768	—	—
<hr/>							
84"W Laminate – Flat Edge	AW3LF2484 □	91 [S]	8.0	\$ 936	\$ 970	\$ 1001	—
84"W Laminate – T-Mold Edge	AW3LT2484 □	91 [S]	8.0	\$ 936	\$ 970	\$ 1001	—
84"W Laminate – Knife Edge*	AW3LK2484V	91 [S]	8.0	\$ 2082	\$ 2152	\$ 2222	—
84"W Fluid Form – Eased Edge	AW3FE2484 □	91 [S]	8.0	—	—	—	\$ 1773
84"W Veneer – Square Edge	AW3VF2484 □	91 [S]	8.0	\$ 3770	\$ 4113	—	—
<hr/>							
96"W Laminate – Flat Edge	AW3LF2496 □	100	9.1	\$ 1128	\$ 1169	\$ 1205	—
96"W Laminate – T-Mold Edge	AW3LT2496 □	100	9.1	\$ 1128	\$ 1169	\$ 1205	—
96"W Laminate – Knife Edge*	AW3LK2496V	100	9.1	\$ 2392	\$ 2473	\$ 2554	—
96"W Fluid Form – Eased Edge	AW3FE2496 □	100	9.1	—	—	—	\$ 2557
96"W Veneer – Square Edge	AW3VF2496 □	100	9.1	\$ 4271	\$ 4659	—	—



*V-legs are the only option offered for knife edge table tops.

<p>How to specify — Select the Model Number from above.</p> <p>Suffix: T for use with T legs V for use with V legs (Knife “V” only)</p> <p>AW3 </p>	<p>1st Option: FSC Certified Wood:</p> <p>FSC Select for FSC Certified Wood X No FSC</p>	<p>2nd Option: Laminate or Fluid Form:</p> <p>See inside front cover for finishes.</p>	<p>3rd Option: Edge Color (Laminate only):</p> <p>See inside front cover for finishes.</p>	<p>4th Option: Grommet or Cutout Location (see page 462):</p> <p>AG0 No Grommets AG1 Centered Oval (Add \$13) AG2 Pair Ovals (Add \$25) ATE Pop-up Power Cutout – Centered Side-to-Side, 2" from Back</p> <p>A </p>	<p>5th Option: Grommet Type (if applicable):</p> <p>P Oval Plastic</p>	<p>6th Option: Grommet Color:</p> <p>See page 462 for Oval grommet color offering.</p>
---	---	---	---	---	---	---

Examples: AW3LT2460T.X.LM13EY.AG2PEY

[S] Shippable by small-package carrier.

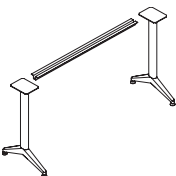
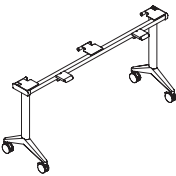
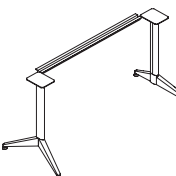
- Order Top separately — see options on page 471. “T” suffix top for T-legs and “V” suffix top for V-legs.
- Leg finish options include painted (color specified) or polished. Legs require some assembly. Standing height models come with external stiffener.
- Legs are sold in pairs. Nesting models include beam, order width to match width of top.
- Select legs below with top from previous page to create either a seated height 29"H table or a 42"H standing height table. Glides provide 1/2" of adjustment.
- All casters are urethane tread locking casters. Choice of Black or Silver.

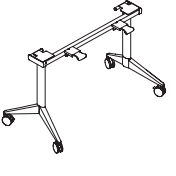
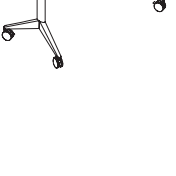
Description	Model + Suffix "B" Painted or "S" Polished	Ship Weight	Cubes	P1 Paint List Price	P2 Paint List Price	P3 Paint List Price	Polished List Price
Fixed 29" H T-Legs for 24" D Tops (includes beam)							
60" - 66" W Kit, Seated Height w/Glides 	AW2TSPG □ 60 (shown)	23	3.5	\$ 1030	\$ 1055	\$ 1078	\$ 1234
60" - 66" W Kit, Seated Height w/Casters	AW2TSPC □ 60	23	3.5	\$ 1030	\$ 1055	\$ 1078	\$ 1234
72" W Kit, Seated Height w/Glides	AW2TSPG □ 72	25	3.8	\$ 1059	\$ 1084	\$ 1107	\$ 1263
72" W Kit, Seated Height w/Casters	AW2TSPC □ 72	25	3.8	\$ 1059	\$ 1084	\$ 1107	\$ 1263
84" W Kit, Seated Height w/Glides	AW2TSPG □ 84	27	4.2	\$ 1088	\$ 1113	\$ 1136	\$ 1292
84" W Kit, Seated Height w/Casters	AW2TSPC □ 84	27	4.2	\$ 1088	\$ 1113	\$ 1136	\$ 1292
96" W Kit, Seated Height w/Glides	AW2TSPG □ 96	28	4.2	\$ 1317	\$ 1342	\$ 1365	\$ 1521
96" W Kit, Seated Height w/Casters	AW2TSPC □ 96	28	4.2	\$ 1317	\$ 1342	\$ 1365	\$ 1521
Nesting 29" H T-Legs for 24" D Tops (includes beam)							
60" W Kit, Seated Height w/Casters 	AW2TS24N60C □ (shown)	32	5.4	\$ 1578	\$ 1605	\$ 1628	\$ 1823
66" W Kit, Seated Height w/Casters	AW2TS24N66C □	33	5.4	\$ 1624	\$ 1651	\$ 1674	\$ 1846
72" W Kit, Seated Height w/Casters	AW2TS24N72C □	35	5.6	\$ 1677	\$ 1704	\$ 1727	\$ 1902
84" W Kit, Seated Height w/Casters	AW2TS24N84C □	40	6.1	\$ 1759	\$ 1786	\$ 1809	\$ 1979
96" W Kit, Seated Height w/Casters	AW2TS24N96C □	44	6.5	\$ 1836	\$ 1863	\$ 1886	\$ 2054
Fixed 29" H V-Legs for 24" D Tops (includes beam)							
60" - 66" W Kit, Seated Height w/Glides 	AW2VMPG □ 60 (shown)	25	4.3	\$ 1182	\$ 1207	\$ 1230	\$ 1384
60" - 66" W Kit, Seated Height w/Casters	AW2VMPC □ 60	25	4.3	\$ 1182	\$ 1207	\$ 1230	\$ 1384
72" W Kit, Seated Height w/Glides	AW2VMPG □ 72	27	4.5	\$ 1211	\$ 1236	\$ 1259	\$ 1413
72" W Kit, Seated Height w/Casters	AW2VMPC □ 72	27	4.5	\$ 1211	\$ 1236	\$ 1259	\$ 1413
84" W Kit, Seated Height w/Glides	AW2VMPG □ 84	29	5.0	\$ 1240	\$ 1265	\$ 1288	\$ 1442
84" W Kit, Seated Height w/Casters	AW2VMPC □ 84	29	5.0	\$ 1240	\$ 1265	\$ 1288	\$ 1442
96" W Kit, Seated Height w/Glides	AW2VMPG □ 96	30	5.0	\$ 1469	\$ 1494	\$ 1517	\$ 1671
96" W Kit, Seated Height w/Casters	AW2VMPC □ 96	30	5.0	\$ 1469	\$ 1494	\$ 1517	\$ 1671
Fixed 42" H V-Legs for 24" D Tops							
60"-66" W Kit Standing Height w/Glides	AW2VMSHGB60	6.6	35	\$ 1532	\$ 1557	\$ 1580	—
60"-66" W Kit Standing Height w/Casters 	AW2VMSHCB60 (shown)	6.6	35	\$ 1532	\$ 1557	\$ 1580	—
72" W Kit Standing Height w/Glides	AW2VMSHGB72	6.8	37	\$ 1561	\$ 1586	\$ 1609	—
72" W Kit Standing Height w/Casters	AW2VMSHCB72	6.8	37	\$ 1561	\$ 1586	\$ 1609	—
84" W Kit Standing Height w/Glides	AW2VMSHGB84	7.3	39	\$ 1590	\$ 1615	\$ 1638	—
84" W Kit Standing Height w/Casters 	AW2VMSHCB84	7.3	39	\$ 1590	\$ 1615	\$ 1638	—
Nesting 29" H V-Legs for 24" D Tops (includes beam)							
60" W Kit, Seated Height w/Casters 	AW2VM24N60C □ (shown)	33	5.1	\$ 1751	\$ 1778	\$ 1801	\$ 1981
66" W Kit, Seated Height w/Casters	AW2VM24N66C □	34	5.4	\$ 1740	\$ 1767	\$ 1790	\$ 1990
72" W Kit, Seated Height w/Casters	AW2VM24N72C □	37	5.4	\$ 1815	\$ 1842	\$ 1865	\$ 2042
84" W Kit, Seated Height w/Casters	AW2VM24N84C □	41	6.1	\$ 1897	\$ 1924	\$ 1947	\$ 2120
96" W Kit, Seated Height w/Casters	AW2VM24N96C □	45	6.5	\$ 1973	\$ 2000	\$ 2023	\$ 2199

NOTE: T-legs only work with "T" suffix tops and V-legs only work with "V" suffix tops.

<p>How to specify — Select the Model Number from above. Add suffix: B for Painted S for Polished</p> <p>AW2 . .</p>	<p><i>1st Option:</i> Paint Color or PAL for Polished: P1 P2 P3 See page 458 for finishes. Standing height only available as painted.</p>	<p><i>2nd Option:</i> Caster Color (if applicable): B Black S Silver (<i>coming soon</i>)</p>
---	--	--

Examples: **AW2TSPGB60.P7D AW2TSPCB60.P7D.B AW2TS24N60CS.PAL.S** [5] Shippable by small-package carrier.

- Order legs separately — see options on page 474. “T” suffix top for T-legs and “V” suffix top for V-legs.
- Specify grommet location, type, and color — see page 462.
- Knife edge tops feature shaped edge on all sides. Eased edge tops feature shaped edge on front side.
- Optional electrical components, wire trough, modesty panel, and ganging hardware ordered separately — see pages 483-486.

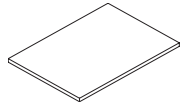

Description	Model + Suffix "T" T-leg / "V" V-leg	Ship Weight	Cubes	List Price				
				L1 or V2	L2 or V3	L3	FF	
30"D Table Tops								
36"W Laminate – Flat Edge	AW3LF3036 □	43 [S]	4.4	\$ 562	\$ 585	\$ 603	—	
36"W Laminate – T-Mold Edge	AW3LT3036 □	43 [S]	4.4	\$ 562	\$ 585	\$ 603	—	
36"W Laminate – Knife Edge*	AW3LK3036V	43 [S]	4.4	\$ 1709	\$ 1767	\$ 1824	—	
36"W Fluid Form – Eased Edge	AW3FE3036 □	43 [S]	4.4	—	—	—	\$ 838	
36"W Veneer – Square Edge	AW3VF3036 □	43 [S]	4.4	\$ 2834	\$ 3092	—	—	
<hr/>								
42"W Laminate – Flat Edge	AW3LF3042 □	51 [S]	5.1	\$ 596	\$ 620	\$ 640	—	
42"W Laminate – T-Mold Edge	AW3LT3042 □	51 [S]	5.1	\$ 596	\$ 620	\$ 640	—	
42"W Laminate – Knife Edge	AW3LK3042V	51 [S]	5.1	\$ 1716	\$ 1774	\$ 1832	—	
42"W Fluid Form – Eased Edge	AW3FE3042 □	51 [S]	5.1	—	—	—	\$ 846	
42"W Veneer – Square Edge	AW3VF3042 □	51 [S]	5.1	\$ 2956	\$ 3225	—	—	
<hr/>								
48"W Laminate – Flat Edge	AW3LF3048 □	58 [S]	5.8	\$ 646	\$ 671	\$ 692	—	
48"W Laminate – T-Mold Edge	AW3LT3048 □	58 [S]	5.8	\$ 646	\$ 671	\$ 692	—	
48"W Laminate – Knife Edge	AW3LK3048V	58 [S]	5.8	\$ 1697	\$ 1755	\$ 1812	—	
48"W Fluid Form – Eased Edge	AW3FE3048 □	58 [S]	5.8	—	—	—	\$ 876	
48"W Veneer – Square Edge	AW3VF3048 □	58 [S]	5.8	\$ 3140	\$ 3425	—	—	
<hr/>								
54"W Laminate – Flat Edge	AW3LF3054 □	65 [S]	6.4	\$ 723	\$ 751	\$ 773	—	
54"W Laminate – T-Mold Edge	AW3LT3054 □	65 [S]	6.4	\$ 723	\$ 751	\$ 773	—	
54"W Laminate – Knife Edge	AW3LK3054V	65 [S]	6.4	\$ 1794	\$ 1854	\$ 1916	—	
54"W Fluid Form – Eased Edge	AW3FE3054 □	65 [S]	6.4	—	—	—	\$ 951	
54"W Veneer – Square Edge	AW3VF3054 □	65 [S]	6.4	\$ 3254	\$ 3550	—	—	

*V-legs are the only option offered for knife edge table tops.

<p>How to specify — Select the Model Number from above.</p> <p>Suffix: T for use with T legs V for use with V legs (Knife “V” only)</p>	<p>1st Option: FSC Certified Wood:</p> <p>FSC Select for FSC Certified Wood X No FSC</p>	<p>2nd Option: Laminate or Fluid Form:</p> <p>See inside front cover for finishes.</p>	<p>3rd Option: Edge Color (Laminate only):</p> <p>See inside front cover for finishes.</p>	<p>4th Option: Grommet or Cutout Location (see page 462):</p> <p>AG0 No Grommets AG1 Centered Oval (Add \$13) AG2 Pair Ovals (Add \$25) ATE Pop-up Power Cutout – Centered Side-to-Side, 2" from Back ATC Cutout – Centered Side-to-Side, Front-to-Back (Not for Nesting)</p>	<p>5th Option: Grommet Type (if applicable):</p> <p>P Oval Plastic</p>	<p>6th Option: Grommet Color:</p> <p>See page 462 for Oval grommet color offering.</p>
AW3				A		

Examples: AW3LT3036T.X.LM13EY.AG2PEY

AW3VF3054V.FSC.SC777.P

[S] Shippable by small-package carrier.

- Order Top separately - see options on page 473. "T" suffix top for T-legs and "V" suffix top for V-legs.
- Legs are sold in pairs. Nesting models include beam, order width to match width of top.
- Leg finish options include painted (color specified) or polished. Legs require some assembly.
- Select legs below with top from previous page to create either a seated height 29"H table or a 42"H standing height table. Glides provide ½" of adjustment.
- All casters are urethane tread locking casters. Choice of Black or Silver.

Description	Model + Suffix "B" Painted or "S" Polished	Ship Weight	Cubes	P1 Paint List Price	P2 Paint List Price	P3 Paint List Price	Polished List Price
Fixed 29"H T-Legs for 30"D x 36"W – 54"W Tops							
Pair, Seated Height w/Glides	AW2TLPG □	19	5	\$ 965	\$ 990	\$ 1013	\$ 1169
Pair, Seated Height w/Casters	AW2TLPC □	19	5	\$ 965	\$ 990	\$ 1013	\$ 1169
Nesting 29"H T-Legs for 30"D Tops (includes beam)							
36"W Kit, Seated Height w/Casters	AW2TL30N36C □	24	6.3	\$ 1488	\$ 1515	\$ 1538	\$ 1709
42"W Kit, Seated Height w/Casters	AW2TL30N42C □	25	6.3	\$ 1497	\$ 1524	\$ 1547	\$ 1719
48"W Kit, Seated Height w/Casters	AW2TL30N48C □	26	6.5	\$ 1507	\$ 1534	\$ 1557	\$ 1728
54"W Kit, Seated Height w/Casters	AW2TL30N54C □	26	6.8	\$ 1526	\$ 1553	\$ 1576	\$ 1752
Fixed 29"H V-Legs for 24"D – 30"D x 36"W – 54"W Tops							
Pair, Seated Height w/Glides	AW2VMPG □	18	5	\$ 1067	\$ 1092	\$ 1115	\$ 1269
Pair, Seated Height w/Casters	AW2VMPC □	18	5	\$ 1067	\$ 1092	\$ 1115	\$ 1269
Fixed 42"H T-Legs for 30"D x 54"W Tops							
54"W Pair Standing Height w/Glides	AW2TLSHGB	5.8	28	\$ 1217	\$ 1242	\$ 1265	—
54"W Pair Standing Height w/Casters	AW2TLSHCB	5.8	28	\$ 1217	\$ 1242	\$ 1265	—
	(shown)						
Nesting 29"H V-Legs for 30"D Tops (includes beam)							
36"W Kit, Seated Height w/Casters	AW2VM30N36C □	24	6.3	\$ 1587	\$ 1614	\$ 1637	\$ 1813
42"W Kit, Seated Height w/Casters	AW2VM30N42C □	24	6.3	\$ 1598	\$ 1625	\$ 1648	\$ 1823
48"W Kit, Seated Height w/Casters	AW2VM30N48C □	25	6.3	\$ 1607	\$ 1634	\$ 1657	\$ 1833
54"W Kit, Seated Height w/Casters	AW2VM30N54C □	26	6.5	\$ 1617	\$ 1644	\$ 1667	\$ 1842

NOTE: T-legs only work with "T" suffix tops and V-legs only work with "V" suffix tops.

<p>How to specify —</p> <p>Select the Model Number from above.</p> <p>Add suffix: B for Painted S for Polished</p>	<p>1st Option:</p> <p>Paint Color or PAL for Polished:</p> <p>P1 P2 P3</p> <p>See page 458 for finishes.</p> <p>Standing height only available as painted.</p>	<p>2nd Option:</p> <p>Caster Color (if applicable):</p> <p>B Black S Silver</p>
---	--	---

AW2 | | | | | | | | | | . | | | | | | . | |

Examples: AW2TLPG.B P7D AW2TLPC.B P7D.B AW2TL30N36C.S.PAL.S S Shippable by small-package carrier.

- Order legs separately — see options on page 476. “T” suffix top for T-legs and “V” suffix top for V-legs.
- Specify grommet location, type, and color — see page 462.
- Knife edge tops feature shaped edge on all sides. Eased edge tops feature shaped edge on front side.
- Optional electrical components, wire trough, modesty panel, and ganging hardware ordered separately — see pages 483-486.

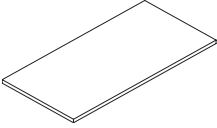

Description	Model + Suffix "T" T-leg / "V" V-leg	Ship Weight	Cubes	List Price				
				L1 or V2	L2 or V3	L3	FF	
30"D Table Tops								
60"W Laminate – Flat Edge	AW3LF3060 □	78	5	7.1	\$ 799	\$ 829	\$ 854	—
60"W Laminate – T-Mold Edge	AW3LT3060 □	78	5	7.1	\$ 799	\$ 829	\$ 854	—
60"W Laminate – Knife Edge*	AW3LK3060V	78	5	7.1	\$ 1888	\$ 1952	\$ 2016	—
60"W Fluid Form – Eased Edge	AW3FE3060 □	78	5	7.1	—	—	—	\$ 1029
60"W Veneer – Square Edge	AW3VF3060 □	78	5	7.1	\$ 3366	\$ 3672	—	—
66"W Table Tops								
66"W Laminate – Flat Edge	AW3LF3066 □	86	5	7.7	\$ 858	\$ 890	\$ 918	—
66"W Laminate – T-Mold Edge	AW3LT3066 □	86	5	7.7	\$ 858	\$ 890	\$ 918	—
66"W Laminate – Knife Edge	AW3LK3066V	86	5	7.7	\$ 1976	\$ 2042	\$ 2109	—
66"W Fluid Form – Eased Edge	AW3FE3066 □	86	5	7.7	—	—	—	\$ 1154
66"W Veneer – Square Edge	AW3VF3066 □	86	5	7.7	\$ 3482	\$ 3798	—	—
72"W Table Tops								
72"W Laminate – Flat Edge	AW3LF3072 □	93	5	8.4	\$ 916	\$ 949	\$ 980	—
72"W Laminate – T-Mold Edge	AW3LT3072 □	93	5	8.4	\$ 916	\$ 949	\$ 980	—
72"W Laminate – Knife Edge	AW3LK3072V	93	5	8.4	\$ 2066	\$ 2134	\$ 2203	—
72"W Fluid Form – Eased Edge	AW3FE3072 □	93	5	8.4	—	—	—	\$ 1281
72"W Veneer – Square Edge	AW3VF3072 □	93	5	8.4	\$ 3590	\$ 3916	—	—
84"W Table Tops								
84"W Laminate – Flat Edge	AW3LF3084 □	109	9.7	9.7	\$ 1127	\$ 1168	\$ 1204	—
84"W Laminate – T-Mold Edge	AW3LT3084 □	109	9.7	9.7	\$ 1127	\$ 1168	\$ 1204	—
84"W Laminate – Knife Edge	AW3LK3084V	109	9.7	9.7	\$ 2452	\$ 2536	\$ 2620	—
84"W Fluid Form – Eased Edge	AW3FE3084 □	109	9.7	9.7	—	—	—	\$ 1778
84"W Veneer – Square Edge	AW3VF3084 □	109	9.7	9.7	\$ 3991	\$ 4354	—	—
96"W Table Tops								
96"W Laminate – Flat Edge	AW3LF3096 □	123	11.0	11.0	\$ 1532	\$ 1586	\$ 1637	—
96"W Laminate – T-Mold Edge	AW3LT3096 □	123	11.0	11.0	\$ 1532	\$ 1586	\$ 1637	—
96"W Laminate – Knife Edge	AW3LK3096V	123	11.0	11.0	\$ 3115	\$ 3222	\$ 3329	—
96"W Fluid Form – Eased Edge	AW3FE3096 □	123	11.0	11.0	—	—	—	\$ 2636
96"W Veneer – Square Edge	AW3VF3096 □	123	11.0	11.0	\$ 4759	\$ 5192	—	—

*V-legs are the only option offered for knife edge table tops.

<p>How to specify — Select the Model Number from above.</p> <p>Suffix: T for use with T legs V for use with V legs (Knife “V” only)</p>	<p>1st Option: FSC Certified Wood:</p> <p>FSC Select for FSC Certified Wood X No FSC</p>	<p>2nd Option: Laminate or Fluid Form:</p> <p>See inside front cover for finishes.</p>	<p>3rd Option: Edge Color (Laminate only):</p> <p>See inside front cover for finishes.</p>	<p>4th Option: Grommet or Cutout Location (see page 462):</p> <p>AG0 No Grommets AG1 Centered Oval (Add \$13) AG2 Pair Ovals (Add \$25) ATE Pop-up Power Cutout – Centered Side-to-Side, 2" from Back ATC Cutout – Centered Side-to-Side, Front-to-Back (Not for Nesting)</p>	<p>5th Option: Grommet Type (if applicable):</p> <p>P Oval Plastic</p>	<p>6th Option: Grommet Color:</p> <p>See page 462 for Oval grommet color offering.</p>
--	---	---	---	--	---	---

AW3 | | | | | .

Examples: AW3LT3060T.X.LM13EY.AG2PEY

Shippable by small-package carrier.

- Order “T” legs separately — see options on page 478.
- Specify grommet location, type, and color — see page 462.
- Eased edge tops feature shaped edge on front side.
- Optional electrical components, wire trough, modesty panel, and ganging hardware ordered separately — see pages 483-486.

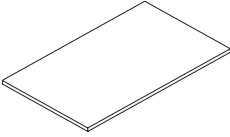

Description	Model	Ship Weight	Cubes	List Price			
				L1 or V2	L2 or V3	L3	FF
36"D Table Tops							
48"W Laminate – Flat Edge	AW3LF3648T	58	6.8	\$ 851	\$ 883	\$ 910	—
48"W Laminate – T-Mold Edge	AW3LT3648T	58	6.8	\$ 851	\$ 883	\$ 910	—
48"W Fluid Form – Eased Edge	AW3FE3648T	58	6.8	—	—	—	\$ 1067
48"W Veneer – Square Edge	AW3VF3648T	58	6.8	\$ 3761	\$ 4103	—	—
54"W Laminate – Flat Edge	AW3LF3654T	65	7.5	\$ 914	\$ 947	\$ 978	—
54"W Laminate – T-Mold Edge	AW3LT3654T	65	7.5	\$ 914	\$ 947	\$ 978	—
54"W Fluid Form – Eased Edge	AW3FE3654T	65	7.5	—	—	—	\$ 1080
54"W Veneer – Square Edge	AW3VF3654T	65	7.5	\$ 3882	\$ 4235	—	—
60"W Laminate – Flat Edge	AW3LF3660T (shown)	73	8.3	\$ 978	\$ 1014	\$ 1045	—
60"W Laminate – T-Mold Edge	AW3LT3660T	73	8.3	\$ 978	\$ 1014	\$ 1045	—
60"W Fluid Form – Eased Edge	AW3FE3660T	73	8.3	—	—	—	\$ 1093
60"W Veneer – Square Edge	AW3VF3660T	73	8.3	\$ 4006	\$ 4370	—	—
66"W Laminate – Flat Edge	AW3LF3666T	86	9.1	\$ 1033	\$ 1070	\$ 1104	—
66"W Laminate – T-Mold Edge	AW3LT3666T	86	9.1	\$ 1033	\$ 1070	\$ 1104	—
66"W Fluid Form – Eased Edge	AW3FE3666T	86	9.1	—	—	—	\$ 1356
66"W Veneer – Square Edge	AW3VF3666T	86	9.1	\$ 4128	\$ 4503	—	—
72"W Laminate – Flat Edge	AW3LF3672T	93	9.9	\$ 1089	\$ 1129	\$ 1163	—
72"W Laminate – T-Mold Edge	AW3LT3672T	93	9.9	\$ 1089	\$ 1129	\$ 1163	—
72"W Fluid Form – Eased Edge	AW3FE3672T	93	9.9	—	—	—	\$ 1616
72"W Veneer – Square Edge	AW3VF3672T	93	9.9	\$ 4240	\$ 4625	—	—

*V-legs are the only option offered for knife edge table tops.

<p>How to specify — Select the Model Number from above.</p> <p>AW3 </p>	<p>1st Option: FSC Certified Wood:</p> <p>FSC Select for FSC Certified Wood X No FSC</p>	<p>2nd Option: Laminate or Fluid Form:</p> <p>See inside front cover for finishes.</p>	<p>3rd Option: Edge Color (Laminate only):</p> <p>See inside front cover for finishes.</p>	<p>4th Option: Grommet or Cutout Location (see page 462):</p> <p>AG0 No Grommets AG1 Centered Oval (Add \$13) AG2 Pair Ovals (Add \$25) ATE Pop-up Power Cutout – Centered Side-to-Side, 2" from Back ATC Cutout – Centered Side-to-Side, Front-to-Back (Not for Nesting)</p>	<p>5th Option: Grommet Type (if applicable):</p> <p>P Oval Plastic</p>	<p>6th Option: Grommet Color:</p> <p>See page 462 for Oval grommet color offering.</p>
---	---	---	---	--	---	---

Examples: AW3LT2436T.X.LM13EY.AG2PEY

Shippable by small-package carrier.

- Order top separately — see options on page 477.
- Legs are sold in pairs. Fixed legs 60"W and wider and all nesting models include beam, order width to match width of top.
- Leg finish options include painted (color specified) or polished. Legs require some assembly.
- Legs below with top from previous page creates seated height 29"H table. Glides provide ½" of adjustment.
- All casters are urethane tread locking casters. Choice of Black or Silver.

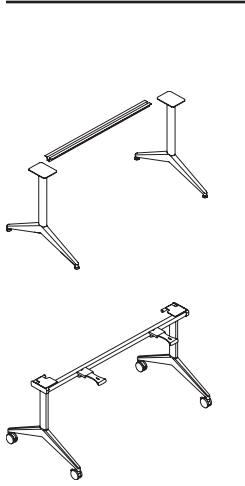

Description	Model + Suffix "B" Painted or "S" Polished	Ship Weight	Cubes	P1 Paint List Price	P2 Paint List Price	P3 Paint List Price	Polished List Price
Fixed T-Legs for 36"D (60" and wider include beam)							
48" – 54" W Pair, Fixed Height w/Glides	AW2TLPG □	19	[S] 4.9	\$ 965	\$ 990	\$ 1013	\$ 1169
48" – 54" Pair, Fixed Height w/Casters	AW2TLPC □	19	[S] 4.1	\$ 965	\$ 990	\$ 1013	\$ 1169
60" – 66" W Kit, Fixed Height w/Glides	AW2TLPG □ 60	26	5.7	\$ 1080	\$ 1105	\$ 1128	\$ 1284
60" – 66" W Kit, Fixed Height w/Casters	AW2TLPC □ 60	23	3.5	\$ 1080	\$ 1105	\$ 1128	\$ 1284
72" W Kit, Fixed Height w/Glides	AW2TLPG □ 72	28	5.9	\$ 1109	\$ 1134	\$ 1157	\$ 1313
72" W Kit, Fixed Height w/Casters	AW2TLPC □ 72	28	5.9	\$ 1109	\$ 1134	\$ 1157	\$ 1313
Nesting T-Legs for 36"D Tops (includes beam)							
48" W Kit, Fixed Height w/Casters	AW2TL36N48C □	26	6.5	\$ 1507	\$ 1534	\$ 1557	\$ 1728
54" W Kit, Fixed Height w/Casters	AW2TL36N54C □	26	6.8	\$ 1526	\$ 1553	\$ 1576	\$ 1752
60" W Kit, Fixed Height w/Casters	AW2TL36N60C □	27	7.1	\$ 1630	\$ 1657	\$ 1680	\$ 1876
66" W Kit, Fixed Height w/Casters	AW2TL36N66C □	35	7.1	\$ 1676	\$ 1703	\$ 1726	\$ 1899
72" W Kit, Fixed Height w/Casters	AW2TL36N72C □	37	7.3	\$ 1729	\$ 1756	\$ 1779	\$ 1955

NOTE: T-legs only work with "T" suffix tops and V-legs only work with "V" suffix tops.

<p>How to specify — Select the Model Number from above. Add suffix: B for Painted S for Polished</p>	<p>1st Option: Paint Color or PAL for Polished: P1 P2 P3 See page 458 for finishes.</p>	<p>2nd Option: Caster Color (if applicable): B Black S Silver</p>
<p>AW2 . . </p>		

Examples: AW2TLPG.B.P7D AW2TLPC.B.P7D.B AW2TL36N48CS.PAL.S [S] Shippable by small-package carrier.

- Order Top separately — see options on page 479. “T” suffix top for T-legs and “V” suffix top for V-legs.
- Leg finish options include painted (color specified) or polished. Legs require some assembly.
- All casters are urethane tread locking casters. Choice of Black or Silver.
- Legs are sold in pairs. Nesting models include beam.
- Legs below with top from previous page creates seated height 29"H table. Glides provide 1/2" of adjustment.

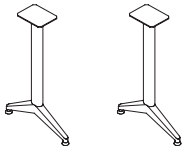
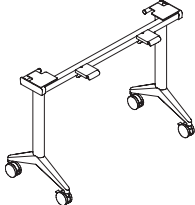
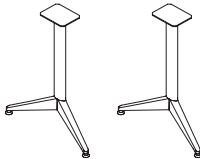
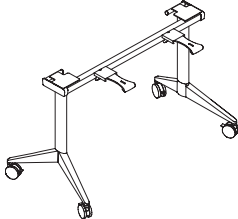
Description		Model + Suffix "B" Painted or "S" Polished	Ship Weight	Cubes	P1 Paint List Price	P2 Paint List Price	P3 Paint List Price	Polished List Price
Fixed T-Legs 	For 24"D x 60"W Trapezoid or 24"D x 48"W Half-Round Tops							
	Pair, Fixed Height w/Glides	AW2TSPG □	16	2.8	\$ 915	\$ 940	\$ 963	\$ 1119
	Pair, Fixed Height w/Casters	AW2TSPC □	16	2.4	\$ 915	\$ 940	\$ 963	\$ 1119
	For 36"D x 72"W Half-Round Tops							
	Pair, Fixed Height w/Glides	AW2TLPG □	19	4.9	\$ 965	\$ 990	\$ 1013	\$ 1169
	Pair, Fixed Height w/Casters	AW2TLPC □	19	4.1	\$ 965	\$ 990	\$ 1013	\$ 1169
Nesting T-Legs 	For 24"D x 48"W Half-Round Tops							
	36"W Kit, Fixed Height w/Casters	AW2TS24N36C □	22	4.5	\$ 1436	\$ 1463	\$ 1486	\$ 1656
	For 24"D x 60"W Trapezoid Tops							
	42"W Kit, Fixed Height w/Casters	AW2TS24N42C □	23	4.5	\$ 1445	\$ 1472	\$ 1495	\$ 1666
	For 36"D x 72"W Half-Round Tops							
	54"W Kit, Fixed Height w/Casters	AW2TL30N54C □	26	6.8	\$ 1526	\$ 1553	\$ 1576	\$ 1752
Fixed V-Legs 	For 30"D x 72"W Trapezoid or 24"D x 48"W and 30"D x 60"W Half-Round Tops							
	Pair, Fixed Height w/Glides	AW2VMPG □	18	3.5	\$ 1067	\$ 1092	\$ 1115	\$ 1269
	Pair, Fixed Height w/Casters	AW2VMPC □	18	2.4	\$ 1067	\$ 1092	\$ 1115	\$ 1269
Nesting V-Legs 	For 24"D x 48"W Trapezoid or 30"D x 60"W Half-Round Tops							
	42"W Kit, Fixed Height w/Casters	AW2VM24N42C □	24	4.5	\$ 1598	\$ 1625	\$ 1648	\$ 1823
	For 30"D x 72"W Trapezoid Tops							
	48"W Kit, Fixed Height w/Casters	AW2VM30N48C □	25	6.3	\$ 1607	\$ 1634	\$ 1657	\$ 1833

<p>How to specify — Select the Model Number from above. Add suffix: B for Painted S for Polished</p>	<p>1st Option: Paint Color or PAL for Polished:</p> <p>P1 P2 P3</p> <p>See page 458 for finishes.</p>	<p>2nd Option: Caster Color (if applicable):</p> <p>B Black S Silver</p>
---	---	---

AW2 | | | | | | | | | | | | | | | | | | | | | | . | | | | | | | | . | | |

Examples: AW2TSPGB.P7B AW2VM24N42CS.PAL.S

Shippable by small-package carrier.

- Order Top separately — see options on page 481. “T” suffix top for T-legs and “V” suffix top for V-legs.
- Leg finish options include painted (color specified) or polished. Legs require some assembly.
- All casters are urethane tread locking casters. Choice of Black or Silver.
- Legs are sold in pairs. Nesting models include beam.
- Legs below with top from previous page creates seated height 29"H table. Glides provide ½" of adjustment.

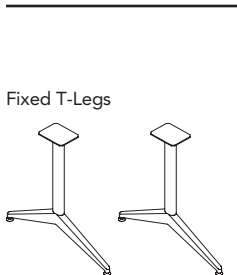

Fixed T-Legs

Description	Model + Suffix "B" Painted or "S" Polished	Ship Weight	Cubes	P1 Paint List Price	P2 Paint List Price	P3 Paint List Price	Polished List Price
For 30"D x 66"W Polygon or 30"D x 85"W Crescent Tops							
Pair, Fixed Height w/Glides	AW2TLPG □	19	\$ 4.9	\$ 965	\$ 990	\$ 1013	\$ 1169
Pair, Fixed Height w/Casters	AW2TLPC □	19	\$ 4.1	\$ 965	\$ 990	\$ 1013	\$ 1169

Nesting T-Legs

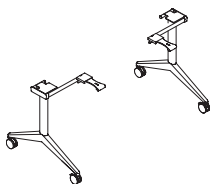

For 30"D x 66"W Polygon Top							
48"W Kit, Fixed Height w/Casters	AW2TL36N48C □	26	\$ 6.5	\$ 1507	\$ 1534	\$ 1557	\$ 1728
For 30"D x 85"W Crescent Top							
54"W Kit, Fixed Height w/Casters	AW2TL30N54C □	26	\$ 6.8	\$ 1526	\$ 1553	\$ 1576	\$ 1752

Fixed V-Legs

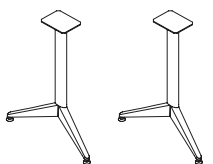

For 24"D x 55"W Polygon or 24"D x 70"W Crescent Tops							
Pair, Fixed Height w/Glides	AW2VMPG □ (shown)	18	\$ 3.5	\$ 1067	\$ 1092	\$ 1115	\$ 1269
Pair, Fixed Height w/Casters	AW2VMPC □	18	\$ 2.4	\$ 1067	\$ 1092	\$ 1115	\$ 1269

Nesting V-Legs

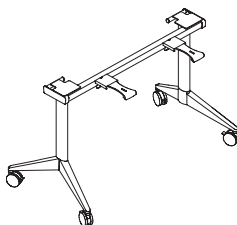

For 24"D x 70"W Crescent Top							
36"W Kit, Fixed Height w/Casters	AW2VM18N42C □	24	\$ 4.5	\$ 1535	\$ 1562	\$ 1585	\$ 1756
For 24"D x 55"W Polygon Top							
36"W Kit, Fixed Height w/Casters	AW2VM30N42C □	24	\$ 6.3	\$ 1598	\$ 1625	\$ 1648	\$ 1823

<p><i>How to specify —</i></p> <p>Select the Model Number from above.</p> <p>Add suffix: B for Painted S for Polished</p>	<p><i>1st Option:</i></p> <p>Paint Color or PAL for Polished:</p> <p>P1 P2 P3</p> <p>See page 458 for finishes.</p>	<p><i>2nd Option:</i></p> <p>Laminate:</p> <p>Caster Color (if applicable):</p> <p>B Black S Silver</p>
AW2 . .		

Examples: AW2TLPGB.P7B AW2TL36N48CS.PAL.S

S Shippable by small-package carrier.

Modesty Panels:

- 9¼"H x ½"D.
- Modesty panel must be removed from tables prior to folding.
- Tables may be nested with modesty panel attached to table. Nesting depth of additional tables does not increase.
- Modesty panel is undersized by 9¾" from width of table top.
- Nesting V-leg models require one size smaller modesty panel than T-leg. Example: 42"W Nesting V-leg table requires AW4HM36. See below.

Universal Hook

Mounts to underside of worksurface and provides storage for bags, coats and purses. Hooks can be used as a horizontal wire manager under worksurface.

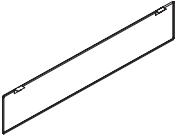

Ganging Bracket

- One-step tool-free operation.
- Tables have pre-drilled holes for proper installation and alignment of ganging mechanism.
- Includes two ganging links and two screws. Recommend one package of 2 brackets per table.
- Ganging brackets will not work with knife edge surfaces.



Description	Model	Ship Weight	Cubes	P1 Paint List Price	P2 Paint List Price	P3 Paint List Price
Hinged Metal Modesty Panels for Aware Tables with T-Legs						
26½"W — for 36"W table with T-Legs	AW4HM36	8	1.7	\$ 341	\$ 353	\$ 361
32½"W — for 42"W table with T-Legs	AW4HM42	9	1.9	\$ 357	\$ 369	\$ 377
38½"W — for 48"W table with T-Legs	AW4HM48	11	2.2	\$ 384	\$ 396	\$ 404
44½"W — for 54"W table with T-Legs	AW4HM54	12	2.5	\$ 403	\$ 415	\$ 423
50½"W — for 60"W table with T-Legs	AW4HM60	14	3.1	\$ 432	\$ 444	\$ 452
56½"W — for 66"W table with T-Legs	AW4HM66	16	3.1	\$ 473	\$ 485	\$ 493
62½"W — for 72"W table with T-Legs	AW4HM72	17	3.7	\$ 536	\$ 548	\$ 556
74½"W — for 84"W table with T-Legs	AW4HM84	20	4.4	\$ 599	\$ 611	\$ 619
86½"W — for 96"W table with T-Legs	AW4HM96	21	4.4	\$ 639	\$ 651	\$ 659

Description	Model	Ship Weight	Cubes	P1 Paint List Price	P2 Paint List Price	P3 Paint List Price
Hinged Metal Modesty Panels for Aware Tables with V-Legs						
26½"W — for 42"W table with V-Legs	AW4HM36	8	1.7	\$ 341	\$ 353	\$ 361
32½"W — for 48"W table with V-Legs	AW4HM42	9	1.9	\$ 357	\$ 369	\$ 377
38½"W — for 54"W table with V-Legs	AW4HM48	11	2.2	\$ 384	\$ 396	\$ 404
44½"W — for 60"W table with V-Legs	AW4HM54	12	2.5	\$ 403	\$ 415	\$ 423
50½"W — for 66"W table with V-Legs	AW4HM60	14	3.1	\$ 432	\$ 444	\$ 452
56½"W — for 72"W table with V-Legs	AW4HM66	16	3.1	\$ 473	\$ 485	\$ 493
68½"W — for 84"W table with V-Legs	AW4HM78	20	4.4	\$ 578	\$ 590	\$ 598
80½"W — for 96"W table with V-Legs	AW4HM90	21	4.4	\$ 630	\$ 642	\$ 650

Description	Model	Ship Weight	Cubes	List Price
Universal Hook (Black only)				
Package of 2	AGSAUHK	3	0.2	\$ 132
Ganging Bracket				
Bracket includes Hardware	AW4GANG	0.2	0.0	\$ 101

<p>How to specify — Select the Model Number from above.</p>	<p>1st Option: Paint Color (if applicable):</p> <p>P1 P2 P3</p>
--	---

Examples: AW4HM60.P27 AW4HM42.PJW AW4GANG

 Shippable by small-package carrier.

Laptop Drawer

- Drawer body made of sheet metal.
- Drawer front made of 3/4" particleboard with laminate on both sides and fused laser edge banding.
- Core removable lock is located on right side drawer front
- 17 7/8" W x 18" D x 3 3/8" H Outside (interior 13" W x 16" D x 1 7/8" H)
- Minimum surface depth is 21" for surfaces not using an external stiffener; and 27" for surfaces using an external stiffener.
- Drawer extends 16"
- Maximum load: 45 lbs (functional BIFMA load)
- Drawer assembly and cover have cut out in back to allow for cables to exit drawer.
- Distance from floor to bottom of unit w/ glides fully retracted is 24 3/4".
- Can be used with rabbet edge worksurface models but there will be a larger reveal between surface and drawer.
- Can be used with knife edge worksurface models but reveal and depth need to be considered.

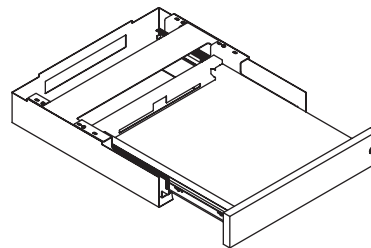

Aware®

Front View

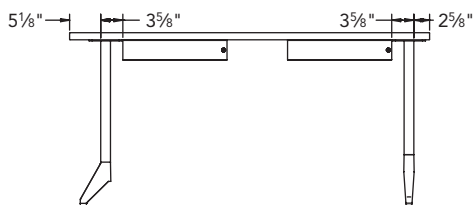

Top View

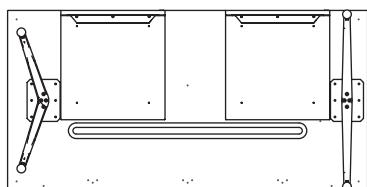

Aware Tables

- Can only be used on 30" deep surfaces due to interference with internal stiffener.
- Can only be used with fixed legs; no nesting or folding legs.
- Cannot be used with an external stiffener.
- T-legs- drawer must be offset from worksurface edge by edge to leg distance + 3/4" to clear leg mounting plate.
- V-legs- drawer must be offset from worksurface edge by edge to leg distance + 3/4" to clear leg mounting plate
- See illustrations at left.

Not on Merge® or Altitude® Tables

- Cannot be used with Merge tables due to interference with internal stiffener; and Altitude tables due to interference with external stiffener.

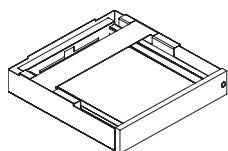

GSA SIN 33721

Description	Model	List Price		
		P1 Paint	P2 Paint	P3 Paint
Laptop Drawer - Locking, laminate front, metal case				
17 7/8" W x 18" D x 3 3/8" H (Interior 13" W x 16" D x 1 7/8" H)	U7WDA 5	\$ 1750	\$ 1773	\$ 1792

<p>How to specify — Select the Model Number from above.</p> <p>U .</p>	<p>1st Option: Laminate (Drawer front if applicable): See page 458 for finishes.</p> <p> .</p>	<p>2nd Option: Edge (Drawer edge if applicable): See page 458 for finishes.</p> <p> .</p>	<p>3rd Option: Paint (If drawer, list exterior case color here): See page 458 for finishes.</p> <p> .</p>	<p>4th Option: Paint (Interior Drawer if applicable): See page 458 for finishes.</p> <p> .</p>	<p>5th Option: Lock (if applicable): STD Standard OMT Omit Lock Core (Deduct \$20)</p> <p> .</p>	<p>6th Option: Lock Color (if applicable): EL Silver</p> <p> .</p>
---	---	--	--	---	---	--

Example: U7WDA.LM11EV.P27.PR6.STDEL

5 Shippable by small-package carrier.

Wire Trough

- Accepts cords for routing
- Wire trough adheres and screws to underside of table surface

Wire Manager Covers

- Attaches to leg and conceals power, voice, and data cables.
- Will not work on large T folding legs.
- Cable capacity shown on page 462.



Power/Data Ports

- Corded has 10' cord and plug.
- Hardwire has 10' cord.

Interlink IQ Electrical Modules

- Pluggable, single circuit electrical system
- UL recognized as a powered table system and meets the requirements of UL 962
- Interlink IQ modules require a minimum of one Interlink IQ starter.
- A maximum of 8 Interlink IQ power modules (including jumpers) can be “daisy chained” together in any combination off of one 15-amp infeed starter.

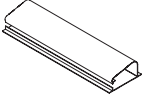
- System status indicator:
 - Red light indicates too many units connected
 - Green light indicates appropriate use
- All models include wire management clips and hardware
- Power harness includes 60" cord and 11" tail. Daisy chained tables in line over 60" W require 36" jumper between modules.

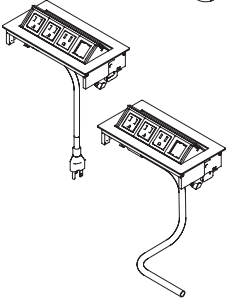
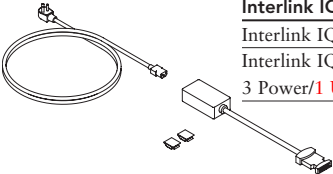
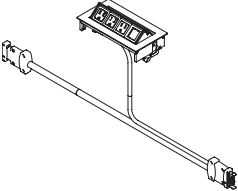
	Description	Model	Ship Weight	Cubes	List Price	
	Wire Trough (Black only)					
	17¼"W Trough for 48"W and shorter Tables	AW4W48 <i>(De-emphasized)</i> S	2	0.2	\$ 101	
	34"W Trough for 54"W or 60"W Tables	AW4W60 S	3	0.4	\$ 181	
	42¼"W Trough for 66"W or 72"W Tables	AW4W72 <i>(De-emphasized)</i> S	5	0.4	\$ 224	
	58"W Trough for 84"W or 96"W Tables	AW4W84 <i>(De-emphasized)</i> S	5	0.9	\$ 289	
	Wire Manager Covers					
	For small T (AW2TS prefix) and medium V (AW2VM prefix) leg models	AWCVRG S	5.0	4.1	\$ 189	
	For large T (AW2TL prefix, except folding) and caster models	AWCVRC S	5.5	4.1	\$ 189	
	Power/Data Ports					
	Power Harness Corded – 3 AC / 1 Open Data	AW4P2C S	3	1.9	\$ 626	
	Power Harness Hardwired – 3 AC / 1 Open Data	AW4P2H S	3	1.9	\$ 626	
	Interlink IQ Electrical Modules					
	Interlink IQ Starter with 72" Infeed cord	AW4QBI S	2	0.2	\$ 853	
	Interlink IQ Power Harness — 3 Power/1 USB-A, 1 USB-C/2 OpenWindows	AM4QH3P1U2B	5	0.2	\$ 1348	
	Interlink IQ 60" Power Harness with Pop-Up — 3 AC / 1 Open Data	AW4QH60P S	3	1.9	\$ 606	
	Interlink IQ 36" Jumper	AW4QJ36 S	2	0.2	\$ 171	
	Interlink IQ 36" Backward Compatible Jumper*	AW4QBCJ36	2	0.2	\$ 171	
	*Must order to connect new interlink IQ components to existing installs.					

<p>How to specify — Select the Model Number from above.</p>	<p><i>1st Option:</i> Paint Color <i>(if applicable):</i></p> <p>FOG Fog SVR Silver BLK Black</p>
<p>AW </p>	<p> </p>

Examples: AW4W48 AW4P2CF.FOG AW4QBI

S Shippable by small-package carrier.

Technology Modules

- Can be mounted by clamping to worksurface or mounting flush to the worksurface top.
- The USB hub allows simultaneous powering of four USB-A devices.
- Technology Modules have 10' cords.
- Opening size needed to flush mount in worksurface.

Worksurface Power/Data Module

- Provides easy access to technology at primary worksurface.
- Mounts to edge of a worksurface and requires 3/8" gap. Consider whether 3/8" gap will work with layout.

Model	Depth of Cut	Width of Cut
A87P2U1R	4"	8"

	Description	Model	List Price
	Technology Modules — Flush Mount (EL Silver only)		
	2 Power, 1 USB-A, 1 USB-C	A87P2U1R S	\$ 1130
	Worksurface Power/Data Module (PR6 Silver only)		
	2 Simplex receptacles, 1 data position	A870302	\$ 395

<p>How to specify — Select the Model Number from above.</p>	<p><i>1st Option:</i> Technology Module Color: EL Silver</p>
--	---

E | L

Examples: A87P2U1R.EL A870302

S Shippable by small-package carrier.

- 2- and 3-Bay credenzas ship fully assembled.
- Available in solid and woodgrain laminate colors. You can select one laminate for the case and a second laminate for the front doors and back panels. Credenza top including front edge is the same color as the case.
- Painted mesh in Designer White, Flint, or Silver at top and bottom of the front and back sides of unit provides passive ventilation.
- Edge guards on mesh and wire manager protects cords and fingers.
- Grommet models feature square Silver metal grommet.
- Six leveling glides on 72"W, four glides on 48"W. Leveling range is 1".
- Credenzas are constructed from ¾" thick high-pressure laminated particleboard with 1 mm edge banding and European cam-and-pin construction.
- Units are shipped with either lock cores removed or as non-locking. Core removable lock option allows key numbers to be easily changed in the field. Cores available in the Casegoods & Storage price list on page 65. Note: Middle cabinet on 3-Bay units do not lock.
- Shelves are painted metal. Base shelves are secured, except center shelf in 72"W credenza.
- Interior bay dimensions are 22"W x 28½"H x 22⅜"D. Secured bottom shelves are 19"D to account for ventilation and wire management. Rated for 50 lbs.
- Removable back(s) snap on for easy component installation.
- Bottom wire management channel runs entire width of credenza.
- Optional top hung drawers (8½"H) use full extension slides; limit of one drawer per bay. Drawers cannot be used in same bay with AV rack, waste pullout, and will limit size of refrigerator.
- Slide out A/V storage rack features EIA spacing with twelve usable rack spaces.
- Units ship with one adjustable shelf per bay. Shelves are adjustable in 6" increments.
- Additional metal shelves are field-installed using supplied template, maximum of three per bay.

Description	Model	Ship Weight	Cubes	Solid Laminate List Price	UPCHARGES*			
					L2 Laminate Case		L3 Laminate Case	
					Front/Back	Front/Back		
Buffet Credenza — 34"H x 24"D								
72"W with Grommet / Removable Back Left and Right	AW4BC7224	336	56	\$ 9635	\$ 228	\$ 97	\$ 458	\$ 195
72"W no Grommet / Removable Back Left and Right	AW4BC7224NG	336	56	\$ 9624	\$ 228	\$ 97	\$ 458	\$ 195
48"W with Grommet /								
Removable Back Left (shown)	AW4BC4824L	235	38	\$ 7020	\$ 166	\$ 71	\$ 333	\$ 142
48"W no Grommet / Removable Back Left (shown)	AW4BC4824LNG	235	38	\$ 7008	\$ 166	\$ 71	\$ 333	\$ 142
48"W with Grommet / Removable Back Right	AW4BC4824R	235	38	\$ 7020	\$ 166	\$ 71	\$ 333	\$ 142
48"W no Grommet / Removable Back Right	AW4BC4824RNG	235	38	\$ 7008	\$ 166	\$ 71	\$ 333	\$ 142

Description	Model	Ship Weight	Cubes	List Price
Credenza Storage Drawer (Laminate front LM16 Flint only)				
Interior: 14½"W x 14¼"D x 2⅝"H Particleboard body in a metal case	AW4DRAWER	30	4.1	\$ 915
Slide Out Audio/Visual Storage Rack (Black only, not specified) Weight capacity 125 lbs.				
19¾"W x 18¾"D x 22⅝"H Metal frame with 10-32 threaded holes	AW4AVRACK	29	4.8	\$ 3314
Trash/Recycling Slide Out (Platinum only, not specified) Weight capacity 100 lbs.				
14¾"W x 22½"D x 18¾"H Comes with 2 – 35 qt bins	AW4TRASH	36	2.8	\$ 689
Metal Interior Shelf (Painted in Flint, Designer White, or Silver only)				
23"W x 21"D x 2"H Weight capacity 50 lbs.	AW4SHELF	5	1.6	\$ 246

How to specify — Select the Model Number from above.	1st Option: FSC Certified Wood (if applicable): FSC Certified X No FSC	2nd Option: Case Laminate (if applicable):	3rd Option: Matching Edge Color (if applicable):	4th Option: 2nd Laminate Color (Front) (if applicable):	5th Option: Matching Edge Color (if applicable):	6th Option: Paint Color (if applicable): PJW Designer White P02 Flint PR6 Silver (No upcharge for PR6)	7th Option: Lock (if applicable): OMT Omit Cores NL No Locks or Holes
AW4							

Examples: AW4BC7224.X.LM14EW.LWDDD.PR6.NL AW4DRAWER.LM16E9

- 2- and 3-Bay credenzas ship fully assembled.
- Available in solid and woodgrain laminate colors. You can select one laminate for the case and back, and a second laminate for the front doors. Credenza top including front edge is the same color as the case.
- Painted mesh in Designer White, Flint, or Silver at bottom of the front side of unit matches buffet credenza.
- Waste bins and inserts are not included with Recycle Credenzas. Recommend 25 gallon waste bins 17" x 17" x 28"H by Tough Guy, Rubbermaid, Continental, or Safco. Order inserts separately.
- Credenzas are constructed from ¾" thick high-pressure laminated particleboard with 1 mm edge banding and European cam-and-pin construction.
- Front plates and optional inserts are metal.
- Septums in 3-Bay units provide separation and support.
- Units come with 3 of each label with 57"W units; and 2 of each label with 36"W units. Silver and white units come with Black labels; Flint comes with White labels.
- Back is inset ⅞" for easy handling and flush fit against wall.
- Leveling glide range is 1".

Description	Model	Ship Weight	Cubes	Solid Laminate List Price	UPCHARGES*			
					L2 Laminate Case/Back	L2 Laminate Front	L3 Laminate Case/Back	L3 Laminate Front
Recycle Credenza — 40"H x 20"D (Front plate and mesh in Designer White, Flint or Silver)								
57"W Three Bays – Interior each 17"W x 28"H x 17¼"D (Shown with paper and bottle/can inserts – order separately below)	AW4WC5720	275	43	\$ 9173	\$ 218	\$ 93	\$ 434	\$ 186
36"W Two Bays – Interior 34½"W x 28"H x 17¼"D (Shown with bottle/can and paper inserts – order separately below)	AW4WC3620	180	35	\$ 6896	\$ 162	\$ 70	\$ 326	\$ 140

Description	Model	Ship Weight	Cubes	List Price	
				P1 Paint	P3 Paint
Paper Insert for Recycle Credenza (Painted metal in Designer White, Flint, Silver, Atom or Krypton)					
For 57"W Recycle Credenza	AW4WCTIP57W	3	0.5	\$ 246	\$ 267
For 36"W Recycle Credenza	AW4WCTIP36W	3	0.5	\$ 246	\$ 267
Bottle/Can Insert for Recycle Credenza (Painted metal in Designer White, Flint, Silver, Atom or Krypton)					
For 57"W Recycle Credenza	AW4WCTIBC57W	3	0.5	\$ 246	\$ 267
For 36"W Recycle Credenza	AW4WCTIBC36W	3	0.5	\$ 246	\$ 267

Description	Model	Ship Weight	Cubes	List Price
Waste Credenza Labels (Bottle/Cans, Paper, Recycle, Trash – SPECIFY Black or White)				
12 Labels — 3 of each	AW4WC57LABEL	0.1	0.1	\$ 120
8 Labels — 2 of each	AW4WC36LABEL	0.1	0.1	\$ 82

Note: Recycle Credenzas come with 3 of each label with 57"W units; and 2 of each label with 36"W units.

How to specify — Select the Model Number from above.	1st Option: FSC Certified Wood (if applicable): FSC Certified X No FSC	2nd Option: Case Laminate (if applicable):	3rd Option: Matching Edge Color (if applicable):	4th Option: 2nd Laminate Color (Front) (if applicable):	5th Option: Matching Edge Color (if applicable):	6th Option: Paint (if applicable): P8S Atom (P3 upcharge) P JW Designer White P02 Flint P8F Krypton (P3 upcharge) PR6 Silver (no upcharge)	7th Option: Label Color (if applicable): BLK Black WHT White
AW4							

Examples: AW4WC5720.X.LM14EW.LWDDD.PR6 AW4WCTIP57W.P7H

- Lectern features laminate construction with painted metal base and accents.
- Angled surface is 24"W x 11½"D with ⅜" lip at bottom.
- Removable back panel provides easy power and cord routing from bottom of unit to top.
- Recessed area at top right for water or beverage.

- Metal surface at top left, front for mounting microphone holder or light is 5"W x 7"D. Requires end-user to drill applicable holes for mounting.
- Recessed center area at top front provides room for cords and power supplies. Flip-up laminate door provides easy access and hides cords. Area has an Extron cut-out

- and two simplex cutouts for mounting two AW4LECTPWR power units below. Extron super plate unit purchased separately.
- Storage shelf below angled surface is 4"H x 24¼"W x 10"D. Cut-out at front of compartment for routing cords.
- Four 2¼" casters for mobility, all are locking for lectern to remain stationary when necessary.

Description	Model	Ship Weight	Cubes	List Price		
				L1	L2	L3
Lectern — Laminate and Painted Metal						
Technology Ready 26"W x 19"D x 43¾"H	AW4LECT	170	32	\$ 5313	\$ 5494	\$ 5674

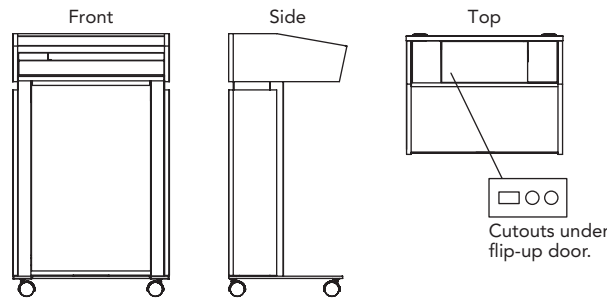
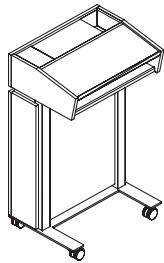

Description	Model	Ship Weight	Cubes	List Price
Lectern Power Unit — White or Black				
Single AC power unit, bracket, and 6' cord w/plug	AW4LECTPWR	0.9	1.6	\$ 169

<p>How to specify — Select the Model Number from above.</p>	<p><i>1st Option:</i> FSC Certified Wood (if applicable): FSC Certified X No FSC</p>	<p><i>2nd Option:</i> Laminate (if applicable): See page 458 for finishes.</p>	<p><i>3rd Option:</i> Edge Color (if applicable): See page 458 for finishes.</p>	<p><i>4th Option:</i> Paint (if applicable): P JW Designer White P O2 Flint P R6 Silver (No upcharges)</p>	<p><i>5th Option:</i> Electrical (if applicable): B LK Black W HT White</p>
<p>AW4LECT</p>					

Examples: AW4LECT.X.LWDDD.PR6 AW4LECT.FSC.LM13EY.PR6 AW4LECTPWR.BLK

Setting the table for change.

Today's corporate training room can take many forms, including lectures, brainstorms, and breakouts – sometimes requiring multiple transformations in a single day. Whether you're planning for an hour-long meeting or an aggressive all-day agenda with various room changes, the Aware collection can easily create the space you need right now and adapt to create the space you'll need in a few hours.

Aware Kit-of-Parts in Typical Below

Line	Qty	Model Number	Description
1	1	AW4WC5720	40"H x 57"W x 20"D Recycle Credenza
2	2	AW4BC7224NG	34"H x 72"W x 24"D Buffet Credenza – No Grommet
3	4	AW4WB4896P	48"H x 96"W Wall Hung Marker Board – Porcelain
4	8	AW4MB7236P	72"H x 36"W Mobile Marker Board – Porcelain
5	13	AW3LF2460V	24"D x 60"W Aware Top Lam Flat Edge
6	13	AW2VM24N60CS	Aware 24"D x 60"W Nesting V-Leg – Polished w/Caster
7	12	AW3LFT2460T	24"D x 60"W Aware Trapezoid Top Laminate Flat Edge
8	12	AW2TS24N42CB	Aware 24"D x 42"W Nesting T-Leg – Polished w/Caster
9	2	AW3LFH2448V	24"D x 48"W Aware Half-Round Top Laminate Flat Edge
10	2	AW2VM24N36CB	Aware 24"D x 36"W Nesting V-Leg – Polished w/Caster

Seating, Structure, and Social Collaborative Kit-of-Parts In Typical Below

Line	Qty	Model Number	Description
11	50	K-MUCOSNO	Seek Work Fixed Arms Mesh Back Upholstered Seat
12	1	AMPTLF36RND	36" Dia. Round Top, Laminate, Flat Edge
13	1	MLM4S	58"W Recharge Double with Double Bolster
14	1	MLM5S	58"W Recharge Double with Straight Screen
15	1	S914CWS	Counterweight for 23" dia. base All-Around
16	1	AMPTPR26M	Medium-Round Pedestal Base – Continental Height
17	2	EPR18S	Two Thirds Pouf
18	2	S921B2CL	Hedge w/Base 10" Laminate Tablet – Double
19	2	S922S2TOC	Two-Tone – 2 Tier Outside Corner Rise
20	2	S922S2	Rise – 2 Tier

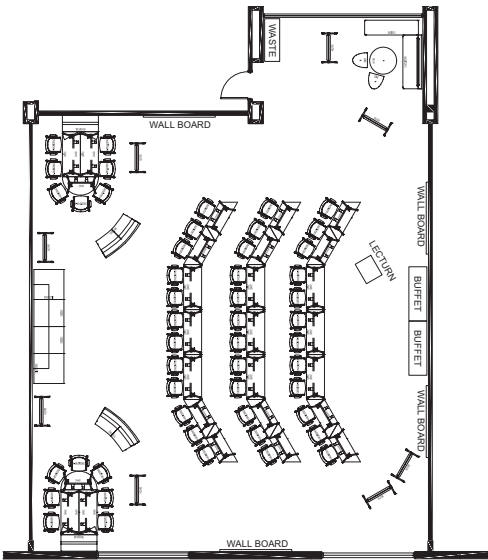

9:00 am

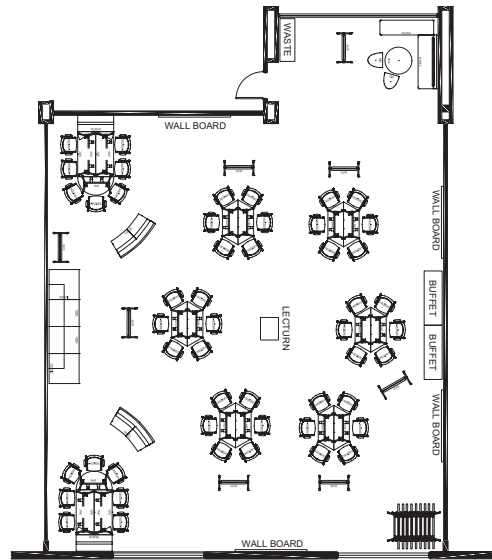

12:00 pm

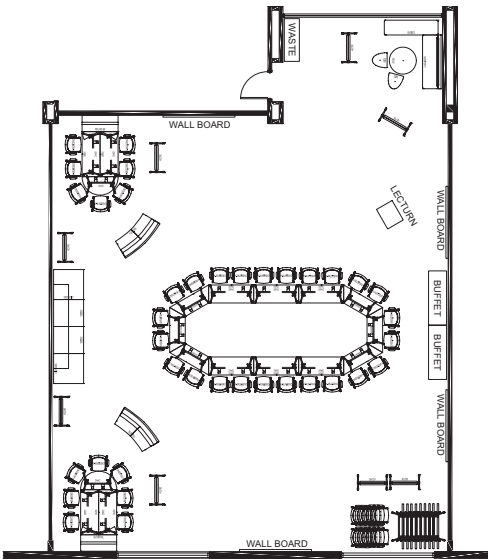

3:45 pm

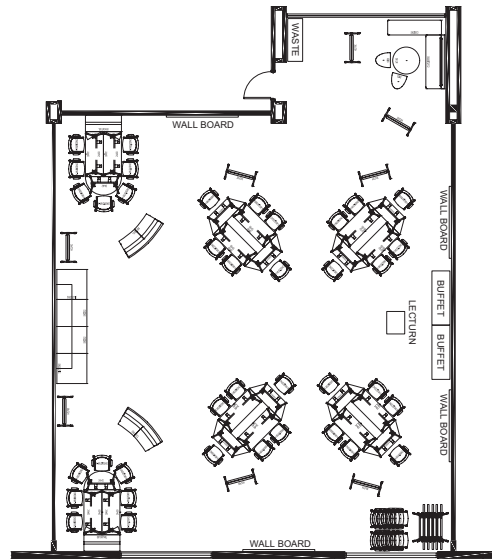

7:00 pm

HARVEST PAINT FINISHES

GRADE P1

Black.....	P27
Brownstone.....	P7D
Bungalow.....	P7C
Cinder.....	P7Q
Designer White.....	PJW
Flint.....	P02
Loft.....	P7B
Muslin.....	P4J
Pebble.....	P8R
Pewter.....	P8D
Salt.....	P8C
Titanium.....	P8T

GRADE P2

Champagne Metallic.....	PR5
Designer White 65 High Gloss.....	P8W
Gunmetal Metallic.....	PR3
Night Bronze.....	P8B
Platinum Metallic.....	PR2
Pyrite.....	PJE
Silver.....	PR6
Solar Black.....	P8X

GRADE P3

Atom.....	P8S
Blossom***.....	P8K
Bullseye.....	PJF
Cabernet***.....	P7T
Conifer***.....	P8H
Ember.....	P8P
Ion.....	P8N
Iris.....	P8J
Krypton.....	P8F
Regatta.....	P8M
Succulent***.....	P8A

These colors are intended to be an inspirational option for the trending market. Product application is limited and color availability is approximately two years to coincide with evolving workplace trends.

Metallic paints, due to varying reflectance, may appear to have less visual color consistency than other paint finishes, even when L/A/B values are exactly the same. (L/A/B — measurable aspects of color — values are maintained within a specified range, to ensure consistent appearance of paint colors.)

HARVEST RUSTIC WOOD LEG & PLANK TOP FINISHES

Dark Brown.....	LL897
Light Neutral.....	LL815
Medium Grey.....	LL814

HARVEST LAMINATES

GRADE L1

CORE SOLID COLORS**

Black.....	P
Brownstone.....	LM13
Bungalow.....	LM12
Designer White.....	LDW1
Flint.....	LM16
Loft.....	LM11
Muslin.....	LM15

WOODGRAIN

Belair.....	LWBA
Bourbon Cherry.....	H
Field Elm.....	LWFE
Florence Walnut.....	LFW1
Kingswood Walnut.....	LK11
Natural Maple.....	LWD
NeoWalnut.....	LNU1
Pinnacle.....	PINC
Shaker Cherry.....	LW7C

GRADE L2

Beigewood.....	LWBE
Fawn Cypress.....	LFC1
Lowell Ash.....	LLA1
Mangalore Mango.....	LMM1
Natural Recon.....	LNR1
Phantom Charcoal.....	LPC1
Phantom Ecu.....	LPE1
Portico Teak.....	LPT1
Skyline Walnut.....	LSW1
Veranda Teak.....	LVT1

GRADE L3

Natural Walnut.....	LWNW
---------------------	------

**144"L and 168"L (2 piece) Tops are limited to solid color laminates and edge colors.

HARVEST LAMINATE EDGE COLORS

Edge colors are predetermined based on matching laminate selection.

Beigewood.....	DE
Belair.....	BA
Black.....	E4
Bourbon Cherry.....	H
Brazilwood.....	DB
Brownstone.....	EY
Bungalow.....	EX
Designer White.....	DW
Fawn Cypress.....	LF
Field Elm.....	FE
Flint.....	E9
Florence Walnut.....	FW
Kingswood Walnut.....	KI
Loft.....	EV
Lowell Ash.....	DL
Mangalore Mango.....	MM
Muslin.....	EU
Natural Maple.....	DD
Natural Recon.....	NR
Natural Walnut.....	DN
NeoWalnut.....	NU
Phantom Charcoal.....	EC
Phantom Ecu.....	PE
Pinnacle.....	PI
Plyband ♦.....	PL
Portico Teak.....	DP
Shaker Cherry.....	DF
Skyline Walnut.....	SW
Veranda Teak.....	VT

♦ Edge is limited to flat edge surfaces: rectangle, square, trapezoid, polygon, or round. No curvilinear or combination curve and straight. No T-Mold.

HARVEST VENEERS

STRATAWOOD

GRADE V2

Add FSC prefix to Stratawood and Natural veneer codes listed below for FSC finishes on Harvest.

Example: FSCSC777

CHERRY

Cinnamon/Biltmore Cherry.....	SC260
Lowell Ash Cherry.....	SC394
Clear Cherry.....	SC700
Light Cherry.....	SC701
Shaker Cherry.....	SC774
Burnished Cherry.....	SC777

MAPLE

Field Elm.....	SE599
Clear Maple.....	SE800
Harvest Maple.....	SE856
Beigewood.....	SE878
Phantom Ecu.....	SE912
Belair.....	SE934

OAK

Clear Oak.....	SE300
Dark Rift Cut Oak.....	SE331

SILVER OAK

Clear.....	SB100
Portico Teak.....	SB150

WALNUT

Florence Walnut.....	ST579
Light Walnut.....	ST601
Skyline Walnut.....	ST625
Pinnacle Walnut.....	ST679
Sumatra Walnut.....	ST693

NATURAL — FLAT CUT

GRADE V2

CHERRY

Cinnamon/Biltmore Cherry.....	NC260
Lowell Ash.....	NC394
Medium Red Cherry.....	NC512
Light Cherry.....	NC701
Shaker Cherry.....	NC774
Burnished Cherry.....	NC777

MAPLE

Clear/Natural Maple.....	NE800
Harvest Maple.....	NE856

WALNUT

Ebony Walnut.....	NT509
Florence Walnut.....	NT579
Light Walnut.....	NT601
Skyline Walnut.....	NT625
Nutmeg Walnut.....	NT629
Pinnacle Walnut.....	NT679
Sumatra Walnut.....	NT693

NATURAL — RIFT CUT

GRADE V3

Fawn Cypress Rift Cut Oak.....	RF108
Light Rift Cut Oak.....	RF301
Dark Rift Cut Oak.....	RF331
Phantom Ecu Rift Cut Oak.....	RF912

Horizontal surfaces to be full-fill, ClearTech finish.

The beauty of wood is the natural variation of grain patterns and colors that make each piece unique. This variation is also influenced by lighting conditions, orientation of mated parts, and varying acceptance of the finishing process. The varying colors and physical characteristics naturally occur in all wood species but are most pronounced in lighter colored woods, and are especially evident in natural finishes.

NOTE: Refer to individual product pages for upcharges.

FSC Certified Wood at Allsteel

See page 459 for more information.

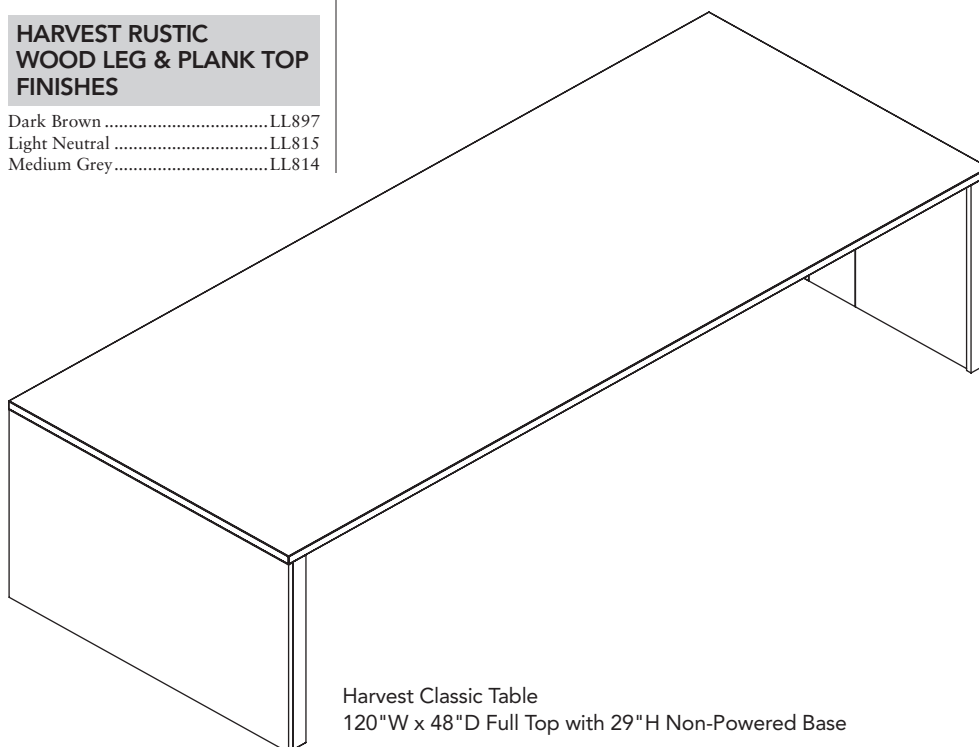

Harvest Classic Table
120"W x 48"D Full Top with 29"H Non-Powered Base

Harvest brings all the collaborative potential of a multi-purpose table to the corporate environment. It's welcoming. Useful. It invites conversation and interaction whenever people meet up. So it's easy to Harvest the best ideas.

MODELS AND OPTIONS

Select the seated table height models for meeting and conference rooms or touchdown areas. Or specify a standing-height version for project spaces or cafés. Harvest Classic includes an optional split top that facilitates cord management and power/data hubs that allow for easy access to technology. The sliding doors in the technology trough not only provide easy access to cords from below, but are painted to add an accent color to the space. A solid top can be specified when technology access isn't as critical. Harvest tables are available in laminate or veneer.

APPLICATIONS

Place Harvest tables in cafés, atrium spaces, libraries, open-plan areas, and conference rooms.

KEY FEATURES

Harvest Classic tables are offered in a variety of sizes with power and data capability. Inspired by gathering spaces where people like to talk and share, like the dining room table or coffee area in the office, it invites conversation and interaction whenever people meet up.

TABLE CAPACITIES

Table Top	Seating Capacity
72"W x 36"D	4
72"W x 42"D	4
72"W x 48"D	4
96"W x 36"D	6
96"W x 42"D	6
96"W x 48"D	6
120"W x 36"D	8
120"W x 42"D	8
120"W x 48"D	8

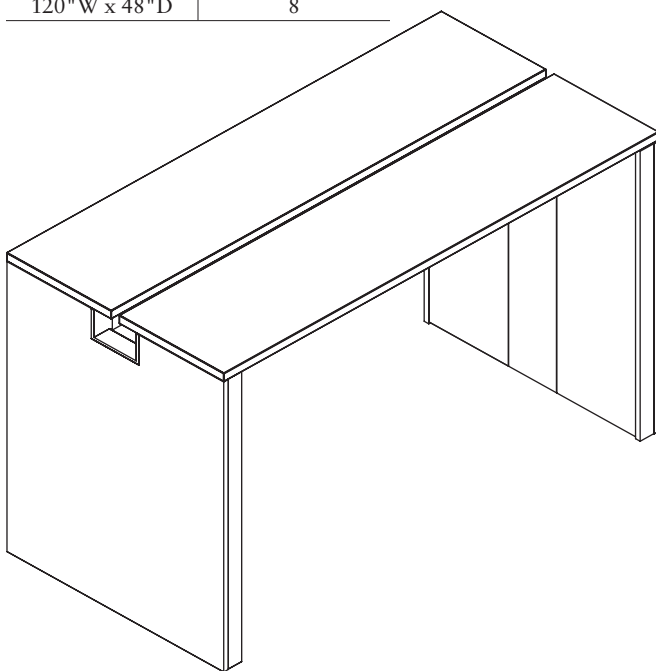

72"W x 36"D Split Top with 42"H Powered End Panel Base

MATERIALS AND FINISHES

Laminate Edge



Flat Edge

Veneer Edge

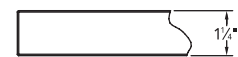
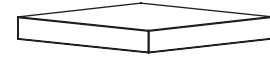

Square Edge

CLEARANCE DIMENSIONS

Between Bases

End panel bases are 3" D making clearance between bases 6" less than the width of top:

- 72"W top has 66" clearance
- 96"W top has 90" clearance
- 120"W top has 114" clearance

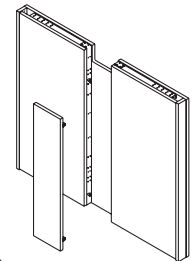

End Panel Bases

All end panel bases have a hidden center channel 7"W x 1½" D for routing cables from floor to trough. The end panel access door can be mounted flush to bottom for a clean aesthetic or rotated to provide a one-half inch offset to allow for additional cord and cable clearance.

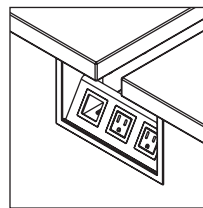

Powered end panel models feature cutouts for mounting a power/data hub and align with end panel center channel and the technology trough of top. Full tops (without split) can be used with powered end panels. Cutout is finished with a PR6 Silver bezel.

Split Tops

Split tops provide a 1¼" gap for routing cords and power adapters. Inside technology trough dimensions are 7"W x 3¾"D.

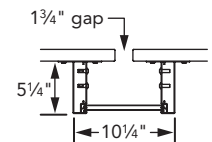

Wire Trough and Beam

A recessed wire trough runs the length of all table tops. It is accessible through three sliding doors on the under side. Sliding doors can be easily removed for cleaning.

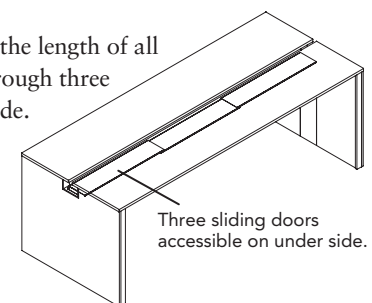

Center trough with beam is 10¼" wide and extends 5¼" below top. Clearance under top and under trough:

- 29"H End Panels provide 28¾"H / 23"H
- 42"H End Panels provide 40¾"H / 35½"H

Distance from front edge of surface to trough:

- 36"D Top is 12⅞"D
- 42"D Top is 15⅞"D
- 48"D Top is 18⅞"D

ELECTRICAL OPTIONS

Harvest Classic Tables offer three power options: Corded, Interlink IQ, or Hardwire. Installation and use of electrical systems, the number of receptacles used on a given circuit and connections to the building power supply should be in compliance with all local and national electrical codes. See matrix on page 496 for suggested cord length requirements. Verify code requirements before ordering. Chicago requires hard wiring. Chicago and New York do not permit use of Interlink IQ components.

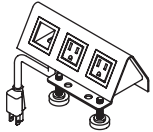

Corded

Corded models plug directly into an outlet and can be mounted back-to-back. Corded modules cannot plug into other corded power modules. In order to plug into other units the unit would need to be hardwired. When routing corded models to a wall outlet, the maximum amount of cord that can be exposed outside of the furniture is 6 feet. (New York, check local code.)

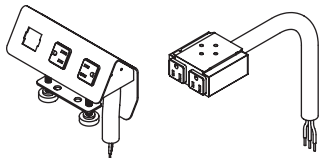

Hardwire

Hardwire models are provided with 20' of sealtight cable. Customer must furnish junction boxes, conduit, and additional wire to be in compliance with local and national electrical codes. Hardwire surface mounted modules cannot mount back-to-back and require units to be mounted side-by-side (see below).

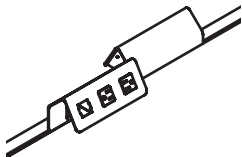

Interlink IQ

Interlink IQ provides the ability to use one 12-amp infeed starter and power up to 8 power modules (including jumpers)

off of one infeed starter. Interlink IQ provides a visual indicator of system status. LED illuminates green when you are connected and ready to plug in. A red light indicates you have linked too many units.

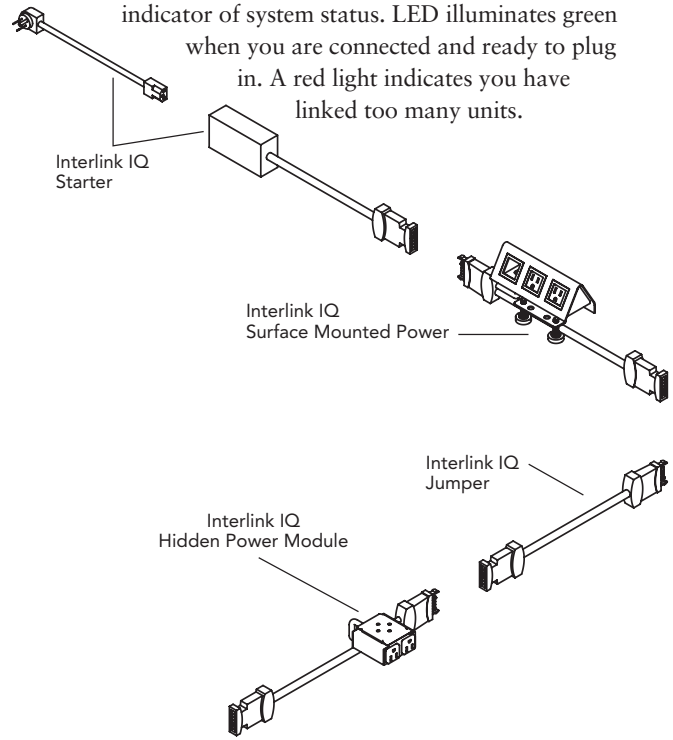

Interlink IQ Examples:

- Example #1** – 120" Harvest Classic table with full top, power needed in end panels
- (1) **S913P06LS** – 6' Interlink IQ starter
 - (2) **S913PLE** – Interlink IQ end panel power module
 - (1) **S913P05LJ** – Interlink IQ Jumper
- Example #2** – Two 120" Harvest Classic tables with split tops, power needed in end panels and throughout table
- (1) **S913P06LS** – 6' Interlink IQ starter
 - (2) **S913PLE** – Interlink IQ end panel power module
 - (4) **S913PLM** – Interlink IQ surface mounted power module
 - (2) **S913HPLE** – Interlink IQ Hidden power module

Harvest Classic Electrical Routing

HARVEST

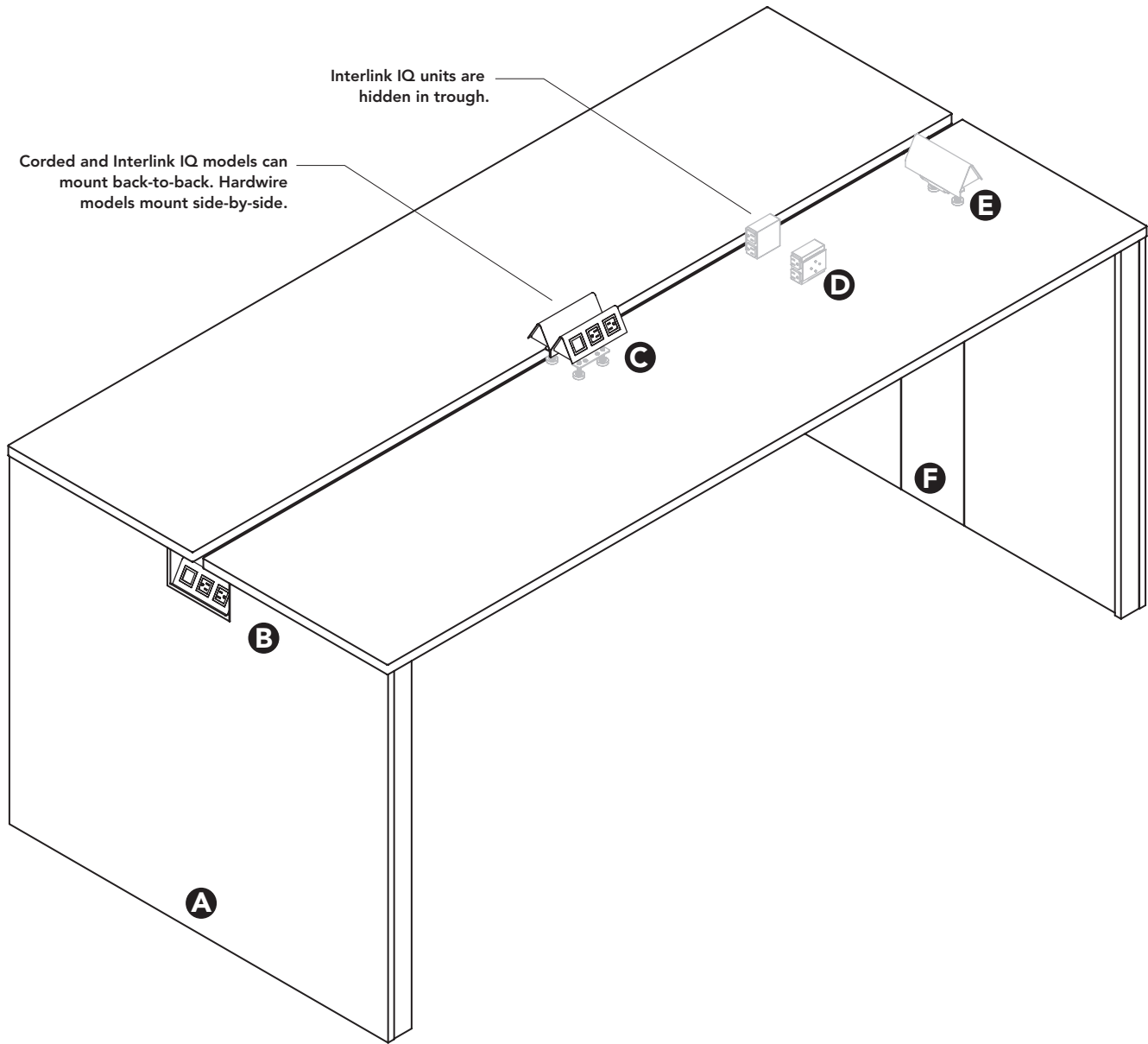

Harvest Electrical Cable Length Routing Matrix Add length from "A" or "F" to power source to dimension below.

Table Width:	Any	72" Wide Top				96" Wide Top				120" Wide Top			
Routing Paths: <i>(Reference illustration above)</i>	A to B	A to C	A to D	A to E	F to D	A to C	A to D	A to E	F to D	A to C	A to D	A to E	F to D
	F to E	F to C		F to B		F to C		F to B		F to C		F to B	
Table Height:	29½"H	66"	84"	102"	48"	78"	102"	126"	54"	90"	120"	150"	60"
	42"H	78"	96"	114"	60"	90"	114"	138"	66"	102"	132"	162"	72"

General Rules

- Corded power modules cannot plug into other corded power modules. Corded modules can plug into hardwired modules.
- Corded power running to a wall outlet is limited to 6' of cord exposed outside of the furniture. (New York, check local code)
- An Interlink IQ Starter is required for Interlink IQ components and can support a maximum of 8 power modules (including jumpers) in any combination.
- Chicago requires hardwire. Interlink IQ can not be used in Chicago or New York.

- All models below include rectangle top and beams with bottom access sliding doors to create a technology trough. Order the same depth end panel bases separately on page 498.
- Laminate tops have a flat edge that is color coordinated. Veneer tops have a matching square edge.
- Beams with sliding doors are painted metal and available in P1, P2, or P3 paint colors.

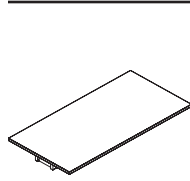

Full Top

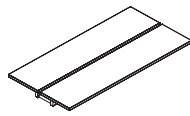

Split Top

Description	Model	Ship Weight	Cubes	List Price		
				L1 or V2	L2 or V3	L3
36"D Harvest Classic Table Tops — includes Beams and Sliding Doors						
72"W Laminate Top — Full	S913LTF3672	145	0.0	\$ 2102	\$ 2138	\$ 2167
72"W Laminate Top — Split	S913LTS3672	145	0.0	\$ 2506	\$ 2554	\$ 2600
72"W Veneer Top — Full	S913WTF3672	145	0.0	\$ 3131	\$ 3416	—
72"W Veneer Top — Split	S913WTS3672	145	0.0	\$ 3547	\$ 3869	—
96"W Laminate Top — Full	S913LTF3696	178	0.0	\$ 2536	\$ 2578	\$ 2615
96"W Laminate Top — Split	S913LTS3696	178	0.0	\$ 2944	\$ 2998	\$ 3052
96"W Veneer Top — Full	S913WTF3696	178	0.0	\$ 3648	\$ 3980	—
96"W Veneer Top — Split	S913WTS3696	178	0.0	\$ 4062	\$ 4431	—
120"W Laminate Top — Full	S913LTF3620	212	0.0	\$ 3326	\$ 3381	\$ 3439
120"W Laminate Top — Split	S913LTS3620	212	0.0	\$ 3730	\$ 3800	\$ 3874
120"W Veneer Top — Full	S913WTF3620	212	0.0	\$ 4936	\$ 5385	—
120"W Veneer Top — Split	S913WTS3620	212	0.0	\$ 5348	\$ 5834	—

42"D Harvest Classic Table Tops — includes Beams and Sliding Doors						
72"W Laminate Top — Full	S913LTF4272	158	0.0	\$ 2303	\$ 2345	\$ 2382
72"W Laminate Top — Split	S913LTS4272	158	0.0	\$ 2711	\$ 2765	\$ 2819
72"W Veneer Top — Full	S913WTF4272	158	0.0	\$ 3547	\$ 3869	—
72"W Veneer Top — Split	S913WTS4272	158	0.0	\$ 3963	\$ 4323	—
96"W Laminate Top — Full	S913LTF4296	195	0.0	\$ 2739	\$ 2786	\$ 2832
96"W Laminate Top — Split	S913LTS4296	195	0.0	\$ 3146	\$ 3206	\$ 3267
96"W Veneer Top — Full	S913WTF4296	195	0.0	\$ 4062	\$ 4431	—
96"W Veneer Top — Split	S913WTS4296	195	0.0	\$ 4475	\$ 4882	—
120"W Laminate Top — Full	S913LTF4220	234	0.0	\$ 3527	\$ 3589	\$ 3654
120"W Laminate Top — Split	S913LTS4220	234	0.0	\$ 4136	\$ 4214	\$ 4293
120"W Veneer Top — Full	S913WTF4220	234	0.0	\$ 5348	\$ 5834	—
120"W Veneer Top — Split	S913WTS4220	234	0.0	\$ 5764	\$ 6288	—

48"D Harvest Classic Table Tops — includes Beams and Sliding Doors						
72"W Laminate Top — Full	S913LTF4872	171	0.0	\$ 2506	\$ 2553	\$ 2599
72"W Laminate Top — Split	S913LTS4872	171	0.0	\$ 2913	\$ 2973	\$ 3034
72"W Veneer Top — Full	S913WTF4872	171	0.0	\$ 3963	\$ 4323	—
72"W Veneer Top — Split	S913WTS4872	171	0.0	\$ 4374	\$ 4772	—
96"W Laminate Top — Full	S913LTF4896	213	0.0	\$ 2944	\$ 2997	\$ 3051
96"W Laminate Top — Split	S913LTS4896	213	0.0	\$ 3349	\$ 3416	\$ 3483
96"W Veneer Top — Full	S913WTF4896	213	0.0	\$ 4475	\$ 4882	—
96"W Veneer Top — Split	S913WTS4896	213	0.0	\$ 4891	\$ 5336	—
120"W Laminate Top — Full	S913LTF4820	255	0.0	\$ 3730	\$ 3798	\$ 3871
120"W Laminate Top — Split	S913LTS4820	255	0.0	\$ 4136	\$ 4221	\$ 4305
120"W Veneer Top — Full	S913WTF4820	255	0.0	\$ 5764	\$ 6288	—
120"W Veneer Top — Split	S913WTS4820	255	0.0	\$ 6182	\$ 6744	—

<p>How to specify — Select the Model Number from above.</p> <p>S 9 1 3 </p>	<p>1st Option: FSC Certified Wood (if applicable):</p> <p>FSC Select for FSC Certified Wood (72"W and 96"W only)</p> <p>X No FSC</p>	<p>1st Option: Laminate:</p> <p>See page 493 for finishes.</p>	<p>1st Option: Veneer:</p> <p>See page 493 for finishes.</p>	<p>1st Option: Edge Color (Laminate only):</p> <p>Matching edge color based on laminate selection.</p>	<p>1st Option: Beam and Door Paint Color:</p> <p>P1 P2 P3</p> <p>See page 493 for finishes.</p> <table border="1"> <thead> <tr> <th>Unit Width</th> <th>P2</th> <th>P3</th> </tr> </thead> <tbody> <tr> <td>72"W</td> <td>\$41</td> <td>\$83</td> </tr> <tr> <td>96"W</td> <td>\$46</td> <td>\$101</td> </tr> <tr> <td>120"W</td> <td>\$57</td> <td>\$124</td> </tr> </tbody> </table> <p>P </p>	Unit Width	P2	P3	72"W	\$41	\$83	96"W	\$46	\$101	120"W	\$57	\$124
Unit Width	P2	P3															
72"W	\$41	\$83															
96"W	\$46	\$101															
120"W	\$57	\$124															

Examples: S913LTF4872.X.LM13EY.P7D S913WTS4872.FSC.SC777.P27

- Models below include two end panel bases and connecting hardware. Order matching depth tops that include beams and doors separately on page 497.
- Laminate end panel bases have a flat edge that is color coordinated. Veneer bases have a matching square edge.
- All end panel bases have a 7" W x 1½" D hidden center channel for routing cables from floor to trough.
- Powered end panel bases are power and data ready. Order electrical and data modules and cables separately. See page 499.
- Powered end panel base has cut-out for mounting end panel power/data module and space in the trough for routing cables.
- Non-Powered end panel bases do not have cut-outs.

HARVEST

Description	Model	Ship Weight	Cubes	List Price		
				L1 or V2	L2 or V3	L3
36"D Harvest Classic Table End Panel Bases						
29"H Laminate Base Pair — Non Powered	S913LNB3629	153	12.3	\$ 4365	\$ 4517	\$ 4663
29"H Laminate Base Pair — For Power	S913LPB3629	153	12.3	\$ 4772	\$ 4934	\$ 5100
29"H Veneer Base Pair — Non Powered	S913WNB3629	153	12.3	\$ 5295	\$ 5776	—
29"H Veneer Base Pair — For Power	S913WPB3629	153	12.3	\$ 5707	\$ 6226	—
42"H Laminate Base Pair — Non Powered	S913LNB3642	201	12.3	\$ 4772	\$ 4934	\$ 5100
42"H Laminate Base Pair — For Power	S913LPB3642	201	12.3	\$ 5177	\$ 5352	\$ 5533
42"H Veneer Base Pair — Non Powered	S913WNB3642	201	12.3	\$ 5707	\$ 6226	—
42"H Veneer Base Pair — For Power	S913WPB3642	201	12.3	\$ 6126	\$ 6683	—
42"D Harvest Classic Table End Panel Bases						
29"H Laminate Base Pair — Non Powered	S913LNB4229	172	15.9	\$ 4571	\$ 4728	\$ 4886
29"H Laminate Base Pair — For Power	S913LPB4229	172	15.9	\$ 4975	\$ 5144	\$ 5317
29"H Veneer Base Pair — Non Powered	S913WNB4229	172	15.9	\$ 5047	\$ 5552	—
29"H Veneer Base Pair — For Power	S913WPB4229	172	15.9	\$ 5424	\$ 5967	—
42"H Laminate Base Pair — Non Powered	S913LNB4242	227	15.9	\$ 4975	\$ 5144	\$ 5317
42"H Laminate Base Pair — For Power	S913LPB4242	227	15.9	\$ 5380	\$ 5564	\$ 5749
42"H Veneer Base Pair — Non Powered	S913WNB4242	227	15.9	\$ 5967	\$ 6509	—
42"H Veneer Base Pair — For Power	S913WPB4242	227	15.9	\$ 6383	\$ 6963	—
48"D Harvest Classic Table End Panel Bases						
29"H Laminate Base Pair — Non Powered	S913LNB4829	190	16.2	\$ 4772	\$ 4934	\$ 5100
29"H Laminate Base Pair — For Power	S913LPB4829	190	16.2	\$ 5177	\$ 5352	\$ 5533
29"H Veneer Base Pair — Non Powered	S913WNB4829	190	16.2	\$ 5812	\$ 6340	—
29"H Veneer Base Pair — For Power	S913WPB4829	190	16.2	\$ 6228	\$ 6794	—
42"H Laminate Base Pair — Non Powered	S913LNB4842	254	16.2	\$ 5177	\$ 5352	\$ 5533
42"H Laminate Base Pair — For Power	S913LPB4842	254	16.2	\$ 5582	\$ 5774	\$ 5967
42"H Veneer Base Pair — Non Powered	S913WNB4842	254	16.2	\$ 6383	\$ 6963	—
42"H Veneer Base Pair — For Power	S913WPB4842	254	16.2	\$ 6798	\$ 7416	—

<p>How to specify — Select the Model Number from above.</p> <p>S 9 1 3 </p>	<p>1st Option: FSC Certified Wood (if applicable):</p> <p>FSC Select for FSC Certified Wood X No FSC</p> <p>(NOTE: Laminate is limited to "X" no FSC at this time.)</p>	<p>2nd Option: Laminate (if applicable):</p> <p>See page 493 for finishes.</p>	<p>2nd Option: Veneer (if applicable):</p> <p>See page 493 for finishes.</p>	<p>3rd Option: Edge Color (Laminate only):</p> <p>Matching edge color based on laminate selection.</p>
---	--	---	---	---

Examples: S913LNB3629.X.LM13EY S913WNB3629.FSC.SC777

- Harvest Classic tables offer three power options: Corded, Interlink IQ, or Hardwire.
- Corded models plug directly into an outlet. Corded modules cannot plug into other corded power modules.
- When routing corded models to a wall outlet, the maximum amount of cord that can be exposed outside of the furniture is 6'. (New York, check local code)
- In order to plug corded models into other units the unit would need to be hardwired.
- Interlink IQ modules require a minimum of one Interlink IQ Starter.
- A maximum of 8 Interlink IQ Power Modules (including jumpers) can be “daisy chained” together in any combination off of one 12-amp infeed starter.
- Interlink IQ provides a visual indicator of system status. LED illuminates green when you’re connected and ready to plug in.
- Hardwire models are provided with 20' of sealtight cable.
- In hardwire applications customer must furnish junction boxes, conduit, and additional wire to be in compliance with local and national electrical codes.

Description	Model	Ship Weight	Cubes	List Price	
Corded Power/Data Solutions for Harvest Classic Tables					
6' Corded for Mounting in End Panel Base – 2 Receptacles/1 Data	S913P06CE	<input type="checkbox"/>	6	0.3	\$ 421
12' Corded for Mounting in End Panel Base – 2 Receptacles/1 Data	S913P12CE	<input type="checkbox"/>	8	0.3	\$ 478
20' Corded for Mounting in End Panel Base – 2 Receptacles/1 Data	S913P20CE	<input type="checkbox"/>	11	0.3	\$ 522
6' Corded for Surface Mounting on Harvest Table – 2 Receptacles/1 Data	S913P06CM	<input type="checkbox"/>	6	0.3	\$ 421
12' Corded for Surface Mounting on Harvest Table – 2 Receptacles/1 Data	S913P12CM	<input type="checkbox"/>	8	0.3	\$ 478
20' Corded for Surface Mounting on Harvest Table – 2 Receptacles/1 Data	S913P20CM	<input type="checkbox"/>	11	0.3	\$ 522
Interlink IQ Power/Data Modules for Harvest Classic Tables					
6' Interlink IQ Starter	S913P06LS	<input type="checkbox"/>	8	0.4	\$ 887
10' Interlink IQ Starter	S913P10LS	<input type="checkbox"/>	11	0.4	\$ 931
5' Interlink IQ Jumper	S913P05LJ	<input type="checkbox"/>	8	0.4	\$ 211
Interlink IQ End Panel Base Power Module* w/5' Cord – 2 Receptacles/1 Data	S913PLE	<input type="checkbox"/>	8	0.4	\$ 530
Interlink IQ Surface Mounted Power Module* w/5' Cord – 2 Receptacles/1 Data	S913PLM	<input type="checkbox"/>	8	0.4	\$ 530
Interlink IQ Hidden Power Module* w/5' Cord – 2 Receptacles	S913PLHE	<input type="checkbox"/>	8	0.4	\$ 487
Interlink IQ Hidden Power Module* w/5' Cord – 1 Receptacle/1 Data	S913PLHED	<input type="checkbox"/>	8	0.4	\$ 487
* Interlink IQ Power Modules require a minimum of one Interlink IQ Starter within configuration.					
Hardwire Power/Data Solutions for Harvest Classic Tables					
20' Hard Wire for Mounting in End Panel Base – 2 Receptacles/1 Data	S913P20HE	<input type="checkbox"/>	14	0.4	\$ 745
20' Hard Wire for Surface Mounting on Harvest Table – 2 Receptacles/1 Data	S913P20HM	<input type="checkbox"/>	14	0.4	\$ 745

Shippable by small-package carrier.

How to specify —
Select the Model Number from above.

S | 9 | 1 | 3 | | | | | | | | | | | | | | | | | | | | | |

Examples: S913P06CE S913P06LS S913P20HE

The Harvest Rustic table is designed to help you feel at ease hosting gatherings of all kinds. Seated- and standing-height tables are perfect for everything from the brainstorm to the weekly donut club. All the necessities of the office mixed with an appealing, familiar aesthetic. Bring your team together around the Harvest Rustic table.

MODELS AND OPTIONS

Harvest Rustic offers three wood finish options for the legs to mix and match a wide selection of laminate top finishes or select a rustic plank top in matching finish. Perfect for cafés, atriums, open-plan areas, and collaboration spaces.

Choose between seated- and standing-height tables, square and rectangular shapes. Standing-height tables have a footrest for added comfort.

Harvest Rustic powered tables include built-in power and USB capabilities to power equipment.

POWERED TABLES

Each table includes six simplex electrical outlets and six double USB ports (illustrated below) that are recessed at 6 locations within the 12" D x 3" H cubbies located just below table top on the two longest sides. Cubby area provides ample room for power supplies, excess cord, phone, and other paper, binders, or supplies — keeping the table top clear for the work at hand.

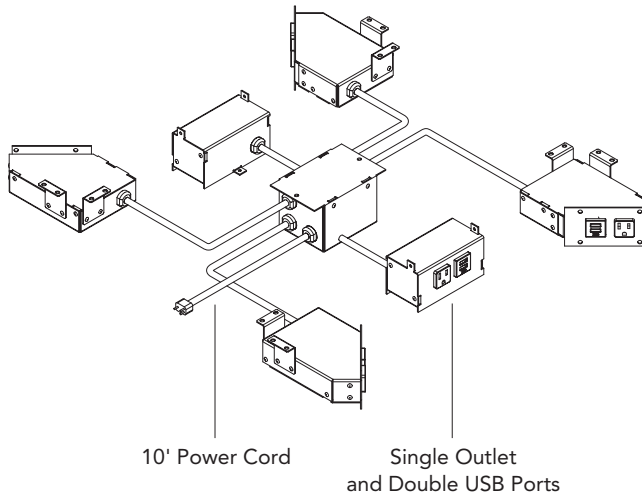

NON-POWERED TABLES

Non-powered models feature a wooden apron on all four sides of the table (no cubbies). Without cubbies, non-powered tables cannot be easily converted to powered tables.

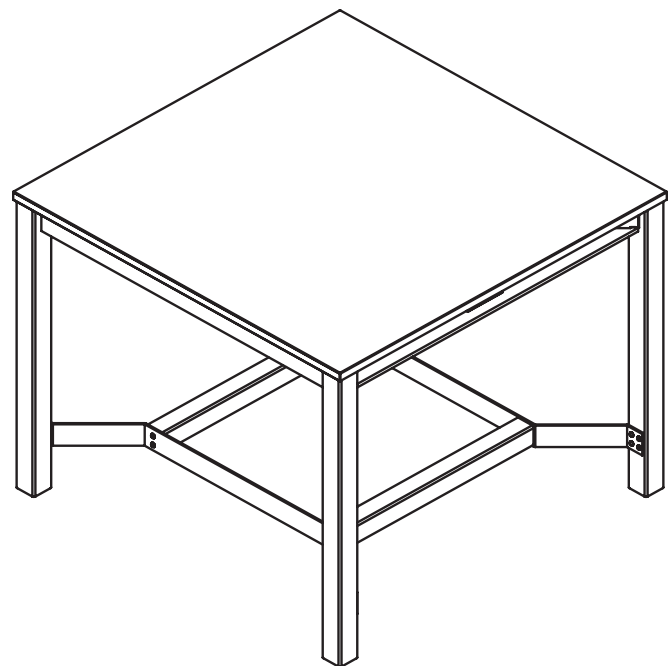
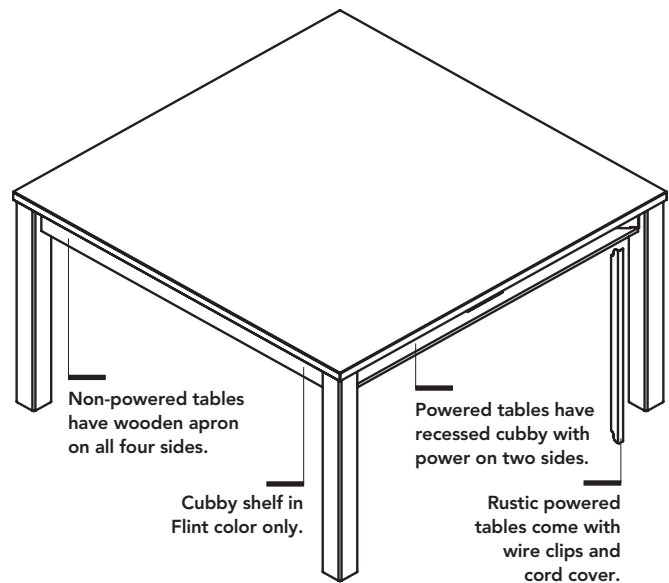

The beauty of wood is the natural variation of grain patterns and colors that make each piece unique. This variation is also influenced by lighting conditions, orientation of mated parts, and varying acceptance of the finishing process. The varying colors and physical characteristics naturally occur in all wood species but are most pronounced in lighter colored woods, and are especially evident in natural finishes.

Note: Harvest Rustic Plank worksurfaces will have natural markings and imperfections. Please contact Customer Support for additional information.

GSA SIN 33721

- Table comes complete with laminate or plank top with flat edges, solid wood legs — 29"H seated or 42"H standing height, painted metal support structure, and electrical — assembly required.
- Each powered table includes 6 simplex electrical outlets and 6 double USB ports recessed within the 12"D x 3"H cubbies located just below table top on the two longest sides. See page 500.
- See page 502 for non-powered tables.
- Cubby shelf color is not specified and comes in Flint.
- Electrical is corded with plug; for hardwired add "HW" suffix and \$181 upcharge. Cord to power is 10' long from center of table top.
- Rustic powered tables come with wire clips and painted metal wire management cover for routing cable down table leg. Cover attaches with double faced tape.

Description	Model Number Add "L" for Laminate or "P" for Plank	Ship Weight	Cubes	Laminate List Price			List Price Plank Top
				L1	L2	L3	
36"D Harvest Rustic — includes top, legs, metal under supports, and electrical							
72"W x 29"H	S942 □ TSE3672	209	19	\$ 6073	\$ 6104	\$ 6131	\$ 11598
84"W x 29"H	S942 □ TSE3684	259	24	\$ 6580	\$ 6617	\$ 6652	\$ 12689
96"W x 29"H	S942 □ TSE3696	277	27	\$ 6905	\$ 6949	\$ 6992	\$ 13698
120"W x 29"H	S942 □ TSE36120	305	29	\$ 7049	\$ 7099	\$ 7151	\$ 14250
72"W x 42"H	S942 □ TST3672	240	30	\$ 7375	\$ 7406	\$ 7433	\$ 12900
84"W x 42"H	S942 □ TST3684	293	36	\$ 7918	\$ 7955	\$ 7990	\$ 14027
96"W x 42"H	S942 □ TST3696	313	40	\$ 8319	\$ 8363	\$ 8406	\$ 15112
120"W x 42"H	S942 □ TST36120	343	44	\$ 8729	\$ 8779	\$ 8831	\$ 15930
42"D Harvest Rustic — includes top, legs, metal under supports, and electrical							
72"W x 29"H	S942 □ TSE4272	223	21	\$ 6853	\$ 6890	\$ 6925	\$ 12093
84"W x 29"H	S942 □ TSE4284	277	26	\$ 7281	\$ 7324	\$ 7365	\$ 13340
96"W x 29"H	S942 □ TSE4296	299	29	\$ 7604	\$ 7653	\$ 7703	\$ 14214
120"W x 29"H	S942 □ TSE42120	328	31	\$ 7751	\$ 7807	\$ 7867	\$ 14949
72"W x 42"H	S942 □ TST4272	270	32	\$ 8482	\$ 8519	\$ 8554	\$ 13722
84"W x 42"H	S942 □ TST4284	327	38	\$ 8946	\$ 8989	\$ 9030	\$ 15005
96"W x 42"H	S942 □ TST4296	351	42	\$ 9345	\$ 9394	\$ 9444	\$ 15955
120"W x 42"H	S942 □ TST42120	382	46	\$ 9758	\$ 9814	\$ 9874	\$ 16956
48"D Harvest Rustic — includes top, legs, metal under supports, and electrical							
72"W x 29"H	S942 □ TSE4872	237	22	\$ 7591	\$ 7634	\$ 7675	\$ 12869
84"W x 29"H	S942 □ TSE4884	296	28	\$ 8088	\$ 8136	\$ 8184	\$ 13786
96"W x 29"H	S942 □ TSE4896	322	31	\$ 8238	\$ 8293	\$ 8351	\$ 14521
120"W x 29"H	S942 □ TSE48120	350	33	\$ 8545	\$ 8607	\$ 8673	\$ 15723
72"W x 42"H	S942 □ TST4872	285	34	\$ 9473	\$ 9516	\$ 9557	\$ 14751
84"W x 42"H	S942 □ TST4884	347	40	\$ 10006	\$ 10054	\$ 10102	\$ 15704
96"W x 42"H	S942 □ TST4896	375	45	\$ 10232	\$ 10287	\$ 10345	\$ 16515
120"W x 42"H	S942 □ TST48120	405	49	\$ 10805	\$ 10867	\$ 10933	\$ 17983
Square Harvest Rustic — includes top, legs, metal under supports, and electrical							
54" Square x 29"H	S942 □ TSE545QR	214	19	\$ 5774	\$ 5811	\$ 5846	\$ 11778
60" Square x 29"H	S942 □ TSE605QR	241	22	\$ 6174	\$ 6218	\$ 6261	\$ 12968
54" Square x 42"H	S942 □ TST545QR	242	30	\$ 7008	\$ 7045	\$ 7080	\$ 13012
60" Square x 42"H	S942 □ TST605QR	273	34	\$ 7556	\$ 7600	\$ 7643	\$ 14350

Note: Add suffix "HW" to model number for Hardwire, \$181 upcharge. *Example: S943LTSE3672HW*

<p>How to specify —</p> <p>Select the Model Number from above.</p>	<p>1st Option:</p> <p>FSC Certified Wood:</p> <p>X No FSC</p>	<p>2nd Option:</p> <p>Laminate:</p> <p>See page 493 for Harvest Rustic finishes.</p>	<p>3rd Option:</p> <p>Edge Color:</p> <p>See page 493 for Harvest Rustic finishes.</p>	<p>4th Option:</p> <p>Harvest Rustic Wood Leg Color:</p> <p>LL814 Medium Grey LL815 Light Neutral LL897 Dark Brown</p>	<p>4th Option:</p> <p>Paint Color for Metal Under Supports and Wire Cover:</p> <p>P1 P2 P3</p> <p>See page 493 for paint colors and codes. P2 upcharge: \$37 on 29"H, \$109 on 42"H</p>
<p>S 9 4 2 . X L L 8</p>					

Examples: S942LTSE3672.X.LPE1.PE.LL814.P02 S942PTSE3672.X.LL814.P02

HARVEST

- Table comes complete with laminate top with flat edges, solid wood legs — 29"H seated or 42"H standing height, and painted metal support structure — assembly required.
- Non-powered tables feature a wooden apron on all four sides and cannot be easily converted to powered tables.
- See page 501 for powered tables.

HARVEST

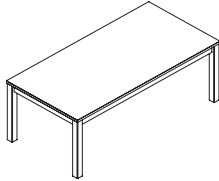

Seated Height

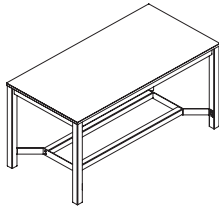

Standing Height

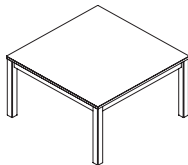

Seated Height

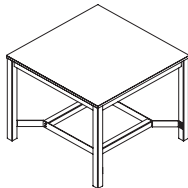

Standing Height

Description	Model Number Add "L" for Laminate or "P" for Plank	Ship Weight	Cubes	Laminate List Price			List Price Plank Top
				L1	L2	L3	
36"D Harvest Rustic Non-Powered — includes top, legs, and metal under supports							
72"W x 29"H	S942 <input type="checkbox"/> TSE3672NP	209	19	\$ 5178	\$ 5209	\$ 5236	\$ 10703
84"W x 29"H	S942 <input type="checkbox"/> TSE3684NP	259	24	\$ 5685	\$ 5722	\$ 5757	\$ 11794
96"W x 29"H **	S942 <input type="checkbox"/> TSE3696NP	277	27	\$ 6008	\$ 6052	\$ 6095	\$ 12801
120"W x 29"H **	S942 <input type="checkbox"/> TSE36120NP	305	29	\$ 6153	\$ 6203	\$ 6255	\$ 13354
72"W x 42"H	S942 <input type="checkbox"/> TST3672NP	240	30	\$ 6484	\$ 6515	\$ 6542	\$ 12009
84"W x 42"H	S942 <input type="checkbox"/> TST3684NP	293	36	\$ 7027	\$ 7064	\$ 7099	\$ 13136
96"W x 42"H **	S942 <input type="checkbox"/> TST3696NP	313	40	\$ 7426	\$ 7470	\$ 7513	\$ 14219
120"W x 42"H **	S942 <input type="checkbox"/> TST36120NP	343	44	\$ 7837	\$ 7887	\$ 7939	\$ 15038
42"D Harvest Rustic Non-Powered — includes top, legs, and metal under supports							
72"W x 29"H	S942 <input type="checkbox"/> TSE4272NP	223	21	\$ 5958	\$ 5995	\$ 6030	\$ 11198
84"W x 29"H	S942 <input type="checkbox"/> TSE4284NP	277	26	\$ 6386	\$ 6429	\$ 6470	\$ 12445
96"W x 29"H	S942 <input type="checkbox"/> TSE4296NP	299	29	\$ 6707	\$ 6756	\$ 6806	\$ 13317
120"W x 29"H	S942 <input type="checkbox"/> TSE42120NP	328	31	\$ 6855	\$ 6911	\$ 6971	\$ 14053
72"W x 42"H	S942 <input type="checkbox"/> TST4272NP	270	32	\$ 7594	\$ 7631	\$ 7666	\$ 12834
84"W x 42"H	S942 <input type="checkbox"/> TST4284NP	327	38	\$ 8058	\$ 8101	\$ 8142	\$ 14117
96"W x 42"H	S942 <input type="checkbox"/> TST4296NP	351	42	\$ 8455	\$ 8504	\$ 8554	\$ 15065
120"W x 42"H	S942 <input type="checkbox"/> TST42120NP	382	46	\$ 8869	\$ 8925	\$ 8985	\$ 16067
48"D Harvest Rustic Non-Powered — includes top, legs, and metal under supports							
72"W x 29"H	S942 <input type="checkbox"/> TSE4872NP	237	22	\$ 6696	\$ 6739	\$ 6780	\$ 11974
84"W x 29"H	S942 <input type="checkbox"/> TSE4884NP	296	28	\$ 7193	\$ 7241	\$ 7289	\$ 12891
96"W x 29"H	S942 <input type="checkbox"/> TSE4896NP	322	31	\$ 7341	\$ 7396	\$ 7454	\$ 13624
120"W x 29"H	S942 <input type="checkbox"/> TSE48120NP	350	33	\$ 7649	\$ 7711	\$ 7777	\$ 14827
72"W x 42"H	S942 <input type="checkbox"/> TST4872NP	285	34	\$ 8582	\$ 8625	\$ 8666	\$ 13860
84"W x 42"H	S942 <input type="checkbox"/> TST4884NP	347	40	\$ 9115	\$ 9163	\$ 9211	\$ 14813
96"W x 42"H	S942 <input type="checkbox"/> TST4896NP	375	45	\$ 9339	\$ 9394	\$ 9452	\$ 15622
120"W x 42"H	S942 <input type="checkbox"/> TST48120NP	405	49	\$ 9913	\$ 9975	\$ 10041	\$ 17091
Square Harvest Rustic Non-Powered — includes top, legs, and metal under supports							
54" Square x 29"H	S942 <input type="checkbox"/> TSE54SQRNP	214	19	\$ 4662	\$ 4699	\$ 4734	\$ 10666
60" Square x 29"H	S942 <input type="checkbox"/> TSE60SQRNP	241	22	\$ 4978	\$ 5022	\$ 5065	\$ 11772
54" Square x 42"H	S942 <input type="checkbox"/> TST54SQRNP	242	30	\$ 5901	\$ 5938	\$ 5973	\$ 11905
60" Square x 42"H	S942 <input type="checkbox"/> TST60SQRNP	273	34	\$ 6360	\$ 6404	\$ 6447	\$ 13154

How to specify —
Select the
Model Number
from above.

1st Option:
FSC Certified
Wood:
X No FSC

2nd Option:
Laminate:
See page 493 for
Harvest Rustic
laminate finishes.

3rd Option:
Edge Color:
See page 493 for
Harvest Rustic
edge finishes.

4th Option:
Harvest Rustic
Wood Leg Color:
LL814 Medium
Grey
LL815 Light
Neutral
LL897 Dark Brown

4th Option:
Paint Color for Metal
Under Supports:
P1 P2 P3
See page 493 for paint
colors and codes. P2
upcharge: \$37 on 29"H,
\$109 on 42"H

S | 9 | 4 | 2 | | | | | | | | | | . | X | | | | | | | | . | | | | | . | | | | | | | | . | L | L | 8 | | | | | | | | . | | | | | | | | | |

Examples: S942LTSE3672NP.X.LPE1.PE.LL814.P02 S942PTSE3672NP.X.LL814.PR6

The Harvest Metal table is designed to help you feel at ease hosting gatherings of all kinds. Seated- and standing-height tables are perfect for everything from the brainstorm to the weekly robotics club. All the necessities of the office mixed with an appealing, familiar aesthetic. Bring your team together around the Harvest Metal table.

MODELS AND OPTIONS

Harvest Metal offers numerous painted options for the metal legs to mix and match a wide selection of laminate and veneer top finishes. Perfect for cafés, atriums, open-plan areas, and collaboration spaces.

Choose between seated- and standing-height tables, square and rectangular shapes. Standing-height table has a footrest for added comfort.

Harvest Metal powered tables include built-in power and USB capabilities to power equipment.

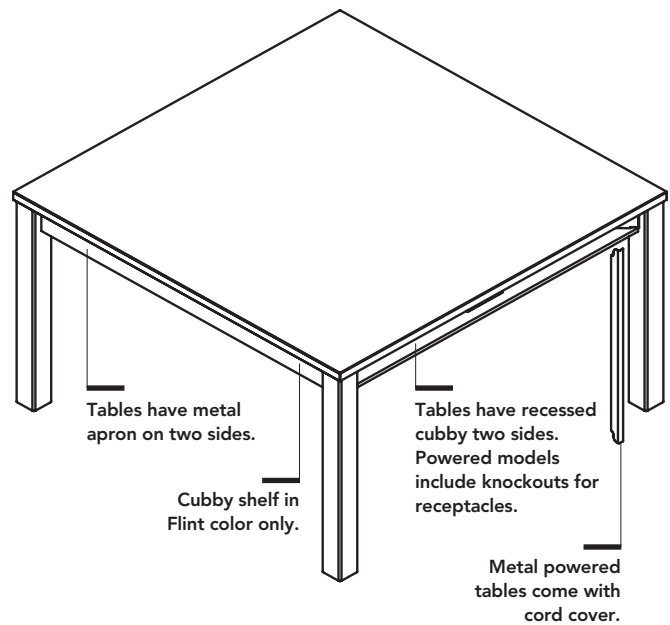

POWERED TABLES

Each table includes six simplex electrical outlets and six double USB ports (illustrated below) that are recessed at 6 locations within the 12"D x 3"H cubbies located just below table top on the two longest sides. Cubby area provides ample room for power supplies, excess cord, phone, and other paper, binders, or supplies — keeping the table top clear for the work at hand.

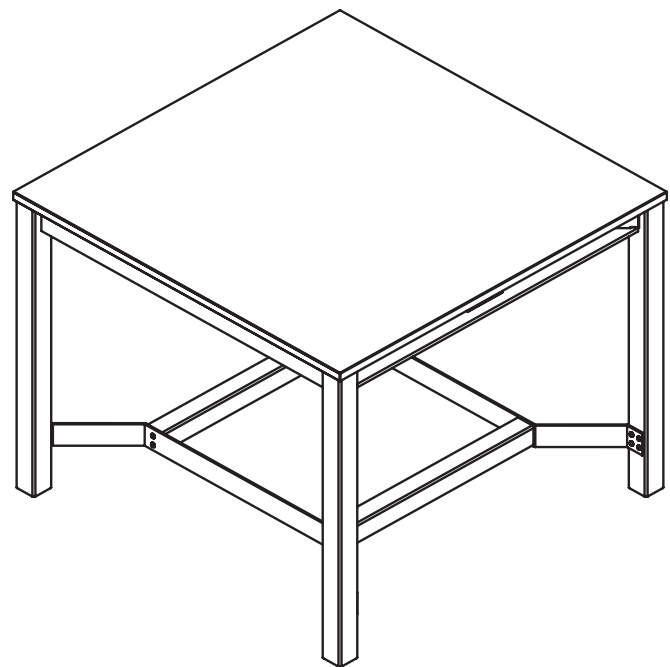
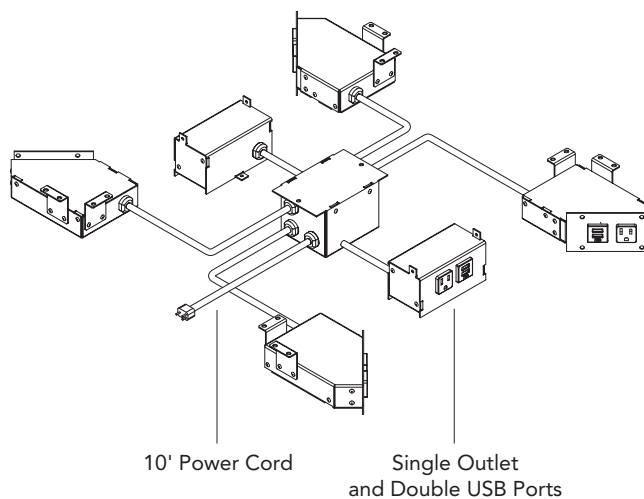

NON-POWERED TABLES

Non-powered metal models feature cubbies, but without any knock-outs for receptacles. Non-powered tables cannot be easily converted to powered tables.

- Table comes complete with laminate or veneer top, painted metal legs — 29"H seated or 42"H standing height, support structure, and electrical — assembly required.
- Each powered table includes 6 simplex electrical outlets and 6 double USB ports recessed within the 12"D x 3"H cubbies located just below table top on the two longest sides. See page 503.
- See page 505 for non-powered tables.
- Cubby shelf color is not specified and comes in Flint.
- Electrical is corded with plug; for hardwired add "HW" suffix and \$181 upcharge. Cord to power is 10' long from center of table top.
- Tables come with painted metal wire management cover for routing cable down table leg. Cover attaches with double faced tape.

HARVEST

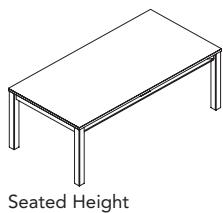

Description	Model Number add "L" for Laminate or "V" for Veneer	Ship Weight	Cubes	Laminate List Price			Veneer List Price	
				L1	L2	L3	V2	V3
36"D Harvest Metal — includes top, legs, metal under supports, and electrical.								
72"W x 29"H	S943 □ TSE3672	209	19	\$ 5954	\$ 5985	\$ 6012	\$ 9906	\$10806
84"W x 29"H	S943 □ TSE3684	259	24	\$ 6461	\$ 6498	\$ 6533	\$10852	\$11838
96"W x 29"H	S943 □ TSE3696	277	27	\$ 6786	\$ 6830	\$ 6873	\$11673	\$12734
120"W x 29"H	S943 □ TSE36120	305	29	\$ 6930	\$ 6980	\$ 7032	\$12117	\$13218
72"W x 42"H	S943 □ TST3672	240	30	\$ 7227	\$ 7258	\$ 7285	\$11306	\$12334
84"W x 42"H	S943 □ TST3684	293	36	\$ 7763	\$ 7800	\$ 7835	\$12284	\$13401
96"W x 42"H	S943 □ TST3696	313	40	\$ 8158	\$ 8202	\$ 8245	\$13182	\$14380
120"W x 42"H	S943 □ TST36120	343	44	\$ 8560	\$ 8610	\$ 8662	\$13910	\$15174

42"D Harvest Metal — includes top, legs, metal under supports, and electrical.								
72"W x 29"H	S943 □ TSE4272	223	21	\$ 6726	\$ 6763	\$ 6798	\$10128	\$11049
84"W x 29"H	S943 □ TSE4284	277	26	\$ 7154	\$ 7197	\$ 7238	\$11085	\$12093
96"W x 29"H	S943 □ TSE4296	299	29	\$ 7477	\$ 7526	\$ 7576	\$11801	\$12874
120"W x 29"H	S943 □ TSE42120	328	31	\$ 7624	\$ 7680	\$ 7740	\$12386	\$13512
72"W x 42"H	S943 □ TST4272	270	32	\$ 8322	\$ 8359	\$ 8394	\$11884	\$12964
84"W x 42"H	S943 □ TST4284	327	38	\$ 8779	\$ 8822	\$ 8863	\$12873	\$14043
96"W x 42"H	S943 □ TST4296	351	42	\$ 9172	\$ 9221	\$ 9271	\$13666	\$14908
120"W x 42"H	S943 □ TST42120	382	46	\$ 9577	\$ 9633	\$ 9693	\$14535	\$15856

48"D Harvest Metal — includes top, legs, metal under supports, and electrical.								
72"W x 29"H	S943 □ TSE4872	237	22	\$ 7443	\$ 7486	\$ 7527	\$10793	\$11774
84"W x 29"H	S943 □ TSE4884	296	28	\$ 7940	\$ 7988	\$ 8036	\$11653	\$12712
96"W x 29"H	S943 □ TSE4896	322	31	\$ 8090	\$ 8145	\$ 8203	\$12093	\$13192
120"W x 29"H	S943 □ TSE48120	350	33	\$ 8397	\$ 8459	\$ 8525	\$13057	\$14244
72"W x 42"H	S943 □ TST4872	385	34	\$ 9287	\$ 9330	\$ 9371	\$12821	\$13986
84"W x 42"H	S943 □ TST4884	347	40	\$ 9813	\$ 9861	\$ 9909	\$13584	\$14819
96"W x 42"H	S943 □ TST4896	375	45	\$10033	\$10088	\$10146	\$14230	\$15524
120"W x 42"H	S943 □ TST48120	405	49	\$10598	\$10660	\$10726	\$15479	\$16886

Square Harvest Metal — includes top, legs, metal under supports, and electrical.								
54" Square x 29"H**	S943 □ TSE54SQR	214	19	\$ 5655	\$ 5692	\$ 5727	\$10162	\$11086
60" Square x 29"H**	S943 □ TSE60SQR	241	22	\$ 6055	\$ 6099	\$ 6142	\$11191	\$12208
54" Square x 42"H**	S943 □ TST54SQR	242	30	\$ 6865	\$ 6902	\$ 6937	\$11493	\$12538
60" Square x 42"H**	S943 □ TST60SQR	273	34	\$ 7398	\$ 7442	\$ 7485	\$12668	\$13820

** 54" and 60" square veneer tops ship in two pieces.

Note: Add suffix "HW" to model number for Hardwire, \$181 upcharge. *Example:* S943LTST3672HW

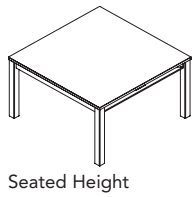

How to specify — Select the Model Number from above.	1st Option: FSC Certified Wood: X No FSC	2nd Option: Veneer Finish (Veneer only): FF Full Finish OP Open pore	3rd Option: Laminate or Veneer: See page 493 for Harvest Metal finishes.	4th Option: Edge Color (Laminate only): See page 493 for Harvest Metal finishes.	5th Option: Paint Color for Metal Legs, Supports, and Wire Cover: P1 P2 P3 See page 493 for P1 and Select paint colors and codes. P2 upcharge: \$37 on 29"H, \$109 on 42"H
S 9 4 3	. X

Example: S943LTSE3672.X.LPE1.PE.P02 S943LTSE3672.X.FF.SC777.P02

- Table comes complete with laminate or veneer top, painted metal legs — 29"H seated or 42"H standing height, and support structure — assembly required.
- See page 504 for powered tables.
- Non-powered tables feature a metal apron on the two depth sides and cubby storage on the two width sides. Cubbies on non-powered tables do not have electrical or data ports and therefore cannot be easily converted to powered tables.
- Cubby shelf color is not specified and comes in Flint.

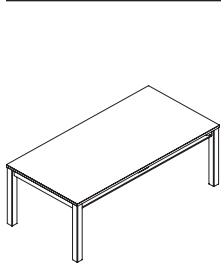

Seated Height

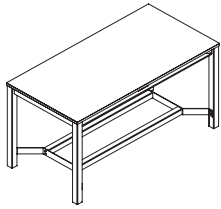

Standing Height

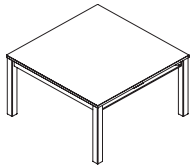

Seated Height

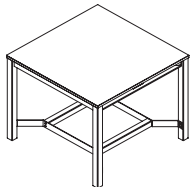

Standing Height

Description	Model Number add "L" for Laminate or "V" for Veneer	Ship Weight	Cubes	Laminate List Price			Veneer List Price	
				L1	L2	L3	V2	V3
36"D Harvest Metal Non-Powered — includes top, legs, and metal under supports.								
72"W x 29"H	S943 □ TSE3672NP	209	19	\$ 5136	\$ 5167	\$ 5194	\$ 9171	\$10005
84"W x 29"H	S943 □ TSE3684NP	259	24	\$ 5643	\$ 5680	\$ 5715	\$10117	\$11037
96"W x 29"H	S943 □ TSE3696NP	277	27	\$ 5968	\$ 6012	\$ 6055	\$10938	\$11932
120"W x 29"H	S943 □ TSE36120NP	305	29	\$ 6112	\$ 6162	\$ 6214	\$11382	\$12417
72"W x 42"H	S943 □ TST3672NP	209	19	\$ 6339	\$ 6370	\$ 6397	\$10494	\$11448
84"W x 42"H	S943 □ TST3684NP	259	24	\$ 6875	\$ 6912	\$ 6947	\$11472	\$12515
96"W x 42"H	S943 □ TST3696NP	277	27	\$ 7270	\$ 7314	\$ 7357	\$12370	\$13494
120"W x 42"H	S943 □ TST36120NP	305	29	\$ 7672	\$ 7722	\$ 7774	\$13098	\$14289

42"D Harvest Metal Non-Powered — includes top, legs, and metal under supports.								
72"W x 29"H	S943 □ TSE4272NP	209	19	\$ 5908	\$ 5945	\$ 5980	\$ 9680	\$10560
84"W x 29"H	S943 □ TSE4284NP	259	24	\$ 6336	\$ 6379	\$ 6420	\$10730	\$11705
96"W x 29"H	S943 □ TSE4296NP	277	27	\$ 6659	\$ 6708	\$ 6758	\$11446	\$12486
120"W x 29"H	S943 □ TSE42120NP	305	29	\$ 6806	\$ 6862	\$ 6922	\$12031	\$13125
72"W x 42"H	S943 □ TST4272NP	209	19	\$ 7431	\$ 7468	\$ 7503	\$11356	\$12388
84"W x 42"H	S943 □ TST4284NP	259	24	\$ 7888	\$ 7931	\$ 7972	\$12437	\$13568
96"W x 42"H	S943 □ TST4296NP	277	27	\$ 8281	\$ 8330	\$ 8380	\$13230	\$14433
120"W x 42"H	S943 □ TST42120NP	305	29	\$ 8686	\$ 8742	\$ 8802	\$14099	\$15381

48"D Harvest Metal Non-Powered — includes top, legs, and metal under supports.								
72"W x 29"H	S943 □ TSE4872NP	209	19	\$ 6625	\$ 6668	\$ 6709	\$10345	\$11285
84"W x 29"H	S943 □ TSE4884NP	259	24	\$ 7122	\$ 7170	\$ 7218	\$11169	\$12184
96"W x 29"H	S943 □ TSE4896NP	277	27	\$ 7272	\$ 7327	\$ 7385	\$11737	\$12804
120"W x 29"H	S943 □ TSE48120NP	305	29	\$ 7579	\$ 7641	\$ 7707	\$12702	\$13857
72"W x 42"H	S943 □ TST4872NP	209	19	\$ 8396	\$ 8439	\$ 8480	\$12293	\$13410
84"W x 42"H	S943 □ TST4884NP	259	24	\$ 8922	\$ 8970	\$ 9018	\$13149	\$14344
96"W x 42"H	S943 □ TST4896NP	277	27	\$ 9142	\$ 9197	\$ 9255	\$13794	\$15048
120"W x 42"H	S943 □ TST48120NP	305	29	\$ 9707	\$ 9769	\$ 9835	\$15043	\$16410

Square Harvest Metal Non-Powered — includes top, legs, and metal under supports.								
54" Square x 29"H**	S943 □ TSE54SQRNP	209	19	\$ 4837	\$ 4874	\$ 4909	\$ 9262	\$10104
60" Square x 29"H**	S943 □ TSE60SQRNP	259	24	\$ 5237	\$ 5281	\$ 5324	\$10291	\$11226
54" Square x 42"H**	S943 □ TST54SQRNP	209	19	\$ 5975	\$ 6012	\$ 6047	\$10514	\$11470
60" Square x 42"H**	S943 □ TST60SQRNP	259	24	\$ 6510	\$ 6554	\$ 6597	\$11691	\$12754

** 54" and 60" square veneer tops ship in two pieces.

<p>How to specify — Select the Model Number from above.</p> <p>S 9 4 3 </p>	<p>1st Option: FSC Certified Wood: X No FSC</p>	<p>2nd Option: Veneer Finish (Veneer only): FF Full Finish OP Open pore</p>	<p>3rd Option: Laminate or Veneer: See page 493 for Harvest Metal finishes.</p>	<p>4th Option: Edge Color (Laminate only): See page 493 for Harvest Metal finishes.</p>	<p>5th Option: Paint Color for Metal Legs and Under Supports: P1 P2 P3 See page 493 for P1 and P2 paint colors and codes. P2 upcharge: \$37 on 29"H, \$109 on 42"H</p>
	<p>Example: S943LTSE3672NP.X.LPE1.PE.P02 S943LTSE3672NP.X.FF.SC777.P02</p>				

Structure rounds out the Allsteel table offering and supports a wide array of applications, from conference rooms to café settings and everything in between.

The tables are adaptable and interchangeable for use in multiple spaces. The combination of rich details and durable design creates an experience out of any activity at the office while elevating culture and brand. A variety of table top shapes, edges, bases, and finishes ensures a consistent aesthetic throughout the entire floorplan.

MODELS AND OPTIONS

Structure is available in five heights and ten top shapes.

APPLICATION

Use in open meeting areas, dedicated collaboration rooms, neighborhood spaces, cafés, large and smaller conference rooms, libraries, and lounge areas.

KEY FEATURES

Range of shapes, sizes, and configurations to meet the needs of any space available in an array of materials.

MATERIALS AND EDGE TREATMENTS

Woodgrain laminates will be aligned within 3/8" across seams unless otherwise noted in the price guide pages.

Laminate Edges

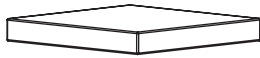

Flat Edge

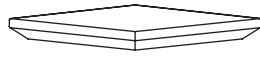

Knife Edge

SINGLE-PIECE TOPS

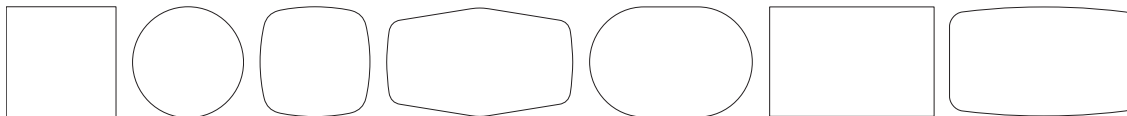

Size Ranges

Square
24"-84"

Round
24"-84"

Soft Square
24"-84"

Diamond
24"-54"W
40"-96"L

Racetrack
24"-54"W
36"-96"L

Rectangle
24"-54"W
36"-96"L

Boat
30", 36"W
52", 60", 72"L

TWO-PIECE TOPS

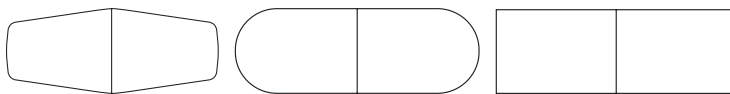

Size Ranges

Diamond
48"-60"W
120"-192"L

Racetrack
42"-60"W
120"-168"L

Rectangle
36"-60"W
120"-168"L

MEDIA TOPS

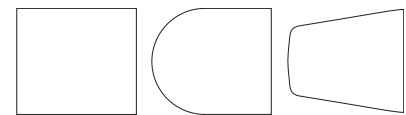

Rectangle

Racetrack
48", 54" or 60"W
54", 60" or 72"L

Diamond

THREE-PIECE TOPS



Size Ranges

Racetrack
54"-60"W
192"-240"L

Rectangle
54"-60"W
192"-240"L

GRAIN DIRECTION AND ALIGNMENT

SINGLE-PIECE TOPS – Woodgrain laminates as standard product are always oriented with the grain direction running parallel to the length of the table top.

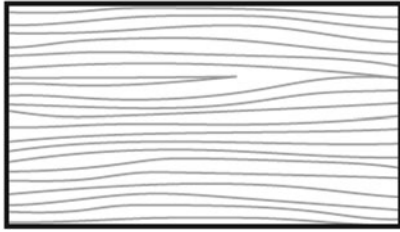

TWO & THREE PIECE TOPS – Tops longer than 96". Woodgrain laminates as standard product are always oriented with the grain direction running parallel to the length of the tabletop. Please note that 2-piece tops, in woodgrain colors, will not have exact grain alignment in the center where the two halves meet, a reasonable match can be expected. Allsteel cannot guarantee a grain match on tables that are 60"W.

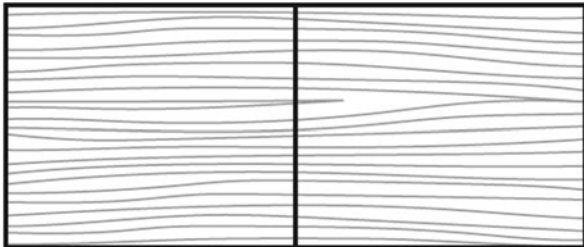

SPECIAL TOPS – Specials for wide tables. Woodgrain laminates as specials wider than 60" are always oriented with the grain direction running parallel to the seam of the tabletop. Allsteel will create best match grain alignment but cannot guarantee a perfect match along the seam between the pieces of laminate on two and three piece tops.

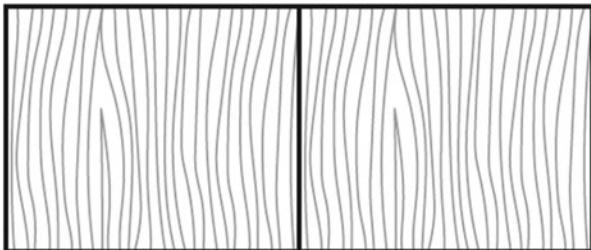

PAINT FINISHES

GRADE P1	
Black	P71
Brownstone	P7D
Bungalow	P7C
Charblack	CBK
Cinder	P7Q
Cove	P096
Designer White	PJW
Designer White Texture	PK7
Dune	P094
Flint	P02
Fossil	P28
Harbor	P097
Loft	P7B
Muslin	P4J
Pebble	P8R
Pewter	P8D
Sage	P095
Salt	P8C
Textured Brownstone	P7J
Textured Flint	P7A
Textured Loft	P7L
Textured Muslin	P7M
Textured Pebble	P8Y
Textured Salt	P8Z
Textured Titanium	P8V
Titanium	P8T
GRADE P2	
Champagne Metallic	PR5
Designer White 65 High Gloss	P8W
Gunmetal Metallic	PR3
Night Bronze	P8B
Platinum Metallic	PR2
Pyrite	PJE
Silver	PR6
Silver Texture	PR8
Solar Black	P8X
GRADE P3	
Atom	P8S
Blossom***	P8K
Bullseye	PJF
Cabernet***	P7T
Conifer***	P8H
Ember	P8P
Ion	P8N
Iris	P8J
Krypton	P8F
Regatta	P8M
Succulent***	P8A

***These colors are intended to be an inspirational option for the trending market. Product application is limited and color availability is approximately two years to coincide with evolving workplace trends.

PEDESTAL BASE PAINT FINISHES

GRADE P1	
Charblack	CBK
Textured Designer White	PK7
Textured Brownstone	P7J
Textured Flint	P7A
Textured Loft	P7L
Textured Muslin	P7M
Textured Pebble	P8Y
Textured Salt	P8Z
Textured Titanium	P8V
GRADE P2	
Silver Texture	PR8

LAMINATES

GRADE L1	
SOLID	
Black	P
Brownstone	LM13
Bungalow	LM12
Designer White 15051	LDW1
Flint	LM16
Fossil Shale	LEH1
Loft	LM11
Muslin	LM15
Titanium	LTI1
ABSTRACT	
Ash	LT3B
Handspun Pearl	LAHP
Handspun Dove	LAHD
Handspun Slate	LAHS
Handspun Chestnut	LAHC
Silver Mesh	LT8D
WOODGRAIN	
Belair	LWBA
Bourbon Cherry	H
Field Elm	LWFE
Florence Walnut	LFW1
Kingswood Walnut	LK11
Natural Maple	LWD
Neo Walnut	LNU1
Pinnacle	PINC
Shaker Cherry	LW7C
GRADE L2	
WOODGRAIN	
Beigewood	LWBE
Fawn Cypress	LFC1
Lowell Ash	LLA1
Mangalore Mango	LMM1
Natural Recon	LNR1
Phantom Charcoal	LPC1
Phantom Ecru	LPE1
Portico Teak	LPT1
Skyline Walnut	LSW1
Veranda Teak	LVT1
GRADE L3	
Natural Walnut	LWNW

LAMINATE EDGE COLORS

Beigewood	DE
Belair	BA
Black	E4
Bourbon Cherry	H
Brownstone	EY
Bungalow	EX
Designer White	DW
Fawn Cypress	FC
Field Elm	FE
Flint	E9
Florence Walnut	FW
Fossil	EH
Kingswood Walnut	KI
Loft	EV
Lowell Ash	DL
Mangalore Mango	MM
Muslin	EU
Natural Maple	DD
Natural Recon	NR
Natural Walnut	DN
Neo Walnut	NU
Parchment	EN
Phantom Charcoal	PC
Phantom Ecru	PE
Pinnacle	PI
Platinum Metallic	EP
Plyband	PL
Portico Teak	DP
Shaker Cherry	DF
Skyline Walnut	SW
Titanium	TI
Veranda Teak	VT

LAMINATE BASE FINISHES

L1 – SOLID	
Black	P
Designer White	LDW1
Flint	LM16
Loft	LM11
L1 – WOODGRAIN	
Bourbon Cherry	H
Field Elm	LWFE
Florence Walnut	LFW1
Kingswood Walnut	LK11
Natural Maple	LWD
Neo Walnut	LNU1
Pinnacle	PINC
Shaker Cherry	LW7C
L2 – WOODGRAIN	
Beigewood	LWBE
Fawn Cypress	LFC1
Lowell Ash	LLA1
Mangalore Mango	LMM1
Natural Recon	LNR1
Phantom Charcoal	LPC1
Phantom Ecru	LPE1
Portico Teak	LPT1
Skyline Walnut	LSW1
Veranda Teak	LVT1
L3 – WOODGRAIN	
Natural Walnut	LWNW

PLASTIC GROMMETS

FOR TABLE TOPS	
Black	E4
Brownstone	EY
Bungalow	EX
Designer White	DW
Flint	E9
Fossil	EH
Loft	EV
Muslin	EU
Parchment	EN
Titanium	TI

RECOMMENDED COORDINATE COLORS

For Plastic Grommets on Laminate specify the same color used for the edge color; or the following plastic grommet color based on edge selected:
 Natural Maple, Fawn Cypress, Natural Recon, Muslin EU
 Phantom Charcoal, Flint E9
 Phantom Ecru, Loft EV
 Portico Teak, Fossil EH
 Shaker Cherry, Black E4
 Skyline Walnut, Flint E9

For Plastic Grommets on Fluid Form specify either same color as painted legs/base; or the following plastic grommet color based on Fluid Form selected:
 Auburn Cherry, Black E4
 Natural Maple, Muslin EU

For Plastic Grommets on Veneer the color is predetermined based on finish selection.
 All Maple veneers, Muslin EU
 All Cherry, Walnut and Dark Rift Cut Oak veneers, Black E4

Forest Stewardship Council (FSC) is a non-profit organization devoted to encouraging the responsible management of the world's forests. FSC sets high standards that ensure forestry is practiced in an environmentally responsible, socially beneficial, and economically viable way. Allsteel received its FSC Chain of Custody certification in 2010 and can offer FSC Certified products. Select wood-based products can be ordered as FSC certified, either by choosing the FSC option or selecting an FSC laminate or veneer finish at the time of order. For more information, please contact Customer Support at 888-255-7833. (FSC Trademark license code: FSC-CO14704.)

All of Allsteel's tables are level® – 2 certified to the ANSI/BIFMA e3 Furniture Sustainability Standard. See www.levelcertified.org for more information.

NOTE: Refer to individual product pages for upcharges.

Structure Bases

***Indicates widest width to determine knee space

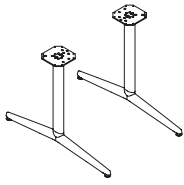

Large T Base — 29"H
Available in glides or casters.
***36½"

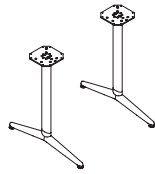

Medium T Base* — 29"H
Available in glides or casters.
***25½"

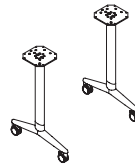

Small T Base* — 29"H
Available in glides or casters.
***19½"

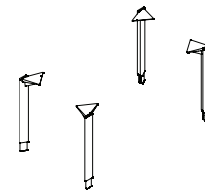

Post-Legs — Fixed or 6" Adjustable
Height — 29"H
Available in glides or casters.

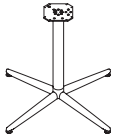

Large X Base — 18", 27", 29"H
Glides only.
***36½"

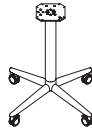

Medium X Base* — 18", 27",
29", 36", 42"H
Available in glides or casters.
***28½"

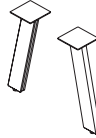

Community Legs — 29"H
Glides only.



Small Cylinder — 29"H
Glides only.
***18"

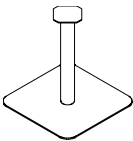

Large Square Pedestal —
18", 27", 29", 36", 42"H
Glides only.
***25"

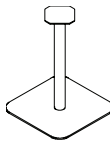

Medium Square Pedestal —
18", 27", 29", 36", 42"H
Glides only.
***20"

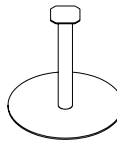

Large Round Pedestal —
18", 27", 29", 36", 42"H
Glides only.
***28"

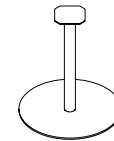

Medium Round Pedestal —
18", 27", 29", 36", 42"H
Glides only.
***24"

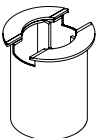

Large Cylinder — 29"H
Glides only.
***20"

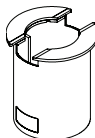

Large Cylinder w/Power
Management — 29"H
Glides only.
***20"

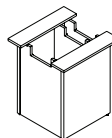

Cube — 29", 42"H
Glides only.
***20"

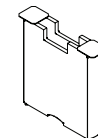

Hollow Panel — 29"
Glides only.
***25½" x 5½"

Power and Wire Management

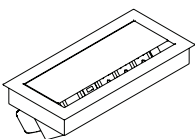

10' Corded Power

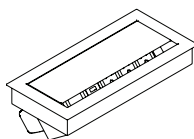

10' Hardwire Power

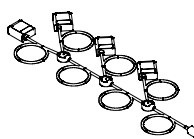

Large Undersurface
Mount Power

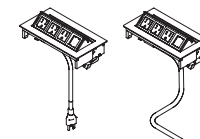

Power/Data Ports

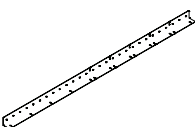

Wall Mount Bracket

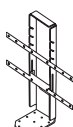

Table Media Mount

Structure Adaptive Tables convert any space into a meeting space.

Adaptive Tables feature a self-centering drop leaf and height-adjustable table top to provide a solution that quickly lifts, lowers, and docks to adapt to spontaneous changes in work and space requirements.



Add Workspace to Existing Worksurfaces

Adaptive Tables feature a self-centering drop leaf and height-adjustable table top allowing the tables to effortlessly dock next to existing worksurfaces. Simply drop the leaf, adjust the height, and dock. The drop leaf is designed to tuck under the worksurface while docking to provide a seamless transition from worksurface to table.

Adaptive table tops are 36" W with the drop leaf up and 22¼" W with the drop leaf down. The bases are 28" in diameter.

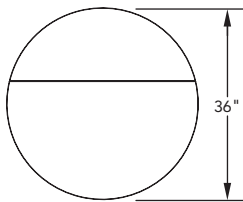

Round
w/Drop Leaf Up

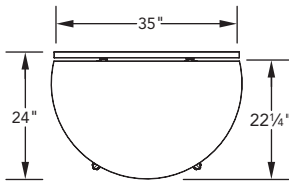

Round
w/Drop Leaf Down

Store Tables Beneath Existing Worksurfaces

Adaptive Tables tuck beneath existing worksurfaces by adjusting the height. Adaptive Tables feature a gas cylinder to provide quiet, smooth movement. Simply pull the height-adjustment lever and push down on the center of the table top to lower the height of the table.

To raise the height of the table, simply pull the height-adjusting lever beneath the edge of the table top and the table will automatically rise. Release the height-adjustment lever to set the table height. Adaptive Tables adjust from 26" H to 33" H.

Convert Table Position from Docked to Freestanding

Adaptive tables quickly convert from a docked position to freestanding by simply pulling the drop leaf up. The self-centering mechanism ensures that the base remains in the center of the table top whether the drop leaf is up or down.

Combine Table Surfaces and Base Finishes

The wide variety of material options and base finishes allow Adaptive Tables to integrate seamlessly into any space. Table tops are available in laminate, with Flat Edge or Knife Edge treatments. Cast aluminum table bases are available with painted or polished aluminum finishes. Polished Aluminum models feature black vertical columns.

Structure tables exceed BIFMA Standards and are backed by the Allsteel lifetime warranty. Die-cast and extruded aluminum components are lightweight, yet highly durable. The self-centering drop leaf has a maximum load capacity of 125 pounds.

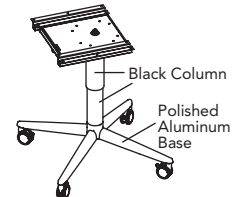

IN-SURFACE POWER

Corded

Corded models plug directly into an outlet and cannot plug into other corded power modules. In order to plug into other units the units need to be hard-wired. When routing corded models to a wall outlet, the maximum amount of cord that can be exposed outside of the furniture is 6 feet.

Hardwire

Hardwire models are provided with 10 feet of sealtight cable. Customers must furnish junction boxes, conduit, and additional wire to be in compliance with local and national codes.

Qi charging is available on Corded and Hardwire versions.

- Includes 3 Qi charging coils (5 watts each) for wireless charging.
- Units have LED indicator lights below the lid's surface.
- Units house power and charging USB inside. All units are Qi certified.
- Cut-outs are centered on single-piece tops.
- Cut-outs are available for round, square, and soft square tops 54" or greater.
- Cut-outs are aligned with the shape of the table.

.C0 - No Cut Out
 .ATE - Small Edge Cut Out, 4" x 8"
 .C1 - 1 Large Center Cut Out, 5" x 11"
 .C2 - 2 Large Center Cut Outs, 5" x 11"
 .C3 - 3 Large Center Cut Outs, 5" x 11"
 .G1 - 1 Small Center Cutout, 4" x 8"

Cutout	Shape	Total Table Length	Value (in)	Dimension			
.ATE	Rectangle	Single-piece tops	1.972	Distance from Edge			
.C2	Rectangle, Racetrack	120	24.45	Distance from Joining Edge			
		144	30.45				
		168	36.45				
		192	24.45				
		216	30.45				
		240	36.45				
	Diamond	Diamond	120	24.45	Distance from Joining Edge		
			144	30.45			
			168	36.45			
			192	42.45			
Square, Round, Soft Square	Square, Round, Soft Square	72	9.49	Distance from Joining Edge			
		84	12.49				
.C1	Media:	54	16.05	Distance from Wall			
	Rectangle, Racetrack, Diamond	60	18.45				
		72	23.25				

STRUCTURE

LARGE PEDESTAL AND X-BASE

2 electrical infeed (0.55" dia.) and 18 voice/data cables (0.25" dia.) at 60% fill ratio. Note: 3.5" diameter column with wire manager.

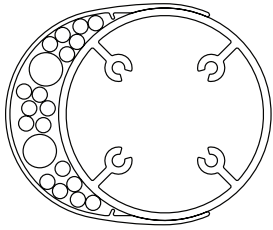

LARGE PEDESTAL AND X-BASE

1 electrical infeed (0.55" dia.) and 23 voice/data cables (0.25" dia.) at 60% fill ratio. Note: 3.5" diameter column with wire manager.

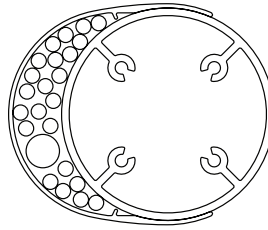

LARGE T LEG

2 electrical infeed (0.55" dia.) and 11 voice/data cables (0.25" dia.) at 60% fill ratio.

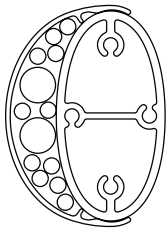

LARGE T LEG

1 electrical infeed (0.55" dia.) and 16 voice/data cables (0.25" dia.) at 60% fill ratio.

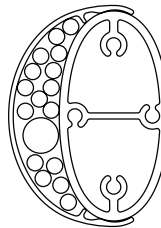

SMALL AND MEDIUM T LEG

2 electrical infeed (0.55" dia.) and 9 voice/data cables (0.25" dia.) at 60% fill ratio.

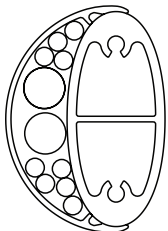

SMALL AND MEDIUM T LEG

1 electrical infeed (0.55" dia.) and 14 voice/data cables (0.25" dia.) at 60% fill ratio.

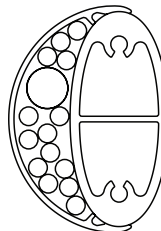

MEDIUM PEDESTAL AND X BASE

2 electrical infeed (0.55" dia.) and 11 voice/data cables (0.25" dia.) at 60% fill ratio.

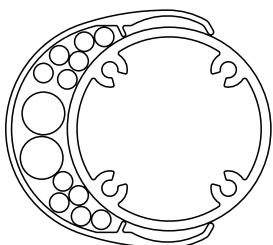

MEDIUM PEDESTAL AND X BASE

1 electrical infeed (0.55" dia.) and 16 voice/data cables (0.25" dia.) at 60% fill ratio.

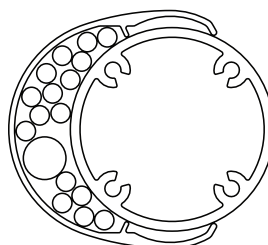

WOOD BASE ELECTRIC CAVITY GUIDE

All wood bases can accommodate cables. The below diagrams document the narrowest opening to plan for when considering which base to order. For the cleanest look and access on a cylinder, consider using AMPTCYLBWM, which includes a larger bottom cavity with door access.

AMPTCYLSM

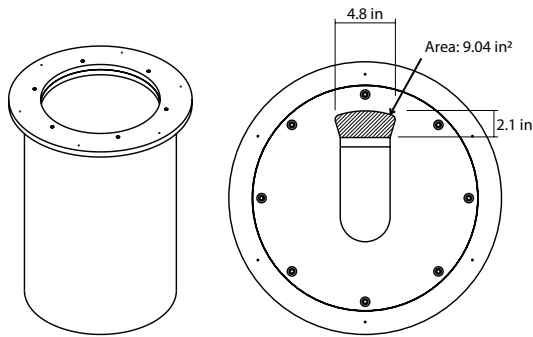

AMPTCYLB

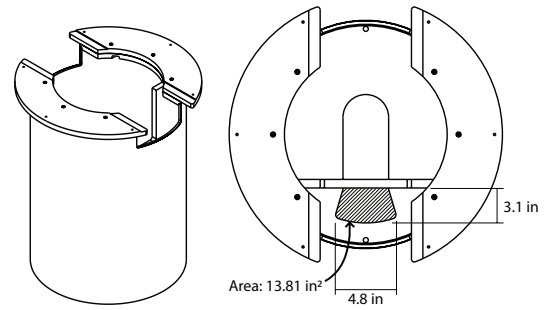

AMPTCYLBWM

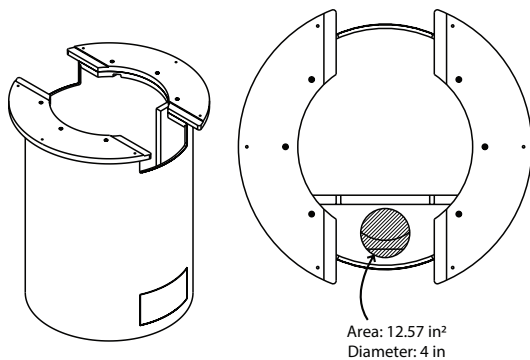

AMPTPANEL

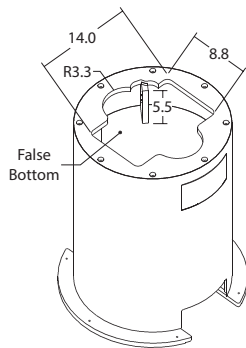
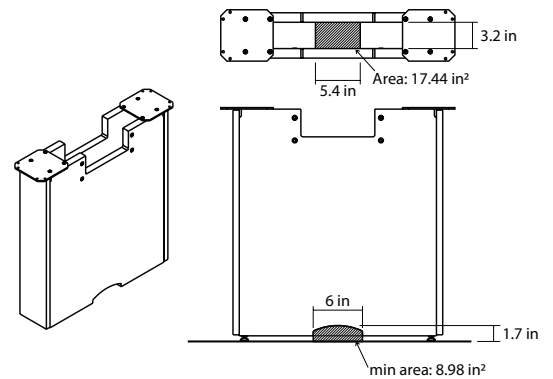

AMPTCUBE

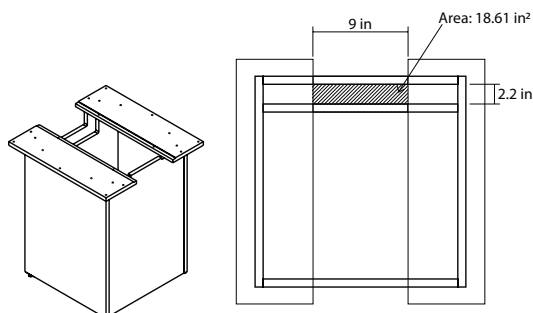

AMPTCUBEST

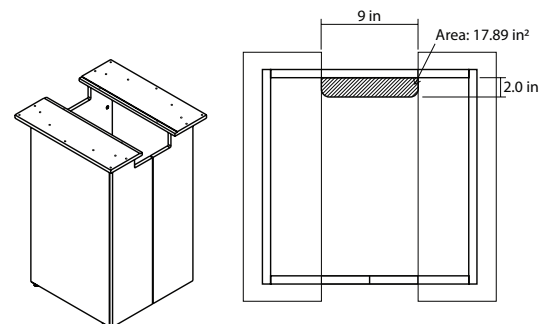

STRUCTURE

Table Dimensions and Base Locations

Base	Shape	36"	42"	48"	52"	54"	60"	72"	84"
Small Cylinder	Diamond					22.5	22.5	22.5	23.0
	Racetrack					18.0	18.0	18.0	18.0
	Rectangle					15.0	15.0	22.0	22.0
Cylinder	Diamond					21.5	21.5	21.5	25.0
	Racetrack					19.0	19.0	19.0	25.0
	Rectangle					19.0	19.0	19.0	25.0
Cube	Diamond					22.0	22.0	22.0	
	Racetrack					22.0	22.0	22.0	23.0
	Rectangle					22.0	22.0	22.0	23.0
Panel	Diamond					15.8	15.8	15.8	15.8
	Racetrack					15.8	15.8	15.8	15.8
	Rectangle					15.8	15.8	15.8	15.8
Community Legs	Diamond							6.2	6.2
	Racetrack 36"W-42"W			7.9			7.9	7.9	7.9
	Racetrack 48"W							7.9	7.9
	Racetrack 54"W								
	Racetrack 60"W								
	Rectangle 36"W			7.2			7.2	7.2	7.2
	Rectangle 42"W-60"W						9.4	9.4	9.4
	Square					14.5	14.5	14.5	14.5
	Soft Square					14.5	14.5	14.5	14.5
Round					14.5	14.5	14.5	14.5	
T-Legs	Boat				5.8		5.8	5.8	
	Diamond							5.8	14.3
	Racetrack 24"W & 36"W	5.8	5.8	5.8			5.8	5.8	14.3
	Racetrack 30"W		7.3	7.3			7.3	7.3	14.3
	Racetrack 42"W							10.7	14.3
	Racetrack 48"W								
Rectangle	5.8	5.8	5.8			5.8	5.8	15.0	
Pedestal/X-base	Boat				13.0		15.0	18.0	
	Diamond							18.3	20.6
	Racetrack						18.4	18.4	20.6
	Rectangle						15.0	18.3	20.6

Note: Dimensions are from edge of table to center of base.

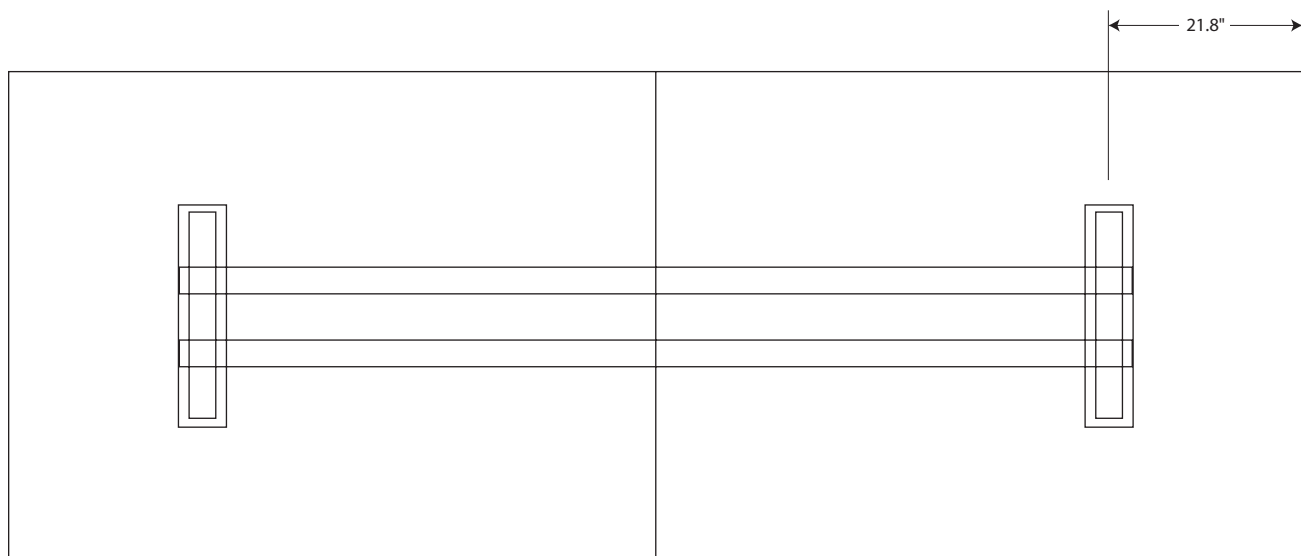
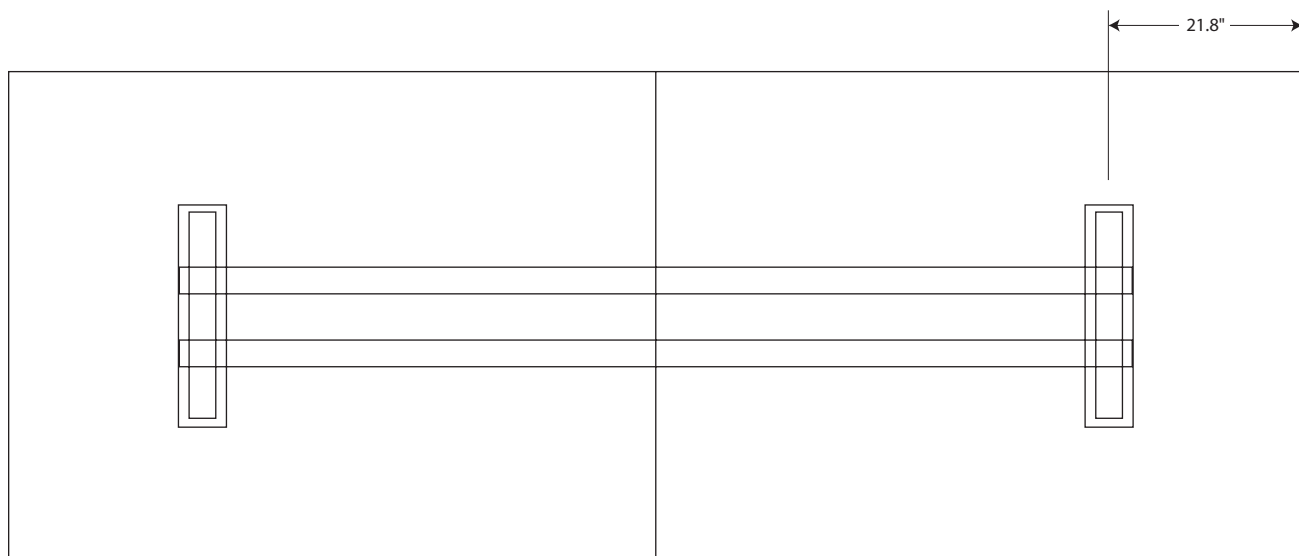

Table Dimensions and Base Locations

Base	Shape	96"	120"	144"	168"	192"	216"	240"
Small Cylinder	Diamond	29.0						
	Racetrack	18.0						
	Rectangle	22.0	29.0	29.0				
Cylinder	Diamond	28.0	28.5	28.5	28.5	28.0		
	Racetrack	28.0	28.5	28.5	28.5	28.0	28.0	28.0
	Rectangle	28.0	28.5	28.5	28.5	28.0	28.0	28.0
Cube	Diamond							
	Racetrack	29.0	29.0	29.0	29.0	29.0	29.0	29.0
	Rectangle	29.0	29.0	29.0	29.0	29.0	29.0	29.0
Panel	Diamond	21.8	21.8	21.8	21.8	21.8		
	Racetrack	21.8	21.8	21.8	21.8	21.8	21.8	21.8
	Rectangle	21.8	21.8	21.8	21.8	21.8	21.8	21.8
Community Legs	Diamond	6.2	22.5	22.5	22.5	22.5		
	Racetrack 36"W-42"W	7.9	8.0	8.0				
	Racetrack 48"W	7.9	11.0	11.0				
	Racetrack 54"W	7.9	14.0	14.0	14.0	14.0	14.0	14.0
	Racetrack 60"W		17.0	17.0	17.0	17.0	17.0	17.0
	Rectangle 36"W	7.2	7.2	7.2				
	Rectangle 42"W-60"W	9.4	9.4	9.4	9.4	9.4	9.4	9.4
	Square							
	Soft Square							
T-Legs	Boat							
	Diamond	18.0						
	Racetrack 24"W & 36"W	18.0						
	Racetrack 30"W							
	Racetrack 42"W	18.0						
	Racetrack 48"W							
	Rectangle	18.0						
Pedestal/X-base	Boat							
	Diamond	23.6	18.0	23.6				
	Racetrack	23.6	18.0	23.6				
	Rectangle	23.6	18.0	23.6				

Note: Dimensions are from edge of table to center of base.



Media Dimensions and Base Locations

Base	Shape	54"	60"	72"
Small Cylinder	Media Diamond	22.5	22.5	22.5
	Media Racetrack	18.0	18.0	18.0
	Media Rectangle	15.0	15.0	22.0
Cylinder	Media Diamond	21.5	21.5	21.5
	Media Racetrack	19.0	19.0	19.0
	Media Rectangle	19.0	19.0	19.0
Cube	Media Diamond	22.0	22.0	22.0
	Media Racetrack	22.0	22.0	22.0
	Media Rectangle	22.0	22.0	22.0
Panel	Media Diamond	15.8	15.8	15.8
	Media Racetrack	15.8	15.8	15.8
	Media Rectangle	15.8	15.8	15.8
Community Legs	Media Diamond	16.5	22.5	22.5
	Media Racetrack 48"W		11.0	
	Media Racetrack 54"W	14.0	14.0	14.0
	Media Racetrack 60"W		17.0	17.0
	Rectangle	9.4	9.4	9.4
Pedestal/X-base	Media Diamond 48"W-54"W	23.6	23.6	23.6
	Media Diamond 60"W		23.6	23.6
	Media Racetrack 48"W-54"W	18.0	18.0	22.0
	Media Racetrack 60"W		18.0	22.0
	Media Rectangle 48"W-54"W	12.0	18.0	22.0
	Media Rectangle 60"W		20.0	22.0

Note: Dimensions are from edge of table to center of base.

STRUCTURE

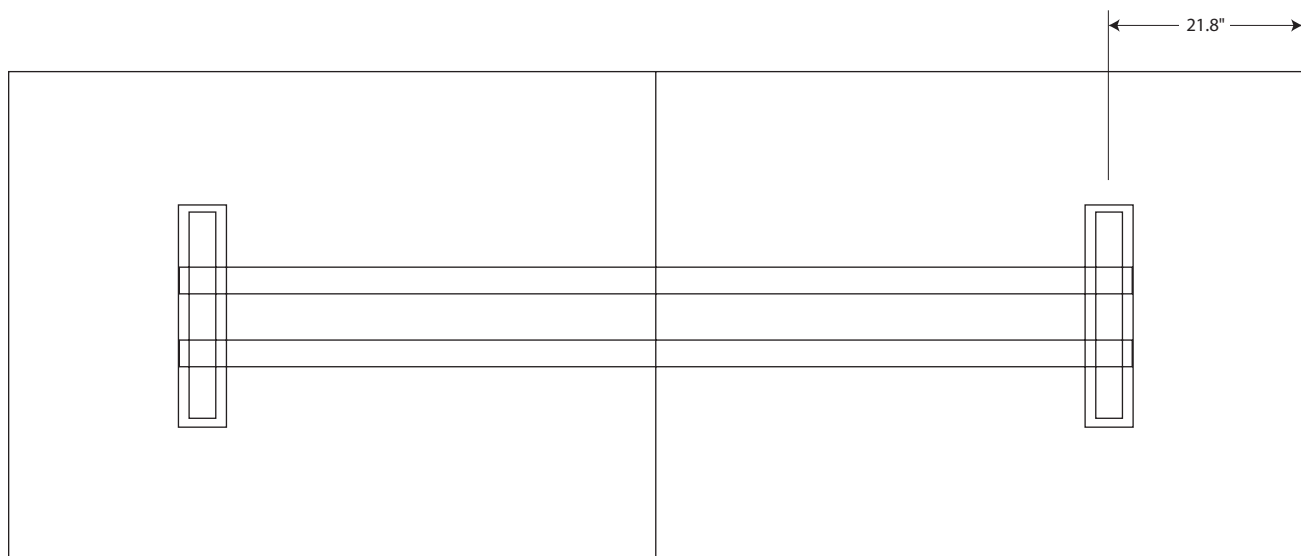

Undersurface Mount Power Configuration Guide

■ = Mini Tap

● = Node

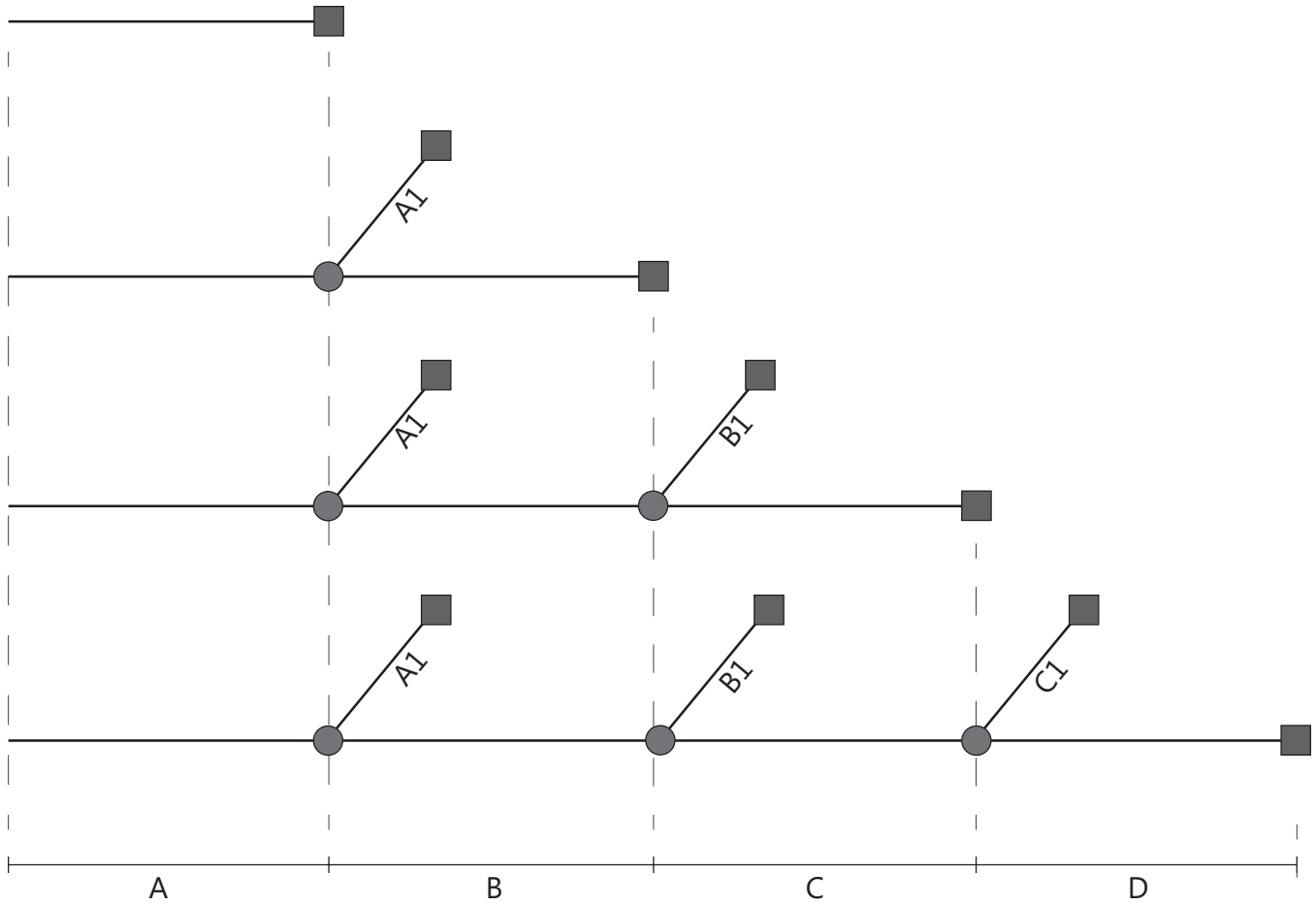

STRUCTURE

	Dimensions (inches)						
	A	A1	B	B1	C	C1	D
AMPTUSPS1A/U	72	-	-	-	-	-	-
AMPTUSPS2	72	36	36	-	-	-	-
AMPTUSPL3	136	43	54	20	72	-	-
AMPTUSPS4	72	20	40	20	40	20	60
AMPTUSPM4	92	20	33	20	24	20	54
AMPTUSPL4	108	23	63	23	28	23	72
AMPTUSPXL4	118	60	60	40	60	28	62

STRUCTURE

Shape	Worksurface Type	Size	Electrical Recommendation	Qty		
Diamond	Small	30x50	AMPTUSPS2	1		
		24x40				
	Single	42x72	AMPTUSPM4	1		
		48x72	AMPTUSPL4	1		
		42x84				
		42x96				
		48x84				
		48x96				
	54x96					
	Multi	48x120	AMPTUSPL3	2		
		48x144				
		54x120				
		54x144				
		54x168				
		60x120				
		60x144				
60x168						
54x192	AMPTUSPXL4	2				
Rectangle	Single	24x36	AMPTUSPS2	1		
		24x42				
		24x48				
		24x60				
		27x72				
		24x84				
		30x42				
		30x48				
		30x60				
		30x72				
		30x84				
		36x48				
		36x60			AMPTUSPM4	1
		36x72				
		42x60				
		42x72				
		48x72			AMPTUSPL4	1
		36x84				
	36x96					
	42x84					
	42x96					
	48x84					
	48x96					
	54x96					
	Multi	42x120	AMPTUSPL3	2		
		42x144				
48x120						
48x144						
54x120						
54x144						
54x168						
60x120						
60x144						
60x168						
60x192		AMPTUSPXL4			2	
60x240						
Boat	Single	30x52	AMPTUSPS2	1		
		30x60				
		30x72				
		36x52	AMPTUSPM4	1		
		36x60				
		36x72				

Shape	Worksurface Type	Size	Electrical Recommendation	Qty		
Racetrack	Single	24x36	AMPTUSPS2	1		
		24x42				
		24x48				
		24x60				
		27x72				
		24x84				
		30x42				
		30x48				
		30x60				
		30x72				
		30x84				
		36x48				
		36x60			AMPTUSPM4	1
		36x72				
		42x60				
		42x72				
		48x72			AMPTUSPL4	1
		36x84				
	36x96					
	42x84					
	42x96					
	48x84					
	48x96					
	54x96					
	Multi	36x120	AMPTUSPL3	2		
		36x144				
		42x120				
		42x144				
		48x120				
		48x144				
		54x120				
		54x144				
		54x168				
		60x120				
		60x144				
		60x168				
54x192		AMPTUSPXL4			2	
54x216						
54x240						
60x192						
60x216						
60x240						
Square, Round, Soft Square	Single	24x24	AMPTUSPS2	1		
		30x30				
		36x36				
	Multi	42x42	AMPTUSPS4	1		
		48x48				
		54x54				
72x72	AMPTUSPXL4	1				
Media: Rectangle/Racetrack/Diamond	Media	48x54	AMPTUSPS2 or AMPTUSPS4	1		
		48x60				
		54x54				
		54x60				
		54x72				
		60x60				
		60x72				

Undersurface Mount Power Configuration Guide

■ = Mini Tap

● = Node

AMPTUSPS1A/U
1 Module

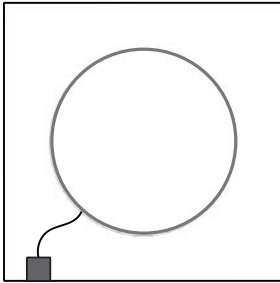

AMPTUSPS2
2 Modules

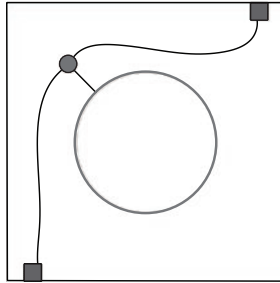

AMPTUSPS4
4 Modules

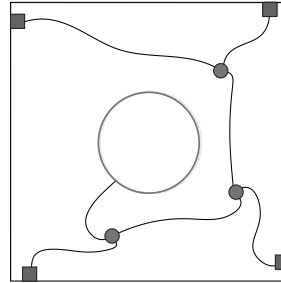

AMPTUSPL3
3 Modules

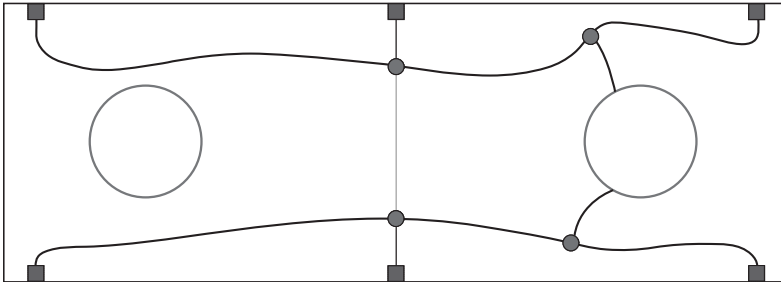

AMPTUSPM4
4 Modules

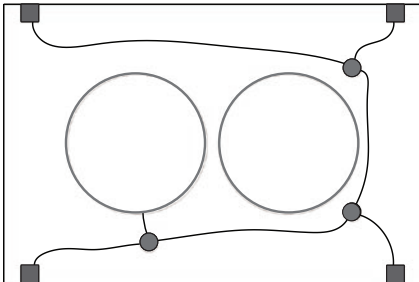

AMPTUSPL4
4 Modules

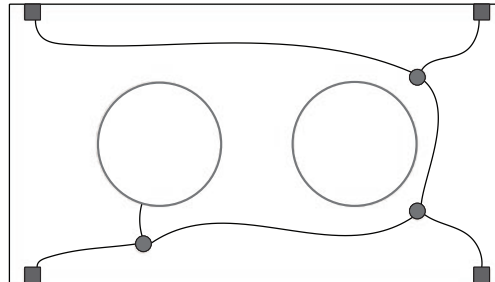

AMPTUSPXL4
4 Modules

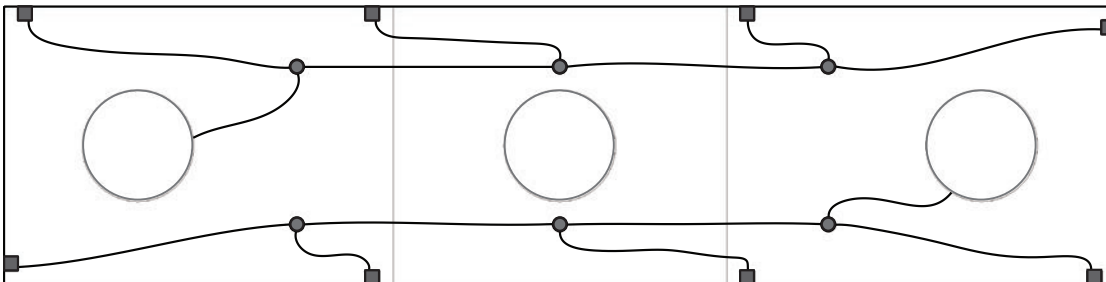

STRUCTURE

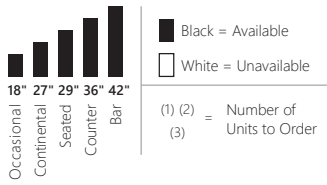







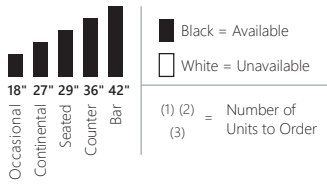





















These top and base combinations are recommended and approved for optimal knee clearance, stability, and aesthetics. Required base and leg quantities are based on top size and shape. Please reference the Price and Specification Guide for more details.

TOPS		AVAILABLE WIDTHS	MEDIUM ROUND PEDESTAL	LARGE ROUND PEDESTAL	MEDIUM SQUARE PEDESTAL	LARGE SQUARE PEDESTAL	MEDIUM X BASE	LARGE X BASE	SMALL CYLINDER	CYLINDER (W/M)	CYLINDER (NO W/M)	
SQUARE	□	24"	▬▬▬ (1)	N/A	▬▬▬ (1)	N/A	N/A	N/A	N/A	N/A	N/A	
		30"	▬▬▬ (1)	N/A	▬▬▬ (1)	N/A	▬▬▬ (1)	N/A	N/A	N/A	N/A	
		36"	▬▬▬ (1)	N/A	▬▬▬ (1)	N/A	▬▬▬ (1)	N/A	▬▬▬▬ (1)	▬▬▬▬ (1)	▬▬▬▬ (1)	
		42"	N/A	▬▬▬ (1)	N/A	▬▬▬ (1)	N/A	▬▬▬▬ (1)	▬▬▬▬ (1)	▬▬▬▬ (1)	▬▬▬▬ (1)	
		48"	N/A	▬▬▬ (1)	N/A	▬▬▬ (1)	N/A	▬▬▬▬ (1)	▬▬▬▬ (1)	▬▬▬▬ (1)	▬▬▬▬ (1)	
		54" 60"	N/A	N/A	N/A	N/A	N/A	N/A	N/A	N/A	N/A	N/A
		72" 84"	N/A	N/A	N/A	N/A	N/A	N/A	N/A	N/A	N/A	N/A
ROUND	○	24"	▬▬▬ (1)	N/A	N/A	N/A	N/A	N/A	N/A	N/A	N/A	
		30"	▬▬▬ (1)	N/A	▬▬▬ (1)	N/A	▬▬▬ (1)	N/A	N/A	N/A	N/A	
		36"	▬▬▬ (1)	N/A	▬▬▬ (1)	N/A	▬▬▬ (1)	N/A	▬▬▬▬ (1)	▬▬▬▬ (1)	▬▬▬▬ (1)	
		42"	N/A	▬▬▬ (1)	N/A	▬▬▬ (1)	N/A	▬▬▬▬ (1)	▬▬▬▬ (1)	▬▬▬▬ (1)	▬▬▬▬ (1)	
		48"	N/A	▬▬▬ (1)	N/A	▬▬▬ (1)	N/A	▬▬▬▬ (1)	▬▬▬▬ (1)	▬▬▬▬ (1)	▬▬▬▬ (1)	
		54" 60"	N/A	N/A	N/A	N/A	N/A	N/A	N/A	▬▬▬▬ (1)	▬▬▬▬ (1)	
		72" 84"	N/A	N/A	N/A	N/A	N/A	N/A	N/A	N/A	N/A	
SOFT SQUARE	◻	24"	▬▬▬ (1)	N/A	▬▬▬ (1)	N/A	N/A	N/A	N/A	N/A	N/A	
		30"	▬▬▬ (1)	N/A	▬▬▬ (1)	N/A	▬▬▬ (1)	N/A	N/A	N/A	N/A	
		36"	▬▬▬ (1)	N/A	▬▬▬ (1)	N/A	▬▬▬ (1)	N/A	▬▬▬▬ (1)	▬▬▬▬ (1)	▬▬▬▬ (1)	
		42"	N/A	▬▬▬ (1)	N/A	▬▬▬ (1)	N/A	▬▬▬▬ (1)	▬▬▬▬ (1)	▬▬▬▬ (1)	▬▬▬▬ (1)	
		48"	N/A	▬▬▬ (1)	N/A	▬▬▬ (1)	N/A	▬▬▬▬ (1)	▬▬▬▬ (1)	▬▬▬▬ (1)	▬▬▬▬ (1)	
		54" 60"	N/A	N/A	N/A	N/A	N/A	N/A	N/A	N/A	N/A	
		72" 84"	N/A	N/A	N/A	N/A	N/A	N/A	N/A	N/A	N/A	
BOAT	30"x52" 30"x60" 30"x72" 36"x52" 36"x60" 36"x72"	▬▬▬ (2)	N/A	▬▬▬ (2)	N/A	▬▬▬ (2)	N/A	N/A	N/A	N/A		

STRUCTURE



These top and base combinations are recommended and approved for optimal knee clearance, stability, and aesthetics. Required base and leg quantities are based on top size and shape. Please reference the Price and Specification Guide for more details.

TOPS		AVAILABLE WIDTHS	CUBE 	PANEL 	SMALL T LEGS 	MEDIUM T LEGS 	LARGE T LEGS 	FIXED POST-LEGS 	ADJUSTABLE POST-LEGS 	COMMUNITY LEGS 
SQUARE	□	24"	N/A	N/A	N/A	N/A	N/A	N/A	N/A	N/A
		30"	N/A	N/A	N/A	N/A	N/A	 (1 kit of 4)	 (1 kit of 4)	N/A
		36"	N/A	N/A	N/A	N/A	N/A	 (1 kit of 4)	 (1 kit of 4)	N/A
		42"	N/A	N/A	N/A	N/A	N/A	 (1 kit of 4)	 (1 kit of 4)	N/A
		48"	 (1)	N/A	N/A	N/A	N/A	 (1 kit of 4)	 (1 kit of 4)	N/A
		54" 60"	 (1)	N/A	N/A	N/A	N/A	N/A	N/A	 (1 kit of 4)
		72" 84"	N/A	N/A	N/A	N/A	N/A	N/A	N/A	 (1 kit of 4)
ROUND	○	24"	N/A	N/A	N/A	N/A	N/A	N/A	N/A	N/A
		30"	N/A	N/A	N/A	N/A	N/A	N/A	N/A	N/A
		36"	N/A	N/A	N/A	N/A	N/A	N/A	N/A	N/A
		42"	N/A	N/A	N/A	N/A	N/A	N/A	N/A	N/A
		48"	 (1)	N/A	N/A	N/A	N/A	N/A	N/A	N/A
		54" 60"	 (1)	N/A	N/A	N/A	N/A	N/A	N/A	 (1 kit of 4)
		72" 84"	N/A	N/A	N/A	N/A	N/A	N/A	N/A	 (1 kit of 4)
SOFT SQUARE	◻	24"	N/A	N/A	N/A	N/A	N/A	N/A	N/A	N/A
		30"	N/A	N/A	N/A	N/A	N/A	N/A	N/A	N/A
		36"	N/A	N/A	N/A	N/A	N/A	N/A	N/A	N/A
		42"	N/A	N/A	N/A	N/A	N/A	N/A	N/A	N/A
		48"	 (1)	N/A	N/A	N/A	N/A	N/A	N/A	N/A
		54" 60"	 (1)	N/A	N/A	N/A	N/A	N/A	N/A	 (1 kit of 4)
		72" 84"	N/A	N/A	N/A	N/A	N/A	N/A	N/A	 (1 kit of 4)
BOAT	◻	30"x52" 30"x60" 30"x72" 36"x52" 36"x60" 36"x72"	N/A	N/A	N/A	 (1 kit of 2)	N/A	N/A	N/A	N/A

STRUCTURE

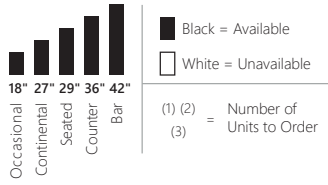

These top and base combinations are recommended and approved for optimal knee clearance, stability, and aesthetics. Required base and leg quantities are based on top size and shape. Please reference the Price and Specification Guide for more details.

TOPS	AVAILABLE WIDTHS	MEDIUM ROUND PEDESTAL	LARGE ROUND PEDESTAL	MEDIUM SQUARE PEDESTAL	LARGE SQUARE PEDESTAL	MEDIUM X BASE	LARGE X BASE	SMALL CYLINDER	CYLINDER (W/M)	CYLINDER (NO W/M)
MEDIA RECTANGLE	48"x54" 48"x60" 54"x54" 54"x60" 54"x72"	■ ■ ■ (1)	N/A	■ ■ ■ (1)	N/A	■ ■ ■ (1)	N/A	■ ■ ■ (1)	■ ■ ■ (1)	■ ■ ■ (1)
	60"x60" 60"x72"	N/A	■ ■ ■ (1)	N/A	■ ■ ■ (1)	N/A	■ ■ ■ (1)	■ ■ ■ (1)	■ ■ ■ (1)	■ ■ ■ (1)
MEDIA DIAMOND	48"x54" 48"x60" 54"x54" 54"x60" 54"x72"	■ ■ ■ (1)	N/A	■ ■ ■ (1)	N/A	■ ■ ■ (1)	N/A	■ ■ ■ (1)	■ ■ ■ (1)	■ ■ ■ (1)
	60"x60" 60"x72"	N/A	■ ■ ■ (1)	N/A	■ ■ ■ (1)	N/A	■ ■ ■ (1)	■ ■ ■ (1)	■ ■ ■ (1)	■ ■ ■ (1)
MEDIA RACETRACK	48"x54" 48"x60" 54"x54" 54"x60" 54"x72"	■ ■ ■ (1)	N/A	■ ■ ■ (1)	N/A	■ ■ ■ (1)	N/A	■ ■ ■ (1)	■ ■ ■ (1)	■ ■ ■ (1)
	60"x60" 60"x72"	N/A	■ ■ ■ (1)	N/A	■ ■ ■ (1)	N/A	■ ■ ■ (1)	■ ■ ■ (1)	■ ■ ■ (1)	■ ■ ■ (1)
DIAMOND	24"x40"	■ ■ ■ (1)	N/A	N/A	N/A	N/A	N/A	N/A	N/A	N/A
	30"x50"	N/A	■ ■ ■ (1)	N/A	■ ■ ■ (1)	N/A	N/A	N/A	N/A	N/A
	42"x72"	N/A	■ ■ ■ (2)	N/A	■ ■ ■ (2)	N/A	■ ■ ■ (2)	N/A	■ ■ ■ (2)	■ ■ ■ (2)
	42"x84" 42"x96"	N/A	■ ■ ■ (2)	N/A	■ ■ ■ (2)	N/A	■ ■ ■ (2)	■ ■ ■ (2)	■ ■ ■ (1 kit of 2)	■ ■ ■ (1 kit of 2)
	48"x72"	N/A	■ ■ ■ (2)	N/A	■ ■ ■ (2)	N/A	■ ■ ■ (2)	N/A	■ ■ ■ (2)	■ ■ ■ (2)
	48"x84" 48"x96"	N/A	■ ■ ■ (2)	N/A	■ ■ ■ (2)	N/A	■ ■ ■ (2)	N/A	■ ■ ■ (1 kit of 2)	■ ■ ■ (1 kit of 2)
	48"x120"	N/A	■ ■ ■ (2)	N/A	■ ■ ■ (2)	N/A	■ ■ ■ (2)	N/A	■ ■ ■ (1 kit of 2)	■ ■ ■ (1 kit of 2)
	48"x144"	N/A	■ ■ ■ (3)	N/A	■ ■ ■ (3)	N/A	■ ■ ■ (3)	N/A	■ ■ ■ (1 kit of 2)	■ ■ ■ (1 kit of 2)
	54"x96"	N/A	■ ■ ■ (2)	N/A	■ ■ ■ (2)	N/A	■ ■ ■ (2)	N/A	■ ■ ■ (1 kit of 2)	■ ■ ■ (1 kit of 2)
	54"x120" 54"x144"	N/A	N/A	N/A	N/A	N/A	N/A	N/A	■ ■ ■ (1 kit of 2)	■ ■ ■ (1 kit of 2)
	54"x168"	N/A	N/A	N/A	N/A	N/A	N/A	N/A	■ ■ ■ (1 kit of 2)	■ ■ ■ (1 kit of 2)
	54"x192"	N/A	N/A	N/A	N/A	N/A	N/A	N/A	■ ■ ■ (1 kit of 3)	■ ■ ■ (1 kit of 3)
	60"x120" 60"x144"	N/A	N/A	N/A	N/A	N/A	N/A	N/A	■ ■ ■ (1 kit of 2)	■ ■ ■ (1 kit of 2)
	60"x168"	N/A	N/A	N/A	N/A	N/A	N/A	N/A	■ ■ ■ (1 kit of 2)	■ ■ ■ (1 kit of 2)
60"x192"	N/A	N/A	N/A	N/A	N/A	N/A	N/A	■ ■ ■ (1 kit of 3)	■ ■ ■ (1 kit of 3)	

Structure

Top-Base Compatibility Matrix

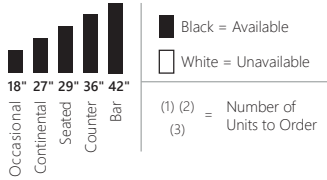

These top and base combinations are recommended and approved for optimal knee clearance, stability, and aesthetics. Required base and leg quantities are based on top size and shape. Please reference the Price and Specification Guide for more details.

TOPS	AVAILABLE WIDTHS	CUBE	PANEL	SMALL T LEGS	MEDIUM T LEGS	LARGE T LEGS	FIXED POST-LEGS	ADJUSTABLE POST-LEGS	COMMUNITY LEGS
MEDIA RECTANGLE	48"x54" 48"x60" 54"x54" 54"x60" 54"x72"	(1)	(1)	N/A	N/A	N/A	N/A	N/A	(1 kit of 2)
	60"x60" 60"x72"	(1)	(1)	N/A	N/A	N/A	N/A	N/A	(1 kit of 2)
MEDIA DIAMOND	48"x54" 48"x60" 54"x54" 54"x60" 54"x72"	(1)	(1)	N/A	N/A	N/A	N/A	N/A	(1 kit of 2)
	60"x60" 60"x72"	(1)	(1)	N/A	N/A	N/A	N/A	N/A	(1 kit of 2)
MEDIA RACETRACK	48"x54" 48"x60" 54"x54" 54"x60" 54"x72"	(1)	(1)	N/A	N/A	N/A	N/A	N/A	(1 kit of 2)
	60"x60" 60"x72"	(1)	(1)	N/A	N/A	N/A	N/A	N/A	(1 kit of 2)
DIAMOND	24"x40"	N/A	N/A	N/A	N/A	N/A	N/A	N/A	N/A
	30"x50"	N/A	N/A	N/A	N/A	N/A	N/A	N/A	N/A
	42"x72"	N/A	N/A	N/A	(1 kit of 2)	N/A	N/A	N/A	(1 kit of 4)
	42"x84" 42"x96"	N/A	N/A	N/A	(1 kit of 2)	N/A	N/A	N/A	(1 kit of 4)
	48"x72"	N/A	(2)	N/A	N/A	(1 kit of 2)	N/A	N/A	(1 kit of 4)
	48"x84" 48"x96"	N/A	(1 kit of 2)	N/A	N/A	(1 kit of 2)	N/A	N/A	(1 kit of 4)
	48"x120"	N/A	(1 kit of 2)	N/A	N/A	N/A	N/A	N/A	(1 kit of 6)
	48"x144"	N/A	(1 kit of 2)	N/A	N/A	N/A	N/A	N/A	(1 kit of 6)
	54"x96"	N/A	(1 kit of 2)	N/A	N/A	N/A	N/A	N/A	(1 kit of 4)
	54"x120" 54"x144"	N/A	(1 kit of 2)	N/A	N/A	N/A	N/A	N/A	(1 kit of 6)
	54"x168"	N/A	(1 kit of 3)	N/A	N/A	N/A	N/A	N/A	(1 kit of 6)
	54"x192"	N/A	(1 kit of 3)	N/A	N/A	N/A	N/A	N/A	(1 kit of 6)
	60"x120" 60"x144"	N/A	(1 kit of 2)	N/A	N/A	N/A	N/A	N/A	(1 kit of 6)
	60"x168"	N/A	(1 kit of 3)	N/A	N/A	N/A	N/A	N/A	(1 kit of 6)
60"x192"	N/A	(1 kit of 3)	N/A	N/A	N/A	N/A	N/A	(1 kit of 6)	

STRUCTURE

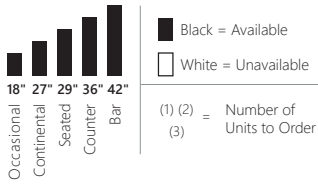

These top and base combinations are recommended and approved for optimal knee clearance, stability, and aesthetics. Required base and leg quantities are based on top size and shape. Please reference the Price and Specification Guide for more details.

TOP	AVAILABLE WIDTHS	MEDIUM ROUND PEDESTAL	LARGE ROUND PEDESTAL	MEDIUM SQUARE PEDESTAL	LARGE SQUARE PEDESTAL	MEDIUM X BASE	LARGE X BASE	SMALL CYLINDER	CYLINDER (W/M)	CYLINDER (NO W/M)	
RECTANGLE	24"x36"	■ ■ ■ (1)	N/A	■ ■ ■ (1)	N/A	N/A	N/A	N/A	N/A	N/A	
	24"x42"	N/A	N/A	N/A	N/A	N/A	N/A	N/A	N/A	N/A	
	24"x48"	N/A	N/A	N/A	N/A	N/A	N/A	N/A	N/A	N/A	
	24"x60"	■ ■ ■ (2)	N/A	■ ■ ■ (2)	N/A	N/A	N/A	N/A	N/A	N/A	
	24"x72"	■ ■ ■ (2)	N/A	■ ■ ■ (2)	N/A	N/A	N/A	N/A	N/A	N/A	
	24"x84"	■ ■ ■ (2)	N/A	■ ■ ■ (2)	N/A	N/A	N/A	N/A	N/A	N/A	
	30"x42"	N/A	■ ■ ■ (1)	N/A	■ ■ ■ (1)	N/A	■ ■ ■ (1)	■ ■ ■ (1)	■ ■ ■ (1)	■ ■ ■ (1)	■ ■ ■ (1)
	30"x48"	N/A	■ ■ ■ (1)	N/A	■ ■ ■ (1)	N/A	■ ■ ■ (1)	■ ■ ■ (1)	N/A	■ ■ ■ (1)	■ ■ ■ (1)
	30"x60"	■ ■ ■ (2)	N/A	■ ■ ■ (2)	N/A	■ ■ ■ (2)	N/A	N/A	N/A	N/A	N/A
	30"x72"	■ ■ ■ (2)	N/A	■ ■ ■ (2)	N/A	■ ■ ■ (2)	N/A	N/A	N/A	N/A	N/A
	30"x84"	■ ■ ■ (2)	N/A	■ ■ ■ (2)	N/A	■ ■ ■ (2)	N/A	N/A	N/A	N/A	N/A
	36"x48"	N/A	■ ■ ■ (1)	N/A	■ ■ ■ (1)	N/A	■ ■ ■ (1)	■ ■ ■ (1)	N/A	■ ■ ■ (1)	■ ■ ■ (1)
	36"x60"	■ ■ ■ (2)	N/A	■ ■ ■ (2)	N/A	■ ■ ■ (2)	N/A	N/A	N/A	N/A	N/A
	36"x72"	■ ■ ■ (2)	N/A	■ ■ ■ (2)	N/A	■ ■ ■ (2)	N/A	N/A	■ ■ ■ (2)	■ ■ ■ (2)	■ ■ ■ (2)
	36"x84"	■ ■ ■ (2)	N/A	■ ■ ■ (2)	N/A	■ ■ ■ (2)	N/A	N/A	■ ■ ■ (2)	■ ■ ■ (1 kit of 2)	■ ■ ■ (1 kit of 2)
	36"x96"	■ ■ ■ (2)	N/A	■ ■ ■ (2)	N/A	■ ■ ■ (2)	N/A	N/A	■ ■ ■ (2)	■ ■ ■ (1 kit of 2)	■ ■ ■ (1 kit of 2)
	36"x120"	■ ■ ■ (2)	N/A	■ ■ ■ (2)	N/A	■ ■ ■ (2)	N/A	N/A	■ ■ ■ (2)	■ ■ ■ (1 kit of 2)	■ ■ ■ (1 kit of 2)
	36"x144"	■ ■ ■ (3)	N/A	■ ■ ■ (3)	N/A	■ ■ ■ (3)	N/A	N/A	■ ■ ■ (2)	■ ■ ■ (1 kit of 2)	■ ■ ■ (1 kit of 2)
	42"x60"	N/A	■ ■ ■ (2)	N/A	■ ■ ■ (2)	N/A	■ ■ ■ (2)	■ ■ ■ (2)	■ ■ ■ (2)	■ ■ ■ (2)	■ ■ ■ (2)
	42"x72"	N/A	■ ■ ■ (2)	N/A	■ ■ ■ (2)	N/A	■ ■ ■ (2)	■ ■ ■ (2)	■ ■ ■ (2)	■ ■ ■ (2)	■ ■ ■ (2)
	42"x84"	N/A	■ ■ ■ (2)	N/A	■ ■ ■ (2)	N/A	■ ■ ■ (2)	■ ■ ■ (2)	■ ■ ■ (2)	■ ■ ■ (1 kit of 2)	■ ■ ■ (1 kit of 2)
	42"x96"	N/A	■ ■ ■ (2)	N/A	■ ■ ■ (2)	N/A	■ ■ ■ (2)	■ ■ ■ (2)	■ ■ ■ (2)	■ ■ ■ (1 kit of 2)	■ ■ ■ (1 kit of 2)
	42"x120"	N/A	■ ■ ■ (2)	N/A	■ ■ ■ (2)	N/A	■ ■ ■ (2)	■ ■ ■ (2)	■ ■ ■ (2)	■ ■ ■ (1 kit of 2)	■ ■ ■ (1 kit of 2)
	42"x144"	N/A	■ ■ ■ (3)	N/A	■ ■ ■ (3)	N/A	■ ■ ■ (3)	■ ■ ■ (3)	■ ■ ■ (2)	■ ■ ■ (1 kit of 2)	■ ■ ■ (1 kit of 2)
	48"x72"	N/A	■ ■ ■ (2)	N/A	■ ■ ■ (2)	N/A	■ ■ ■ (2)	■ ■ ■ (2)	N/A	■ ■ ■ (2)	■ ■ ■ (2)
	48"x84"	N/A	■ ■ ■ (2)	N/A	■ ■ ■ (2)	N/A	■ ■ ■ (2)	■ ■ ■ (2)	N/A	■ ■ ■ (1 kit of 2)	■ ■ ■ (1 kit of 2)
	48"x96"	N/A	■ ■ ■ (2)	N/A	■ ■ ■ (2)	N/A	■ ■ ■ (2)	■ ■ ■ (2)	N/A	■ ■ ■ (1 kit of 2)	■ ■ ■ (1 kit of 2)
	48"x120"	N/A	■ ■ ■ (2)	N/A	■ ■ ■ (2)	N/A	■ ■ ■ (2)	■ ■ ■ (2)	N/A	■ ■ ■ (1 kit of 2)	■ ■ ■ (1 kit of 2)
	48"x144"	N/A	■ ■ ■ (3)	N/A	■ ■ ■ (3)	N/A	■ ■ ■ (3)	■ ■ ■ (3)	N/A	■ ■ ■ (1 kit of 2)	■ ■ ■ (1 kit of 2)
	54"x96"	N/A	N/A	N/A	N/A	N/A	N/A	N/A	N/A	■ ■ ■ (1 kit of 2)	■ ■ ■ (1 kit of 2)
54"x120"	N/A	N/A	N/A	N/A	N/A	N/A	N/A	N/A	■ ■ ■ (1 kit of 2)	■ ■ ■ (1 kit of 2)	
54"x144"	N/A	N/A	N/A	N/A	N/A	N/A	N/A	N/A	■ ■ ■ (1 kit of 2)	■ ■ ■ (1 kit of 2)	
54"x168"	N/A	N/A	N/A	N/A	N/A	N/A	N/A	N/A	■ ■ ■ (1 kit of 2)	■ ■ ■ (1 kit of 2)	
54"x192"	N/A	N/A	N/A	N/A	N/A	N/A	N/A	N/A	■ ■ ■ (1 kit of 3)	■ ■ ■ (1 kit of 3)	
54"x216"	N/A	N/A	N/A	N/A	N/A	N/A	N/A	N/A	■ ■ ■ (1 kit of 3)	■ ■ ■ (1 kit of 3)	
54"x240"	N/A	N/A	N/A	N/A	N/A	N/A	N/A	N/A	■ ■ ■ (1 kit of 3)	■ ■ ■ (1 kit of 3)	
60"x120"	N/A	N/A	N/A	N/A	N/A	N/A	N/A	N/A	■ ■ ■ (1 kit of 2)	■ ■ ■ (1 kit of 2)	
60"x144"	N/A	N/A	N/A	N/A	N/A	N/A	N/A	N/A	■ ■ ■ (1 kit of 2)	■ ■ ■ (1 kit of 2)	
60"x168"	N/A	N/A	N/A	N/A	N/A	N/A	N/A	N/A	■ ■ ■ (1 kit of 2)	■ ■ ■ (1 kit of 2)	
60"x192"	N/A	N/A	N/A	N/A	N/A	N/A	N/A	N/A	■ ■ ■ (1 kit of 3)	■ ■ ■ (1 kit of 3)	
60"x216"	N/A	N/A	N/A	N/A	N/A	N/A	N/A	N/A	■ ■ ■ (1 kit of 3)	■ ■ ■ (1 kit of 3)	
60"x240"	N/A	N/A	N/A	N/A	N/A	N/A	N/A	N/A	■ ■ ■ (1 kit of 3)	■ ■ ■ (1 kit of 3)	

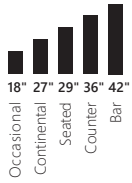

Black = Available
 White = Unavailable
 (1) (2) = Number of Units to Order
 (3) =

These top and base combinations are recommended and approved for optimal knee clearance, stability, and aesthetics. Required base and leg quantities are based on top size and shape. Please reference the Price and Specification Guide for more details.

TOP	AVAILABLE WIDTHS	CUBE	PANEL	SMALL T LEGS	MEDIUM T LEGS	LARGE T LEGS	FIXED POST-LEGS	ADJUSTABLE POST-LEGS	COMMUNITY LEGS
RECTANGLE	24"x36"	N/A	N/A	(1 kit of 2)	N/A	N/A	(1 kit of 4)	(1 kit of 4)	N/A
	24"x42"	N/A	N/A	(1 kit of 2)	N/A	N/A	(1 kit of 4)	(1 kit of 4)	N/A
	24"x48"	N/A	N/A	(1 kit of 2)	N/A	N/A	(1 kit of 4)	(1 kit of 4)	N/A
	24"x60"	N/A	N/A	(1 kit of 2)	N/A	N/A	(1 kit of 4)	(1 kit of 4)	N/A
	24"x72"	N/A	N/A	(1 kit of 2)	N/A	N/A	N/A	N/A	N/A
	24"x84"	N/A	N/A	(1 kit of 2)	N/A	N/A	N/A	N/A	N/A
	30"x42"	N/A	N/A	N/A	(1 kit of 2)	N/A	N/A	N/A	N/A
	30"x48"	N/A	N/A	N/A	(1 kit of 2)	N/A	(1 kit of 4)	(1 kit of 4)	N/A
	30"x60"	N/A	N/A	N/A	(1 kit of 2)	N/A	(1 kit of 4)	(1 kit of 4)	N/A
	30"x72"	N/A	N/A	N/A	(1 kit of 2)	N/A	N/A	N/A	N/A
	30"x84"	N/A	N/A	N/A	(1 kit of 2)	N/A	N/A	N/A	N/A
	36"x48"	N/A	N/A	N/A	(1 kit of 2)	N/A	(1 kit of 4)	(1 kit of 4)	(1 kit of 4)
	36"x60"	N/A	(2)	N/A	(1 kit of 2)	N/A	N/A	N/A	(1 kit of 4)
	36"x72"	N/A	(2)	N/A	(1 kit of 2)	N/A	N/A	N/A	(1 kit of 4)
	36"x84"	N/A	(1 kit of 2)	N/A	(1 kit of 2)	N/A	N/A	N/A	(1 kit of 4)
	36"x96"	N/A	(1 kit of 2)	N/A	(1 kit of 2)	N/A	N/A	N/A	(1 kit of 4)
	36"x120"	N/A	(1 kit of 2)	N/A	N/A	N/A	N/A	N/A	(1 kit of 6)
	36"x144"	N/A	(1 kit of 2)	N/A	N/A	N/A	N/A	N/A	(1 kit of 6)
	42"x60"	N/A	(2)	N/A	N/A	(1 kit of 2)	N/A	N/A	(1 kit of 4)
	42"x72"	N/A	(2)	N/A	N/A	(1 kit of 2)	N/A	N/A	(1 kit of 4)
	42"x84"	N/A	(1 kit of 2)	N/A	N/A	(1 kit of 2)	N/A	N/A	(1 kit of 4)
	42"x96"	N/A	(1 kit of 2)	N/A	N/A	(1 kit of 2)	N/A	N/A	(1 kit of 4)
	42"x120"	(1 kit of 2)	(1 kit of 2)	N/A	N/A	N/A	N/A	N/A	(1 kit of 6)
	42"x144"	(1 kit of 2)	(1 kit of 2)	N/A	N/A	N/A	N/A	N/A	(1 kit of 6)
	48"x72"	(2)	(2)	N/A	N/A	(1 kit of 2)	N/A	N/A	(1 kit of 4)
	48"x84"	(1 kit of 2)	(1 kit of 2)	N/A	N/A	(1 kit of 2)	N/A	N/A	(1 kit of 4)
	48"x96"	(1 kit of 2)	(1 kit of 2)	N/A	N/A	(1 kit of 2)	N/A	N/A	(1 kit of 4)
	48"x120"	(1 kit of 2)	(1 kit of 2)	N/A	N/A	N/A	N/A	N/A	(1 kit of 6)
	48"x144"	(1 kit of 2)	(1 kit of 2)	N/A	N/A	N/A	N/A	N/A	(1 kit of 6)
	54"x96"	(1 kit of 2)	(1 kit of 2)	N/A	N/A	N/A	N/A	N/A	(1 kit of 4)
54"x120"	(1 kit of 2)	(1 kit of 2)	N/A	N/A	N/A	N/A	N/A	(1 kit of 6)	
54"x144"	(1 kit of 2)	(1 kit of 2)	N/A	N/A	N/A	N/A	N/A	(1 kit of 6)	
54"x168"	(1 kit of 2)	(1 kit of 3)	N/A	N/A	N/A	N/A	N/A	(1 kit of 6)	
54"x192"	(1 kit of 3)	(1 kit of 3)	N/A	N/A	N/A	N/A	N/A	(1 kit of 8)	
54"x216"	(1 kit of 3)	(1 kit of 3)	N/A	N/A	N/A	N/A	N/A	(1 kit of 8)	
54"x240"	(1 kit of 3)	(1 kit of 3)	N/A	N/A	N/A	N/A	N/A	(1 kit of 8)	
60"x120"	(1 kit of 2)	(1 kit of 2)	N/A	N/A	N/A	N/A	N/A	(1 kit of 6)	
60"x144"	(1 kit of 2)	(1 kit of 2)	N/A	N/A	N/A	N/A	N/A	(1 kit of 6)	
60"x168"	(1 kit of 3)	(1 kit of 3)	N/A	N/A	N/A	N/A	N/A	(1 kit of 6)	
60"x192"	(1 kit of 3)	(1 kit of 3)	N/A	N/A	N/A	N/A	N/A	(1 kit of 8)	
60"x216"	(1 kit of 3)	(1 kit of 3)	N/A	N/A	N/A	N/A	N/A	(1 kit of 8)	
60"x240"	(1 kit of 3)	(1 kit of 3)	N/A	N/A	N/A	N/A	N/A	(1 kit of 8)	

STRUCTURE

Structure

Top-Base Compatibility Matrix

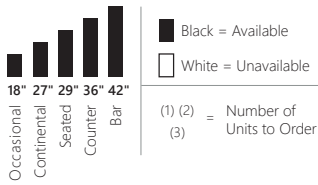

These top and base combinations are recommended and approved for optimal knee clearance, stability, and aesthetics. Required base and leg quantities are based on top size and shape. Please reference the Price and Specification Guide for more details.

TOP	AVAILABLE WIDTHS	MEDIUM ROUND PEDESTAL	LARGE ROUND PEDESTAL	MEDIUM SQUARE PEDESTAL	LARGE SQUARE PEDESTAL	MEDIUM X BASE	LARGE X BASE	SMALL CYLINDER	CYLINDER (W/M)	CYLINDER (NO W/M)	
RACETRACK	24"x36"	■ ■ ■ (1)	N/A	■ ■ ■ (1)	N/A	N/A	N/A	N/A	N/A	N/A	
	24"x42"	N/A	N/A	N/A	N/A	N/A	N/A	N/A	N/A	N/A	
	24"x48"	N/A	N/A	N/A	N/A	N/A	N/A	N/A	N/A	N/A	
	24"x60"	N/A	N/A	N/A	N/A	N/A	N/A	N/A	N/A	N/A	
	24"x72"	■ ■ ■ (2)	N/A	■ ■ ■ (2)	N/A	N/A	N/A	N/A	N/A	N/A	
	24"x84"	■ ■ ■ (2)	N/A	■ ■ ■ (2)	N/A	N/A	N/A	N/A	N/A	N/A	
	30"x42"	N/A	■ ■ ■ (1)	N/A	■ ■ ■ (1)	N/A	■ ■ ■ (1)	■ ■ ■ (1)	■ ■ ■ (1)	■ ■ ■ (1)	■ ■ ■ (1)
	30"x48"	N/A	■ ■ ■ (1)	N/A	■ ■ ■ (1)	N/A	■ ■ ■ (1)	■ ■ ■ (1)	N/A	■ ■ ■ (1)	■ ■ ■ (1)
	30"x60"	■ ■ ■ (2)	N/A	■ ■ ■ (2)	N/A	■ ■ ■ (2)	N/A	N/A	N/A	N/A	N/A
	30"x72"	■ ■ ■ (2)	N/A	■ ■ ■ (2)	N/A	■ ■ ■ (2)	N/A	N/A	N/A	N/A	N/A
	30"x84"	■ ■ ■ (2)	N/A	■ ■ ■ (2)	N/A	■ ■ ■ (2)	N/A	N/A	N/A	N/A	N/A
	36"x48"	N/A	■ ■ ■ (1)	N/A	■ ■ ■ (1)	N/A	■ ■ ■ (1)	■ ■ ■ (1)	■ ■ ■ (1)	■ ■ ■ (1)	■ ■ ■ (1)
	36"x60"	■ ■ ■ (2)	N/A	■ ■ ■ (2)	N/A	■ ■ ■ (2)	N/A	N/A	N/A	N/A	N/A
	36"x72"	■ ■ ■ (2)	N/A	■ ■ ■ (2)	N/A	■ ■ ■ (2)	N/A	N/A	■ ■ ■ (2)	■ ■ ■ (2)	■ ■ ■ (2)
	36"x84"	■ ■ ■ (2)	N/A	■ ■ ■ (2)	N/A	■ ■ ■ (2)	N/A	N/A	■ ■ ■ (2)	■ ■ ■ (1 kit of 2)	■ ■ ■ (1 kit of 2)
	36"x96"	■ ■ ■ (2)	N/A	■ ■ ■ (2)	N/A	■ ■ ■ (2)	N/A	N/A	■ ■ ■ (2)	■ ■ ■ (1 kit of 2)	■ ■ ■ (1 kit of 2)
	42"x72"	N/A	■ ■ ■ (2)	N/A	■ ■ ■ (2)	N/A	■ ■ ■ (2)	■ ■ ■ (2)	■ ■ ■ (2)	■ ■ ■ (2)	■ ■ ■ (2)
	42"x84"	N/A	■ ■ ■ (2)	N/A	■ ■ ■ (2)	N/A	■ ■ ■ (2)	■ ■ ■ (2)	■ ■ ■ (2)	■ ■ ■ (1 kit of 2)	■ ■ ■ (1 kit of 2)
	42"x96"	N/A	■ ■ ■ (2)	N/A	■ ■ ■ (2)	N/A	■ ■ ■ (2)	■ ■ ■ (2)	■ ■ ■ (2)	■ ■ ■ (1 kit of 2)	■ ■ ■ (1 kit of 2)
	42"x120"	N/A	■ ■ ■ (2)	N/A	■ ■ ■ (2)	N/A	■ ■ ■ (2)	■ ■ ■ (2)	■ ■ ■ (2)	■ ■ ■ (1 kit of 2)	■ ■ ■ (1 kit of 2)
	42"x144"	N/A	■ ■ ■ (3)	N/A	■ ■ ■ (3)	N/A	■ ■ ■ (3)	■ ■ ■ (3)	N/A	■ ■ ■ (1 kit of 2)	■ ■ ■ (1 kit of 2)
	48"x72"	N/A	■ ■ ■ (2)	N/A	■ ■ ■ (2)	N/A	■ ■ ■ (2)	■ ■ ■ (2)	N/A	■ ■ ■ (2)	■ ■ ■ (2)
	48"x84"	N/A	■ ■ ■ (2)	N/A	■ ■ ■ (2)	N/A	■ ■ ■ (2)	■ ■ ■ (2)	N/A	■ ■ ■ (1 kit of 2)	■ ■ ■ (1 kit of 2)
	48"x96"	N/A	■ ■ ■ (2)	N/A	■ ■ ■ (2)	N/A	■ ■ ■ (2)	■ ■ ■ (2)	N/A	■ ■ ■ (1 kit of 2)	■ ■ ■ (1 kit of 2)
	48"x120"	N/A	■ ■ ■ (2)	N/A	■ ■ ■ (2)	N/A	■ ■ ■ (2)	■ ■ ■ (2)	N/A	■ ■ ■ (1 kit of 2)	■ ■ ■ (1 kit of 2)
	48"x144"	N/A	■ ■ ■ (3)	N/A	■ ■ ■ (3)	N/A	■ ■ ■ (3)	■ ■ ■ (3)	N/A	■ ■ ■ (1 kit of 2)	■ ■ ■ (1 kit of 2)
	54"x96"	N/A	N/A	N/A	N/A	N/A	N/A	N/A	N/A	■ ■ ■ (1 kit of 2)	■ ■ ■ (1 kit of 2)
	54"x120"	N/A	N/A	N/A	N/A	N/A	N/A	N/A	N/A	■ ■ ■ (1 kit of 2)	■ ■ ■ (1 kit of 2)
	54"x144"	N/A	N/A	N/A	N/A	N/A	N/A	N/A	N/A	■ ■ ■ (1 kit of 2)	■ ■ ■ (1 kit of 2)
	54"x168"	N/A	N/A	N/A	N/A	N/A	N/A	N/A	N/A	■ ■ ■ (1 kit of 2)	■ ■ ■ (1 kit of 2)
54"x192"	N/A	N/A	N/A	N/A	N/A	N/A	N/A	N/A	■ ■ ■ (1 kit of 3)	■ ■ ■ (1 kit of 3)	
54"x216"	N/A	N/A	N/A	N/A	N/A	N/A	N/A	N/A	■ ■ ■ (1 kit of 3)	■ ■ ■ (1 kit of 3)	
54"x240"	N/A	N/A	N/A	N/A	N/A	N/A	N/A	N/A	■ ■ ■ (1 kit of 3)	■ ■ ■ (1 kit of 3)	
60"x120"	N/A	N/A	N/A	N/A	N/A	N/A	N/A	N/A	■ ■ ■ (1 kit of 2)	■ ■ ■ (1 kit of 2)	
60"x144"	N/A	N/A	N/A	N/A	N/A	N/A	N/A	N/A	■ ■ ■ (1 kit of 2)	■ ■ ■ (1 kit of 2)	
60"x168"	N/A	N/A	N/A	N/A	N/A	N/A	N/A	N/A	■ ■ ■ (1 kit of 2)	■ ■ ■ (1 kit of 2)	
60"x192"	N/A	N/A	N/A	N/A	N/A	N/A	N/A	N/A	■ ■ ■ (1 kit of 3)	■ ■ ■ (1 kit of 3)	
60"x216"	N/A	N/A	N/A	N/A	N/A	N/A	N/A	N/A	■ ■ ■ (1 kit of 3)	■ ■ ■ (1 kit of 3)	
60"x240"	N/A	N/A	N/A	N/A	N/A	N/A	N/A	N/A	■ ■ ■ (1 kit of 3)	■ ■ ■ (1 kit of 3)	

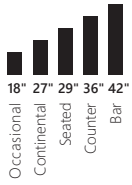

Black = Available
 White = Unavailable
 (1) (2) = Number of Units to Order
 (3) = Units to Order

These top and base combinations are recommended and approved for optimal knee clearance, stability, and aesthetics. Required base and leg quantities are based on top size and shape. Please reference the Price and Specification Guide for more details.

TOP	AVAILABLE WIDTHS	CUBE	PANEL	SMALL T LEGS	MEDIUM T LEGS	LARGE T LEGS	FIXED POST-LEGS	ADJUSTABLE POST-LEGS	COMMUNITY LEGS
RACETRACK	24"x36"	N/A	N/A	(1 kit of 2)	N/A	N/A	N/A	N/A	N/A
	24"x42"	N/A	N/A	(1 kit of 2)	N/A	N/A	N/A	N/A	N/A
	24"x48"	N/A	N/A	(1 kit of 2)	N/A	N/A	N/A	N/A	N/A
	24"x60"	N/A	N/A	(1 kit of 2)	N/A	N/A	N/A	N/A	N/A
	24"x72"	N/A	N/A	(1 kit of 2)	N/A	N/A	N/A	N/A	N/A
	24"x84"	N/A	N/A	(1 kit of 2)	N/A	N/A	N/A	N/A	N/A
	30"x42"	N/A	N/A	N/A	(1 kit of 2)	N/A	N/A	N/A	N/A
	30"x48"	N/A	N/A	N/A	(1 kit of 2)	N/A	N/A	N/A	N/A
	30"x60"	N/A	N/A	N/A	(1 kit of 2)	N/A	N/A	N/A	N/A
	30"x72"	N/A	N/A	N/A	(1 kit of 2)	N/A	N/A	N/A	N/A
	30"x84"	N/A	N/A	N/A	(1 kit of 2)	N/A	N/A	N/A	N/A
	36"x48"	N/A	N/A	N/A	(1 kit of 2)	N/A	N/A	N/A	(1 kit of 4)
	36"x60"	N/A	N/A	N/A	(1 kit of 2)	N/A	N/A	N/A	(1 kit of 4)
	36"x72"	N/A	(2)	N/A	(1 kit of 2)	N/A	N/A	N/A	(1 kit of 4)
	36"x84"	N/A	(1 kit of 2)	N/A	(1 kit of 2)	N/A	N/A	N/A	(1 kit of 4)
	36"x96"	N/A	(1 kit of 2)	N/A	(1 kit of 2)	N/A	N/A	N/A	(1 kit of 4)
	42"x72"	N/A	(2)	N/A	N/A	(1 kit of 2)	N/A	N/A	(1 kit of 4)
	42"x84"	N/A	(1 kit of 2)	N/A	N/A	(1 kit of 2)	N/A	N/A	(1 kit of 4)
	42"x96"	N/A	(1 kit of 2)	N/A	N/A	(1 kit of 2)	N/A	N/A	(1 kit of 4)
	42"x120"	N/A	(1 kit of 2)	N/A	N/A	N/A	N/A	N/A	(1 kit of 6)
	42"x144"	(1 kit of 2)	(1 kit of 2)	N/A	N/A	N/A	N/A	N/A	(1 kit of 6)
	48"x72"	(2)	(2)	N/A	N/A	N/A	N/A	N/A	(1 kit of 4)
	48"x84"	(1 kit of 2)	(1 kit of 2)	N/A	N/A	N/A	N/A	N/A	(1 kit of 4)
	48"x96"	(1 kit of 2)	(1 kit of 2)	N/A	N/A	N/A	N/A	N/A	(1 kit of 4)
	48"x120"	(1 kit of 2)	(1 kit of 2)	N/A	N/A	N/A	N/A	N/A	(1 kit of 6)
	48"x144"	(1 kit of 2)	(1 kit of 2)	N/A	N/A	N/A	N/A	N/A	(1 kit of 6)
	54"x96"	(1 kit of 2)	(1 kit of 2)	N/A	N/A	N/A	N/A	N/A	(1 kit of 4)
	54"x120"	(1 kit of 2)	(1 kit of 2)	N/A	N/A	N/A	N/A	N/A	(1 kit of 6)
54"x144"	(1 kit of 2)	(1 kit of 2)	N/A	N/A	N/A	N/A	N/A	(1 kit of 6)	
54"x168"	(1 kit of 2)	(1 kit of 3)	N/A	N/A	N/A	N/A	N/A	(1 kit of 6)	
54"x192"	(1 kit of 3)	(1 kit of 3)	N/A	N/A	N/A	N/A	N/A	(1 kit of 8)	
54"x216"	(1 kit of 3)	(1 kit of 3)	N/A	N/A	N/A	N/A	N/A	(1 kit of 8)	
54"x240"	(1 kit of 3)	(1 kit of 3)	N/A	N/A	N/A	N/A	N/A	(1 kit of 8)	
60"x120"	(1 kit of 2)	(1 kit of 2)	N/A	N/A	N/A	N/A	N/A	(1 kit of 6)	
60"x144"	(1 kit of 2)	(1 kit of 3)	N/A	N/A	N/A	N/A	N/A	(1 kit of 6)	
60"x168"	(1 kit of 2)	(1 kit of 3)	N/A	N/A	N/A	N/A	N/A	(1 kit of 6)	
60"x192"	(1 kit of 3)	(1 kit of 3)	N/A	N/A	N/A	N/A	N/A	(1 kit of 8)	
60"x216"	(1 kit of 3)	(1 kit of 3)	N/A	N/A	N/A	N/A	N/A	(1 kit of 8)	
60"x240"	(1 kit of 3)	(1 kit of 3)	N/A	N/A	N/A	N/A	N/A	(1 kit of 8)	

STRUCTURE

- Order Base Separately.
- Order power units separately.
- Tops ship with pilot holes for locating supports.
- Reference page 511 for cutout locations.
- Middle seams on multi-piece tops are not edgebanded.
- External stiffeners are included with top models when required.
- Available in laminate (flat or knife edges).
- For 72" to 84" tops, the woodgrain direction runs parallel with the seam and will have greater alignment variations.

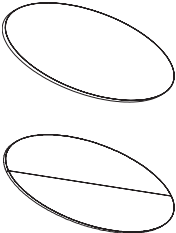

Description	Model	Cutout	Ship Weight	Cubes	List Price		
					L1	L2	L3
Round Tops Laminate Square Edge							
24" Diameter	AMPTLFPO24RND	G1	20.0	1.6	\$ 426	\$ 442	\$ 457
30" Diameter	AMPTLFPO30RND	G1	28.0	2.4	\$ 509	\$ 528	\$ 546
36" Diameter	AMPTLFPO36RND	G1	38.0	3.6	\$ 631	\$ 654	\$ 676
42" Diameter	AMPTLFPO42RND	G1	50.0	4.9	\$ 745	\$ 772	\$ 799
48" Diameter	AMPTLFPO48RND	G1	64.0	5.8	\$ 907	\$ 939	\$ 972
54" Diameter	AMPTLF54RND	C1	80.0	7.5	\$ 1312	\$ 1359	\$ 1405
60" Diameter	AMPTLF60RND	C1	113.6	9.3	\$ 1512	\$ 1566	\$ 1619
72" Diameter (2 pieces)	AMPTLF72RND	C2	161.8	7.2	\$ 2084	\$ 2159	\$ 2231
84" Diameter (2 pieces)	AMPTLF84RND	C2	213.0	9.5	\$ 2656	\$ 2751	\$ 2843
Round Tops Laminate Knife Edge							
24" Diameter	AMPTLKPO24RND	G1	20.0	1.6	\$ 891	\$ 923	\$ 955
30" Diameter	AMPTLKPO30RND	G1	28.0	2.4	\$ 1119	\$ 1160	\$ 1199
36" Diameter	AMPTLKPO36RND	G1	38.0	3.6	\$ 1388	\$ 1437	\$ 1486
42" Diameter	AMPTLKPO42RND	G1	50.0	4.9	\$ 1641	\$ 1699	\$ 1757
48" Diameter	AMPTLKPO48RND	G1	64.0	5.8	\$ 1993	\$ 2064	\$ 2134
54" Diameter	AMPTLK54RND	C1	80.0	7.5	\$ 2893	\$ 2995	\$ 3096
60" Diameter	AMPTLK60RND	C1	113.6	9.3	\$ 3322	\$ 3440	\$ 3555
72" Diameter (2 pieces)	AMPTLK72RND	C2	161.8	7.2	\$ 4576	\$ 4736	\$ 4896
84" Diameter (2 pieces)	AMPTLK84RND	C2	213.0	9.5	\$ 5848	\$ 6053	\$ 6257

STRUCTURE

How to specify — Select the Model Number from above.	1st Option: FSC Certified Wood: FSC Enter for FSC wood X Enter for non-FSC wood	2nd Option: Laminate: See page 508 for finishes.	3rd Option: Edge: See page 508 for finishes.	4th Option: Cutout (if applicable): Upcharge of \$18 per cutout. C0 No cutout C1 Large center cutout C2 Two large center cutouts G1 One small center cutout
AMP T L 	C

Examples: AMPTLK36RND.X.LTI1.LM13.C1 AMPTLF64RND.FSC.LLA1.LWNW.C0

- Order Base Separately.
- Order power units separately.
- Tops ship with pilot holes for locating supports.
- Reference page [511](#) for cutout locations.
- External stiffeners are included with top models when required.
- Available in laminate (flat or knife edges).
- Grommet cutout G1 cannot be specified with pedestal or X-base.

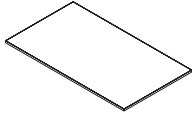

Description	Model	Cutout	Ship Weight	Cubes	List Price		
					L1	L2	L3
Rectangle Tops Laminate Square Edge							
24" x 36" Rectangle	AMPTLF2436RE	G1 ATE	31.0	2.7	\$ 474	\$ 492	\$ 508
24" x 42" Rectangle	AMPTLF2442RE	G1 ATE	36.0	3.1	\$ 508	\$ 527	\$ 545
24" x 48" Rectangle	AMPTLF2448RE	G1 ATE	41.0	3.5	\$ 542	\$ 562	\$ 582
24" x 60" Rectangle	AMPTLF2460RE	C1 ATE	66.6	6.1	\$ 647	\$ 670	\$ 693
24" x 72" Rectangle	AMPTLF2472RE	C1 ATE	79.8	6.8	\$ 723	\$ 750	\$ 775
24" x 84" Rectangle	AMPTLF2484RE	C1 ATE	93.0	8.8	\$ 855	\$ 886	\$ 916
30" x 42" Rectangle	AMPTLF3042RE	G1 ATE	46.0	3.7	\$ 536	\$ 556	\$ 576
30" x 48" Rectangle	AMPTLF3048RE	G1 ATE	52.0	4.2	\$ 582	\$ 603	\$ 624
30" x 60" Rectangle	AMPTLF3060RE	C1 ATE	79.6	7.0	\$ 738	\$ 765	\$ 791
30" x 72" Rectangle	AMPTLF3072RE	C1 ATE	94.8	7.9	\$ 826	\$ 856	\$ 885
30" x 84" Rectangle	AMPTLF3084RE	C1 ATE	110.0	10.1	\$ 997	\$ 1033	\$ 1068
36" x 48" Rectangle	AMPTLF3648RE	G1	61.0	4.9	\$ 660	\$ 684	\$ 707
36" x 60" Rectangle	AMPTLF3660RE	C1	91.6	7.8	\$ 800	\$ 829	\$ 857
36" x 72" Rectangle	AMPTLF3672RE	C1	108.8	9.0	\$ 941	\$ 974	\$ 1008
36" x 84" Rectangle	AMPTLF3684RE	C1	126.0	11.3	\$ 1186	\$ 1229	\$ 1270
36" x 96" Rectangle	AMPTLF3696RE	C1	143.2	12.4	\$ 1386	\$ 1435	\$ 1483
42" x 60" Rectangle	AMPTLF4260RE	C1	103.6	8.7	\$ 1124	\$ 1165	\$ 1204
42" x 72" Rectangle	AMPTLF4272RE	C1	122.8	10.0	\$ 1236	\$ 1281	\$ 1323
42" x 84" Rectangle	AMPTLF4284RE	C1	143.0	12.5	\$ 1402	\$ 1452	\$ 1501
42" x 96" Rectangle	AMPTLF4296RE	C1	162.2	13.8	\$ 1468	\$ 1521	\$ 1573
48" x 72" Rectangle	AMPTLF4872RE	C1	136.8	11.1	\$ 1337	\$ 1385	\$ 1431
48" x 84" Rectangle	AMPTLF4884RE	C1	159.0	13.8	\$ 1593	\$ 1650	\$ 1706
48" x 96" Rectangle	AMPTLF4896RE	C1	181.2	15.2	\$ 1666	\$ 1725	\$ 1784
54" x 96" Rectangle	AMPTLF5496RE	C1	199.2	16.6	\$ 1864	\$ 1930	\$ 1995

STRUCTURE

<p>How to specify — Select the Model Number from above.</p>	<p><i>1st Option:</i> FSC Certified Wood: FSC Enter for FSC wood X Enter for non-FSC wood</p>	<p><i>2nd Option:</i> Laminate: See page 508 for finishes.</p>	<p><i>3rd Option:</i> Edge: See page 508 for finishes.</p>	<p><i>4th Option:</i> Cutout (if applicable): Upcharge of \$18 per cutout. C0 No cutout C1 Large center cutout G1 One small center cutout ATE One small edge cutout</p>
<p>AMPT L . </p>	<p> . </p>	<p> . </p>	<p> . </p>	<p> . </p>

Example: AMPTLF2436RE.X.LT11.LM13.C1

Structure

Rectangle Tops

- Order Base Separately.
- Order power units separately.
- Tops ship with pilot holes for locating supports.
- Reference page 511 for cutout locations.
- External stiffeners are included with top models when required.
- Available in laminate (flat or knife edges).
- Grommet cutout G1 cannot be specified with pedestal or X-base.

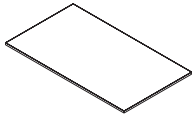

Description	Model	Cutout	Ship Weight	Cubes	List Price			
					L1	L2	L3	
Rectangle Tops Laminate Knife Edge								
24" x 36" Rectangle	AMPTLK2436RE	G1 ATE	31.0	2.7	\$ 1044	\$ 1082	\$ 1118	
24" x 42" Rectangle	AMPTLK2442RE	G1 ATE	36.0	3.1	\$ 1117	\$ 1158	\$ 1197	
24" x 48" Rectangle	AMPTLK2448RE	G1 ATE	41.0	3.5	\$ 1195	\$ 1238	\$ 1280	
24" x 60" Rectangle	AMPTLK2460RE	C1 ATE	66.6	6.1	\$ 1426	\$ 1476	\$ 1527	
24" x 72" Rectangle	AMPTLK2472RE	C1 ATE	79.8	6.8	\$ 1590	\$ 1647	\$ 1702	
24" x 84" Rectangle	AMPTLK2484RE	C1 ATE	93.0	8.8	\$ 1885	\$ 1952	\$ 2018	
30" x 42" Rectangle	AMPTLK3042RE	G1 ATE	46.0	3.7	\$ 1181	\$ 1224	\$ 1265	
30" x 48" Rectangle	AMPTLK3048RE	G1 ATE	52.0	4.2	\$ 1282	\$ 1328	\$ 1373	
30" x 60" Rectangle	AMPTLK3060RE	C1 ATE	79.6	7.0	\$ 1623	\$ 1681	\$ 1738	
30" x 72" Rectangle	AMPTLK3072RE	C1 ATE	94.8	7.9	\$ 1821	\$ 1886	\$ 1950	
30" x 84" Rectangle	AMPTLK3084RE	C1 ATE	110.0	10.1	\$ 2198	\$ 2277	\$ 2353	
36" x 48" Rectangle	AMPTLK3648RE	G1	61.0	4.9	\$ 1452	\$ 1504	\$ 1555	
36" x 60" Rectangle	AMPTLK3660RE	C1	91.6	7.8	\$ 1990	\$ 2061	\$ 2131	
36" x 72" Rectangle	AMPTLK3672RE	C1	108.8	9.0	\$ 2226	\$ 2305	\$ 2383	
36" x 84" Rectangle	AMPTLK3684RE	C1	126.0	11.3	\$ 2936	\$ 3041	\$ 3142	
36" x 96" Rectangle	AMPTLK3696RE	C1	143.2	12.4	\$ 3048	\$ 3156	\$ 3263	
42" x 60" Rectangle	AMPTLK4260RE	C1	103.6	8.7	\$ 2473	\$ 2560	\$ 2647	
42" x 72" Rectangle	AMPTLK4272RE	C1	122.8	10.0	\$ 2721	\$ 2817	\$ 2913	
42" x 84" Rectangle	AMPTLK4284RE	C1	143.0	12.5	\$ 3081	\$ 3190	\$ 3298	
42" x 96" Rectangle	AMPTLK4296RE	C1	162.2	13.8	\$ 3232	\$ 3347	\$ 3460	
48" x 72" Rectangle	AMPTLK4872RE	C1	136.8	11.1	\$ 3154	\$ 3265	\$ 3376	
48" x 84" Rectangle	AMPTLK4884RE	C1	159.0	13.8	\$ 3512	\$ 3636	\$ 3759	
48" x 96" Rectangle	AMPTLK4896RE	C1	181.2	15.2	\$ 3667	\$ 3796	\$ 3925	
54" x 96" Rectangle	AMPTLK5496RE	C1	199.2	16.6	\$ 4099	\$ 4244	\$ 4388	

STRUCTURE

How to specify — Select the Model Number from above.	1st Option: FSC Certified Wood: FSC Enter for FSC wood X Enter for non-FSC wood	2nd Option: Laminate: See page 508 for finishes.	3rd Option: Edge: See page 508 for finishes.	4th Option: Cutout (if applicable): Upcharge of \$18 per cutout. C0 No cutout C1 Large center cutout G1 One small center cutout ATE One small edge cutout
AMPTL 				

Example: AMPTLK2436RE.X.LT11.LM13.C1

- Order Base Separately.
- Order power units separately.
- Tops ship with pilot holes for locating supports.
- Reference page 511 for cutout locations.
- Middle seams on multi-piece tops are not edgebanded.
- External stiffeners are included with top models when required.
- Available in laminate (flat or knife edges).
- 192" to 240" tops are 3 pieces.
- 60"D tops may have greater woodgrain alignment variation across the seams.

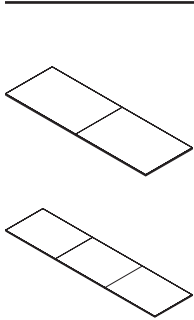

Description	Model	Cutout	Ship Weight	Cubes	List Price		
					L1	L2	L3
Rectangle Multi-Piece Tops Laminate Square Edge (model number indicates two or three units)							
36" x 120" Rectangle	AMPTLF36120RE	C2	178.2	18.1	\$ 2030	\$ 2102	\$ 2174
36" x 144" Rectangle	AMPTLF36144RE	C2	206.2	20.9	\$ 2274	\$ 2355	\$ 2434
42" x 120" Rectangle	AMPTLF42120RE	C2	192.2	20.4	\$ 2255	\$ 2335	\$ 2414
42" x 144" Rectangle	AMPTLF42144RE	C2	224.2	23.6	\$ 2528	\$ 2618	\$ 2707
48" x 120" Rectangle	AMPTLF48120RE	C2	216.2	22.6	\$ 2255	\$ 2335	\$ 2414
48" x 144" Rectangle	AMPTLF48144RE	C2	252.2	26.2	\$ 2528	\$ 2618	\$ 2707
54" x 120" Rectangle	AMPTLF54120RE	C2	238.2	24.8	\$ 2814	\$ 2913	\$ 3012
54" x 144" Rectangle	AMPTLF54144RE	C2	280.2	28.9	\$ 3157	\$ 3269	\$ 3379
54" x 168" Rectangle	AMPTLF54168RE	C2	322.2	33.0	\$ 3892	\$ 4028	\$ 4165
54" x 192" Rectangle	AMPTLF54192RE	C3	378.2	44.8	\$ 4689	\$ 4854	\$ 5019
54" x 216" Rectangle	AMPTLF54216RE	C3	420.2	44.8	\$ 5037	\$ 5215	\$ 5391
54" x 240" Rectangle	AMPTLF54240RE	C3	462.2	50.9	\$ 5878	\$ 6081	\$ 6283
60" x 120" Rectangle	AMPTLF60120RE	C2	262.2	27.1	\$ 2952	\$ 3057	\$ 3160
60" x 144" Rectangle	AMPTLF60144RE	C2	308.2	31.6	\$ 3316	\$ 3433	\$ 3549
60" x 168" Rectangle	AMPTLF60168RE	C2	356.2	36.0	\$ 4084	\$ 4228	\$ 4371
60" x 192" Rectangle	AMPTLF60192RE	C3	416.2	48.8	\$ 4924	\$ 5098	\$ 5270
60" x 216" Rectangle	AMPTLF60216RE	C3	462.2	48.8	\$ 5289	\$ 5475	\$ 5660
60" x 240" Rectangle	AMPTLF60240RE	C3	510.2	55.6	\$ 6168	\$ 6382	\$ 6594

Rectangle Multi-Piece Tops Laminate Knife Edge (model number indicates two or three units)							
36" x 120" Rectangle	AMPTLK36120RE	C2	178.2	18.1	\$ 3180	\$ 3292	\$ 3403
36" x 144" Rectangle	AMPTLK36144RE	C2	206.2	20.9	\$ 3482	\$ 3605	\$ 3727
42" x 120" Rectangle	AMPTLK42120RE	C2	192.2	20.4	\$ 3532	\$ 3656	\$ 3780
42" x 144" Rectangle	AMPTLK42144RE	C2	224.2	23.6	\$ 3868	\$ 4004	\$ 4139
48" x 120" Rectangle	AMPTLK48120RE	C2	216.2	22.6	\$ 3532	\$ 3656	\$ 3780
48" x 144" Rectangle	AMPTLK48144RE	C2	252.2	26.2	\$ 3868	\$ 4004	\$ 4139
54" x 120" Rectangle	AMPTLK54120RE	C2	238.2	24.8	\$ 4412	\$ 4568	\$ 4721
54" x 144" Rectangle	AMPTLK54144RE	C2	280.2	28.9	\$ 4829	\$ 4999	\$ 5168
54" x 168" Rectangle	AMPTLK54168RE	C2	322.2	33.0	\$ 6261	\$ 6481	\$ 6701
54" x 192" Rectangle	AMPTLK54192RE	C3	378.2	44.8	\$ 7742	\$ 8013	\$ 8285
54" x 216" Rectangle	AMPTLK54216RE	C3	420.2	44.8	\$ 8159	\$ 8445	\$ 8731
54" x 240" Rectangle	AMPTLK54240RE	C3	462.2	50.9	\$ 9703	\$10039	\$10375
60" x 120" Rectangle	AMPTLK60120RE	C2	262.2	27.1	\$ 4631	\$ 4793	\$ 4957
60" x 144" Rectangle	AMPTLK60144RE	C2	308.2	31.6	\$ 5070	\$ 5249	\$ 5426
60" x 168" Rectangle	AMPTLK60168RE	C2	356.2	36.0	\$ 6573	\$ 6804	\$ 7034
60" x 192" Rectangle	AMPTLK60192RE	C3	416.2	48.8	\$ 8128	\$ 8414	\$ 8698
60" x 216" Rectangle	AMPTLK60216RE	C3	462.2	48.8	\$ 8566	\$ 8867	\$ 9167
60" x 240" Rectangle	AMPTLK60240RE	C3	510.2	55.6	\$10181	\$10535	\$10887

<p>How to specify —</p> <p>Select the Model Number from above.</p>	<p><i>1st Option:</i></p> <p>FSC Certified Wood:</p> <p>FSC Enter for FSC wood X Enter for non-FSC wood</p>	<p><i>2nd Option:</i></p> <p>Laminate:</p> <p>See page 508 for finishes.</p>	<p><i>3rd Option:</i></p> <p>Edge:</p> <p>See page 508 for finishes.</p>	<p><i>4th Option:</i></p> <p>Cutout (if applicable):</p> <p>Upcharge of \$18 per cutout.</p> <p>C0 No cutout C2 Two large center cutouts C3 Three large center cutouts</p>
---	--	---	---	---

AMPT|L C

Examples: AMPTLK36120RE.X.LT11.LM13.C2 AMPTLF36120RE.FSC.LLA1.LWNW.C0

- Wall Mount Bracket is used to fasten one end of a table top to the wall. User to provide mounting hardware.
- Order Base Separately.
- Order power units separately.
- Tops ship with pilot holes for locating supports.
- Reference page 511 for cutout locations.
- External stiffeners are included with top models when required.
- Available in laminate (flat or knife edges).

Description	Model	Ship Weight	Cubes	List Price		
				P1	P2	P3
Accessories						
Wall Mount Bracket	AMPTWMB	4.0	0.4	\$ 157	N/A	N/A
Tilt Wall Mount for 32" to 70" TVs or Monitors						
26 1/8" W x 17 3/8" H; -10° -0° Tilt	GATVMB			\$ 554		
Includes mounting hardware and conforms to VESA-compliant displays. Supports up to 165 lbs.						

Description	Model	Cutout	Ship Weight	Cubes	List Price		
					L1	L2	L3
Media Rectangle Tops Laminate Square Edge							
48" x 54" Media Rectangle	AMPTLF4854MRE	C1	89.0	7.1	\$ 1322	\$ 1369	\$ 1416
48" x 60" Media Rectangle	AMPTLF4860MRE	C1	115.6	9.6	\$ 1441	\$ 1493	\$ 1543
54" x 54" Media Rectangle	AMPTLF5454MRE	C1	110	8.7	\$ 1882	\$ 1949	\$ 2015
54" x 60" Media Rectangle	AMPTLF5460MRE	C1	126.6	10.5	\$ 2033	\$ 2105	\$ 2177
54" x 72" Media Rectangle	AMPTLF5472MRE	C1	150.8	12.2	\$ 2229	\$ 2308	\$ 2386
60" x 60" Media Rectangle	AMPTLF6060MRE	C1	159.8	13.2	\$ 2206	\$ 2281	\$ 2355
60" x 72" Media Rectangle	AMPTLF6072MRE	C1	159.8	13.2	\$ 2233	\$ 2313	\$ 2390
Media Rectangle Tops Laminate Knife Edge							
48" x 54" Media Rectangle	AMPTLK4854MRE	C1	89.0	7.1	\$ 1986	\$ 2057	\$ 2127
48" x 60" Media Rectangle	AMPTLK4860MRE	C1	115.6	9.6	\$ 2164	\$ 2242	\$ 2317
54" x 54" Media Rectangle	AMPTLK5454MRE	C1	110	8.7	\$ 2827	\$ 2926	\$ 3025
54" x 60" Media Rectangle	AMPTLK5460MRE	C1	126.6	10.5	\$ 3047	\$ 3155	\$ 3262
54" x 72" Media Rectangle	AMPTLK5472MRE	C1	150.8	12.2	\$ 3342	\$ 3460	\$ 3576
60" x 60" Media Rectangle	AMPTLK6060MRE	C1	159.8	13.2	\$ 3135	\$ 3247	\$ 3359
60" x 72" Media Rectangle	AMPTLK6072MRE	C1	159.8	13.2	\$ 3348	\$ 3466	\$ 3583

<p>How to specify — Select the Model Number from above.</p>	<p>1st Option: FSC Certified Wood: FSC Enter for FSC wood X Enter for non-FSC wood</p>	<p>2nd Option: Laminate: See page 508 for finishes.</p>	<p>3rd Option: Edge: See page 508 for finishes.</p>	<p>4th Option: Cutout (if applicable): Upcharge of \$18 per cutout. C0 No cutout C1 Large center cutout</p>
AMPTL				C

Examples: AMPTLK4854MRE.X.LT11.LM13.C1 AMPTLF4854MRE.FSC.LLA1.LWNW.CO

- External support stiffeners that ship with tops will not be used with panel base models that include beams.
- Removable end caps allow access to route power and data wires from the floor to undersurface.
- See page 513 for wire routing capacity from floor to undersurface.
- Panel base glides provide 3/4" adjustment.
- Power modules are ordered separately.
- 72" W top requires 2 single bases
- For tables 120" or greater, a set of beams is provided.



Description	Model	Ship Weight	Cubes	List Price		
				L1	L2	L3
Hollow Panel Bases — Laminate						
Single	AMPTPL	58.0	5.2	\$ 1718	\$ 1778	\$ 1839
for 84" Wide	AMPTPL84	125.0	10.9	\$ 3800	\$ 3920	\$ 4042
for 96" Wide	AMPTPL96	125.0	10.9	\$ 3800	\$ 3920	\$ 4042
for 120" Wide	AMPTPL120	131.0	11.2	\$ 3927	\$ 4047	\$ 4169
for 144" Wide	AMPTPL144	133.0	11.4	\$ 4058	\$ 4178	\$ 4300
for 168" Wide	AMPTPL168	135.0	16.9	\$ 5933	\$ 6113	\$ 6294
for 192" Wide	AMPTPL192	202.0	17.1	\$ 6107	\$ 6287	\$ 6468
for 216" Wide	AMPTPL216	204.0	17.3	\$ 6238	\$ 6418	\$ 6599
for 240" Wide	AMPTPL240	206.0	17.6	\$ 6395	\$ 6575	\$ 6756

<p>How to specify — Select the Model Number from above.</p>	<p>1st Option: FSC Certified Wood: FSC Enter for FSC wood X Enter for non-FSC wood</p>	<p>2nd Option: Laminate: See page 508 for finishes.</p>	<p>3rd Option: Endcap: See page 508 for finishes.</p>
<p>AMPTPL</p>	<p>.</p>	<p>.</p>	<p>.</p>

Example: AMPTPL120.X.LT11.LM16

- Removable end cap on seated height cube allows access to route power and data wires from the floor to undersurface.
- Hinged door on standing height cube allows access to route power and data wires from the floor to undersurface.
- See page 513 for wire routing capacity from floor to undersurface.
- Power modules are ordered separately.
- For tables 120" or greater a set of beams are supplied.
- External support stiffeners that ship with tops will not be used with panel base models that include beams.
- Integrated wire management is offered.
- Cube base requires 150 lbs. of sand or other ballast material per base for stability (supplied by customer).
- 72" W top requires 2 single bases.



Description	Model	Ship Weight	Cubes	List Price		
				L1	L2	L3
Cube Seated Bases — Laminate						
Single	AMPTCB	65.0	9.1	\$ 2116	\$ 2191	\$ 2265
for 84" Wide	AMPTCB84	130.0	18.2	\$ 4232	\$ 4381	\$ 4529
for 96" Wide	AMPTCB96	130.0	18.2	\$ 4232	\$ 4381	\$ 4529
for 120" Wide	AMPTCB120	145.0	19.0	\$ 4723	\$ 4872	\$ 5020
for 144" Wide	AMPTCB144	147.0	19.2	\$ 4854	\$ 5003	\$ 5151
for 168" Wide	AMPTCB168	149.0	19.5	\$ 5011	\$ 5160	\$ 5308
for 192" Wide	AMPTCB192	223.0	28.8	\$ 7301	\$ 7524	\$ 7746
for 216" Wide	AMPTCB216	225.0	29.0	\$ 7432	\$ 7655	\$ 7877
for 240" Wide	AMPTCB240	227.0	29.3	\$ 7589	\$ 7812	\$ 8034

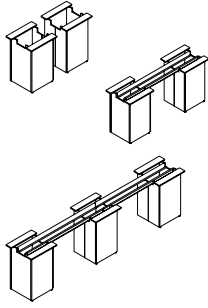

Description	Model	Ship Weight	Cubes	List Price		
				L1	L2	L3
Cube Standing Bases — Laminate						
Single	AMPTCBST	95.0	16.3	\$ 2659	\$ 2753	\$ 2846
for 84" Wide	AMPTCBST84	180.0	32.6	\$ 5318	\$ 5505	\$ 5691
for 96" Wide	AMPTCBST96	180.0	32.6	\$ 5318	\$ 5505	\$ 5691
for 120" Wide	AMPTCBST120	195.0	33.4	\$ 5809	\$ 5996	\$ 6182
for 144" Wide	AMPTCBST144	197.0	33.6	\$ 5940	\$ 6127	\$ 6313
for 168" Wide	AMPTCBST168	199.0	33.9	\$ 6097	\$ 6284	\$ 6470
for 192" Wide	AMPTCBST192	298.0	50.4	\$ 8930	\$ 9211	\$ 9490
for 216" Wide	AMPTCBST216	300.0	50.6	\$ 9061	\$ 9342	\$ 9621
for 240" Wide	AMPTCBST240	302.0	50.9	\$ 9218	\$ 9499	\$ 9778

<p>How to specify — Select the Model Number from above.</p>	<p>1st Option: FSC Certified Wood: FSC Enter for FSC wood X Enter for non-FSC wood</p>	<p>2nd Option: Laminate: See page 508 for finishes.</p>
AMPTCB	X	

Examples: AMPTCB120.X.LM13EY AMPTCBST240.FSC.SC777

- X-table bases are available with painted or polished aluminum finishes.
- Polished aluminum bases feature a painted vertical column.
- X-base glides provide ½" adjustment.
- Medium X-table bases are available with casters and glides.
- All casters are locking with urethane tread.
- X-base glides offer ½" of adjustment.
- Some assembly required.

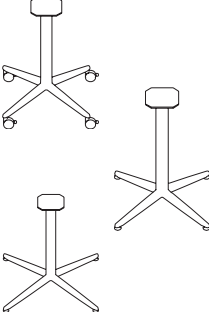

Description	Model	Ship Weight	Cubes	List Price		
				P1	P2	P3
Medium X Bases						
Medium Occasional Height w/Casters	AMPTXM18C	15.0	0.2	\$ 670	\$ 694	\$ 718
Medium Occasional Height w/Glides	AMPTXM18G	15.0	0.2	\$ 670	\$ 694	\$ 718
Medium Continental Height w/Casters	AMPTXM26C	15.0	0.2	\$ 717	\$ 742	\$ 769
Medium Continental Height w/Glides	AMPTXM26G	15.0	0.2	\$ 717	\$ 742	\$ 769
Medium Seated Height w/Casters	AMPTXM29C	15.0	0.2	\$ 721	\$ 748	\$ 773
Medium Seated Height w/Glides	AMPTXM29G	15.0	0.2	\$ 721	\$ 748	\$ 773
Medium Counter Height w/Glides	AMPTXM36G	15.0	0.2	\$ 856	\$ 886	\$ 915
Medium Bar Height w/Glides	AMPTXM42G	15.0	0.2	\$ 882	\$ 913	\$ 942
Large Occasional Height w/Glides	AMPTXL18G	18.0	0.1	\$ 910	\$ 942	\$ 975
Large Continental Height w/Glides	AMPTXL26G	18.0	0.1	\$ 956	\$ 990	\$ 1024
Large Seated Height w/Glides	AMPTXL29G	18.0	0.1	\$ 965	\$ 999	\$ 1033

Medium X Bases — Polished

Medium Occasional Height w/Casters	AMPTXM18CP	15.0	0.2	\$ 804	\$ 828	\$ 852
Medium Occasional Height w/Glides	AMPTXM18GP	15.0	0.2	\$ 804	\$ 828	\$ 852
Medium Continental Height w/Casters	AMPTXM26CP	15.0	0.2	\$ 853	\$ 878	\$ 905
Medium Continental Height w/Glides	AMPTXM26GP	15.0	0.2	\$ 853	\$ 878	\$ 905
Medium Seated Height w/Casters	AMPTXM29CP	15.0	0.2	\$ 856	\$ 883	\$ 908
Medium Seated Height w/Glides	AMPTXM29GP	15.0	0.2	\$ 856	\$ 883	\$ 908
Medium Counter Height w/Glides	AMPTXM36GP	15.0	0.2	\$ 963	\$ 993	\$ 1022
Medium Bar Height w/Glides	AMPTXM42GP	15.0	0.2	\$ 988	\$ 1019	\$ 1048
Large Occasional Height w/Glides	AMPTXL18GP	18.0	0.1	\$ 1043	\$ 1075	\$ 1108
Large Continental Height w/Glides	AMPTXL26GP	18.0	0.1	\$ 1092	\$ 1126	\$ 1160
Large Seated Height w/Glides	AMPTXL29GP	18.0	0.1	\$ 1101	\$ 1135	\$ 1169

<p>How to specify — Select the Model Number from above.</p> <p>AMPTX . .</p>	<p>1st Option: Paint: Finish P1 P2 P3 See page 508 for finishes.</p>	<p>2nd Option: Paint Finish for column on PAL Bases: P1 P2 P3 See page 508 for finishes.</p>
--	--	--

Examples: AMPTXM18C.P27.P27 AMPTXL18G.P27.P27 AMPTXM18CP.P27.P27 AMPTXL18GP.P27.P27

- ¼" tall, non-adjustable, slide glides on all bases.
- Some assembly required.

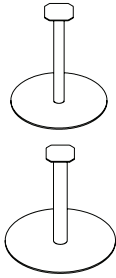

Description	Model	Ship Weight	Cubes	List Price	
				P1	P2
Round Pedestal Bases					
Medium Occasional Height	AMTPR18M	60.0	4.0	\$ 902	\$ 934
Medium Continental Height	AMTPR26M	60.0	4.0	\$ 925	\$ 957
Medium Seated Height	AMTPR29M	60.0	4.0	\$ 929	\$ 961
Medium Counter Height	AMTPR36M	62.0	4.6	\$ 1067	\$ 1105
Medium Bar Height	AMTPR42M	66.0	5.1	\$ 1096	\$ 1134
Large Occasional Height	AMTPR18L	95.0	4.5	\$ 1285	\$ 1330
Large Continental Height	AMTPR26L	95.0	4.5	\$ 1307	\$ 1352
Large Seated Height	AMTPR29L	95.0	4.5	\$ 1313	\$ 1358
Large Counter Height	AMTPR36L	98.0	5.1	\$ 1451	\$ 1501
Large Bar Height	AMTPR42L	101.0	5.6	\$ 1477	\$ 1527

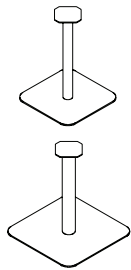

Square Pedestal Bases					
Medium Occasional Height	AMTPS18M	60.0	3.6	\$ 1011	\$ 1043
Medium Continental Height	AMTPS26M	60.0	3.6	\$ 1034	\$ 1066
Medium Seated Height	AMTPS29M	60.0	3.6	\$ 1038	\$ 1070
Medium Counter Height	AMTPS36M	62.0	4.2	\$ 1176	\$ 1214
Medium Bar Height	AMTPS42M	66.0	4.7	\$ 1205	\$ 1243
Large Occasional Height	AMTPS18L	95.0	4.2	\$ 1335	\$ 1380
Large Continental Height	AMTPS26L	95.0	4.2	\$ 1357	\$ 1402
Large Seated Height	AMTPS29L	95.0	4.2	\$ 1363	\$ 1408
Large Counter Height	AMTPS36L	98.0	4.8	\$ 1501	\$ 1551
Large Bar Height	AMTPS42L	101.0	5.3	\$ 1527	\$ 1577

STRUCTURE

How to specify —
Select the Model Number from above.

1st Option:
Paint Finishes:
P1
P2
 See page 508 for finishes.

AMPT|P| | | | | | | | | | | . | | | | | | |

Examples: AMTPR18M.P27 AMTPS18L.P27

Structure

T-Leg / Post-Leg / Community Bases

- T-leg table bases are available in painted or polished aluminum.
- T-leg available with glides or casters.
- T-leg casters are locking with urethane tread.
- T-leg glides provide ½" adjustment.
- T-leg bases require some assembly.
- AMPTGST support gussets are needed when ordering 60"W or greater tops with T-Legs.
- Height-adjustable post-legs adjust from 26½"H to 32½".
- Post-leg models contain four legs and ship two per carton.
- Post-legs require some assembly.
- Post-leg glides provide 1¼" adjustment.
- Community table legs come in kits of 2, 4, 6, or 8.
- Community legs provide a recessed channel with cover to route cords from floor to undersurface.
- Community leg glides provide 3" adjustment.

Description	Model	Ship Weight	Cubes	List Price		
				P1	P2	P3
T-Leg Bases						
Small, Pair, Seated Height w/Casters	AMPTTSSC	15.0	2.0	\$ 796	\$ 825	\$ 853
Small, Pair, Seated Height w/Glides	AMPTTSSG	15.0	2.0	\$ 796	\$ 825	\$ 853
Medium, Pair, Seated Height w/Casters	AMPTTMSC	17.0	2.0	\$ 865	\$ 896	\$ 926
Medium, Pair, Seated Height w/Glides	AMPTTMSG	17.0	2.0	\$ 865	\$ 896	\$ 926
Large, Pair, Seated Height w/Glides	AMPTTLSG	25.0	3.4	\$ 1104	\$ 1144	\$ 1183
Support Gusset for large tops — Pair	AMPTGST	5.0	0.2	\$ 190	\$ 198	\$ 205

Description	Model	Ship Weight	Cubes	List Price		
				P1	P2	P3
T-Leg Bases — Polished						
Small, Pair, Seated Height w/Casters	AMPTTSSCP	15.0	2.0	\$ 959	\$ 993	\$ 1027
Small, Pair, Seated Height w/Glides	AMPTTSSGP	15.0	2.0	\$ 959	\$ 993	\$ 1027
Medium, Pair, Seated Height w/Casters	AMPTTMSCP	17.0	2.0	\$ 1053	\$ 1091	\$ 1128
Medium, Pair, Seated Height w/Glides	AMPTTMSGP	17.0	2.0	\$ 1053	\$ 1091	\$ 1128
Large, Pair, Seated Height w/Glides	AMPTTLSGP	25.0	3.4	\$ 1300	\$ 1346	\$ 1391

Description	Model	Ship Weight	Cubes	List Price		
				P1	P2	P3
Post-Leg Bases						
Kit of 4, Fixed Height w/Casters	AMPTPLC	13.0	1.2	\$ 795	\$ 817	\$ 838
Adjustable, Kit of 4 w/Casters	AMPTAPLC	13.0	1.2	\$ 978	\$ 1002	\$ 1026
Kit of 4, Fixed Height w/Glides	AMPTPLG	13.0	1.2	\$ 795	\$ 817	\$ 838
Adjustable, Kit of 4 w/Glides	AMPTAPLG	13.0	1.2	\$ 978	\$ 1002	\$ 1026

Description	Model	Ship Weight	Cubes	List Price		
				P1	P2	P3
Community Bases						
2-Leg Base	AMPTCL2	29.0	2.2	\$ 1154	\$ 1196	\$ 1236
2-Leg Base for hardwired use	AMPTCL2HW	29.0	2.2	\$ 1180	\$ 1223	\$ 1264
4-Leg Base	AMPTCL4	58.0	4.4	\$ 2308	\$ 2390	\$ 2470
4-Leg Base for hardwired use	AMPTCL4HW	58.0	4.4	\$ 2360	\$ 2444	\$ 2527
6-Leg Base	AMPTCL6	87.0	6.6	\$ 3462	\$ 3584	\$ 3706
6-Leg Base for hardwired use	AMPTCL6HW	87.0	6.6	\$ 3540	\$ 3665	\$ 3790
8-Leg Base	AMPTCL8	116	8.8	\$ 4616	\$ 4778	\$ 4940
8-Leg Base for hardwired use	AMPTCL8HW	116	8.8	\$ 4720	\$ 4887	\$ 5053

Hardwire Version

How to specify —
Select the Model Number from above.

1st Option:
Paint Finishes:
P1 P2 P3
See page 508 for finishes.

AMPT | | | | | | | | | | . | | | | |

Examples: AMPTTSSC.P27 AMPTAPLG.P27 AMPTCL4HW.P27

Structure

Adjustable Tables / Adaptive Tables

GSA SIN

- Tables feature a self-centering drop leaf and height-adjustable table top. See page 510.
- Table tops are 36" W with drop leaf up and 22¼" W with drop leaf down.
- Tables adjust from 26"H to 33"H.
- Tables feature urethane tread locking casters.
- Round tables have a 35" interface when the drop leaf is down.
- Tables will allow slight rotational movement of the worksurface relative to the base because of the functionality of the height adjustable cylinder.

Description	Model	Ship Weight	Cubes	List Price		
				P1	P2	P3
Height-Adjustable Tables — Laminate Square Edge						
30" Round Band	AMPTLF30HRND	58.0	8.7	\$ 1946	\$ 1973	\$ 1999
36" Round Band	AMPTLF36HRND	70.0	9.7	\$ 2085	\$ 2112	\$ 2138
30" Square Band	AMPTLF30HSQR	66.0	8.7	\$ 1698	\$ 1725	\$ 1751
36" Square Band	AMPTLF36HSQR	80.0	9.7	\$ 1761	\$ 1788	\$ 1814
Height-Adjustable Tables — Laminate Square Edge — Polished						
30" Round Band	AMPTLF30HRNDP	58.0	8.7	\$ 2108	\$ 2135	\$ 2161
36" Round Band	AMPTLF36HRNDP	70.0	9.7	\$ 2247	\$ 2274	\$ 2300
30" Square Band	AMPTLF30HSQRP	66.0	8.7	\$ 1860	\$ 1887	\$ 1913
36" Square Band	AMPTLF36HSQRP	80.0	9.7	\$ 1923	\$ 1950	\$ 1976
Height-Adjustable Tables — Laminate Knife Edge						
30" Round Band	AMPTLK30HRND	58.0	8.7	\$ 3196	\$ 3223	\$ 3249
36" Round Band	AMPTLK36HRND	70.0	9.7	\$ 3474	\$ 3501	\$ 3527
30" Square Band	AMPTLK30HSQR	66.0	8.7	\$ 2694	\$ 2721	\$ 2747
36" Square Band	AMPTLK36HSQR	80.0	9.7	\$ 2905	\$ 2932	\$ 2958
Height-Adjustable Tables — Laminate Knife Edge — Polished						
30" Round Band	AMPTLK30HRNDP	58.0	8.7	\$ 3358	\$ 3385	\$ 3411
36" Round Band	AMPTLK36HRNDP	70.0	9.7	\$ 3636	\$ 3663	\$ 3689
30" Square Band	AMPTLK30HSQRP	66.0	8.7	\$ 2856	\$ 2883	\$ 2909
36" Square Band	AMPTLK36HSQRP	80.0	9.7	\$ 3067	\$ 3094	\$ 3120
Adaptive Tables — Laminate						
36" Round — Flat Edge	AMPTLF36ARND	90.0	10.3	\$ 2057	\$ 2084	\$ 2110
36" Round — Knife Edge	AMPTLK36ARND	90.0	10.3	\$ 4014	\$ 4041	\$ 4067
Adaptive Tables — Laminate Polished						
36" Round — Flat Edge	AMPTLF36ARNDP	90.0	10.3	\$ 2217	\$ 2244	\$ 2270
36" Round — Knife Edge	AMPTLK36ARNDP	90.0	10.3	\$ 4174	\$ 4201	\$ 4227

How to specify —
Select the Model Number from above.

1st Option: FSC Certified Wood: FSC Enter for FSC wood X Enter for non-FSC wood	2nd Option: Laminate: See page 508 for finishes.	3rd Option: Paint: <input type="radio"/> P1 <input type="radio"/> P2 <input type="radio"/> P3 See page 508 for finishes.
--	--	---

A | | | | | | | | | | . | | | | | . | | | | | . | | | | | .

Examples: AMPTLF30HRND.X.LT11.P27 ALN30HSQR.FSC.LLA1.P27 AMPTLK36ARND.X.LLA1.P27

- Table Media Mount is used to mount a television to the end of a table top when not against a wall. Mounting hardware is provided for television sizes 32 to 50 with VESA Mounts of 100x100 to 200x200; for some televisions, additional hardware is required.
- The Wire Management Covers snap on to legs. See wire capacity on page 512.
- Wire basket models include basket and two vertical hanging supports made of .148" dia. steel wire.
- Verticals must be placed 18" or more apart from one another and must be within 15" from each end of the basket. Can hold a maximum load of 25 lbs.
- Table media mount, AMPTTMM, can only be used with the Structure Media Round/Square Pedestal Base Kit found on page 546.

Description	Model	Ship Weight	Cubes	List Price		
				P1	P2	P3
Accessories						
Table Media Mount	AMPTTMM	4.0	0.4	\$ 318	\$ 330	\$ 341
Wire Manager Cover for T-Leg - Medium	AMPTWMCOM	4.0	0.4	\$ 125	\$ 131	\$ 135
Wire Manager Cover for T-Leg - Large	AMPTWMCOL	4.0	0.4	\$ 141	\$ 147	\$ 152
Wire Manager Cover for Medium Column - Short	AMPTWMCRS	4.0	0.4	\$ 125	\$ 131	\$ 135
Wire Manager Cover for Medium Column - Long	AMPTWMCSSL	4.0	0.4	\$ 157	\$ 164	\$ 169
Wire Manager Cover for Large Column - Short	AMPTWMCLRS	4.0	0.4	\$ 174	\$ 181	\$ 187
Wire Manager Cover for Large Column - Long	AMPTWMCLRL	4.0	0.4	\$ 208	\$ 216	\$ 224
Wire Manager Cover for X Base - Short	AMPTWMCXBS	4.0	0.4	\$ 125	\$ 131	\$ 135
Wire Manager Cover for X Base - Long	AMPTWMCXBL	4.0	0.4	\$ 157	\$ 164	\$ 169

Wire Manager Model	Description	Actual Length	Target Bases
AMPTWMCOM	Wire Manager Cover for T-Leg Medium	21"	All Small & Medium T-Legs
AMPTWMCOL	Wire Manager Cover for T-Leg Large	21"	All Large T-Legs
AMPTWMCRS	Wire Manager Cover for Medium Column - Short	22"	Medium Pedestal Bases, Continental & Seated Heights
AMPTWMCSSL	Wire Manager Cover for Medium Column - Long	33"	Medium Pedestal Bases, Counter & Bar Heights
AMPTWMCLRS	Wire Manager Cover for Large Column - Short	22"	Large Pedestal Bases, Continental & Seated Heights
AMPTWMCLRL	Wire Manager Cover for Large Column - Long	32"	Large Pedestal Base, Counter & Bar Heights
AMPTWMCXBS	Wire Manager Cover for X Base - Short	16"	Medium & Large X Base, Continental & Seated Heights
AMPTWMCXBL	Wire Manager Cover for X Base - Long	25"	Medium and Large X base, Counter & Bar Heights

S Shippable by small-package carrier.

<p>How to specify — Select the Model Number from above.</p>	<p><i>1st Option:</i> Paint Finish (if applicable): P1 P2 P3 See page 508 for finishes.</p>
--	--

Examples: AMPTWMB.FOG

- The Cable Management Tray attaches under the surface and is 4" deep to contain cables, a power strip and/or surge protector.
- Wire management channel has self adhesive backing to attach to panels or underside of surface.
- Each wire-management channel has 2 cavities that can hold six .22" dia. cables
- A cord management snake is used to route and conceal power/data cables from outlet to undersurface. Includes all mounting hardware and a plate to secure to leveling glide. Can house six .300" dia. cables.

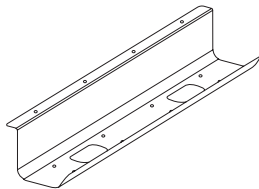

AJTRGH24

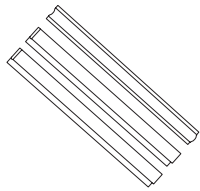

AWRSTRIP

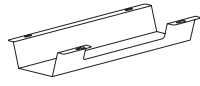

APWRTRGH17

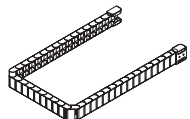

WKSWMC

Description	Model	List Price		
		P1	P2	P3

Cable Management Trays

24"W	AJTRGH24	\$ 123	N/A	N/A
36"W	AJTRGH36	\$ 147	N/A	N/A

- Available in 24" or 36" widths.
- Metal Cable Management Trays available in Black only, specify "P" for finish.
- Example: AJTRGH24.P

Wire Management Strips/Channels

	AWRSTRIP	\$ 270	N/A	N/A
--	----------	--------	-----	-----

- Four wire management strips/channels in black only, no specification needed.
- Example: AWRSTRIP

Under Worksurface Troughs

17"W	APWRTRGH17	\$ 108	N/A	N/A
36"W	APWRTRGH36	\$ 189	N/A	N/A

- Available in 17" or 36" widths.
- Under Worksurface Troughs available in Black only, no specification needed.
- Example: APWRTRGH17

Wire Management Chains

36"	A9CLWMC	\$ 357	N/A	N/A
58"	WKSWMC	\$ 428	N/A	N/A

- Specify model A9CLWMC for 36" chain, specify model WKSWMC for 58" chain.
- A9CLWMC available in Black (E4), White (DW), or Silver (TI).
- WKSWMC available in Black only, no specification needed.
- Example: A9CLWMC.DW or WKSWMC

<p>How to specify — Select the Model Number from above.</p>	<p>1st Option: Paint (if applicable): See page 31 for finishes.</p> <p>Plastics (if applicable): DW White TI Silver E4 Black</p>
--	---

Examples: AJTRGH24.P A9CLWMC.DW

Shippable by small-package carrier.

- 10' corded power models used in C1, C2, and C3 cutouts.
- Power/data ports used in G1 or ATE cutouts.
- HDMI and VGA Kits to be used in data ports on electrical models.

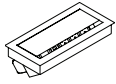

Description	Model	Ship Weight	Cubes	List Price P1
Hardwire Power Solutions (Surface Mounted)				
10' hardwire power includes 4 power/2 data ports	AMPTP1HW	5.0	0.4	\$ 1115
10' hardwire power includes 3 power/1 Extron cut-out	AMPTP2HW	5.0	0.4	\$ 1006
10' hardwire power includes 3 power/1 USB-A, 1 USB-C/2 data ports	AMPTP3HW	5.0	0.4	\$ 1225
10' hardwire power includes 3 power/1 USB-A, 1 USB-C/Wireless Charging	AMPTP4HW	5.0	0.4	\$ 1429

Note: For use with C1, C2, and C3 cutouts.

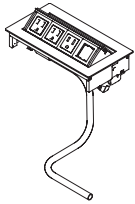

Power/Data Ports				
Power Harness Hardwired – 3 AC / 1 Open Data	AW4P2H S	3	1.9	\$ 626

Note: For use with G1 or ATE cutouts.

STRUCTURE

<p>How to specify — Select the Model Number from above.</p>	<p><i>1st Option:</i> Paint Finish (if applicable): P1 P2 See page 508 for finishes.</p>
<p>Examples:</p>	

- 10' corded power models used in C1, C2, and C3 cutouts.
- Power/data ports used in G1 or ATE cutouts.
- HDMI and VGA Kits to be used in data ports on electrical models.

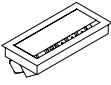
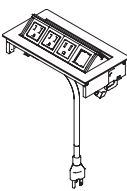
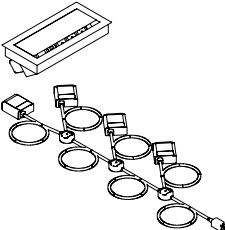
	Description	Model	Ship Weight	Cubes	List Price P1
	Corded Power Solutions (Surface Mounted)				
	10' corded power includes 4 power/2 data ports	AMPTP1	5.0	0.4	\$ 971
	10' corded power includes 3 power/1 Extron cut-out	AMPTP2	5.0	0.4	\$ 863
	10' corded power includes 3 power/1 USB-A, 1 USB-C/2 data ports	AMPTP3	5.0	0.4	\$ 1083
	10' corded power includes 3 power/1 USB-A, 1 USB-C/Wireless Charging	AMPTP4	5.0	0.4	\$ 1296
	Note: For use with C1, C2, and C3 cutouts.				
	Power/Data Ports				
	Power Harness Corded – 3 AC / 1 Open Data	AW4P2C S	3	1.9	\$ 626
	Note: For use with G1 or ATE cutouts.				
	Under Surface Power Solutions				
	Small Undersurface mount power — 2 modules including 1 A/C and Dual USB	AMPTUSPS2	5.0	0.1	\$ 855
	Small Undersurface mount power — 1 module including 2 A/C - Corded	AMPTUSPS1A	5.0	0.1	\$ 201
	Small Undersurface mount power — 1 module including 1 A/C, 1 USB-A, and 1 USB-C - Corded	AMPTUSPS1U	5.0	0.1	\$ 469
	Small Undersurface mount power — 4 modules including 1 A/C, 1 USB-A, and 1 USB-C	AMPTUSPS4	5.0	0.1	\$ 1801
	Medium Undersurface mount power — 4 modules including 1 A/C, 1 USB-A, and 1 USB-C	AMPTUSPM4	5.0	0.1	\$ 1812
	Large Undersurface mount power — 3 modules including 1 A/C, 1 USB-A, and 1 USB-C	AMPTUSPL3	5.0	0.1	\$ 1368
	Large Undersurface mount power — 4 modules including 1 A/C, 1 USB-A, and 1 USB-C	AMPTUSPL4	5.0	0.1	\$ 1817
Structure XL Under Top Power 4-Modules with 1 A/C, 1 USB-A, and 1 USB-C	AMPTUSPXL4	5.0	0.1	\$ 1826	

STRUCTURE

<p>How to specify — Select the Model Number from above.</p>	<p><i>1st Option:</i> Paint Finish (if applicable):</p> <p>P1 P2</p> <p>See page 508 for finishes.</p>
--	---

Examples: AMPTP1.FOG AMPTUSPM4 AMPTUSPS1U

- 10' corded power models used in C1, C2, and C3 cutouts.
- Power/data ports used in G1 or ATE cutouts.
- HDMI and VGA Kits to be used in data ports on electrical models.

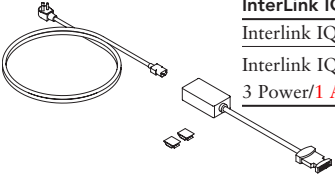

Description	Model	Ship Weight	Cubes	List Price P1
InterLink IQ				
Interlink IQ Starter with 72" Infeed cord	AW4QBI S	2.0	0.2	\$ 853
Interlink IQ Power Harness — 3 Power/1 A/C, 1 USB-A, and 1 USB-C/2 OpenWindows	AM4QH3P1U2B	5.0	0.2	\$ 1348
Extron Plate (Double Space) — VGA, HDMI, HDMI, Audio				
Extron Plate (Double Space) — VGA, HDMI, HDMI, Audio	AMPTPLATE	5.0	0.1	\$ 763
VGA Kit	AMPTPVG	5.0	0.1	\$ 328
HDMI Kit	AMPTPHI	5.0	0.1	\$ 234



Description	Model	Ship Weight	Cubes	List Price
Universal Hook (Black only)				
Package of 2	AGSAUHK S	3	0.2	\$ 132
Ganging Bracket				
Bracket includes Hardware	AW4GANG S	0.2	0.0	\$ 101

How to specify —
Select the Model Number from above.

1st Option:
Paint Finish
(if applicable):
P1 P2
See page 508 for finishes.

Examples: AMPTPLATE AMPTPVG

GSA SIN 33721

Description	Model	P1 Paint List Price	P2 Paint List Price
Touch-Up Paint — Brush			
Bottle of Touch-Up Paint with Brush — 0.5 oz.	APTK S	\$ 102	\$ 114
Touch-Up Paint — Spray			
Spray Can of Touch-Up Paint — 12 oz.	ARSLCC S	\$ 102	\$ 114

How to specify —
Select the Model Number from above.

A | | | | | | | | | | .

1st Option:

Paint Color:

P1 P2 P3

See available Touch-Up Paint colors listed above. Some colors are limited to brush or spray.

| | | | | | | | | |

Examples: APTK.P02 ARSLCC.P02

S Shippable by small-package carrier.

Cleaning instructions are listed on the back of our fabric cards and are available in written form upon request.

CLEANING CODES

- D** Dry clean only.
- L** Clean with warm water and mild soap, using clean cloth, as soon as possible.
- P** Clean with detergent and water or perchlorethylene.
- R** Detailed recommended cleaning and/or disinfecting procedures are available upon request.
- S** Only pure, water-free solvents may be used. CAUTION: Use of water-based or detergent-based solvents may cause shrinking and/or permanent water stains.
- SM** Same as S. Do not brush.
- SW** Clean with water-based cleaning agents, foam or pure water-free solvents (Energine, Carbona, Renuzit, or other similar products). Vacuuming or light brushing is recommended to prevent dust and soil buildup.
- W** Water-based cleaning agents or foam may be used.
- WS** See SW.
- X** Brush or vacuum only.
- XS** Brush and vacuum only, NO liquid cleaners.

CLEANING VINYL

Vinyl-coated fabrics are perhaps the most maintenance-free fabrics ever produced and certainly will provide exceptional service life if given proper care. Almost all vinyl manufacturers now provide information concerning the necessary cleaning procedures for their products. In reality, all care and maintenance instructions are the same for all coated fabrics regardless of their manufacturing origin.

Everyday soil — A gentle mixture of any mild soap and warm water will generally dissipate most common soil from the surface. Using a soft cloth, wash the area to be cleaned and rinse. If stubborn dirt remains, such as a stain embedded in the grain of the vinyl, use a soft brush, and if necessary, a touch of cleaning powder. In both situations, rinse and dry with a soft cloth.

Gum — Remove as much chewing gum as possible prior to the application of Naptha or Kerosene, worked in with a soft cloth. If gum cannot be removed, ice may be used to harden the gum so that it separates itself from the vinyl surface. (This same method is also useful in removing wax.)

Ink Spots — You must work quickly! Magic Marker, India ink, and ballpoint pen immediately will affect pigments, and, for the most part, are difficult to remove. It is recommended that a solution of water and rubbing alcohol be applied and gently rubbed on the spot as soon as possible. Hair sprays containing alcohol are sometimes effective in emergencies for removing ink.

Nail Polish and Polish Remover — These products will immediately damage vinyl surfaces and, to retard further damage, should be carefully wiped clean.

Paint — Try to remove as soon as possible. It is not recommended that any paint removers or brush cleaners be used. Clean oil-based paints with a soft clean cloth and Naptha. To clean latex-based paints, use the same method as recommended for everyday soil.

Tar, Asphalt, Etc. — Petroleum-based products will stain all vinyl if allowed to stand too long. Clean as soon as possible with a cloth followed by the immediate application of Kerosene or Naptha.

Products are now on the market that are manufactured to enhance the beauty and service life of all vinyl. However, by using the methods described above with sensible care and attention, the consumer should enjoy years of satisfaction and pride with any vinyl-coated fabrics.

CLEANING LEATHER

Because leather is a natural product, it needs very little or no care during normal usage.

Spots and Spills — Wipe excess liquid up immediately with a clean, absorbent cloth or sponge. If necessary, use clean lukewarm water only and let dry naturally. If water is used, clean the entire area where the spot occurred. An example would be the entire seat cushion or the entire arm. Do not dry wet areas with hair dryers, etc.

Stubborn Spots and Stains — Use a mild, non-detergent cleaner such as bar or Ivory soap. Apply the soap to a clean, wet sponge and wash, then rinse well. Allow to dry naturally.

Butter, Oil, or Grease — Wipe excess butter, oil or grease off of the leather with a clean dry cloth, then leave it alone as the spot should dissipate into the leather in a short period of time. Do not apply water or try to wash a butter, oil, or grease spot.

DO NOT USE saddle soap, cleaning solvent, furniture polish, oils, varnish, abrasive cleaners, soaps, window cleaner, or ammonia water.

Allsteel, as an HNI company, adheres to the HNI Enterprise Sustainability Policy of 2008 and its related procedures. The Design for the Environment Procedure directs the product design process to consider potential environmental impacts of the product; including materials selection, packaging and transport, product use, and design for disassembly at the end of the product's useful life. The Manufacture for the Environment Procedure sets goals related to energy efficiency, waste recycling, air emissions reductions, worker safety, water efficiency, increased renewable energy, and chemical reductions.

The Enterprise Sustainability Policy sets goals and measures results, driven by the ANSI/BIFMA e3 Furniture Sustainability Standard and evaluated in the 3rd party certification called level®. Rigorous quantitative evaluation criteria cover four categories: materials, energy and atmosphere, human and ecosystem health, and social responsibility. The audit process evaluates the individual products, the manufacturing site(s), and the corporation. Allsteel's furniture is level 2 and level 3 certified to the standard. (ANSI is the American National Standards Institute, an organization that directs the transparent development process of national standards.)

In addition, Allsteel's products support requirements of LEED (Leadership in Energy and Environmental Design), the green building rating system. Whether a customer seeks to achieve LEED certification or just obtain the benefits without certification, Allsteel's products meet the standards set forth in LEED. Allsteel is proud to support sustainability initiatives in the building industry as a member of the U.S. Green Building Council (USGBC).

Allsteel complies with the Federal Trade Commission Part 260 Guide for the Use of Environmental Marketing Claims. Our third-party certifications support our environmental statements and our credibility. Third-party certification involves an independent assessment declaring that specified requirements pertaining to a product, process or management system have been met. Allsteel's third party certifications include BIFMA level® 2, SCS Indoor Advantage™ Gold, and FSC®. Select products are Cradle to Cradle Certified™ Bronze and/or have third party certified Environmental Product Declarations.

Nearly all of Allsteel's products are level 2 or level 3 and Indoor Advantage Gold certified. FSC® certified products are available; check price lists for details.

Visit our website for the latest Allsteel sustainability information: allsteeloffice.com.

Cross Reference Index

by Model Number

Model	Page	Model	Page	Model	Page	Model	Page
831124.....	481	A876072A	429	AF5RND6024D.....	424	AJTRGH24.....	427, 453.2, 551.1
831130.....	481	A877012	429	AF5RND6030D.....	424	AJTRGH36.....	427, 453.2, 551.1
873600.....	430	AABPWARMOD.....	243, 251.1, 427.2, 453	AF5RND6624D.....	424	AKMH.....	442
A6BLUETOOTH.....	423	AALG	50	AF5RND6630D.....	424	AKTLONG.....	442
A6CASTER.....	423	AALP	50	AF5RND7224D.....	424	AKTMD.....	442
A6MREC3S2LCF.....	422	AALS	50	AF5RND7230D.....	424	AKTSHORT.....	442
A6MREC3S2LTF.....	422	AALW	50	AF5RND7824D.....	424	ALED17U.....	451
A6MREC3S3LCF.....	423	AAMG	50	AF5RND7830D.....	424	ALED17U60.....	451
A6MREC3S3LTF.....	423	AAMP	50	AF5RND8424D.....	424	ALED17UJMP30.....	451
A6REC2S2LCF.....	422	AAMS	50	AF5RND8430D.....	424	ALED31U.....	451
A6REC2S2LTF.....	422	AAMW	50	AF5RND9024D.....	424	ALED31U60.....	451
A6REC2S3LCF.....	423	AAPAC.....	447.1	AF5RND9030D.....	424	ALED31UJMP30.....	451
A6REC2S3LTF.....	423	AAPACM2.....	451	AF5RND9624D.....	424	ALEDOCC.....	451
A6REC3S2LCF.....	422	AAPAH.....	447.1	AF5RND9630D.....	424	ALEGCHASE26.....	453.3
A6REC3S2LTF.....	422	AAPAHF.....	447.1	AF5RS3624U.....	425	AM4QH3P1U2B.....	485, 554
A6REC3S3LCF.....	423	AAPAMP.....	447.1	AF5RS3630U.....	425	AMADHD.....	456
A6REC3S3LTF.....	423	AAPASB.....	447.1	AF5RS4224U.....	425	AMASD.....	456
A6SLDGLIDE.....	423	AAPASH.....	447.1	AF5RS4230U.....	425	AMASD-G.....	456
A9CLWMC.....	427, 453.2, 551.1	AAPAST.....	447.1	AF5RS4824.....	424	AMASHD.....	456
A87P2U1R.....	486	AAS1520.....	433	AF5RS4824U.....	425	AMASHDCK.....	457
A5622ELS.....	426	AAS1548.....	433	AF5RS4830.....	424	AMASTS.....	456
A5622ERS.....	426	AAS1554.....	433	AF5RS4830U.....	425	AMASTSCK.....	457
A5722ELS.....	426	AAS1560.....	433	AF5RS5424.....	424	AMASTS-G.....	456
A5722ERS.....	426	AAS1566.....	433	AF5RS5424U.....	425	AMPCCHASE.....	453.3
A5822ELS.....	426	AAS1572.....	433	AF5RS5430.....	424	AMPTAPLC.....	549
A5822ERS.....	426	ABPWARMOD.....	395	AF5RS5430U.....	425	AMPTAPLG.....	549
A5922ELS.....	426	ACD1.....	448	AF5RS6024D.....	424	AMPTCB.....	543
A5922ERS.....	426	ACDIV.....	207	AF5RS6024UD.....	425	AMPTCB84.....	543
A870302.....	486	ACEGUM.....	208	AF5RS6030D.....	424	AMPTCB96.....	543
A870824.....	451	ACEGUS.....	208	AF5RS6030UD.....	425	AMPTCB120.....	543
A870824CH.....	451	ACM-MUCA.....	54	AF5RS6624D.....	424	AMPTCB144.....	543
A870830.....	451	ACM-MUCA.....	54	AF5RS6624UD.....	425	AMPTCB168.....	543
A870830CH.....	451	ACM-MUCO.....	54	AF5RS6630D.....	424	AMPTCB192.....	543
A870842.....	451	ACM-MUGA.....	54	AF5RS6630UD.....	425	AMPTCB216.....	543
A870842CH.....	451	ACM-MUGO.....	54	AF5RS7224D.....	424	AMPTCB240.....	543
A870860.....	451	ACPERU.....	214	AF5RS7224UD.....	425	AMPTCBST.....	543
A870860CH.....	451	ACPICT.....	212, 348	AF5RS7230D.....	424	AMPTCBST84.....	543
A871124.....	428	ACPICT30.....	212, 348	AF5RS7230UD.....	425	AMPTCBST96.....	543
A871124A.....	428	ACPU1.....	442	AF5RS7824D.....	424	AMPTCBST120.....	543
A871148.....	428	ACPWARMOD.....	453	AF5RS7824UD.....	425	AMPTCBST144.....	543
A871148A.....	428	ACVISCTBL.....	206, 347	AF5RS7830D.....	424	AMPTCBST168.....	543
A871160.....	428	ACVISDLM.....	204	AF5RS7830UD.....	425	AMPTCBST192.....	543
A871160A.....	428	ACVISDLS.....	204	AF5RS8424D.....	424	AMPTCBST216.....	543
A871172.....	428	ACVISDRM.....	204	AF5RS8424UD.....	425	AMPTCBST240.....	543
A871172A.....	428	ACVISDRS.....	204	AF5RS8430D.....	424	AMPTCL2.....	549
A871248.....	428	ACVISOTS.....	204	AF5RS8430UD.....	425	AMPTCL2HW.....	549
A871248A.....	428	ACVISSLM.....	204	AF5RS9024D.....	424	AMPTCL4.....	549
A871254.....	428	ACVISSL.....	204	AF5RS9024UD.....	425	AMPTCL4HW.....	549
A871254A.....	428	ACVISSRM.....	204	AF5RS9030D.....	424	AMPTCL6.....	549
A871260.....	428	ACVISSRS.....	204	AF5RS9030UD.....	425	AMPTCL6HW.....	549
A871260A.....	428	ACVISTBL.....	206, 347	AF5RS9624D.....	424	AMPTCL8.....	549
A871266.....	428	ACWEDM.....	210	AF5RS9624UD.....	425	AMPTCL8HW.....	549
A871266A.....	428	ACWEDS.....	210	AF5RS9630D.....	424	AMPTCYL.....	544
A871272.....	428	AECH.....	433	AF5RS9630UD.....	425	AMPTCYL84.....	544
A871272A.....	428	AEHF.....	433	AF5120S4224D.....	425	AMPTCYL96.....	544
A871400.....	429	AESS.....	433	AF5120S4230D.....	425	AMPTCYL120.....	544
A871400A.....	429	AF5CCS5424.....	425	AF5120S4824D.....	425	AMPTCYL144.....	544
A871501A.....	429	AF5CCS5430.....	425	AF5120S4830D.....	425	AMPTCYL168.....	544
A871502A.....	429	AF5CCS603624LD.....	426	AF5120S5424D.....	425	AMPTCYL192.....	544
A871503A.....	429	AF5CCS603624RD.....	426	AF5120S5430D.....	425	AMPTCYL216.....	544
A871601.....	429	AF5CCS604824LD.....	426	AFDTRGH20.....	427, 453.2	AMPTCYL240.....	544
A871601A.....	429	AF5CCS604824RD.....	426	AFDTRGH32.....	427, 453.2	AMPTCYLSM.....	544
A871912.....	429	AF5CCS604830LD.....	426	AFLG.....	50	AMPTCYLWM.....	544
A871912A.....	429	AF5CCS604830RD.....	426	AFLP.....	50	AMPTCYLWM84.....	544
A871918.....	429	AF5CCS723624LD.....	426	AFLS.....	50	AMPTCYLWM96.....	544
A871918A.....	429	AF5CCS723624RD.....	426	AFLW.....	50	AMPTCYLWM120.....	544
A871972.....	429	AF5CCS724824LD.....	426	AFMG.....	50	AMPTCYLWM144.....	544
A871972A.....	429	AF5CCS724824RD.....	426	AFMP.....	50	AMPTCYLWM168.....	544
A873501.....	429	AF5CCS724830LD.....	426	AFMS.....	50	AMPTCYLWM192.....	544
A873502.....	429	AF5CCS724830RD.....	426	AFMW.....	50	AMPTCYLWM216.....	544
A873503.....	429	AF5RND4824.....	424	AGSAUHK.....	438, 483, 554	AMPTCYLWM240.....	544
A873504.....	429	AF5RND4830.....	424	AHATPWARMOD2S.....	427.3, 453.4	AMPTGST.....	549
A873506.....	429	AF5RND5424.....	424	AHATPWARMOD3S.....	427.3, 453.4	AMPTLF30HRND.....	550
A876072.....	429	AF5RND5430.....	424	AHATPWARMODF.....	427.3, 453.4	AMPTLF30HRNDP.....	550

Cross Reference Index

by Model Number

Model	Page	Model	Page	Model	Page	Model	Page
AMPTLF30HSQR	550	AMPTLF4860MRE	540	AMPTLFPO245QR	529	AMPTLK3696RE	538
AMPTLF30HSQR	550	AMPTLF4860MRT	541	AMPTLFPO245SQR	530	AMPTLK3696RT	535
AMPTLF36ARND	550	AMPTLF4872DIA	531	AMPTLFPO30RND	528	AMPTLK4260RE	538
AMPTLF36ARNDP	550	AMPTLF4872RE	537	AMPTLFPO30SSQR	529	AMPTLK4272DIA	531
AMPTLF36HRND	550	AMPTLF4872RT	534	AMPTLFPO30SSQR	530	AMPTLK4272RE	538
AMPTLF36HRNDP	550	AMPTLF4884DIA	531	AMPTLFPO36RND	528	AMPTLK4272RT	535
AMPTLF36HSQR	550	AMPTLF4884RE	537	AMPTLFPO36SQR	529	AMPTLK4284DIA	531
AMPTLF36HSQR	550	AMPTLF4884RT	534	AMPTLFPO36SSQR	530	AMPTLK4284RE	538
AMPTLF54RND	528	AMPTLF4896DIA	531	AMPTLFPO42RND	528	AMPTLK4284RT	535
AMPTLF54SSQR	529	AMPTLF4896RE	537	AMPTLFPO42SQR	529	AMPTLK4296DIA	531
AMPTLF54SSQR	530	AMPTLF4896RT	534	AMPTLFPO42SSQR	530	AMPTLK4296RE	538
AMPTLF60RND	528	AMPTLF5454MDIA	541	AMPTLFPO48RND	528	AMPTLK4296RT	535
AMPTLF60SQR	529	AMPTLF5454MRE	540	AMPTLFPO48SQR	529	AMPTLK4854MDIA	541
AMPTLF60SSQR	530	AMPTLF5454MRT	541	AMPTLFPO48SSQR	530	AMPTLK4854MRE	540
AMPTLF72RND	528	AMPTLF5460MDIA	541	AMPTLK30HRND	550	AMPTLK4854MRT	541
AMPTLF72SQR	529	AMPTLF5460MRE	540	AMPTLK30HRNDP	550	AMPTLK4860MDIA	541
AMPTLF72SSQR	530	AMPTLF5460MRT	541	AMPTLK30HSQR	550	AMPTLK4860MRE	540
AMPTLF84RND	528	AMPTLF5472MDIA	541	AMPTLK30HSQR	550	AMPTLK4860MRT	541
AMPTLF84SQR	529	AMPTLF5472MRE	540	AMPTLK36ARND	550	AMPTLK4872DIA	531
AMPTLF84SSQR	530	AMPTLF5472MRT	541	AMPTLK36ARNDP	550	AMPTLK4872RE	538
AMPTLF2436RE	537	AMPTLF5496DIA	531	AMPTLK36HRND	550	AMPTLK4872RT	535
AMPTLF2436RT	534	AMPTLF5496RE	537	AMPTLK36HRNDP	550	AMPTLK4884DIA	531
AMPTLF2440DIA	531	AMPTLF5496RT	534	AMPTLK36HSQR	550	AMPTLK4884RE	538
AMPTLF2442RE	537	AMPTLF6060MDIA	541	AMPTLK36HSQR	550	AMPTLK4884RT	535
AMPTLF2442RT	534	AMPTLF6060MRE	540	AMPTLK36HRND	528	AMPTLK4896DIA	531
AMPTLF2448RE	537	AMPTLF6060MRT	541	AMPTLK36HRNDP	529	AMPTLK4896RE	538
AMPTLF2448RT	534	AMPTLF6072MDIA	541	AMPTLK36HRNDP	528	AMPTLK4896RT	535
AMPTLF2460RE	537	AMPTLF6072MRE	540	AMPTLK36HRNDP	528	AMPTLK4896RT	541
AMPTLF2460RT	534	AMPTLF6072MRT	541	AMPTLK60SQR	529	AMPTLK4896RT	541
AMPTLF2472RE	537	AMPTLF36120RE	539	AMPTLK60SSQR	530	AMPTLK5454MRE	540
AMPTLF2472RT	534	AMPTLF36144RE	539	AMPTLK72RND	528	AMPTLK5454MRT	541
AMPTLF2484RE	537	AMPTLF42120RE	539	AMPTLK72SSQR	528	AMPTLK5460DIA	541
AMPTLF2484RT	534	AMPTLF42120RT	536	AMPTLK72SSQR	530	AMPTLK5460MRE	540
AMPTLF3042RE	537	AMPTLF42144RE	539	AMPTLK84RND	528	AMPTLK5460MRT	541
AMPTLF3042RT	534	AMPTLF42144RT	536	AMPTLK84SQR	529	AMPTLK5472MDIA	541
AMPTLF3048RE	537	AMPTLF48120DIA	532	AMPTLK84SSQR	530	AMPTLK5472MRE	540
AMPTLF3048RT	534	AMPTLF48120RE	539	AMPTLK84SSQR	530	AMPTLK5472MRT	541
AMPTLF3050DIA	531	AMPTLF48120RT	536	AMPTLK2436RE	538	AMPTLK5496DIA	531
AMPTLF3052BT	533	AMPTLF48144DIA	532	AMPTLK2436RT	535	AMPTLK5496RE	538
AMPTLF3060BT	533	AMPTLF48144RE	539	AMPTLK2440DIA	531	AMPTLK5496RT	535
AMPTLF3060RE	537	AMPTLF48144RT	536	AMPTLK2442RE	538	AMPTLK6060MDIA	541
AMPTLF3060RT	534	AMPTLF54120DIA	532	AMPTLK2442RT	535	AMPTLK6060MRE	540
AMPTLF3072BT	533	AMPTLF54120RE	539	AMPTLK2448RE	538	AMPTLK6060MRT	541
AMPTLF3072RE	537	AMPTLF54120RT	536	AMPTLK2448RT	535	AMPTLK6072MDIA	541
AMPTLF3072RT	534	AMPTLF54144DIA	532	AMPTLK2460RE	538	AMPTLK6072MRE	540
AMPTLF3084RE	537	AMPTLF54144RE	539	AMPTLK2460RT	535	AMPTLK6072MRT	541
AMPTLF3084RT	534	AMPTLF54144RT	536	AMPTLK2472RE	538	AMPTLK36120RE	539
AMPTLF3648RE	537	AMPTLF54168DIA	532	AMPTLK2472RT	535	AMPTLK36144RE	539
AMPTLF3648RT	534	AMPTLF54168RE	539	AMPTLK2484RE	538	AMPTLK42120RE	539
AMPTLF3652BT	533	AMPTLF54168RT	536	AMPTLK2484RT	535	AMPTLK42120RT	536
AMPTLF3660BT	533	AMPTLF54192DIA	532	AMPTLK3042RE	538	AMPTLK42144RE	539
AMPTLF3660RE	537	AMPTLF54192RE	539	AMPTLK3042RT	535	AMPTLK42144RT	536
AMPTLF3660RT	534	AMPTLF54192RT	536	AMPTLK3048RE	538	AMPTLK48120DIA	532
AMPTLF3672BT	533	AMPTLF54216RE	539	AMPTLK3048RT	535	AMPTLK48120RE	539
AMPTLF3672RE	537	AMPTLF54216RT	536	AMPTLK3050DIA	531	AMPTLK48120RT	536
AMPTLF3672RT	534	AMPTLF54240RE	539	AMPTLK3052BT	533	AMPTLK48144DIA	532
AMPTLF3684RE	537	AMPTLF54240RT	536	AMPTLK3060BT	533	AMPTLK48144RE	539
AMPTLF3684RT	534	AMPTLF60120DIA	532	AMPTLK3060RE	538	AMPTLK48144RT	536
AMPTLF3696RE	537	AMPTLF60120RE	539	AMPTLK3060RT	535	AMPTLK54120DIA	532
AMPTLF3696RT	534	AMPTLF60120RT	536	AMPTLK3072BT	533	AMPTLK54120RE	539
AMPTLF4260RE	537	AMPTLF60144DIA	532	AMPTLK3072RE	538	AMPTLK54120RT	536
AMPTLF4272DIA	531	AMPTLF60144RE	539	AMPTLK3072RT	535	AMPTLK54144DIA	532
AMPTLF4272RE	537	AMPTLF60144RT	536	AMPTLK3084RE	538	AMPTLK54144RE	539
AMPTLF4272RT	534	AMPTLF60168DIA	532	AMPTLK3084RT	535	AMPTLK54144RT	536
AMPTLF4284DIA	531	AMPTLF60168RE	539	AMPTLK3648RE	538	AMPTLK54168DIA	532
AMPTLF4284RE	537	AMPTLF60168RT	536	AMPTLK3648RT	535	AMPTLK54168RE	539
AMPTLF4284RT	534	AMPTLF60192DIA	532	AMPTLK3652BT	533	AMPTLK54168RT	536
AMPTLF4296DIA	531	AMPTLF60192RE	539	AMPTLK3660BT	533	AMPTLK54192DIA	532
AMPTLF4296RE	537	AMPTLF60192RT	536	AMPTLK3660RE	538	AMPTLK54192RE	539
AMPTLF4296RT	534	AMPTLF60216RE	539	AMPTLK3660RT	535	AMPTLK54192RT	536
AMPTLF4854MDIA	541	AMPTLF60216RT	536	AMPTLK3672BT	533	AMPTLK54216RE	539
AMPTLF4854MRE	540	AMPTLF60240RE	539	AMPTLK3672RE	538	AMPTLK54216RT	536
AMPTLF4854MRT	541	AMPTLF60240RT	536	AMPTLK3672RT	535	AMPTLK54240RE	539
AMPTLF4860MDIA	541	AMPTLFPO24RND	528	AMPTLK3684RE	538	AMPTLK54240RT	536
				AMPTLK3684RT	535	AMPTLK60120DIA	532

INDEX

Cross Reference Index

by Model Number

Model	Page	Model	Page	Model	Page	Model	Page
AMPTLK60120RE	539	AMPTPRMEDIA36M	546	AMPTXM36G	545	ATLADM-ACCTRAY	393
AMPTLK60120RT	536	AMPTPRMEDIA42M	546	AMPTXM36GP	545	ATLADM-ACCWIREMGR18	392
AMPTLK60144DIA	532	AMPTPS18L	547	AMPTXM42G	545	ATLADM-ACCWIREMGR36	392
AMPTLK60144RE	539	AMPTPS18LPWR	548	AMPTXM42GP	545	ATLADM-ACCWIREMGR48	392
AMPTLK60144RT	536	AMPTPS18M	547	AMS2048LH	432	ATLADM-BAMEDIAM4848B	384
AMPTLK60168DIA	532	AMPTPS18MPWR	548	AMS2048RH	432	ATLADM-BAMEDIAM4848C	384
AMPTLK60168RE	539	AMPTPS26L	547	AMS2048SS	433	ATLADM-BAMEDIAM4848L	384
AMPTLK60168RT	536	AMPTPS26LPWR	548	AMS2048US	432	ATLADM-BAMEDIAM4848S	384
AMPTLK60192DIA	532	AMPTPS26M	547	AMS2054LH	432	ATLADM-BAMEDIAM4860B	384
AMPTLK60192RE	539	AMPTPS26MPWR	548	AMS2054RH	432	ATLADM-BAMEDIAM4860C	384
AMPTLK60192RT	536	AMPTPS29L	547	AMS2054SS	433	ATLADM-BAMEDIAM4860L	384
AMPTLK60216RE	539	AMPTPS29LPWR	548	AMS2054US	432	ATLADM-BAMEDIAM4886S	384
AMPTLK60216RT	536	AMPTPS29M	547	AMS2060LH	432	ATLADM-BAMEDIAM4872B	384
AMPTLK60240RE	539	AMPTPS29MPWR	548	AMS2060RH	432	ATLADM-BAMEDIAM4872C	384
AMPTLK60240RT	536	AMPTPS36L	547	AMS2060SS	433	ATLADM-BAMEDIAM4872L	384
AMPTLKPO48RND	528	AMPTPS36LPWR	548	AMS2060US	432	ATLADM-BAMEDIAM4882S	384
AMPTLKPO245QR	529	AMPTPS36M	547	AMS2066LH	432	ATLADM-BAMEDIAM4884B	384
AMPTLKPO245SQR	530	AMPTPS36MPWR	548	AMS2066RH	432	ATLADM-BAMEDIAM4884C	384
AMPTLKPO30RND	528	AMPTPS42L	547	AMS2066SS	433	ATLADM-BAMEDIAM4884L	384
AMPTLKPO30SQR	529	AMPTPS42LPWR	548	AMS2066US	432	ATLADM-BAMEDIAM4886S	384
AMPTLKPO30SSQR	530	AMPTPS42M	547	AMS2072LH	432	ATLADM-BAMEDIAM4896B	384
AMPTLKPO36RND	528	AMPTPS42MPWR	548	AMS2072RH	432	ATLADM-BAMEDIAM4896C	384
AMPTLKPO36SQR	529	AMPTPSMEDIA18M	546	AMS2072SS	433	ATLADM-BAMEDIAM4896L	384
AMPTLKPO36SSQR	530	AMPTPSMEDIA26M	546	AMS2072US	432	ATLADM-BAMEDIAM4896S	384
AMPTLKPO42RND	528	AMPTPSMEDIA29M	546	AMS3248LH	432	ATLADM-BCONML2048B	389
AMPTLKPO42SQR	529	AMPTPSMEDIA36M	546	AMS3248RH	432	ATLADM-BCONML2048C	389
AMPTLKPO42SSQR	530	AMPTPSMEDIA42M	546	AMS3248SS	433	ATLADM-BCONML2060B	389
AMPTLKPO48RND	528	AMPTPVG	554	AMS3248US	432	ATLADM-BCONML2060C	389
AMPTLKPO48SQR	529	AMPTTLSG	549	AMS3254LH	432	ATLADM-BCONML2072B	389
AMPTLKPO48SSQR	530	AMPTTSGP	549	AMS3254RH	432	ATLADM-BCONML2072C	389
AMPTP1	394, 553	AMPTTMM	386, 551	AMS3254SS	433	ATLADM-BCONML2084B	389
AMPTP1HW	394, 552	AMPTTMSC	549	AMS3254US	432	ATLADM-BCONML2084C	389
AMPTP2	394, 553	AMPTTMSCP	549	AMS3260LH	432	ATLADM-BCONML2096B	389
AMPTP2HW	394, 552	AMPTTMSG	549	AMS3260RH	432	ATLADM-BCONML2096C	389
AMPTP3	394, 553	AMPTTMSGP	549	AMS3260SS	433	ATLADM-BCONMV2048B	389
AMPTP3HW	394, 552	AMPTTSSC	549	AMS3260US	432	ATLADM-BCONMV2048C	389
AMPTP4	394, 553	AMPTTSSCP	549	AMS3266LH	432	ATLADM-BCONMV2060B	389
AMPTP4HW	394, 552	AMPTTSSG	549	AMS3266RH	432	ATLADM-BCONMV2072B	389
AMPTPHI	554	AMPTTSSGP	549	AMS3266SS	433	ATLADM-BCONMV2072C	389
AMPTPL	542	AMPTUSPL3	553	AMS3266US	432	ATLADM-BCONMV2084B	389
AMPTPL84	542	AMPTUSPL4	553	AMS3272LH	432	ATLADM-BCONMV2084C	389
AMPTPL96	542	AMPTUSPM4	553	AMS3272RH	432	ATLADM-BCONMV2096B	389
AMPTPL120	542	AMPTUSPS1A	553	AMS3272SS	433	ATLADM-BCONMV2096C	389
AMPTPL144	542	AMPTUSPS1U	553	AMS3272US	432	ATLADM-BFMEDIAM4848L	384
AMPTPL168	542	AMPTUSPS2	553	APACSM	457	ATLADM-BFMEDIAM4848S	384
AMPTPL192	542	AMPTUSPS4	553	APACW	457	ATLADM-BFMEDIAM4860L	384
AMPTPL216	542	AMPTUSPXL4	553	APADD	456	ATLADM-BFMEDIAM4860S	384
AMPTPL240	542	AMPTWMB	386, 540	APASD	456	ATLADM-BFMEDIAM4872L	384
AMPTPLATE	554	AMPTWMCLRL	551	APASDCK	457	ATLADM-BFMEDIAM4872S	384
AMPTPLC	549	AMPTWMCLRS	551	APATF	456	ATLADM-BFMEDIAM4884L	384
AMPTPLG	549	AMPTWMCOL	551	APMC6	447	ATLADM-BFMEDIAM4884S	384
AMPTPR18L	547	AMPTWMCOM	551	APTK	555	ATLADM-BFMEDIAM4896L	384
AMPTPR18LPWR	548	AMPTWMCSRL	551	APWR4TAP	200, 427.1, 453	ATLADM-BFMEDIAM4896S	384
AMPTPR18M	547	AMPTWMCSRS	551	APWRMOD	453	ATLADM-BFRNDM96S	382
AMPTPR18MPWR	548	AMPTWMCXBL	551	APWRMODEST36	427.2, 453.4	ATLADM-BMTGM4L	380
AMPTPR26L	547	AMPTWMCXBS	551	APWRMODEST48	427.2, 453.4	ATLADM-BMTGM4S	380
AMPTPR26LPWR	548	AMPTXL18G	545	APWRPCK	453.1	ATLADM-BMTGM3636B	380
AMPTPR26M	547	AMPTXL18GP	545	APWRSTRP	453.1	ATLADM-BMTGM3636C	380
AMPTPR26MPWR	548	AMPTXL26G	545	APWRTRGH17	427, 453.2, 551.1	ATLADM-BMTGM3660B	377
AMPTPR29L	547	AMPTXL26GP	545	APWRTRGH36	427, 453.2, 551.1	ATLADM-BMTGM3660C	377
AMPTPR29LPWR	548	AMPTXL29G	545	ARNDPWRMOD	453	ATLADM-BMTGM3660L	376
AMPTPR29M	547	AMPTXL29GP	545	ARSLCC	555	ATLADM-BMTGM3660S	376
AMPTPR29MPWR	548	AMPTXM18C	545	ATADF3	430	ATLADM-BMTGM3672B	377
AMPTPR36L	547	AMPTXM18CP	545	ATADF4	430	ATLADM-BMTGM3672C	377
AMPTPR36LPWR	548	AMPTXM18G	545	ATADJ5	430	ATLADM-BMTGM3672L	376
AMPTPR36M	547	AMPTXM18GP	545	ATADJ6	430	ATLADM-BMTGM3672S	376
AMPTPR36MPWR	548	AMPTXM26C	545	ATADM-ACCFOOTCST	393	ATLADM-BMTGM3684B	377
AMPTPR42L	547	AMPTXM26CP	545	ATADM-ACCFOOTGLD	393	ATLADM-BMTGM3684C	377
AMPTPR42LPWR	548	AMPTXM26G	545	ATLACC-LEGWIREMGR20	393	ATLADM-BMTGM3684L	376
AMPTPR42M	547	AMPTXM26GP	545	ATLACC-LEGWIREMGR22	393	ATLADM-BMTGM3684S	376
AMPTPR42MPWR	548	AMPTXM29C	545	ATLACC-LEGWIREMGR26	393	ATLADM-BMTGM3696B	377
AMPTPRMEDIA18M	546	AMPTXM29CP	545	ATLACC-LEGWIRESTP	393	ATLADM-BMTGM3696C	377
AMPTPRMEDIA26M	546	AMPTXM29G	545	ATLADM-ACCDSPAD	392	ATLADM-BMTGM3696L	376
AMPTPRMEDIA29M	546	AMPTXM29GP	545	ATLADM-ACCHOOK	393	ATLADM-BMTGM3696S	376

Cross Reference Index

by Model Number

Model	Page	Model	Page	Model	Page	Model	Page
ATLADM-BMTGM4242B.....	380	ATLADM-BMTGMV4848B.....	380	ATLADM-MODV60.....	371	ATLADM-TFBOATL2478K.....	368
ATLADM-BMTGM4242C.....	380	ATLADM-BMTGMV4848C.....	380	ATLADM-MODV66.....	371	ATLADM-TFBOATL2484F.....	368
ATLADM-BMTGM4272B.....	377	ATLADM-BMTGMV5454B.....	380	ATLADM-MODV72.....	371	ATLADM-TFBOATL2484K.....	368
ATLADM-BMTGM4272C.....	377	ATLADM-BMTGMV5454C.....	380	ATLADM-MODV78.....	371	ATLADM-TFBOATL3060F.....	368
ATLADM-BMTGM4272L.....	376	ATLADM-BMTGMV6060B.....	380	ATLADM-MODV84.....	371	ATLADM-TFBOATL3060K.....	368
ATLADM-BMTGM4272S.....	376	ATLADM-BMTGMV6060C.....	380	ATLADM-MTWALLFL60B.....	385	ATLADM-TFBOATL3066F.....	368
ATLADM-BMTGM4284B.....	377	ATLADM-BPERM2048B.....	388	ATLADM-MTWALLFL60C.....	385	ATLADM-TFBOATL3066K.....	368
ATLADM-BMTGM4284C.....	377	ATLADM-BPERM2048C.....	388	ATLADM-MTWALLFL60L.....	385	ATLADM-TFBOATL3072F.....	368
ATLADM-BMTGM4284L.....	376	ATLADM-BPERM2060B.....	388	ATLADM-MTWALLFL60S.....	385	ATLADM-TFBOATL3072K.....	368
ATLADM-BMTGM4284S.....	376	ATLADM-BPERM2060C.....	388	ATLADM-MTWALLFV60B.....	385	ATLADM-TFBOATL3078F.....	368
ATLADM-BMTGM4296B.....	377	ATLADM-BPERM2072B.....	388	ATLADM-MTWALLFV60C.....	385	ATLADM-TFBOATL3078K.....	368
ATLADM-BMTGM4296C.....	377	ATLADM-BPERM2072C.....	388	ATLADM-MTWALLFV60L.....	385	ATLADM-TFBOATL3084F.....	368
ATLADM-BMTGM4296L.....	376	ATLADM-BPERM2084B.....	388	ATLADM-MTWALLFV60S.....	385	ATLADM-TFBOATL3084K.....	368
ATLADM-BMTGM4296S.....	376	ATLADM-BPERM2084C.....	388	ATLADM-MTWFLTFV6040.....	385	ATLADM-TFBOATV2460F.....	368
ATLADM-BMTGM4848B.....	380	ATLADM-BPERM2096B.....	388	ATLADM-MTWFLTFV6040.....	385	ATLADM-TFBOATV2460K.....	368
ATLADM-BMTGM4848C.....	380	ATLADM-BPERM2096C.....	388	ATLADM-TBMEDEV4848F.....	383	ATLADM-TFBOATV2466K.....	368
ATLADM-BMTGM4872B.....	377	ATLADM-BPROJML2436B.....	390	ATLADM-TBMEDEV4848K.....	383	ATLADM-TFBOATV2472F.....	368
ATLADM-BMTGM4872C.....	377	ATLADM-BPROJML2436C.....	390	ATLADM-TBMEDEV4860F.....	383	ATLADM-TFBOATV2478F.....	368
ATLADM-BMTGM4872L.....	376	ATLADM-BPROJML2442B.....	390	ATLADM-TBMEDEV4860K.....	383	ATLADM-TFBOATV2478K.....	368
ATLADM-BMTGM4872S.....	376	ATLADM-BPROJML2442C.....	390	ATLADM-TBMEDEV4872F.....	383	ATLADM-TFBOATV2484F.....	368
ATLADM-BMTGM4884B.....	377	ATLADM-BPROJML2448B.....	390	ATLADM-TBMEDEV4872K.....	383	ATLADM-TFBOATV2484K.....	368
ATLADM-BMTGM4884C.....	377	ATLADM-BPROJML2448C.....	390	ATLADM-TBMEDEV4884F.....	383	ATLADM-TFBOATV3060F.....	368
ATLADM-BMTGM4884L.....	376	ATLADM-BPROJMV2436B.....	390	ATLADM-TBMEDEV4884K.....	383	ATLADM-TFBOATV3060K.....	368
ATLADM-BMTGM4884S.....	376	ATLADM-BPROJMV2436C.....	390	ATLADM-TBMEDEV4896F.....	383	ATLADM-TFBOATV3066F.....	368
ATLADM-BMTGM4896B.....	377	ATLADM-BPROJMV2442B.....	390	ATLADM-TBMEDEV4896K.....	383	ATLADM-TFBOATV3066K.....	368
ATLADM-BMTGM4896C.....	377	ATLADM-BPROJMV2442C.....	390	ATLADM-TBMEDEV4884F.....	383	ATLADM-TFBOATV3072F.....	368
ATLADM-BMTGM4896L.....	376	ATLADM-BPROJMV2448B.....	390	ATLADM-TBMEDEV4884K.....	383	ATLADM-TFBOATV3072K.....	368
ATLADM-BMTGM4896S.....	376	ATLADM-BPROJMV2448C.....	390	ATLADM-TBMEDEV4860F.....	383	ATLADM-TFBOATV3078F.....	368
ATLADM-BMTGM5454B.....	380	ATLADM-BRFXINM48S.....	370	ATLADM-TBMEDEV4860K.....	383	ATLADM-TFBOATV3078K.....	368
ATLADM-BMTGM5454C.....	380	ATLADM-BRFXINM54S.....	370	ATLADM-TBMEDEV4872F.....	383	ATLADM-TFBOATV3084F.....	368
ATLADM-BMTGM6060B.....	380	ATLADM-BRFXINM60S.....	370	ATLADM-TBMEDEV4872K.....	383	ATLADM-TFBOATV3084K.....	368
ATLADM-BMTGM6060C.....	380	ATLADM-BRFXINM66S.....	370	ATLADM-TBMEDEV4884F.....	383	ATLADM-TFBOATV3084F.....	368
ATLADM-BMTGM36108B.....	377	ATLADM-BRFXINM72S.....	370	ATLADM-TBMEDEV4884K.....	383	ATLADM-TFHRACL2454F.....	366
ATLADM-BMTGM36108C.....	377	ATLADM-BRFXINM78S.....	370	ATLADM-TBMEDEV4896F.....	383	ATLADM-TFHRACL2460F.....	366
ATLADM-BMTGM36108L.....	376	ATLADM-BRFXINM84S.....	370	ATLADM-TBMEDEV4896K.....	383	ATLADM-TFHRACL2466F.....	366
ATLADM-BMTGM36108S.....	376	ATLADM-BRFXOUTM48S.....	370	ATLADM-TBMEDEV4896K.....	383	ATLADM-TFHRACL2472F.....	366
ATLADM-BMTGM36120B.....	377	ATLADM-BRFXOUTM54S.....	370	ATLADM-TCNR45L24F.....	367	ATLADM-TFHRACL2478F.....	366
ATLADM-BMTGM36120C.....	377	ATLADM-BRFXOUTM60S.....	370	ATLADM-TCNR45L30F.....	367	ATLADM-TFHRACL2484F.....	366
ATLADM-BMTGM36120L.....	376	ATLADM-BRFXOUTM66S.....	370	ATLADM-TCNR45V24F.....	367	ATLADM-TFHRACL2484F.....	366
ATLADM-BMTGM36120S.....	376	ATLADM-BRFXOUTM72S.....	370	ATLADM-TCNR45V30F.....	367	ATLADM-TFHRACL3048F.....	366
ATLADM-BMTGM36144B.....	377	ATLADM-BRFXOUTM78S.....	370	ATLADM-TCNR90L24F.....	367	ATLADM-TFHRACL3054F.....	366
ATLADM-BMTGM36144C.....	377	ATLADM-BRFXOUTM84S.....	370	ATLADM-TCNR90L30F.....	367	ATLADM-TFHRACL3060F.....	366
ATLADM-BMTGM36144L.....	376	ATLADM-BRTLM60S.....	364	ATLADM-TCNR90V24F.....	367	ATLADM-TFHRACL3066F.....	366
ATLADM-BMTGM36144S.....	376	ATLADM-BRTLM66S.....	364	ATLADM-TCNR90V30F.....	367	ATLADM-TFHRACL3072F.....	366
ATLADM-BMTGM42108B.....	377	ATLADM-BRTLM72S.....	364	ATLADM-TCNR120L24FX.....	367	ATLADM-TFHRACL3078F.....	366
ATLADM-BMTGM42108C.....	377	ATLADM-BRTLM78S.....	364	ATLADM-TCNR120L30FX.....	367	ATLADM-TFHRACL3084F.....	366
ATLADM-BMTGM42108L.....	376	ATLADM-BRTLM84S.....	364	ATLADM-TCNR120V24FX.....	367	ATLADM-TFHRACV2448F.....	366
ATLADM-BMTGM42108S.....	376	ATLADM-BSATM2424C.....	391	ATLADM-TCNR120V30FX.....	367	ATLADM-TFHRACV2454F.....	366
ATLADM-BMTGM42120B.....	377	ATLADM-BVM4PSM5S.....	381	ATLADM-TCRRECL2048F.....	389	ATLADM-TFHRACV2460F.....	366
ATLADM-BMTGM42120C.....	377	ATLADM-BVM6PSM5S.....	381	ATLADM-TCRRECL2048K.....	389	ATLADM-TFHRACV2466F.....	366
ATLADM-BMTGM42120L.....	376	ATLADM-BVM8PSM5S.....	381	ATLADM-TCRRECL2060F.....	389	ATLADM-TFHRACV2472F.....	366
ATLADM-BMTGM42120S.....	376	ATLADM-MNWALLFL60B.....	385	ATLADM-TCRRECL2060K.....	389	ATLADM-TFHRACV2478F.....	366
ATLADM-BMTGM42144B.....	377	ATLADM-MNWALLFL60C.....	385	ATLADM-TCRRECL2072F.....	389	ATLADM-TFHRACV2484F.....	366
ATLADM-BMTGM42144C.....	377	ATLADM-MNWALLFL60L.....	385	ATLADM-TCRRECL2072K.....	389	ATLADM-TFHRACV3048F.....	366
ATLADM-BMTGM42144L.....	376	ATLADM-MNWALLFL60S.....	385	ATLADM-TCRRECL2084F.....	389	ATLADM-TFHRACV3054F.....	366
ATLADM-BMTGM42144S.....	376	ATLADM-MNWALLFV60B.....	385	ATLADM-TCRRECL2084K.....	389	ATLADM-TFHRACV3060F.....	366
ATLADM-BMTGM48108B.....	377	ATLADM-MNWALLFV60C.....	385	ATLADM-TCRRECL2096F.....	389	ATLADM-TFHRACV3066F.....	366
ATLADM-BMTGM48108C.....	377	ATLADM-MNWALLFV60L.....	385	ATLADM-TCRRECL2096K.....	389	ATLADM-TFHRACV3072F.....	366
ATLADM-BMTGM48108L.....	376	ATLADM-MNWALLFV60S.....	385	ATLADM-TCRRECV2048F.....	389	ATLADM-TFHRACV3078F.....	366
ATLADM-BMTGM48108S.....	376	ATLADM-MNWFLTFV6040.....	385	ATLADM-TCRRECV2048K.....	389	ATLADM-TFHRACV3084F.....	366
ATLADM-BMTGM48120B.....	377	ATLADM-MNWFLTFV6040.....	385	ATLADM-TCRRECV2060F.....	389	ATLADM-TFRACEL2448F.....	369
ATLADM-BMTGM48120C.....	377	ATLADM-MODL36.....	371	ATLADM-TCRRECV2060K.....	389	ATLADM-TFRACEL2448K.....	369
ATLADM-BMTGM48120L.....	376	ATLADM-MODL42.....	371	ATLADM-TCRRECV2072F.....	389	ATLADM-TFRACEL2454F.....	369
ATLADM-BMTGM48120S.....	376	ATLADM-MODL48.....	371	ATLADM-TCRRECV2072K.....	389	ATLADM-TFRACEL2454K.....	369
ATLADM-BMTGM48144B.....	377	ATLADM-MODL54.....	371	ATLADM-TCRRECV2084F.....	389	ATLADM-TFRACEL2460F.....	369
ATLADM-BMTGM48144C.....	377	ATLADM-MODL60.....	371	ATLADM-TCRRECV2084K.....	389	ATLADM-TFRACEL2460K.....	369
ATLADM-BMTGM48144L.....	376	ATLADM-MODL66.....	371	ATLADM-TCRRECV2096F.....	389	ATLADM-TFRACEL2466F.....	369
ATLADM-BMTGM48144S.....	376	ATLADM-MODL72.....	371	ATLADM-TFBOATL2460F.....	368	ATLADM-TFRACEL2466K.....	369
ATLADM-BMTGML4848B.....	380	ATLADM-MODL78.....	371	ATLADM-TFBOATL2460K.....	368	ATLADM-TFRACEL2472F.....	369
ATLADM-BMTGML4848C.....	380	ATLADM-MODL84.....	371	ATLADM-TFBOATL2466F.....	368	ATLADM-TFRACEL2472K.....	369
ATLADM-BMTGML4848S.....	380	ATLADM-MODV36.....	371	ATLADM-TFBOATL2466K.....	368	ATLADM-TFRACEL2478F.....	369
ATLADM-BMTGML5454C.....	380	ATLADM-MODV42.....	371	ATLADM-TFBOATL2472F.....	368	ATLADM-TFRACEL2478K.....	369
ATLADM-BMTGML6060B.....	380	ATLADM-MODV48.....	371	ATLADM-TFBOATL2472K.....	368	ATLADM-TFRACEL2484F.....	369
ATLADM-BMTGML6060C.....	380	ATLADM-MODV54.....	371	ATLADM-TFBOATL2478F.....	368	ATLADM-TFRACEL2484K.....	369
						ATLADM-TFRACEL3048F.....	369

INDEX

Model	Page	Model	Page	Model	Page	Model	Page
ATLADM-TFRACEL3048K	369	ATLADM-TFRRECL2454F	365	ATLADM-TMBOATL48120K	374	ATLADM-TMRACEL48120F	375
ATLADM-TFRACEL3054F	369	ATLADM-TFRRECL2460F	365	ATLADM-TMBOATL48144F	374	ATLADM-TMRACEL48120K	375
ATLADM-TFRACEL3054K	369	ATLADM-TFRRECL2466F	365	ATLADM-TMBOATL48144K	374	ATLADM-TMRACEL48144F	375
ATLADM-TFRACEL3060F	369	ATLADM-TFRRECL2472F	365	ATLADM-TMBOATV3660F	374	ATLADM-TMRACEL48144K	375
ATLADM-TFRACEL3060K	369	ATLADM-TFRRECL2478F	365	ATLADM-TMBOATV3672F	374	ATLADM-TMRACEV3660F	375
ATLADM-TFRACEL3066F	369	ATLADM-TFRRECL2484F	365	ATLADM-TMBOATV3672K	374	ATLADM-TMRACEV3660K	375
ATLADM-TFRACEL3066K	369	ATLADM-TFRRECL3048F	365	ATLADM-TMBOATV3684F	374	ATLADM-TMRACEV3672F	375
ATLADM-TFRACEL3072F	369	ATLADM-TFRRECL3054F	365	ATLADM-TMBOATV3684K	374	ATLADM-TMRACEV3672K	375
ATLADM-TFRACEL3072K	369	ATLADM-TFRRECL3060F	365	ATLADM-TMBOATV3696F	374	ATLADM-TMRACEV3684F	375
ATLADM-TFRACEL3078F	369	ATLADM-TFRRECL3066F	365	ATLADM-TMBOATV3696K	374	ATLADM-TMRACEV3684K	375
ATLADM-TFRACEL3078K	369	ATLADM-TFRRECL3072F	365	ATLADM-TMBOATV4272F	374	ATLADM-TMRACEV3696F	375
ATLADM-TFRACEV2454F	369	ATLADM-TFRRECL3078F	365	ATLADM-TMBOATV4272K	374	ATLADM-TMRACEV3696K	375
ATLADM-TFRACEV2454K	369	ATLADM-TFRRECL3084F	365	ATLADM-TMBOATV4284F	374	ATLADM-TMRACEV4272F	375
ATLADM-TFRACEV2460F	369	ATLADM-TFRRECL3084F	365	ATLADM-TMBOATV4284K	374	ATLADM-TMRACEV4272K	375
ATLADM-TFRACEV2460K	369	ATLADM-TFRRECV2448F	365	ATLADM-TMBOATV4296F	374	ATLADM-TMRACEV4284F	375
ATLADM-TFRACEV2466F	369	ATLADM-TFRRECV2454F	365	ATLADM-TMBOATV4296K	374	ATLADM-TMRACEV4284K	375
ATLADM-TFRACEV2466K	369	ATLADM-TFRRECV2460F	365	ATLADM-TMBOATV4872F	374	ATLADM-TMRACEV4296F	375
ATLADM-TFRACEV2472F	369	ATLADM-TFRRECV2466F	365	ATLADM-TMBOATV4872K	374	ATLADM-TMRACEV4296K	375
ATLADM-TFRACEV2472K	369	ATLADM-TFRRECV2478F	365	ATLADM-TMBOATV4884F	374	ATLADM-TMRACEV4872F	375
ATLADM-TFRACEV2478F	369	ATLADM-TFRRECV2484F	365	ATLADM-TMBOATV4884K	374	ATLADM-TMRACEV4872K	375
ATLADM-TFRACEV2478K	369	ATLADM-TFRRECV3048F	365	ATLADM-TMBOATV4896F	374	ATLADM-TMRACEV4884F	375
ATLADM-TFRACEV2484F	369	ATLADM-TFRRECV3054F	365	ATLADM-TMBOATV4896K	374	ATLADM-TMRACEV4884K	375
ATLADM-TFRACEV2484K	369	ATLADM-TFRRECV3060F	365	ATLADM-TMBOATV36108F	374	ATLADM-TMRACEV4896F	375
ATLADM-TFRACEV3048F	369	ATLADM-TFRRECV3066F	365	ATLADM-TMBOATV36108K	374	ATLADM-TMRACEV4896K	375
ATLADM-TFRACEV3048K	369	ATLADM-TFRRECV3072F	365	ATLADM-TMBOATV36120F	374	ATLADM-TMRACEV36108F	375
ATLADM-TFRACEV3054F	369	ATLADM-TFRRECV3078F	365	ATLADM-TMBOATV36120K	374	ATLADM-TMRACEV36108K	375
ATLADM-TFRACEV3054K	369	ATLADM-TFRRECV3084F	365	ATLADM-TMBOATV36144F	374	ATLADM-TMRACEV36120F	375
ATLADM-TFRACEV3060F	369	ATLADM-TJRRECL2436K	390	ATLADM-TMBOATV36144K	374	ATLADM-TMRACEV36120K	375
ATLADM-TFRACEV3060K	369	ATLADM-TJRRECL2442F	390	ATLADM-TMBOATV42108F	374	ATLADM-TMRACEV36144F	375
ATLADM-TFRACEV3066F	369	ATLADM-TJRRECL2442K	390	ATLADM-TMBOATV42108K	374	ATLADM-TMRACEV36144K	375
ATLADM-TFRACEV3066K	369	ATLADM-TJRRECL2448F	390	ATLADM-TMBOATV42120F	374	ATLADM-TMRACEV42108F	375
ATLADM-TFRACEV3072F	369	ATLADM-TJRRECL2448K	390	ATLADM-TMBOATV42120K	374	ATLADM-TMRACEV42120K	375
ATLADM-TFRACEV3072K	369	ATLADM-TJRRECV2436K	390	ATLADM-TMBOATV42144F	374	ATLADM-TMRACEV42120F	375
ATLADM-TFRACEV3078F	369	ATLADM-TJRRECV2436K	390	ATLADM-TMBOATV42144K	374	ATLADM-TMRACEV42120K	375
ATLADM-TFRACEV3078K	369	ATLADM-TJRRECV2442F	390	ATLADM-TMBOATV48108F	374	ATLADM-TMRACEV42144F	375
ATLADM-TFRACEV3084F	369	ATLADM-TJRRECV2442K	390	ATLADM-TMBOATV48108K	374	ATLADM-TMRACEV42144K	375
ATLADM-TFRACEV3084K	369	ATLADM-TJRRECV2448F	390	ATLADM-TMBOATV48120F	374	ATLADM-TMRACEV48108F	375
ATLADM-TFRECL2448F	365	ATLADM-TJRRECV2448K	390	ATLADM-TMBOATV48120K	374	ATLADM-TMRACEV48108K	375
ATLADM-TFRECL2454F	365	ATLADM-TMBOATL3660F	374	ATLADM-TMBOATV48144F	374	ATLADM-TMRACEV48120F	375
ATLADM-TFRECL2460F	365	ATLADM-TMBOATL3660K	374	ATLADM-TMBOATV48144K	374	ATLADM-TMRACEV48120K	375
ATLADM-TFRECL2466F	365	ATLADM-TMBOATL3672F	374	ATLADM-TMRACEL3660F	375	ATLADM-TMRACEV48144F	375
ATLADM-TFRECL2472F	365	ATLADM-TMBOATL3672K	374	ATLADM-TMRACEL3660K	375	ATLADM-TMRACEV48144K	375
ATLADM-TFRECL2478F	365	ATLADM-TMBOATL3684F	374	ATLADM-TMRACEL3672F	375	ATLADM-TMRECL3660F	372
ATLADM-TFRECL2484F	365	ATLADM-TMBOATL3684K	374	ATLADM-TMRACEL3672K	375	ATLADM-TMRECL3660K	372
ATLADM-TFRECL3048F	365	ATLADM-TMBOATL3696F	374	ATLADM-TMRACEL3684F	375	ATLADM-TMRECL3672F	372
ATLADM-TFRECL3054F	365	ATLADM-TMBOATL3696K	374	ATLADM-TMRACEL3684K	375	ATLADM-TMRECL3672K	372
ATLADM-TFRECL3060F	365	ATLADM-TMBOATL4272F	374	ATLADM-TMRACEL3696F	375	ATLADM-TMRECL3684F	372
ATLADM-TFRECL3060K	365	ATLADM-TMBOATL4272K	374	ATLADM-TMRACEL3696K	375	ATLADM-TMRECL3684K	372
ATLADM-TFRECL3066F	365	ATLADM-TMBOATL4284F	374	ATLADM-TMRACEL4272F	375	ATLADM-TMRECL3696F	372
ATLADM-TFRECL3066K	365	ATLADM-TMBOATL4284K	374	ATLADM-TMRACEL4272K	375	ATLADM-TMRECL3696K	372
ATLADM-TFRECL3072F	365	ATLADM-TMBOATL4296F	374	ATLADM-TMRACEL4284F	375	ATLADM-TMRECL4272F	372
ATLADM-TFRECL3078F	365	ATLADM-TMBOATL4296K	374	ATLADM-TMRACEL4284K	375	ATLADM-TMRECL4272K	372
ATLADM-TFRECL3084F	365	ATLADM-TMBOATL4872F	374	ATLADM-TMRACEL4296F	375	ATLADM-TMRECL4284F	372
ATLADM-TFRECL3084K	365	ATLADM-TMBOATL4872K	374	ATLADM-TMRACEL4296K	375	ATLADM-TMRECL4284K	372
ATLADM-TFRECV2448F	365	ATLADM-TMBOATL4884F	374	ATLADM-TMRACEL4872F	375	ATLADM-TMRECL4296F	372
ATLADM-TFRECV2454F	365	ATLADM-TMBOATL4884K	374	ATLADM-TMRACEL4872K	375	ATLADM-TMRECL4296K	372
ATLADM-TFRECV2460F	365	ATLADM-TMBOATL4896F	374	ATLADM-TMRACEL4884F	375	ATLADM-TMRECL4872F	372
ATLADM-TFRECV2460K	365	ATLADM-TMBOATL4896K	374	ATLADM-TMRACEL4884K	375	ATLADM-TMRECL4872K	372
ATLADM-TFRECV2472F	365	ATLADM-TMBOATL36108F	374	ATLADM-TMRACEL4896F	375	ATLADM-TMRECL4884F	372
ATLADM-TFRECV2478F	365	ATLADM-TMBOATL36108K	374	ATLADM-TMRACEL4896K	375	ATLADM-TMRECL4884K	372
ATLADM-TFRECV2484F	365	ATLADM-TMBOATL36120F	374	ATLADM-TMRACEL36108F	375	ATLADM-TMRECL4896F	372
ATLADM-TFRECV2484K	365	ATLADM-TMBOATL36120K	374	ATLADM-TMRACEL36108K	375	ATLADM-TMRECL4896K	372
ATLADM-TFRECV3048F	365	ATLADM-TMBOATL36144F	374	ATLADM-TMRACEL36120F	375	ATLADM-TMRECL36108F	372
ATLADM-TFRECV3048K	365	ATLADM-TMBOATL36144K	374	ATLADM-TMRACEL36120K	375	ATLADM-TMRECL36108K	372
ATLADM-TFRECV3066F	365	ATLADM-TMBOATL42108F	374	ATLADM-TMRACEL36144F	375	ATLADM-TMRECL36120F	372
ATLADM-TFRECV3072F	365	ATLADM-TMBOATL42108K	374	ATLADM-TMRACEL36144K	375	ATLADM-TMRECL36120K	372
ATLADM-TFRECV3078F	365	ATLADM-TMBOATL42120F	374	ATLADM-TMRACEL42108F	375	ATLADM-TMRECL36144F	372
ATLADM-TFRECV3084F	365	ATLADM-TMBOATL42120K	374	ATLADM-TMRACEL42108K	375	ATLADM-TMRECL36144K	372
ATLADM-TFRNDL96F	382	ATLADM-TMBOATL42144F	374	ATLADM-TMRACEL42120F	375	ATLADM-TMRECL42108F	372
ATLADM-TFRNDL96K	382	ATLADM-TMBOATL42144K	374	ATLADM-TMRACEL42120K	375	ATLADM-TMRECL42108K	372
ATLADM-TFRNDV96F	382	ATLADM-TMBOATL48108F	374	ATLADM-TMRACEL42144F	375	ATLADM-TMRECL42120F	372
ATLADM-TFRNDV96K	382	ATLADM-TMBOATL48108K	374	ATLADM-TMRACEL42144K	375	ATLADM-TMRECL42120K	372
ATLADM-TFRRECL2448F	365	ATLADM-TMBOATL48120F	374	ATLADM-TMRACEL48108F	375	ATLADM-TMRECL42144F	372
				ATLADM-TMRACEL48108K	375	ATLADM-TMRECL42144K	372

Cross Reference Index

by Model Number

Model	Page	Model	Page	Model	Page	Model	Page
ATLADM-TMRECL48108F.....	372	ATLADM-TMRRECL4284F.....	373	ATLADM-TMRSQRL60F.....	379	ATLADM-TPRRECL2060F.....	387
ATLADM-TMRECL48108K.....	372	ATLADM-TMRRECL4284K.....	373	ATLADM-TMRSQRL60K.....	379	ATLADM-TPRRECL2060K.....	387
ATLADM-TMRECL48120F.....	372	ATLADM-TMRRECL4296F.....	373	ATLADM-TMRSQRV36F.....	379	ATLADM-TPRRECL2072F.....	387
ATLADM-TMRECL48120K.....	372	ATLADM-TMRRECL4296K.....	373	ATLADM-TMRSQRV36K.....	379	ATLADM-TPRRECL2072K.....	387
ATLADM-TMRECL48144F.....	372	ATLADM-TMRRECL4872F.....	373	ATLADM-TMRSQRV42F.....	379	ATLADM-TPRRECL2084F.....	387
ATLADM-TMRECL48144K.....	372	ATLADM-TMRRECL4872K.....	373	ATLADM-TMRSQRV42K.....	379	ATLADM-TPRRECL2084K.....	387
ATLADM-TMRECV3660F.....	372	ATLADM-TMRRECL4884F.....	373	ATLADM-TMRSQRV48F.....	379	ATLADM-TPRRECL2096F.....	387
ATLADM-TMRECV3660K.....	372	ATLADM-TMRRECL4884K.....	373	ATLADM-TMRSQRV48K.....	379	ATLADM-TPRRECL2096K.....	387
ATLADM-TMRECV3672F.....	372	ATLADM-TMRRECL4896F.....	373	ATLADM-TMRSQRV54F.....	379	ATLADM-TPRRECV2048F.....	387
ATLADM-TMRECV3672K.....	372	ATLADM-TMRRECL4896K.....	373	ATLADM-TMRSQRV54K.....	379	ATLADM-TPRRECV2048K.....	387
ATLADM-TMRECV3684F.....	372	ATLADM-TMRRECL36108F.....	373	ATLADM-TMRSQRV60F.....	379	ATLADM-TPRRECV2060F.....	387
ATLADM-TMRECV3684K.....	372	ATLADM-TMRRECL36108K.....	373	ATLADM-TMRSQRV60K.....	379	ATLADM-TPRRECV2060K.....	387
ATLADM-TMRECV3696F.....	372	ATLADM-TMRRECL36120F.....	373	ATLADM-TMSQRL36F.....	378	ATLADM-TPRRECV2072F.....	387
ATLADM-TMRECV3696K.....	372	ATLADM-TMRRECL36120K.....	373	ATLADM-TMSQRL36K.....	378	ATLADM-TPRRECV2072K.....	387
ATLADM-TMRECV4272F.....	372	ATLADM-TMRRECL36144F.....	373	ATLADM-TMSQRL42F.....	378	ATLADM-TPRRECV2084F.....	387
ATLADM-TMRECV4272K.....	372	ATLADM-TMRRECL36144K.....	373	ATLADM-TMSQRL42K.....	378	ATLADM-TPRRECV2084K.....	387
ATLADM-TMRECV4284F.....	372	ATLADM-TMRRECL42108F.....	373	ATLADM-TMSQRL48F.....	378	ATLADM-TPRRECV2096F.....	387
ATLADM-TMRECV4284K.....	372	ATLADM-TMRRECL42108K.....	373	ATLADM-TMSQRL48K.....	378	ATLADM-TPRRECV2096K.....	387
ATLADM-TMRECV4296F.....	372	ATLADM-TMRRECL42120F.....	373	ATLADM-TMSQRL54F.....	378	ATLADM-TRMEDL4848F.....	383
ATLADM-TMRECV4296K.....	372	ATLADM-TMRRECL42120K.....	373	ATLADM-TMSQRL54K.....	378	ATLADM-TRMEDL4848K.....	383
ATLADM-TMRECV4872F.....	372	ATLADM-TMRRECL42144F.....	373	ATLADM-TMSQRL60F.....	378	ATLADM-TRMEDL4860F.....	383
ATLADM-TMRECV4872K.....	372	ATLADM-TMRRECL42144K.....	373	ATLADM-TMSQRL60K.....	378	ATLADM-TRMEDL4860K.....	383
ATLADM-TMRECV4884F.....	372	ATLADM-TMRRECL48108F.....	373	ATLADM-TMSQRL60K.....	378	ATLADM-TRMEDL4860F.....	383
ATLADM-TMRECV4884K.....	372	ATLADM-TMRRECL48108K.....	373	ATLADM-TMSQRV36F.....	378	ATLADM-TRMEDL4872F.....	383
ATLADM-TMRECV4896F.....	372	ATLADM-TMRRECL48120F.....	373	ATLADM-TMSQRV36K.....	378	ATLADM-TRMEDL4872K.....	383
ATLADM-TMRECV4896K.....	372	ATLADM-TMRRECL48120K.....	373	ATLADM-TMSQRV42F.....	378	ATLADM-TRMEDL4884F.....	383
ATLADM-TMRECV4896F.....	372	ATLADM-TMRRECL48120K.....	373	ATLADM-TMSQRV42K.....	378	ATLADM-TRMEDL4884K.....	383
ATLADM-TMRECV36108F.....	372	ATLADM-TMRRECL48144F.....	373	ATLADM-TMSQRV48F.....	378	ATLADM-TRMEDL4896F.....	383
ATLADM-TMRECV36108K.....	372	ATLADM-TMRRECL48144K.....	373	ATLADM-TMSQRV48K.....	378	ATLADM-TRMEDL4896K.....	383
ATLADM-TMRECV36120F.....	372	ATLADM-TMRRECV3660F.....	373	ATLADM-TMSQRV54F.....	378	ATLADM-TRMEDV4848F.....	383
ATLADM-TMRECV36120K.....	372	ATLADM-TMRRECV3660K.....	373	ATLADM-TMSQRV54K.....	378	ATLADM-TRMEDV4848K.....	383
ATLADM-TMRECV36144F.....	372	ATLADM-TMRRECV3672F.....	373	ATLADM-TMSQRV60F.....	378	ATLADM-TRMEDV4860F.....	383
ATLADM-TMRECV36144K.....	372	ATLADM-TMRRECV3672K.....	373	ATLADM-TMSQRV60K.....	378	ATLADM-TRMEDV4860K.....	383
ATLADM-TMRECV42108F.....	372	ATLADM-TMRRECV3684F.....	373	ATLADM-TMSSQRL36F.....	379	ATLADM-TRMEDV4872F.....	383
ATLADM-TMRECV42108K.....	372	ATLADM-TMRRECV3684K.....	373	ATLADM-TMSSQRL36K.....	379	ATLADM-TRMEDV4872K.....	383
ATLADM-TMRECV42120F.....	372	ATLADM-TMRRECV3696F.....	373	ATLADM-TMSSQRL42F.....	379	ATLADM-TRMEDV4884F.....	383
ATLADM-TMRECV42120K.....	372	ATLADM-TMRRECV3696K.....	373	ATLADM-TMSSQRL42K.....	379	ATLADM-TRMEDV4884K.....	383
ATLADM-TMRECV42144F.....	372	ATLADM-TMRRECV4272F.....	373	ATLADM-TMSSQRL48F.....	379	ATLADM-TRMEDV4896F.....	383
ATLADM-TMRECV42144K.....	372	ATLADM-TMRRECV4272K.....	373	ATLADM-TMSSQRL48K.....	379	ATLADM-TRMEDV4896K.....	383
ATLADM-TMRECV48108F.....	372	ATLADM-TMRRECV4284F.....	373	ATLADM-TMSSQRL54F.....	379	ATLADM-TSSQRL24F.....	391
ATLADM-TMRECV48108K.....	372	ATLADM-TMRRECV4284K.....	373	ATLADM-TMSSQRL54K.....	379	ATLADM-TSSQRL24K.....	391
ATLADM-TMRECV48120F.....	372	ATLADM-TMRRECV4296F.....	373	ATLADM-TMSSQRL60F.....	379	ATLADM-TSSQRV24F.....	391
ATLADM-TMRECV48120K.....	372	ATLADM-TMRRECV4296K.....	373	ATLADM-TMSSQRL60K.....	379	ATLADM-TSSQRV24K.....	391
ATLADM-TMRECV48144F.....	372	ATLADM-TMRRECV4872F.....	373	ATLADM-TMSSQRV36F.....	379	ATLADM-TTRECL2460F.....	364
ATLADM-TMRECV48144K.....	372	ATLADM-TMRRECV4872K.....	373	ATLADM-TMSSQRV36K.....	379	ATLADM-TTRECL2466F.....	364
ATLADM-TMRNDL36F.....	378	ATLADM-TMRRECV4884F.....	373	ATLADM-TMSSQRV42F.....	379	ATLADM-TTRECL2472F.....	364
ATLADM-TMRNDL36K.....	378	ATLADM-TMRRECV4884K.....	373	ATLADM-TMSSQRV42K.....	379	ATLADM-TTRECL2478F.....	364
ATLADM-TMRNDL42F.....	378	ATLADM-TMRRECV4896F.....	373	ATLADM-TMSSQRV48F.....	379	ATLADM-TTRECL2484F.....	364
ATLADM-TMRNDL42K.....	378	ATLADM-TMRRECV4896K.....	373	ATLADM-TMSSQRV48K.....	379	ATLADM-TTRECL2484K.....	364
ATLADM-TMRNDL48F.....	378	ATLADM-TMRRECV36108F.....	373	ATLADM-TMSSQRV54F.....	379	ATLADM-TTRECL3060F.....	364
ATLADM-TMRNDL48K.....	378	ATLADM-TMRRECV36108K.....	373	ATLADM-TMSSQRV54K.....	379	ATLADM-TTRECL3066F.....	364
ATLADM-TMRNDL54F.....	378	ATLADM-TMRRECV36120F.....	373	ATLADM-TMSSQRV60F.....	379	ATLADM-TTRECL3072F.....	364
ATLADM-TMRNDL54K.....	378	ATLADM-TMRRECV36120K.....	373	ATLADM-TMSSQRV60K.....	379	ATLADM-TTRECL3078F.....	364
ATLADM-TMRNDL60F.....	378	ATLADM-TMRRECV36144F.....	373	ATLADM-TMSSQRV60K.....	379	ATLADM-TTRECL3084F.....	364
ATLADM-TMRNDL60K.....	378	ATLADM-TMRRECV36144K.....	373	ATLADM-TPRACEL2048F.....	387	ATLADM-TTRECV2460F.....	364
ATLADM-TMRNDV36F.....	378	ATLADM-TMRRECV42108F.....	373	ATLADM-TPRACEL2048K.....	387	ATLADM-TTRECV2466F.....	364
ATLADM-TMRNDV36K.....	378	ATLADM-TMRRECV42108K.....	373	ATLADM-TPRACEL2060F.....	387	ATLADM-TTRECV2472F.....	364
ATLADM-TMRNDV42F.....	378	ATLADM-TMRRECV42120F.....	373	ATLADM-TPRACEL2060K.....	387	ATLADM-TTRECV2478F.....	364
ATLADM-TMRNDV42K.....	378	ATLADM-TMRRECV42120K.....	373	ATLADM-TPRACEL2072F.....	387	ATLADM-TTRECV2484F.....	364
ATLADM-TMRNDV48F.....	378	ATLADM-TMRRECV42144F.....	373	ATLADM-TPRACEL2072K.....	387	ATLADM-TTRECV3060F.....	364
ATLADM-TMRNDV48K.....	378	ATLADM-TMRRECV42144K.....	373	ATLADM-TPRACEL2084F.....	387	ATLADM-TTRECV3066F.....	364
ATLADM-TMRNDV54F.....	378	ATLADM-TMRRECV48108F.....	373	ATLADM-TPRACEL2084K.....	387	ATLADM-TTRECV3072F.....	364
ATLADM-TMRNDV54K.....	378	ATLADM-TMRRECV48108K.....	373	ATLADM-TPRACEL2096F.....	387	ATLADM-TTRECV3078F.....	364
ATLADM-TMRNDV60F.....	378	ATLADM-TMRRECV48120F.....	373	ATLADM-TPRACEL2096K.....	387	ATLADM-TTRECV3084F.....	364
ATLADM-TMRNDV60K.....	378	ATLADM-TMRRECV48120K.....	373	ATLADM-TPRACEL2096K.....	387	ATLADM-TTRECV3084F.....	364
ATLADM-TMRRECL3660F.....	373	ATLADM-TMRRECV48144F.....	373	ATLADM-TPRACEV2048F.....	387	ATLADM-TTRECV2460F.....	364
ATLADM-TMRRECL3660K.....	373	ATLADM-TMRRECV48144K.....	373	ATLADM-TPRACEV2048K.....	387	ATLADM-TTRECV2466F.....	364
ATLADM-TMRRECL3672F.....	373	ATLADM-TMRSQRL36F.....	379	ATLADM-TPRACEV2060F.....	387	ATLADM-TTRECV2472F.....	364
ATLADM-TMRRECL3672K.....	373	ATLADM-TMRSQRL36K.....	379	ATLADM-TPRACEV2060K.....	387	ATLADM-TTRECV2478F.....	364
ATLADM-TMRRECL3684F.....	373	ATLADM-TMRSQRL42F.....	379	ATLADM-TPRACEV2072F.....	387	ATLADM-TTRECV2484F.....	364
ATLADM-TMRRECL3684K.....	373	ATLADM-TMRSQRL42K.....	379	ATLADM-TPRACEV2072K.....	387	ATLADM-TTRECV3060F.....	364
ATLADM-TMRRECL3696F.....	373	ATLADM-TMRSQRL48F.....	379	ATLADM-TPRACEV2084F.....	387	ATLADM-TTRECV3066F.....	364
ATLADM-TMRRECL3696K.....	373	ATLADM-TMRSQRL48K.....	379	ATLADM-TPRACEV2084K.....	387	ATLADM-TTRECV3072F.....	364
ATLADM-TMRRECL4272F.....	373	ATLADM-TMRSQRL54F.....	379	ATLADM-TPRACEV2096F.....	387	ATLADM-TTRECV3078F.....	364
ATLADM-TMRRECL4272K.....	373	ATLADM-TMRSQRL54K.....	379	ATLADM-TPRACEV2096K.....	387	ATLADM-TTRECV3084F.....	364
				ATLADM-TPRRECL2048F.....	387	ATLADM-TTRECV2460F.....	364
				ATLADM-TPRRECL2048K.....	387	ATLADM-TTRECV2466F.....	364

INDEX

Model	Page	Model	Page	Model	Page	Model	Page
ATLADM-TTRRECV2472F	364	AW2TL30N54CS	474, 480, 482	AW2TS24N66CS	472	AW2VMPCS	470, 474, 480, 482
ATLADM-TTRRECV2478F	364	AW2TL30N60CB	476	AW2TS24N72CB	472	AW2VMPCS60	472, 476
ATLADM-TTRRECV2484F	364	AW2TL30N60CS	476	AW2TS24N72CS	472	AW2VMPCS72	472, 476
ATLADM-TTRRECV3060F	364	AW2TL30N66CB	476	AW2TS24N84CB	472	AW2VMPCS84	472, 476
ATLADM-TTRRECV3066F	364	AW2TL30N66CS	476	AW2TS24N84CS	472	AW2VMPCS96	472, 476
ATLADM-TTRRECV3072F	364	AW2TL30N72CB	476	AW2TS24N96CB	472	AW2VMPGB	470, 474, 480, 482
ATLADM-TTRRECV3078F	364	AW2TL30N72CS	476	AW2TS24N96CS	472	AW2VMPGB60	472, 476
ATLADM-TTRRECV3084F	364	AW2TL30N84CB	476	AW2TSFCB	466	AW2VMPGB72	472, 476
ATLADM-TVM15L4PF	381	AW2TL30N84CS	476	AW2TSFCS	466	AW2VMPGB84	472, 476
ATLADM-TVM15L4PK	381	AW2TL30N96CB	476	AW2TSFGB	466	AW2VMPGB96	472, 476
ATLADM-TVM15L6PF	381	AW2TL30N96CS	476	AW2TSFGS	466	AW2VMPGS	470, 474, 480, 482
ATLADM-TVM15L6PK	381	AW2TL36N48CB	478, 482	AW2TSPCB	468, 470, 480	AW2VMPGS60	472, 476
ATLADM-TVM15L8PF	381	AW2TL36N48CS	478, 482	AW2TSPCB60	468, 472	AW2VMPGS72	472, 476
ATLADM-TVM15L8PK	381	AW2TL36N54CB	478	AW2TSPCB72	468, 472	AW2VMPGS84	472, 476
ATLADM-TVM15V4PF	381	AW2TL36N54CS	478	AW2TSPCB84	472	AW2VMPGS96	472, 476
ATLADM-TVM15V4PK	381	AW2TL36N60CB	478	AW2TSPCB96	472	AW2VMSHCB	470
ATLADM-TVM15V6PF	381	AW2TL36N60CS	478	AW2TSPCS	468, 470, 480	AW2VMSHCB60	472
ATLADM-TVM15V6PK	381	AW2TL36N66CB	478	AW2TSPCS60	468, 472	AW2VMSHCB72	472
ATLADM-TVM15V8PF	381	AW2TL36N66CS	478	AW2TSPCS72	468, 472	AW2VMSHCB84	472
ATLADM-TVM15V8PK	381	AW2TL36N72CB	478	AW2TSPCS84	472	AW2VMSHGB	470
ATLADM-TVM30L4PF	381	AW2TL36N72CS	478	AW2TSPCS96	472	AW2VMSHGB60	472
ATLADM-TVM30L4PK	381	AW2TLFCB	466	AW2TSPGB	468, 470, 480	AW2VMSHGB72	472
ATLADM-TVM30L6PF	381	AW2TLFCS	466	AW2TSPGB60	468, 472	AW2VMSHGB84	472
ATLADM-TVM30L6PK	381	AW2TLFGB	466	AW2TSPGB72	468, 472	AW3FE1848T	467
ATLADM-TVM30L8PF	381	AW2TLFGS	466	AW2TSPGB84	472	AW3FE1854T	467
ATLADM-TVM30L8PK	381	AW2TLPCB	474, 478, 480, 482	AW2TSPGB96	472	AW3FE1860F	465
ATLADM-TVM30V4PF	381	AW2TLPCB60	476, 478	AW2TSPGS	468, 470, 480	AW3FE1860T	467
ATLADM-TVM30V4PK	381	AW2TLPCB72	476, 478	AW2TSPGS60	468, 472	AW3FE1866F	465
ATLADM-TVM30V6PF	381	AW2TLPCB84	476	AW2TSPGS72	468, 472	AW3FE1866T	467
ATLADM-TVM30V6PK	381	AW2TLPCB96	476	AW2TSPGS84	472	AW3FE1872F	465
ATLADM-TVM30V8PF	381	AW2TLPCS	474, 478, 480, 482	AW2TSPGS96	472	AW3FE1872T	467
ATLADM-TVM30V8PK	381	AW2TLPCS60	476, 478	AW2VM18N42CB	482	AW3FE2436T	469
ATLADM-TVM55L4PF	381	AW2TLPCS72	476, 478	AW2VM18N42CS	482	AW3FE2436V	469
ATLADM-TVM55L4PK	381	AW2TLPCS84	476	AW2VM24N36CB	470	AW3FE2442T	469
ATLADM-TVM55L6PF	381	AW2TLPCS96	476	AW2VM24N36CS	470	AW3FE2442V	469
ATLADM-TVM55L6PK	381	AW2TLPGB	474, 478, 480, 482	AW2VM24N42CB	470, 480	AW3FE2448T	469
ATLADM-TVM55L8PF	381	AW2TLPGB60	476, 478	AW2VM24N42CS	470, 480	AW3FE2448V	469
ATLADM-TVM55L8PK	381	AW2TLPGB72	476, 478	AW2VM24N48CB	470	AW3FE2454T	469
ATLADM-TVM55V4PF	381	AW2TLPGB84	476	AW2VM24N48CS	470	AW3FE2454V	469
ATLADM-TVM55V4PK	381	AW2TLPGB96	476	AW2VM24N54CB	470	AW3FE2460F	465
ATLADM-TVM55V6PF	381	AW2TLPGB96	476	AW2VM24N54CS	470	AW3FE2460T	471
ATLADM-TVM55V6PK	381	AW2TLPGB96	476	AW2VM24N60CB	472	AW3FE2460V	471
ATLADM-TVM55V8PF	381	AW2TLPGB96	476	AW2VM24N60CS	472	AW3FE2466F	465
ATLADM-TVM55V8PK	381	AW2TLPGB96	476	AW2VM24N66CB	472	AW3FE2466T	471
ATPCIF48	200	AW2TLPGB96	476	AW2VM24N66CS	472	AW3FE2466V	471
ATPCIF72	200	AW2TLPCB	474, 478, 480, 482	AW2VM24N72CB	472	AW3FE2472F	465
ATPHWIF72	200	AW2TLPCB60	476, 478	AW2VM24N72CS	472	AW3FE2472T	471
ATPKIT48	200	AW2TLPCB72	476, 478	AW2VM24N84CB	472	AW3FE2472V	471
ATPKIT60	200	AW2TLPCB84	476	AW2VM24N84CS	472	AW3FE2484T	471
ATPKIT72	200	AW2TLPCB96	476	AW2VM24N96CB	472	AW3FE2484V	471
ATPKIT482	200	AW2TLPCB96	476	AW2VM24N96CS	472	AW3FE2496T	471
ATPKIT602	200	AW2TLPCB96	476	AW2VM30N36CB	474	AW3FE2496V	471
ATPKIT722	200	AW2TLPCB96	476	AW2VM30N36CS	474	AW3FE3036T	473
ATPSPLIT	200	AW2TLPCB96	476	AW2VM30N42CB	474, 482	AW3FE3036V	473
AUPWRMOD	200, 395, 453	AW2TLPCB96	476	AW2VM30N42CS	474, 482	AW3FE3042T	473
AURNDPWRMOD	200, 453	AW2TLPCB96	476	AW2VM30N48CB	474, 480	AW3FE3042V	473
AVF5RS4824	424	AW2TLPCB96	476	AW2VM30N48CS	474, 480	AW3FE3048T	473
AVF5RS4830	424	AW2TLPCB96	476	AW2VM30N54CB	474	AW3FE3048V	473
AVF5RS5424	424	AW2TLPCB96	476	AW2VM30N54CS	474	AW3FE3054T	473
AVF5RS5430	424	AW2TLPCB96	476	AW2VM30N60CB	476	AW3FE3054V	473
AVF5RS6024D	424	AW2TLPCB96	476	AW2VM30N60CS	476	AW3FE3060F	465
AVF5RS6030D	424	AW2TLPCB96	476	AW2VM30N66CB	476	AW3FE3060T	475
AVF5RS6624D	424	AW2TLPCB96	476	AW2VM30N66CS	476	AW3FE3060V	475
AVF5RS6630D	424	AW2TLPCB96	476	AW2VM30N72CB	476	AW3FE3066F	465
AVF5RS7224D	424	AW2TLPCB96	476	AW2VM30N72CS	476	AW3FE3066T	475
AVF5RS7230D	424	AW2TLPCB96	476	AW2VM30N84CB	476	AW3FE3066V	475
AVSTA3PWR	453, 1	AW2TLPCB96	476	AW2VM30N84CS	476	AW3FE3072F	465
AW2TL30N36CB	474	AW2TLPCB96	476	AW2VM30N86CS	476	AW3FE3072T	475
AW2TL30N36CS	474	AW2TLPCB96	476	AW2VM30N96CB	476	AW3FE3072V	475
AW2TL30N42CB	474	AW2TLPCB96	476	AW2VMPCB	470, 474, 480, 482	AW3FE3084T	475
AW2TL30N42CS	474	AW2TLPCB96	476	AW2VMPCB60	472, 476	AW3FE3084V	475
AW2TL30N48CB	474	AW2TLPCB96	476	AW2VMPCB72	472, 476	AW3FE3096T	475
AW2TL30N48CS	474	AW2TLPCB96	476	AW2VMPCB84	472, 476	AW3FE3096V	475
AW2TL30N54CB	474, 480, 482	AW2TLPCB96	476	AW2VMPCB96	472, 476	AW3FE3648T	477

Cross Reference Index

by Model Number

Model	Page	Model	Page	Model	Page	Model	Page
AW3FE3654T	477	AW3LK2448V	469	AW3LTH2448V	479	AW4HM78	483
AW3FE3660T	477	AW3LK2454V	469	AW3LTH3060T	479	AW4HM84	483
AW3FE3666T	477	AW3LK2460V	471	AW3LTH3060V	479	AW4HM90	483
AW3FE3672T	477	AW3LK2466V	471	AW3LTH3672T	479	AW4HM96	483
AW3LF1848T	467	AW3LK2472V	471	AW3LTP2455V	481	AW4LECT	491
AW3LF1854T	467	AW3LK2484V	471	AW3LTP3066T	481	AW4LECTPWR	491
AW3LF1860F	465	AW3LK2496V	471	AW3LTQ2490	481	AW4MB5036G	489
AW3LF1860T	467	AW3LK3036V	473	AW3LTQ3090	481	AW4MB5036P	489
AW3LF1866F	465	AW3LK3042V	473	AW3LTT2460T	479	AW4MB5048G	489
AW3LF1866T	467	AW3LK3048V	473	AW3LTT3072V	479	AW4MB5048P	489
AW3LF1872F	465	AW3LK3054V	473	AW3VF1848T	467	AW4MB7236G	489
AW3LF1872T	467	AW3LK3060V	475	AW3VF1854T	467	AW4MB7236P	489
AW3LF2436T	469	AW3LK3066V	475	AW3VF1860T	467	AW4MB7248G	489
AW3LF2436V	469	AW3LK3072V	475	AW3VF1866T	467	AW4MB7248P	489
AW3LF2442T	469	AW3LK3084V	475	AW3VF1872T	467	AW4MB7260P	489
AW3LF2442V	469	AW3LK3096V	475	AW3VF2436T	469	AW4P2C	485, 553
AW3LF2448T	469	AW3LT1848T	467	AW3VF2436V	469	AW4P2H	485, 552
AW3LF2448V	469	AW3LT1854T	467	AW3VF2442T	469	AW4QBCJ36	485
AW3LF2454T	469	AW3LT1860F	465	AW3VF2442V	469	AW4QBI	394, 485, 554
AW3LF2454V	469	AW3LT1860T	467	AW3VF2448T	469	AW4QH60P	485
AW3LF2460F	465	AW3LT1866F	465	AW3VF2448V	469	AW4QJ36	394, 485
AW3LF2460T	471	AW3LT1866T	467	AW3VF2454T	469	AW4SHELFL	487
AW3LF2460V	471	AW3LT1872F	465	AW3VF2454V	469	AW4TB5036	489
AW3LF2466F	465	AW3LT1872T	467	AW3VF2460T	471	AW4TB5048	489
AW3LF2466T	471	AW3LT2436T	469	AW3VF2460V	471	AW4TB7236	489
AW3LF2466V	471	AW3LT2436V	469	AW3VF2466T	471	AW4TB7248	489
AW3LF2472F	465	AW3LT2442T	469	AW3VF2466V	471	AW4TB7260	489
AW3LF2472T	471	AW3LT2442V	469	AW3VF2472T	471	AW4TRASH	487
AW3LF2472V	471	AW3LT2448T	469	AW3VF2472V	471	AW4W48	485
AW3LF2484T	471	AW3LT2448V	469	AW3VF2484T	471	AW4W60	485
AW3LF2484V	471	AW3LT2454T	469	AW3VF2484V	471	AW4W72	485
AW3LF2496T	471	AW3LT2454V	469	AW3VF2496T	471	AW4W84	485
AW3LF2496V	471	AW3LT2460F	465	AW3VF2496V	471	AW4WB3648G	490
AW3LF3036T	473	AW3LT2460T	471	AW3VF3036T	473	AW4WB3648P	490
AW3LF3036V	473	AW3LT2460V	471	AW3VF3036V	473	AW4WB4848G	490
AW3LF3042T	473	AW3LT2466F	465	AW3VF3042T	473	AW4WB4848P	490
AW3LF3042V	473	AW3LT2466T	471	AW3VF3042V	473	AW4WB4860G	490
AW3LF3048T	473	AW3LT2466V	471	AW3VF3048T	473	AW4WB4860P	490
AW3LF3048V	473	AW3LT2472F	465	AW3VF3048V	473	AW4WB4872G	490
AW3LF3054T	473	AW3LT2472T	471	AW3VF3054T	473	AW4WB4872P	490
AW3LF3054V	473	AW3LT2472V	471	AW3VF3054V	473	AW4WB4896G	490
AW3LF3060F	465	AW3LT2484T	471	AW3VF3060T	475	AW4WB4896P	490
AW3LF3060T	475	AW3LT2484V	471	AW3VF3060V	475	AW4WC36LABEL	488
AW3LF3060V	475	AW3LT2496T	471	AW3VF3066T	475	AW4WC57LABEL	488
AW3LF3066F	465	AW3LT2496V	471	AW3VF3066V	475	AW4WC3620	488
AW3LF3066T	475	AW3LT3036T	473	AW3VF3072T	475	AW4WC5720	488
AW3LF3066V	475	AW3LT3036V	473	AW3VF3072V	475	AW4WCTIBC36W	488
AW3LF3072F	465	AW3LT3042T	473	AW3VF3084T	475	AW4WCTIBC57W	488
AW3LF3072T	475	AW3LT3042V	473	AW3VF3084V	475	AW4WCTIP36W	488
AW3LF3072V	475	AW3LT3048T	473	AW3VF3096T	475	AW4WCTIP57W	488
AW3LF3084T	475	AW3LT3048V	473	AW3VF3096V	475	AWCS	442
AW3LF3084V	475	AW3LT3054T	473	AW3VF3648T	477	AWCVRCL	485
AW3LF3096T	475	AW3LT3054V	473	AW3VF3654T	477	AWCVRG	485
AW3LF3096V	475	AW3LT3060F	465	AW3VF3660T	477	AWIRECLT	427, 453, 2
AW3LF3648T	477	AW3LT3060T	475	AW3VF3666T	477	AWLG	50
AW3LF3654T	477	AW3LT3060V	475	AW3VF3672T	477	AWLP	50
AW3LF3660T	477	AW3LT3066F	465	AW4AVRACK	487	AWLS	50
AW3LF3666T	477	AW3LT3066T	475	AW4BACC	489, 490	AWLW	50
AW3LF3672T	477	AW3LT3066V	475	AW4BC4824L	487	AWMG	50
AW3LFC2470V	481	AW3LT3072F	465	AW4BC4824LNG	487	AWMP	50
AW3LFC3085T	481	AW3LT3072T	475	AW4BC4824R	487	AWMS	50
AW3LFH2448T	479	AW3LT3072V	475	AW4BC4824RNG	487	AWMW	50
AW3LFH2448V	479	AW3LT3084T	475	AW4BC7224	487	AWRSTRIP	427, 453.2, 551.1
AW3LFH3060T	479	AW3LT3084V	475	AW4BC7224NG	487	BP4UC	184
AW3LFH3060V	479	AW3LT3096T	475	AW4BHOOK	489	BPBSCR24	190
AW3LFH3672T	479	AW3LT3096V	475	AW4DRAWER	487	BPBSCR30	180
AW3LFP2455V	481	AW3LT3648T	477	AW4GANG	394, 483, 554	BPBSCR36	190
AW3LFP3066T	481	AW3LT3654T	477	AW4HM36	483	BPBSCR45	180
AW3LFPQ2490	481	AW3LT3660T	477	AW4HM42	483	BPCCT24	192
AW3LFPQ3090	481	AW3LT3666T	477	AW4HM48	483	BPCT24	182
AW3LFT2460T	479	AW3LT3672T	477	AW4HM54	483	BPCH	196
AW3LFT3072V	479	AW3LTC2470V	481	AW4HM60	483	BPCT12	192
AW3LK2436V	469	AW3LTC3085T	481	AW4HM66	483	BPCT15	182
AW3LK2442V	469	AW3LTH2448T	479	AW4HM72	483	BPCT24	192

Cross Reference Index

by Model Number

Model	Page	Model	Page	Model	Page	Model	Page
BPCT30	182	BSSICC	196	CWSS30U-PPGA	100	EPP1820S	280
BPCT2445	196	C5OMFC	58	CWSU-PPGA	100	EPP2128HM	282
BPCTO24	192	CBW-MHA	88	CWSU-PPGO	100	EPP2128HS	280
BPCTO30	182	CBW-MHF	88	CWW-MHA	88	EPP2128M	282
BPLB	180	CBW-MHH	88	CWW-MHF	88	EPP2128S	280
BPLBL	180	CBW-MHW	88	CWW-MHH	88	EPR18HM	282
BPLBR	180	CBW-MMA	88	CWW-MHW	88	EPR18HS	280
BPLCM	178	CBW-MMF	88	CWW-MMA	88	EPR18M	282
BPLCPL	184	CBW-MMH	88	CWW-MMF	88	EPR18S	280
BPLCR	180	CBW-MMW	88	CWW-MMH	88	EPW18HM	282
BPLCRPL	184	CFDPWRC	427.1	CWW-MMW	88	EPW18HS	280
BPLCS	176	CFDPWRSC	427.1	DSC-MUCONO	65	EPW18M	282
BPLEL	184	C-HDRK	88, 90	DSC-MUGONO	65	EPW18S	280
BPLELC	184	CHULNO	295	DWC-UMANO	62	ET20	286, 332
BPLLM	178	CLCCNO	272	DWC-UMFNO	62	ET39	286, 332
BPLLS	176	CLCNO	272	DWC-UMHNO	62	ET1421	286, 332
BPLO	180	CLCPCNO	272	DWC-UMWNO	62	ET2142	286, 332
BPLRM	178	CLCPNO	272	DW-LUK	62	ET4242	286, 332
BPLRS	176	CLG-CGANO	292	DWS-MHANO	64	EV20	288, 334
BPLSIC	184	CLG-UGANO	292	DWS-MHFNO	64	EV39	288, 334
BPLSIL	184	CLG-WGANO	292	DWS-MHHNO	64	EV1421	288, 334
BPLSIL15	184	CLL-MLA	93	DWS-MHWNO	64	EV2142	288, 334
BPLSIL30	184	CLL-MLF	93	DWW-MHANO	62	EV4242	288, 334
BPLSM	178	CLL-MLH	93	DWW-MHFNO	62	FDEPC2	434
BPLSNM	178	CLR-CGANO	293	DWW-MHHNO	62	FDEPC12	434
BPLSNS	176	CLR-UGANO	293	DWW-MHWNO	62	FDPWRC	427.1
BPLSO	180	CLR-WGANO	293	EAAC	447	FDPWRSC	427.1
BPLSPL	184	CLSCNO	272	EABS	447	FDRWEC	434
BPLSS	176	CLSNO	272	EACS	447	FDRWLEG	434
BPLSWM	178	CMPN-PPCA	100	EADH	447	FDRWUC	434
BPLSWS	176	CMPN-PPCO	100	EAFS	447	FDSC48LL	431
BPLTL	180	CMPN-PPGA	100	EAFU	447	FDSC48LR	431
BPLTR	180	CMPN-PPGO	100	EAHSR36	446	FDSC48R	431
BPNT12	192	CMPNU-PPCA	100	EAHSR42	446	FDSC48U	431
BPNT15	182	CMPNU-PPCO	100	EAHSR48	446	FDSC54LL	431
BPNT24	192	CMPNU-PPGA	100	EAHSR60	446	FDSC54LR	431
BPNT30	182	CMPNU-PPGO	100	EAHSR66	446	FDSC54R	431
BPSIC15	196	CMPW-PPCANO	97	EAHSR72	446	FDSC54U	431
BPSIC30	196	CMPW-PPCONO	97	EAPS	447	FDSC60LL	431
BPTE24	192	CMPWU-PPCANO	97	EAPT	447	FDSC60LR	431
BPTE30	182	CMPWU-PPCONO	97	EASR24	446	FDSC60R	431
BPTE48	192	CSC-MUCONO	95	EASR30	446	FDSC60U	431
BPTE60	182	CSC-MUGONO	95	EASR36	446	FDSC66LL	431
BPTS24	192	CSC-UUCONO	95	EASR42	446	FDSC66LR	431
BPTS30	182	CSC-UUGONO	95	EASR48	446	FDSC66R	431
BPTT	196	CSDC19	448	EASR60	446	FDSC66U	431
BPWB	190	CSDC25	448	EASS	447	FDSC72LL	431
BPWBL	190	CSG-PGANO	144	EATS	447	FDSC72LR	431
BPWBR	190	CSG-PGANOSP	144	EB39M	284	FDSC72R	431
BPWCM	188	CSL-PGANO	144	EB39S	284	FDSC72U	431
BPWCPL	194	CSL-PGANOSP	144	EB2142M	284	FDSC148LK	431
BPWCRPL	194	CSS-MHA	90	EB2142S	284	FDSC148RK	431
BPWCS	186	CSS-MHF	90	EB4242M	284	FDSC154LK	431
BPWEL	194	CSS-MHH	90	EB4242S	284	FDSC154RK	431
BPWELC	194	CSS-MHW	90	EPB1421HM	282	FDSC160LK	431
BPWLM	188	CSS-MMA	90	EPB1421HS	280	FDSC160RK	431
BPWLS	186	CSS-MMF	90	EPB1421M	282	FDSC166LK	431
BPWO	190	CSS-MMH	90	EPB1421S	280	FDSC166RK	431
BPWRM	188	CSS-MMW	90	EPB1442M	282	FDSC172LK	431
BPWRS	186	CSW-MHA	88	EPB2121HM	282	FDSC172RK	431
BPWSIC	194	CSW-MHF	88	EPB2121HS	280	FDSCR48K	431
BPWSIL	194	CSW-MHH	88	EPB2121M	282	FDSCR54K	431
BPWSIL15	194	CSW-MHW	88	EPB2121S	280	FDSCR60K	431
BPWSIL30	194	CSW-MMA	88	EPB2128M	282	FDSCR66K	431
BPWSM	188	CSW-MMF	88	EPB2128S	280	FDSCR72K	431
BPWSNM	188	CSW-MMH	88	EPB2142M	282	FDSCU48K	431
BPWSNS	186	CSW-MMW	88	EPB2142S	280	FDSCU54K	431
BPWSO	190	CUBS-PGANO	144	EPP1722HM	282	FDSCU60K	431
BPWSPL	194	CUBS-PGANOSP	144	EPP1722HS	280	FDSCU66K	431
BPWSS	186	CUCS-PGANO	144	EPP1722M	282	FDSCU72K	431
BPWSWM	188	CUCS-PGANOSP	144	EPP1722S	280	FWS-MHANO	114
BPWSWS	186	CWS-PPGA	100	EPP1820HM	282	FWS-MHFNO	114
BPWTL	190	CWS-PPGO	100	EPP1820HS	280	FWS-MHHNO	114
BPWTR	190	CWSS30-PPGA	100	EPP1820M	282	FWW-MHANO	114

Cross Reference Index

by Model Number

Model	Page	Model	Page	Model	Page	Model	Page
FWW-MHFNO	114	INST-UCA	74	MLM22	242, 350	PRFTSKTR	452
FWW-MHHNO	114	INST-UCO	74	MLM26	242, 350	PSASC	272
GA56HSE	314	INST-UGA	74	MLM27	240	PSASN	272
GA56MSE	312	INST-UGO	74	MLM27S	240	PSBC	272
GA70HCOLHP	314	INTK-NA	80	MLM35	238	PSBN	272
GA70HCOLNP	314	INTK-NO	80	MLM35S	238	PSCC	272
GA70HCOUHP	314	INTK-SA	80	MLM36	234	PSCN	272
GA70HCOUNP	314	INTK-SO	80	MLM36S	234	PSCPC	272
GA70HMCL	314	INTK-UA	80	MLM37	234	PSCP	272
GA70HMCU	314	INTK-UO	80	MLM37S	234	PSDSC	272
GA70HSTHL	314	INWS-NA	82	MLM38	240	PSDSN	272
GA70HSTHR	314	INWS-NO	82	MLM38S	240	PSLCC	274
GA70HSTNP	314	INWS-SA	82	MLM39	240	PSLCN	274
GA70MCOLHP	312	INWS-SO	82	MLM39S	240	PSLSC	274
GA70MCOLNP	312	INWS-UA	82	MLM40	240	PSLSN	274
GA70MCOUHP	312	INWS-UO	82	MLM40S	240	PSRCC	274
GA70MCOUNP	312	K-MPCA	136	MLM41	240	PSRCN	274
GA70MMCL	312	K-MPCO	136	MLM41S	240	PSRSC	274
GA70MMCU	312	K-MPGA	136	MLM42	240	PSRSN	274
GA70MSTHL	312	K-MPGO	136	MLM42J	243, 251.1	PTCTL	276, 329
GA70MSTHR	312	K-MUCA	136	MLM42S	240	PTCTS	276, 329
GA70MSTNP	312	K-MUCO	136	MLM43	240	PTCTV	276, 329
GA84HMW	314	K-MUGA	136	MLM43S	240	PTLTL	276, 329
GA84HSE	314	K-MUGO	136	MLM44	238	PTLTS	276, 329
GA84HSTHL	314	K-PPCA	136	MLM44S	238	PTLTV	276, 329
GA84HSTHR	314	K-PPCO	136	MLM72J	243, 251.1	PTSTL	276, 329
GA84HSTNP	314	K-PPGA	136	MLMGK	243	PTSTS	276, 329
GA84MMW	312	K-PPGO	136	MLML15	242	PTSTV	276, 329
GA84MSE	312	K-PUCA	136	MLMR15	242	RETECLM	266
GA84MSTHL	312	K-PUCO	136	MLUK	104	RETECLS	266
GA84MSTHR	312	K-PUGA	136	MNL-LUK	110	RETECM	266
GA84MSTNP	312	K-PUGO	136	MNL-MHA	110	RETECMS	266
GAPWRMW	317	LLUK	88	MNL-MHH	110	RETWLM	266
GAPWRMWCH	317	LLUK-LT	93	MNL-MHW	110	RETWLS	266
GAPWRMWNY	317	LSTNO	117	MNLS-MHA	110	RETWMM	266
GATBLEXT	317	MIS-KANO	104	MNLS-MHH	110	RETWMS	266
GATVMB	317, 386, 540	MIS-KWNO	104	MNLS-MHW	110	RFDRW48	434
GAWRP	303	MIW-KANO	104	NA4815RB	223, 336	RFDRW54	434
GS870924	451	MIW-KWNO	104	NA4828RB	223, 336	RFDRW60	434
GS870930	451	MLM1	234	NAE1	226, 338, 346, 354	RFDRW66	434
GS870948	451	MLM1S	234	NAE2	226, 338, 346, 354	RFDRW72	434
GS870960	451	MLM2	234	NAE3-IUSB	226, 354	RFDRWAB	434
INFS-NGA	84	MLM2S	234	NAE3-3USB	226, 354	RFDRWCNPP	436
INFS-NGO	84	MLM3	236	NAE4	226, 354	RFDRWCNPPPE	436
INFS-SGA	84	MLM3S	236	NAEESL	226, 346, 354	RFDRWCNPPM	436
INFS-SGO	84	MLM4	236	NAHD	218	RFDRWHUBEND	435
INFS-UGA	84	MLM4S	236	NAHDM	220	RFDRWHUBENDT	435
INFS-UGO	84	MLM5	238	NAHDMW	220	RFDRWHUBL	435
INSL-NA	76	MLM5S	238	NAHDW	218	RFDRWHUBLIN	435
INSL-NO	76	MLM6	238	NAHP	225, 337	RFDRWHUBT	435
INSL-SA	76	MLM6S	238	NAHS	218	RFDRWHUBX	435
INSL-SO	76	MLM7	238	NAHSM	220	RFDRWLEG	434
INSL-UA	76	MLM7S	238	NAHSMW	220	RFDRWSC48	437
INSL-UO	76	MLM8	238	NAHSW	218	RFDRWSC54	437
INST-NCA	74	MLM8S	238	NALC	224, 336	RFDRWSC60	437
INST-NCO	74	MLM9	236	NALCF	224, 353	RFDRWSC66	437
INST-NGA	74	MLM9S	236	NALD	218	RFDRWSC72	437
INST-NGO	74	MLM10	236	NALDM	220	RFDRWWM	436
INST-SCA	74	MLM10S	236	NALDMW	220	RLA-MHA	122
INST-SCO	74	MLM11	236	NALDW	218	RLA-MHP	122
INST-SGA	74	MLM11S	236	NALP	225, 337	RLA-UHA	122
INST-SGO	74	MLM13	236	NALS	218	RLA-UHP	122
INSTT-NCAFLS	78	MLM13S	236	NALSM	220	RLC-MUGA	133
INSTT-NCAFRS	78	MLM15N	242	NALSMW	220	RLC-MUGO	133
INSTT-NGAFLS	78	MLM16	242	NALSW	218	RLC-UUGA	133
INSTT-NGAFRS	78	MLM16N	242	NAPT	225, 337	RLC-UUGO	133
INSTT-SCAFLS	78	MLM17	242	NAPWT	224, 345	RLC-WUGA	133
INSTT-SCAFRS	78	MLM17N	242	NARC	222, 336	RL-MHA	120
INSTT-SGAFLS	78	MLM18	242, 341	NMBL-1FC	107	RL-MHP	120
INSTT-SGAFRS	78	MLM19	242, 350	NMBL-2FC	107	RLM-MUCA	130
INSTT-UCAFLS	78	MLM20	234	NMBL-CART	107	RLM-MUCO	130
INSTT-UCAFRS	78	MLM20S	234	NMBL-GANG	107	RLM-MUGA	130
INSTT-UGAFLS	78	MLM21	234	PRFTSKCL	452	RLM-MUGO	130
INSTT-UGAFRS	78	MLM21S	234	PRFTSKFS	452	RLM-UUCA	130

Cross Reference Index

by Model Number

Model	Page	Model	Page	Model	Page	Model	Page
RLM-UUCO	130	S913WPB4242	498	S942LTSE3696	501	S942PTSE48120	501
RLM-UUGA	130	S913WPB4829	498	S942LTSE3696NP	502	S942PTSE48120NP	502
RLM-UUGO	130	S913WPB4842	498	S942LTSE4272	501	S942PTST545QR	501
RLM-WUGA	130	S913WTF3620	497	S942LTSE4272NP	502	S942PTST545QRNP	502
RLS-MHA	126	S913WTF3672	497	S942LTSE4284	501	S942PTST605QR	501
RLS-MHP	126	S913WTF3696	497	S942LTSE4284NP	502	S942PTST605QRNP	502
RL-UHA	120	S913WTF4220	497	S942LTSE4296	501	S942PTST3672	501
RL-UHP	120	S913WTF4272	497	S942LTSE4296NP	502	S942PTST3672NP	502
S911NH	330	S913WTF4296	497	S942LTSE4872	501	S942PTST3684	501
S911NL	330	S913WTF4820	497	S942LTSE4872NP	502	S942PTST3684NP	502
S911NM	330	S913WTF4872	497	S942LTSE4884	501	S942PTST3696	501
S911RLTB	342	S913WTF4896	497	S942LTSE4884NP	502	S942PTST3696NP	502
S912B1632	328	S913WTS3620	497	S942LTSE4896	501	S942PTST4272	501
S912B2116	328	S913WTS3672	497	S942LTSE4896NP	502	S942PTST4272NP	502
S912T16G	328	S913WTS3696	497	S942LTSE36120	501	S942PTST4284	501
S912T16L	328	S913WTS4220	497	S942LTSE36120NP	502	S942PTST4284NP	502
S912T16V	328	S913WTS4272	497	S942LTSE42120	501	S942PTST4296	501
S912T32G	328	S913WTS4296	497	S942LTSE42120NP	502	S942PTST4296NP	502
S912T32L	328	S913WTS4820	497	S942LTSE48120	501	S942PTST4872	501
S912T32V	328	S913WTS4872	497	S942LTSE48120NP	502	S942PTST4872NP	502
S913LNB3629	498	S913WTS4896	497	S942LTST545QR	501	S942PTST4884	501
S913LNB3642	498	S922GB	258	S942LTST545QRNP	502	S942PTST4884NP	502
S913LNB4229	498	S922LPN	254	S942LTST605QR	501	S942PTST4896	501
S913LNB4242	498	S922P4NYK	243, 251.1	S942LTST605QRNP	502	S942PTST4896NP	502
S913LNB4829	498	S922P4S72K	243, 251.1	S942LTST3672	501	S942PTST36120	501
S913LNB4842	498	S922P4S144K	251.1	S942LTST3672NP	502	S942PTST36120NP	502
S913LPB3629	498	S922S2	250	S942LTST3684	501	S942PTST42120	501
S913LPB3642	498	S922S2IC	250	S942LTST3684NP	502	S942PTST42120NP	502
S913LPB4229	498	S922S2LN	252	S942LTST3696	501	S942PTST48120	501
S913LPB4242	498	S922S2LP	252	S942LTST3696NP	502	S942PTST48120NP	502
S913LPB4829	498	S922S2LTN	256	S942LTST4272	501	S943LTSE545QR	504
S913LPB4842	498	S922S2LTP	256	S942LTST4272NP	502	S943LTSE545QRNP	505
S913LTF3620	497	S922S2OC	250	S942LTST4284	501	S943LTSE605QR	504
S913LTF3672	497	S922S2P	250	S942LTST4284NP	502	S943LTSE605QRNP	505
S913LTF3696	497	S922S2T	250	S942LTST4296	501	S943LTSE3672	504
S913LTF4220	497	S922S2TIC	250	S942LTST4296NP	502	S943LTSE3672NP	505
S913LTF4272	497	S922S2TOC	250	S942LTST4872	501	S943LTSE3684	504
S913LTF4296	497	S922S2TP	250	S942LTST4872NP	502	S943LTSE3684NP	505
S913LTF4820	497	S922S3	250	S942LTST4884	501	S943LTSE3696	504
S913LTF4872	497	S922S3P	250	S942LTST4884NP	502	S943LTSE3696NP	505
S913LTF4896	497	S922S3T	250	S942LTST4896	501	S943LTSE4272	504
S913LTS3620	497	S922S3TP	250	S942LTST4896NP	502	S943LTSE4272NP	505
S913LTS3672	497	S922SAN	254	S942LTST36120	501	S943LTSE4284	504
S913LTS3696	497	S922SATN	256	S942LTST36120NP	502	S943LTSE4284NP	505
S913LTS4220	497	S922SATWN	256	S942LTST42120	501	S943LTSE4296	504
S913LTS4272	497	S922SAWN	254	S942LTST42120NP	502	S943LTSE4296NP	505
S913LTS4296	497	S922SHON	252	S942LTST48120	501	S943LTSE4872	504
S913LTS4820	497	S922SHOTN	256	S942LTST48120NP	502	S943LTSE4872NP	505
S913LTS4872	497	S922SHOTWN	256	S942PTSE545QR	501	S943LTSE4884	504
S913LTS4896	497	S922SHOWN	252	S942PTSE545QRNP	502	S943LTSE4884NP	505
S913P05LJ	499	S922SON	252	S942PTSE605QR	501	S943LTSE4896	504
S913P06CE	499	S922SOP	252	S942PTSE605QRNP	502	S943LTSE4896NP	505
S913P06CM	499	S922SOTN	256	S942PTSE3672	501	S943LTSE36120	504
S913P06LS	499	S922SOTP	256	S942PTSE3672NP	502	S943LTSE36120NP	505
S913P10LS	499	S922SOTWN	256	S942PTSE3684	501	S943LTSE42120	504
S913P12CE	499	S922SOTWP	256	S942PTSE3684NP	502	S943LTSE42120NP	505
S913P12CM	499	S922SOWN	252	S942PTSE3696	501	S943LTSE48120	504
S913P20CE	499	S922SOWP	252	S942PTSE3696NP	502	S943LTSE48120NP	505
S913P20CM	499	S922SWDN	252	S942PTSE4272	501	S943LTST545QR	504
S913P20HE	499	S922SWDP	252	S942PTSE4272NP	502	S943LTST545QRNP	505
S913P20HM	499	S922SWDWN	252	S942PTSE4284	501	S943LTST605QR	504
S913PLE	499	S922SWDWP	252	S942PTSE4284NP	502	S943LTST605QRNP	505
S913PLHE	499	S922SWN	254	S942PTSE4296	501	S943LTST3672	504
S913PLHED	499	S922SWTN	256	S942PTSE4296NP	502	S943LTST3672NP	505
S913PLM	499	S924SS	299	S942PTSE4872	501	S943LTST3684	504
S913WNB3629	498	S924ST	299	S942PTSE4872NP	502	S943LTST3684NP	505
S913WNB3642	498	S942LTSE545QR	501	S942PTSE4884	501	S943LTST3696	504
S913WNB4229	498	S942LTSE545QRNP	502	S942PTSE4884NP	502	S943LTST3696NP	505
S913WNB4242	498	S942LTSE605QR	501	S942PTSE4896	501	S943LTST4272	504
S913WNB4829	498	S942LTSE605QRNP	502	S942PTSE4896NP	502	S943LTST4272NP	505
S913WNB4842	498	S942LTSE3672	501	S942PTSE36120	501	S943LTST4284	504
S913WPB3629	498	S942LTSE3672NP	502	S942PTSE36120NP	502	S943LTST4284NP	505
S913WPB3642	498	S942LTSE3684	501	S942PTSE42120	501	S943LTST4296	504
S913WPB4229	498	S942LTSE3684NP	502	S942PTSE42120NP	502	S943LTST4296NP	505

Cross Reference Index

by Model Number

Model	Page	Model	Page
S943LTST4872	504	U9TM	438
S943LTST4872NP	505	U9TP	438
S943LTST4884	504	U9TS	438
S943LTST4884NP	505	U9WTC	438
S943LTST4896	504	U912WTR	438
S943LTST4896NP	505	U918WTR	438
S943LTST36120	504	U924WTR	438
S943LTST36120NP	505	U930WTR	438
S943LTST42120	504	U936WTR	438
S943LTST42120NP	505	U942WTR	438
S943LTST48120	504	U948WTR	438
S943LTST48120NP	505	U954WTR	438
S943VTSE545QR	504	U960WTR	438
S943VTSE545QRNP	505	U966WTR	438
S943VTSE605QR	504	UN2HPSQ	436
S943VTSE605QRNP	505	UN2HPSQSK	436
S943VTSE3672	504	VATWMG	50
S943VTSE3672NP	505	VERHNO	264
S943VTSE3684	504	VERLNO	264
S943VTSE3684NP	505	VERONO	264
S943VTSE3696	504	VERWNO	264
S943VTSE3696NP	505	WANDFS	452
S943VTSE4272	504	WANDFSOC	452
S943VTSE4272NP	505	WANDFSUSB	452
S943VTSE4284	504	WKSWMC	427, 453.2, 551.1
S943VTSE4284NP	505	Z5SC42	394
S943VTSE4296	504	Z5SC48	394
S943VTSE4296NP	505	Z5SC54	394
S943VTSE4872	504	Z5SC60	394
S943VTSE4872NP	505	Z5SC66	394
S943VTSE4884	504	Z5SC72	394
S943VTSE4884NP	505	Z5SC78	394
S943VTSE4896	504	Z5SC84	394
S943VTSE4896NP	505		
S943VTSE36120	504		
S943VTSE36120NP	505		
S943VTSE42120	504		
S943VTSE42120NP	505		
S943VTSE48120	504		
S943VTSE48120NP	505		
S943VTST545QR	504		
S943VTST545QRNP	505		
S943VTST605QR	504		
S943VTST605QRNP	505		
S943VTST3672	504		
S943VTST3672NP	505		
S943VTST3684	504		
S943VTST3684NP	505		
S943VTST3696	504		
S943VTST3696NP	505		
S943VTST4272	504		
S943VTST4272NP	505		
S943VTST4284	504		
S943VTST4284NP	505		
S943VTST4296	504		
S943VTST4296NP	505		
S943VTST4872	504		
S943VTST4872NP	505		
S943VTST4884	504		
S943VTST4884NP	505		
S943VTST4896	504		
S943VTST4896NP	505		
S943VTST36120	504		
S943VTST36120NP	505		
S943VTST42120	504		
S943VTST42120NP	505		
S943VTST48120	504		
S943VTST48120NP	505		
SV2HCNO	140		
SV2HPNO	140		
SV2MCNO	140		
SV2MPNO	140		
U7WDA	448, 484		
U9TF	438		

INDEX



Allsteel®

Allsteel Inc.
Muscatine, Iowa 52761

allsteeloffice.com

Form #A8748.A5 (05/24)