

CAM LOCK ASSEMBLY

INSTALLATION INSTRUCTIONS

Illustration 1

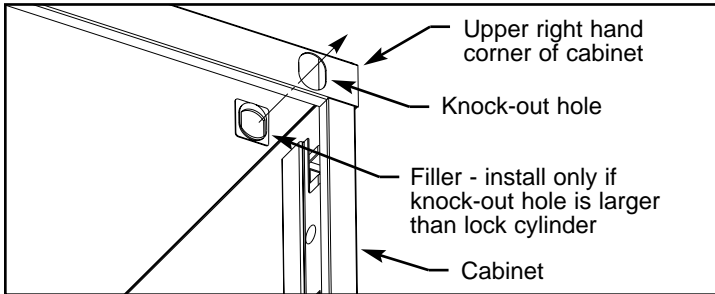

Illustration 2

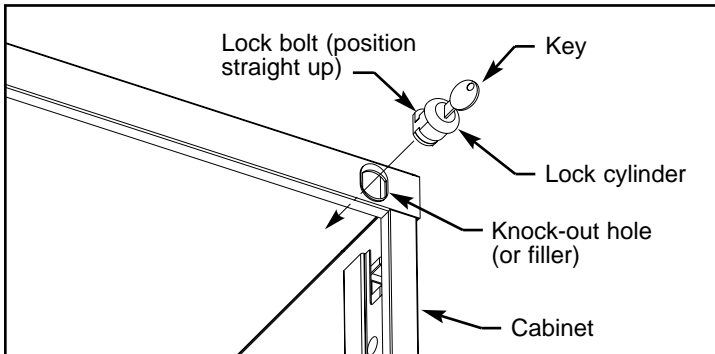

Illustration 3

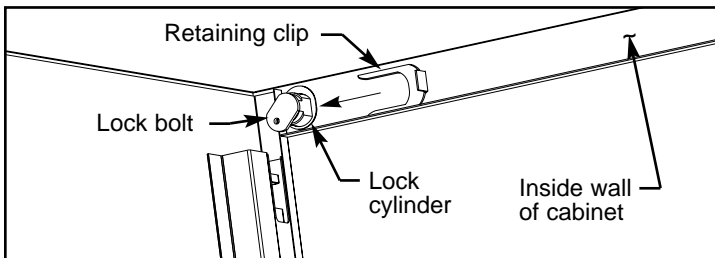
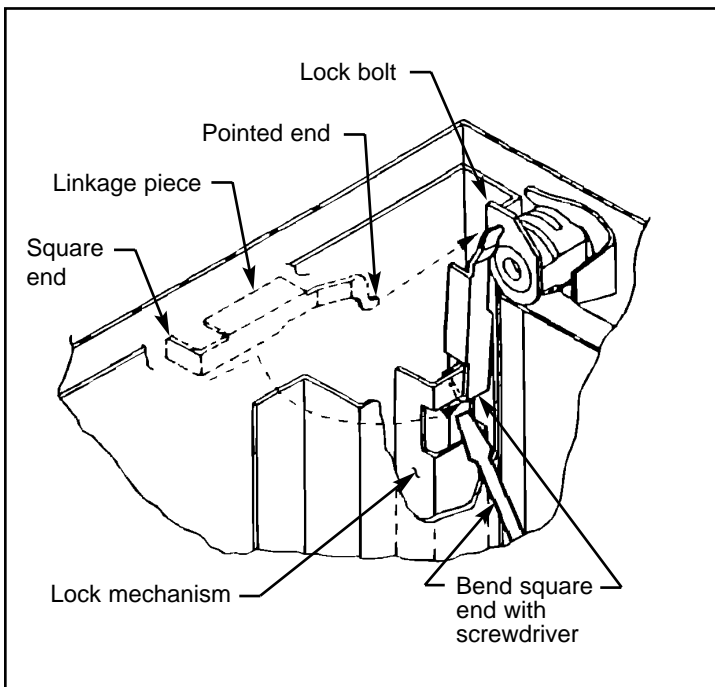

Illustration 4



Read all instructions and review illustrations before installing.

Tools required for assembly: Straight blade screwdriver Flashlight	Punch Hammer
--	-----------------

This assembly includes: (1) Lock cylinder (1) Retaining clip	(1) Filler (1) Linkage piece
--	---------------------------------

WARNING
Removing a loaded drawer can cause the cabinet to tip and fall. To avoid injury, empty contents of drawer before removing from cabinet. Sharp edges may cause injury. Take care when handling metal parts.

- Installation:**
1. Remove contents from top drawer.
 2. Remove top drawer from cabinet by opening completely, lifting front approximately 2 1/2", and sliding out until free of cradle assembly.
 3. Refer to Illustration 1. Locate knockout at upper right corner of cabinet. On the outside of the cabinet, place punch at the center of knockout and tap end of punch with the hammer.

NOTE
The installation of the filler is only required when the size of the knock-out hole is larger than the lock cylinder. If installation of the filler is not required, go to step 5.

4. Refer to Illustration 1. From inside of cabinet, install filler into knock-out hole as shown.
5. Refer to Illustration 2. Rotate key in lock cylinder so bolt is positioned upward. Insert lock cylinder (with key in it) into hole in cabinet. Lock bolt should be straight up when inserted.

NOTE
Ensure lock bolt is positioned straight up when inserting lock cylinder into knock-out hole (or filler) or lock cylinder will be difficult to install.

6. Rotate key clockwise 1/4 turn.
7. Refer to Illustration 3. Place retaining clip flush against inside wall of cabinet. While holding lock cylinder in place with one hand, slide retaining clip over lock cylinder. Retaining clip prongs should fit into grooves on top and bottom of lock cylinder.
8. Refer to Illustration 4. Insert pointed end of linkage piece into predrilled hole in lock bolt (use the flashlight if needed). Pivot linkage piece downward and insert square end into lock mechanism.
9. Refer to Illustration 4. Use the screwdriver to bend square end of linkage piece up to secure. Turn key a few times to check operation.
10. Reinstall drawer by lowering rear of drawer into cradle assembly and sliding drawer closed. Carefully slide drawer open to verify drawer slides freely and drawer stop operates properly.
11. Reload drawer.