

Dual Fabric Application Cityscape 2.0 Modulares

EVERY UNIT SHIPPED INCLUDES LEG KIT
GANGING BRACKETS SOLD SEPARATELY

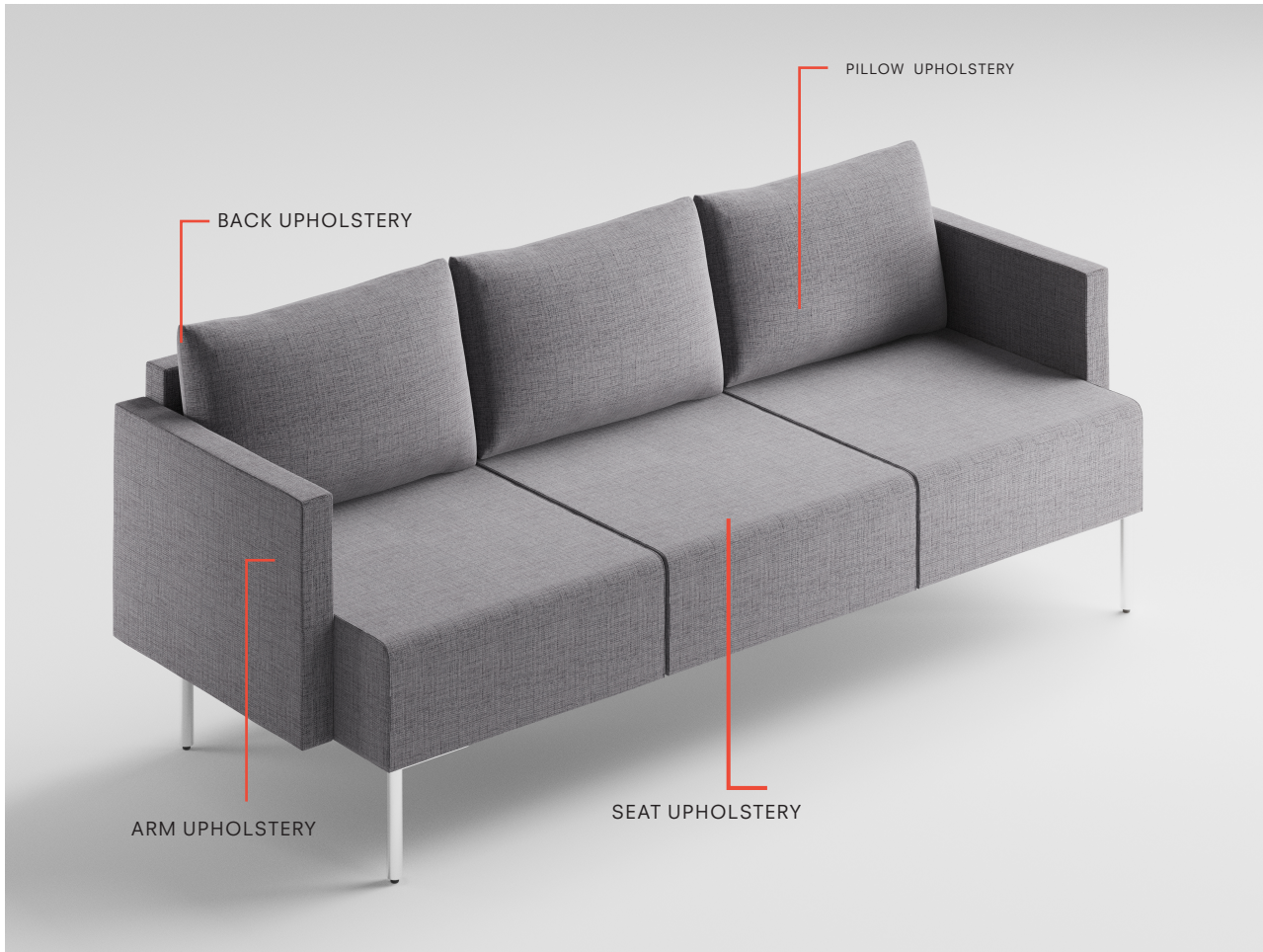

DATE _____

PURCHASE ORDER NO. _____

LINE NO. _____

BACK _____

SEAT _____

ARMS _____

PILLOW _____

COMPANY NAME _____

EMAIL ADDRESS _____

SIGNATURE _____



Dual Fabric Application Cityscape 2.0 Modulares

Freestanding Modules

CITYSCAPE 2.0 FREESTANDING MODULE SEATING WITH ARMS

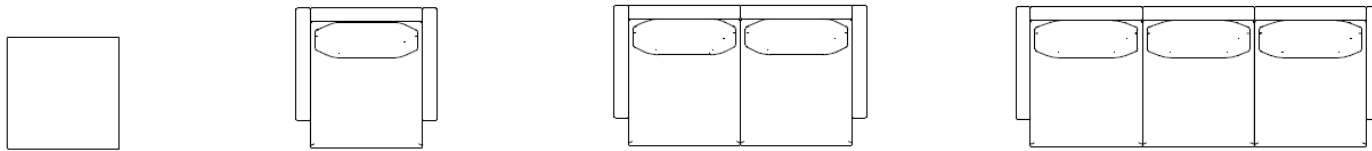
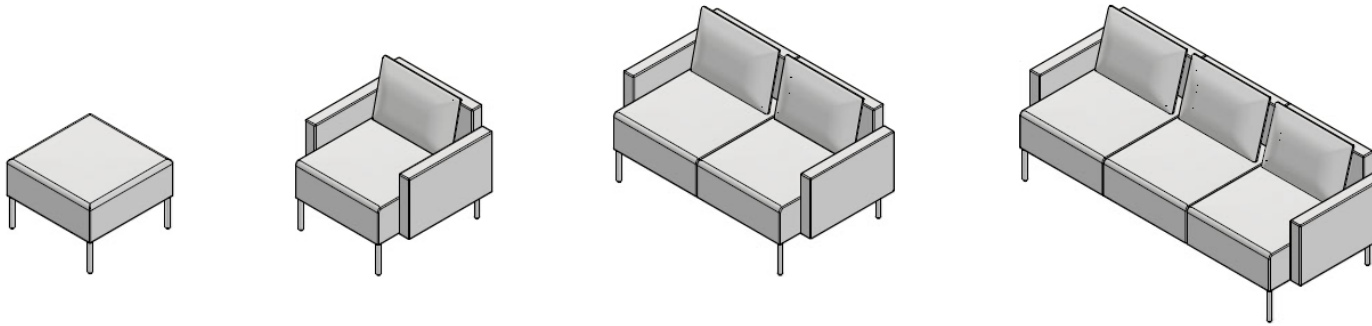

HLD421-044

HLD421-041

HLD421-042

HLD421-043

CITYSCAPE 2.0 FREESTANDING ARMLESS MODULE SEATING

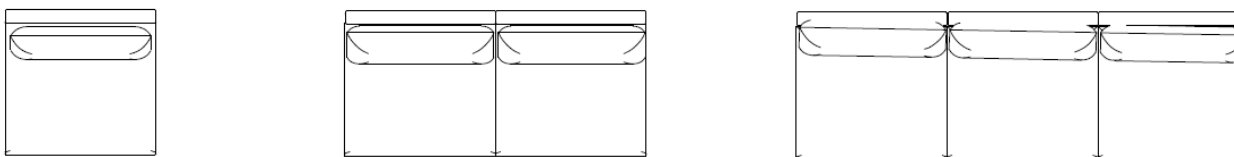
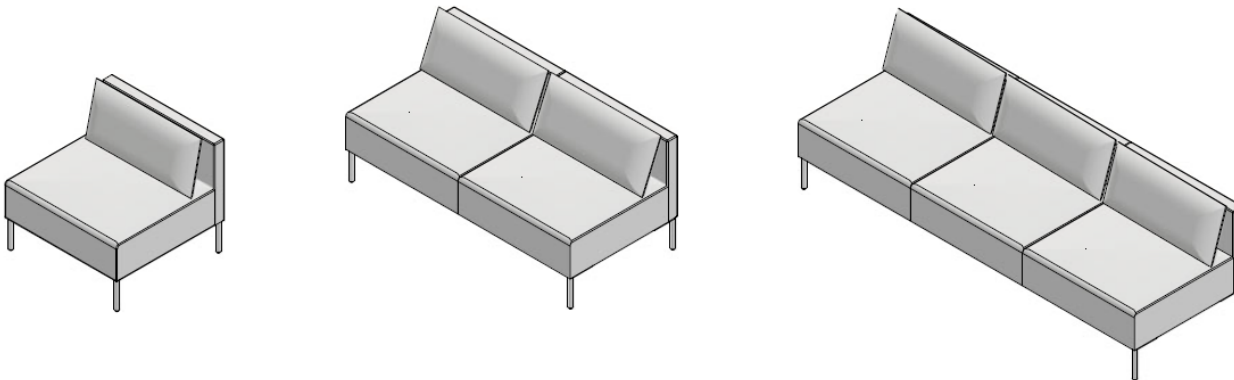

HLD421-021

HLD421-022

HLD421-023



Dual Fabric Application Cityscape 2.0 Modulares

Freestanding Pentagons
Modular Dual-Sided
Seating without Backs

CITYSCAPE 2.0 FREESTANDING PENTAGON UNITS

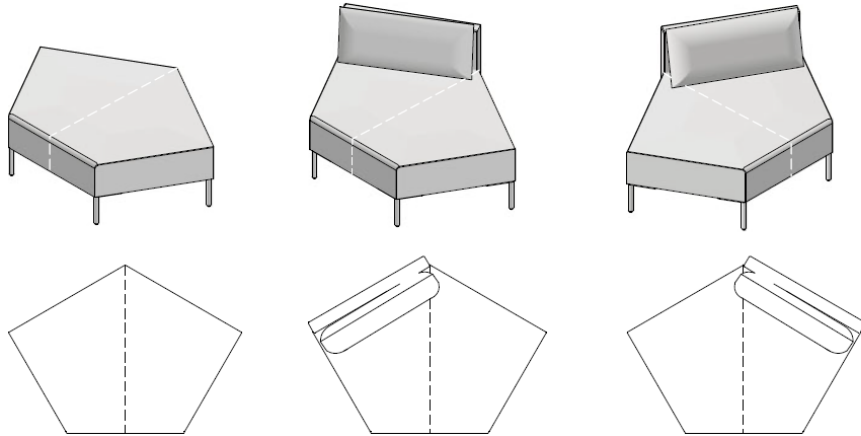

HLD421-014

HLD421-024

HLD421-034

CITYSCAPE 2.0 MODULAR DUAL-SIDED ADD-ON SEATING UNITS WITHOUT BACKS*

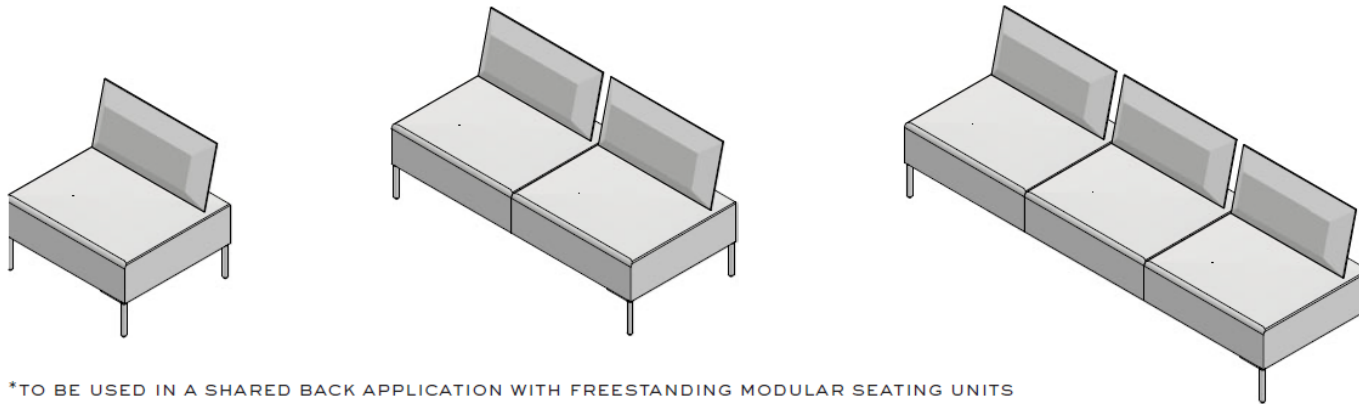

*TO BE USED IN A SHARED BACK APPLICATION WITH FREESTANDING MODULAR SEATING UNITS

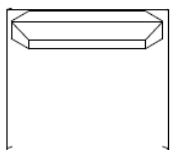

HLD421-011

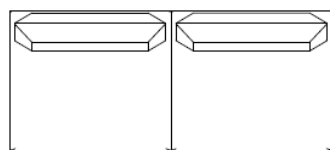

HLD421-012

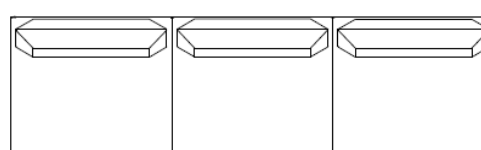

HLD421-013

EVERY UNIT SHIPPED INCLUDES LEG KIT



Dual Fabric Application Cityscape 2.0 Modulares

Typical Configurations

EVERY UNIT SHIPPED INCLUDES LEG KIT

