

Finding harmony in the details.

HBF reveals the intentionality of design in everything we make through attention to detail and bespoke American craftsmanship.

Technical precision is married to honesty of materials and purity of form, making the use of your chair a simple process. Please follow these basic instructions for tilt/tension, seat height, and locking adjustments.

Cadre Knee Tilt



HICKORY, NC
828 328 2064 WWW.HBF.COM

HBF

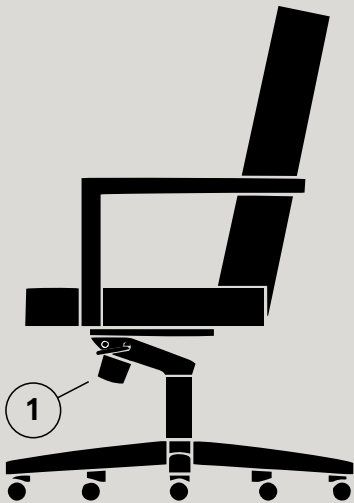

1—Tilt Tension

To adjust the tension to the backward tilt, grasp the textured hand wheel located underneath the front of the chair. A clockwise rotation while seated will loosen the tension, counterclockwise rotation will tighten the tension.

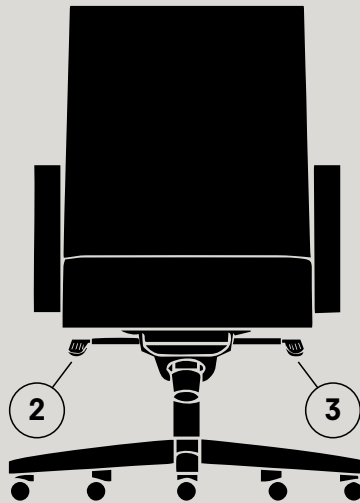

2—Height

While seated, lift the right hand lever. Your weight on the seat will lower the height. By leaning forward and transferring your weight to your feet you will raise the seat height by again lifting the lever.

3—Lock

To set your chair in a fixed upright position (5°), grasp the short lever at the front of the chair control. While pushing back gently on the chair back turn the knob towards the rear of the chair and then push down on the left hand lever. To set your chair in a fixed forward tilt position (0°), turn the short right front lever to the forward position and then push down on the left hand lever. To deactivate the locking mechanism pull up on the left hand lever.