

CITYSCAPE 2.0
LIST PRICES EFFECTIVE
FEBRUARY 1, 2024

CITYSCAPE 2.0 

STATE OF NORTH CAROLINA

2 0 2 4



Mailing Address:

HBF
PO Box 8
Hickory NC 28603-0008

Shipping Address:

HBF
900 - 12th Street Drive NW
Hickory NC 28601-4763

Contact:

Phone: 1.855.HBF.2020
828.328.2064
Fax: 828.485.2690
Info: hbfservice@hbf.com
www.hbf.com

Order Processing:

Phone: 1.855.HBF.2020
828.328.2064
Fax: 828.485.2690
hbforders@hbf.com

GENERAL INFORMATION	PAGE
ANSI/BIFMA e3-2014e Furniture Sustainability.....	5
COM Ordering Requirements.....	3
Combinations of Upholstery Applications	4
Dimension Guide	5
GSA	6
HBF Textiles Graded Product	8
High Performance Products	6
Product Material Options	7
Indoor Advantage™ Gold Certified	5
Seating Ordering Procedure	2
Special Code Compliance – CAL 117.....	4
Specifications - Lounge	9
Specifications - Tables.....	30
Spring Down Cushions.....	6
Statement of Line.....	10
Tables - Dimension Guide.....	15
Typical Configurations	12
Yardage Requirements.....	2

	PAGE
Cityscape 2.0 - Freestanding Modular Seating	
One Seat Modular Lounge Seating - Armless with Back	16
Two Seat Modular Lounge Seating - Armless with Back.....	17
Three Seat Modular Lounge Seating - Armless with Back.....	18
Cityscape 2.0 - Dual-Sided Add-On Modular Seating Units	
One Seat Lounge Seating - No Arms, No Back	19
Two Seat Lounge Seating - No Arms, No Back.....	20
Three Seat Lounge Seating - No Arms, No Back.....	21
Pentagon Chaise Lounge Seating - LSF Back.....	22
Pentagon Chaise Lounge Seating - RSF Back.....	23
Cityscape 2.0 - Armchairs & Sofas	
Armchair	24
Two-Seater.....	25
Three-Seater.....	26
Cityscape 2.0 - Ottomans	
Pentagon Ottoman Backless.....	27
Square Ottoman	28
Cityscape 2.0 - Modular Connecting Tables	
Rectangular with Rectangular Top Table.....	31, 33
Rectangular with Round Top Table.....	32, 34, 35
Ganging Leg Kit	29
Power.....	30, 36



Coverings

All upholstered items may be ordered using HBF Textiles, HBF Leathers, or coverings provided by the customer. Prices listed as COM refer to Customer's Own Material, which includes textiles and leather. Prices listed as GRADE refer to HBF Textiles and/or HBF Leather.

Yardage requirements shown in the price list are based on non-directional 54" wide material. The following conversion chart should be used to determine yardage requirements when COM textile is 54" wide or less and/or has a repeat of 2" or more. Add together the vertical and horizontal repeat to determine which column should be used as a reference.

Fabric Width	Plain Fabric	2"-10" Repeat	11"-20" Repeat	21"-25" Repeat	26"-30" Repeat	31"-35" Repeat	36"-40" Repeat	41"-45" Repeat
54"	+ 0%	+10%	+15%	+20%	+25%	+30%	+35%	+40%
51"-53"	15%	20%	25%	30%	35%	40%	45%	50%
48"-50"	30%	35%	40%	45%	50%	55%	60%	65%
45"-47"	45%	50%	55%	60%	65%	70%	75%	80%
36"-44"	60%	65%	70%	75%	80%	85%	90%	95%

To determine the possibility of reduced yardage requirements for orders of thirty (30) or more units, please contact The HBF Client Experience Team. HBF reserves the right to request additional yardage of COM at customer expense based on repeat and/or pattern size, and number of rolls.

All COM's must be approved for application before the purchase order is submitted to HBF. Please contact The HBF Client Experience Team at hbfservice@hbf.com to verify that your COM fabric has been approved. If it has not, please request COM approval testing via www.hbf.com under COM Request. Failure to submit a COM for testing may result in additional expenses or rejection of COM. For any repeat and/or pattern size not listed, please contact The HBF Client Experience Team for a yardage requirement quotation.

HBF cannot be held responsible for performance, color accuracy, or weaving of COM materials. All responsibility for COM shipments is between the purchaser and the textile/leather source. HBF reserves the right to reject any COM. HBF assumes no responsibility for suitability or wearability of COM. Difficult COM may be subject to additional charge if additional labor costs are incurred. HBF assumes no responsibility for the flame retardance of any COM. Customers are solely responsible for making sure that COM complies with all applicable codes and regulations. Orders specifying COM will not be scheduled for production until all approved COM(s) are received by HBF. To ensure proper COM expediting, please tag fabric/leather roll(s) with the following information: 1. Purchasing dealer name and purchase order number 2. HBF acknowledgment number, if available 3. Other pertinent information which will enable proper COM identification.

When sending COM leather for use on one of our upholstered pieces, please send eighteen (18) square feet of leather for each yard of 54" plain fabric required for that item.



Coverings (Continued)

COM ORDERING REQUIREMENTS:

Prior to acceptance of order specifying COM, a memo sample must be submitted to HBF for determination of suitability. All COM's must be rolled separately, on individual tubes. Multiple materials rolled on the same tube will not be accepted.

For ease of expediting your COM order, we require the following information:

- | | |
|---|------------------------------|
| 1. Material description | Shipping Address: HBF |
| 2. Material source | 900 12th Street Drive NW |
| 3. Order line, product name or number | Hickory, NC 28601-4763 |
| 4. Material color | |
| 5. A swatch of the covering | |
| 6. Special application instructions, if any | |

If COM is of a type requiring choices of seam placement, face side, position of design or repeat; these instructions must be clearly stated on the original order.

HBF cannot be held responsible for performance, color accuracy, or weaving of COM materials. All responsibility for COM shipments is between the purchaser and the textile/leather source.

HBF reserves the right to reject any COM. HBF assumes no responsibility for suitability or wearability of COM. Difficult COM may be subject to additional charge if additional labor costs are incurred.

HBF assumes no responsibility for the flame retardance of any COM. Customers are solely responsible for making sure that COM complies with all applicable codes and regulations.

Orders specifying COM will not be scheduled for production until all approved COM is received by HBF.

To ensure proper COM expediting, please tag textile/leather with the following information:

1. Purchasing dealer name and purchase order number
2. HBF acknowledgement number, if available
3. Other pertinent information which will enable proper COM identification



Combination of Upholstery Applications

All seating ordered with combination upholstery application (fabric, leather) that **is not** offered as standard is subject to a **\$103 List Upholstery upcharge** and will be entered and processed as a special model, in addition to the following pricing conditions:

1. Combinations using HBF Textiles and COM will be priced at the COM price. The cost of the portion of the HBF Textiles used, will be entered as a miscellaneous charge on the furniture order.
2. Combinations using HBF Textiles and HBF Leathers, or COM and HBF Leathers, will be priced at the appropriate Leather I-V price.
3. Combinations using two HBF Textiles will be invoiced at higher grade price.
4. When specifying combination of upholstery applications, a sketch indicating placement of textiles and direction of applications must accompany the purchase order.

Special Code Compliance

California #117-2013

Unless otherwise specified, foam used in all HBF seating products complies with these guidelines.

Boston Fire Code

New York Port Authority

Please contact the HBF Client Experience Team if compliance is required for these special codes.



**ANSI/BIFMA e3-2014e
LEVEL® Furniture
Sustainability Standard
Certification**

A majority of HBF’s products have met the necessary qualifications to achieve LEVEL® certification. LEVEL® is the multi-attribute sustainability certification based on the ANSI/BIFMA e3 Furniture Sustainability Standard. The standard and certification were created to deliver the most open and transparent means of evaluating and communicating the environmental and social impacts of furniture products in the built environment. Taking into account a company’s social actions, energy usage, material selection and human and ecosystem health impacts, LEVEL® addresses how a product is sustainable from multiple perspectives. The organization, facilities, and products are audited on an annual basis to ensure ongoing compliance and improvement.

With LEVEL®, customers can make informed choices about sustainable commercial office furniture. The LEVEL® mark identifies that a product has been vetted by an independent third party certifier and its numeric marking of 1, 2, or 3 indicates the threshold of certification the product has achieved. A majority of HBF’s seating, occasional tables, and conference lines are LEVEL® certified. Please download the certificates from our product pages for the complete details. For more information about the ANSI/BIFMA LEVEL® standard, visit www.levelcertified.org.

**ANSI/BIFMA Performance
Standards**

Our seating products meet or exceed ANSI/BIFMA weight performance standards of 275 lbs. (124.7 kg.) unless otherwise noted.

**Indoor Advantage™
Gold certified**

All HBF seating products are Indoor Advantage™ Gold certified.

SCS Global Services, a reputable third-party certification and assessment body of environmental, sustainability and safety claims since 1984, has developed internationally recognized standards and certification programs to assist businesses with improving their environmental efforts, social accountability and product performance.

The advantages of holding Indoor Air Quality certification are substantial: in addition to improving indoor working environments and meeting qualifications for the LEED-CI EQ 4.5 credit for office furniture as well as the BIFMA Standard for Low-Emitting Office Furniture Systems & Seating M-7.1, there is the added assurance of knowing that the company’s entire breadth of products is held to such rigorous standards.

For more information regarding Indoor Advantage™, please visit: <http://www.scsglobalservices.com>.

Please contact the HBF Client Experience Team for pricing and lead time information.

Dimension Guide

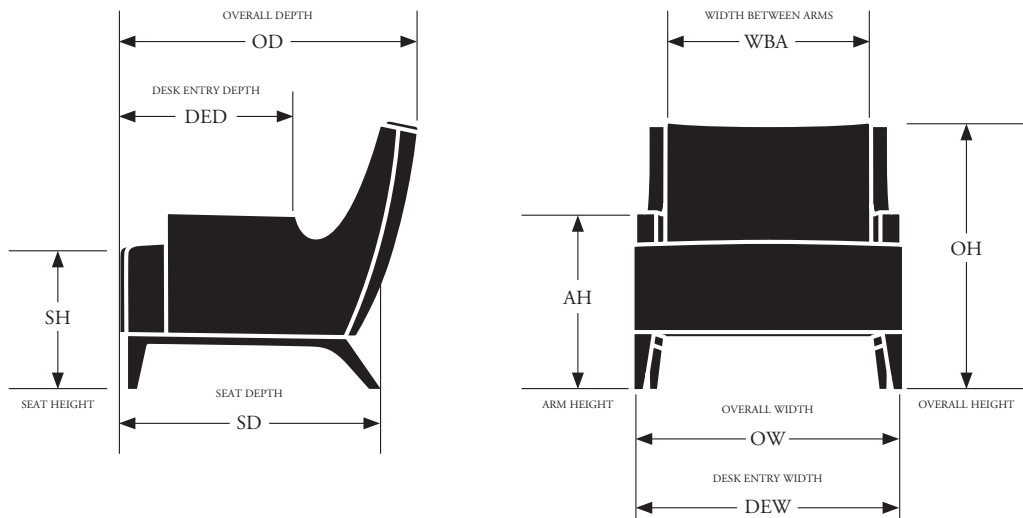



GSA/Federal Contract Information:

GSA Contract Number 47QSMA22D08P9

Model numbers identified with the following verbiage “When purchased separately without a configurable TAA compliant end product, not on GSA contract” is to mean that these configurable parts or components:

- Have no functionality or capability without being integrated into an end product; and
- Are considered **Open Market** if purchased without a configurable TAA compliant end product.

HBF High Performance Products

HBF and HBF Textiles have long been leaders in contract furnishings and known for industry-leading product design coupled with the highest quality construction, comfort and aesthetic beauty.

Now these same principals are the cornerstones of HBF Healthcare high performance products. We have consulted with healthcare designers and clients to provide products and options for interiors that will provide quality sustainable design solutions for the future. These effective solutions will address the unique interactions required by any high-use facility. Visit www.hbf.com for additional high performance product information.

Seating Product High Performance Options:

- Guest and Lounge Seating
- Arm Caps
- Moisture Barrier
- Wipe Out - Clean Out
- Tandem Seating
- Wall Saver Legs
- Replaceable Components
- Upholstery Products from HBF Textiles

Spring Down Cushions

Optional spring down cushions are available on most loose cushion HBF lounge seating. List upcharges are:

Chair	\$108
Loveseat	\$194
Sofa	\$297



POWDER COATS:

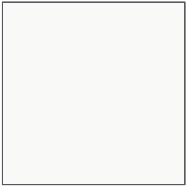

W1
White



LG
Light Grey



P8X
Solar Black

METAL:



POL
Polished Chrome

LAMINATES: (PL) Note: Available for modular table surfaces.

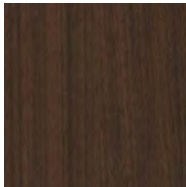

PL7943
Columbian Walnut

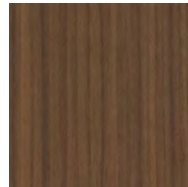

PL7965
Walnut Heights



PL8238
Fairchild



PLBW
Beigewood

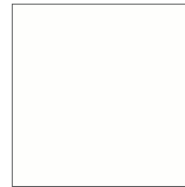

PLDW1
Designer White

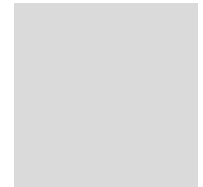

M11
Loft Grey Cloud



M16
Flint



PT1
Portico Teak

Screen images are intended as a guide only and should not be regarded as absolutely correct. For exact color/texture, please visit www.hbf.com to request an actual sample.



Grade A	Grade B	Grade C	Grade D	Grade E	Grade F
Blink Denim Wash* Walkabout Zippy	Look-see Remember Rush*	Caddy Corner* Checkmate Cuddle Up Picnic Plaid Upbeat	Chenille Striae Crumpled Paper Dot Grid Habu Poppy Skim Coat	Fourfold* Uptown	All Terrain Bunny Cloverleaf Comfort Zone Happy Camper Here & There Knitwork Laugh Lines Moody Moss Notable Grain Sherpa Well-Loved

Grade G	Grade H	Grade J	Grade K	Grade L	Grade M
Beetle Curtain Wall Dashing Equation* Folded Lines High Rise Honest* Inherent Matriarch Pebbled Scribble XS Stardust Upscale	Air Mail* Captain Bubble Crafted Felt Chubby Baby Intersection Lawn Chair Madam Dottie Soft Angles 2.0 Upstart Uptick	Abito Argyle Boucle Belgian Meadow Brushed Canvas Digital Bloom 2.0 Enriched Boucle Glint Lava Rock Quill Scribble XL Sir Stripe-a-lot Tattoo Toile Tessellations Tête-à-Tête Tickled Herring Twist	Afghan Cherished Knit Complex Crosstweed Double Stitch Gather Grateful Grid Heartfelt Merci Boucle Moving Blanket Moving Forward Night Earth Pepper Blend Polygone Quilted Comfort Sideways Sister Solid	Agate Stripe Goosebumps Hipster Landscape Blur Ms. Quilty 2.0 Smart* Sweater Velvet Mix Woven Memory	Crafted Cloud Eccentric Flirt Poodle

Leather I	Leather II	Leather III	Leather IV	Leather V	Leather VI
Clutch	Vivace II	Aviator	Free Way	Wild West	Modern Patina Upper Crust

*Some or all colors to be discontinued in 2024



Cityscape Specifications

Collection Details One Seat Lounge | Two Seat Lounge | Three Seat Lounge | Pentagon Ottoman | Square Ottoman
Upholstered

Base Metal Options Black Powder Coat | Grey Powder Coat | White Powder Coat | Polished Chrome

**Ganging Bracket
Leg Assembly Kit** Available. (Ordered separately)
Configuration Note: Ganging bracket leg kit is required when attaching any seat to any seat.

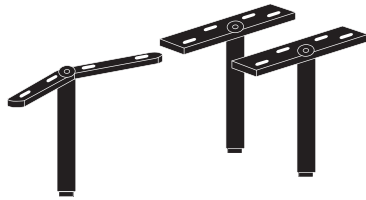

Fabric Placement

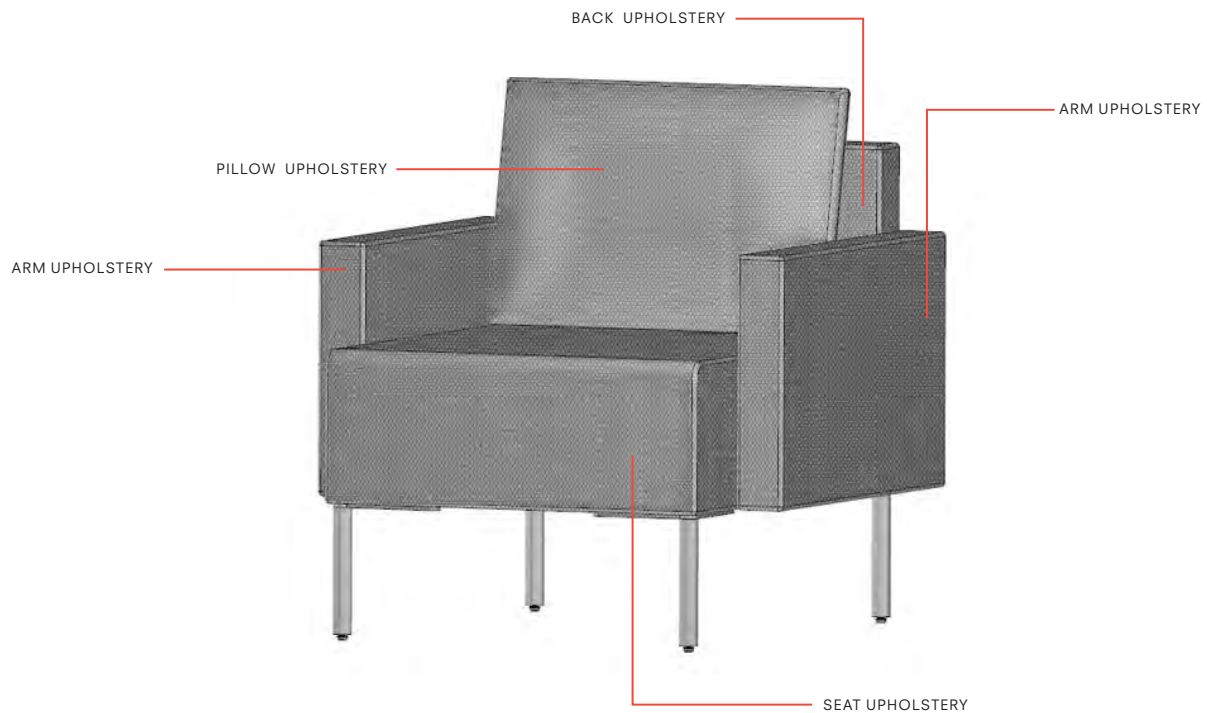

CITYSCAPE 2.0 FREESTANDING MODULE SEATING WITH ARMS

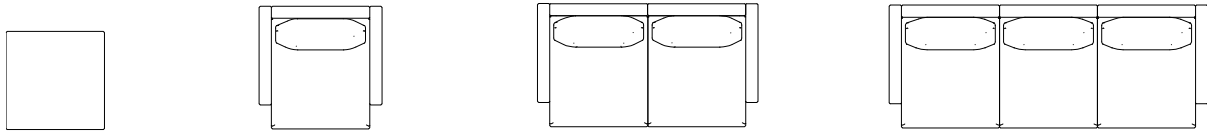
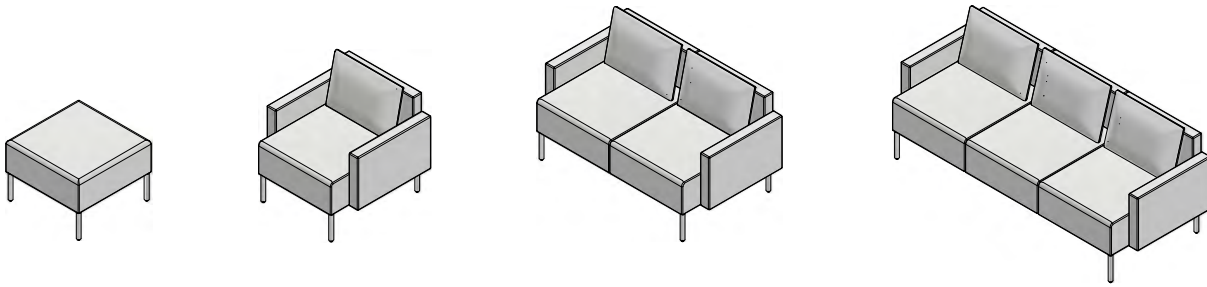

HLD421-044

HLD421-041

HLD421-042

HLD421-043

CITYSCAPE 2.0 FREESTANDING ARMLESS MODULE SEATING

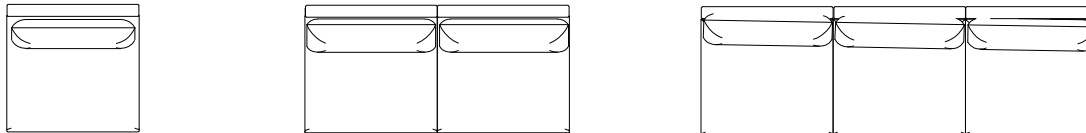
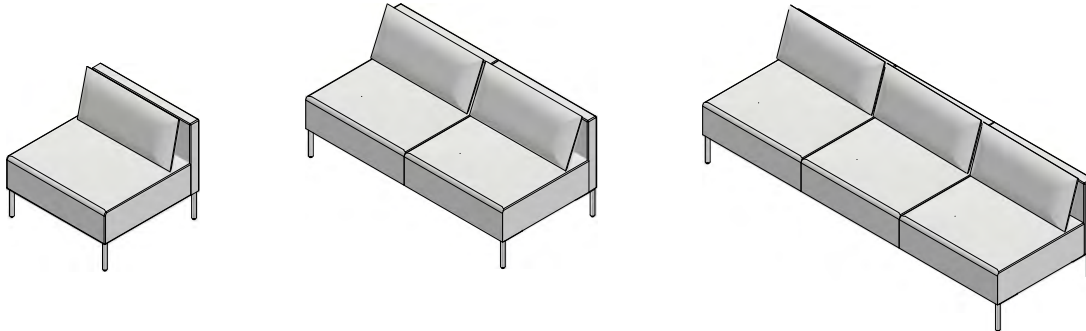

HLD421-021

HLD421-022

HLD421-023

CITYSCAPE 2.0 FREESTANDING PENTAGON UNITS

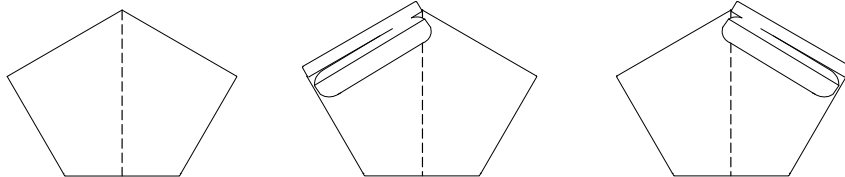
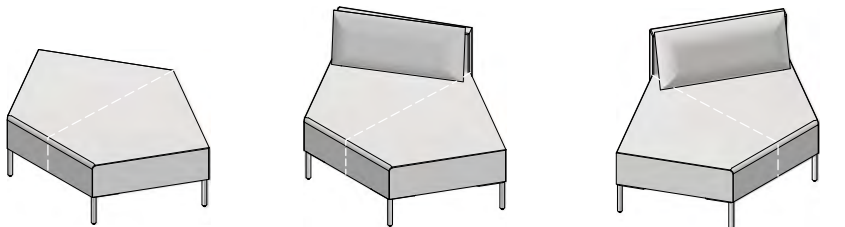

---- = Upholstery Seam

HLD421-014

HLD421-024

HLD421-034



CITYSCAPE 2.0 MODULAR RECTANGULAR CONNECTING TABLES

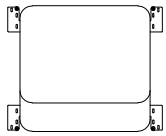
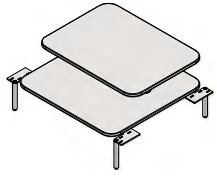

HTD42101-3231

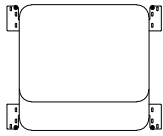
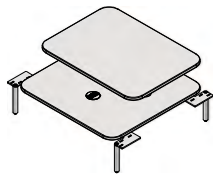

HTD42102-3231

CITYSCAPE 2.0 GANGING BRACKET LEG ASSEMBLY KIT

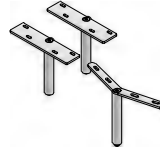

HAD421-010

CITYSCAPE 2.0 MODULAR RECTANGULAR CONNECTING TABLES WITH ROUND TOPS

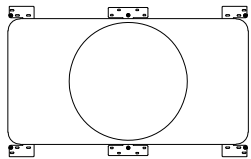
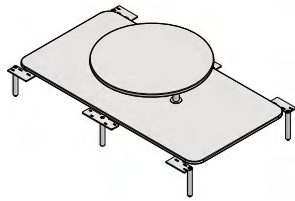

HTD42101-5931

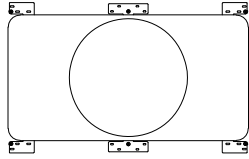
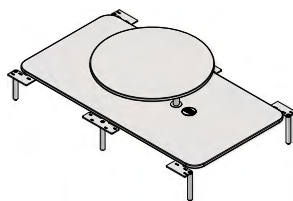

HTD42102-5931

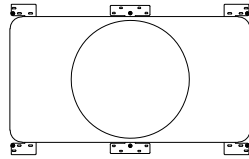
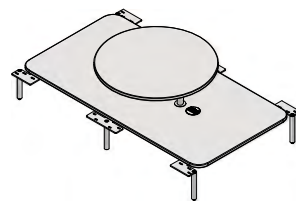

HTD42103-5931

CITYSCAPE 2.0 MODULAR DUAL-SIDED ADD-ON SEATING UNITS WITHOUT BACKS*

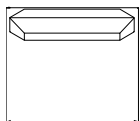
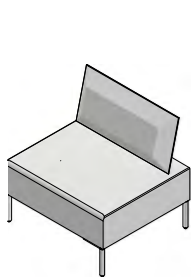

HLD421-011

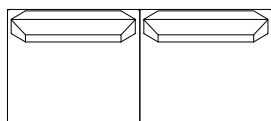
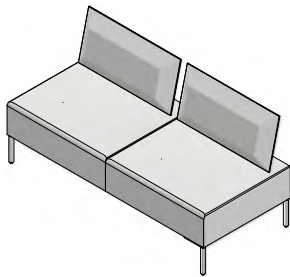

HLD421-012

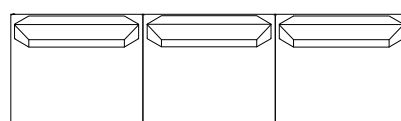
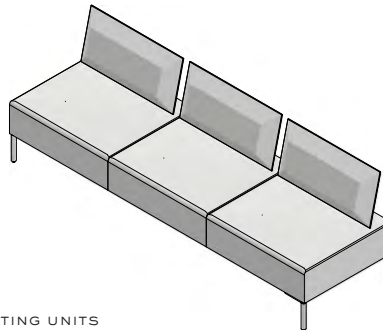

HLD421-013

*TO BE USED IN A SHARED BACK APPLICATION WITH FREESTANDING MODULAR SEATING UNITS

CONFIGURATION 1

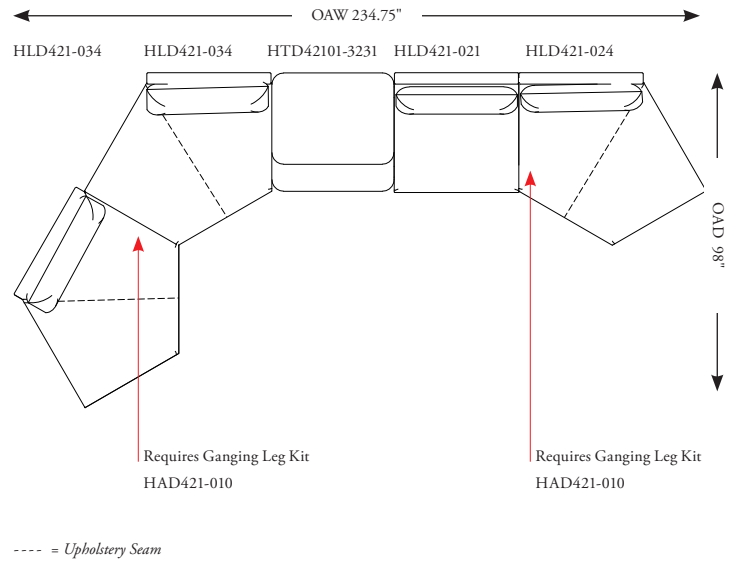
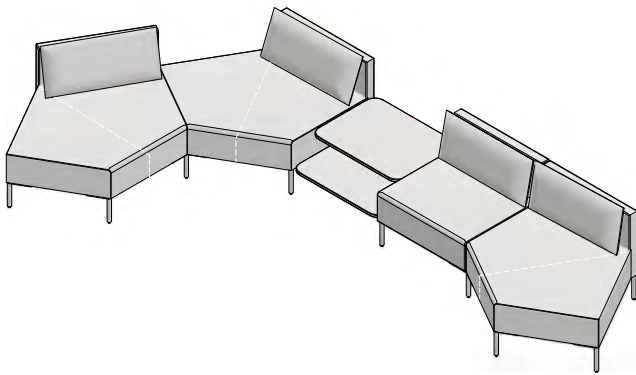

Notes:

Two extra HAD421-010 ganging bracket leg kits are required for this configuration type.

One seat modular (HLD421-021) can be interchanged with two seat modular (HLD421-022) or three seat modular (HLD421-023) at any location shown.

CONFIGURATION 2

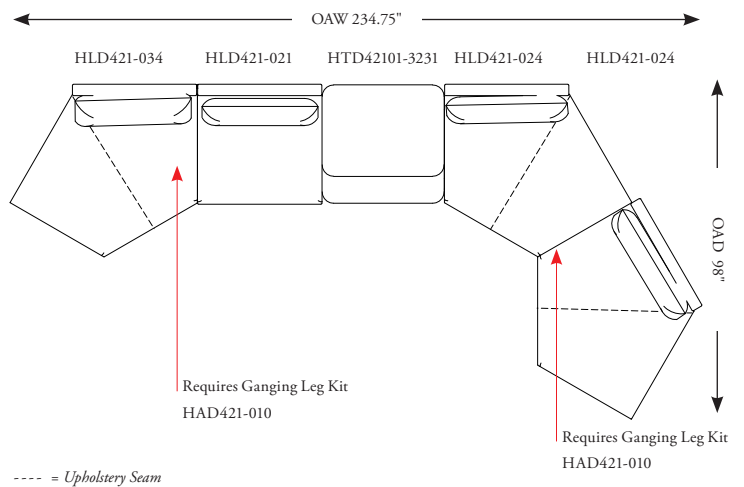
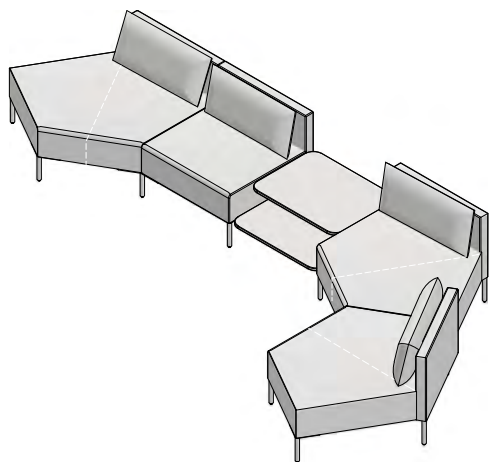

Notes:

Two extra HAD421-010 ganging bracket leg kits are required for this configuration type.

One seat modular (HLD421-021) can be interchanged with two seat modular (HLD421-022) or three seat modular (HLD421-023) at any location shown.

CONFIGURATION 3

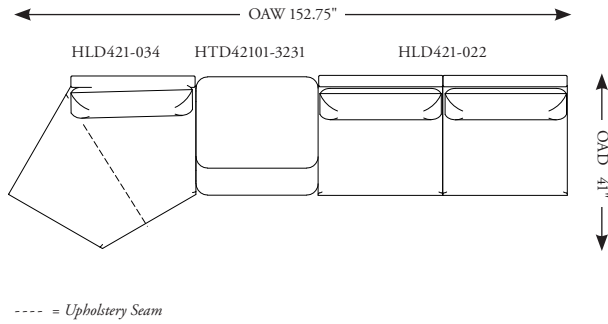
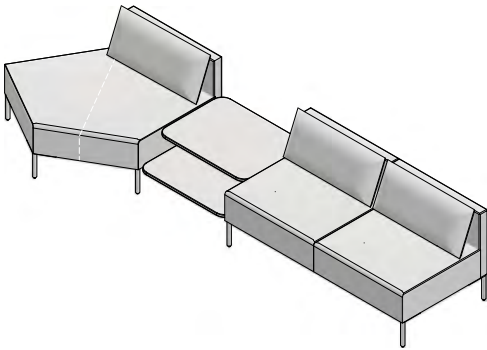

Notes:

Additional ganging bracket leg kits (HAD421-010) are not required for this configuration assembly.

Two seat modular (HLD421-022) can be interchanged with one seat modular (HLD421-021) or three seat modular (HLD421-023) at any location shown.

CONFIGURATION 4

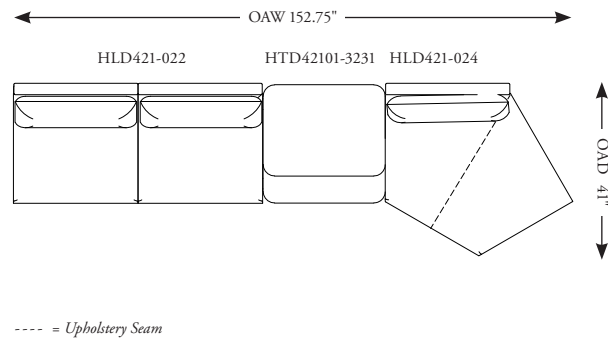
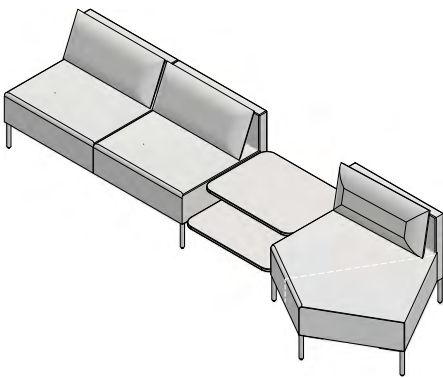

Notes:

Additional ganging bracket leg kits (HAD421-010) are not required for this configuration assembly.

Two seat modular (HLD421-022) can be interchanged with one seat modular (HLD421-021) or three seat modular (HLD421-023) at any location shown.

CONFIGURATION 5

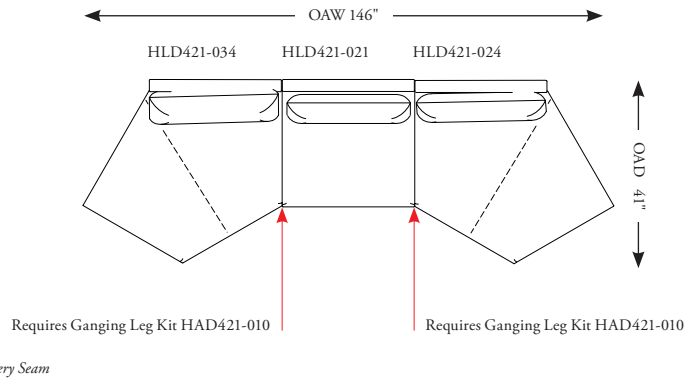
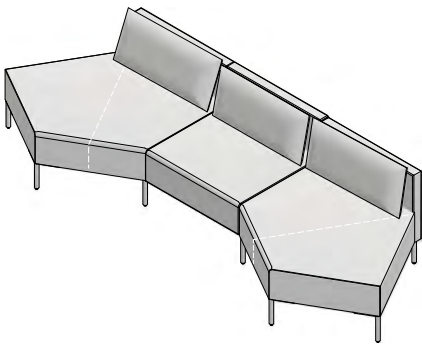

Notes:

- HLD421-021 can be interchanged with or added to HLD421-022 or HLD421-023 between HLD421-034 and HLD421-024.*
- Either HLD421-034 or HLD421-024 or both can be removed from this configuration.*
- This type of configuration cannot include back-to-back seating options.*
- Two extra HAD421-010 ganging bracket leg kits are required for this configuration type.*

CONFIGURATION 6

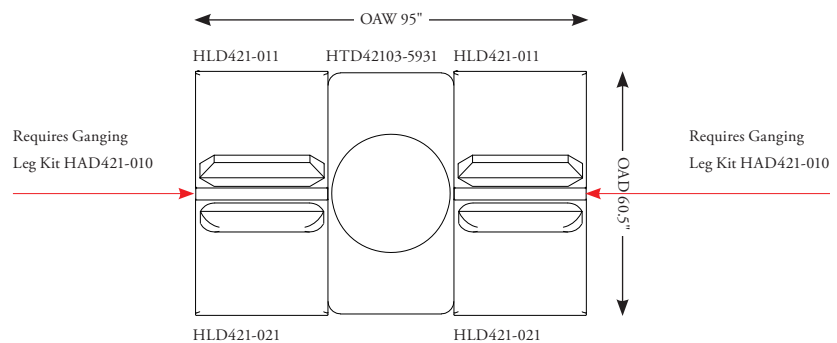
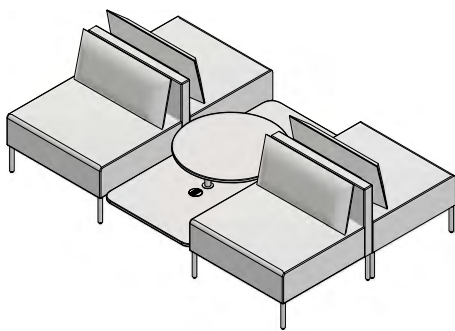

Notes:

- One seat modular (HLD421-021) can be interchanged with two seat modular (HLD421-022) or three seat modular (HLD421-023) at any location shown.*
- When using this type of configuration: HLD421-011 must attach to the back of HLD421-021*
- HLD421-012 must attach to the back of HLD421-022*
- HLD421-013 must attach to the back of HLD421-023*
- HTD42103-5931 table can be interchanged with HTD42101-5931 or HTD42102-5931 tables front to back as shown.*
- This type of configuration cannot have seating next to seating, a table must go between them.*
- Two additional ganging bracket leg kits (HAD421-010) are required for this configuration assembly.*

CITYSCAPE 2.0 General Dimensions

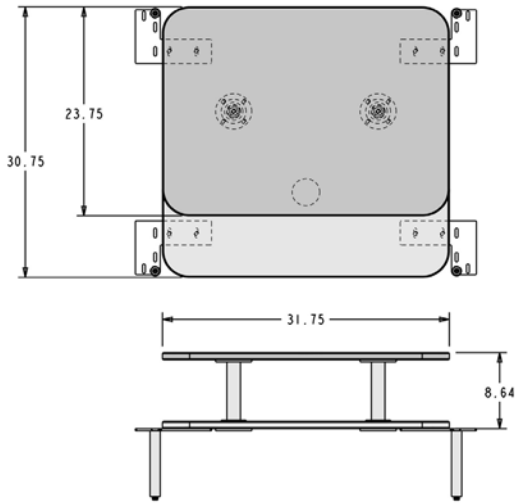

HTD42101-3231
HTD42102-3231

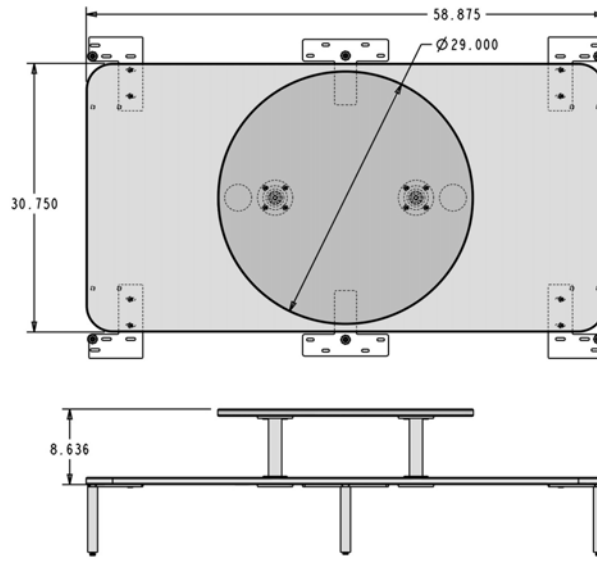

HTD42101-5931
HTD42102-5931
HTD42103-5931

CITYSCAPE 2.0 Power Location(s)

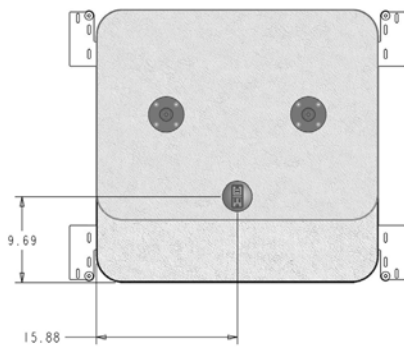

HTD42102-3231

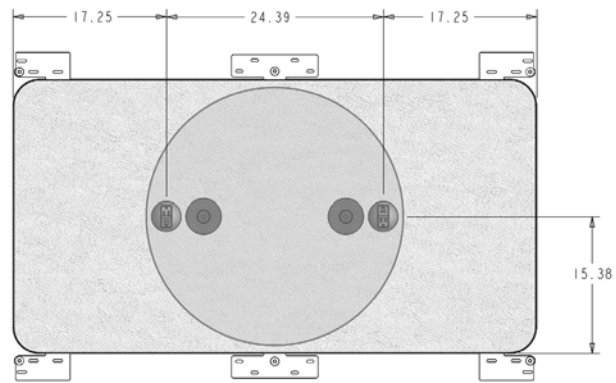

HTD42102-5931 with One Power Location
HTD42103-5931 with Two Power Locations

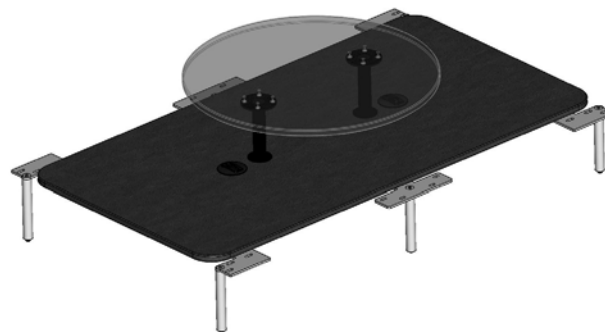



Dimensions

Cityscape 2.0 HLD421-021



OH	31½	AH
OW	32	WBA
OD	31½	DED
SH	17½	DEW
SD	28½	R

Shipping Weight 63
Cube 17.8

ANSI/BIFMA LEVEL® Furniture Sustainability Standard certified
Indoor Advantage™ certified

One Seat Lounge | No Arms | With Back | Pillow | Fully Upholstered | Metal Base

Configuration Note: Can be stand alone model

Pricing for Single Fabric Placement:

Upholstery:

COM/COL	2575
Grade A	2450
Grade B	2520
Grade C	2575
Grade D	2635
Grade E	2700
Grade F	2775
Grade G	2855
Grade H	2945
Grade J	3000
Grade K	3125
Grade L	3310
Grade M	3550
Leather I	3970
Leather II	4410
Leather III	4850
Leather IV	5290
Leather V	5730
Leather VI	6170

Upholstery Requires:

Fabric: 5½ Yards
Leather: 99 Sq. Ft.

Pricing for Multiple Fabric Placement:

(To Calculate, Begin with Base Price and add Upcharges)

Back Upholstery:

COM/COL	50
Grade A	15
Grade B	35
Grade C	50
Grade D	65
Grade E	85
Grade F	105
Grade G	125
Grade H	150
Grade J	165
Grade K	200
Grade L	250
Grade M	315
Leather I	430
Leather II	550
Leather III	670
Leather IV	790
Leather V	910
Leather VI	1030

Upholstery Requires (Per Application):

Fabric: 1½ Yards
Leather: 27 Sq. Ft.

Seat Upholstery:

COM/COL	80
Grade A	25
Grade B	55
Grade C	80
Grade D	110
Grade E	135
Grade F	170
Grade G	210
Grade H	250
Grade J	275
Grade K	330
Grade L	415
Grade M	525
Leather I	715
Leather II	915
Leather III	1115
Leather IV	1315
Leather V	1515
Leather VI	1715

Upholstery Requires (Per Application):

Fabric: 2½ Yards
Leather: 45 Sq. Ft.

Pillow Upholstery:

COM/COL	50
Grade A	15
Grade B	35
Grade C	50
Grade D	65
Grade E	85
Grade F	105
Grade G	125
Grade H	150
Grade J	165
Grade K	200
Grade L	250
Grade M	315
Leather I	430
Leather II	550
Leather III	670
Leather IV	790
Leather V	910
Leather VI	1030

Upholstery Requires (Per Application):

Fabric: 1½ Yards
Leather: 27 Sq. Ft.

Base Price: 2395

Total Required
Upholstery: Fabric: 5½ Yards
Leather: 99 Sq. Ft.

PLEASE SPECIFY THE FOLLOWING TO ORDER:

<p>MODEL NUMBER</p>	<p>TEXTILES</p> <p>Indicate fabric choice: Back</p> <p><i>See options for fabrics at www.hbftextiles.com</i></p>	<p>TEXTILES</p> <p>Indicate fabric choice: Seat</p> <p><i>See options for fabrics at www.hbftextiles.com</i></p>	<p>TEXTILES</p> <p>Indicate fabric choice: Pillow</p> <p><i>See options for fabrics at www.hbftextiles.com</i></p>	<p>FLAMMABILITY</p> <p>Indicate flammability:</p> <p><input type="checkbox"/> U = Cal 117</p>	<p>BASE FINISH</p> <p>Options for metal finish:</p> <p><input type="checkbox"/> P8X = Solar Black</p> <p><input type="checkbox"/> WI = White Powder Coat +\$50</p> <p><input type="checkbox"/> LG = Light Grey Powder Coat +\$50</p> <p><input type="checkbox"/> POL = Polished Chrome +\$200</p>
----------------------------	--	--	--	--	--

HLD421-021.FabBack.FabSeat.FabPillow.Flammability.Base Example: HLD421-021.950-88.950-88.950-88.U.P8X



Dimensions

Cityscape 2.0 HLD421-022



OH	31½	AH
OW	64	WBA
OD	31½	DED
SH	17½	DEW
SD	28½	R

Shipping Weight 104
Cube 43

ANSI/BIFMA LEVEL® Furniture Sustainability Standard certified
Indoor Advantage™ certified

Two Seat Lounge | No Arms | With Back | Pillow | Fully Upholstered | Metal Base

Configuration Note: Can be stand alone model

Pricing for Single Fabric Placement:

Upholstery:

COM/COL	3365
Grade A	3150
Grade B	3255
Grade C	3365
Grade D	3475
Grade E	3580
Grade F	3710
Grade G	3865
Grade H	4015
Grade J	4125
Grade K	4340
Grade L	4665
Grade M	5100
Leather I	5835
Leather II	6615
Leather III	7395
Leather IV	8175
Leather V	8955
Leather VI	9735

Upholstery Requires:

Fabric: 9¾ Yards
Leather: 175½ Sq. Ft.

Pricing for Multiple Fabric Placement:

(To Calculate, Begin with Base Price and add Upcharges)

Back Upholstery:

COM/COL	100
Grade A	35
Grade B	65
Grade C	100
Grade D	135
Grade E	165
Grade F	205
Grade G	255
Grade H	300
Grade J	335
Grade K	400
Grade L	500
Grade M	635
Leather I	860
Leather II	1100
Leather III	1340
Leather IV	1580
Leather V	1820
Leather VI	2060

Upholstery Requires (Per Application):

Fabric: 3 Yards
Leather: 54 Sq. Ft.

Seat Upholstery:

COM/COL	130
Grade A	45
Grade B	85
Grade C	130
Grade D	175
Grade E	220
Grade F	275
Grade G	335
Grade H	400
Grade J	445
Grade K	530
Grade L	665
Grade M	845
Leather I	1145
Leather II	1465
Leather III	1785
Leather IV	2105
Leather V	2425
Leather VI	2745

Upholstery Requires (Per Application):

Fabric: 4 Yards
Leather: 72 Sq. Ft.

Pillow Upholstery:

COM/COL	95
Grade A	30
Grade B	65
Grade C	95
Grade D	125
Grade E	155
Grade F	190
Grade G	235
Grade H	275
Grade J	305
Grade K	370
Grade L	460
Grade M	580
Leather I	790
Leather II	1010
Leather III	1230
Leather IV	1450
Leather V	1670
Leather VI	1890

Upholstery Requires (Per Application):

Fabric: 2¾ Yards
Leather: 49½ Sq. Ft.

Base Price: 3040

Total Required

Upholstery: Fabric: 9¾ Yards
Leather: 175½ Sq. Ft.

PLEASE SPECIFY THE FOLLOWING TO ORDER:

<p>MODEL NUMBER</p>	<p>TEXTILES</p> <p>Indicate fabric choice: Back</p> <p><i>See options for fabrics at www.hbf textiles.com</i></p>	<p>TEXTILES</p> <p>Indicate fabric choice: Seat</p> <p><i>See options for fabrics at www.hbf textiles.com</i></p>	<p>TEXTILES</p> <p>Indicate fabric choice: Pillow</p> <p><i>See options for fabrics at www.hbf textiles.com</i></p>	<p>FLAMMABILITY</p> <p>Indicate flammability:</p> <p><input type="checkbox"/> U = Cal 117</p>	<p>BASE FINISH</p> <p>Options for metal finish:</p> <p><input type="checkbox"/> P8X = Solar Black</p> <p><input type="checkbox"/> WI = White Powder Coat +\$50</p> <p><input type="checkbox"/> LG = Light Grey Powder Coat +\$50</p> <p><input type="checkbox"/> POL = Polished Chrome +\$200</p>
----------------------------	--	--	--	--	--

HLD421-022.FabBack.FabSeat.FabPillow.Flammability.Base Example: HLD421-022.950-88.950-88.950-88.U.P8X



Dimensions

Cityscape 2.0 HLD421-023



OH	31½	AH
OW	96	WBA
OD	31½	DED
SH	17½	DEW
SD	28½	R

Shipping Weight 159
Cube 63.6

ANSI/BIFMA LEVEL® Furniture Sustainability Standard certified
Indoor Advantage™ certified

Three Seat Lounge | No Arms | With Back | Pillow | Fully Upholstered | Metal Base

Configuration Note: Can be stand alone model

Pricing for Single Fabric Placement:

Upholstery:

COM/COL	4995
Grade A	4695
Grade B	4845
Grade C	4995
Grade D	5145
Grade E	5295
Grade F	5475
Grade G	5685
Grade H	5895
Grade J	6045
Grade K	6345
Grade L	6795
Grade M	7395
Leather I	8415
Leather II	9495
Leather III	10,575
Leather IV	11,655
Leather V	12,735
Leather VI	13,815

Upholstery Requires:

Fabric: 13½ Yards
Leather: 243 Sq. Ft.

Pricing for Multiple Fabric Placement:

(To Calculate, Begin with Base Price and add Upcharges)

Back Upholstery:

COM/COL	150
Grade A	50
Grade B	100
Grade C	150
Grade D	200
Grade E	250
Grade F	310
Grade G	380
Grade H	450
Grade J	500
Grade K	600
Grade L	750
Grade M	950
Leather I	1290
Leather II	1650
Leather III	2010
Leather IV	2370
Leather V	2730
Leather VI	3090

Upholstery Requires (Per Application):

Fabric: 4½ Yards
Leather: 81 Sq. Ft.

Seat Upholstery:

COM/COL	175
Grade A	60
Grade B	115
Grade C	175
Grade D	235
Grade E	290
Grade F	360
Grade G	445
Grade H	525
Grade J	585
Grade K	700
Grade L	875
Grade M	1110
Leather I	1505
Leather II	1925
Leather III	2345
Leather IV	2765
Leather V	3185
Leather VI	3605

Upholstery Requires (Per Application):

Fabric: 5¼ Yards
Leather: 94½ Sq. Ft.

Pillow Upholstery:

COM/COL	125
Grade A	40
Grade B	85
Grade C	125
Grade D	165
Grade E	210
Grade F	260
Grade G	315
Grade H	375
Grade J	415
Grade K	500
Grade L	625
Grade M	790
Leather I	1075
Leather II	1375
Leather III	1675
Leather IV	1975
Leather V	2275
Leather VI	2575

Upholstery Requires (Per Application):

Fabric: 3¾ Yards
Leather: 67½ Sq. Ft.

Base Price: 4545

Total Required
Upholstery: Fabric: 13½ Yards
Leather: 243 Sq. Ft.

PLEASE SPECIFY THE FOLLOWING TO ORDER:

<p>MODEL NUMBER</p>	<p>TEXTILES</p> <p>Indicate fabric choice: Back</p> <p><i>See options for fabrics at www.hbf textiles.com</i></p>	<p>TEXTILES</p> <p>Indicate fabric choice: Seat</p> <p><i>See options for fabrics at www.hbf textiles.com</i></p>	<p>TEXTILES</p> <p>Indicate fabric choice: Pillow</p> <p><i>See options for fabrics at www.hbf textiles.com</i></p>	<p>FLAMMABILITY</p> <p>Indicate flammability:</p> <p><input type="checkbox"/> U = Cal 117</p>	<p>BASE FINISH</p> <p>Options for metal finish:</p> <p><input type="checkbox"/> P8X = Solar Black</p> <p><input type="checkbox"/> WI = White Powder Coat +\$50</p> <p><input type="checkbox"/> LG = Light Grey Powder Coat +\$50</p> <p><input type="checkbox"/> POL = Polished Chrome +\$200</p>
----------------------------	--	--	--	--	--

HLD421-023.FabBack.FabSeat.FabPillow.Flammability.Base Example: HLD421-023.950-88.950-88.950-88.U.P8X



Dimensions

Cityscape 2.0 HLD421-011



OH	17½	AH
OW	32	WBA
OD	28½	DED
SH	17½	DEW
SD	28½	R

Shipping Weight	49
Cube	17.8

Dual-Side Add-On Unit | One Seat Lounge | No Arms | No Back | Pillow | Fully Upholstered | Metal Base | Pillow Clips

ANSI/BIFMA LEVEL® Furniture Sustainability Standard certified
Indoor Advantage™ certified

Note: To be used in a shared application with freestanding modular seating unit HLD421-021.

Configuration Note: Cannot be stand alone model and must be attached back-to-back with HLD421-021.

Dual-sided seating cannot attach to the pentagons.

Dual-sided seating cannot attach to another dual-sided seating configuration unless connecting table models are added in between.
Model HTD42101-5931, HTD42102-5931 or HTD42103-5931 must go in between.

Pricing for Single Fabric Placement:

Upholstery:

COM/COL	1975
Grade A	1885
Grade B	1935
Grade C	1975
Grade D	2020
Grade E	2065
Grade F	2120
Grade G	2180
Grade H	2245
Grade J	2285
Grade K	2375
Grade L	2510
Grade M	2685
Leather I	2990
Leather II	3310
Leather III	3630
Leather IV	3950
Leather V	4270
Leather VI	4590

Upholstery Requires:

Fabric: 4 Yards
Leather: 72 Sq. Ft.

Pricing for Multiple Fabric Placement:

(To Calculate, Begin with Base Price and add Upcharges)

Seat Upholstery:

COM/COL	80
Grade A	25
Grade B	55
Grade C	80
Grade D	110
Grade E	135
Grade F	170
Grade G	210
Grade H	250
Grade J	275
Grade K	330
Grade L	415
Grade M	525
Leather I	715
Leather II	915
Leather III	1115
Leather IV	1315
Leather V	1515
Leather VI	1715

Upholstery Requires (Per Application):

Fabric: 2½ Yards
Leather: 45 Sq. Ft.

Pillow Upholstery:

COM/COL	50
Grade A	15
Grade B	35
Grade C	50
Grade D	65
Grade E	85
Grade F	105
Grade G	125
Grade H	150
Grade J	165
Grade K	200
Grade L	250
Grade M	315
Leather I	430
Leather II	550
Leather III	670
Leather IV	790
Leather V	910
Leather VI	1030

Upholstery Requires (Per Application):

Fabric: 1½ Yards
Leather: 27 Sq. Ft.Base Price: **1845**Total Required
Upholstery: Fabric: 4 Yards
Leather: 72 Sq. Ft.

PLEASE SPECIFY THE FOLLOWING TO ORDER:

MODEL NUMBER	TEXTILES Indicate fabric choice: Seat See options for fabrics at www.hbftextiles.com	TEXTILES Indicate fabric choice: Pillow See options for fabrics at www.hbftextiles.com	FLAMMABILITY Indicate flammability: U = Cal 117	BASE FINISH Options for metal finish: P8X = Solar Black WI = White Powder Coat +\$50 LG = Light Grey Powder Coat +\$50 POL = Polished Chrome +\$200
--------------	--	--	---	--

HLD421-011.FabSeat.FabPillow.Flammability.Base Example: HLD421-011.950-88.950-88.U.P8X



Dimensions

Cityscape 2.0 HLD421-012



OH	17½	AH
OW	64	WBA
OD	28½	DED
SH	17½	DEW
SD	28½	R

Shipping Weight	84
Cube	35.6

Dual-Side Add-On Unit | Two Seat Lounge | No Arms | No Back | Pillow | Fully Upholstered | Metal Base | Pillow Clips

ANSI/BIFMA LEVEL® Furniture Sustainability Standard certified
Indoor Advantage™ certified

Note: To be used in a shared application with freestanding modular seating unit HLD421-022.

Configuration Note: Cannot be stand alone model and must be attached back-to-back with HLD421-022.

Dual-sided seating cannot attach to the pentagons.

Dual-sided seating cannot attach to another dual-sided seating configuration unless connecting table models are added in between.
Model HTD42101-5931, HTD42102-5931 or HTD42103-5931 must go in between.

Pricing for Single Fabric Placement:

Upholstery:

COM/COL	2830
Grade A	2680
Grade B	2755
Grade C	2830
Grade D	2905
Grade E	2980
Grade F	3070
Grade G	3175
Grade H	3280
Grade J	3355
Grade K	3505
Grade L	3730
Grade M	4030
Leather I	4540
Leather II	5080
Leather III	5620
Leather IV	6160
Leather V	6700
Leather VI	7240

Upholstery Requires:

Fabric: 6¾ Yards
Leather: 121½ Sq. Ft.

Pricing for Multiple Fabric Placement:

(To Calculate, Begin with Base Price and add Upcharges)

Seat Upholstery:

COM/COL	130
Grade A	45
Grade B	85
Grade C	130
Grade D	175
Grade E	220
Grade F	275
Grade G	335
Grade H	400
Grade J	445
Grade K	530
Grade L	665
Grade M	845
Leather I	1145
Leather II	1465
Leather III	1785
Leather IV	2105
Leather V	2425
Leather VI	2745

Upholstery Requires (Per Application):

Fabric: 4 Yards
Leather: 72 Sq. Ft.

Pillow Upholstery:

COM/COL	95
Grade A	30
Grade B	65
Grade C	95
Grade D	125
Grade E	155
Grade F	190
Grade G	235
Grade H	275
Grade J	305
Grade K	370
Grade L	460
Grade M	580
Leather I	790
Leather II	1010
Leather III	1230
Leather IV	1450
Leather V	1670
Leather VI	1890

Upholstery Requires (Per Application):

Fabric: 2¾ Yards
Leather: 49½ Sq. Ft.Base Price: 2605Total Required
Upholstery: Fabric: 6¾ Yards
Leather: 121½ Sq. Ft.

PLEASE SPECIFY THE FOLLOWING TO ORDER:

MODEL NUMBER	TEXTILES Indicate fabric choice: Seat See options for fabrics at www.hbf textiles.com	TEXTILES Indicate fabric choice: Pillow See options for fabrics at www.hbf textiles.com	FLAMMABILITY Indicate flammability: U = Cal 117	BASE FINISH Options for metal finish: P8X = Solar Black WI = White Powder Coat +\$50 LG = Light Grey Powder Coat +\$50 POL = Polished Chrome +\$200
--------------	---	---	---	--

HLD421-012.FabSeat.FabPillow.Flammability.Base Example: HLD421-012.950-88.950-88.U.P8X



Dimensions

Cityscape 2.0 HLD421-013



OH	17½	AH
OW	96	WBA
OD	28½	DED
SH	17½	DEW
SD	28½	R

Shipping Weight	117
Cube	50.7

Dual-Side Add-On Unit | Three Seat Lounge | No Arms | No Back | Pillow | Fully Upholstered | Metal Base | Pillow Clips

ANSI/BIFMA LEVEL® Furniture Sustainability Standard certified
Indoor Advantage™ certified

Note: To be used in a shared application with freestanding modular seating unit HLD421-023.

Configuration Note: Cannot be stand alone model and must be attached back-to-back with HLD421-023.

Dual-sided seating cannot attach to the pentagons.

Dual-sided seating cannot attach to another dual-sided seating configuration unless connecting table models are added in between.
Model HTD42101-5931, HTD42102-5931 or HTD42103-5931 must go in between.

Pricing for Single Fabric Placement:

Upholstery:

COM/COL	3380
Grade A	3180
Grade B	3280
Grade C	3380
Grade D	3480
Grade E	3580
Grade F	3700
Grade G	3840
Grade H	3980
Grade J	4080
Grade K	4280
Grade L	4580
Grade M	4980
Leather I	5660
Leather II	6380
Leather III	7100
Leather IV	7820
Leather V	8540
Leather VI	9260

Upholstery Requires:

Fabric: 9 Yards
Leather: 162 Sq. Ft.

Pricing for Multiple Fabric Placement:

(To Calculate, Begin with Base Price and add Upcharges)

Seat Upholstery:

COM/COL	175
Grade A	60
Grade B	115
Grade C	175
Grade D	235
Grade E	290
Grade F	360
Grade G	445
Grade H	525
Grade J	585
Grade K	700
Grade L	875
Grade M	1110
Leather I	1505
Leather II	1925
Leather III	2345
Leather IV	2765
Leather V	3185
Leather VI	3605

Upholstery Requires (Per Application):

Fabric: 5¼ Yards
Leather: 94½ Sq. Ft.

Pillow Upholstery:

COM/COL	125
Grade A	40
Grade B	85
Grade C	125
Grade D	165
Grade E	210
Grade F	260
Grade G	315
Grade H	375
Grade J	415
Grade K	500
Grade L	625
Grade M	790
Leather I	1075
Leather II	1375
Leather III	1675
Leather IV	1975
Leather V	2275
Leather VI	2575

Upholstery Requires (Per Application):

Fabric: 3¾ Yards
Leather: 67½ Sq. Ft.Base Price: Total Required
Upholstery: Fabric: 9 Yards
Leather: 162 Sq. Ft.

PLEASE SPECIFY THE FOLLOWING TO ORDER:

MODEL NUMBER	TEXTILES Indicate fabric choice: Seat See options for fabrics at www.hbf textiles.com	TEXTILES Indicate fabric choice: Pillow See options for fabrics at www.hbf textiles.com	FLAMMABILITY Indicate flammability: U = Cal 117	BASE FINISH Options for metal finish: P8X = Solar Black WI = White Powder Coat +\$50 LG = Light Grey Powder Coat +\$50 POL = Polished Chrome +\$200
--------------	---	---	---	--

HLD421-013.FabSeat.FabPillow.Flammability.Base Example: HLD421-013.950-88.950-88.U.P8X



Dimensions

Cityscape 2.0 HLD421-024

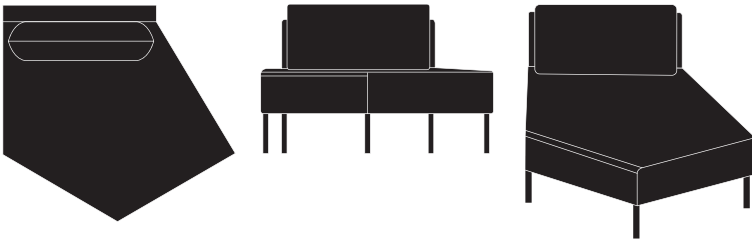

OH	31½	AH	
OW	57	SW	48
OD	41	DED	
SH	17½	DEW	
SD	31	R	
Shipping Weight		92	
Cube		63.6	

ANSI/BIFMA LEVEL® Furniture Sustainability Standard certified
Indoor Advantage™ certified

Pentagon Chaise Lounge | No Arms | With LSF Back | Pillow | Fully Upholstered | Metal Base

Configuration Notes: Can be stand alone model.

Dual-sided seating cannot attach to the pentagons.

Pricing for Single Fabric Placement:

Upholstery:

COM/COL	2885
Grade A	2750
Grade B	2820
Grade C	2885
Grade D	2950
Grade E	3020
Grade F	3100
Grade G	3190
Grade H	3285
Grade J	3350
Grade K	3485
Grade L	3685
Grade M	3950
Leather I	4405
Leather II	4885
Leather III	5365
Leather IV	5845
Leather V	6325
Leather VI	6805

Upholstery Requires:

Fabric: 6 Yards
Leather: 108 Sq. Ft.

Pricing for Multiple Fabric Placement:

(To Calculate, Begin with Base Price and add Upcharges)

Back Upholstery:

COM/COL	50
Grade A	15
Grade B	35
Grade C	50
Grade D	65
Grade E	85
Grade F	105
Grade G	125
Grade H	150
Grade J	165
Grade K	200
Grade L	250
Grade M	315
Leather I	430
Leather II	550
Leather III	670
Leather IV	790
Leather V	910
Leather VI	1030

Upholstery Requires (Per Application):

Fabric: 1½ Yards
Leather: 27 Sq. Ft.

Seat Upholstery:

COM/COL	100
Grade A	35
Grade B	65
Grade C	100
Grade D	135
Grade E	165
Grade F	205
Grade G	255
Grade H	300
Grade J	335
Grade K	400
Grade L	500
Grade M	635
Leather I	860
Leather II	1100
Leather III	1340
Leather IV	1580
Leather V	1820
Leather VI	2060

Upholstery Requires (Per Application):

Fabric: 3 Yards
Leather: 54 Sq. Ft.

Pillow Upholstery:

COM/COL	50
Grade A	15
Grade B	35
Grade C	50
Grade D	65
Grade E	85
Grade F	105
Grade G	125
Grade H	150
Grade J	165
Grade K	200
Grade L	250
Grade M	315
Leather I	430
Leather II	550
Leather III	670
Leather IV	790
Leather V	910
Leather VI	1030

Upholstery Requires (Per Application):

Fabric: 1½ Yards
Leather: 27 Sq. Ft.

Base Price: 2685

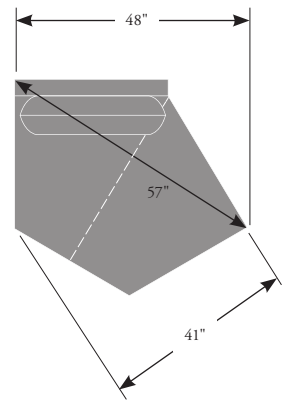

Total Required Upholstery: Fabric: 6 Yards
Leather: 108 Sq. Ft.

PLEASE SPECIFY THE FOLLOWING TO ORDER:

MODEL NUMBER	TEXTILES Indicate fabric choice: Back <i>See options for fabrics at www.hbftextiles.com</i>	TEXTILES Indicate fabric choice: Seat <i>See options for fabrics at www.hbftextiles.com</i>	TEXTILES Indicate fabric choice: Pillow <i>See options for fabrics at www.hbftextiles.com</i>	FLAMMABILITY Indicate flammability: U = Cal 117	BASE FINISH Options for metal finish: P8X = Solar Black WI = White Powder Coat +\$50 LG = Light Grey Powder Coat +\$50 POL = Polished Chrome +\$200
--------------	---	---	---	---	--

HLD421-024.FabBack.FabSeat.FabPillow.Flammability.Base Example: HLD421-024.950-88.950-88.950-88.U.P8X



Dimensions

Cityscape 2.0 HLD421-034



OH	31½	AH	
OW	57	SW	48
OD	41	DED	
SH	17½	DEW	
SD	31	R	
Shipping Weight		92	
Cube		63.6	

Pentagon Chaise Lounge | No Arms | With RSF Back | Pillow | Fully Upholstered | Metal Base

ANSI/BIFMA LEVEL® Furniture Sustainability Standard certified
Indoor Advantage™ certified

Configuration Notes: Can be stand alone model.

Dual-sided seating cannot attach to the pentagons.

Pricing for Single Fabric Placement:

Upholstery:

COM/COL	2885
Grade A	2750
Grade B	2820
Grade C	2885
Grade D	2950
Grade E	3020
Grade F	3100
Grade G	3190
Grade H	3285
Grade J	3350
Grade K	3485
Grade L	3685
Grade M	3950
Leather I	4405
Leather II	4885
Leather III	5365
Leather IV	5845
Leather V	6325
Leather VI	6805

Upholstery Requires:

Fabric: 6 Yards
Leather: 108 Sq. Ft.

Pricing for Multiple Fabric Placement:

(To Calculate, Begin with Base Price and add Upcharges)

Back Upholstery:

COM/COL	50
Grade A	15
Grade B	35
Grade C	50
Grade D	65
Grade E	85
Grade F	105
Grade G	125
Grade H	150
Grade J	165
Grade K	200
Grade L	250
Grade M	315
Leather I	430
Leather II	550
Leather III	670
Leather IV	790
Leather V	910
Leather VI	1030

Upholstery Requires (Per Application):

Fabric: 1½ Yards
Leather: 27 Sq. Ft.

Seat Upholstery:

COM/COL	100
Grade A	35
Grade B	65
Grade C	100
Grade D	135
Grade E	165
Grade F	205
Grade G	255
Grade H	300
Grade J	335
Grade K	400
Grade L	500
Grade M	635
Leather I	860
Leather II	1100
Leather III	1340
Leather IV	1580
Leather V	1820
Leather VI	2060

Upholstery Requires (Per Application):

Fabric: 3 Yards
Leather: 54 Sq. Ft.

Pillow Upholstery:

COM/COL	50
Grade A	15
Grade B	35
Grade C	50
Grade D	65
Grade E	85
Grade F	105
Grade G	125
Grade H	150
Grade J	165
Grade K	200
Grade L	250
Grade M	315
Leather I	430
Leather II	550
Leather III	670
Leather IV	790
Leather V	910
Leather VI	1030

Upholstery Requires (Per Application):

Fabric: 1½ Yards
Leather: 27 Sq. Ft.

Base Price: 2685

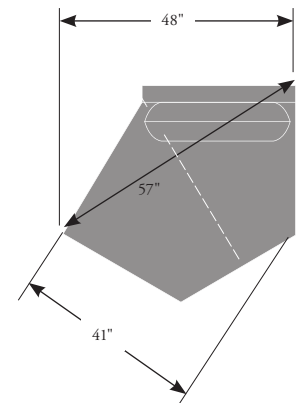

Total Required Upholstery: Fabric: 6 Yards
Leather: 108 Sq. Ft.

PLEASE SPECIFY THE FOLLOWING TO ORDER:

MODEL NUMBER	TEXTILES Indicate fabric choice: Back <i>See options for fabrics at www.hbftextiles.com</i>	TEXTILES Indicate fabric choice: Seat <i>See options for fabrics at www.hbftextiles.com</i>	TEXTILES Indicate fabric choice: Pillow <i>See options for fabrics at www.hbftextiles.com</i>	FLAMMABILITY Indicate flammability: U = Cal 117	BASE FINISH Options for metal finish: P8X = Solar Black WI = White Powder Coat +\$50 LG = Light Grey Powder Coat +\$50 POL = Polished Chrome +\$200
--------------	--	--	--	---	--

HLD421-034.FabBack.FabSeat.FabPillow.Flammability.Base Example: HLD421-034.950-88.950-88.950-88.U.P8X



Dimensions

Cityscape 2.0 HLD421-041

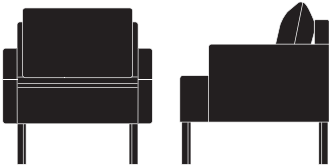

OH	32	AH	23
OW	30	WBA	24
OD	30	DED	
SH	17½	DEW	
SD	19½	R	

Shipping Weight 70
Cube 20.2

ANSI/BIFMA LEVEL® Furniture Sustainability Standard certified
Indoor Advantage™ certified

Armchair | Pillow | Fully Upholstered | Metal Base

Configuration Notes: Stand alone model only and does not attach

Pricing for Single Fabric Placement:

Pricing for Multiple Fabric Placement:
(To Calculate, Begin with Base Price and add Upcharges)

Base Price: 3185

Upholstery:

COM/COL	3410
Grade A	3260
Grade B	3335
Grade C	3410
Grade D	3480
Grade E	3565
Grade F	3655
Grade G	3750
Grade H	3860
Grade J	3935
Grade K	4085
Grade L	4310
Grade M	4610
Leather I	5120
Leather II	5660
Leather III	6200
Leather IV	6740
Leather V	7280
Leather VI	7820

Back Upholstery:

COM/COL	50
Grade A	15
Grade B	35
Grade C	50
Grade D	65
Grade E	85
Grade F	105
Grade G	125
Grade H	150
Grade J	165
Grade K	200
Grade L	250
Grade M	315
Leather I	430
Leather II	550
Leather III	670
Leather IV	790
Leather V	910
Leather VI	1030

Arm Upholstery:

COM/COL	70
Grade A	25
Grade B	45
Grade C	70
Grade D	90
Grade E	115
Grade F	140
Grade G	170
Grade H	200
Grade J	225
Grade K	270
Grade L	335
Grade M	425
Leather I	575
Leather II	735
Leather III	895
Leather IV	1055
Leather V	1215
Leather VI	1375

Seat Upholstery:

COM/COL	55
Grade A	20
Grade B	35
Grade C	55
Grade D	75
Grade E	95
Grade F	120
Grade G	145
Grade H	175
Grade J	195
Grade K	230
Grade L	290
Grade M	370
Leather I	500
Leather II	640
Leather III	780
Leather IV	920
Leather V	1060
Leather VI	1200

Pillow Upholstery:

COM/COL	50
Grade A	15
Grade B	35
Grade C	50
Grade D	65
Grade E	85
Grade F	105
Grade G	125
Grade H	150
Grade J	165
Grade K	200
Grade L	250
Grade M	315
Leather I	430
Leather II	550
Leather III	670
Leather IV	790
Leather V	910
Leather VI	1030

Upholstery Requires:

Fabric: 6¾ Yards
Leather: 121½ Sq. Ft.

Upholstery Requires (Per Application):

Fabric: 1½ Yards
Leather: 27 Sq. Ft.

Upholstery Requires (Per Application):

Fabric: 2 Yards
Leather: 36 Sq. Ft.

Upholstery Requires (Per Application):

Fabric: 1¾ Yards
Leather: 31½ Sq. Ft.

Upholstery Requires (Per Application):

Fabric: 1½ Yards
Leather: 27 Sq. Ft.

Total Required
Upholstery: Fabric: 6¾ Yards
Leather: 121½ Sq. Ft.

PLEASE SPECIFY THE FOLLOWING TO ORDER:

MODEL NUMBER	TEXTILES	TEXTILES	TEXTILES	TEXTILES	FLAMMABILITY	BASE FINISH
	Indicate fabric choice: Back	Indicate fabric choice: Arm	Indicate fabric choice: Seat	Indicate fabric choice: Pillow	Indicate flammability:	Options for metal finish:
	See options for fabrics at www.hbf textiles.com	See options for fabrics at www.hbf textiles.com	See options for fabrics at www.hbf textiles.com	See options for fabrics at www.hbf textiles.com	U = Cal 117	P8X = Solar Black WI = White Powder Coat +\$50 LG = Light Grey Powder Coat +\$50 POL = Polished Chrome +\$200

HLD421-041.FabBack.FabArm.FabSeat.FabPillow.Flammability.Base Example: HLD421-041.950-88.950-88.950-88.950-88.U.P8X



Dimensions

Cityscape 2.0 HLD421-042



OH	32	AH	23
OW	54	WBA	48
OD	30	DED	
SH	17½	DEW	
SD	19½	R	

Shipping Weight 110
Cube 33

ANSI/BIFMA LEVEL® Furniture Sustainability Standard certified
Indoor Advantage™ certified

Two Seat Sofa | Pillow | Fully Upholstered | Metal Base

Configuration Notes: Stand alone model only and does not attach

Pricing for Single Fabric Placement:

Pricing for Multiple Fabric Placement:
(To Calculate, Begin with Base Price and add Upcharges)

Base Price: 4325

Upholstery:

COM/COL	4605
Grade A	4420
Grade B	4510
Grade C	4605
Grade D	4700
Grade E	4795
Grade F	4910
Grade G	5040
Grade H	5175
Grade J	5270
Grade K	5455
Grade L	5740
Grade M	6120
Leather I	6760
Leather II	7440
Leather III	8120
Leather IV	8800
Leather V	9480
Leather VI	10,160

Back Upholstery:

COM/COL	75
Grade A	25
Grade B	50
Grade C	75
Grade D	100
Grade E	125
Grade F	155
Grade G	190
Grade H	225
Grade J	250
Grade K	300
Grade L	375
Grade M	475
Leather I	645
Leather II	825
Leather III	1005
Leather IV	1185
Leather V	1365
Leather VI	1545

Arm Upholstery:

COM/COL	70
Grade A	25
Grade B	45
Grade C	70
Grade D	90
Grade E	115
Grade F	140
Grade G	170
Grade H	200
Grade J	225
Grade K	270
Grade L	335
Grade M	425
Leather I	575
Leather II	735
Leather III	895
Leather IV	1055
Leather V	1215
Leather VI	1375

Seat Upholstery:

COM/COL	80
Grade A	25
Grade B	55
Grade C	80
Grade D	110
Grade E	135
Grade F	170
Grade G	210
Grade H	250
Grade J	275
Grade K	330
Grade L	415
Grade M	525
Leather I	715
Leather II	915
Leather III	1115
Leather IV	1315
Leather V	1515
Leather VI	1715

Pillow Upholstery:

COM/COL	55
Grade A	20
Grade B	35
Grade C	55
Grade D	75
Grade E	95
Grade F	120
Grade G	145
Grade H	175
Grade J	195
Grade K	230
Grade L	290
Grade M	370
Leather I	500
Leather II	640
Leather III	780
Leather IV	920
Leather V	1060
Leather VI	1200

Upholstery Requires:

Fabric: 8½ Yards
Leather: 153 Sq. Ft.

Upholstery Requires (Per Application):

Fabric: 2¼ Yards
Leather: 40½ Sq. Ft.

Upholstery Requires (Per Application):

Fabric: 2 Yards
Leather: 36 Sq. Ft.

Upholstery Requires (Per Application):

Fabric: 2½ Yards
Leather: 45 Sq. Ft.

Upholstery Requires (Per Application):

Fabric: 1¾ Yards
Leather: 31½ Sq. Ft.

Total Required

Upholstery: Fabric: 8½ Yards
Leather: 153 Sq. Ft.

PLEASE SPECIFY THE FOLLOWING TO ORDER:

MODEL NUMBER	TEXTILES	TEXTILES	TEXTILES	TEXTILES	FLAMMABILITY	BASE FINISH
	Indicate fabric choice: Back	Indicate fabric choice: Arm	Indicate fabric choice: Seat	Indicate fabric choice: Pillow	Indicate flammability:	Options for metal finish:
	<i>See options for fabrics at www.hbf textiles.com</i>	<i>See options for fabrics at www.hbf textiles.com</i>	<i>See options for fabrics at www.hbf textiles.com</i>	<i>See options for fabrics at www.hbf textiles.com</i>	U = Cal 117	P8X = Solar Black WI = White Powder Coat +\$50 LG = Light Grey Powder Coat +\$50 POL = Polished Chrome +\$200

HLD421-042.FabBack.FabArm.FabSeat.FabPillow.Flammability.Base Example: HLD421-042.950-88.950-88.950-88.950-88.U.P8X



Dimensions

Cityscape 2.0 HLD421-043



OH	32	AH	23
OW	78	WBA	72
OD	30	DED	
SH	17½	DEW	
SD	19½	R	

Shipping Weight 142
Cube 48

ANSI/BIFMA LEVEL® Furniture Sustainability Standard certified
Indoor Advantage™ certified

Three Seat Sofa | Pillow | Fully Upholstered | Metal Base

Configuration Notes: Stand alone model only and does not attach

Pricing for Single Fabric Placement:

Pricing for Multiple Fabric Placement:
(To Calculate, Begin with Base Price and add Upcharges)

Base Price: 5260

Upholstery:

COM/COL	5665
Grade A	5395
Grade B	5530
Grade C	5665
Grade D	5805
Grade E	5940
Grade F	6100
Grade G	6295
Grade H	6485
Grade J	6620
Grade K	6890
Grade L	7300
Grade M	7845
Leather I	8770
Leather II	9750
Leather III	10,730
Leather IV	11,710
Leather V	12,690
Leather VI	13,670

Back Upholstery:

COM/COL	105
Grade A	35
Grade B	70
Grade C	105
Grade D	145
Grade E	180
Grade F	220
Grade G	275
Grade H	325
Grade J	360
Grade K	430
Grade L	540
Grade M	685
Leather I	930
Leather II	1190
Leather III	1450
Leather IV	1710
Leather V	1970
Leather VI	2230

Arm Upholstery:

COM/COL	70
Grade A	25
Grade B	45
Grade C	70
Grade D	90
Grade E	115
Grade F	140
Grade G	170
Grade H	200
Grade J	225
Grade K	270
Grade L	335
Grade M	425
Leather I	575
Leather II	735
Leather III	895
Leather IV	1055
Leather V	1215
Leather VI	1375

Seat Upholstery:

COM/COL	155
Grade A	50
Grade B	105
Grade C	155
Grade D	210
Grade E	260
Grade F	325
Grade G	400
Grade H	475
Grade J	525
Grade K	630
Grade L	790
Grade M	1000
Leather I	1360
Leather II	1740
Leather III	2120
Leather IV	2500
Leather V	2880
Leather VI	3260

Pillow Upholstery:

COM/COL	75
Grade A	25
Grade B	50
Grade C	75
Grade D	100
Grade E	125
Grade F	155
Grade G	190
Grade H	225
Grade J	250
Grade K	300
Grade L	375
Grade M	475
Leather I	645
Leather II	825
Leather III	1005
Leather IV	1185
Leather V	1365
Leather VI	1545

Upholstery Requires:

Fabric: 12¼ Yards
Leather: 220½ Sq. Ft.

Upholstery Requires (Per Application):

Fabric: 3¼ Yards
Leather: 58½ Sq. Ft.

Upholstery Requires (Per Application):

Fabric: 2 Yards
Leather: 36 Sq. Ft.

Upholstery Requires (Per Application):

Fabric: 4¾ Yards
Leather: 85½ Sq. Ft.

Upholstery Requires (Per Application):

Fabric: 2¼ Yards
Leather: 40½ Sq. Ft.

Total Required
Upholstery: Fabric: 12¼ Yards
Leather: 220½ Sq. Ft.

PLEASE SPECIFY THE FOLLOWING TO ORDER:

MODEL NUMBER	TEXTILES	TEXTILES	TEXTILES	TEXTILES	FLAMMABILITY	BASE FINISH
	Indicate fabric choice: Back	Indicate fabric choice: Arm	Indicate fabric choice: Seat	Indicate fabric choice: Pillow	Indicate flammability:	Options for metal finish:
	See options for fabrics at www.hbf textiles.com	See options for fabrics at www.hbf textiles.com	See options for fabrics at www.hbf textiles.com	See options for fabrics at www.hbf textiles.com	U = Cal 117	<ul style="list-style-type: none"> P8X = Solar Black WI = White Powder Coat +\$50 LG = Light Grey Powder Coat +\$50 POL = Polished Chrome +\$200

HLD421-043.FabBack.FabArm.FabSeat.FabPillow.Flammability.Base Example: HLD421-043.950-88.950-88.950-88.950-88.U.P8X

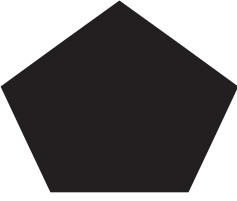

	List Prices				Sq.Ft.	Yards	Dimensions				
Cityscape 2.0 HLD421-014											
	COM/COL	2540	Grade G	2695	Leather I	3300	54	3	OH	17½	AH
	Grade A	2475	Grade H	2740	Leather II	3540			OW	57	WBA
	Grade B	2505	Grade J	2775	Leather III	3780			OD	41	DED
	Grade C	2540	Grade K	2840	Leather IV	4020			SH	17½	DEW
	Grade D	2575	Grade L	2940	Leather V	4260			SD	41	R
	Grade E	2605	Grade M	3075	Leather VI	4500					
	Grade F	2645									
									Shipping Weight	70	
									Cube	31	



Pentagon Ottoman | No Arms | No Back | Fully Upholstered | Metal Base

ANSI/BIFMA LEVEL® Furniture Sustainability Standard certified
Indoor Advantage™ certified

*Configuration Notes: Can be stand alone model.
Dual-sided seating cannot attach to the pentagons.*

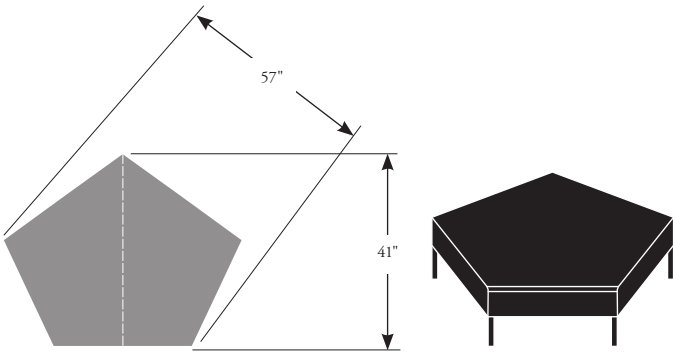

PLEASE SPECIFY THE FOLLOWING TO ORDER:

MODEL NUMBER	TEXTILES	FLAMMABILITY	BASE FINISH
	Indicate fabric choice: Seat <i>See options for fabrics at www.hbftextiles.com</i>	Indicate flammability: U = Cal 117	Options for metal finish: P8X = Solar Black WI = White Powder Coat +\$50 LG = Light Grey Powder Coat +\$50 POL = Polished Chrome +\$200

HLD421-014.FabSeat.Flammability.Base Example: HLD421-014.950-88.U.P8X



	List Prices				Sq.Ft.	Yards	Dimensions			
Cityscape 2.0 HLD421-044										
	COM/COL	1865	Grade G	2070	Leather I	2880	72	4	OH 17½	AH
	Grade A	1780	Grade H	2135	Leather II	3200			OW 24	WBA
	Grade B	1820	Grade J	2180	Leather III	3520			OD 24	DED
	Grade C	1865	Grade K	2265	Leather IV	3840			SH 17½	DEW
	Grade D	1910	Grade L	2400	Leather V	4160			SD 24	R
	Grade E	1955	Grade M	2580	Leather VI	4480				
	Grade F	2010							Shipping Weight	35
									Cube	16

Square Ottoman | No Arms | No Back | Fully Upholstered | Metal Base

ANSI/BIFMA LEVEL® Furniture Sustainability Standard certified
Indoor Advantage™ certified

Configuration Notes: Stand alone model only and does not attach

PLEASE SPECIFY THE FOLLOWING TO ORDER:

MODEL NUMBER	TEXTILES	FLAMMABILITY	BASE FINISH
	Indicate fabric choice: Seat <i>See options for fabrics at www.hbftextiles.com</i>	Indicate flammability: U = Cal 117	Options for metal finish: P8X = Solar Black WI = White Powder Coat +\$50 LG = Light Grey Powder Coat +\$50 POL = Polished Chrome +\$200

HLD421-044.FabSeat.Flammability.Base Example: HLD421-044.950-88.U.P8X



Style Number	Description	List Price	Shipping Weight	Cube
Cityscape 2.0 Ganging Leg Kit				
HAD421-010	Bracket Kit	540		



Note: Depending on configuration, all ganging legs may not be used.

PLEASE SPECIFY THE FOLLOWING TO ORDER: _____

MODEL NUMBER	BASE FINISH
	Options for metal finish:
	<input type="checkbox"/> P8X = Solar Black
	<input type="checkbox"/> WI = White Powder Coat
	<input type="checkbox"/> LG = Light Grey Powder Coat
	<input type="checkbox"/> POL = Polished Chrome

HAD421-010.Base Example: HAD421-010.P8X

Cityscape 2.0 Modular Connecting Tables Specifications

Surface	Laminate
Metal	Black Powder Coat Light Grey Powder Coat White Powder Coat Polished Chrome
Power Data Options	Available

Power Options (1 Power Receptacle and 1 USB-2 amps per port)



HVD71901N-110
Black Powder Coat,
Black Simplex



HVD71902N-110
White Powder Coat,
White Simplex



HVD71903N-110
Trichrome
Black Simplex



HVD71904N-110
Trichrome
White Simplex

CITYSCAPE 2.0 Power Location(s)

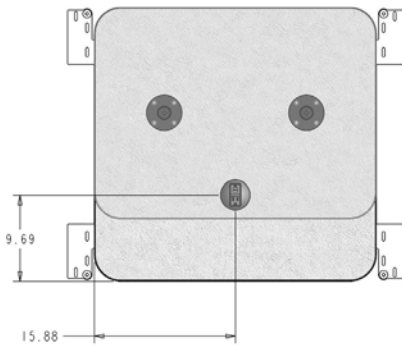

HTD42102-3231

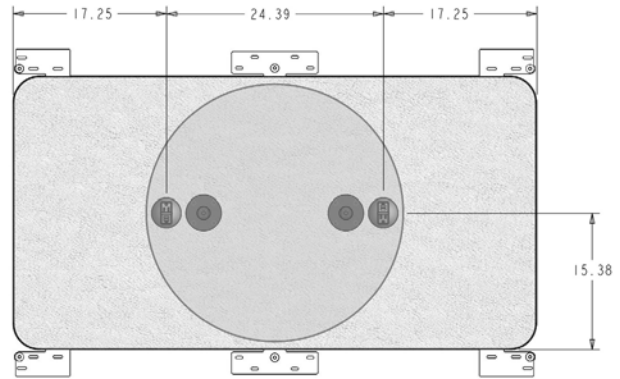

HTD42102-5931 with One Power Location
HTD42103-5931 with Two Power Locations

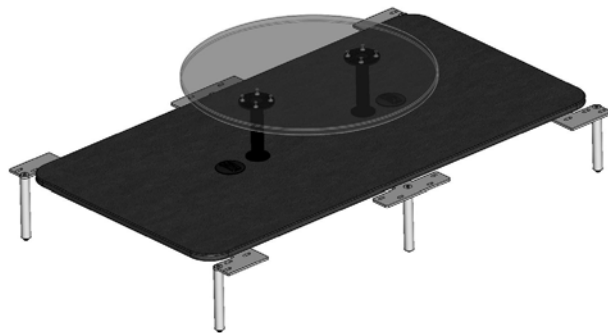



Cityscape 2.0 Modular Rectangular Connecting Table

Style Number	Top Description	List Price	Two Tables per Set	Shipping Weight	Cube
HTD42101-3231	<i>Laminate</i>	2,510	<i>Top:</i> W 31¾ D 23¾ H 8½ <i>Bottom:</i> W 31¾ D 30¾ H 22½ <i>Overall Height:</i> 31	64	10.79

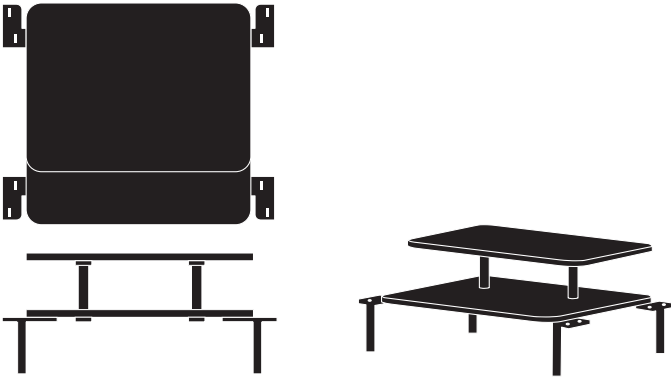

Rectangular Top Table | Rectangular Bottom Table | Metal Legs

ANSI/BIFMA LEVEL® Furniture Sustainability Standard certified
Indoor Advantage™ certified

Configuration Notes: Connecting tables cannot be set up as a standalone model or configured on an end of seating row.

Dual-sided seating cannot attach to another dual-sided seating configuration unless connecting table models are added in between. Model HTD42101-5931, HTD42102-5931 or HTD42103-5931 must go in between.

PLEASE SPECIFY THE FOLLOWING TO ORDER: _____

MODEL NUMBER	TOP	BASE FINISH
	Options for laminate finishes: PL = Laminat 7943 = Columbian Walnut 7965 = Walnut Heights 8238 = Fairchild BW = Beigewood DW1 = Designer White M11 = Loft Grey Cloud M16 = Flint PT1 = Portico Teak	Options for metal leg finish: P8X = Solar Black W1 = White Powder Coat +\$50 LG = Light Grey Powder Coat +\$50 POL = Polished Chrome +\$200

HTD42101-3231.Top.Base Example: HTD42101-3231.PLBW.P8X



Cityscape 2.0 Modular Rectangular Connecting Table with Round Top

Style Number	Top Description	List Price	Two Tables per Set	Shipping Weight	Cube
HTD42101-5931	<i>Laminate</i>	3,365	<i>Top:</i> Dia 29 H 8½ <i>Bottom:</i> W 58¾ D 30¾ H 22½ <i>Overall Height:</i> 31	92	18.67

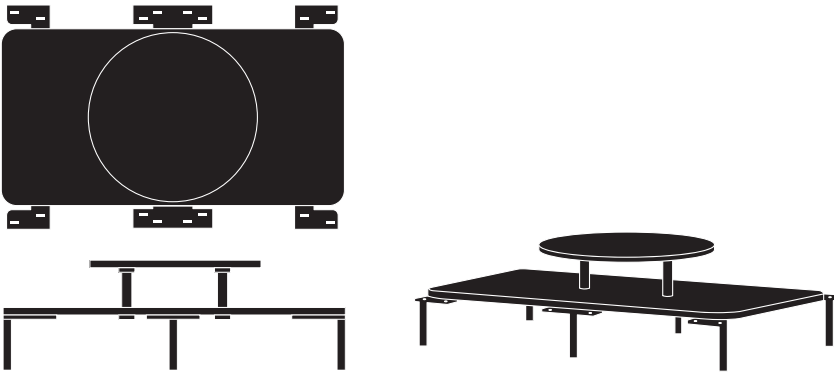

Round Top Table | Rectangular Bottom Table | Metal Legs

ANSI/BIFMA LEVEL® Furniture Sustainability Standard certified
Indoor Advantage™ certified

Configuration Notes: Connecting tables cannot be set up as a standalone model or configured on an end of seating row.

Dual-sided seating cannot attach to another dual-sided seating configuration unless connecting table models are added in between. Model HTD42101-5931, HTD42102-5931 or HTD42103-5931 must go in between.

PLEASE SPECIFY THE FOLLOWING TO ORDER: _____

MODEL NUMBER	TOP	BASE FINISH
	Options for laminate finishes: PL = Laminat 7943 = Columbian Walnut 7965 = Walnut Heights 8238 = Fairchild BW = Beigewood DW1 = Designer White M11 = Loft Grey Cloud M16 = Flint PT1 = Portico Teak	Options for metal leg finish: P8X = Solar Black W1 = White Powder Coat +\$50 LG = Light Grey Powder Coat +\$50 POL = Polished Chrome +\$200

HTD42101-5931.Top.Base Example: HTD42101-5931.PLBW.P8X



Cityscape 2.0 Modular Rectangular Connecting Table with Power Capability

Style Number	Top Description	List Price	Two Tables per Set	Shipping Weight	Cube
HTD42102-3231	<i>Laminate</i>	2,625	<i>Top:</i> W 31¾ D 23¾ H 8½ <i>Bottom:</i> W 31¾ D 30¾ H 22½ <i>Overall Height:</i> 31	64	10.79

Note: One powerConnect module must be ordered separately (see page 36 for power options).

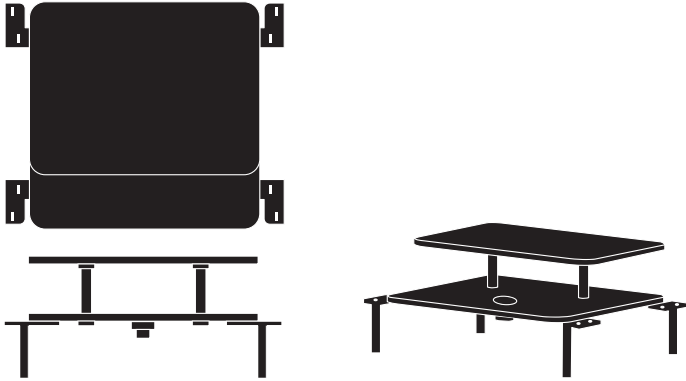

Rectangular Top Table | Rectangular Bottom Table | Metal Legs | Power Capability

ANSI/BIFMA LEVEL® Furniture Sustainability Standard certified
Indoor Advantage™ certified

Configuration Notes: Connecting tables cannot be set up as a standalone model or configured on an end of seating row.

Dual-sided seating cannot attach to another dual-sided seating configuration unless connecting table models are added in between. Model HTD42101-5931, HTD42102-5931 or HTD42103-5931 must go in between.

PLEASE SPECIFY THE FOLLOWING TO ORDER: _____

MODEL NUMBER	TOP	BASE FINISH
	Options for laminate finishes: PL = Laminate 7943 = Columbian Walnut 7965 = Walnut Heights 8238 = Fairchild BW = Beigewood DW1 = Designer White M11 = Loft Grey Cloud M16 = Flint PT1 = Portico Teak	Options for metal leg finish: P8X = Solar Black W1 = White Powder Coat +\$50 LG = Light Grey Powder Coat +\$50 POL = Polished Chrome +\$200

HTD42102-3231.Top.Base Example: HTD42102-3231.PLBW.P8X



Cityscape 2.0 Modular Connecting Table with Round Top and Power Capability

Style Number	Top Description	List Price	Two Tables per Set	Shipping Weight	Cube
HTD42102-5931	<i>Laminate</i>	3,490	<i>Top: Dia 29 H 8½</i> <i>Bottom: W 58¾ D 30¾ H 22½</i> <i>Overall Height: 31</i>	92	18.67

Note: One powerConnect module must be ordered separately (see page 36 for power options).

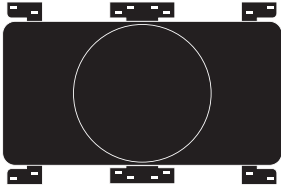

Round Top Table | Rectangular Bottom Table | Metal Legs | Power Capability

ANSI/BIFMA LEVEL® Furniture Sustainability Standard certified
Indoor Advantage™ certified

Configuration Notes: Connecting tables cannot be set up as a standalone model or configured on an end of seating row.

Dual-sided seating cannot attach to another dual-sided seating configuration unless connecting table models are added in between. Model HTD42101-5931, HTD42102-5931 or HTD42103-5931 must go in between.

PLEASE SPECIFY THE FOLLOWING TO ORDER: _____

MODEL NUMBER	TOP	BASE FINISH
	Options for laminate finishes: PL = Laminate 7943 = Columbian Walnut 7965 = Walnut Heights 8238 = Fairchild BW = Beigewood DW1 = Designer White M11 = Loft Grey Cloud M16 = Flint PT1 = Portico Teak	Options for metal leg finish: P8X = Solar Black W1 = White Powder Coat +\$50 LG = Light Grey Powder Coat +\$50 POL = Polished Chrome +\$200

HTD42102-5931.Top.Base Example: HTD42102-5931.PLBW.P8X



Cityscape 2.0 Modular Connecting Table with Round Top and Power Capability

Style Number	Top Description	List Price	Two Tables per Set	Shipping Weight	Cube
HTD42103-5931	<i>Laminate</i>	3,610	<i>Top:</i> Dia 29 H 8½ <i>Bottom:</i> W 58¾ D 30¾ H 22½ <i>Overall Height:</i> 31	92	18.67

Note: Two powerConnect modules must be ordered separately (see page 36 for power options).

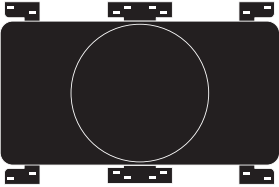

Round Top Table | Rectangular Bottom Table | Metal Legs | Power Capability

ANSI/BIFMA LEVEL® Furniture Sustainability Standard certified
Indoor Advantage™ certified

Configuration Notes: Connecting tables cannot be set up as a standalone model or configured on an end of seating row.

Dual-sided seating cannot attach to another dual-sided seating configuration unless connecting table models are added in between. Model HTD42101-5931, HTD42102-5931 or HTD42103-5931 must go in between.

PLEASE SPECIFY THE FOLLOWING TO ORDER: _____

MODEL NUMBER	TOP	BASE FINISH
	Options for laminate finishes: PL = Laminate 7943 = Columbian Walnut 7965 = Walnut Heights 8238 = Fairchild BW = Beigewood DW1 = Designer White M11 = Loft Grey Cloud M16 = Flint PT1 = Portico Teak	Options for metal leg finish: P8X = Solar Black W1 = White Powder Coat +\$50 LG = Light Grey Powder Coat +\$50 POL = Polished Chrome +\$200

HTD42103-5931.Top.Base Example: HTD42103-5931.PLBW.P8X



Model	Description	Dimensions Diameter	List Price
POWERCONNECT			
HVD71901N-110	1 receptacle & 1 dual USB; Black powder coat; Black simplex		385
HVD71902N-110	1 receptacle & 1 dual USB; White powder coat; White simplex		385
HVD71903N-110	1 receptacle & 1 dual USB; Trichrome; Black simplex		455
HVD71904N-110	1 receptacle & 1 dual USB; Trichrome; White simplex		415

Power Options (1 Power Receptacle and 1 USB-2 amps per port), 72" cord



HVD71901N-110
Black Powder Coat,
Black Simplex



HVD71902N-110
White Powder Coat,
White Simplex



HVD71903N-110
Trichrome
Black Simplex



HVD71904N-110
Trichrome
White Simplex

CITYSCAPE 2.0 Power Location(s)

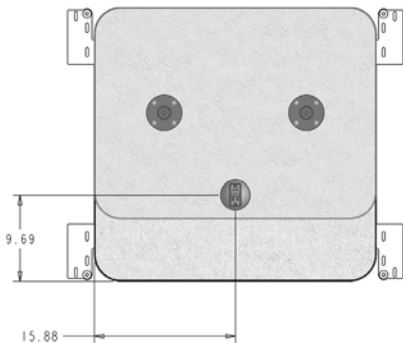

HTD42102-3231

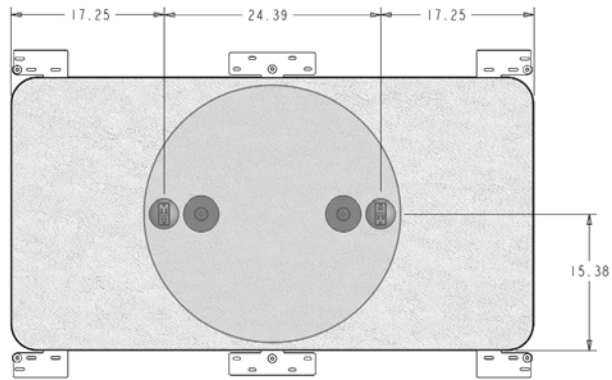

HTD42102-5931 with One Power Location
HTD42103-5931 with Two Power Locations

