

# BRIEFING™

## INSTALLATION INSTRUCTIONS

---

### TABLE OF CONTENTS

- RIBBON BASE CREDENZA ASSEMBLY ..... 2
- CREDENZA TO THE FLOOR ASSEMBLY ..... 6
- TOUCH LATCH ADJUSTMENT ..... 12
- MULTI-PIECE TABLE ASSEMBLY..... 13
- EXPANDABLE BASE ASSEMBLY & ATTACHMENT ..... 14
- CAFÉ TABLE BASE ASSEMBLY & ATTACHMENT..... 17
- GEO BASE ASSEMBLY & ATTACHMENT..... 20
- LEG BASE ASSEMBLY & ATTACHMENT..... 22
- ADJUSTABLE HEIGHT MEDIA TABLE ASSEMBLY..... 24
- MEDIA TABLE WHITE BOARD ASSEMBLY ..... 27
- MITER BASE MEDIA TABLE ASSEMBLY ..... 28
- Y BASE MEDIA TABLE ASSEMBLY ..... 31
- MEDIA WALL MOUNT ATTACHMENT ..... 34
- FULL TAPER BASE ATTACHMENT ..... 35
- HOOP BASE ATTACHMENT..... 36
- Y BASE TABLE WITH BEAM ASSEMBLY & X BASE ..... 38
- TRAINING TABLE BASE AND FLIP INSTRUCTIONS ..... 40
- SUBTOP TAPE TO ROUT ..... 42
- WHITEBOARD ATTACHMENT ..... 43
- OCCASIONAL TABLE ASSEMBLY ..... 44
- PORT ASSEMBLY..... 47
- ALUMINUM PORT DOOR ASSEMBLY ..... 48
- VENEER PORT DOOR ASSEMBLY ..... 49
- ELLORA PORT INSTRUCTIONS ..... 50
- CABLE CUBBY INSTALLATION GUIDE..... 51
- UNO, DUO, TRIO CLAMP MOUNT INSTRUCTIONS ..... 57
- UNO, DUO, TRIO BEZEL MOUNT INSTRUCTIONS..... 58
- UNO, DUO, TRIO UNDER MOUNT INSTRUCTIONS..... 59
- BRIEFING LEG BASE TABLE ASSEMBLY..... 60

# ASSEMBLY INSTRUCTION RIBBON BASE CREDENZA

B2013-0001-00  
REV A  
DATE: 27-SEP-2019

## GENERAL NOTES

1. ALWAYS PROTECT THE CREDENZA DURING INSTALLATION.
2. ALWAYS LEVEL UNIT(S) AT FINAL LOCATION.

## HARDWARE

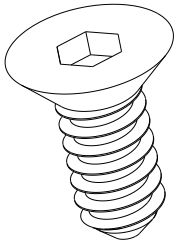

SCR 5/16-18X3/4 FH

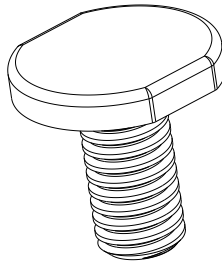

GLIDE 5/16-18 X 5/8 X 3/4

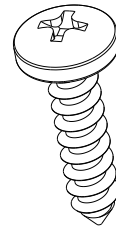

SCR 10X3/4" PN PH

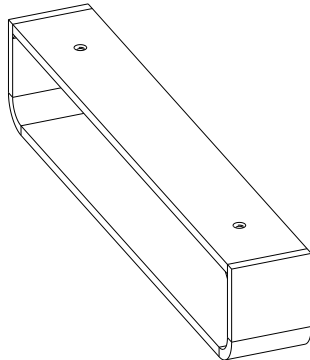

RIBBON BASE FOOT

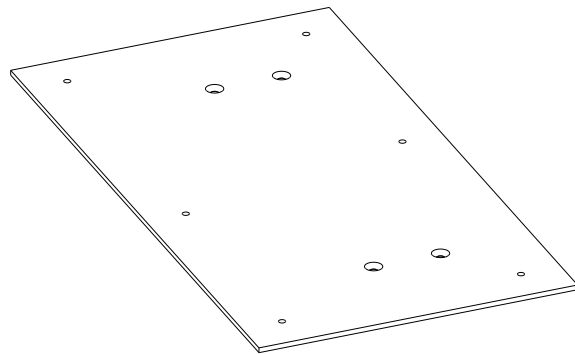

RIBBON BASE PLATE

NOTE: BEFORE ASSEMBLY, DETERMINE THE POSITION OF BASE AND NOTE THE LOCATION OF THE RIBBON BASE FOOT ON THE RIBBON BASE PLATE

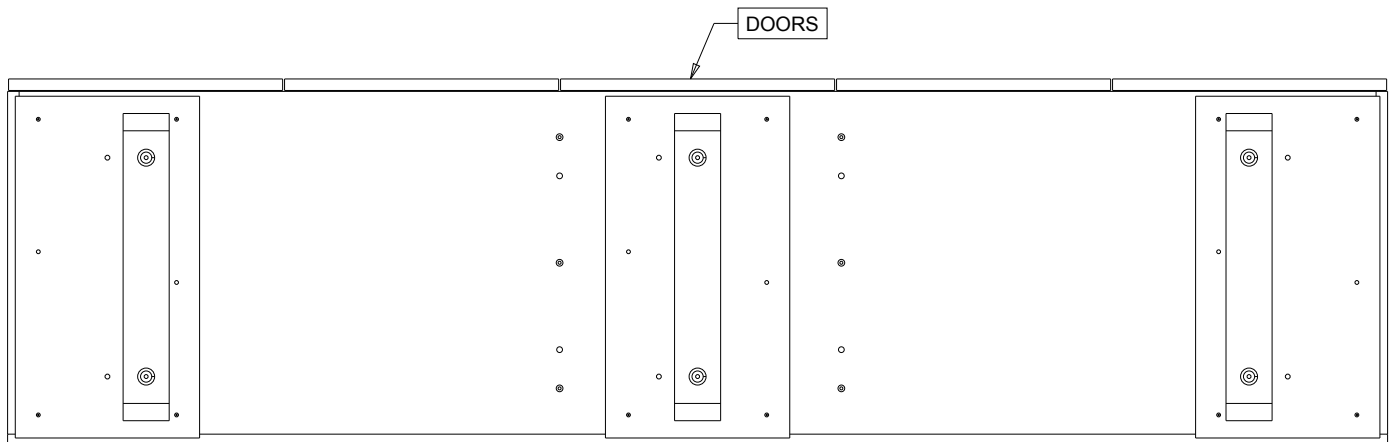

LEFT POSITION

CENTER POSITION

RIGHT POSITION

\*\* CENTER BASE ONLY NEEDED IN 90" AND 108" WIDTH \*\*

LEFT AND RIGHT POSITION  
FOOT LOCATION

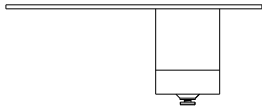

CENTER POSITION  
FOOT LOCATION

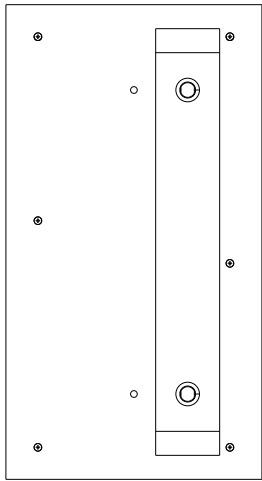
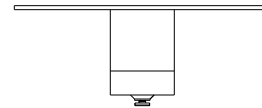

USE SCREW HOLES  
AS A REFERENCE

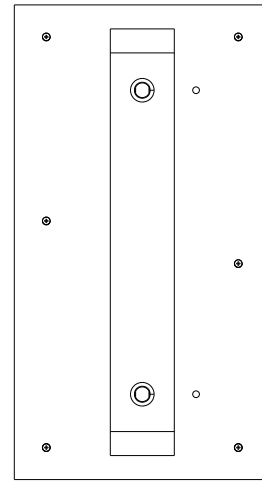

### ASSEMBLY INSTRUCTIONS

- 1 AFTER DETERMINING BASE LOCATION, ATTACH EACH RIBBON BASE PLATE TO THE RIBBON BASE FOOT USING TWO 5/16-18X3/4 FLAT HEAD SCREWS
- 2 THREAD THE 5/16-18 X 5/8 X 3/4 GLIDES INTO THE BOTTOM OF THE BASE FOOT, TWO PER FOOT
- 3 CAREFULLY LAY THE CREDENZA ONTO ITS BACK, PROTECTING UNIT AT ALL TIMES. USING THE 10X3/4" PAN HEAD SCREWS IN THE INTENDED LOCATION. ATTACH THE BASE PLATES TO THE CREDENZAS BOTTOM PANEL USING THE FOUR (PER PLATE) PILOT HOLES PROVIDED. EACH PLATE REQUIRES SIX PAN HEAD SCREWS.
- 4 CAREFULLY FLIP UNIT BACK ONTO RIBBON BASE LEGS, PLACE IN DESIRED LOCATION AND LEVEL UNIT.

1

LEFT AND RIGHT POSITION BASES

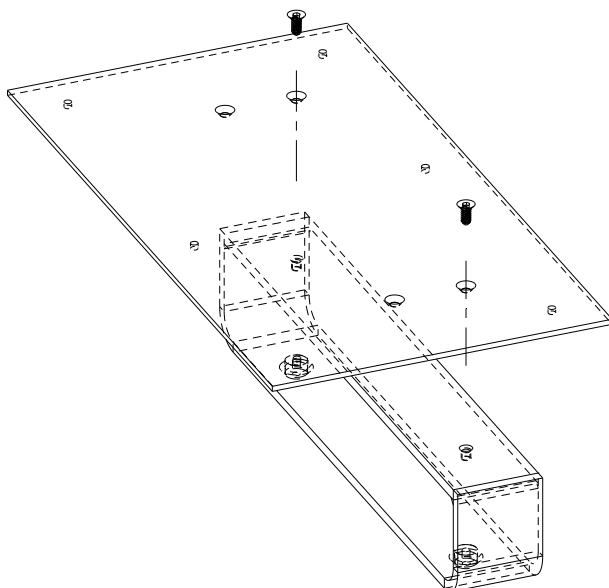

CENTER POSITION BASES

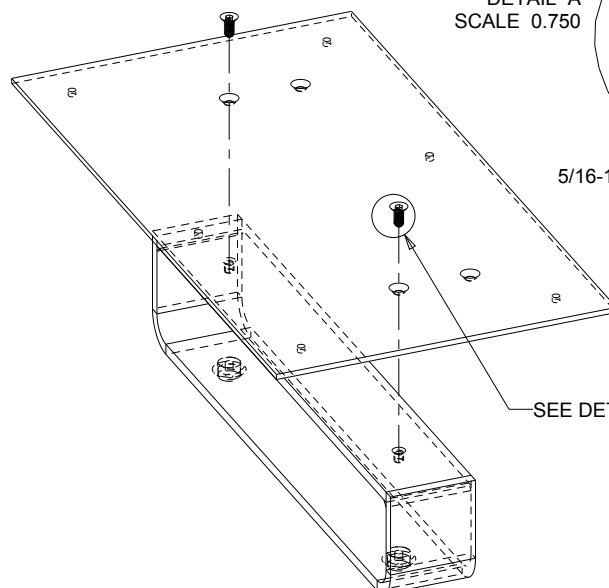

DETAIL A  
SCALE 0.750

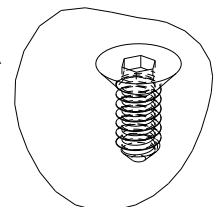

5/16-18X3/4 FLAT HEAD

SEE DETAIL A

2

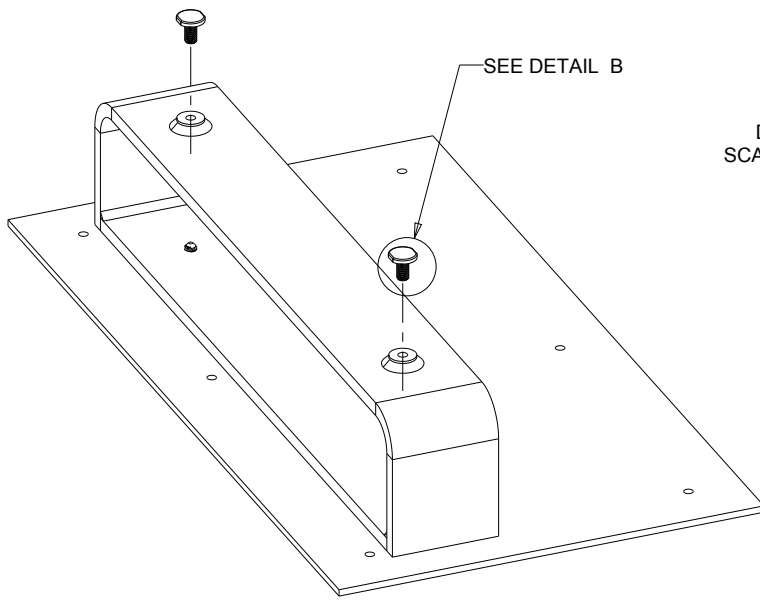

DETAIL B  
SCALE 1.000

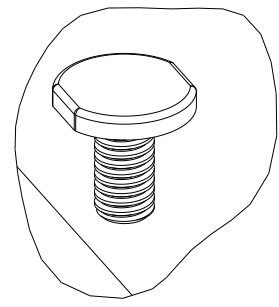

5/16-18 X 5/8 X 3/4 GLIDE  
(2X GLIDES PER FOOT)

3

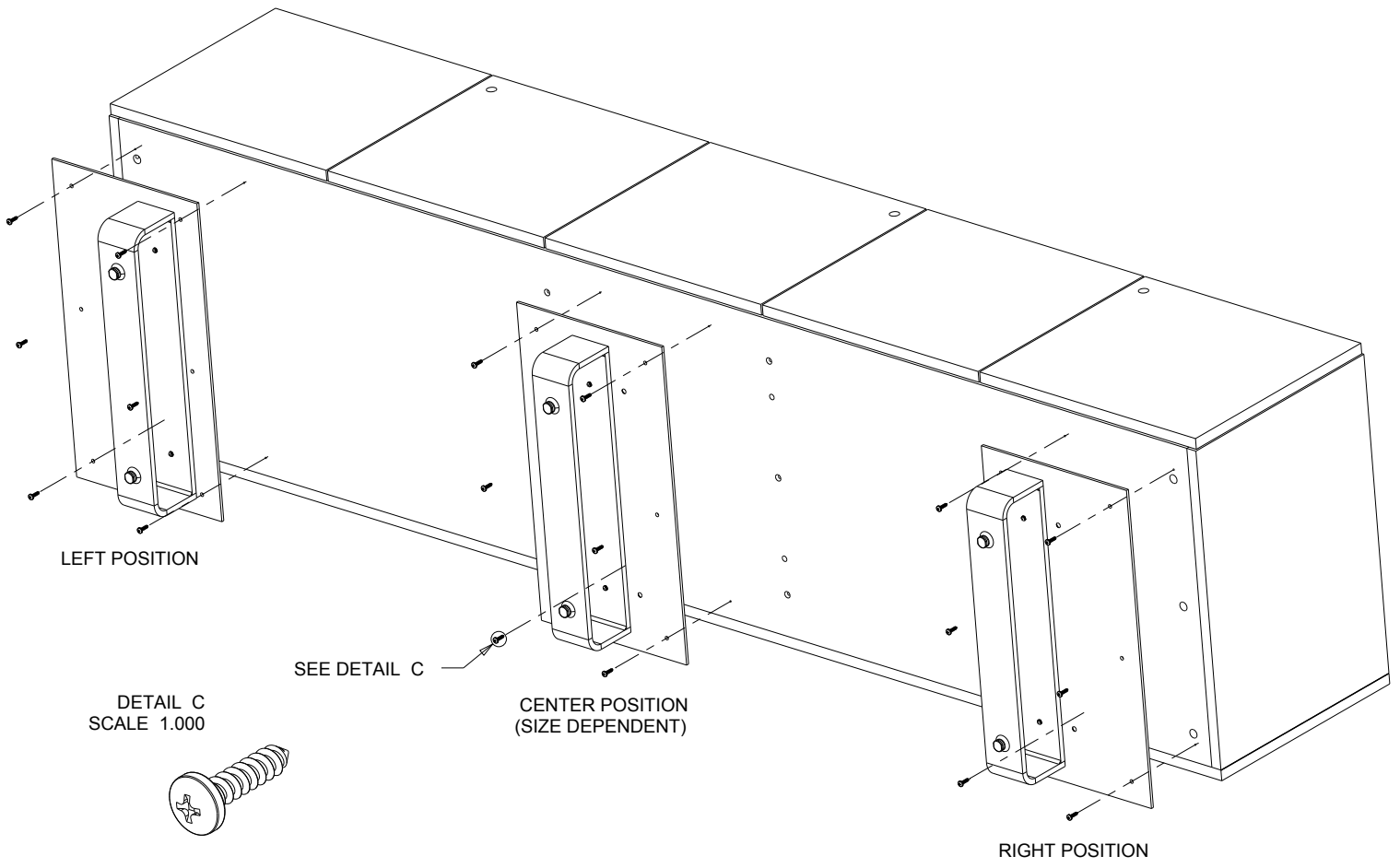

LEFT POSITION

SEE DETAIL C

CENTER POSITION  
(SIZE DEPENDENT)

RIGHT POSITION

DETAIL C  
SCALE 1.000

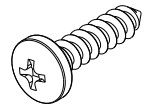

10X3/4" PAN HEAD SCREWS  
(6X PER PLATE)



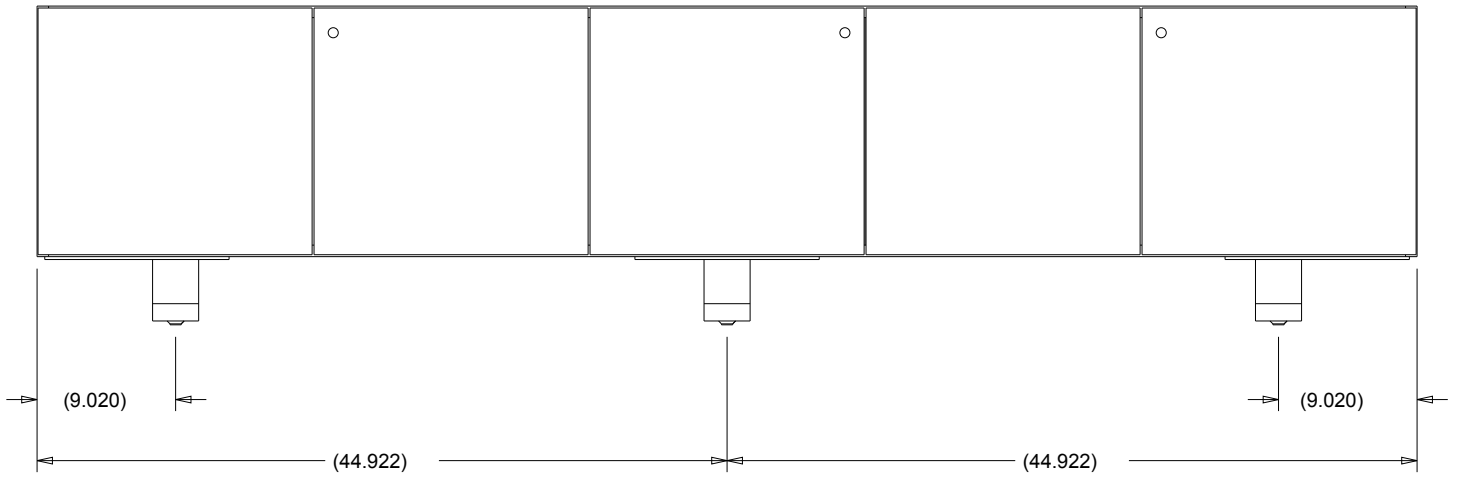
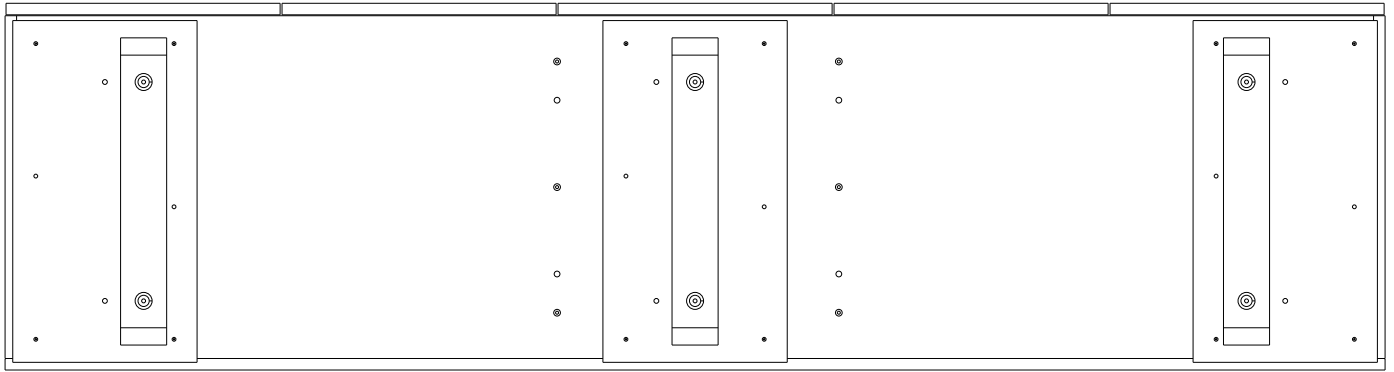

# ASSEMBLY INSTRUCTION CREDENZAS TO THE FLOOR

B2013-0003-00  
REV A  
DATE: 05-NOV-2019

## GENERAL NOTES

1. ALWAYS PROTECT THE CREDENZA DURING INSTALLATION.
2. ALWAYS LEVEL UNIT(S) AT FINAL LOCATION.

## HARDWARE

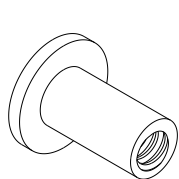

PED GANGING BOLTS

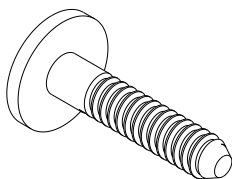

DOWEL

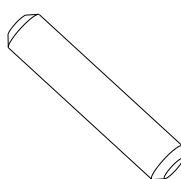

MINI-FIX STUD

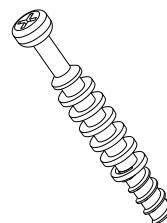

MINI-FIX CAM

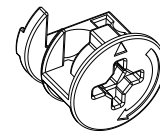

CORNER BRACKET

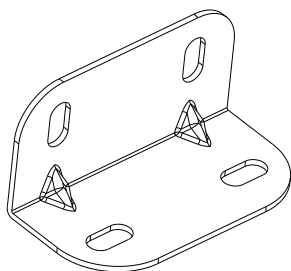

SCREW 1/2" HEX HED

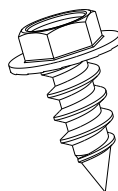

SCREW 3/4" HEX HED

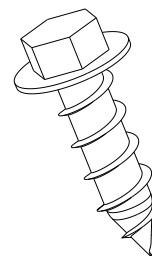

NOTE: 96" WIDE MODEL WITH BACK PANEL YES SHOWN. ASSEMBLY OF ALL OTHER SIZES AND NO BACK PANEL OPTION TO BE SIMILAR.

	PED LOCATIONS (LEFT TO RIGHT)			
48W	GD2C-CBS24A-L	-	-	GD2C-CBS24D-L
72W	GD2C-CBS24A-L	-	GD2C-CBS24C-L	GD2C-CBS24D-L
96W	GD2C-CBS24A-L	GD2C-CBS24B-L	GD2C-CBS24C-L	GD2C-CBS24D-L

NOTE: GD2C-CBS SHOWN, TABLE ALSO TRUE FOR GD2C-CSS MODEL

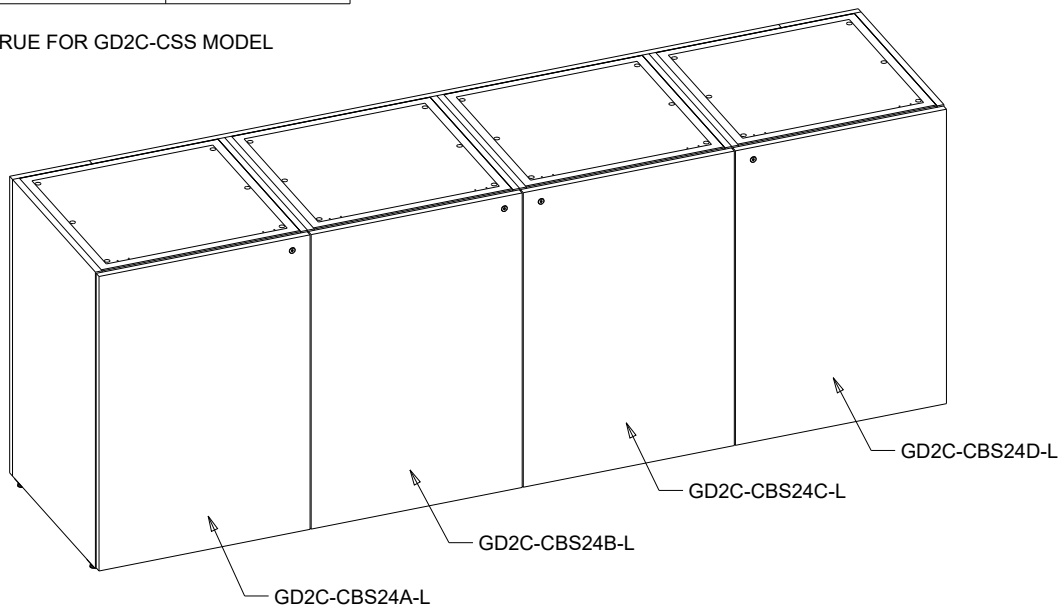

# ASSEMBLY INSTRUCTIONS

1 REMOVE ALL INTERNAL COMPONENTS IN PEDS, THIS IS NEEDED TO ATTACH THE BACK PANEL/FILLER PANEL AND TO GANG PEDS TOGETHER.

SP1 OPTION - ADJUSTABLE SHELF AND INSET BACK PANEL

SP4 OPTION - ADJUSTABLE SHELF, INSET BACK PANEL, AND FOUR DRAWERS

SPU OPTION - NOTHING, UNIT DOES NOT HAVE ANY INTERNAL COMPONENTS

2 USING THE PED LOCATION TABLE ON SHEET 1, PLACE EACH PED IN ORDER NEXT TO EACH OTHER FLUSHING THE FRONTS.

3 GANG EACH PAIR OF PEDS TOGETHER WITH FOUR GANGING BOLT SETS AND ALLEN WRENCHS USING THE THROUGH HOLES PROVIDED IN THE KNEEWELL PANELS. MAKE SURE THE FRONT AND TOP OF THE UNITS ARE FLUSH WHITH EACH OTHER AFTER GANGING.

4 SCREW THE CORNER BRACKETS TO THE KNEEWELL PANELS USING THE 3/4" HEX HEAD SCREWS AND THE PILOT HOLES PROVIDED.

5 PLACE THREE MINI-FIX CAMS (SIX TOTAL) IN THE BACK CAM HOLES IN EACH END PANEL.

6 ATTACH THE MINI-FIX STUDS AND DOWELS IN THE BACK PANEL.

NOTE: IF BACK NO OPTION IS ORDERED, PART IS UNIVERSAL AND CAN BE USED ON BOTH LEFT/RIGHT END PANELS.

7 ALIGN THE BACK PANEL MINI-FIX STUDS AND DOWELS UP WITH THE HOLES IN EACH END PANEL. USING A PHILLIPS HEAD SCREW DRIVER, TIGHTEN THE MINI-FIX CAMS ON THE INSIDE OF THE END PANELS MAKING SURE PANELS ARE FLUSH.

8 SECURE THE BACK PANEL WITH THE CORNER BRACKET BY USING THE 1/2" HEX HEAD SCREWS.

9 INSERT ALL INTERNAL COMPONENTS THAT WERE REMOVED DURING INSTALLATION PROCESS. PLACE INTO DESIRED LOCATION AND LEVEL THE UNIT.

1

SP1 OPTION (DOORS OMITTED)

REMOVE BACK INSET BACK

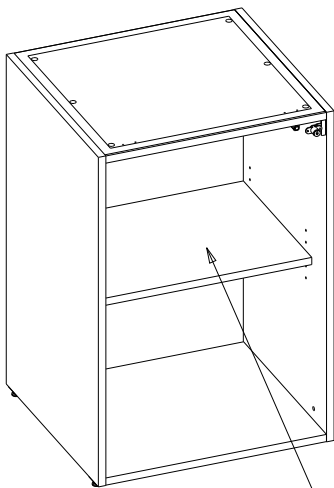

REMOVE ADJ. SHELF

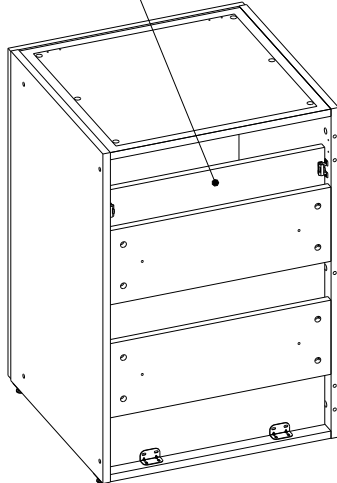

REMOVE INSET BACK

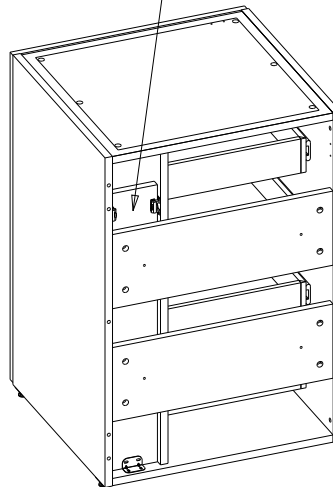

REMOVE ALL FOUR DRAWERS

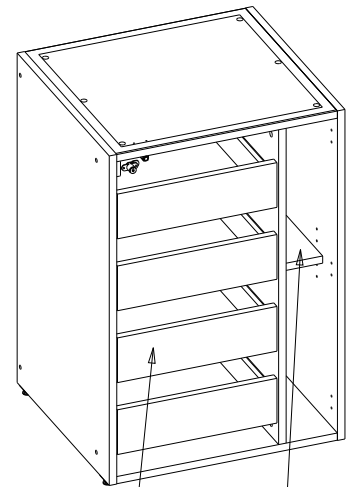

REMOVE ADJ. SHELF

SP4 OPTION (DOORS OMITTED)

2

PLACE PEDS IS NEEDED LOCATIONS, FLUSHING THE FRONT AND TOPS OF THE UNIT

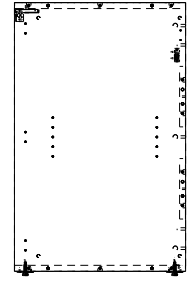
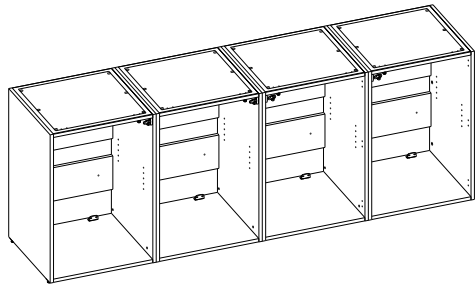

3

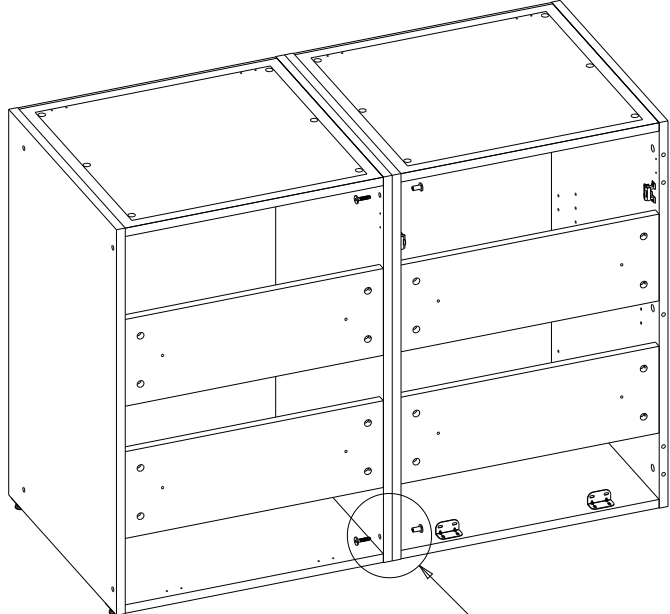
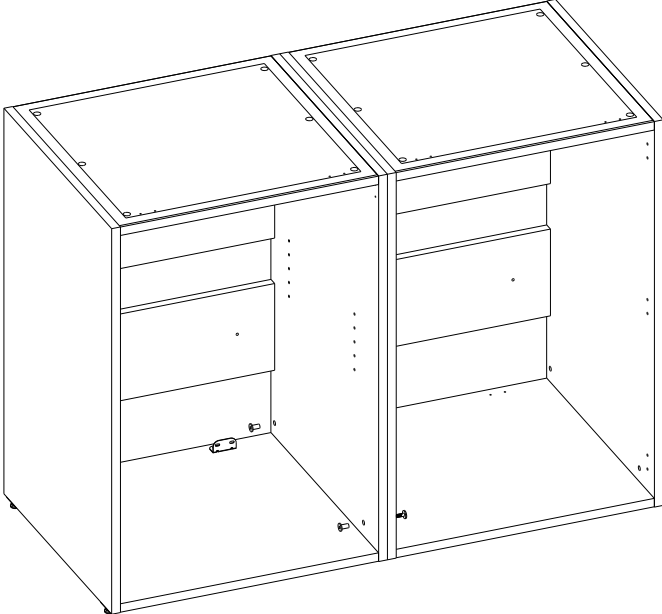

SEE DETAIL A

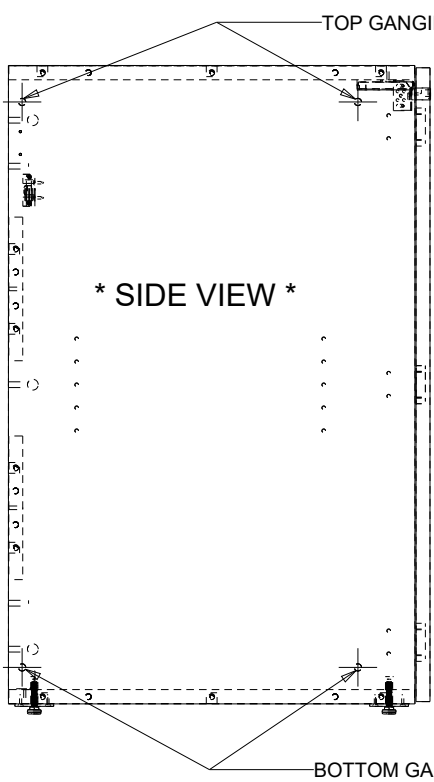

TOP GANGING HOLE LOCATIONS

BOTTOM GANGING HOLE LOCATIONS

DETAIL A  
SCALE 0.650

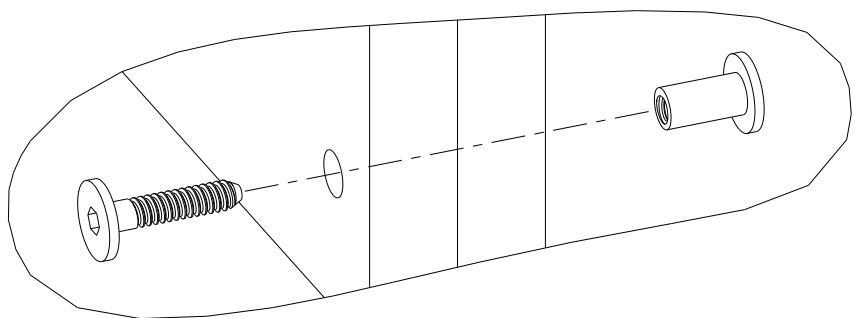

GANG KNEEWELL PANELS TOGETHER, A QUANTITY OF 4 TIMES PER EACH PAIR OF PEDS

4

SEE DETAIL B

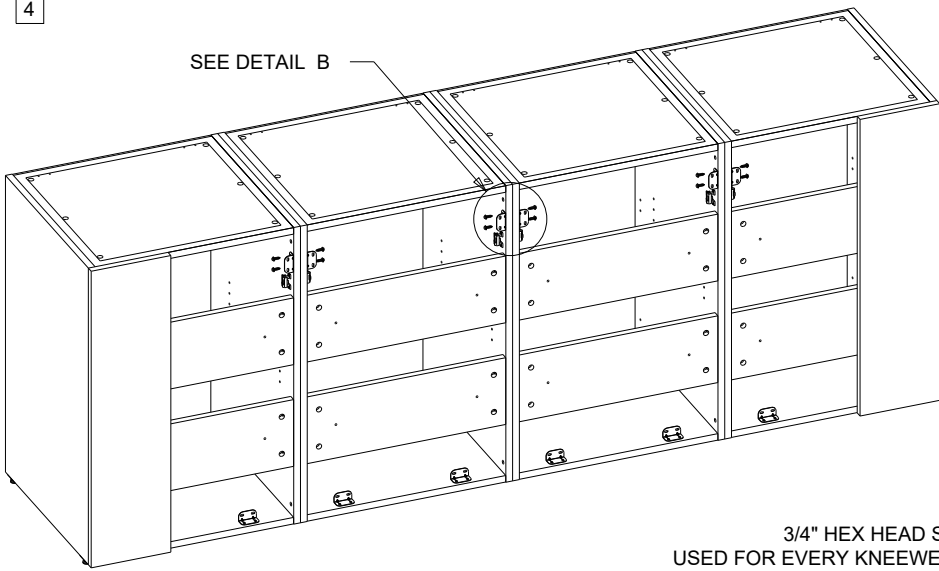

DETAIL B  
SCALE 0.400

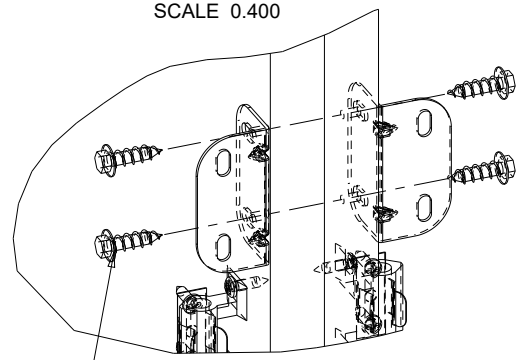

3/4" HEX HEAD SCREWS  
USED FOR EVERY KNEEWELL PANEL

5

SEE DETAIL C

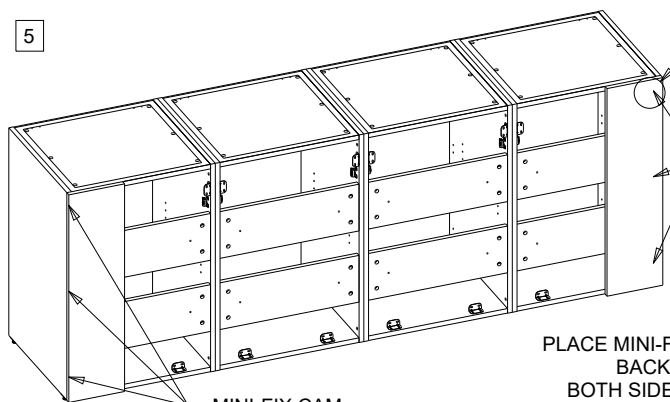

MINI-FIX CAM  
LOCATIONS

MINI-FIX CAM  
LOCATIONS

PLACE MINI-FIX CAMS INTO THE INSIDE  
BACK HOLES OF THE END PANELS,  
BOTH SIDES, 3 HOLES PER END PANEL

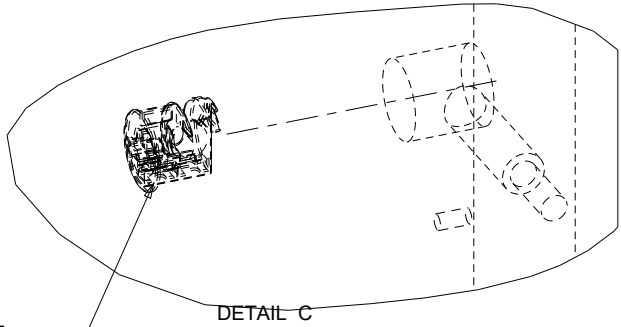

DETAIL C  
SCALE 0.750

6

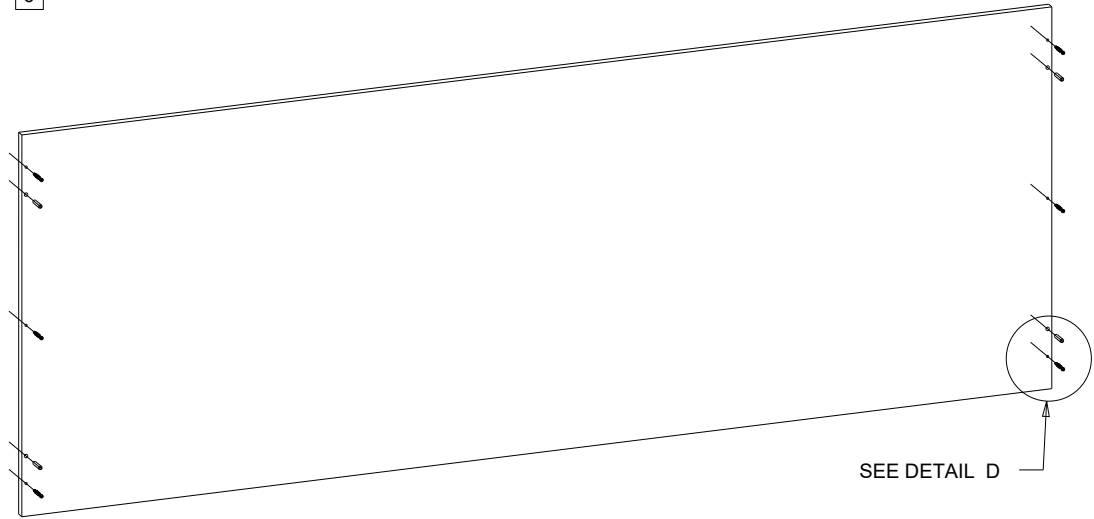

SCALE 0.060

SEE DETAIL D

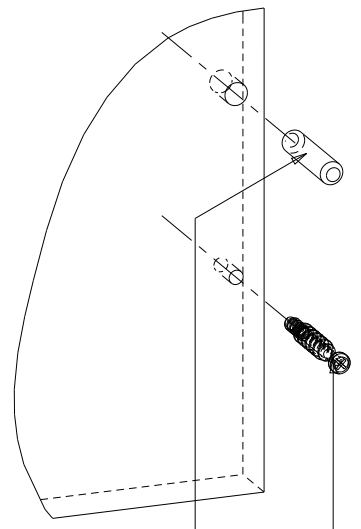

DETAIL D  
SCALE 0.400

DOWEL

MINI-FIX STUDS

7

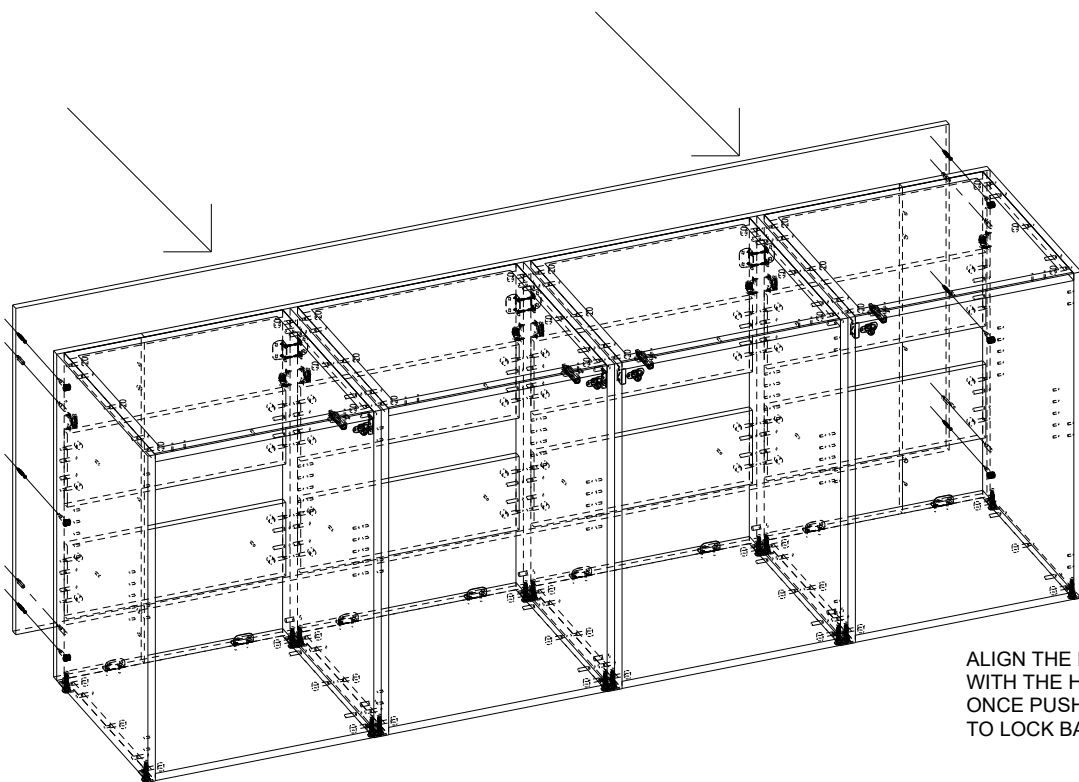

ALIGN THE DOWELS/MINI-FIX STUDS WITH THE HOLES IN THE END PANEL. ONCE PUSHED IN, TIGHTEN THE CAMS TO LOCK BACK PANEL IN PLACE

8

SEE DETAIL E

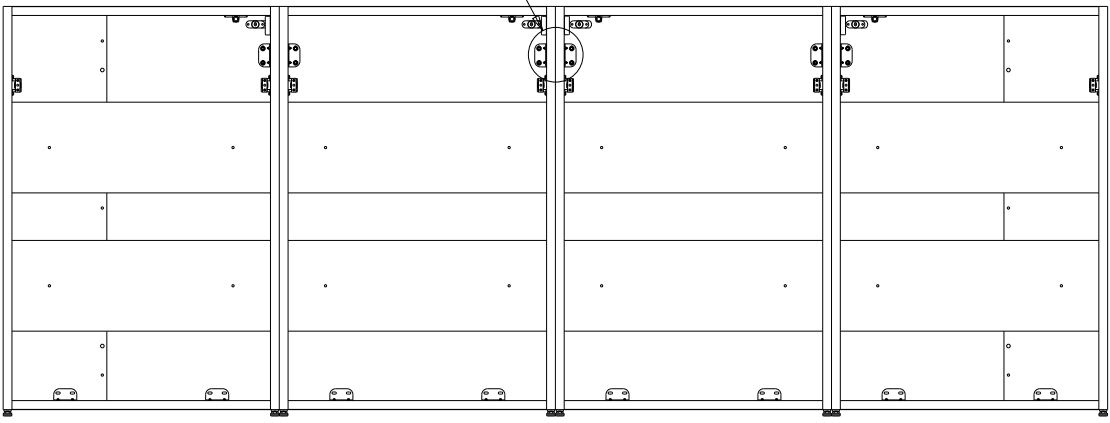

DETAIL E  
SCALE 0.500

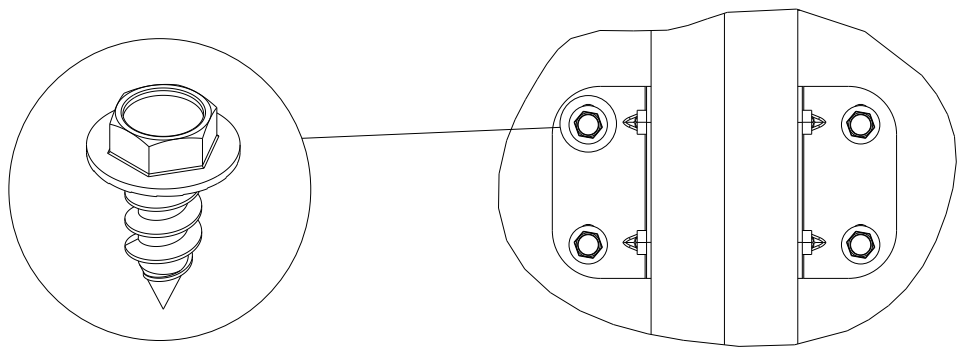

USING THE 1/2" HEX HEAD SCREWS, SCREW THE BACK PANEL TO THE CORNER BRACKETS

SP1 OPTION (DOORS OMITTED)

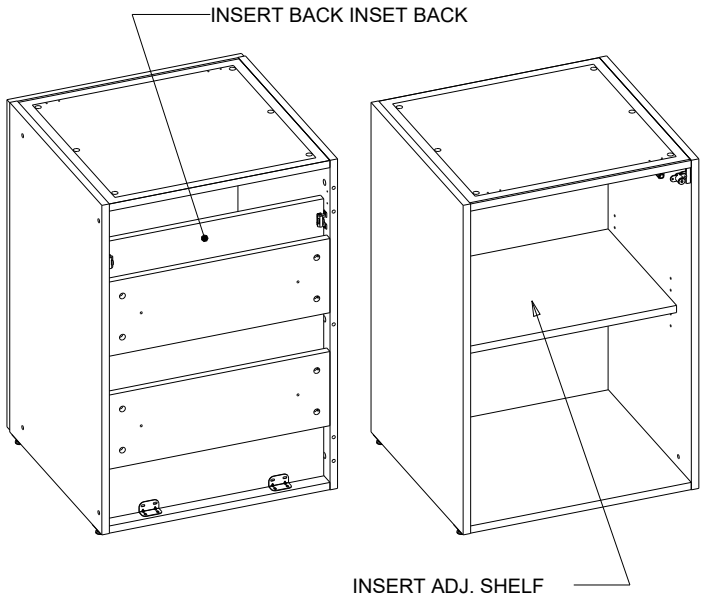

PLACE ALL COMPONENTS THAT WERE REMOVED  
BACK IN TO ITS ORIGINAL LOCATION

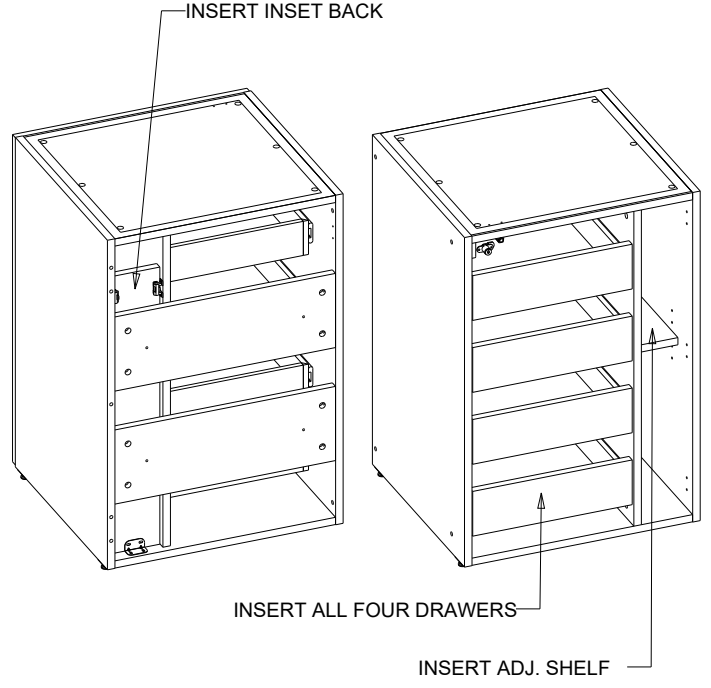

SP4 OPTION (DOORS OMITTED)

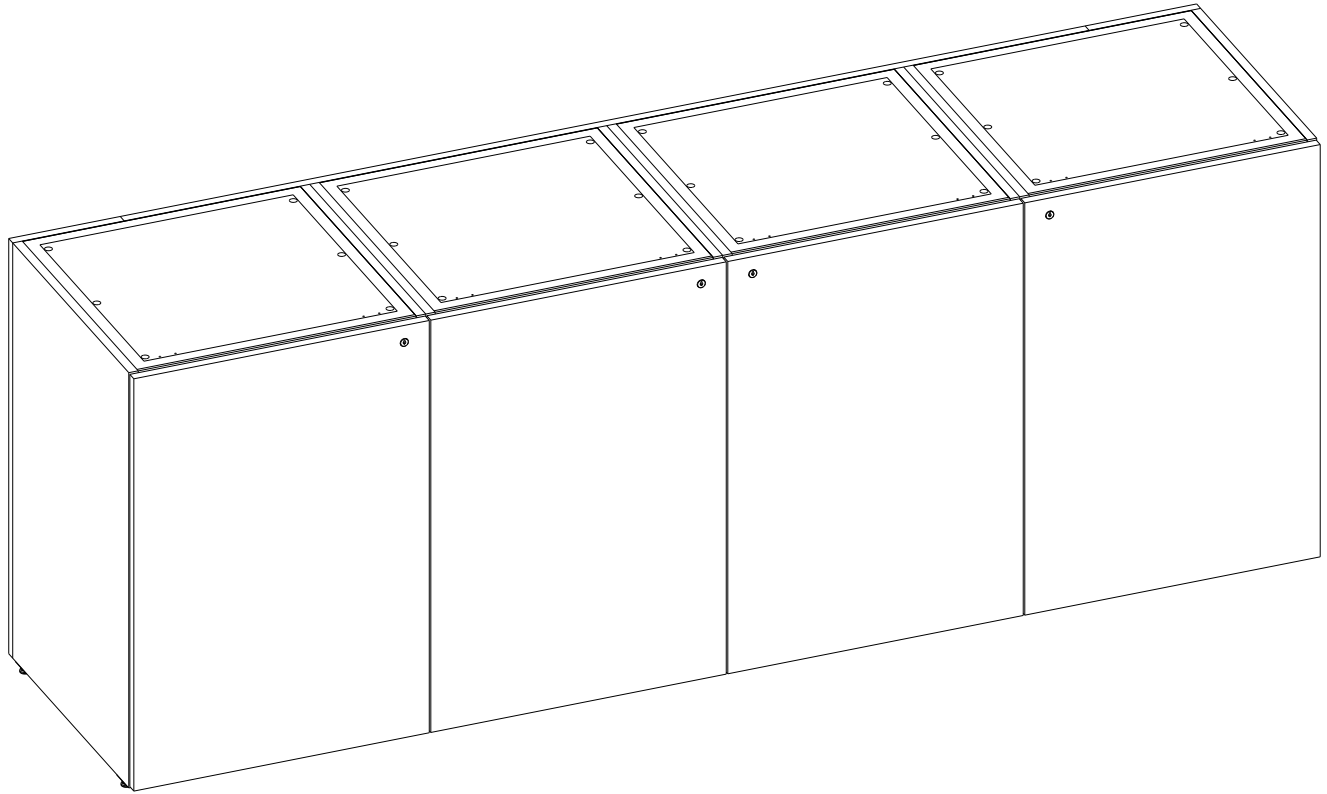

## GENERAL NOTES

1. DOOR ADJUSTMENTS FOR ALL BRIEFING TOUCH LATCHES

## ATTACHMENT HARDWARE

1. NONE

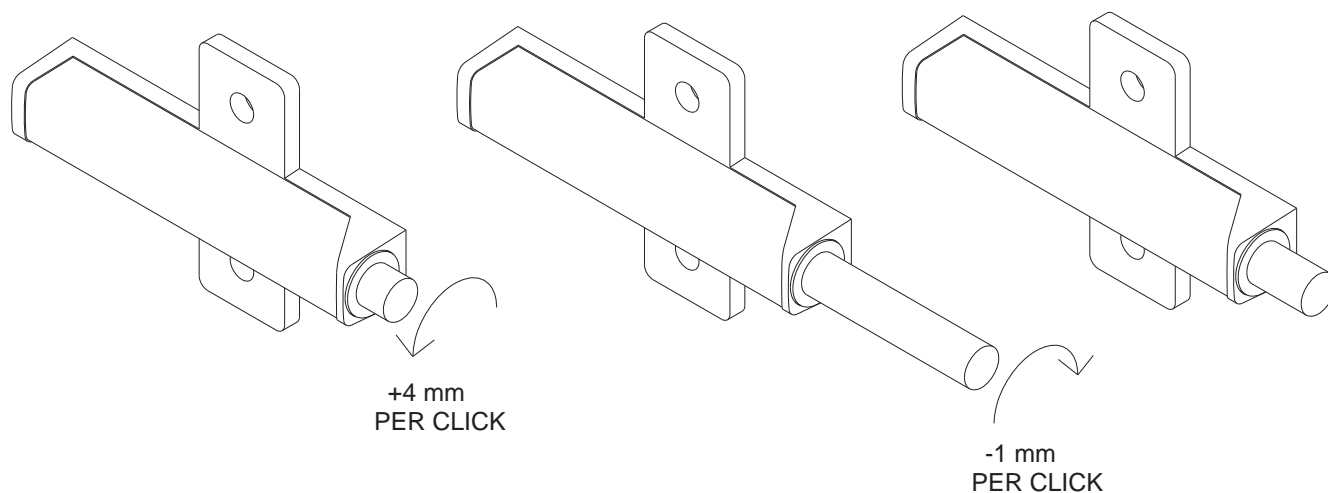
**1** TOUCH LATCH DOOR ADJUSTMENT

## ADJUSTMENT:

1. IF THE DOOR IS INSET OF THE DOOR BESIDE IT, ROTATE THE INSERT COUNTER CLOCKWISE UNTIL FLUSH
2. IF THE DOOR IS OUTSET OF THE DOOR BESIDE IT, ROTATE THE INSERT CLOCKWISE UNTIL FLUSH.



## GENERAL NOTES

1. ASSEMBLY REQUIRES TWO PEOPLE.
2. ALWAYS PROTECT THE WORKSURFACE DURING INSTALLATION.
3. ALWAYS ASSEMBLE UNIT(S) AT FINAL LOCATION.

## HARDWARE

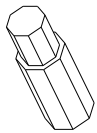

19890-0024-31  
5mm DRIVER BIT

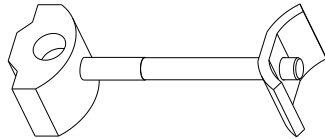

19928-0092-24  
ZIPBOLT

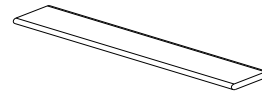

1907-7160-24  
SPLINE

## WARNING

ALWAYS INSTALL THE TOPS IN THE RIGHT-SIDE UP POSITION ON THE BASE BEFORE ASSEMBLY.

DO NOT LOCK THE DRIVER'S SLIP CLUTCH

DO NOT OVERTIGHTEN ZIPBOLTS

DO NOT LIFT THE TOP ONCE ZIPBOLTS ARE INSTALLED. THIS WILL PINCH THE VENEER AND CLEAR COAT CAUSING DAMAGE AT THE SEAM.

ASSEMBLY IS CRITICAL. FAILURE TO FOLLOW INSTRUCTIONS MAY RESULT IN DAMAGE TO TABLE TOP, EDGES, SEAM AND OR FINISH. MANUFACTURER IS NOT RESPONSIBLE FOR DAMAGES AS A RESULT OF NOT FOLLOWING THESE ASSEMBLY INSTRUCTIONS.

## ASSEMBLY

- 1 INSTALL SPLINES IN ONE SIDE OF THE TABLE TOP
- 2 SET UP BASES IN FINAL LOCATION. SEE BASE ASSEMBLY INSTRUCTIONS. PLACE THE TOPS ON ON THE BASES.
- 3 USE TWO PEOPLE TO ALIGN SPLINES IN ONE TOP TO GROOVE IN AJOINING TOP.USE CARE AND SLIDE THE TOPS TOGETHER.
- 4 SET DRIVER AT LOWEST SETTING TO START ZIPBOLT ASSEMBLY. USE ONE PERSON TO KEEP TOPS AND EDGES ALIGNED AND ONE PERSON TO START INSTALLING ZIPBOLTS.
- 5 ONCE THE ZIPBOLTS ARE IN PLACE SET THE DRIVER TO MAXIMUM SETTING AND RETIGHTEN ALL ZIPBOLTS.
- 6 CAREFULLY CENTER TOPS ON BASES, ATTACH TOPS TO BASES WITH SUPPLIED SCREWS. (SEE BASE ASSEMBLY INSTRUCTIONS)
- 7 PLACE LEVEL ON TABLE AND LEVEL ASSEMBLY USING ADJUSTABLE GLIDES (IF NEEDED). SEE LEVELING INSTRUCTIONS.

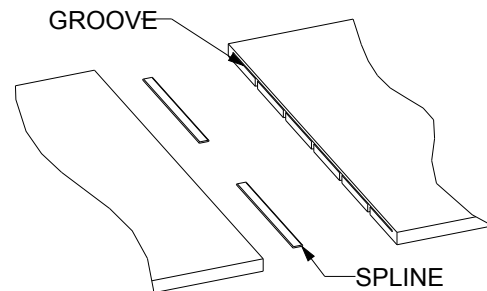

Spline - Location varies by Product

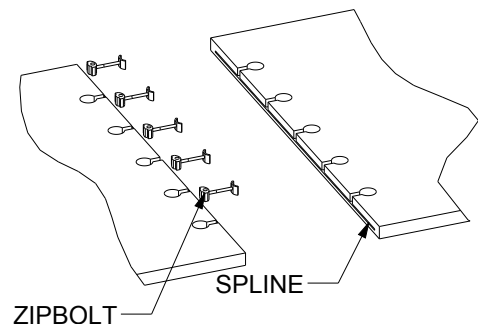

BOTTOM VIEW  
Multi-Piece Table Top Assembly

## GUNLOCKE

## GENERAL NOTES

1. ALWAYS PROTECT THE WORKSURFACE DURING INSTALLATION.
2. ALWAYS LEVEL UNITS(S) AT FINAL LOCATION.

## ATTACHMENT HARDWARE



14-20X3/4 SERRATED HEX  
FLANGED WASHER



#10X3/4 PAN HEAD  
WOOD SCREW

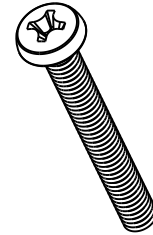

1/4-20X2 PAN HEAD BOLT

- 1 ATTACH BASE BRACKETS TO THE TUBE WITHIN THE BASES  
USING 1/4-20X2" PAN HEAD BOLT
- 2 STAND EXPANDABLE BASE IN UPRIGHT POSITION
- 3 ATTACH EXPANDABLE BASE BRACKETS TO BEAMS  
USING 1/4-20X3/4" SERRATED HEX FLANGED WASHERS
- 4 CENTER CONFERENCE TOP (LENGTH & WIDTH)  
ON BASE ASSEMBLY
- 5 ATTACH BEAMS TO CONFERENCE TOP  
USING 10X3/4" PAN HEAD WOOD SCREWS

DETAIL B  
SCALE 0.200

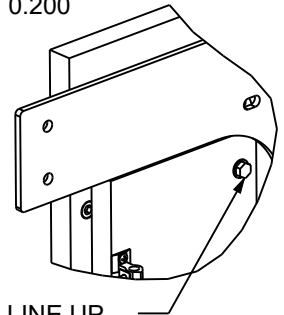

TO ADJUST BASE SIZE: REMOVE BOLTS AND LINE UP  
HOLE WITH INSERT OF DESIRED NEW SIZE. THEN  
TIGHTEN BOLT INTO NEW INSERT ON BOTH SIDES  
AND RE-ATTACH REMOVABLE PANEL

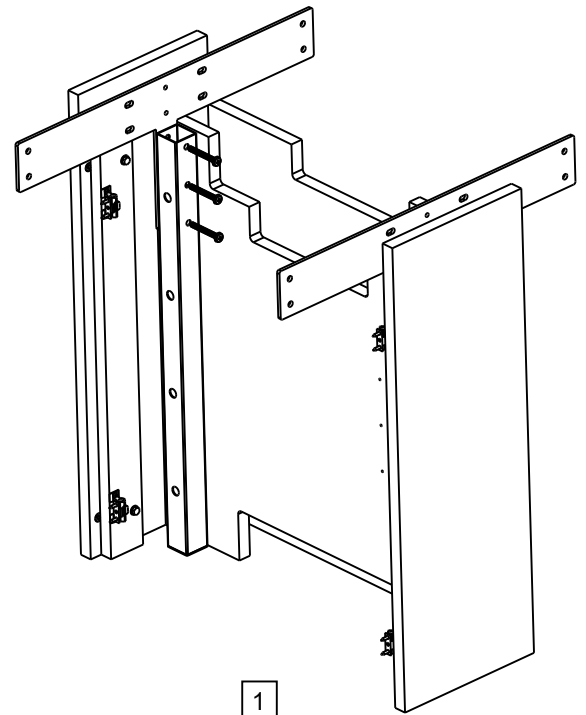
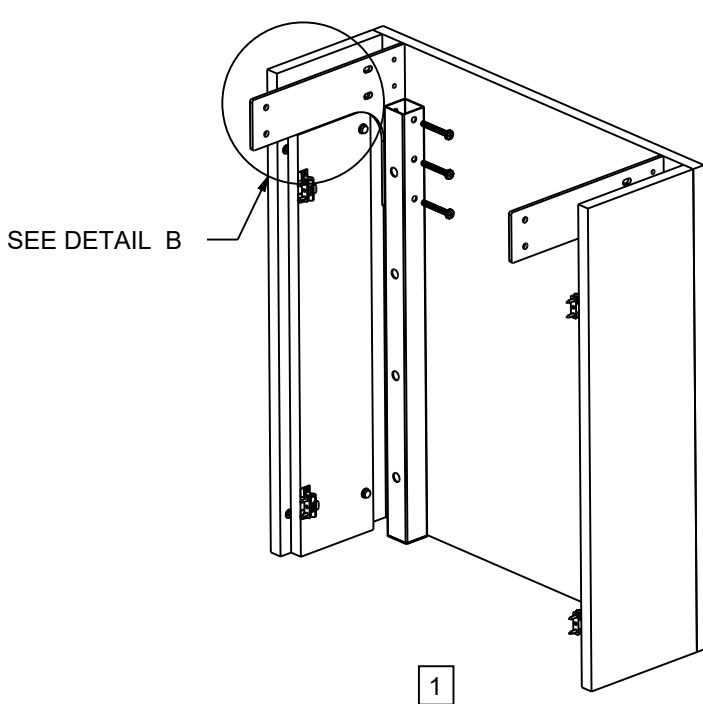

# GUNLOCKE

## GENERAL NOTES

1. ALWAYS PROTECT THE WORKSURFACE DURING INSTALLATION.
2. ALWAYS LEVEL UNITS(S) AT FINAL LOCATION.

1 ATTACH BASE BRACKETS TO THE TUBE WITHIN THE BASES  
USING 1/4-20X2" PAN HEAD BOLT

2 STAND EXPANDABLE BASE IN UPRIGHT POSITION

3 ATTACH EXPANDABLE BASE BRACKETS TO BEAMS  
USING 1/4-20X3/4" SERRATED HEX FLANGED WASHERS

4 CENTER CONFERENCE TOP (LENGTH & WIDTH)  
ON BASE ASSEMBLY

5 ATTACH BEAMS TO CONFERENCE TOP  
USING 10X3/4" PAN HEAD WOOD SCREWS

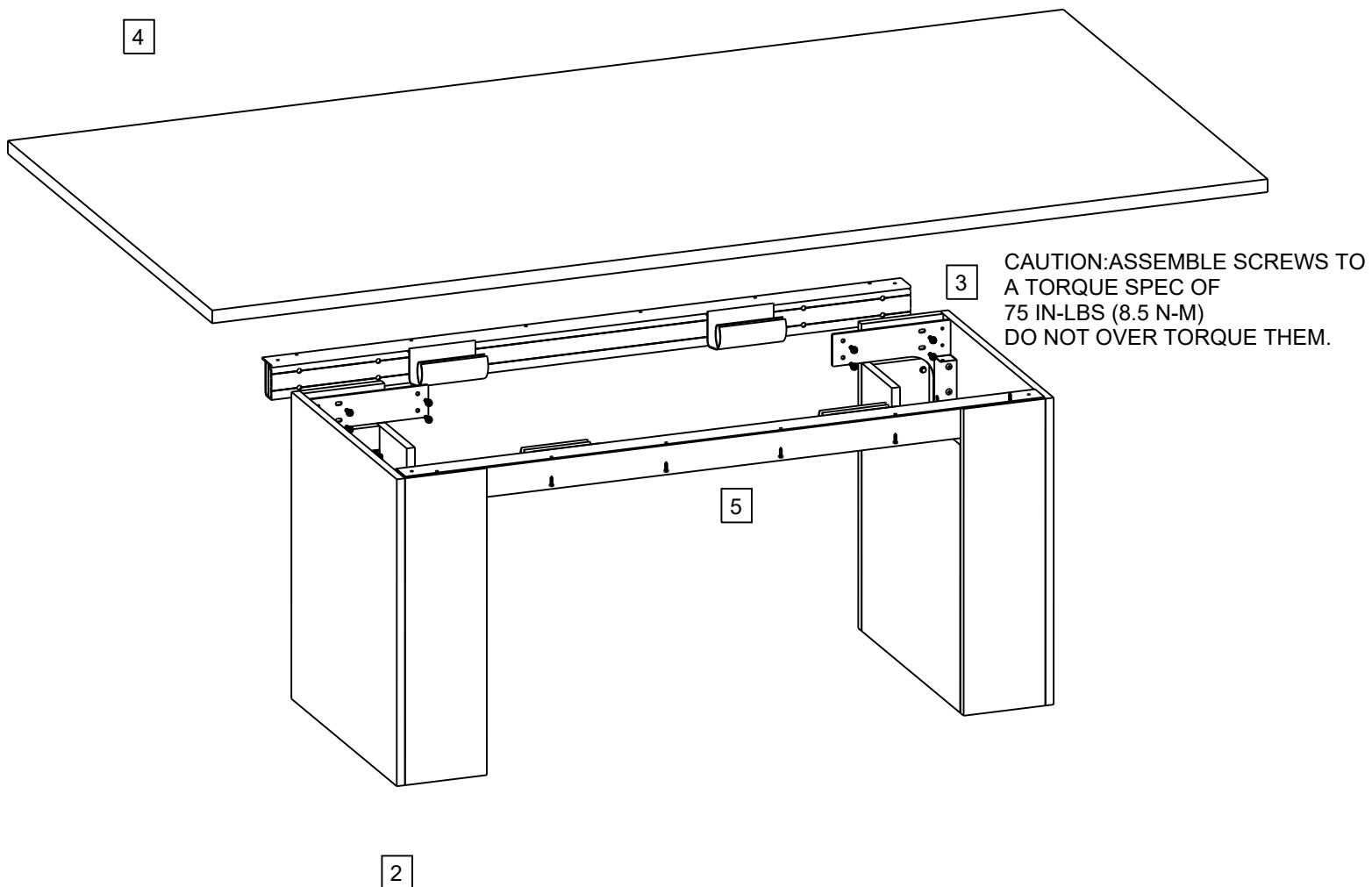

## GUNLOCKE

## GENERAL NOTES

1. ALWAYS PROTECT THE WORKSURFACE DURING INSTALLATION.
2. ALWAYS LEVEL UNITS(S) AT FINAL LOCATION.

1 ATTACH BASE BRACKETS TO THE TUBE WITHIN THE BASES  
USING 1/4-20X2" PAN HEAD BOLT

2 STAND EXPANDABLE BASE IN UPRIGHT POSITION

3 ATTACH EXPANDABLE BASE BRACKETS TO BEAMS  
USING 1/4-20X3/4" SERRATED HEX FLANGED WASHERS

4 CENTER CONFERENCE TOP (LENGTH & WIDTH)  
ON BASE ASSEMBLY

5 ATTACH BEAMS TO CONFERENCE TOP  
USING 10X3/4" PAN HEAD WOOD SCREWS

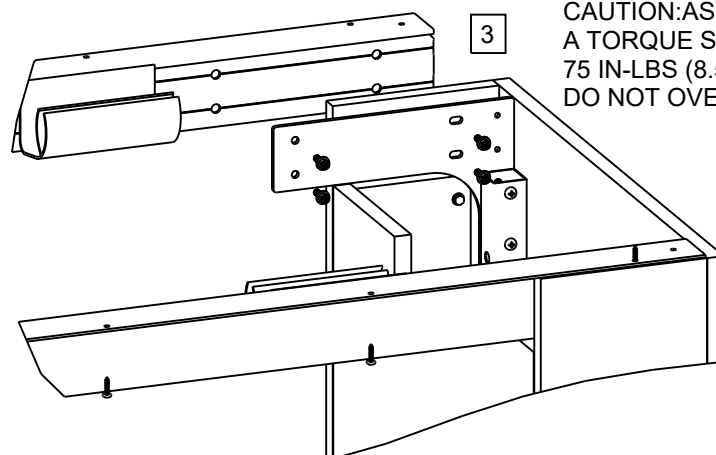
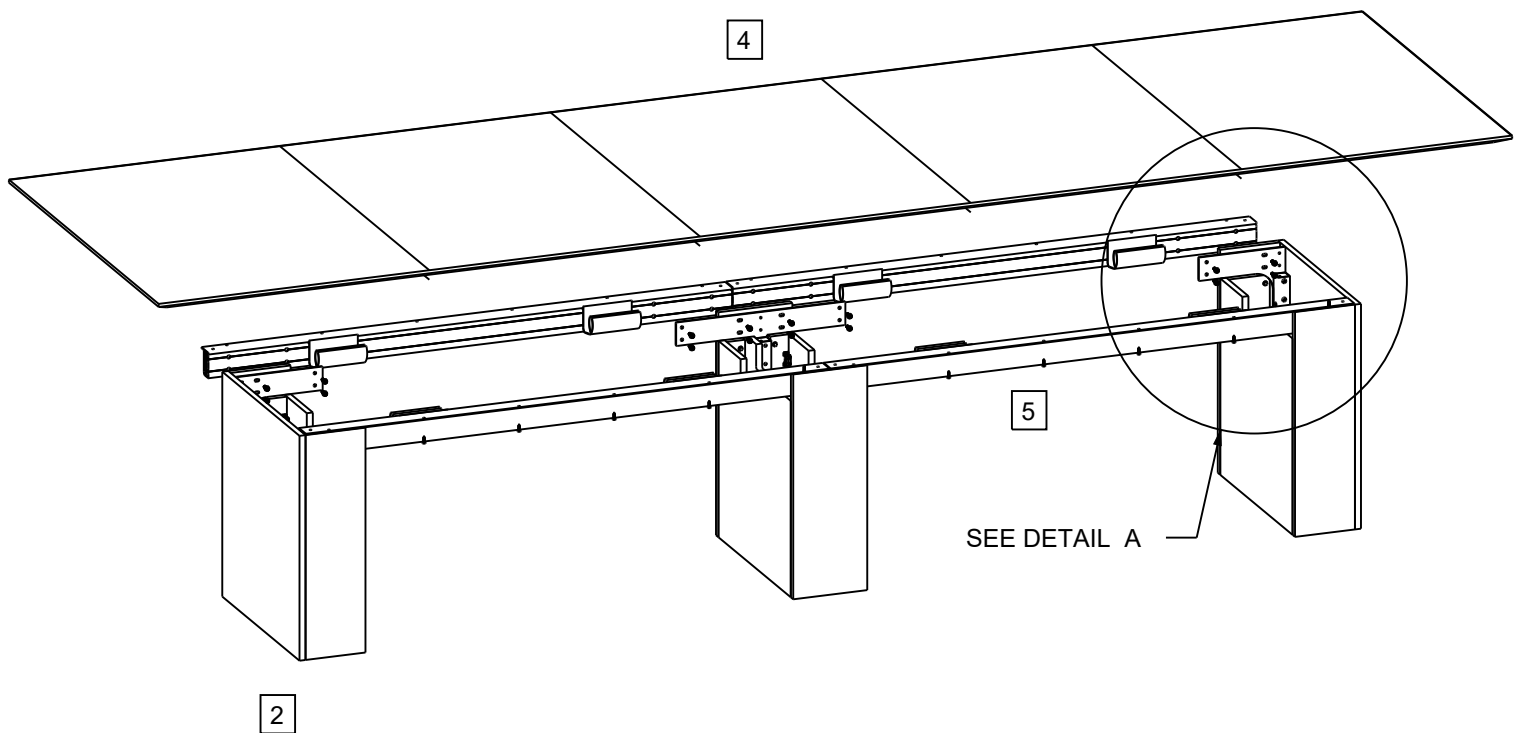

CAUTION: ASSEMBLE SCREWS TO  
A TORQUE SPEC OF  
75 IN-LBS (8.5 N-M)  
DO NOT OVER TORQUE THEM.

### GUNLOCKE

## GENERAL NOTES

1. ALWAYS PROTECT THE WORKSURFACE DURING INSTALLATION.
2. ALWAYS LEVEL UNITS(S) AT FINAL LOCATION.

## ATTACHMENT HARDWARE



14-20X3/4 SERRATED HEX  
FLANGED WASHER



#10X3/4 PAN HEAD  
WOOD SCREW

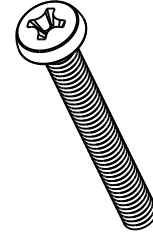

1/4-20X2 PAN HEAD BOLT

- 1 ATTACH BASE BRACKETS TO THE TUBE WITHIN THE BASES  
USING 1/4-20X2" PAN HEAD BOLT
- 2 STAND CAFE TABLE BASE IN UPRIGHT POSITION
- 3 ATTACH CAFE TABLE BASE BRACKETS TO BEAMS  
USING 1/4-20X3/4" SERRATED HEX FLANGED WASHERS
- 4 CENTER CONFERENCE TOP (LENGTH & WIDTH)  
ON BASE ASSEMBLY
- 5 ATTACH BEAMS TO CONFERENCE TOP  
USING 10X3/4" PAN HEAD WOOD SCREWS

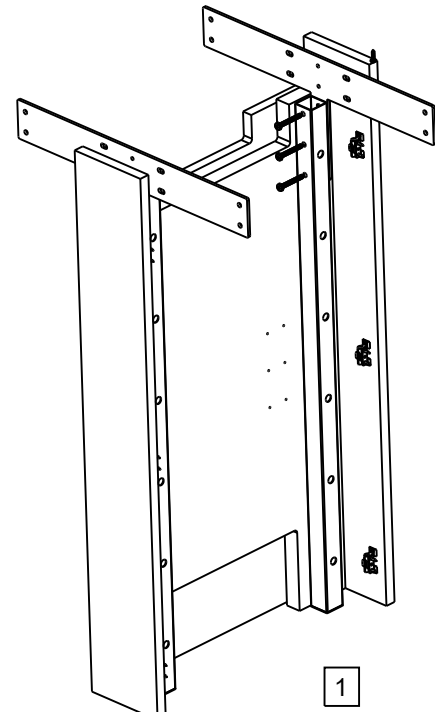
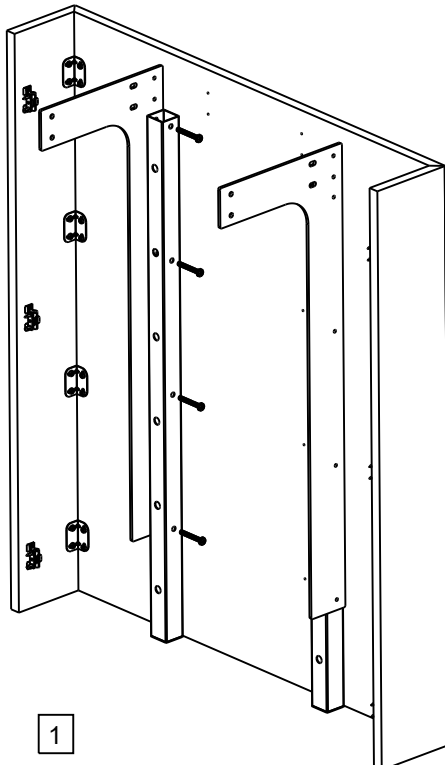

# GUNLOCKE

## GENERAL NOTES

1. ALWAYS PROTECT THE WORKSURFACE DURING INSTALLATION.
2. ALWAYS LEVEL UNITS(S) AT FINAL LOCATION.

- 1 ATTACH BASE BRACKETS TO THE TUBE WITHIN THE BASES  
USING 1/4-20X2" PAN HEAD BOLT
- 2 STAND CAFE TABLE BASE IN UPRIGHT POSITION
- 3 ATTACH CAFE TABLE BASE BRACKETS TO BEAMS  
USING 1/4-20X3/4" SERRATED HEX FLANGED WASHERS
- 4 CENTER CONFERENCE TOP (LENGTH & WIDTH)  
ON BASE ASSEMBLY
- 5 ATTACH BEAMS TO CONFERENCE TOP  
USING 10X3/4" PAN HEAD WOOD SCREWS

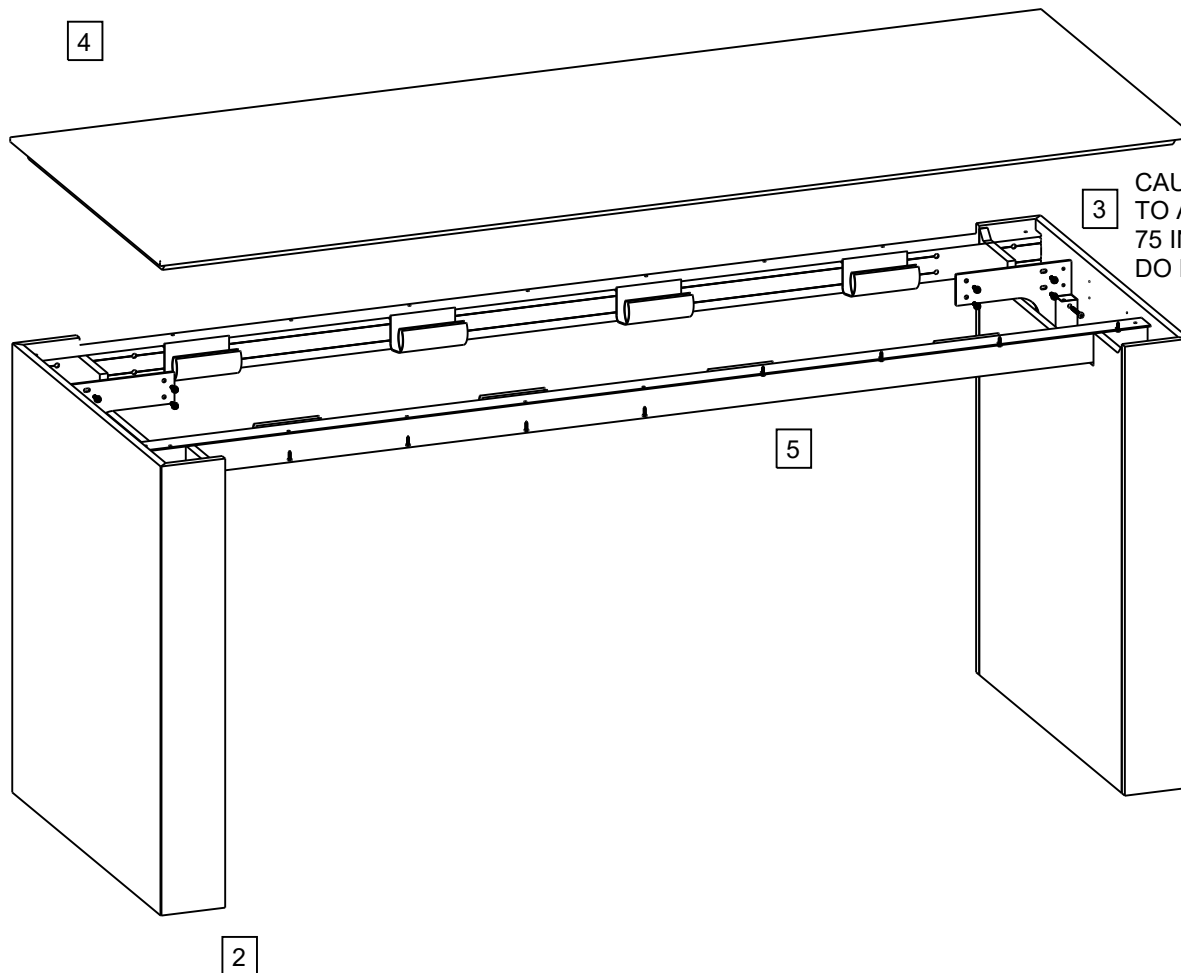

CAUTION: ASSEMBLE SCREWS  
TO A TORQUE SPEC OF  
75 IN-LBS (8.5 N-M)  
DO NOT OVER TORQUE THEM.

### GUNLOCKE

## GENERAL NOTES

1. ALWAYS PROTECT THE WORKSURFACE DURING INSTALLATION.
2. ALWAYS LEVEL UNITS(S) AT FINAL LOCATION.

1 ATTACH BASE BRACKETS TO THE TUBE WITHIN THE BASES  
USING 1/4-20X2" PAN HEAD BOLT

2 STAND CAFE TABLE BASE IN UPRIGHT POSITION

3 ATTACH CAFE TABLE BASE BRACKETS TO BEAMS  
USING 1/4-20X3/4" SERRATED HEX FLANGED WASHERS

4 CENTER CONFERENCE TOP (LENGTH & WIDTH)  
ON BASE ASSEMBLY

5 ATTACH BEAMS TO CONFERENCE TOP  
USING 10X3/4" PAN HEAD WOOD SCREWS

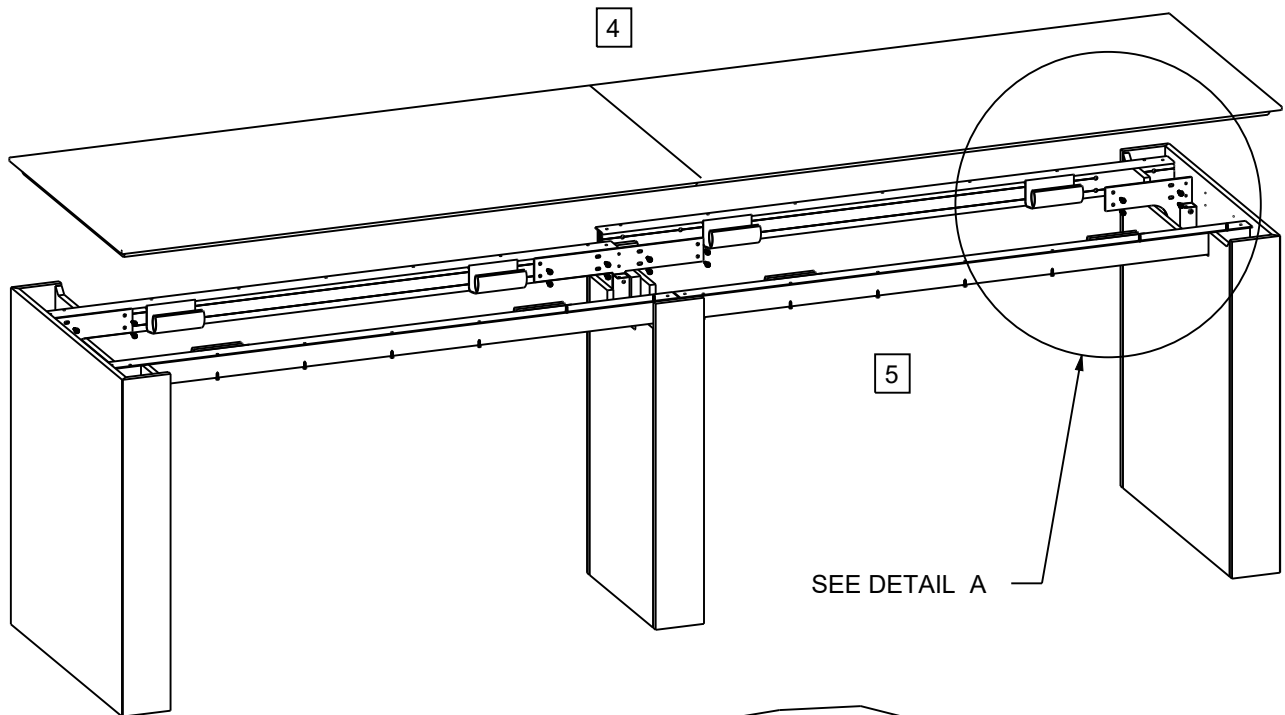

2

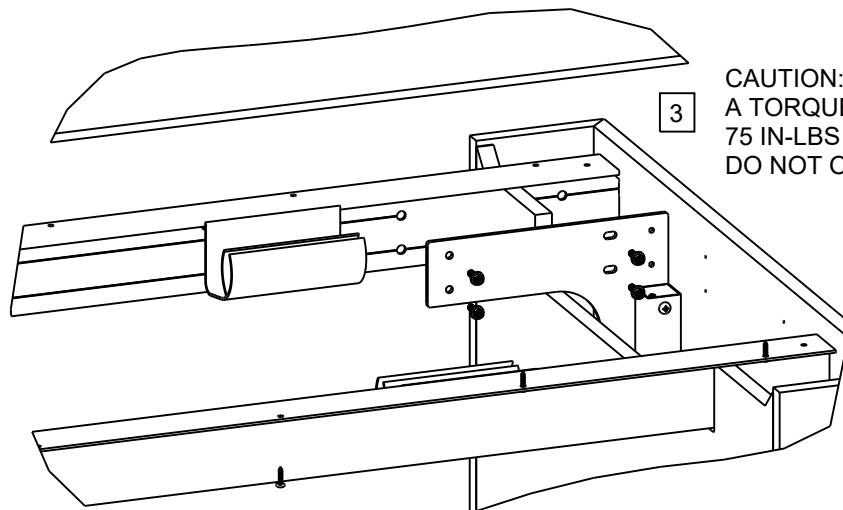

CAUTION: ASSEMBLE SCREWS TO  
A TORQUE SPEC OF  
75 IN-LBS (8.5 N-M)  
DO NOT OVER TORQUE THEM.

## GUNLOCKE

## GENERAL NOTES

1. ALWAYS PROTECT THE WORKSURFACE DURING INSTALLATION.
2. ALWAYS LEVEL UNITS(S) AT FINAL LOCATION.

## ATTACHMENT HARDWARE

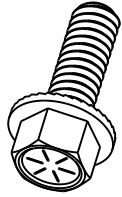

14-20X3/4 SERRATED HEX  
FLANGED WASHER



#10X3/4 PAN HEAD  
WOOD SCREW

- 1 STAND GEO BASE IN UPRIGHT POSITION
- 2 ATTACH GEO BASE BRACKETS TO BEAMS  
USING 1/4-20X3/4 SERRATED HEX FLANGED WASHERS
- 3 CENTER CONFERENCE TOP (LENGTH & WIDTH)  
ON BASE ASSEMBLY
- 4 ATTACH BEAMS TO CONFERENCE TOP  
USING 10X3/4" PAN HEAD WOOD SCREWS

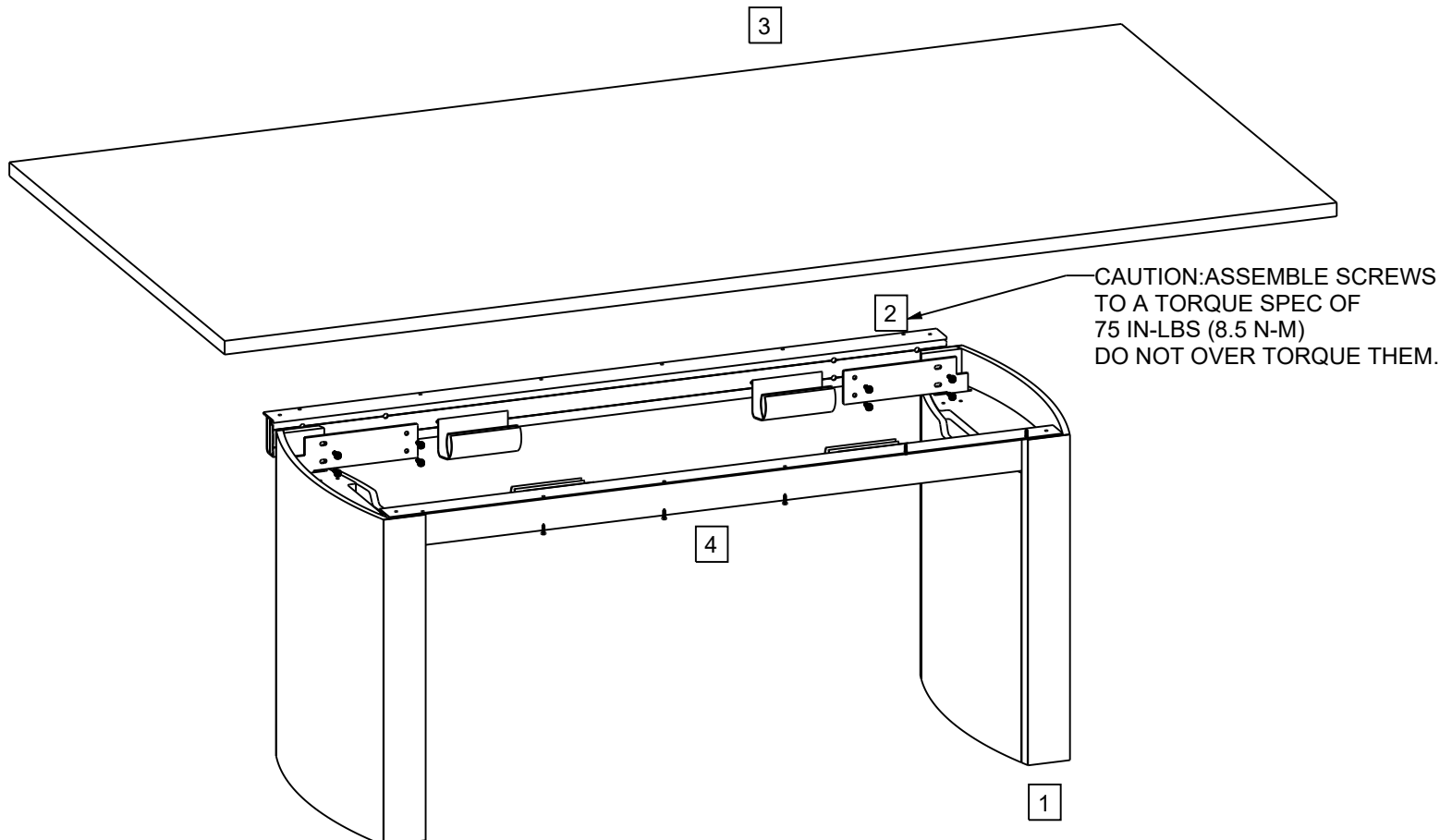



## GENERAL NOTES

1. ALWAYS PROTECT THE WORKSURFACE DURING INSTALLATION.
2. ALWAYS LEVEL UNITS(S) AT FINAL LOCATION.

- 1 STAND GEO BASE IN UPRIGHT POSITION
- 2 ATTACH GEO BASE BRACKETS TO BEAMS USING 1/4-20X3/4 SERRATED HEX FLANGED WASHERS
- 3 CENTER CONFERENCE TOP (LENGTH & WIDTH) ON BASE ASSEMBLY
- 4 ATTACH BEAMS TO CONFERENCE TOP USING 10X3/4" PAN HEAD WOOD SCREWS

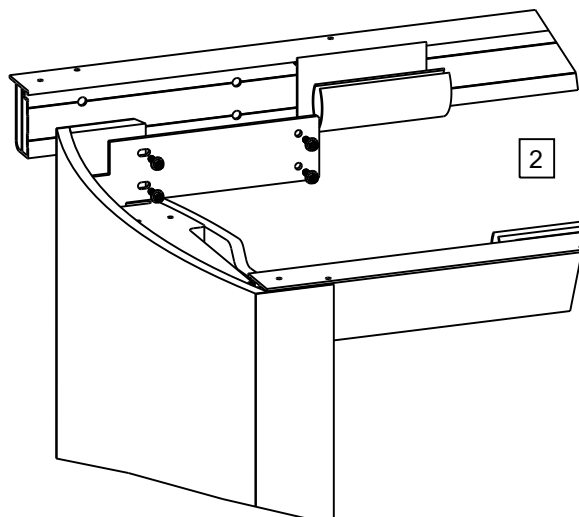
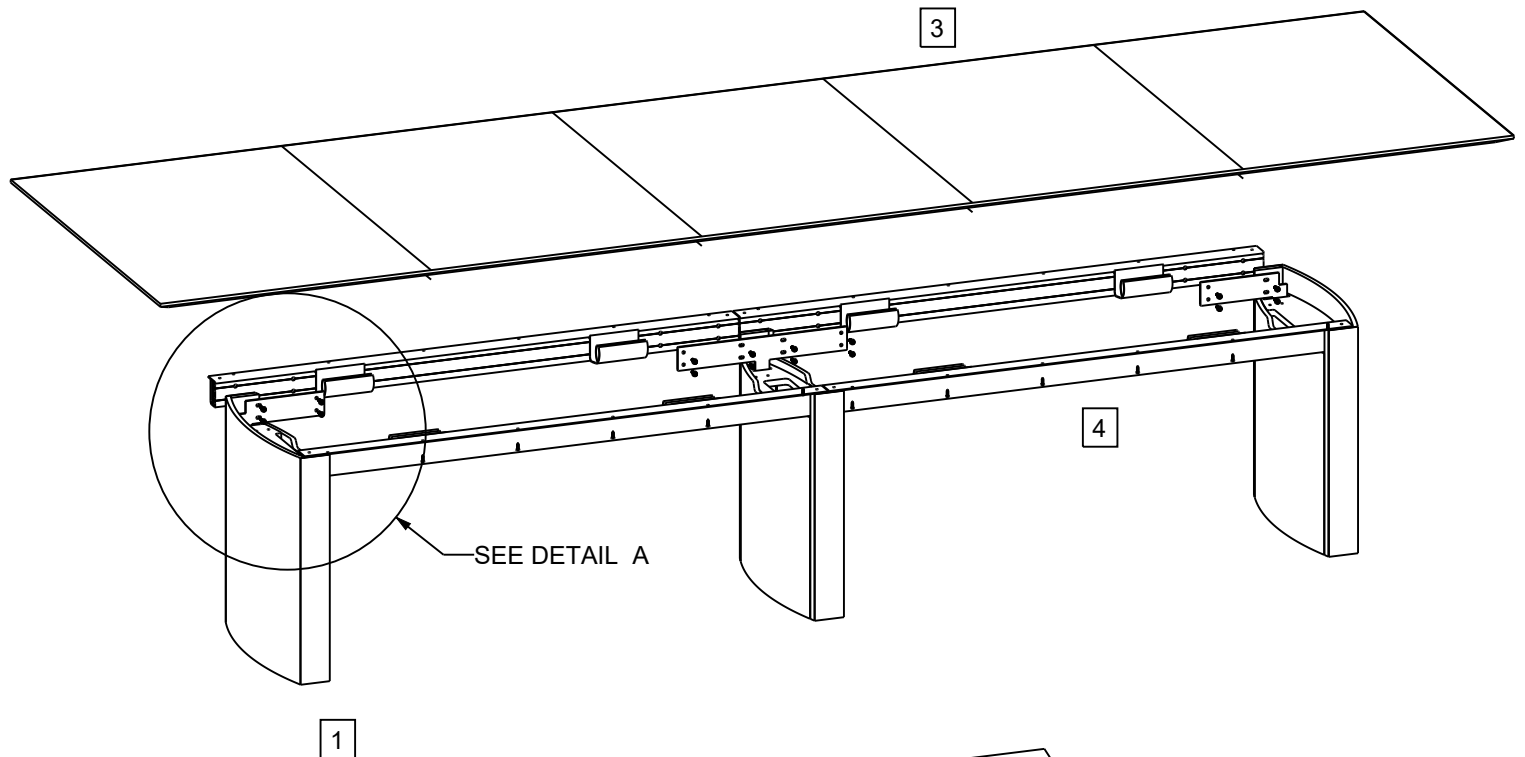

CAUTION: ASSEMBLE SCREWS TO A TORQUE SPEC OF 75 IN-LBS (8.5 N-M) DO NOT OVER TORQUE THEM.

# BRIEFING

## LEG BASE ASSEMBLY & ATTACHMENT

B2013-0008-00

# GUNLOCKE

PAGE 1

## GENERAL NOTES

1. ALWAYS PROTECT THE WORKSURFACE DURING INSTALLATION.
2. ALWAYS LEVEL UNITS(S) AT FINAL LOCATION.

## ATTACHMENT HARDWARE

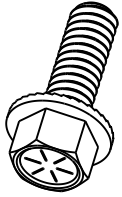

14-20X3/4 SERRATED HEX  
FLANGED WASHER



#10X3/4 PAN HEAD  
WOOD SCREW



#10X1 PAN HEAD  
WOOD SCREW

1 STAND LEG BASE IN UPRIGHT POSITION

2 ATTACH LEG BASE TO BEAMS  
USING 1/4-20X3/4 SERRATED HEX FLANGED WASHERS

3 CENTER CONFERENCE TOP (LENGTH & WIDTH)  
ON BASE ASSEMBLY

4 ATTACH BEAMS TO CONFERENCE TOP  
USING 10X3/4" PAN HEAD WOOD SCREWS

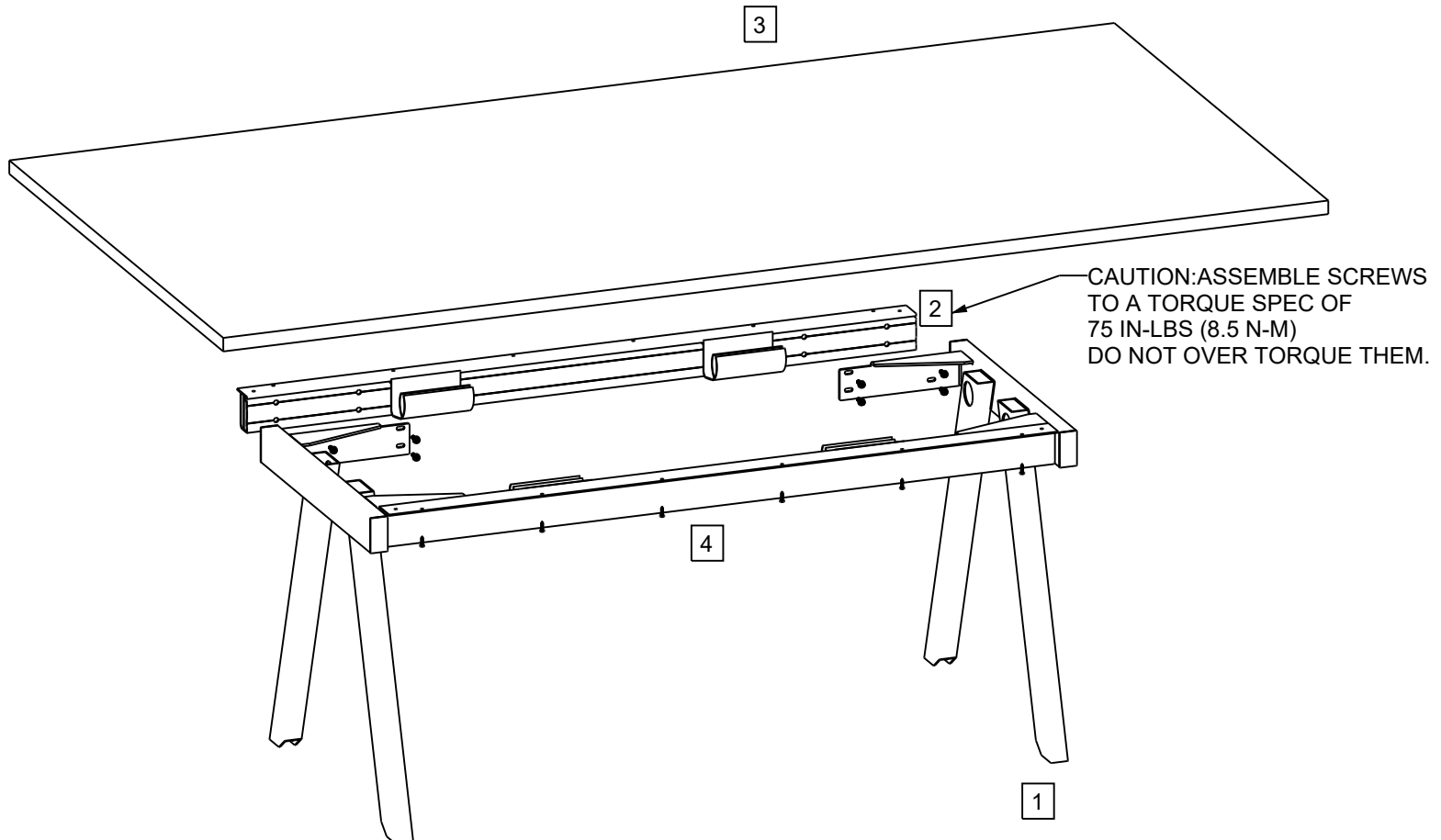

# BRIEFING

## LEG BASE ASSEMBLY & ATTACHMENT

B2013-0008-00

# GUNLOCKE

PAGE 2

## GENERAL NOTES

1. ALWAYS PROTECT THE WORKSURFACE DURING INSTALLATION.
2. ALWAYS LEVEL UNITS(S) AT FINAL LOCATION.

1 STAND LEG BASE IN UPRIGHT POSITION

2 ATTACH BRACKETS TO CENTER BASE USING  
10X1" PAN HEAD WOOD SCREWS

3 ATTACH LEG BASE TO BEAMS  
USING 1/4-20X3/4 SERRATED HEX FLANGED WASHERS

4 CENTER CONFERENCE TOP (LENGTH & WIDTH)  
ON BASE ASSEMBLY

5 ATTACH BEAMS TO CONFERENCE TOP  
USING 10X3/4" PAN HEAD WOOD SCREWS

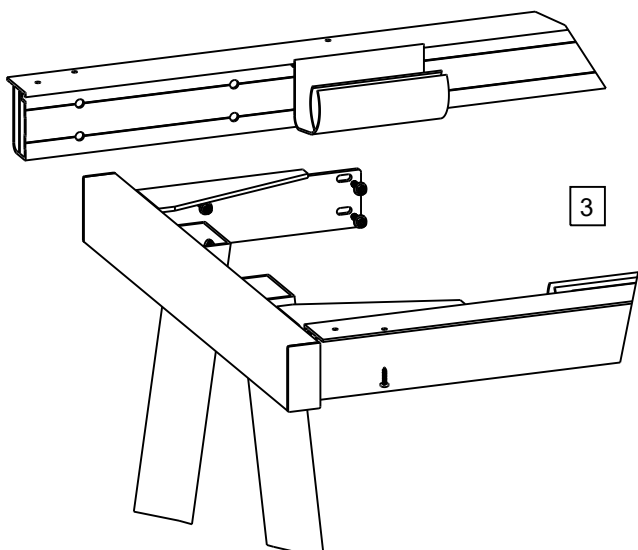
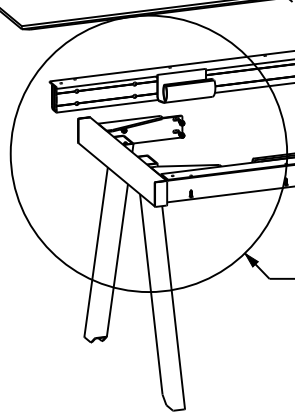
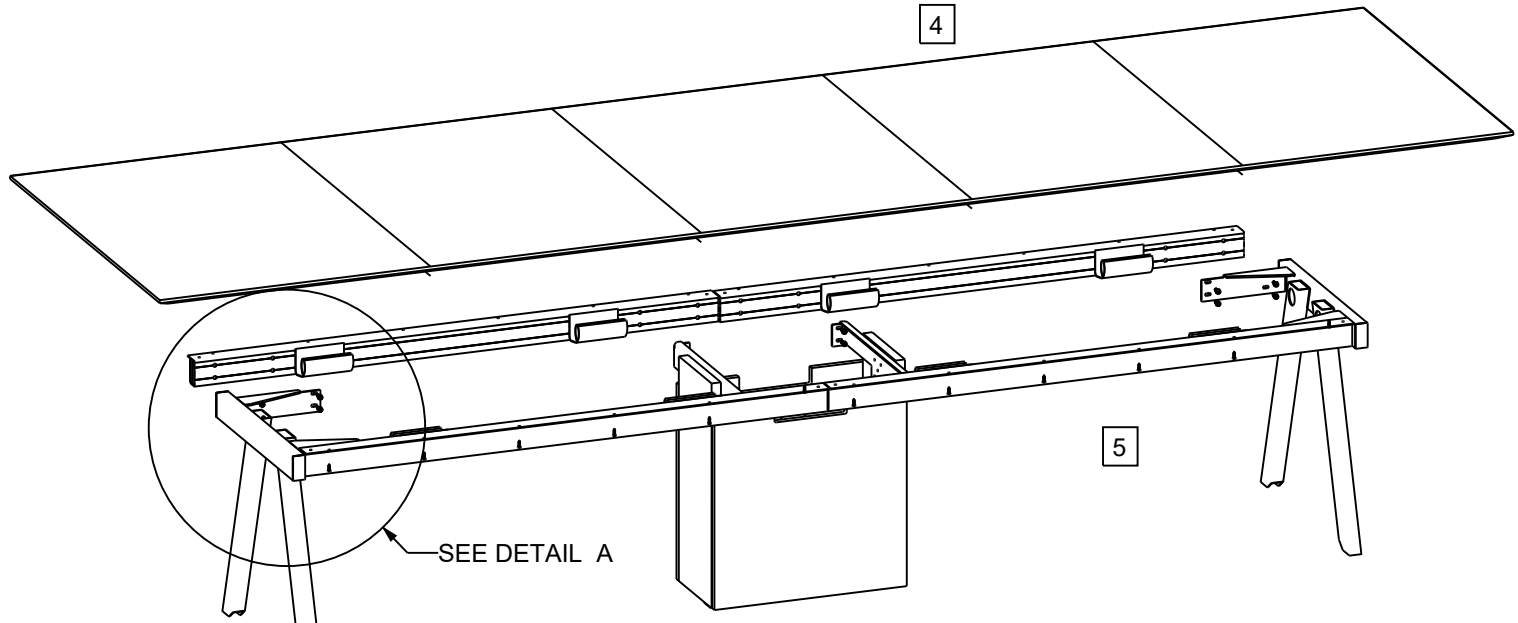
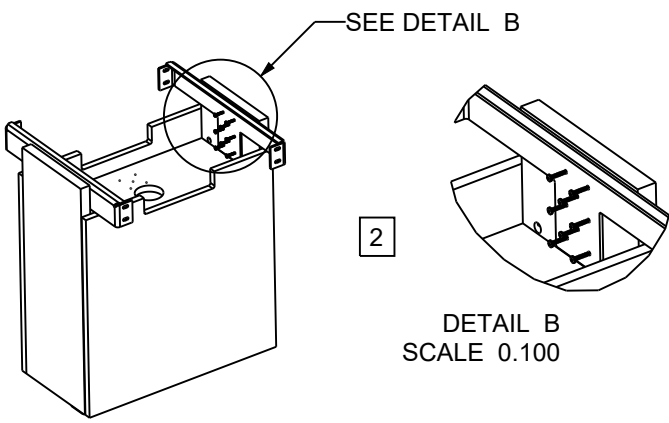

CAUTION: ASSEMBLE SCREWS  
TO A TORQUE SPEC OF  
75 IN-LBS (8.5 N-M)  
DO NOT OVER TORQUE THEM.

## 1 INSTALL HGT ADJ ELECTRICAL COMPONENTS

- ATTACH COMPONENTS TO BOTTOM OF TOP
- ATTACH CONTROL BOX, CENTER ON WIDTH,BELOW CUTOUT OR APPROXIMATELY 9" FROM BASE END USING 2" FH WOOD SCREWS
- ATTACH 4 CABLE MOTORS TO CONTROL BOX;  
ONE SET OF MOTORS ON THE FREESTANDING BASE WILL PLUG INTO \*S 3 & 4  
OTHER SET OF MOTORS ON BASE ATTACHED TO WALL WILL USE \*S 1 & 2
- ATTACH CONTROLLER TO UNDERSIDE OF TOP OR SUBTOP WITH CONTROLLER PADDLE SLIGHTLY INSET FROM EDGE USING #10X5/8 WOOD SCREWS  
PLUG CONTROLLER LEAD INTO \* A1 ON CONTROL BOX  
USE WIRE CLIPS TO SECURE ALL CABLES EXCEPT MAIN POWER CABLE
- PLUG IN MAIN CABLE POWER TO AC ON CONTROL BOX  
OPPOSITE END WILL SNAKE THRU BASE END INTO EITHER A FLOOR MONUMENT OR A WALL OUTLET
- ..DO NOT SECURE MAIN POWER CABLE WITH WIRE CLIPS..  
CABLE MUST BE FREE MOVING WITH HEIGHT ADJUSTABLE TABLE

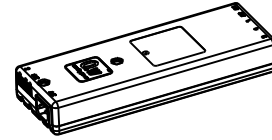

CONTROL BOX



CABLE MOTOR (QTY 4)

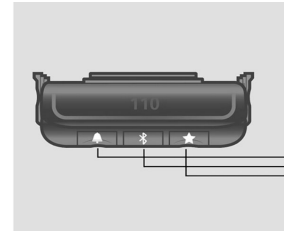

CONTROLLER



MAIN POWER CABLE

## 2 INSTALL THREADED INSERTS

- INSTALL GLIDES INTO LOWER BRACKETS
- ATTACH INSERTS INTO BACK OF WALL

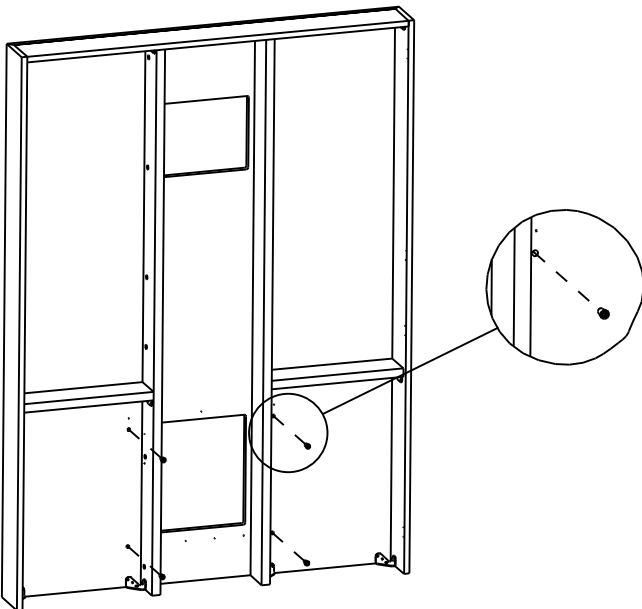

## 3 ATTACH BASE 1

- INSTALL GLIDES IN BASE
- REMOVE ACCESS DOOR
- BOLT THROUGH WELDMENT INTO THREADED INSERTS
- USE LONG BOLTS AT TOP, SHORT BOLTS AT BOTTOM
- DO NOT OVERTIGHTEN
- SECURE WITH WOOD SCREWS

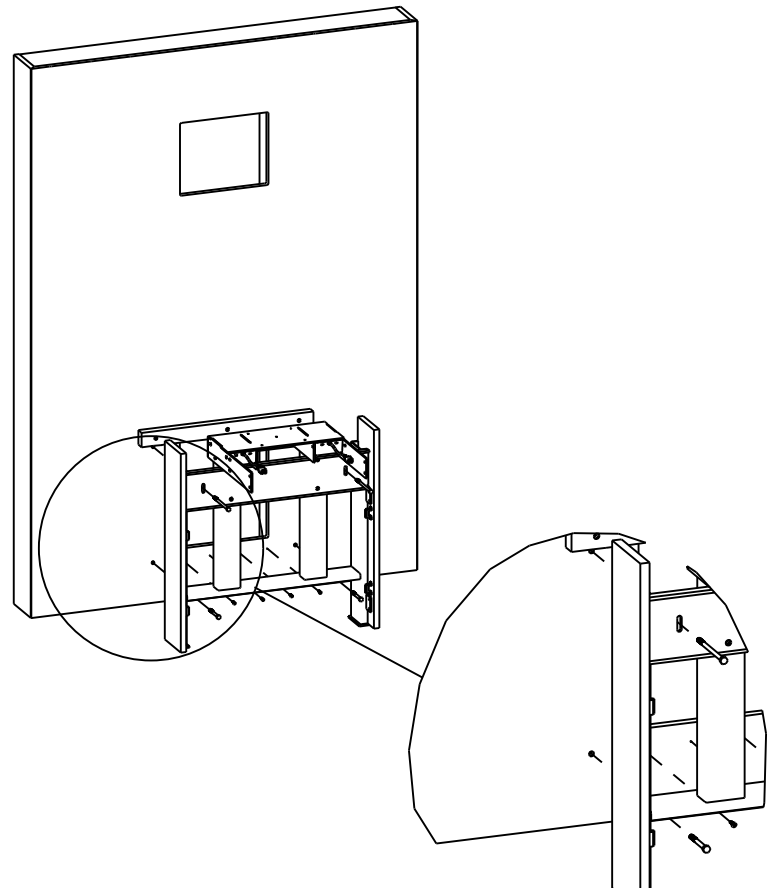

# 4 INSTALL WALL MOUNT COMPONENTS

- ★ IF UNIT DOES NOT HAVE A FINISHED BACK
- ATTACH "Z" BRACKET TO WALL (NOTE "A")
  - LOCATE "Z" BRACKET IN LOCATION APPROXIMATELY 58-1/2" FROM FLOOR
  - LEVEL MEDIA WALL & PUSH AGAINST WALL / BASEBOARD
  - SLIDE BOTH LH & RH "Z" HOOK BRACKETS OVER "Z" BRACKET, PUSH SNUG TO WALL UPRIGHT RAILS
  - ATTACH WALL ATTACHMENT BRACKETS TO MEDIA WALL USING #10X5/8 PAN HEAD SCREWS

NOTE "A"  
 GUNLOCKE ASSUMES NO RESPONSIBILITY FOR THE FASTENERS USED TO ATTACH BRACKET(S) TO THE WALL. IT IS THE RESPONSIBILITY OF THE INSTALLER / END USER TO DETERMINE THE APPROPRIATE METHOD OF ATTACHMENT BASED ON THE TYPE OF WALL MATERIAL AND OR STUDS AVAILABLE.

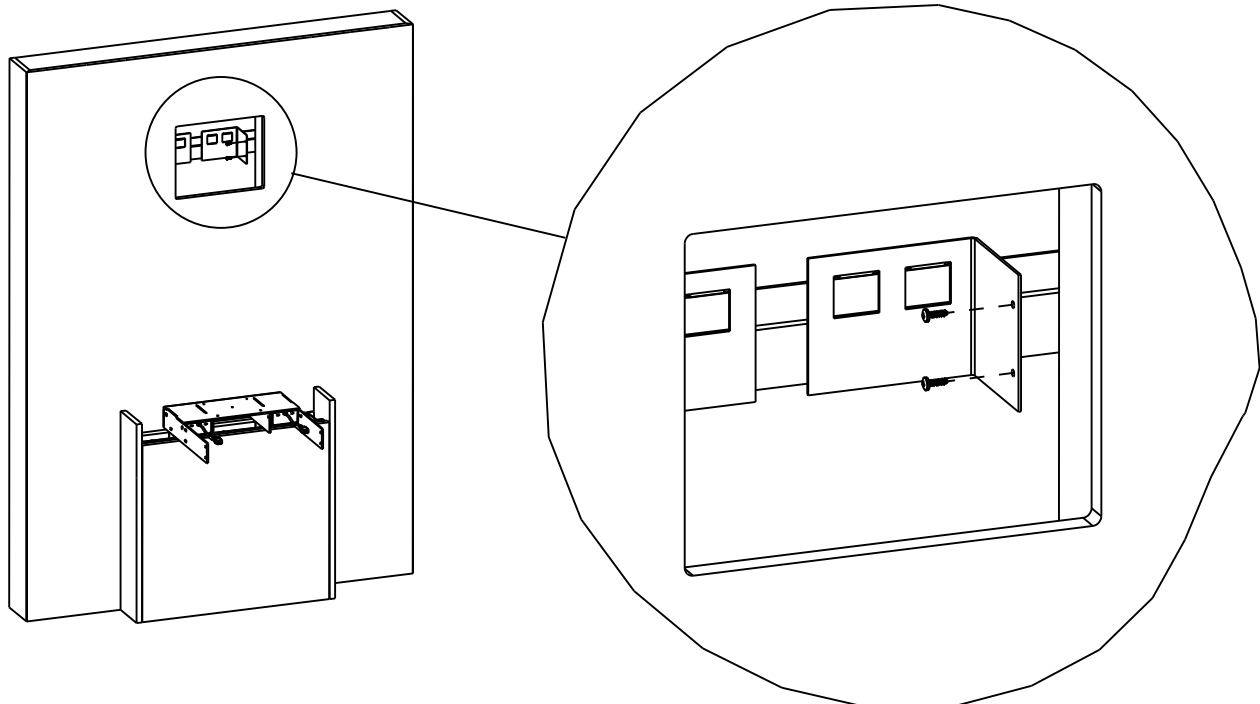
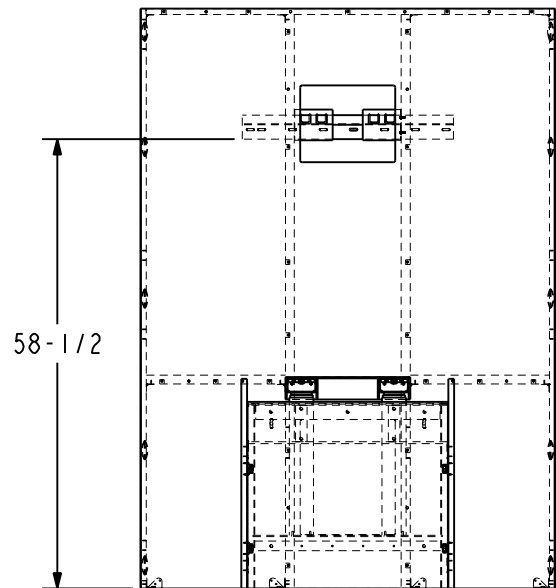

## 5 INSTALL BEAMS AND MITER BASE

-ATTACH BASES TO BEAMS USING 1/4-20X3/4 SERRATED HEX BOLTS W/ FLANGED WASHERS

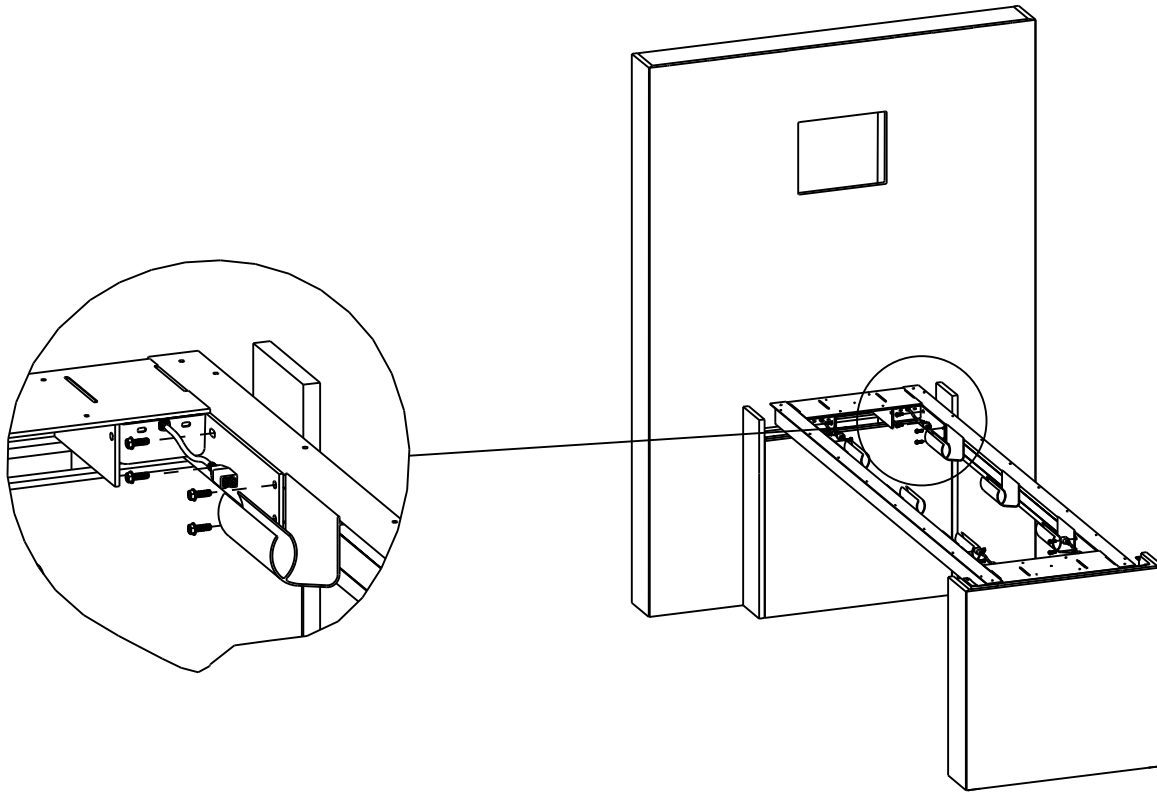

## 6 INSTALL TABLE TOP

- CENTER TOP (WIDTH) ON BASE ASSEMBLY, PUSH AGAINST WALL (LEAVE APPROXIMATELY 1/4" BETWEEN WALL AND TOP FOR ADJUSTABLE HEIGHT CLEARANCE)
- ATTACH BEAM ASSEMBLY TO TOP USING 10X3/4" PAN HEAD WOOD SCREWS
- RAISE TOP AND INSTALL REMAINING WOOD SCREWS AND BOLTS

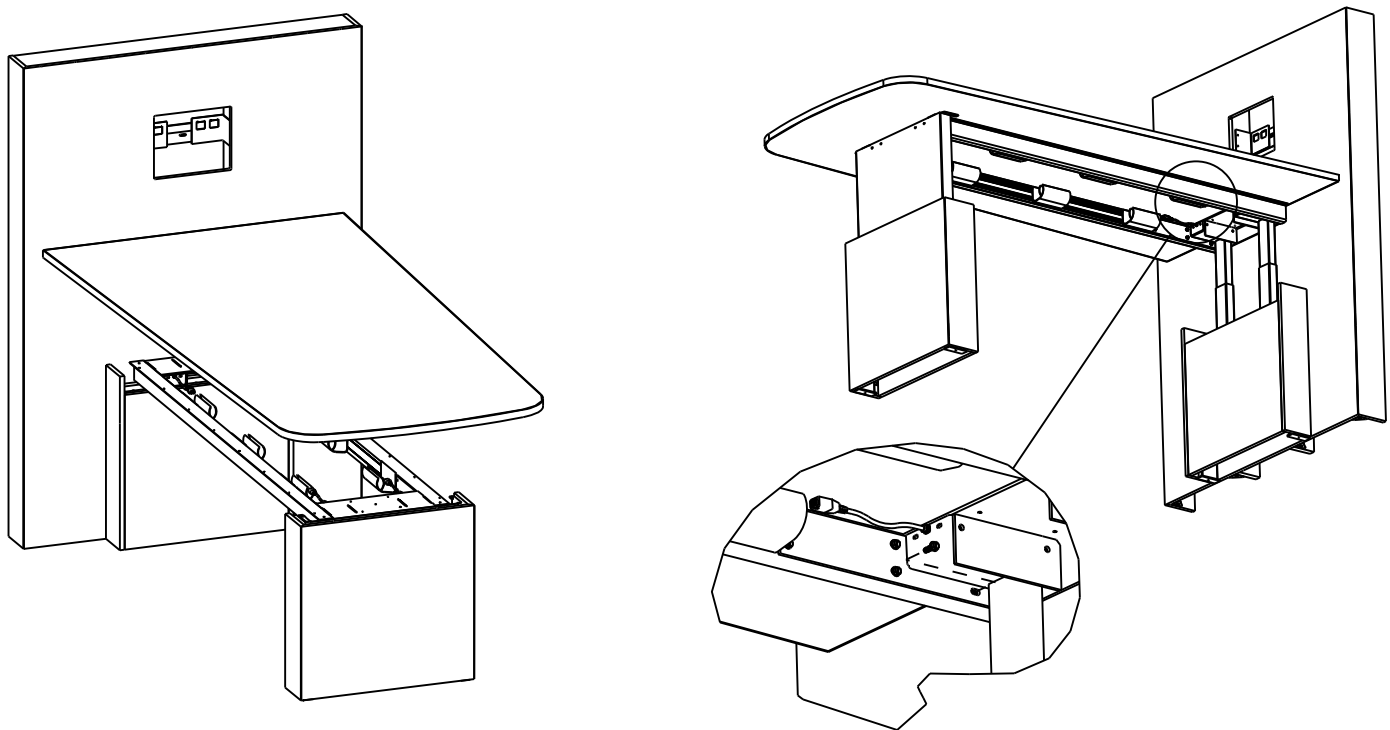

# BRIEFING EH MEDIA TABLE WHITE BOARD ASSEMBLY

B2013-0011-00

PAGE 1

## 1 INSTALL PLASTIC CLIPS TO WALL

- ATTACH STUD CLIPS TO WALL END PANELS
- ENSURE PROTRUSIONS ARE ORIENTED TOWARD THE BACK EDGES OF THE PANELS

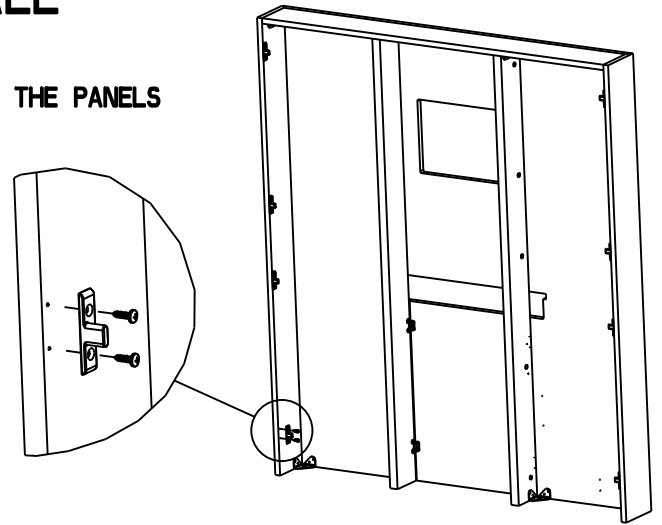

## 2 INSTALL PLASTIC CLIPS TO WHITE BOARD

- ATTACH SPADE CLIPS TO WHITE BOARDS
- ENSURE SPADES ARE ORIENTED TOWARD THE BOTTOM OF THE WHITE BOARD AS SHOWN

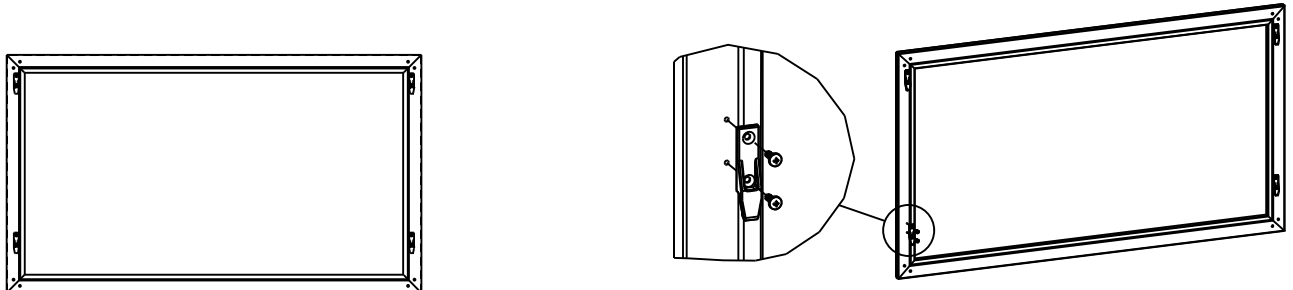

## 3 INSTALL WHITE BOARDS TO WALL

- CENTER LOWER WHITE BOARD ONTO WALL
- PUSH DOWN FIRMLY TO ENGAGE CLIPS
- REPEAT WITH UPPER WHITE BOARD

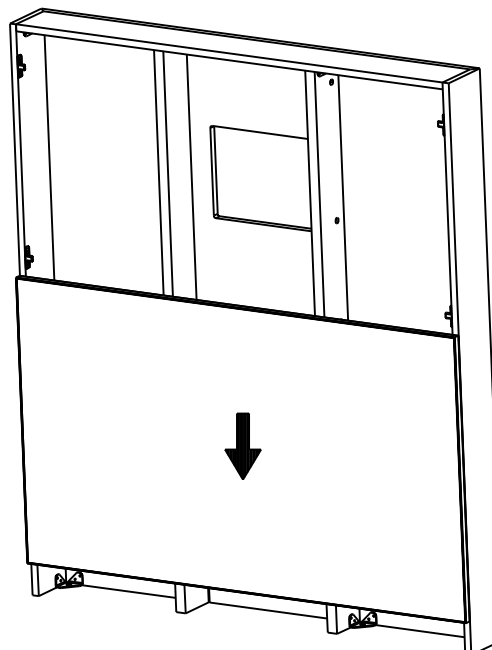

## 1 INSTALL BEAM ATTACHMENT BRACKETS

- INSTALL GLIDES IN LOWER BRACKETS
- REMOVE BRACKETS FROM BACK OF WALL
- ATTACH BRACKETS TO WALL UPRIGHTS USING #10X3/4" PAN HEAD SCREWS

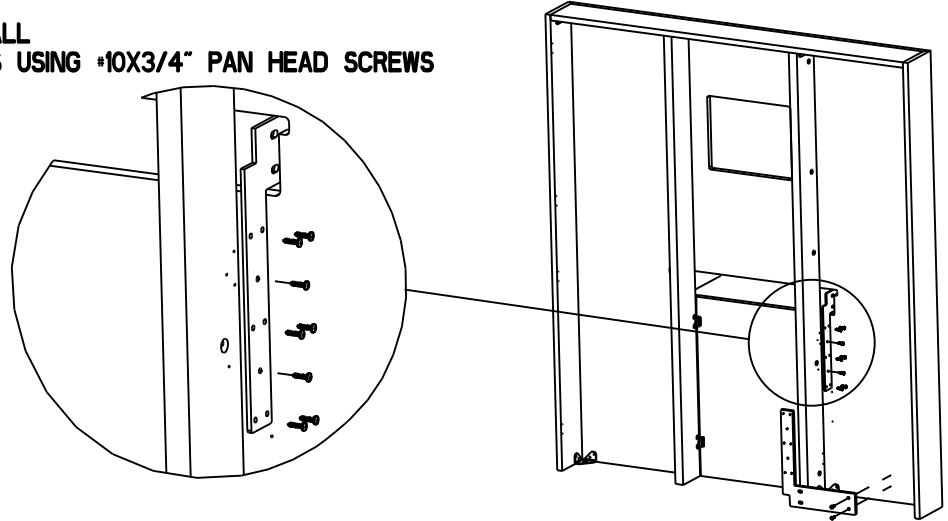

## 2 INSTALL WALL MOUNT COMPONENTS

- ★ IF UNIT DOES NOT HAVE A FINISHED BACK
  - ATTACH "Z" BRACKET TO WALL (NOTE "A")
  - LOCATE "Z" BRACKET IN LOCATION APPROXIMATELY FROM FLOOR:
    - 44" STANDARD HEIGHT
    - 58-1/2" TALL HEIGHT
  - LEVEL MEDIA WALL & PUSH AGAINST WALL / BASEBOARD
  - SLIDE BOTH LH & RH "Z" HOOK BRACKETS OVER "Z" BRACKET, PUSH SNUG TO WALL UPRIGHT RAILS
  - ATTACH WALL ATTACHMENT BRACKETS TO MEDIA WALL USING #10X5/8 PAN HEAD SCREWS

**NOTE "A"**  
GUNLOCKE ASSUMES NO RESPONSIBILITY FOR THE FASTENERS USED TO ATTACH BRACKET(S) TO THE WALL. IT IS THE RESPONSIBILITY OF THE INSTALLER / END USER TO DETERMINE THE APPROPRIATE METHOD OF ATTACHMENT BASED ON THE TYPE OF WALL MATERIAL AND OR STUDS AVAILABLE.

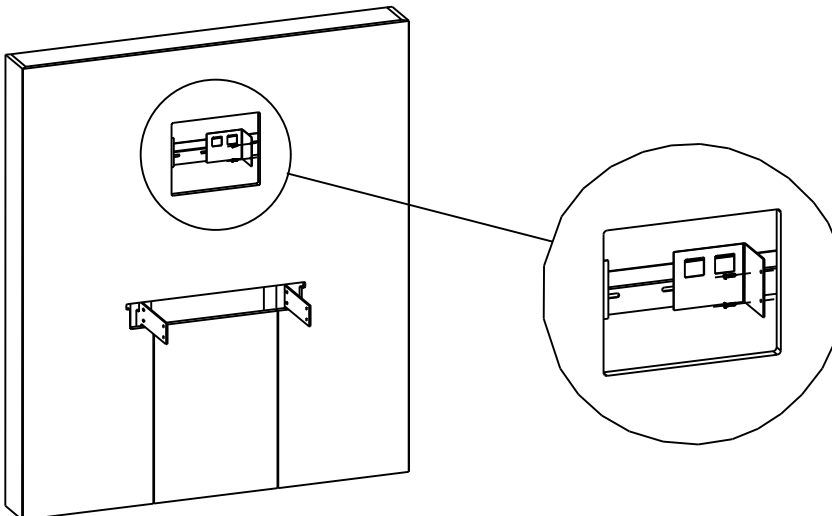
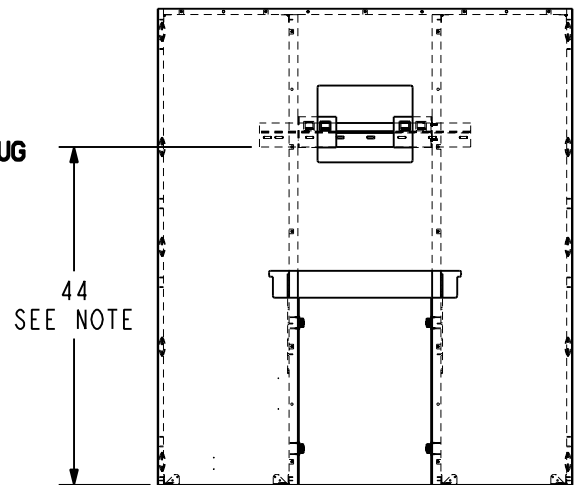



### 3 INSTALL BEAM ATTACHMENT BRACKETS

- REMOVE ACCESS DOOR
- INSTALL GLIDES IN SQUARE TUBES
- REMOVE BRACKETS FROM BACK PANEL
- ATTACH BRACKETS TO WALL UPRIGHTS USING PAN HEAD MACHINE SCREWS

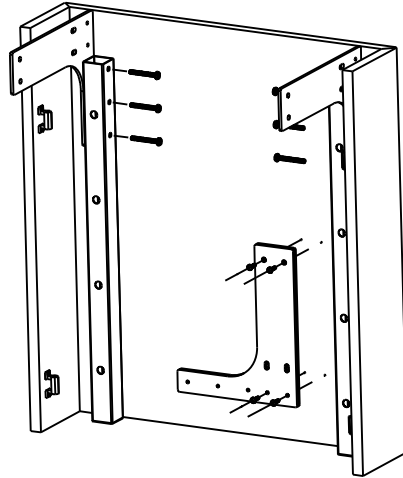

### 4 ATTACH BEAMS TO MITER BASE ASSEMBLY

- ATTACH BASE TO BEAMS USING 1/4-20X3/4 SERRATED HEX BOLTS W/ FLANGED WASHERS

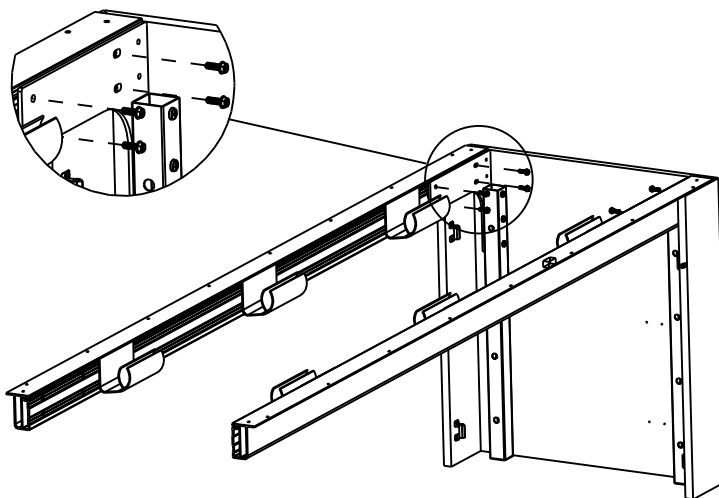

## 5 ATTACH MITER BASE ASSEMBLY TO WALL

- SLIDE BASE ASSEMBLY TO WALL
- ALIGN L BRACKET HOLES WITH BEAMS
- ATTACH BEAMS TO WALL USING 1/4-20X3/4 SERRATED HEX BOLTS W/ FLANGED WASHERS
- LEVEL BASE ASSEMBLY

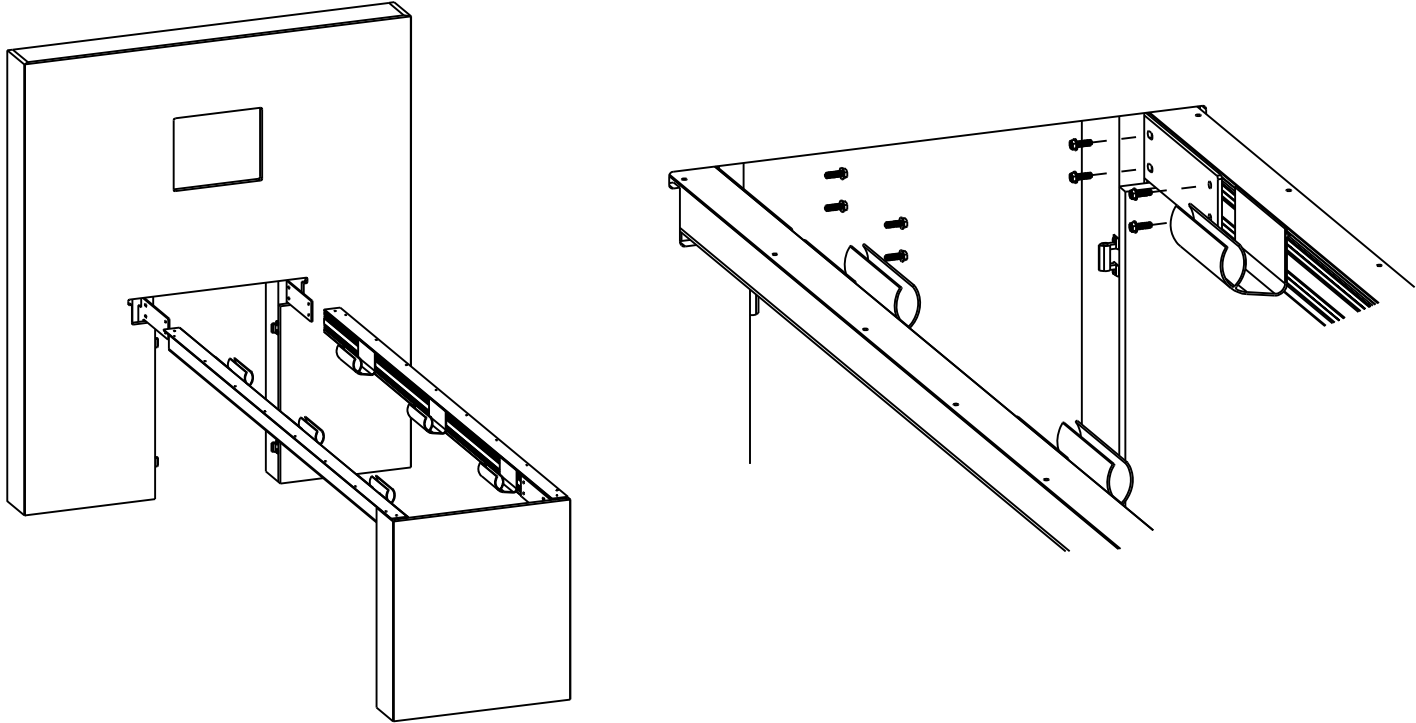

## 6 INSTALL TABLE TOP

- CENTER TOP (WIDTH) ON BASE ASSEMBLY, PUSH AGAINST WALL
- ATTACH BEAM ASSEMBLY TO TOP USING 10X3/4" PAN HEAD WOOD SCREWS

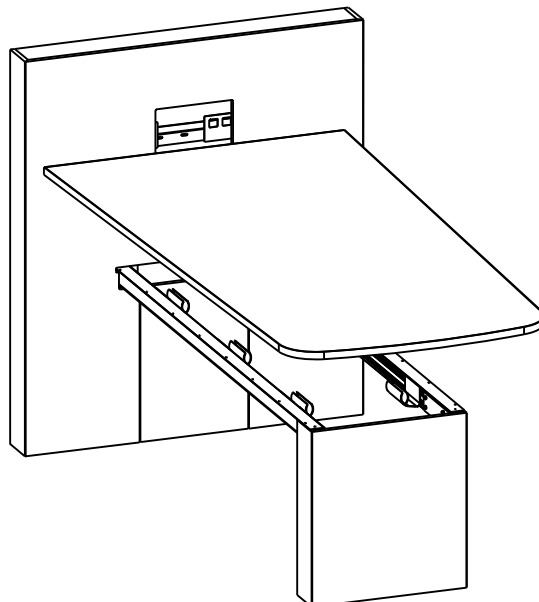

## 1 INSTALL BEAM ATTACHMENT BRACKETS

- INSTALL GLIDES IN LOWER BRACKETS
- REMOVE BRACKETS FROM BACK OF WALL
- ATTACH BRACKETS TO WALL UPRIGHTS USING #10X3/4" PAN HEAD SCREWS

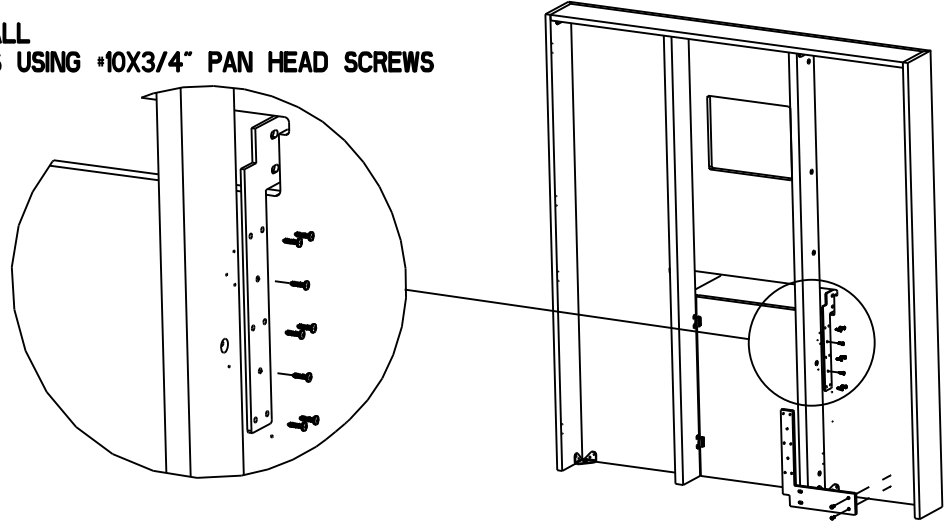

## 2 INSTALL WALL MOUNT COMPONENTS

- ★ IF UNIT DOES NOT HAVE A FINISHED BACK
- ATTACH "Z" BRACKET TO WALL (NOTE "A")
- LOCATE "Z" BRACKET IN LOCATION APPROXIMATELY FROM FLOOR:
  - 44" STANDARD HEIGHT
  - 58-1/2" TALL HEIGHT
- LEVEL MEDIA WALL & PUSH AGAINST WALL / BASEBOARD
- SLIDE BOTH LH & RH "Z" HOOK BRACKETS OVER "Z" BRACKET, PUSH SNUG TO WALL UPRIGHT RAILS
- ATTACH WALL ATTACHMENT BRACKETS TO MEDIA WALL USING #10X5/8 PAN HEAD SCREWS

NOTE "A"  
GUNLOCKE ASSUMES NO RESPONSIBILITY FOR THE FASTENERS USED TO ATTACH BRACKET(S) TO THE WALL. IT IS THE RESPONSIBILITY OF THE INSTALLER / END USER TO DETERMINE THE APPROPRIATE METHOD OF ATTACHMENT BASED ON THE TYPE OF WALL MATERIAL AND OR STUDS AVAILABLE.

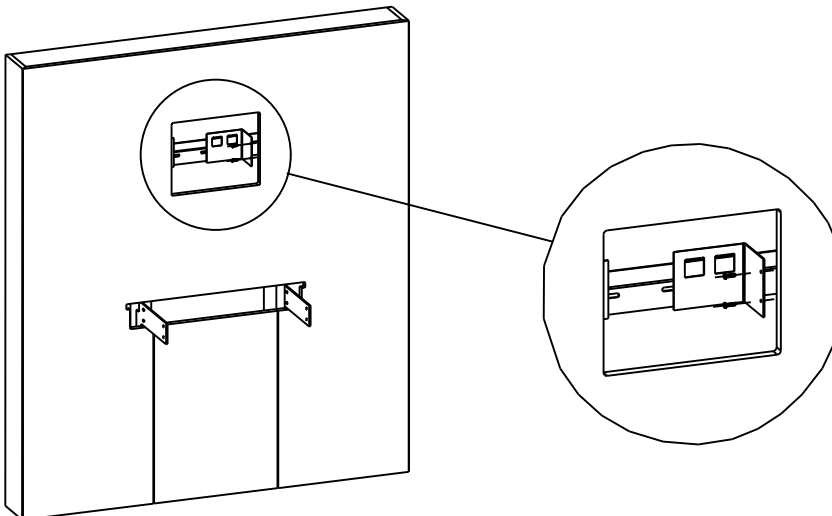
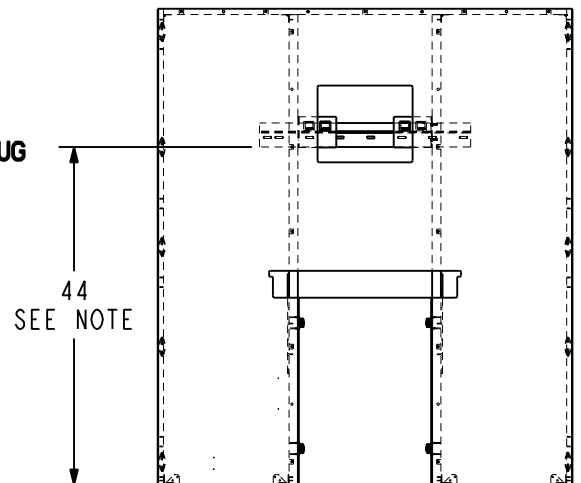

### 3 ASSEMBLE Y BASE AND ATTACH TOP PLATE

- ASSEMBLE Y BASE PER INSTRUCTIONS
- ATTACH BASE TO PLATE USING FLAT HEAD MACHINE SCREWS AND HEX NUTS

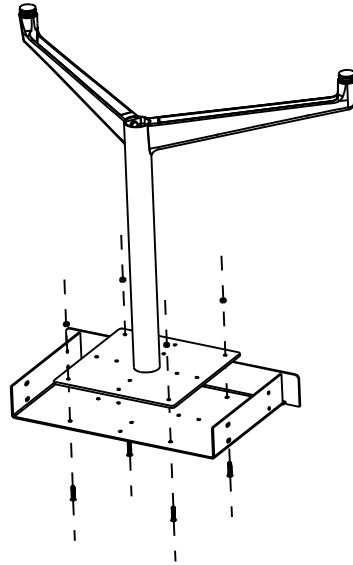

### 4 ATTACH BEAMS TO Y BASE ASSEMBLY

- ATTACH BASE TO BEAMS USING 1/4-20X3/4 SERRATED HEX BOLTS W/ FLANGED WASHERS

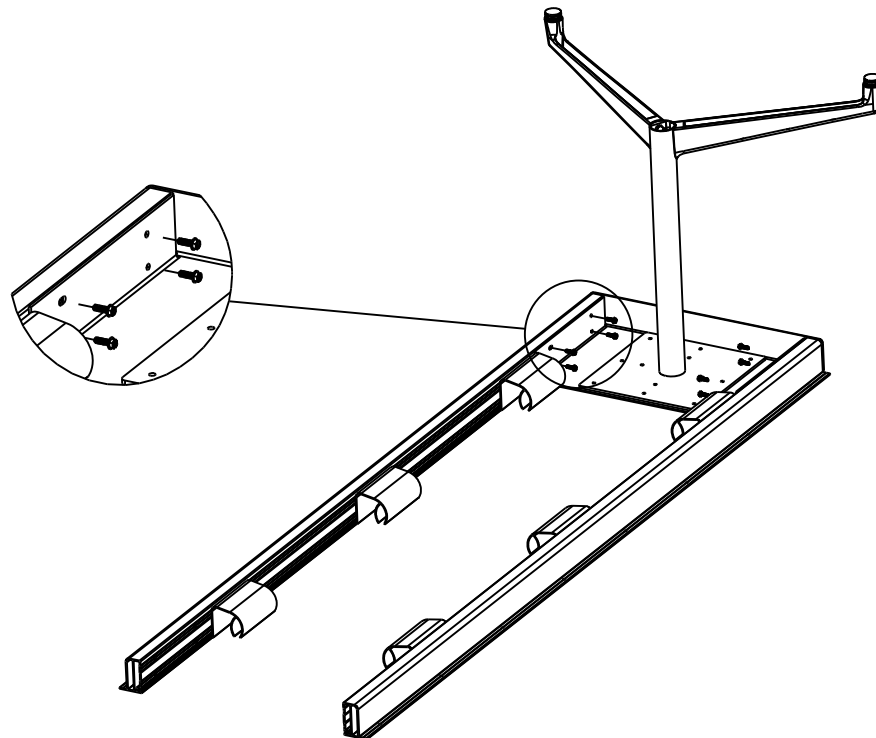

## 5 ATTACH Y BASE ASSEMBLY TO WALL

- SLIDE BASE ASSEMBLY TO WALL
- ALIGN L BRACKET HOLES WITH BEAMS
- ATTACH BEAMS TO WALL USING 1/4-20X3/4 SERRATED HEX BOLTS W/ FLANGED WASHERS
- LEVEL BASE ASSEMBLY

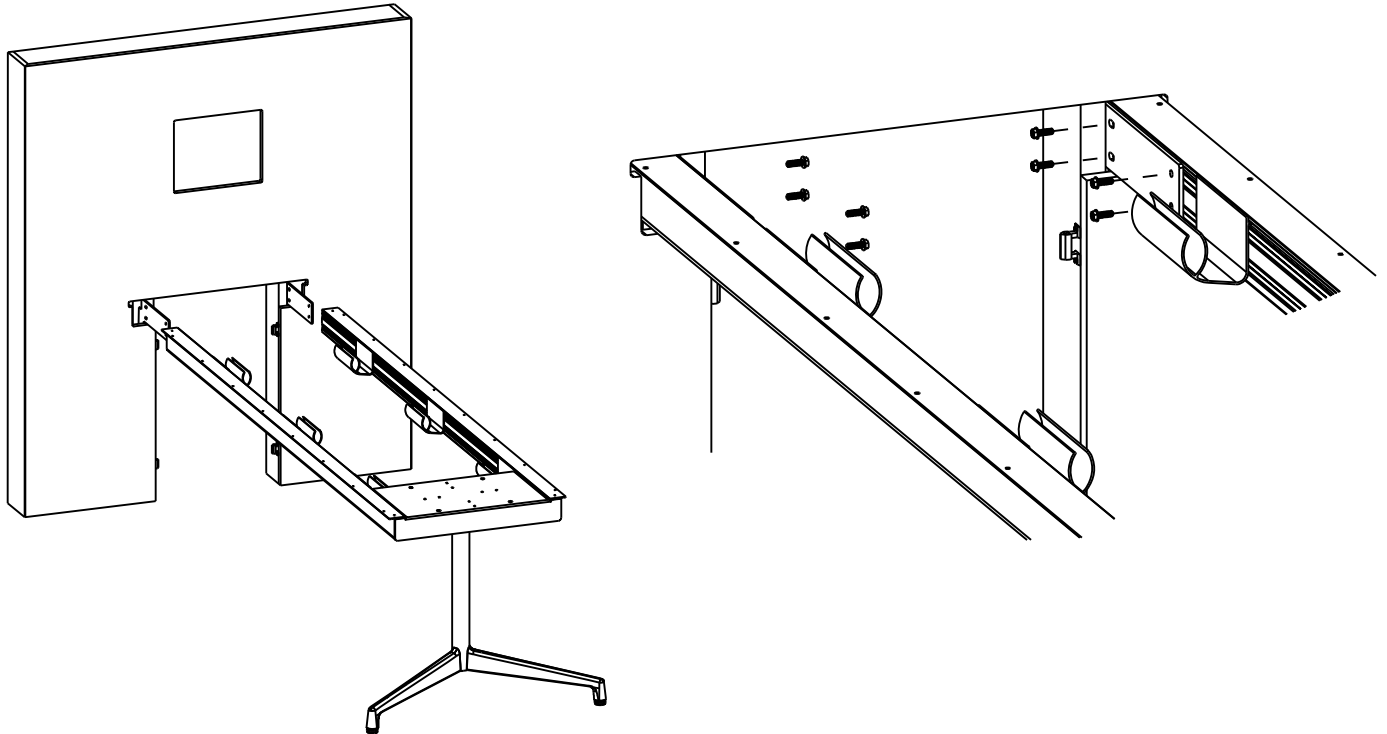

## 6 INSTALL TABLE TOP

- CENTER TOP (WIDTH) ON BASE ASSEMBLY, PUSH AGAINST WALL
- ATTACH BEAM ASSEMBLY TO TOP USING 10X3/4" PAN HEAD WOOD SCREWS

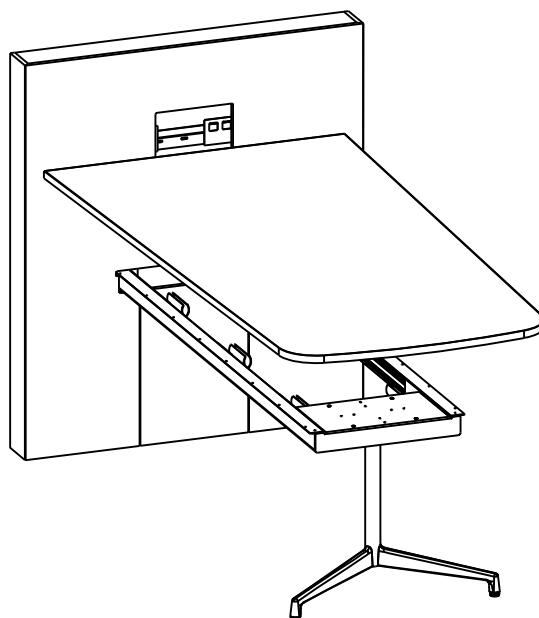

## GENERAL NOTES

1. ALWAYS PROTECT THE WORKSURFACE DURING INSTALLATION.
2. ALWAYS LEVEL UNITS(S) AT FINAL LOCATION.

## ATTACHMENT HARDWARE

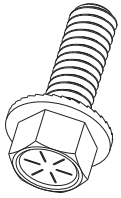

1/4-20X3/4 SERRATED HEX  
FLANGED WASHER



#10X3/4 PAN HEAD  
WOOD SCREW



#10X5/8 PAN HEAD  
WOOD SCREW

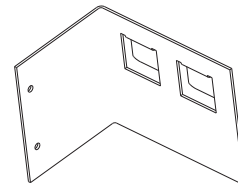

BRACKET LH & RH  
"Z" HOOK

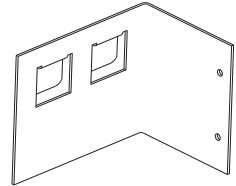

## 1 MEDIA WALL MOUNT BASE ATTACHMENT

- ATTACH MITER BASE & WELDMENT BRACKET TO BEAMS USING 1/4-20X3/4 SERRATED HEX FLANGED WASHERS
- PUSH ASSEMBLY AGAINST WALL, LEVEL & MOUNT (NOTE "A")
- CENTER TOP (LENGTH & WIDTH) ON BASE ASSEMBLY
- ATTACH BEAMS TO TOP USING 10X3/4" PAN HEAD WOOD SCREWS

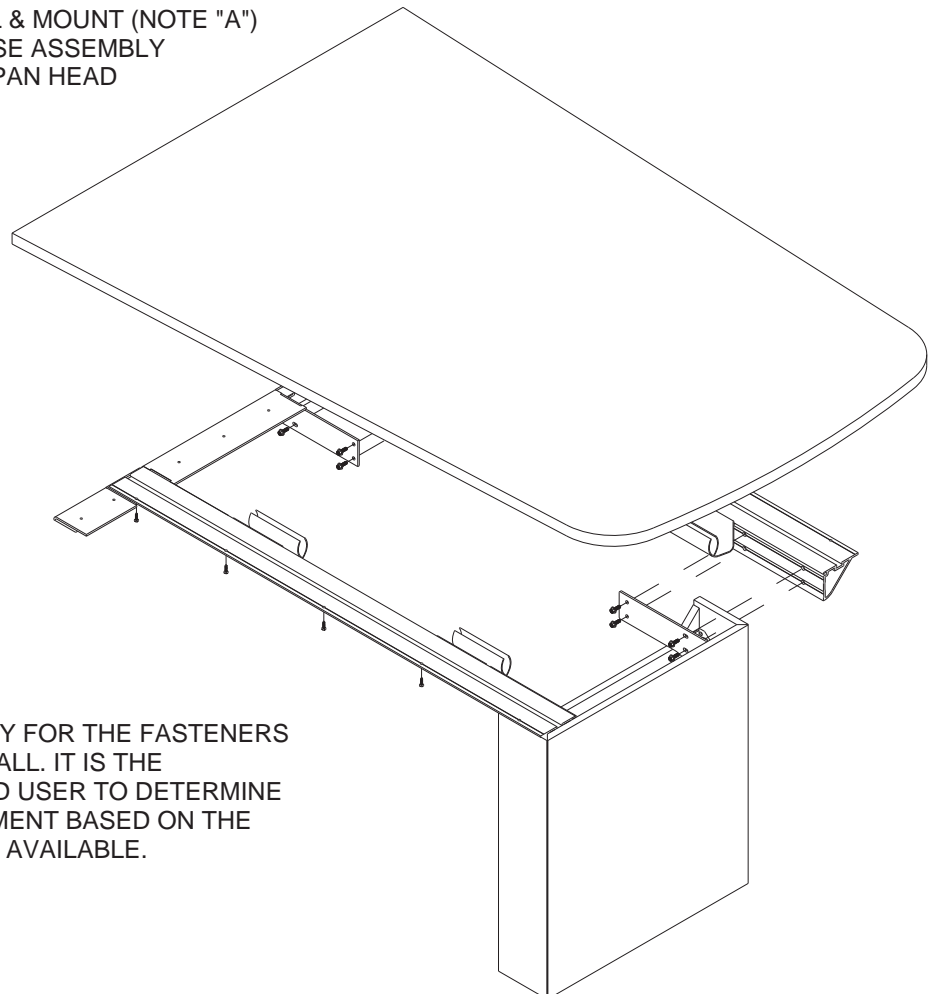

NOTE "A"  
GUNLOCKE ASSUMES NO RESPONSIBILITY FOR THE FASTENERS USED TO ATTACH BRACKET(S) TO THE WALL. IT IS THE RESPONSIBILITY OF THE INSTALLER / END USER TO DETERMINE THE APPROPRIATE METHOD OF ATTACHMENT BASED ON THE TYPE OF WALL MATERIAL AND OR STUDS AVAILABLE.

## GUNLOCKE

## GENERAL NOTES

1. ALWAYS PROTECT THE WORKSURFACE DURING INSTALLATION.
2. ALWAYS LEVEL UNITS(S) AT FINAL LOCATION.

## ATTACHMENT HARDWARE



#10X1-1/2 FLAT HEAD  
WOOD SCREW

## 1 FULL TAPER BASE ATTACHMENT

- STAND FULL TAPER BASE IN UPRIGHT POSITION
- CENTER CONFERENCE TOP (LENGTH & WIDTH)  
ON BASE ASSEMBLY
- ATTACH TAPER BASE SUBTOPS TO CONFERENCE TOP  
USING 10X1-1/2" FLAT HEAD WOOD SCREWS

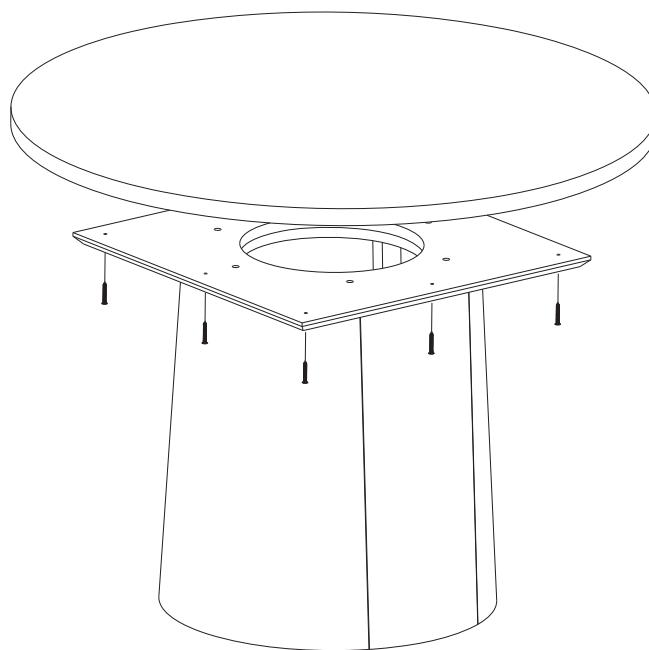

## GUNLOCKE

PAGE 1

## GENERAL NOTES

1. ALWAYS PROTECT THE WORKSURFACE DURING INSTALLATION.
2. ALWAYS LEVEL UNITS(S) AT FINAL LOCATION.

## ATTACHMENT HARDWARE



#10X3/4 PAN HEAD  
WOOD SCREW

### 1 HOOP BASE ATTACHMENT

- STAND HOOP BASE IN UPRIGHT POSITION
- CENTER CONFERENCE TOP (LENGTH & WIDTH)  
ON BASE ASSEMBLY
- ATTACH HOOP BASE TO CONFERENCE TOP  
USING 10X3/4 PAN HEAD WOOD SCREWS

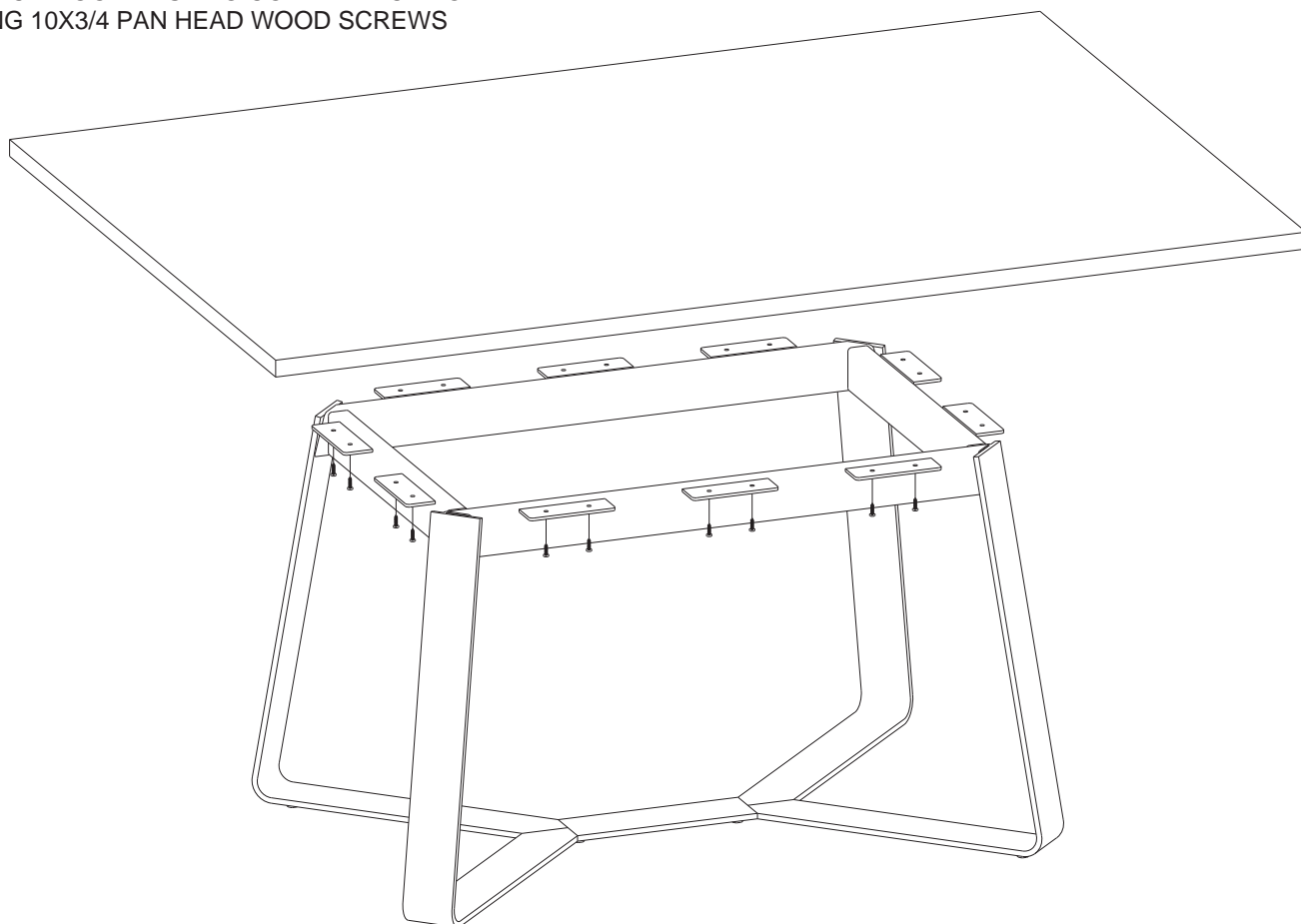



## GUNLOCKE

PAGE 2

### GENERAL NOTES

1. ALWAYS PROTECT THE WORKSURFACE DURING INSTALLATION.
2. ALWAYS LEVEL UNITS(S) AT FINAL LOCATION.

### 1 HOOP BASE X ATTACHMENT

- STAND HOOP BASE IN UPRIGHT POSITION
- CENTER CONFERENCE TOP (LENGTH & WIDTH)  
ON BASE ASSEMBLY
- ATTACH HOOP BASE TO CONFERENCE TOP  
USING 10X3/4 PAN HEAD WOOD SCREWS

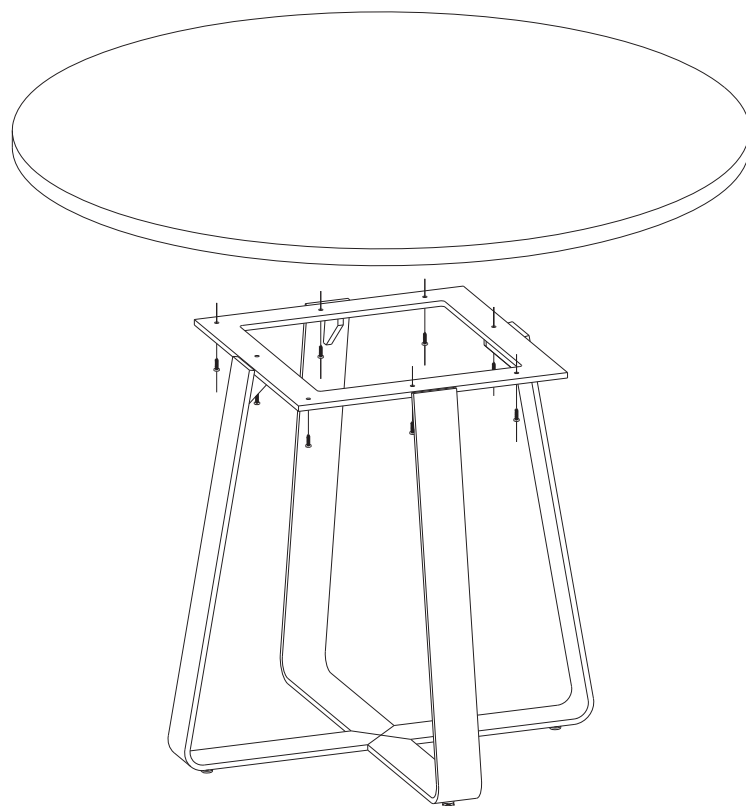

SCALE 0.080

## 1 ASSEMBLE Y BASE

-ASSEMBLE Y BASE PER INSTRUCTIONS

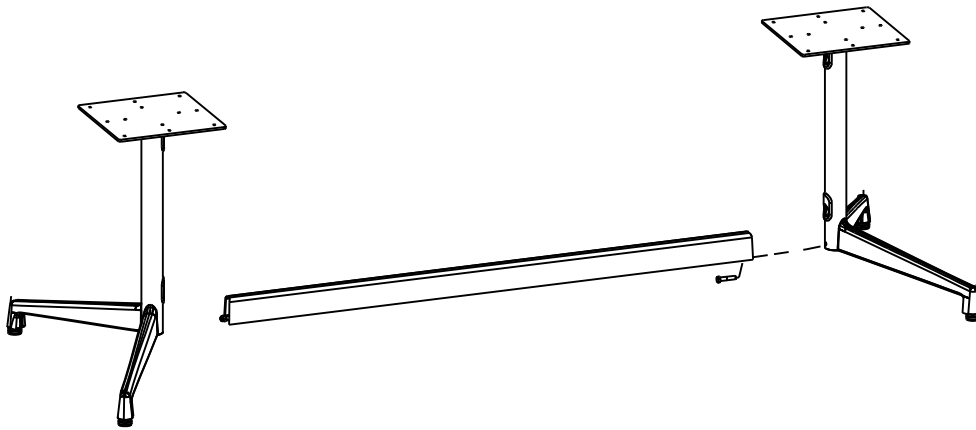

## 2 ATTACH TOP PLATES

-ATTACH PLATES TO BASE USING FLAT HEAD MACHINE SCREWS AND HEX NUTS

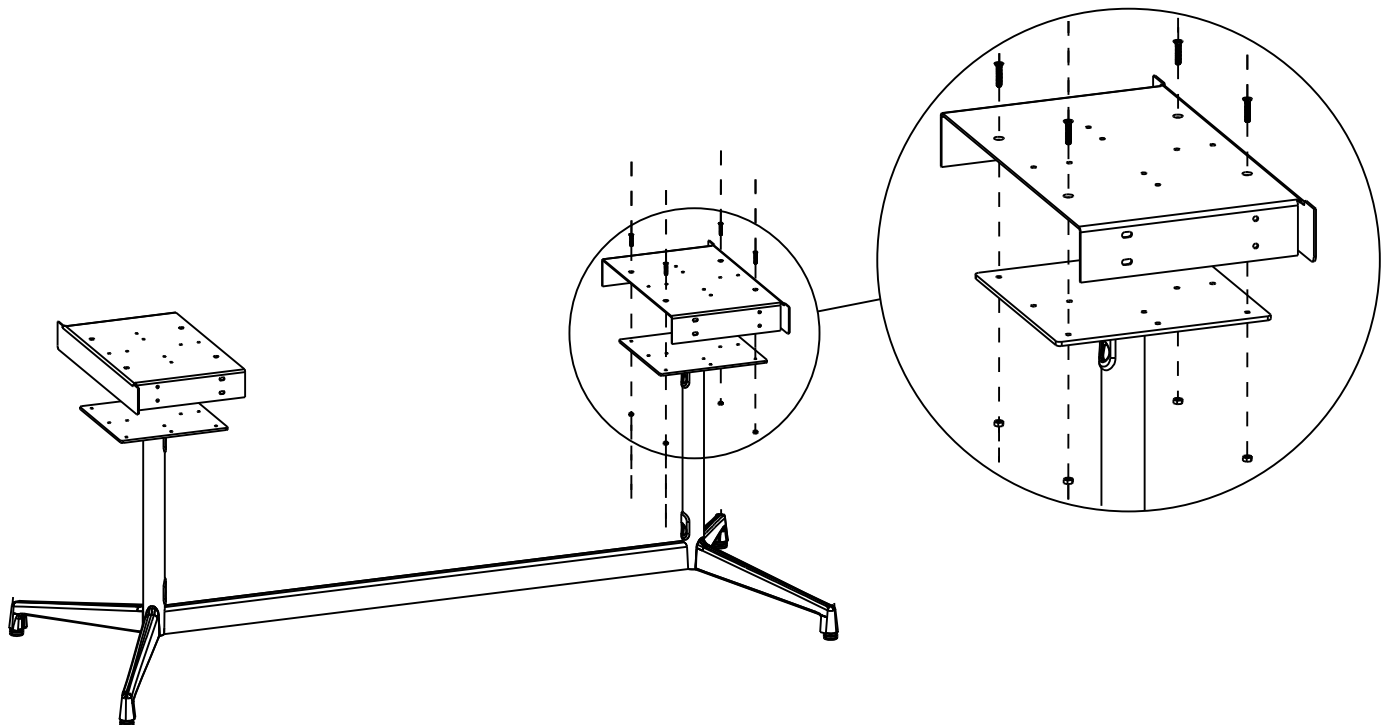

### 3 ATTACH BEAMS TO Y BASE ASSEMBLY

-ATTACH BASE TO BEAMS USING 1/4-20X3/4 SERRATED HEX BOLTS W/ FLANGED WASHERS

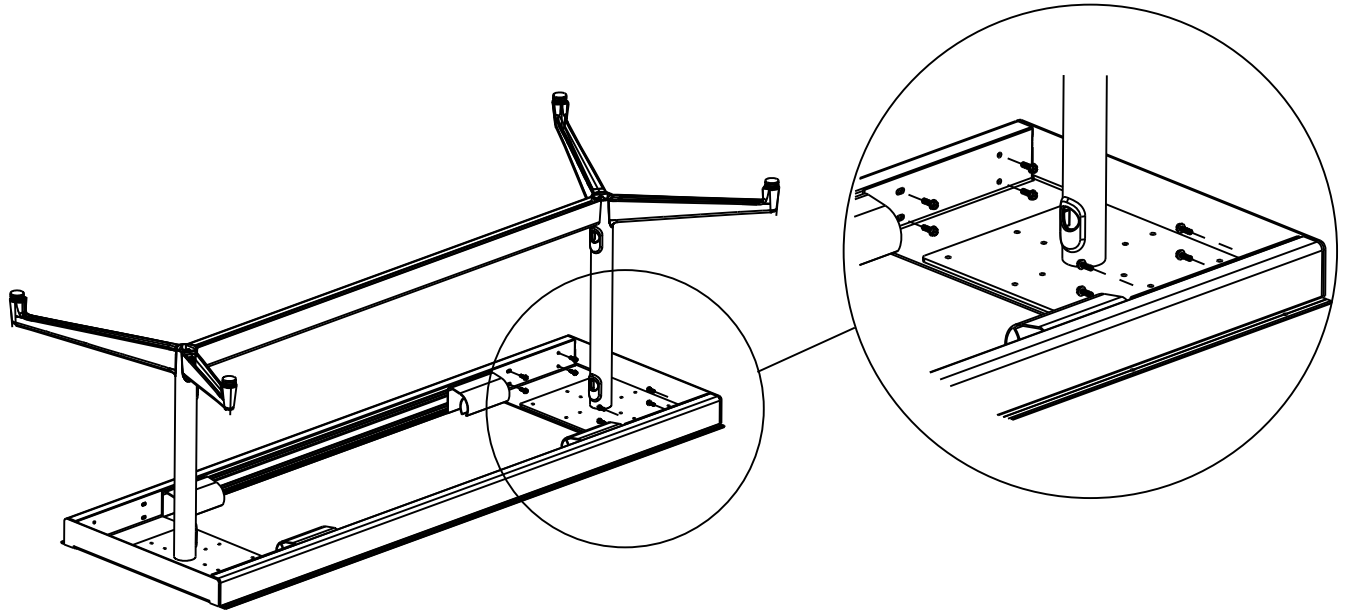

### 4 INSTALL TABLE TOP

-CENTER TOP ON BASE ASSEMBLY

-ATTACH BEAM ASSEMBLY TO TOP USING 10X3/4" PAN HEAD WOOD SCREWS

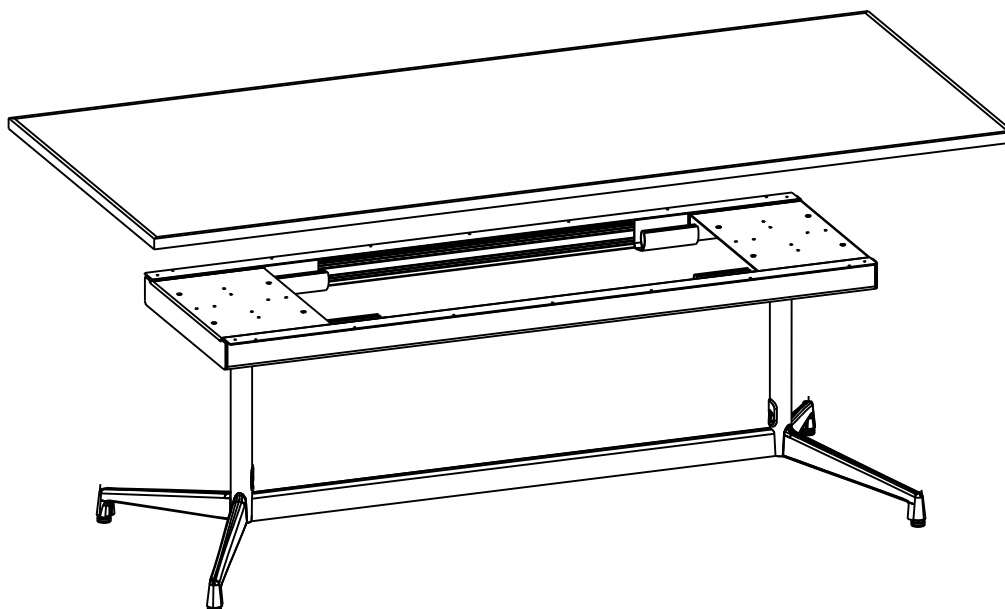

## ASSEMBLY INSTRUCTIONS - DuraCast Y, with Single Column DuraCast X, with Multiple Columns

- 1) Wrenches needed, two 9/16" open end or boy end wrenches.
- 2) Locate hardware pack(s) containing 4 bolts and 4 nuts packaged in a bag.
- 3) Locate hardware pack(s) of 4 spacers. Set mounting plates on flat surface.

### Assemble castins to column

- 1) See image below for orientation of mounting plate to the castings on "Y" shape bases.
- 2) See image below when assembling base with multiple post and stretchers.
- 3) Install bolt in casting as shown (reverse bolt direction if using 4" long casting).
- 4) Holding spacer and nut in one hand and casting in the other, place bolt through hole in the column, slide spacer onto bolt inside of tube as shown, assemble nut.
- 5) Tighten nut firmly using two 9/16 wrenches.
- 6) Assemble all other castings to all columns.
- 7) Assemble stretchers(s) to leg columns, tighten nuts and back off 1/8 turn.
- 8) Locate mounting plates on table top, screw plates to table top, tighten nuts on legs and stretchers.

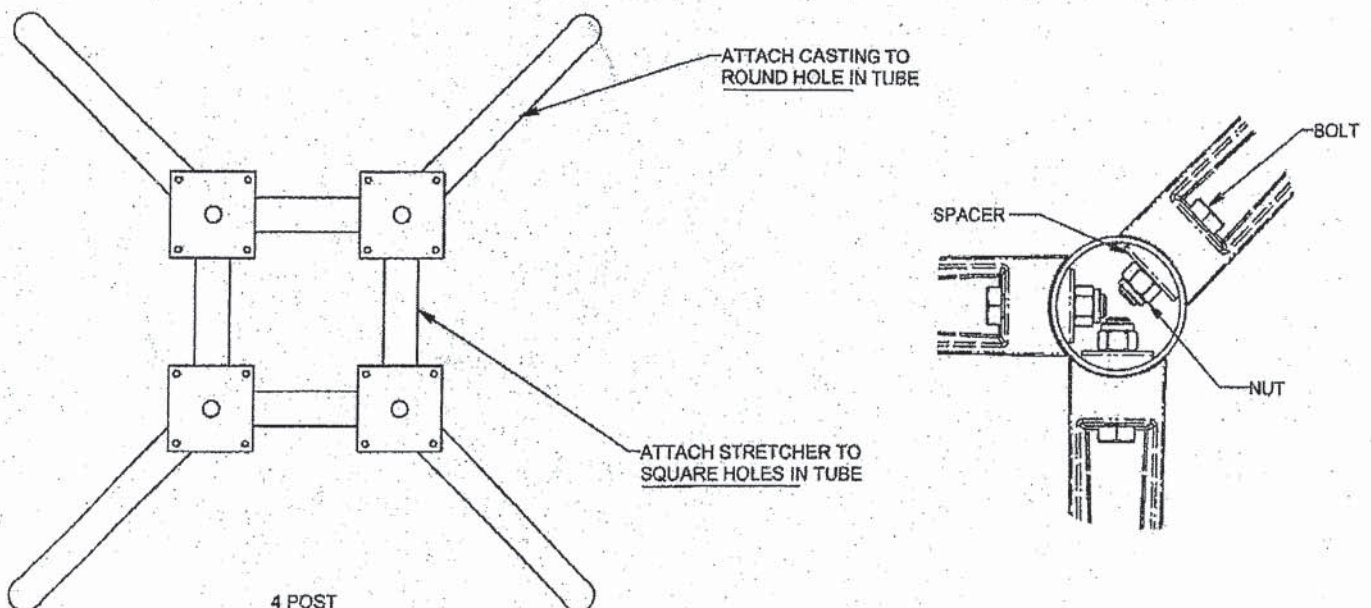
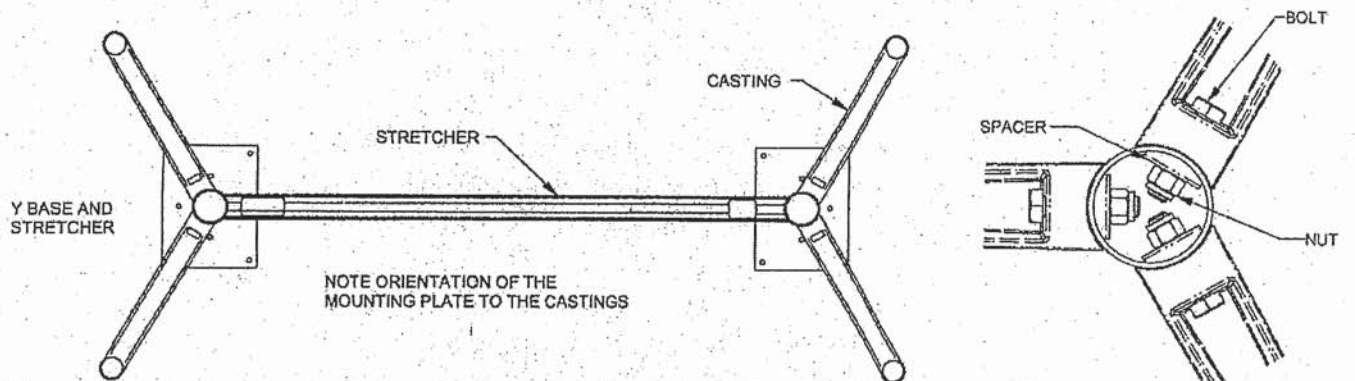

## Tables Flipping Up

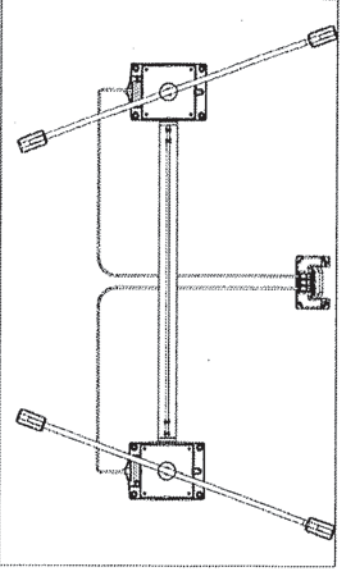
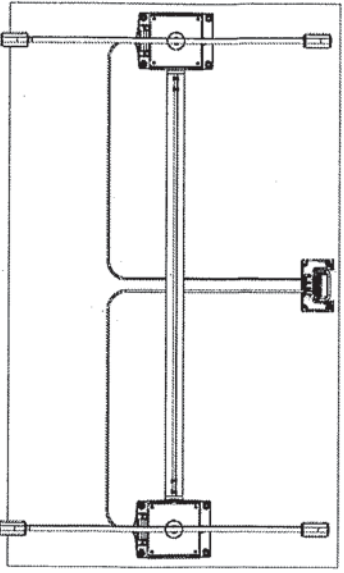
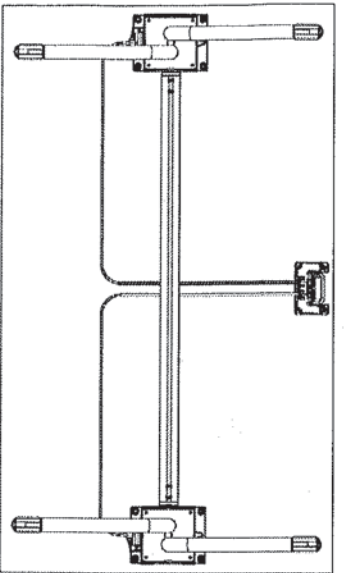

## Installation Instructions

### System Installation

1. Place work surface bottom side up on a non-marring surface.
2. Align holes on mounting plates with pre-drilled holes on bottom side of work surface. Fasten each mounting plate to work surface using the (4) four corner holes with #12 x 1" Phillips Pan Head screws.
3. Align holes on handle base with pre-drilled holes on bottom side of work surface. Fasten handle base to work surface with (4) four #12 x 1" Phillips Pan Head screws.
4. Position cable clips evenly along the cable and fasten to bottom side of work surface with #6 x 1/2" Phillips Pan Head screws.
5. Use handle assembly to release the mechanisms and lock the mechanisms in the upright position.
6. **Critical Step:** Complete installation of the system by fastening each mounting plate to work surface using the (4) four interior holes with #12 x 1" Phillips Pan Head screws.
7. Use handle assembly to release the mechanisms and return the mechanisms to lowered position.

### Leg Installation

1. Match orientation and position to enclosed diagram for each style of table leg and attach each leg with (4) four 1/4"-20 Pan Head Machine Screws.

\*Please note Leg Orientation as it relates to the position of the handle and each respective mechanism.

\*Optional Beam Shown

**\*FAILURE TO USE ALL SCREWS PROVIDED MAY VOID PRODUCT WARRANTY**

## Tables Flipping Down

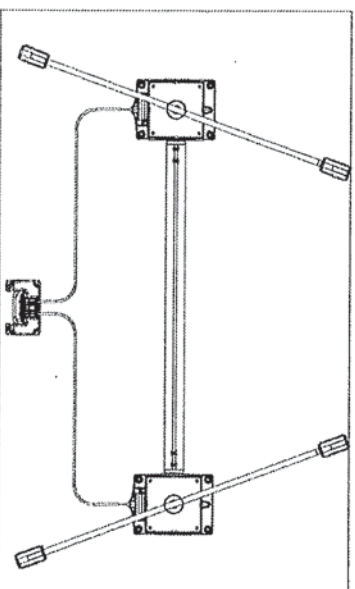
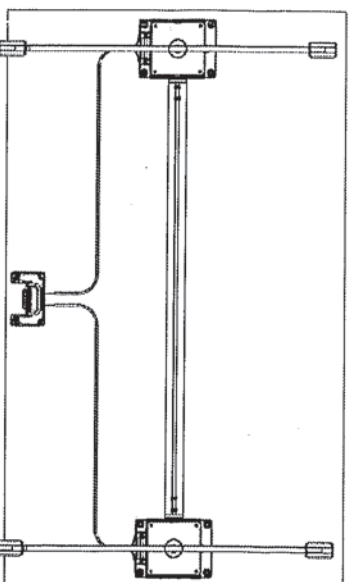
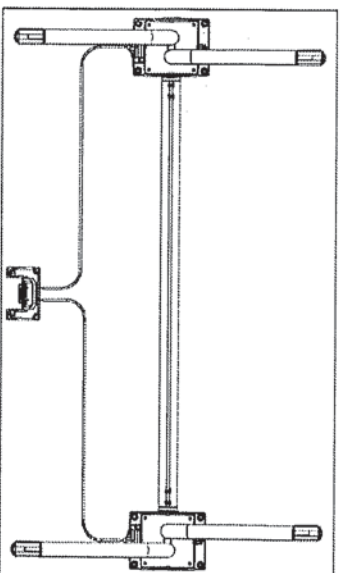

\*Please note Leg Orientation as it relates to the position of the handle and each respective mechanism.

\*Optional Beam Shown

## GENERAL NOTES

1. ALWAYS PROTECT THE WORKSURFACE DURING INSTALLATION.
2. ALWAYS LEVEL UNITS(S) AT FINAL LOCATION.

### 1 APPLY TAPE TO TAPE ROUT

- PULL PAPER OFF ONE SIDE OF DOUBLE STICK FOAM TAPE (H)
- ADHERE AROUND INSIDE PERIMETER OF FOAM ROUT
- REMOVE TAPE FROM TOP OF FOAM TAPE

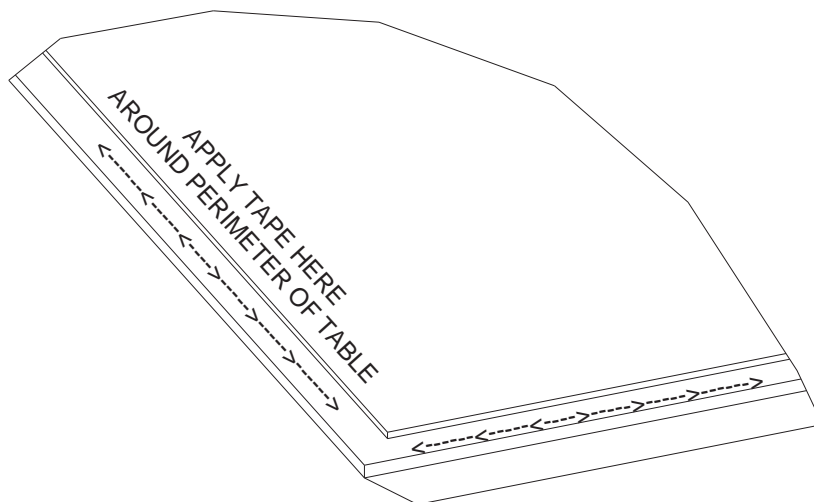
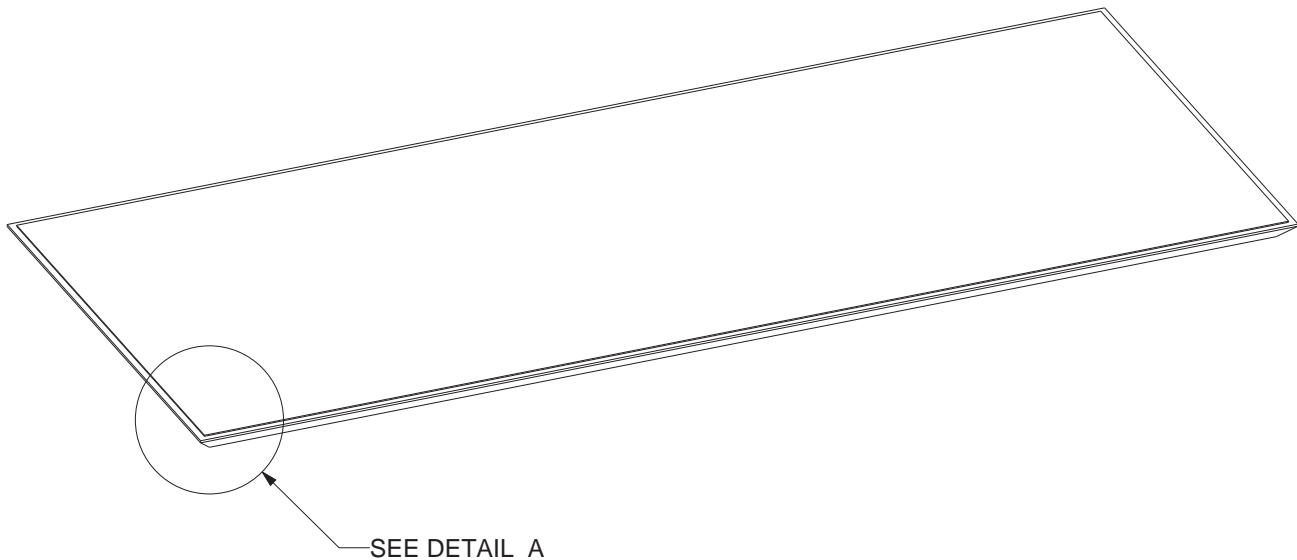



## GUNLOCKE

### GENERAL NOTES

1. ALWAYS PROTECT THE WHITEBOARD DURING INSTALLATION.
2. GUNLOCKE ASSUMES NO RESPONSIBILITY FOR THE FASTENERS USED TO ATTACH BRACKET(S) TO THE WALL. IT IS THE RESPONSIBILITY OF THE INSTALLER / END USER TO DETERMINE THE APPROPRIATE METHOD OF ATTACHMENT BASED ON THE TYPE OF WALL MATERIAL AND OR STUDS AVAILABLE.

### ATTACHMENT HARDWARE

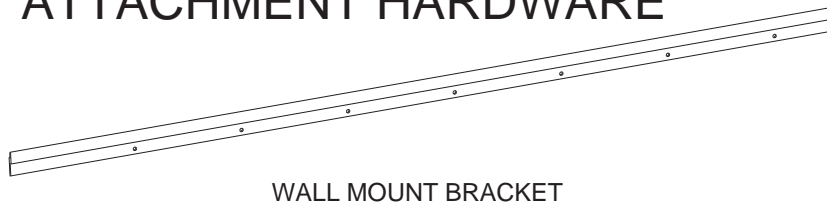

## 1 WHITEBOARD ATTACHMENT

- REMOVE BRACKET(S) FROM BACK OF WHITEBOARD
- DETERMINE THE DESIRED HEIGHT OF THE TOP OF THE WHITEBOARD
- MEASURE DOWN 3-13/32" FOR FIRST WALL MOUNT BRACKET AND MARK THE LOCATION
- IF MORE THAN ONE WALL MOUNT BRACKET IS USED, MEASURE DOWN USING SUPPLIED DIMENSIONS AND MARK THE LOCATIONS
- DIMENSIONS ARE TO CENTER OF HOLE ON WALL MOUNT BRACKETS
- CENTER WALL MOUNT BRACKETS WITH THE EVENTUAL CENTERLINE OF THE WHITEBOARD

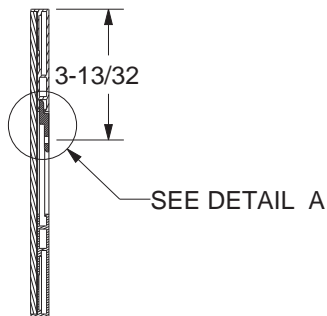

8" HEIGHT

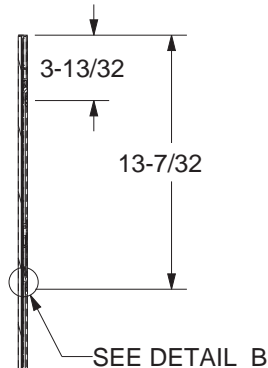

22" HEIGHT

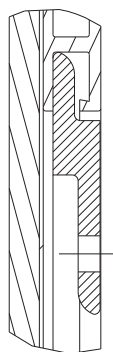

DETAIL A  
SCALE 1.000

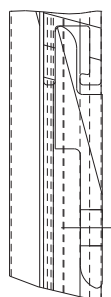

DETAIL B  
SCALE 1.000

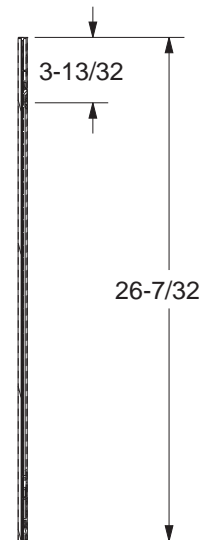

48" HEIGHT

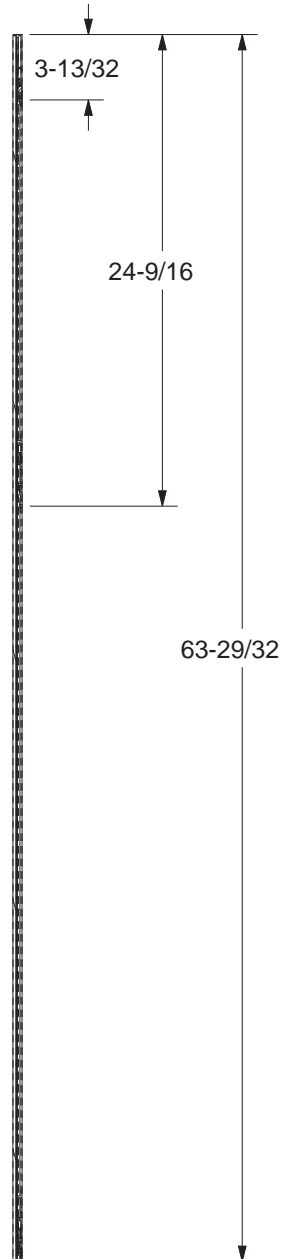

84" HEIGHT

# GENERAL NOTES

- 1. BASE AND TOP PLATE SHAPE MAY VARY
- 2. ALWAYS PROTECT THE TOP SURFACE

## ATTACHMENT HARDWARE

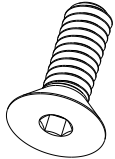

1/4-20 X 3/4  
SCH FLAT SCREW

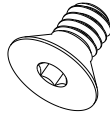

1/4-20 X 7/16 FH  
SOCKET HD SCREW

### 1 LAP TOP, END, & NESTING TABLE BASE ASSEMBLY

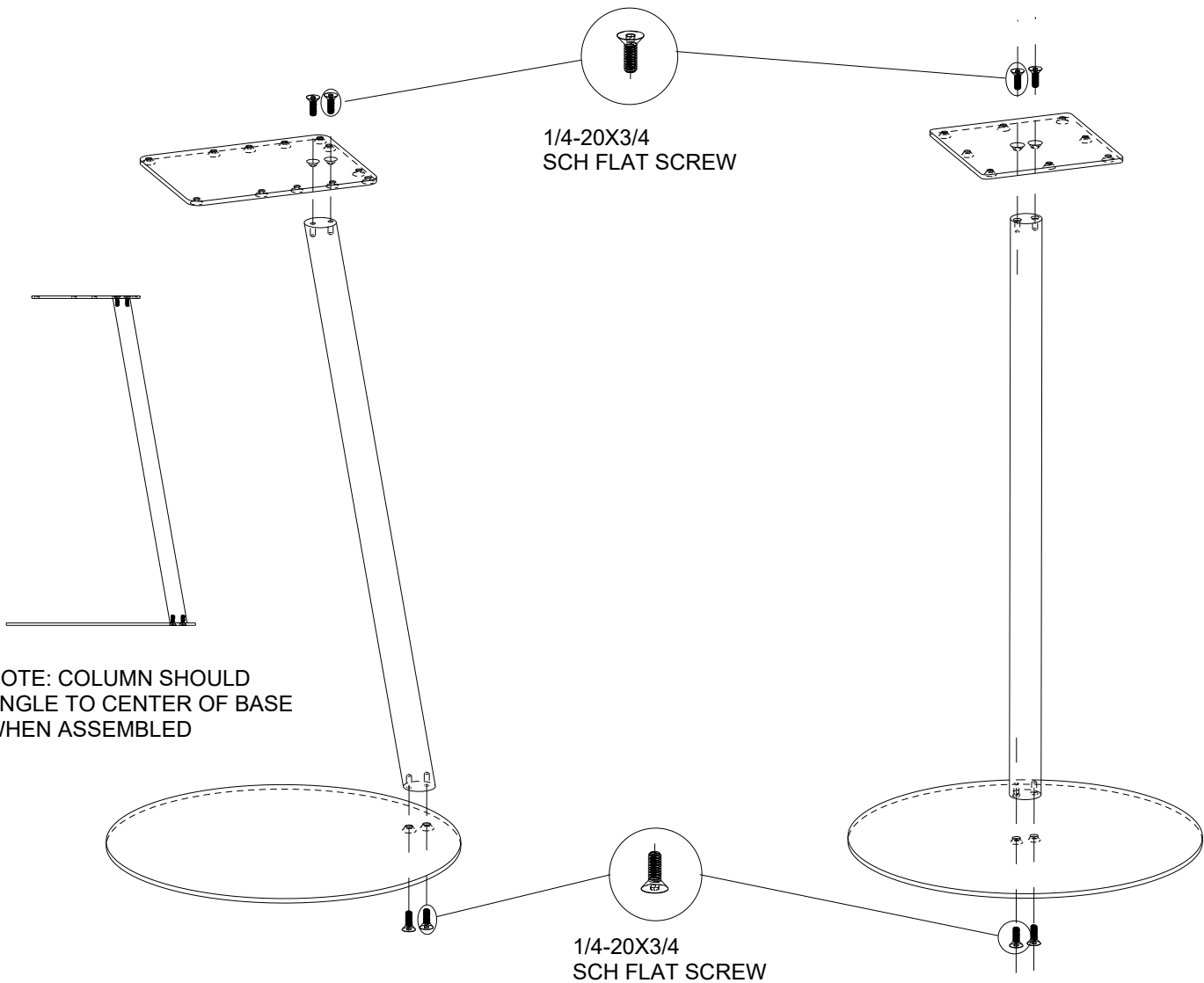



## 2 TOP ATTACHMENT

1. ALIGN INSERTS IN TOP TO BASE TOP PLATE  
USE 1/4-20 X 7/16 FH SOCKET HD SCREW TO ATTACH

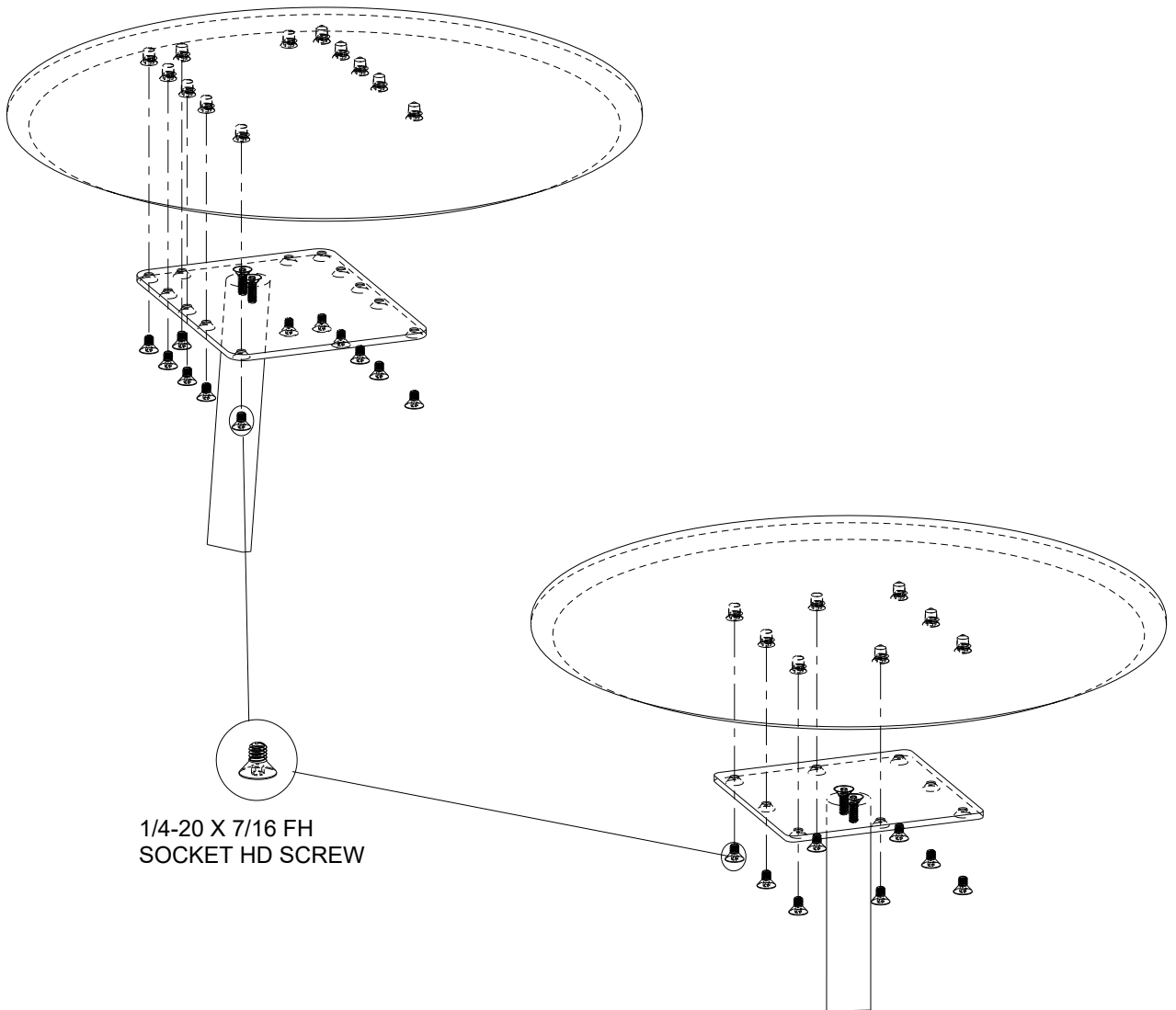

# GENERAL NOTES

- 1. BASE AND TOP PLATE SHAPE MAY VARY
- 2. ALWAYS PROTECT THE TOP SURFACE

## ATTACHMENT HARDWARE

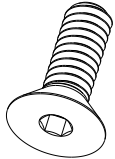

1/4-20 X 3/4  
SCH FLAT SCREW

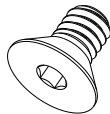

1/4-20 X 7/16  
FH SOCKET HD SCREW

### 1 LAP TOP, END, & NESTING TABLE BASE ASSEMBLY

- 1. USE 1/4-20 X 3/4 SCH FLAT SCREW TO ATTACH COLUMN

### 2 TOP ATTACHMENT

- 1. ALIGN INSERTS IN TOP TO BASE TOP PLATE  
USE 1/4-20 X 7/16 FH SOCKET HD SCREW TO ATTACH



1/4-20X3/4  
SCH FLAT SCREW

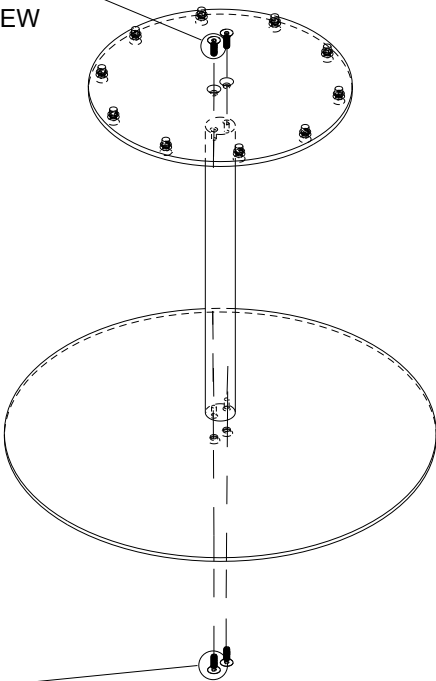

1/4-20X3/4  
SCH FLAT SCREW

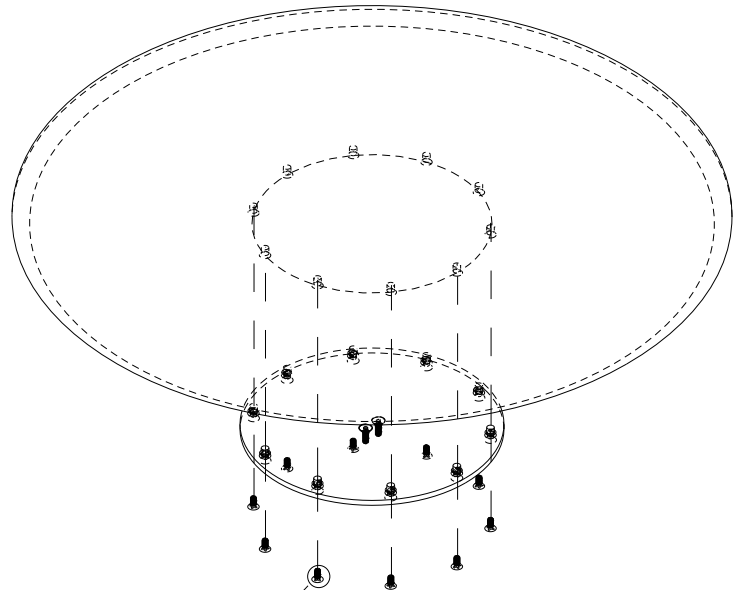

1/4-20 X 7/16  
FH SOCKET HD SCREW

## GENERAL NOTES

1. ALWAYS PROTECT THE WORKSURFACE DURING INSTALLATION.
2. ALWAYS LEVEL UNITS(S) AT FINAL LOCATION.

## ATTACHMENT HARDWARE



#8X1/2 PN PH  
WOOD SCREW

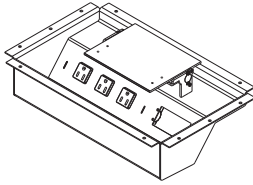

SINGLE PORT

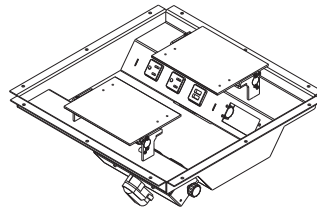

DOUBLE PORT

## 1 PORT ASSEMBLY

- ATTACH PORT ASSEMBLY TO UNDERSIDE OF WORKSURFACE OR SUBTOP
- CENTER IN CUTOUT
- SECURE USING #8X1/2 WOOD SCREWS

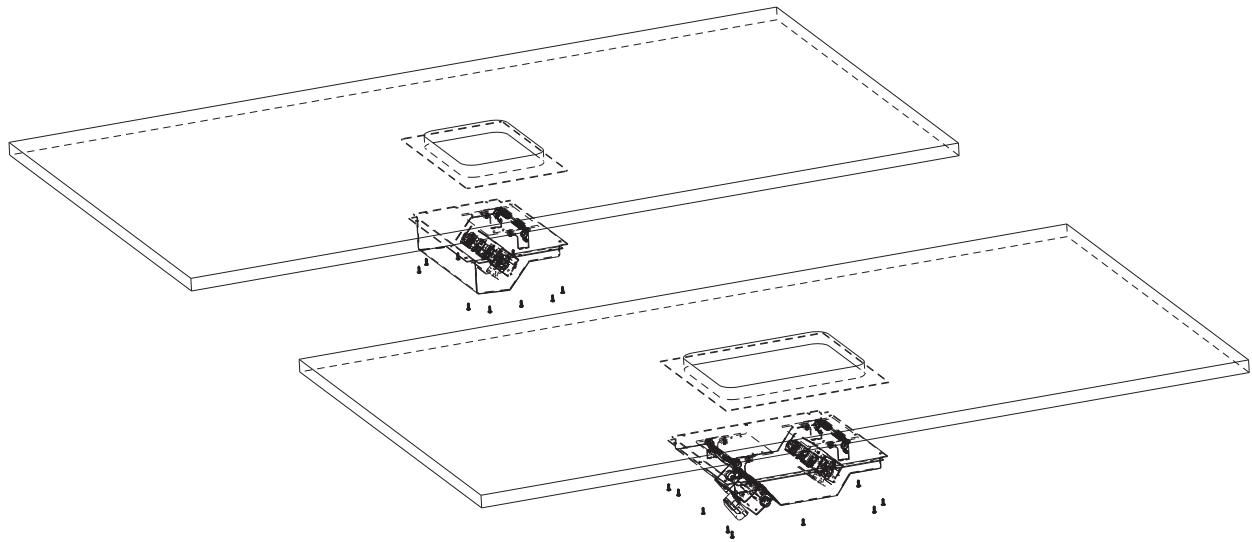

## GENERAL NOTES

1. ALWAYS PROTECT THE WORKSURFACE DURING INSTALLATION.
2. ALWAYS LEVEL UNITS(S) AT FINAL LOCATION.

## ATTACHMENT HARDWARE



#6-32 X 3/8 PN PH  
MACHINE SCREW

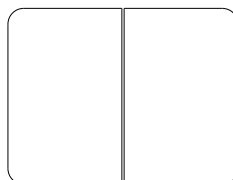

PORT DOOR  
DOUBLE



PORT DOOR  
SINGLE

## 1 ALUMINIUM PORT DOOR ASSEMBLY:

- PLACE SPACER BRACKET BETWEEN SUB-DOOR AND FINISHED DOOR
- SECURE USING #6-32 X 3/8 MACHINE SCREWS

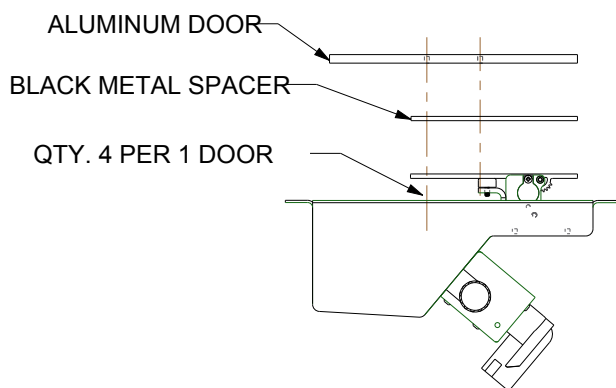

**\*ATTENTION\*\***  
BLACK METAL SPACER REQUIRED FOR ALUMINIUM DOOR INSTALLATION. FAILURE TO USE SPACER WILL CAUSE DAMAGE TO DOOR.

### NOTE, WHEN SECURING PORT DOORS:

- AFTER PORT DOOR(S) ARE ATTACHED THERE SHOULD BE A 3/8" GAP ON ALL SIDES
- WHEN ATTACHING PORT DOOR DOUBLE, THERE SHOULD BE A 1/8" GAP BETWEEN DOORS
- WHEN PORT DOORS ARE CLOSED THEY SHOULD BE LEVEL WITH THE WORKSURFACE
- IF NOT LEVEL, OPEN PORT DOOR(S) AND ADJUST RUBBER BUMPER WITH SCREW

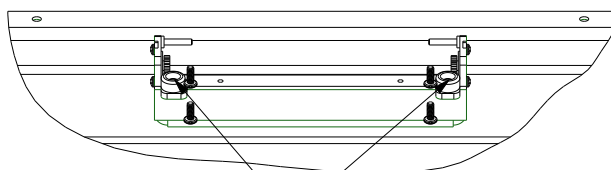

ADJUSTABLE RUBBER BUMPER  
WITH SCREW

## GENERAL NOTES

1. ALWAYS PROTECT THE WORKSURFACE DURING INSTALLATION.
2. ALWAYS LEVEL UNITS(S) AT FINAL LOCATION.

## ATTACHMENT HARDWARE



#6-32 X 5/16 PN PH  
MACHINE SCREW  
19917-4785-35

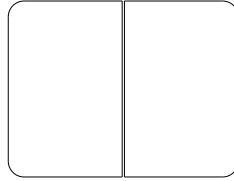

PORT DOOR  
DOUBLE

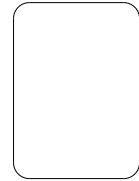

PORT DOOR  
SINGLE

## 2 VENEER PORT DOOR ASSEMBLY:

- ALIGN VENEER DOOR HOLES WITH THE SUB-DOOR SLOTS
- SECURE USING #6-32 X 5/16 MACHINE SCREWS

**\*\* NOTE \*\***

- WHEN ATTACHING WOOD VENEER DOORS, # ON BOTTOM OF DOOR WILL MATCH # ON BOTTOM OF WORKSURFACE
- ORIENT DOOR TO MATCH ORIENTATION OF #'S

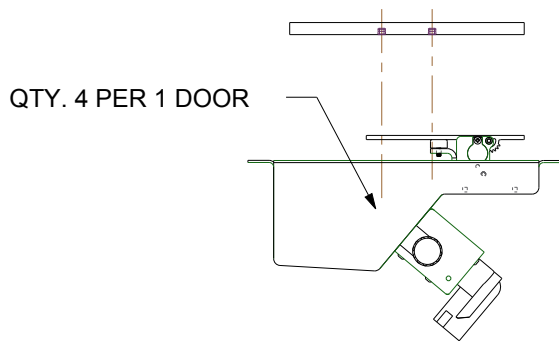

**NOTE, WHEN SECURING PORT DOORS:**

- AFTER PORT DOOR(S) ARE ATTACHED THERE SHOULD BE A 3/8" GAP ON ALL SIDES
- WHEN ATTACHING PORT DOOR DOUBLE, THERE SHOULD BE A 1/8" GAP BETWEEN DOORS
- WHEN PORT DOORS ARE CLOSED THEY SHOULD BE LEVEL WITH THE WORKSURFACE
- IF NOT LEVEL, OPEN PORT DOOR(S) AND ADJUST RUBBER BUMPER WITH SCREW

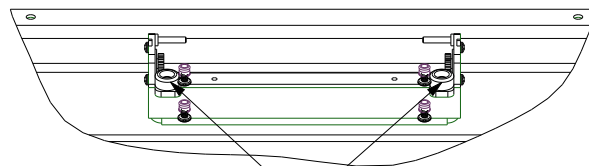

ADJUSTABLE RUBBER BUMPER  
WITH SCREW

# BYRNE

## INSTALLATION INSTRUCTIONS FOR ELLORA B

Install data jacks as described in the installation instructions provided with data adapters, BE01421

ElloraB		"X" Dim.
BE02511B	4 Windows	7-7/8"
BE02511B	5 Windows	9-3/8"
BE02511B	6 Windows	10-7/8"

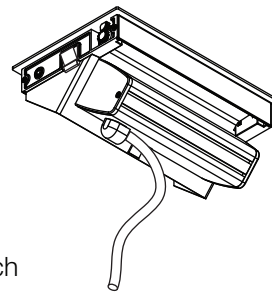
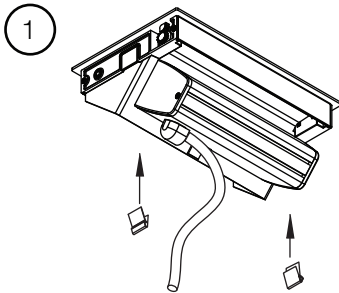
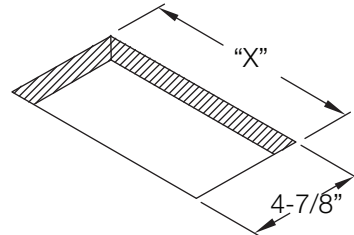

Attach 1 clips, at each end of unit base.

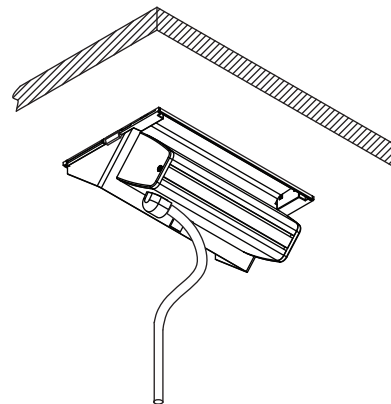
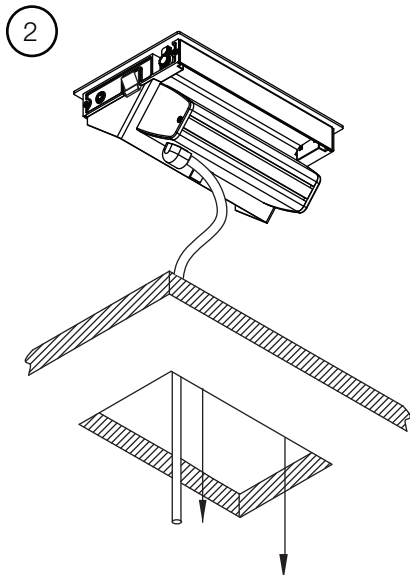

**Note:** In a conduit application, conduit should be supported according to local code. When managing conduit and cabling exiting the unit, ensure there is adequate slack to allow unit to open properly

**IMPORTANT:**  
Go to [www.extron.com](http://www.extron.com) for the complete user guide, installation instructions, and specifications.

# Cable Cubby 1200 and 1400 • Installation Guide

This guide provides instructions for an experienced installer to install and connect the Extron Cable Cubby 1200 and 1400.

The Cable Cubby units are furniture-mounted enclosures for cable access, connections, and AC power. Cables that are not in use can be stored out of the way while remaining connected to the presentation system.

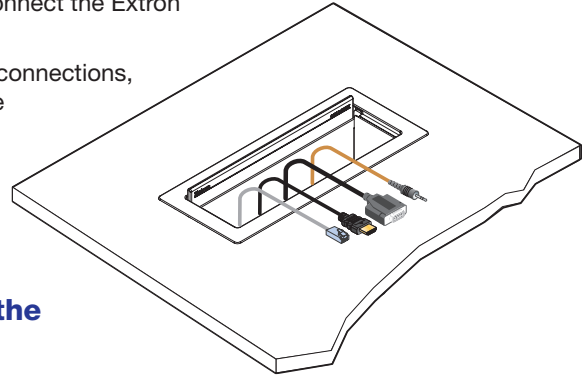

## Planning

### Check with local and state regulations before starting the installation

- Ensure that the planned installation complies with building and electrical codes.
- Ensure that the planned installation complies with the Americans with Disabilities Act or other accessibility requirements.

### Check all parts and equipment before installation

- Ensure that all parts are present in each kit.
- Ensure that necessary tools and equipment are available for the installation.



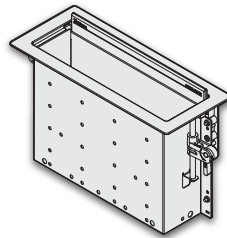



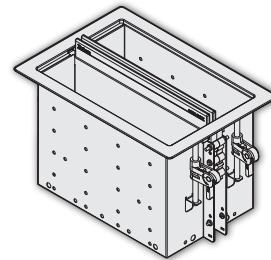

## Kit Contents

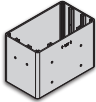

Cable Cubby 1200

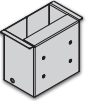
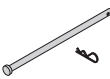

Cable Cubby 1400

Connectivity Bracket 	1	2
#4-40 Module Screws 	8	16
AAP Frame Plate 	1	2
Cable Grommet Plate 	1	2
"Show Me" Cable Trim Plate 	1	2
Hole Plugs 	6 (3/8"), 2 (1/4")	12 (3/8"), 4 (1/4")
Retractor Bracket 	1	2
Retractor Pin & Clip 	1	2
#6 Pan-head Mounting Screws and Star Washers 	8	16

# Cable Cubby 1200 and 1400 • Installation Guide (Continued)

## Preparing the Table

Cut a hole in the surface where the enclosure will be installed. Read the following information before making a cut.

### Determine the best location for the enclosure

- Ensure that the location where the Cable Cubby is to be installed is convenient for as many users as possible.
- Ensure that the edge on which the lid opens is oriented correctly.
- Ensure that there is ample space under the table for cables. Allow at least 36 inches of cable loop for each cable (see **Routing and Connecting Cables** on page 6).
- When installing Retractors in the Cable Cubby, ensure that there is enough space for the Retractor assembly under the table or furniture (see the *Cable Retractor Series/2 Installation Guide* for Retractor dimensions).

### Choose a method for cutting the hole in the table

**CAUTION:** Wear safety glasses when operating power equipment. Failure to comply can result in eye injury.

**ATTENTION :** Portez des lunettes de sécurité lorsque vous utilisez l'équipement électrique. Ne pas respecter cela peut conduire à une blessure à l'oeil.

**ATTENTION:** The opening in the table for the Cable Cubby should be cut only by licensed and bonded craftspeople. Exercise care to prevent scarring or damaging the furniture.

**ATTENTION :** L'ouverture dans la table pour le Cable Cubby devrait être coupée seulement par des artisans autorisés et qualifiés. Faites attention à ne pas faire de marques sur le meuble et à ne pas l'endommager.

Choose one of the following methods for cutting the hole:

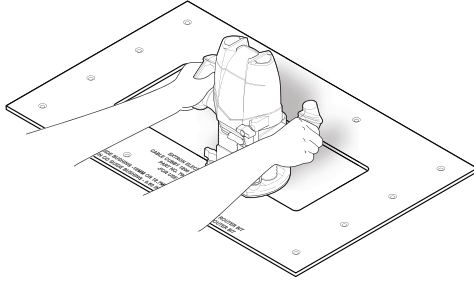
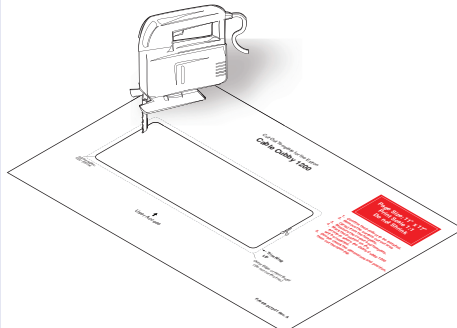
Hand Router and Routing Template	Jigsaw and Paper Cut-Out Template	CNC Wood Router											
		If using a CNC wood router or other precise machinery, use the exact cut-out dimensions for your model (see the table below).											
Visit <a href="http://www.extron.com">www.extron.com</a> for Cable Cubby routing template part numbers and instructions.	Dimensions and cut-out templates are available online at <a href="http://www.extron.com">www.extron.com</a> .	<table border="1"> <thead> <tr> <th rowspan="2">Product</th> <th colspan="2">Cut-out Dimensions</th> </tr> <tr> <th>User Access Width</th> <th>Side Dimension</th> </tr> </thead> <tbody> <tr> <td>CC 1200</td> <td>10.00" (254.0 mm)</td> <td>4.00" (101.6 mm)</td> </tr> <tr> <td>CC 1400</td> <td>10.00" (254.0 mm)</td> <td>6.75" (171.5 mm)</td> </tr> </tbody> </table>	Product	Cut-out Dimensions		User Access Width	Side Dimension	CC 1200	10.00" (254.0 mm)	4.00" (101.6 mm)	CC 1400	10.00" (254.0 mm)	6.75" (171.5 mm)
		Product		Cut-out Dimensions									
			User Access Width	Side Dimension									
CC 1200	10.00" (254.0 mm)	4.00" (101.6 mm)											
CC 1400	10.00" (254.0 mm)	6.75" (171.5 mm)											

## Preparing the Cable Cubby

### Step 1 – Assemble Connectivity Modules

Connectivity modules allow you to populate the Cable Cubby enclosure with a combination of AAPs, cable pass-through, or Retractors. Follow the steps below to assemble the connectivity modules of your choice.

#### Option 1: AAP Module

- 1** Secure up to three single-space AAPs in the AAP plate.

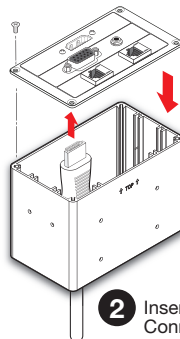

- 3** Secure the AAP plate on the connectivity brackets, using four of the provided module screws.

- 2** Insert cables through the bottom of the connectivity bracket. Connect cables to the AAPs.

**NOTE:** After assembling the module, proceed to **Step 2 – Install the Modules** on page 4.



## Option 2: Cable Pass-Through Module

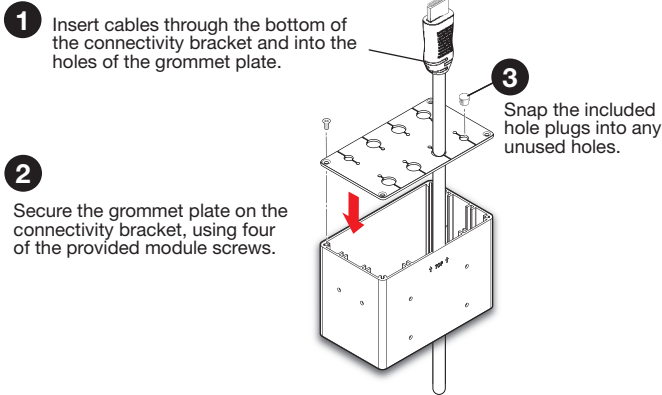

## For “Show Me” Cables:

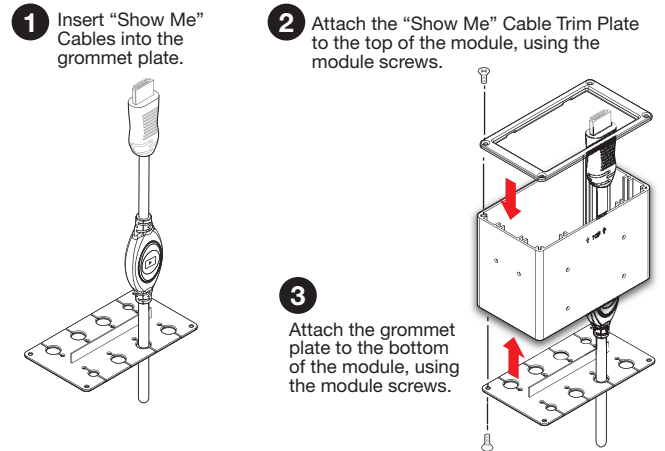

**NOTE:** After assembling the module, proceed to **Step 2 – Install the Modules** on the next page.

## Option 3: Retractor Bracket

Use the Retractor Bracket to mount Retractors in the Cable Cubby enclosure. There are two options for installing the bracket (Options 3a and 3b, below).

**NOTE:** If installing more than one bracket in the Cable Cubby 1400, see **Retractor Configuration for Cable Cubby 1400** on page 6.

### Option 3a

Use this option for the Cable Cubby 1200, and for vertical or angular Retractor mounting in a Cable Cubby 1400.

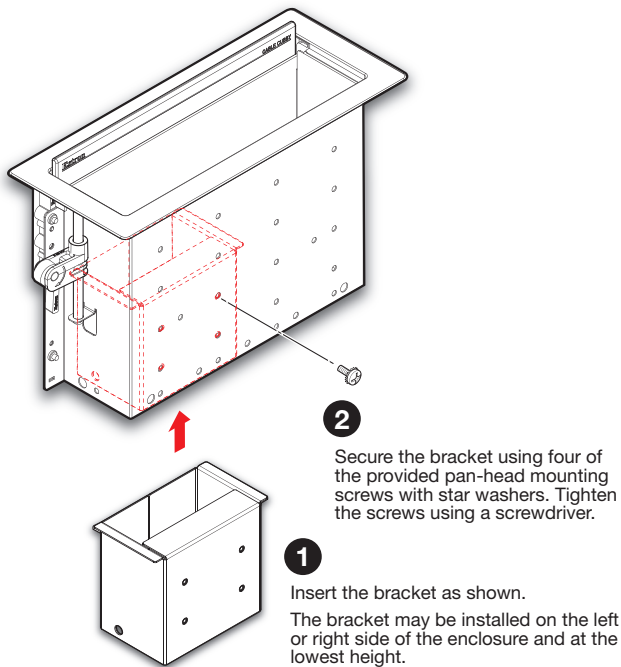

### Option 3b

Use this option for horizontal Retractor mounting in a Cable Cubby 1400 only.

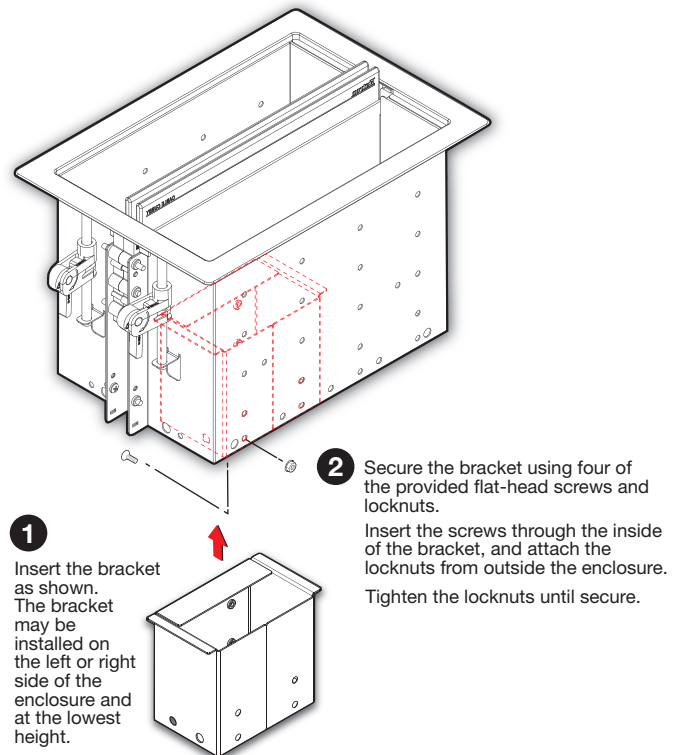

## NOTES:

- After installing the bracket, proceed to **Step 2 – Install the Modules** on the next page to install the power module.
- After mounting the Cable Cubby on the table, install the Retractors (see **Installing Retractors** on page 5).

## Step 2 – Install the Modules

Determine where the connectivity modules and power module will be installed in the Cable Cubby. The modules may be installed on the left or right side of the enclosure and at various heights.

### NOTES:

- Ensure that there is enough room above the modules for the Cable Cubby lid to close completely.
- Use a screwdriver to secure the modules with the screws.

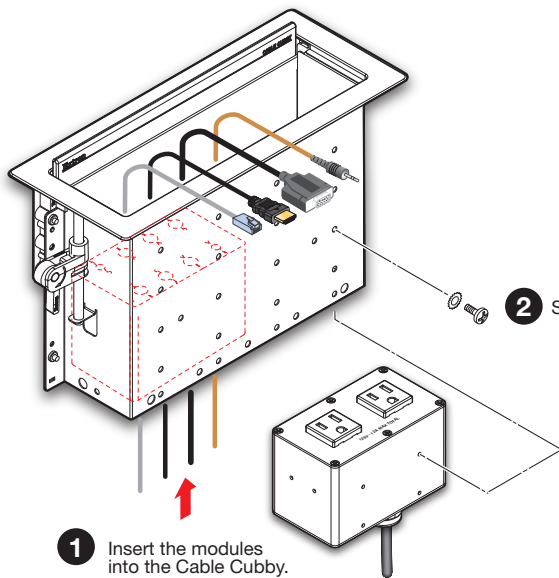

**WARNING: Risk of Electric Shock.** To ensure proper electrical grounding, use the provided #6-32 mounting screws with the star washers.

**AVERTISSEMENT : Risque de choc électrique.** Afin d'assurer une mise à la terre correcte, utilisez les fixations de mise à la terre #6-32 et les rondelles en étoile fournies.

## Mounting the Cable Cubby in the Table

### Step 1 – Mount the Cable Cubby flush with the table

**CAUTION:** The flanged edges of the top of the surface enclosure are sharp. These edges are also soft and may be easily nicked or bent. Exercise caution when handling the enclosure to prevent personal injury or damage to the enclosure.

**ATTENTION :** Les extrémités à brides du haut de la surface du boîtier sont aiguisées. Ces extrémités sont aussi lisses et peuvent facilement être coupées ou pliées. Soyez prudents lorsque vous manipulez le boîtier afin d'éviter de l'endommager ou de vous blesser.

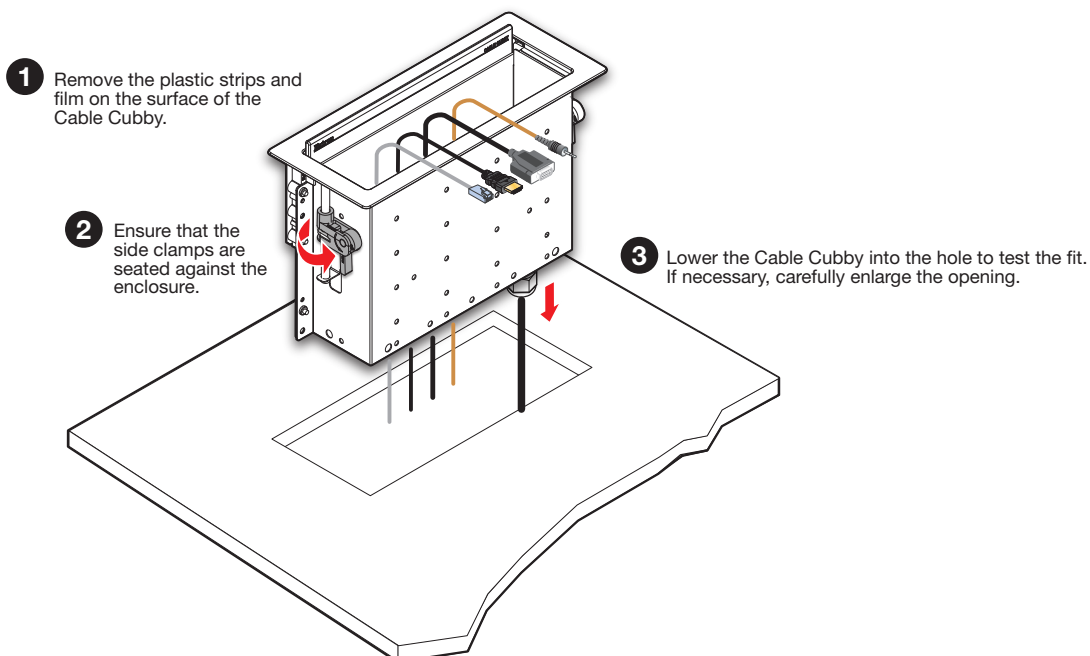

# Cable Cubby 1200 and 1400 • Installation Guide (Continued)

## Step 2 – Under the table, adjust the side clamps on the enclosure

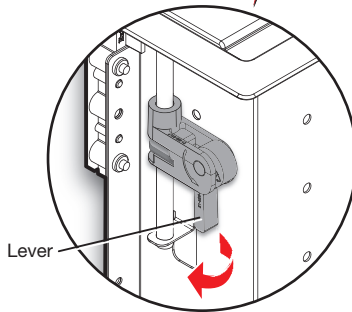
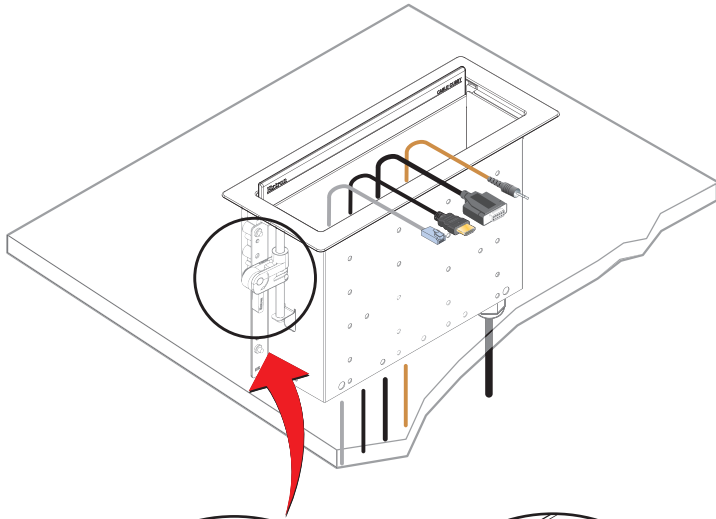

**1** Rotate the side clamp outward and ensure that the lever is down.

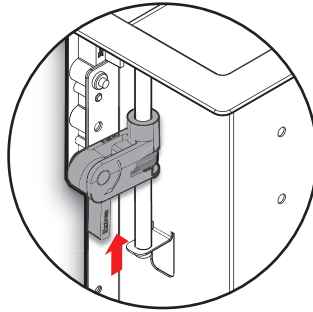

**2** Slide the clamp all the way up against the bottom of the table.

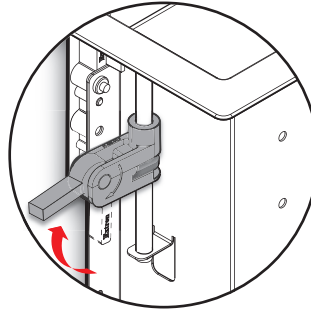

**3** Ensure the Cable Cubby is firmly seated in the table. Raise the lever to secure the Cable Cubby.

**NOTE:** To lower the side clamp, turn the lever down, then press and hold the locking plate while sliding down the clamp.

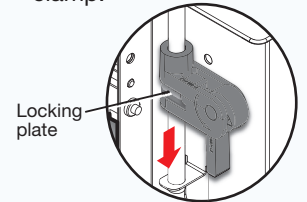

## Installing Retractors

Follow the steps below to install Retractors. For horizontal or angular Retractor mounting, see the information at right, then follow the steps below.

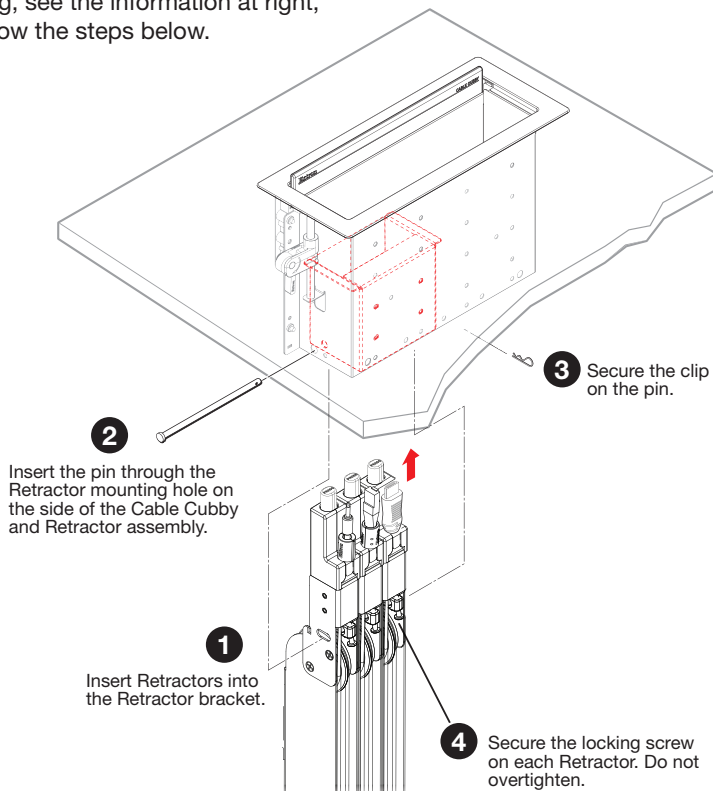

### Horizontal Mounting

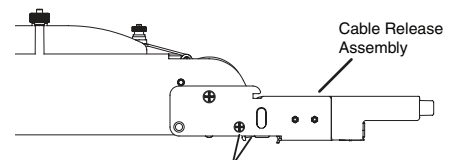

Remove two enclosure screws (one on each side) from this position. Then, mount the Retractors as shown at left.

See the *Cable Retractor Setup Guide*, available on the Extron website, for additional steps.

### Angular Mounting

Remove the enclosure screws as shown above, then follow this step:

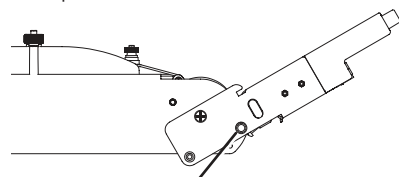

Move the cable release assembly upward until the angular mounting hole is visible. Reinstall the enclosure screws in this hole (both sides).

## Retractor Configuration for Cable Cubby 1400

### Vertical or angular mounting:

The included brackets must be installed diagonally in the enclosures as shown at right.

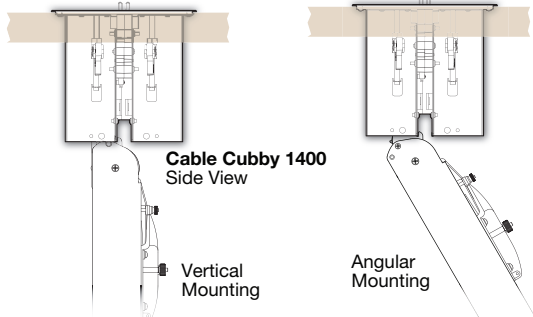

### Horizontal mounting:

Install the brackets as shown at right.

**NOTE:** Retractors may also be mounted using the Quad Bracket (see [www.extron.com](http://www.extron.com) for part numbers).

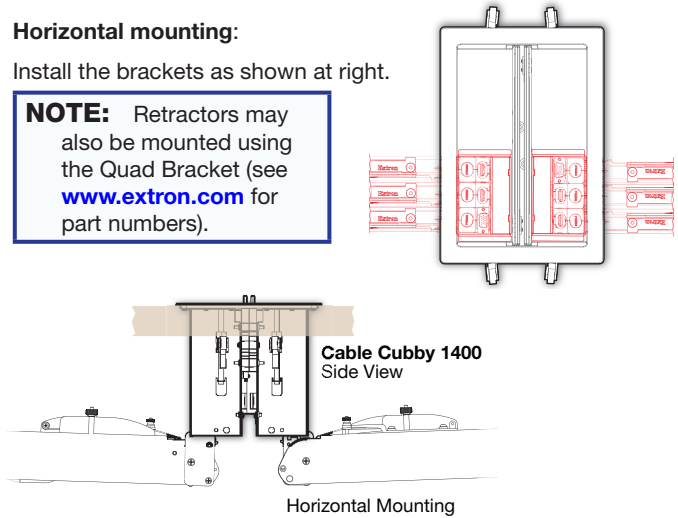

## Routing and Connecting Cables

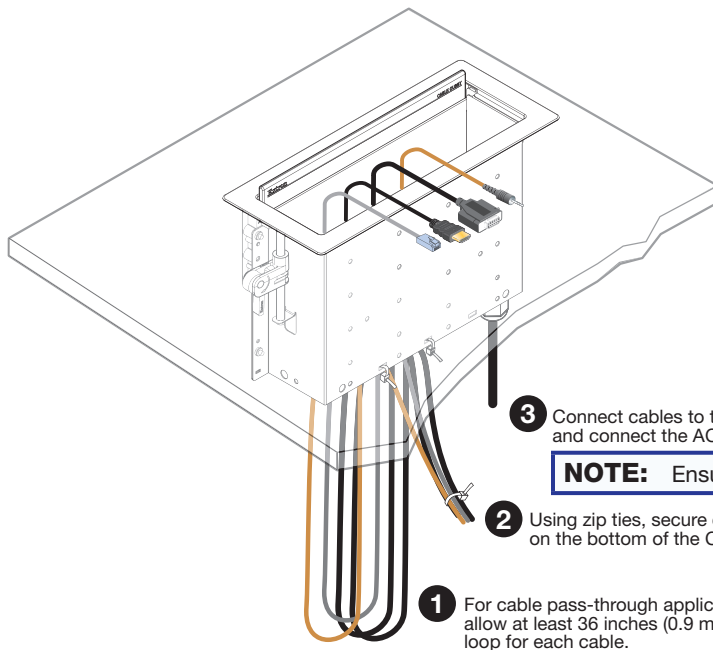

### CAUTION:

**Risk of Electric Shock.**

This equipment must be grounded.

### ATTENTION :

**Risque de choc électrique.**

Cet équipement doit être fixé au sol.

**NOTE:** Ensure that there is no tension on the power cable.

## Installation Checklist

### Planning (page 1)

- Check with local and state regulations before starting the installation
- Check all parts and equipment before installation

### Preparing the Table (page 2)

- Determine the best location for the enclosure
- Choose a method for cutting the hole in the table

### Preparing the Cable Cubby (page 3)

- Assemble Connectivity Modules
- Install the Modules (page 4)

### Mounting the Cable Cubby in the Table (page 4)

- Mount the Cable Cubby flush with the table

### Installing Retractors (page 5)

### Routing and Connecting Cables (page 6)

**STU  
DIO**

BY DEKKO 2505 Dekko Drive  
Garrett, IN 46738  
Customer Service: 800.357.5622

# ASHLEY DUO

- Corded -  
Above Worksurface Mounting  
Installation Instruction

This device complies with part 15A of the FCC Rules. Operation is subject to the following two conditions: (1) This device may not cause harmful interference, and (2) this device must accept any interference received, including interference that may cause undesired operation.

## Tools Required

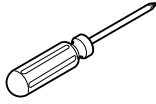

Screwdriver needed for optional power cord mounting clamps.

### 1 Slide Bracket Behind Worksurface

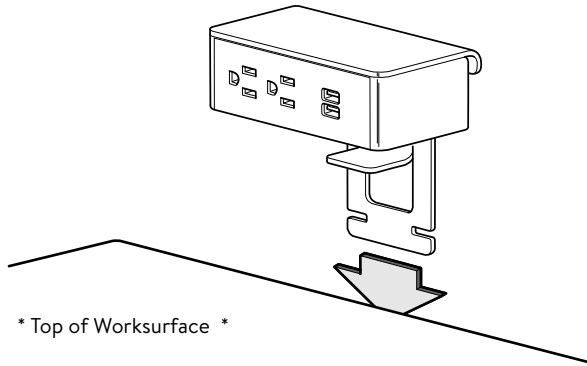

\* Top of Worksurface \*

### 2 Install Bottom Bracket Under the Worksurface

\* Underside of Worksurface \*

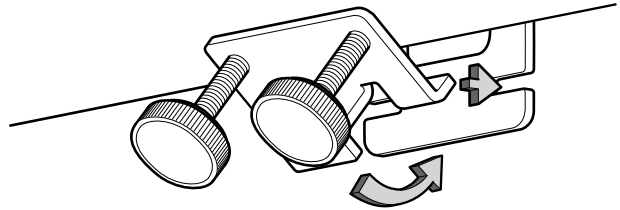

### 3 Secure Thumb Screws and Route Power Cord Option to Nearest Power Distribution Source

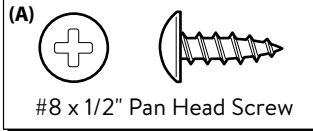

\* Underside of Worksurface \*

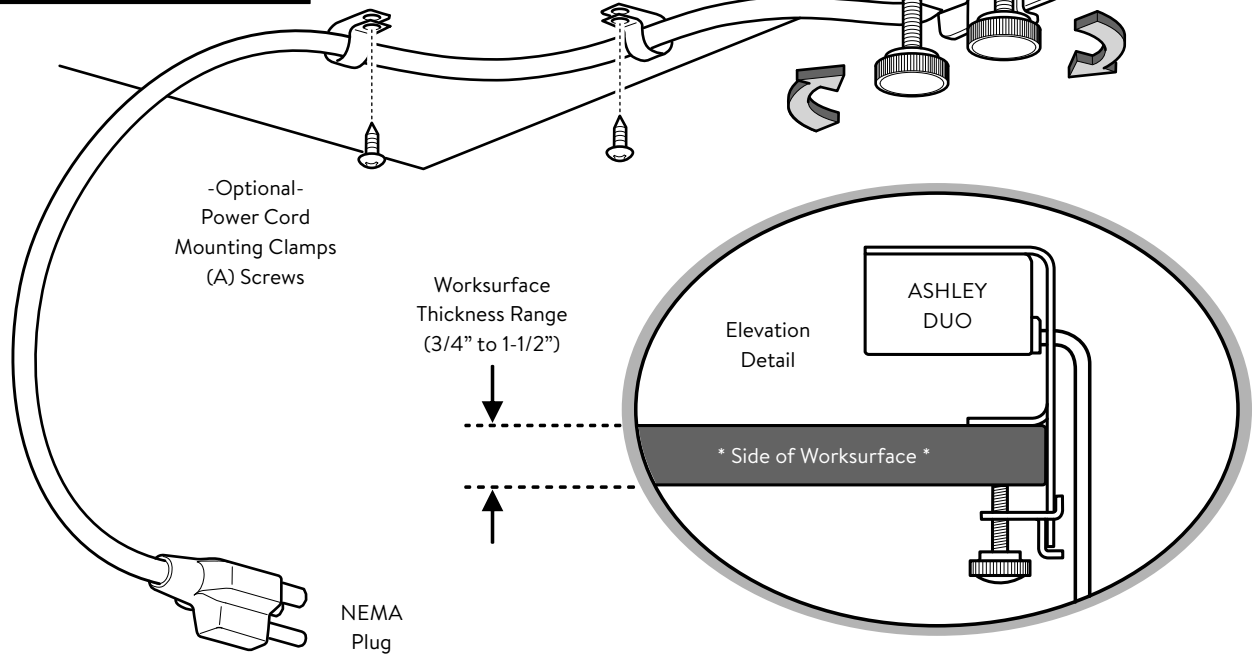

-Optional-  
Power Cord  
Mounting Clamps  
(A) Screws

Worksurface  
Thickness Range  
(3/4" to 1-1/2")

ASHLEY  
DUO  
Elevation  
Detail

\* Side of Worksurface \*

NEMA  
Plug



BY DEKKO

2505 Dekko Drive  
Garrett, IN 46738  
Customer Service: 800.357.5622

# ASHLEY DUO BEZEL

- Corded -

Horizontal & Vertical Surface Mounting  
Installation Instruction

This device complies with part 15A of the FCC Rules. Operation is subject to the following two conditions: (1) This device may not cause harmful interference, and (2) this device must accept any interference received, including interference that may cause undesired operation.

### Tools Required

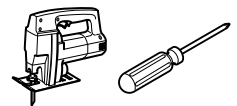

## 1 Cutout Opening for Ashley Duo Bezel Assembly

### \* NOTE \*

Max Radius on Cutout Corners is 1/4"

Thickness Range of Mounting Surface (3/4" to 1-1/2")

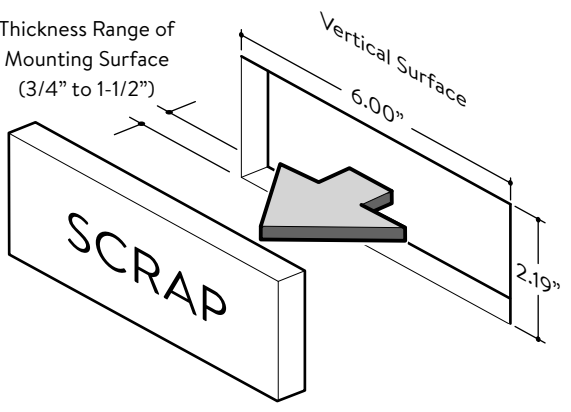

## 2 Install Ashley Duo Bezel Assembly into Cutout

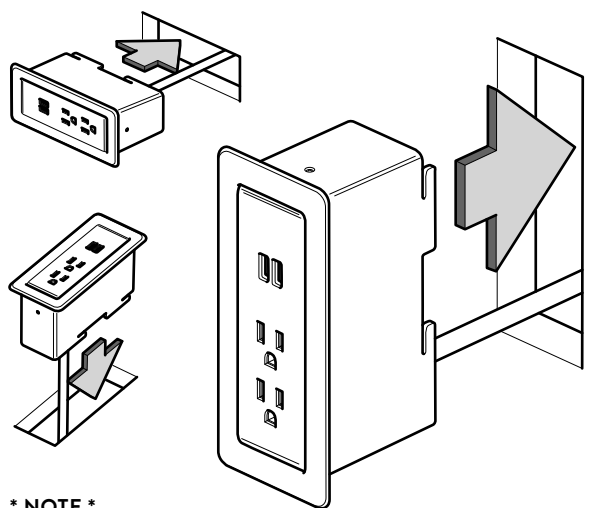

### \* NOTE \*

Tabs Point Up when Unit is Installed Vertically - See Vertical Orientation

## 3 Install Retainer Bracket

Vertical Surface Back Side

\* Align Tabs on Bezel with Slots on Retainer Bracket and Slide into Position \*

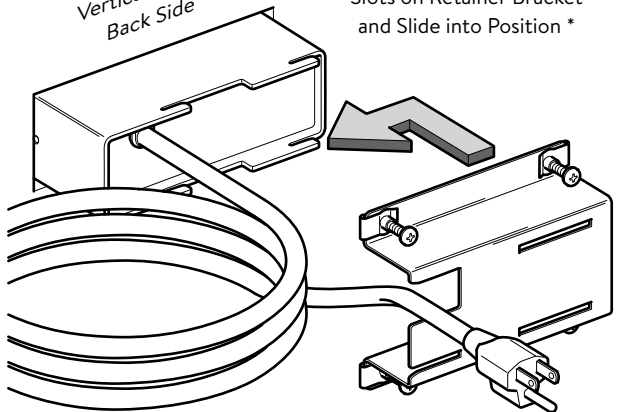

### \* NOTE \*

Route Power Cord Through Notch in Retainer Bracket

## 4 Route Power Cord to Nearest Power Distribution Source

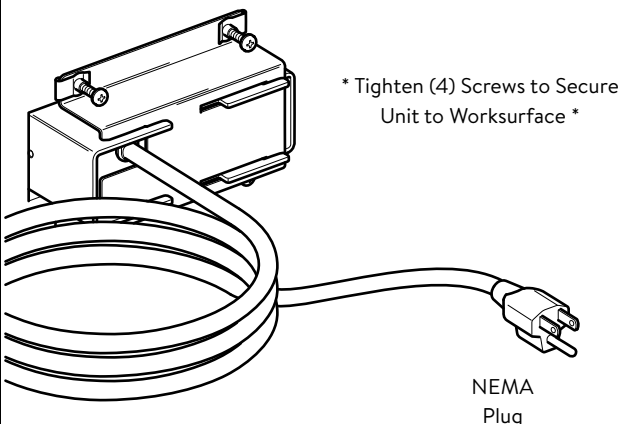

\* Tighten (4) Screws to Secure Unit to Worksurface \*

NEMA Plug

STU  
DIO

BY DEKKO

2505 Dekko Drive  
Garrett, IN 46738  
Customer Service: 800.357.5622

# ASHLEY DUO UNDER

- Corded -

Under Worksurface Mounting

Installation Instruction

This device complies with part 15A of the FCC Rules. Operation is subject to the following two conditions: (1) This device may not cause harmful interference, and (2) this device must accept any interference received, including interference that may cause undesired operation.

## Tools Required

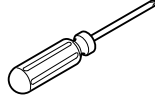
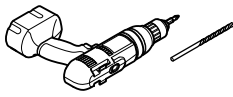

Screwdriver needed for optional power cord mounting clamps.

### 1 Place Template and Pre-Drill Holes

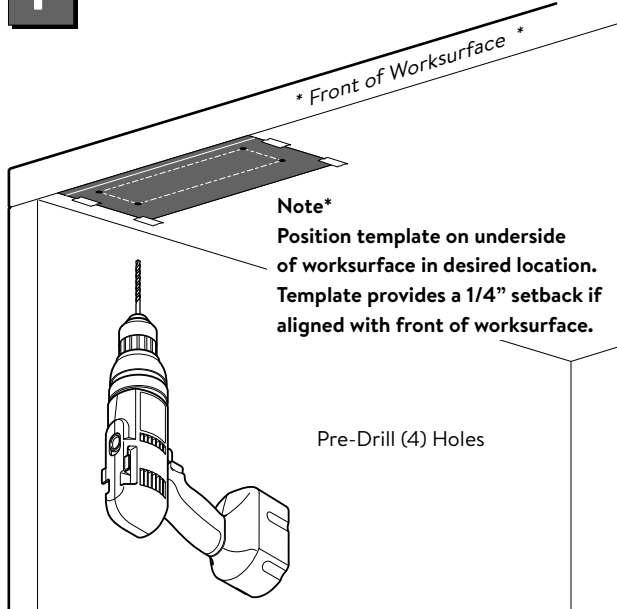

### 2 Install Ashley Duo Under to Worksurface

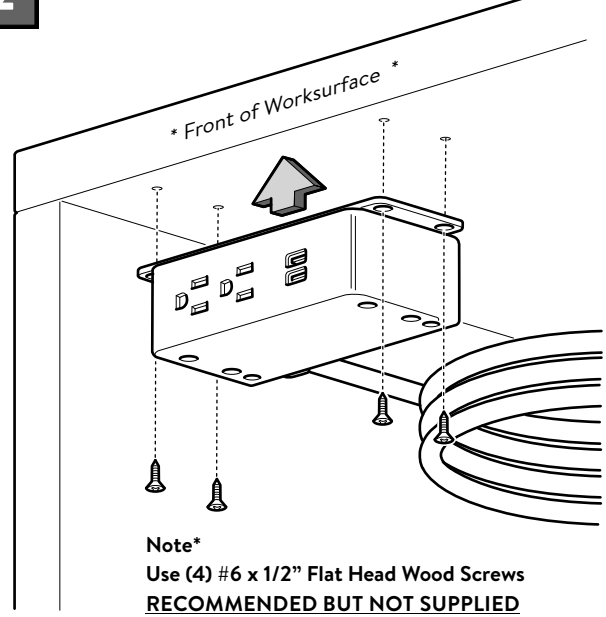

### 3 Route Power Cord Option to Nearest Power Distribution Source

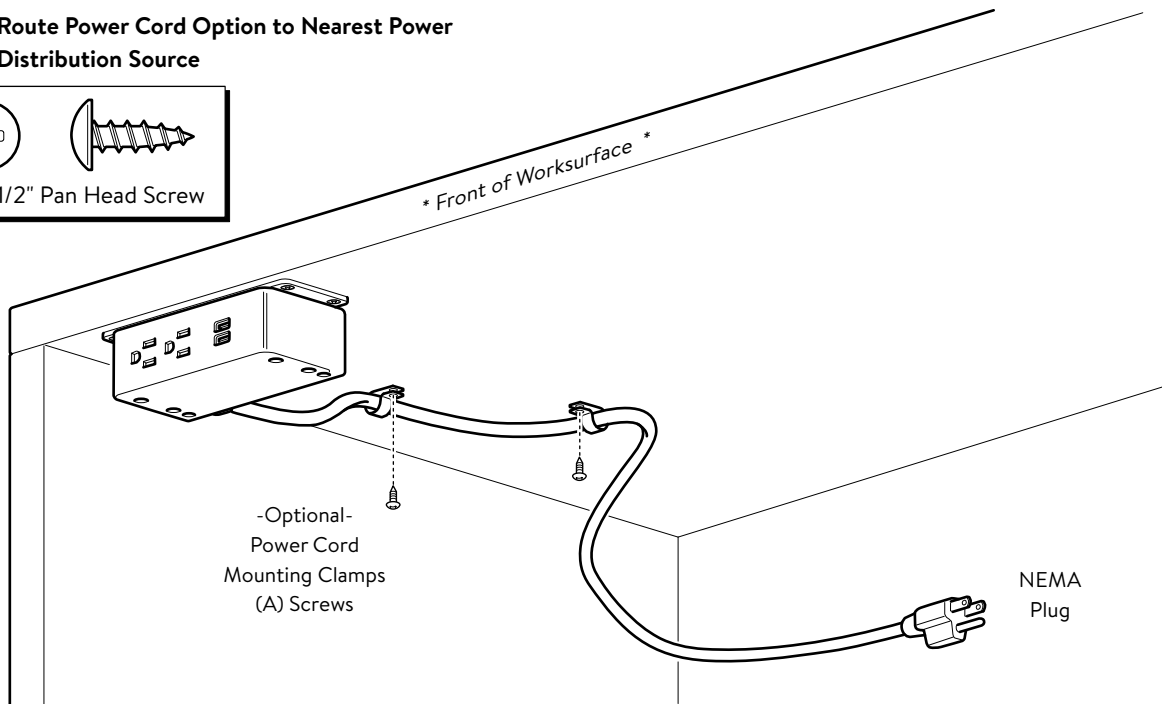
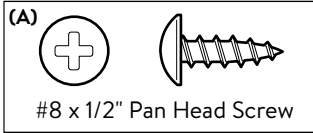

E.C.N. No: GD17-002964

Part Number: G110052

Page Number: 1 of 2

Revision: E

## GUNLOCKE

## GENERAL NOTES

1. ALWAYS PROTECT THE WORKSURFACE DURING INSTALLATION.
2. ALWAYS LEVEL UNITS(S) AT FINAL LOCATION.

### ATTACH LEG

USE THESE PILOT HOLES FOR LEG ALIGNMENT.

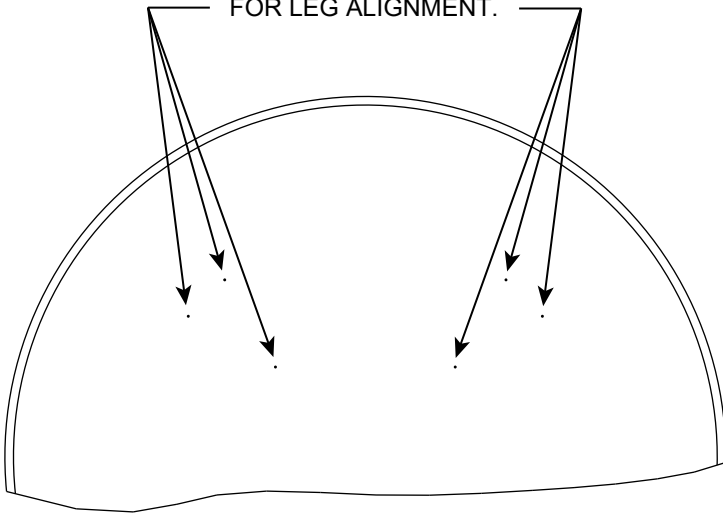

USE THESE PILOT HOLES FOR LEG ALIGNMENT.

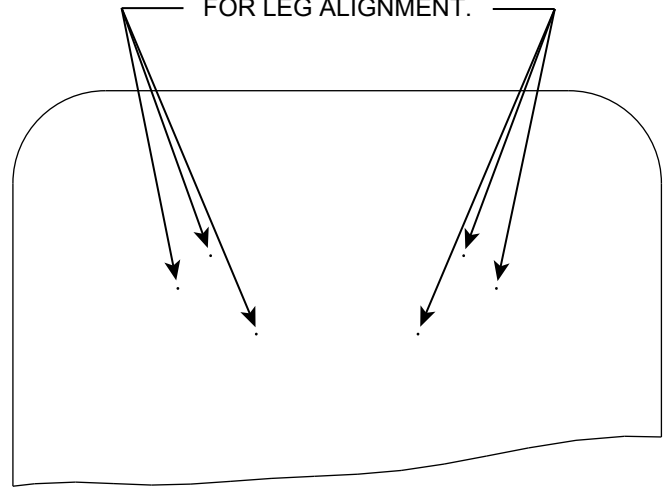

ALIGN THESE LEG SCREW HOLES WITH THE NOTED PILOT HOLES.

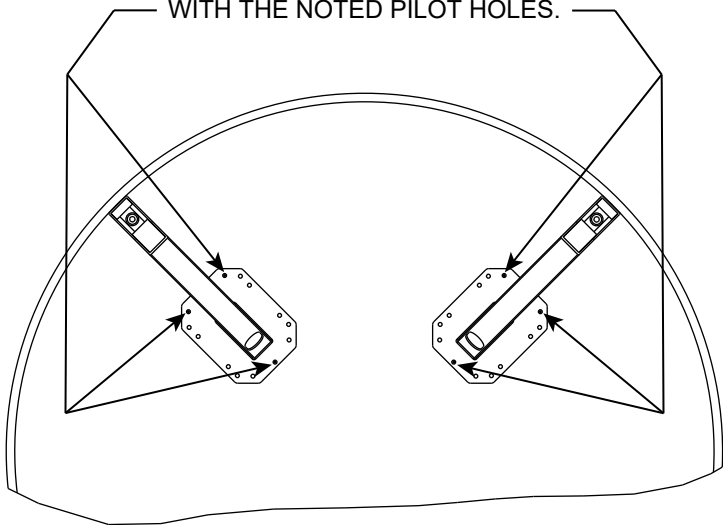

ALIGN THESE LEG SCREW HOLES WITH THE NOTED PILOT HOLES.

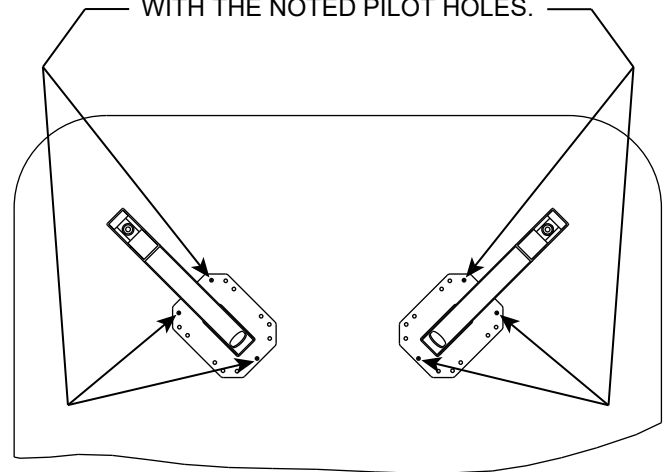



## GUNLOCKE

## GENERAL NOTES

1. ALWAYS PROTECT THE WORKSURFACE DURING INSTALLATION.
2. ALWAYS LEVEL UNITS(S) AT FINAL LOCATION.

### ATTACH LEG

- 1 ATTACH LEG ASSEMBLY WITH SCREWS USING A PHILLIPS HEAD DRIVER.  
USE THREE SCREWS PER LEG ASSEMBLY.

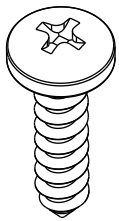

**X 3** PER LEG

#10 1" SCREWS

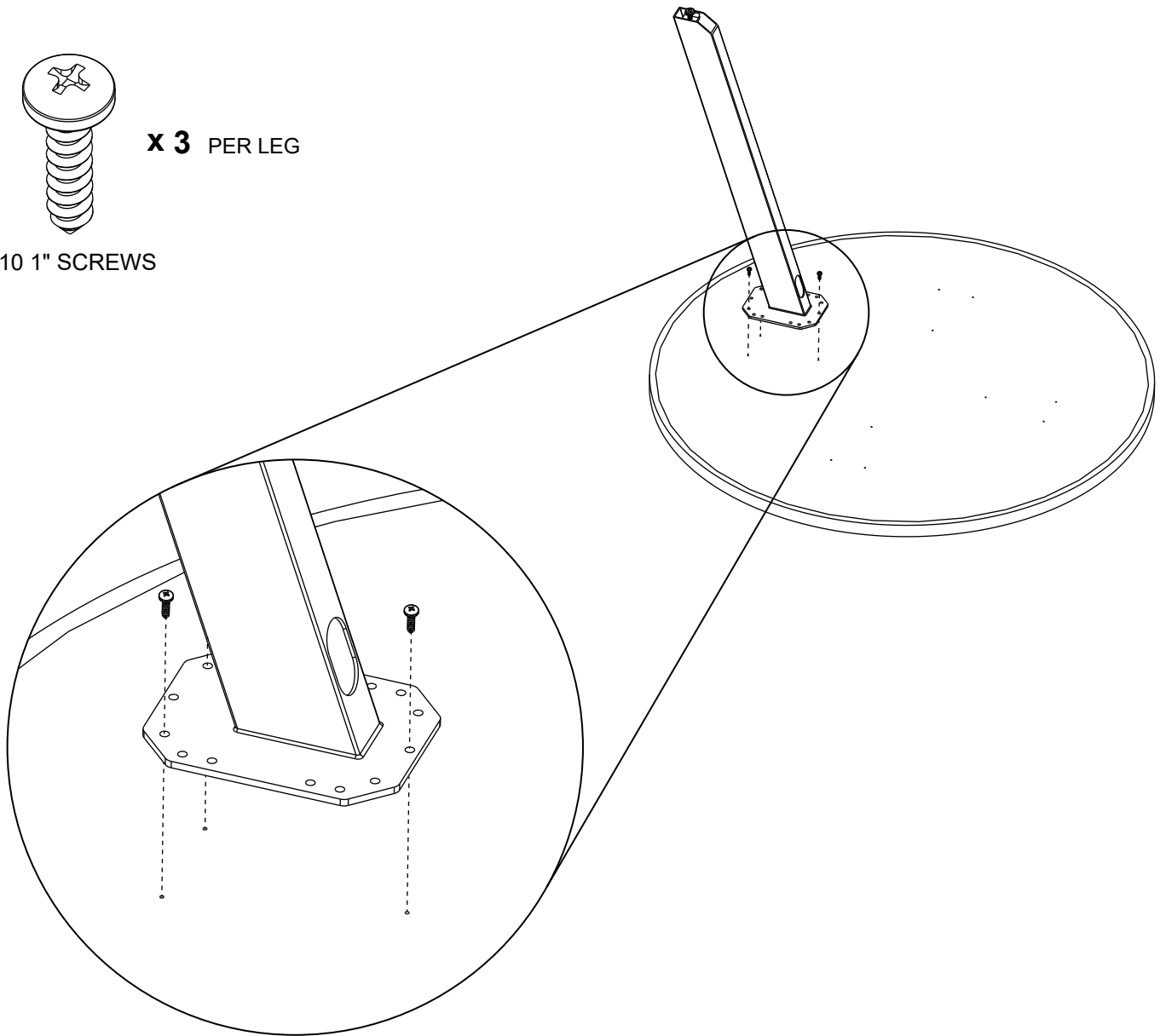

**IMPORTANT:** INSTALL STIFFENERS TO WORKSURFACE BEFORE FLIPPING UPRIGHT (SEE PAGE 3). TO AVOID DAMAGE TO THE PRODUCT, DO NOT PIVOT TABLE UPRIGHT WITH WEIGHT ON THE LEGS. INSTEAD, LIFT TABLE WHILE TURNING AND SET DOWN ONCE TABLE IS IN THE CORRECT ORIENTATION.

## GUNLOCKE

## GENERAL NOTES

1. ALWAYS PROTECT THE WORKSURFACE DURING INSTALLATION.
2. ALWAYS LEVEL UNIT(S) AT FINAL LOCATION.

### STIFFENER INSTALLATION

- 1 IDENTIFY THE CORRECT TOP SIZE BELOW AND ORIENT STIFFENERS ACCORDING TO THE DIAGRAM. ATTACH STIFFENERS TO THE WORKSURFACE USING A 1/4" DRIVE AND THE SCREWS PROVIDED.

**MULTI PIECE ROUND TOP  
(2 STIFFENERS ON SEAM SIDE)**

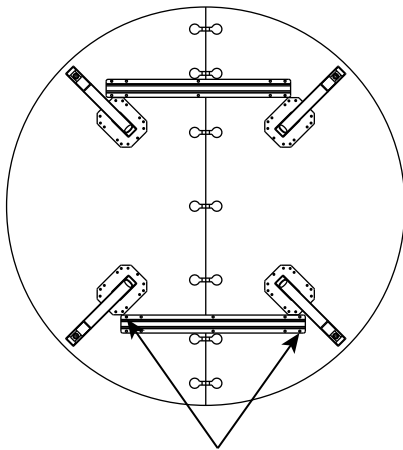

USE THESE PILOT HOLES  
FOR STIFFENER ALIGNMENT.

**MULTI PIECE ROUND TOP  
(2 STIFFENERS ON NON-SEAM SIDE)**

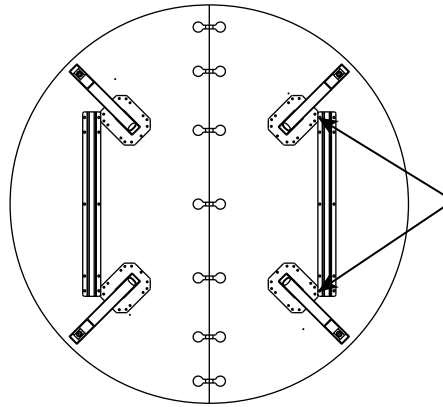

BACK STIFFENERS UP  
AGAINST THESE EDGES  
AS SHOWN

**MULTI PIECE SOFT SQUARE TOP  
(2 STIFFENERS ON SEAM SIDE)**

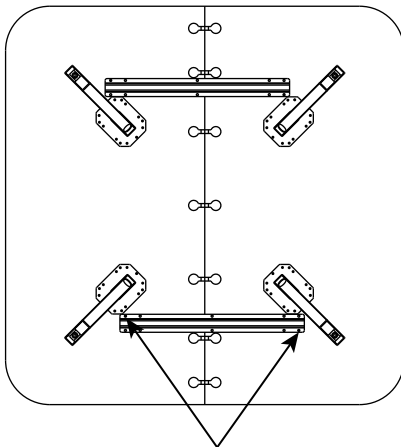

USE THESE PILOT HOLES  
FOR STIFFENER ALIGNMENT.

**MULTI PIECE SOFT SQUARE TOP  
(2 STIFFENERS ON NON-SEAM SIDE)**

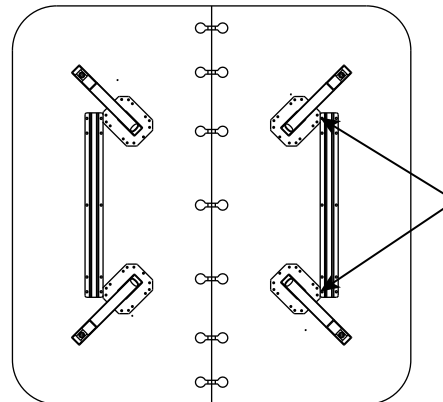

BACK STIFFENERS UP  
AGAINST THESE EDGES  
AS SHOWN

**ALTERNATE OPTION:** FOR LARGER MULTI-PIECE TOPS, TABLES CAN BE INSTALLED IN SECTIONS IF NECESSARY. FOR THIS METHOD, SET UP INDIVIDUAL SECTIONS ON THE FLOOR AS NORMAL, INSTALLING STIFFENERS TO SECTION THEY COVER THE MOST. ENSURE THEY WILL NOT CONFLICT WITH EACH OTHER OR WITH OTHER COMPONENTS WHEN FULLY ASSEMBLED. FLIP THE INDIVIDUAL SECTIONS ONE AT A TIME, AND INSTALL DOGBONES. TAKE CARE TO ENSURE TOPS ARE ALIGNED AT SEAM. FINISH PLACING SCREWS FOR STIFFENERS AND LEGS WHERE NEEDED.

## GUNLOCKE

## GENERAL NOTES

1. ALWAYS PROTECT THE WORKSURFACE DURING INSTALLATION.
2. ALWAYS LEVEL UNITS(S) AT FINAL LOCATION.

## TABLE TO STIFFENER MAPPING GUIDE

SHAPE	MODEL CODE	TABLE SIZE	STIFFENER MODEL	LENGTH	QTY
ROUND	GD2TRD54-W	54 X 54	ACMWS30	30	4
	GD2TRD60-W	60 X 60	ACMWS30	30	4
	GD2TRD66-W	66 X 66	ACMWS36	36	4
	GD2TRD72-W	72 X 72	ACMWS36	36	4
	GD2TRD78-W	78 X 78	ACMWS41	41	4
	GD2TRD84-W	84 X 84	ACMWS47	47	4
SOFT SQUARE	GD2TSSQ54-W	54 X 54	ACMWS30	30	4
	GD2TSSQ60-W	60 X 60	ACMWS30	30	4
	GD2TSSQ66-W	66 X 66	ACMWS36	36	4
	GD2TSSQ72-W	72 X 72	ACMWS36	36	4
	GD2TSSQ78-W	78 X 78	ACMWS41	41	4
	GD2TSSQ84-W	84 X 84	ACMWS47	47	4