

## Features

- Low lying levers allow easy to use hands free operation
- Angled spout to help minimise the risk of water becoming trapped
- High quality chrome finish for easy cleaning and hygiene maintenance
- Dual WELS Rating (6 and 5 Star Rating)



## Technical Information

• <b>WaterMark</b>	AS 3718 Lic. WMKA0034
• <b>WELS</b>	5 Star Rating (5.5L/min)
• <b>Nominal Flow Rate (LPM)</b>	5.27
• <b>Inlet</b>	1/2" BSP - Male
• <b>Outlet</b>	Laminar Flow
• <b>Headwork</b>	Jumper Valve
• <b>Working Pressure Range (kPa)</b>	50 Min - 500 Max
• <b>Working Temperature Range (°C)</b>	5 Min - 65 Max
• <b>Construction</b>	Brass
• <b>Finish</b>	Chrome

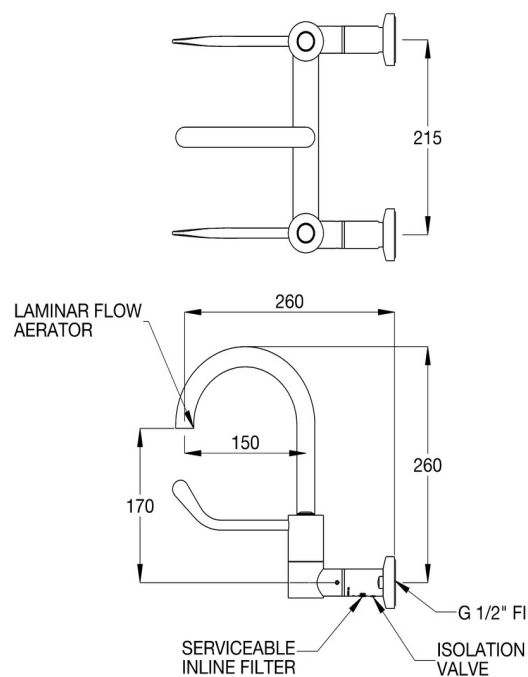

## NOTE

This product is registered via WELS with two performance ratings to ensure its suitability across a diverse array of applications. Installed in the product is the 6 Star Rating flow regulator for optimal performance. For added flexibility, the additional flow regulator is also provided within the carton. You can easily switch between regulators as needed, all while preserving the product's WELS certification. Refer to the installation instructions for a comprehensive guide on changing the flow regulator.

