**INSTALLATION • OPERATION
OWNER'S MANUAL**



ThermaCube Delivery System

**Models TCS100, TCS200, TCL100,
TCL200**

609100, 609200, 609300, 609400



CookTek Induction Systems, LLC

Toll Free: +1 (888) COOKTEK
Toll Free Fax: +1 (888) COOKFAX
Phone: +1 (312) 563-9600
Fax: +1 (312) 432-6220

www.cooktek.com
customerservice@cooktek.com

CookTek Induction Systems, LLC

Toll Free: +1 (888) COOKTEK
Toll Free Fax: +1 (888) COOKFAX
Phone: +1 (312) 563-9600
Fax: +1 (312) 432-6220

www.cooktek.com
customerservice@cooktek.com

- Não toque na placa de cerâmica (no cimo do Cooktop) imediatamente depois da sua utilização. O calor emitido pelo tabuleiro será transferido para a placa de cerâmica, fazendo com que esta fique quente ao toque.
- A assistência técnica deste produto só pode ser realizada por um agente de assistência técnica autorizado ou por pessoal da CookTek. Não tente abrir a unidade nem efectuar assistência técnica de qualquer tipo. Para informações referentes à assistência técnica, por favor entre em contacto com a CookTek pelo telefone 1-312-563-9600.
- O aparelho deve estar ligado à terra. Ligue apenas a uma tomada correctamente ligada à terra. Antes de funcionar com o aparelho, leia as instruções relativas à ligação à terra e os Requisitos para Instalação Eléctrica na Página 3 deste folheto. Não utilize um cabo de extensão.

SPANISH

Antes de utilizar el anafe (cooktop), realice lo siguiente:

- Retire todo el material de embalaje.
- Coloque la unidad sobre una superficie seca, plana, dura, estable y no inflamable.
- Mantenga la unidad alejada de otras fuentes de calor y deje un margen de al menos 5 cm para que el aire circule por los lados y las partes anterior y posterior de la unidad.

Por su seguridad, nunca corte, quite ni inutilice la conexión eléctrica (tierra) del enchufe. No utilice nunca el anafe con un enchufe adaptador ni un cable prolongador.

ADVERTENCIA: Se puede producir un choque eléctrico por un enchufe conectado a tierra de manera incorrecta. Si tiene alguna duda relacionada con las instrucciones de conexión a tierra, póngase en contacto con un electricista cualificado.

Antes de comenzar:

Asegúrese de que el cable eléctrico está unido firmemente a la unidad CookTek ANTES de conectar la unidad a la electricidad y antes de intentar utilizarla.

- No toque la placa cerámica (situada en la parte superior del anafe) inmediatamente después de utilizarla. El calor de la cazuela se transferirá a la placa cerámica y hará que ésta se caliente.
- La revisión de este producto únicamente puede realizarla un operario de mantenimiento autorizado o el personal de CookTek. No intente abrir la unidad ni realizar ninguna labor de mantenimiento. Para obtener información sobre el mantenimiento, póngase en contacto con CookTek llamando al 1-312-563-9600.
- Este aparato se debe conectar a tierra. Enchúfelo únicamente a una toma conectada a tierra de manera adecuada. Antes de utilizarlo, lea las instrucciones de conexión a tierra y los “Requisitos de la instalación eléctrica” de la página 3 de este folleto. No utilice cables prolongadores.

Dla bezpieczeństwa użytkownika nie wolno nigdy przecinać, wyjmować ani wyłączać połączenia elektrycznego (uziemienia) z wtyczki. Stosując urządzenie Cooktop nie wolno używać złącza pośredniego ani przedłużacza.

OSTRZEŻENIE: Niewłaściwe uziemienie wtyczki może spowodować porażenie prądem elektrycznym. W przypadku wątpliwości dotyczących instrukcji uziemienia należy skontaktować się z wykwalifikowanym elektrykiem.

Przed rozpoczęciem używania:

Należy sprawdzić, czy przewód zasilania jest pewnie przymocowany do modułu CookTek PRZED podłączeniem urządzenia do gniazdka zasilania i przed rozpoczęciem jego używania.

- Nie dotykać płyty ceramicznej (lub wierzchniej części urządzenia Cooktop) bezpośrednio po zakończeniu jego używania. Wysoka temperatura patelni może przenosić się na płytę ceramiczną, stwarzając możliwość oparzenia w przypadku jej dotknięcia.
- Obsługa serwisowa tego produktu może być prowadzona jedynie przez upoważnionego pracownika serwisu lub przez personel firmy CookTek. Nie podejmować samodzielnej próby otwarcia urządzenia ani nie wykonywać żadnych napraw. Aby uzyskać informacje dotyczące obsługi serwisowej, należy skontaktować się z firmą CookTek pod numerem 1-312-563-9600.
- Niniejsze urządzenie wymaga uziemienia. Podłączać jedynie do właściwie uziemionego gniazda. Przed użyciem należy przeczytać instrukcję dotyczącą uziemienia oraz część „Wymogi instalacji elektrycznej” na stronie 3 niniejszej ulotki. Nie używać przedłużacza.

PORTUGUESE

Antes de funcionar com o seu Cooktop, faça o seguinte:

- Retire todo o material de embalagem.
- Coloque a unidade numa superfície seca, nivelada, rígida, estável e não inflamável.
- Mantenha a unidade afastada de outras fontes de calor e deixe um espaço de pelo menos 5 cm nos lados, frente e traseira da unidade, para circulação do ar.

Para sua segurança, nunca corte, retire nem desactive a ligação eléctrica (terra) da ficha. Nunca utilize uma ficha adaptadora nem cabo de extensão com o Cooktop.

ADVERTÊNCIA: Uma ficha incorrectamente ligada à terra pode provocar choque eléctrico. Se tiver alguma questão sobre estas instruções de ligação à terra, por favor consulte um electricista qualificado.

Antes de Começar:

Por favor, certifique-se de que este cabo de energia está ligado firmemente à sua unidade CookTek ANTES de ligar a unidade à tomada de energia e antes de tentar funcionar com ela.

You are about to revolutionize the way food is delivered. As you read this booklet, you will begin to discover all of the benefits the CookTek ThermaCube Delivery System has to offer. We believe you will quickly come to appreciate the new level of speed, operational ease, and quality that the cordless CookTek ThermaCube brings to your delivery business. And we at CookTek are truly proud and happy to bring you this innovation. The ThermaCube is intended for use in restaurants that provide delivery and should be used solely for the purpose of keeping food hot during regular deliveries.

BEFORE USING YOUR COOKTEK THERMACUBE

PLEASE TAKE TIME TO COMPLETE THE FOLLOWING:

- Read the entire Owner's Manual and Warranty and save it for future reference.
- Record the serial number of your charger unit on the warranty page of this booklet and keep it in a safe place.
- If, upon receipt, your unit appears damaged in any way, please note the following:

Visible Loss or Damage: Any visible loss or damage must be noted on the freight bill or express receipt and signed by the person making the delivery. A claim for damages must be filed immediately, regardless of extent of damage.

Concealed Loss or Damage: If damage is not visible until merchandise is unpacked, notify the transportation company or carrier immediately, and file a "concealed damage" claim with the carrier. This should be done within fifteen (15) days of delivery date. The shipment container and packing materials must be retained for inspection.

The transportation company assumes full responsibility for the safe delivery upon acceptance of this shipment. **CookTek cannot assume responsibility for damage or loss incurred in transit.** CookTek will, however, provide any assistance and documentation necessary to support your claim.

To save time before requesting service, check the Troubleshooting chart at the end of this manual for possible solutions to your problem. It lists causes of minor operating problems that you can correct yourself without removing the housing or exposing the internal electronics. **Do not, for any reason, attempt to service or open the ThermaCube charger.** A CookTek authorized service dealer must remove the housing and perform all service to the internal electronics or you will void the warranty.

There are certain safeguards that must always be followed whenever the ThermaCube is used. To reduce the risk of fire, electrical shock or injury, be sure to read all of the following:

Read and follow all instructions carefully.

- The ThermaCube charger in the United States is equipped with a three-prong electrical plug. This three-prong plug is part of a system that will protect you from serious injury if something goes wrong with the electrical wiring in the charger. Be sure the three-prong plug is plugged into a matching three-prong socket that is properly grounded. **WARNING! DO NOT cut or break off the**

- large third prong in this plug, or change the plug or power cord in any way.
- Make sure that incoming voltage matches unit requirements. A product identification label on the bottom of the charger specifies the operating voltage, wattage, current, frequency, and phase of the unit. Plugging or wiring the charger into a power source differing from the unit rating may significantly decrease the performance or severely damage electronic components.
 - Unplug the charger before cleaning. **Do not submerge the charger in water.** Do not splash or pour water onto the charger's control panel or into intake/outlet vents. Possible shock hazard may result and the unit may be damaged.
 - Do not use steel wool or abrasive cleaners on the metal housing or plastic locator tray surface.
 - The ThermaCube chargers and pellets are intended for use with CookTek designed and approved bags only. Do not attempt to use unapproved or damaged delivery bags, trays, or pellets.
 - Do not place foreign objects on the charger, or between the delivery bag and charger. Foreign objects placed on the charger or between the charger and bag or inside the bag may overheat and cause damage to the charger and/or bag.
 - Do not use any ThermaCube charger that has a damaged cord or plug. Consult the warranty and follow instructions for service.
 - Do not let the ThermaCube charger cord touch hot surfaces.
 - Please do not attempt to open the unit or perform service of any kind. **This product can only be serviced by a CookTek Authorized Service Agent or designated CookTek personnel.** Contact CookTek at +1 (312) 563-9600 for service information.
 - The charger top may get hot to the touch after hours of continuous use. Use caution when loading and unloading delivery bags.
 - Do not place any objects in the delivery bag while it is on the charger.

Every installation site has different electrical wiring requirements. Because many different local codes exist, **it is the Owner and Installer's responsibility to comply with ALL applicable codes.** CookTek is not responsible for any consequential damages, either expressed or implied, as a result of failure to comply with installation requirements.

A dedicated electrical line is recommended for EACH ThermaCube unit.

PRIOR TO INSTALLATION

- Read all installation instructions carefully before starting installation.
- Remove charger carefully from carton. Save all packaging materials for subsequent shipment or in case of concealed shipping damage.
- Remove all loose packaging and accessories.
- It is the responsibility of the installer to comply with all federal, state, and local codes.
- Any installation not matching the requirements discussed in this manual will automatically void the product's warranty.

- Questo prodotto può essere riparato esclusivamente da un tecnico autorizzato o dal centro di assistenza CookTek. Non tentare di aprire l'unità o di eseguire interventi di manutenzione di alcun tipo. Per informazioni sull'assistenza, contattare la CookTek al numero 1-312-563-9600.
- Questo apparecchio deve essere collegato a terra. Collegarlo esclusivamente a una presa elettrica dotata di messa a terra. Prima di mettere in funzione l'unità, leggere le istruzioni di messa a terra e i Requisiti di installazione elettrica a pagina 3 di questo opuscolo. Non utilizzare un cavo elettrico di prolunga.

NORWEGIAN

Før du bruker komfyren, må du gjøre følgende:

- Fjern all emballasje.
- Plasser enheten på et tørt, jevnt, hardt, stabilt og brannsikkert underlag.
- Hold enheten unna andre varmekilder, og la det være minst 5 cm klaring for luftventilasjon på sidene, foran og på baksiden av enheten.

For din egen sikkerhet må du ikke kutte, fjerne eller ødelegge den elektriske (jordede) kopligen fra kontakten. Ikke bruk en adapterkontakt eller skjøteledning for komfyren.

ADVARSEL: Elektrisk støt kan oppstå fra kontakt som ikke er korrekt jordet. Ta kontakt med en kvalifisert elektriker dersom du har spørsmål om disse jordingsinstruksene.
Før du begynner:

Kontroller at strømkabelen er satt helt inn i CookTek-enheten FØR du kopler enheten til stikkkontakten og før bruk.

- Den keramiske platen (eller overflaten på komfyren) må ikke berøres umiddelbart etter bruk. Varme fra kjeler vil overføres til den keramiske platen og gjøre den varm.
- Dette produktet kan bare repareres av en autorisert serviceagent eller av CookTek-ansatte. Ikke prøv å åpne enheten eller utføre reparasjoner av noe slag. For serviceinformasjon, kontakt CookTek på tlf. 1-312-563-9600.
- Dette produktet må jordes. Må kun koples til et korrekt jordet støpsel. Før bruk bør du lese jordingsinstruksene og kravene til elektrisk installasjon på side 3 i denne veiledningen. Ikke bruk skjøteledning.

POLISH

Przed rozpoczęciem używania urządzenia Cooktop, należy wykonać poniższe czynności:

- Usunąć wszystkie elementy opakowania.
- Ustawić urządzenie na suchej, poziomej, twardej, stabilnej i niepalnej powierzchni.
- Ustawić urządzenie z dala od innych źródeł ciepła i zapewnić wokół urządzenia wolną przestrzeń, co najmniej 0,5 cm, aby umożliwić obieg powietrza

ΠΡΟΕΙΔΟΠΟΙΗΣΗ: Ένα εσφαλμένα γειωμένο φως μπορεί να έχει ως αποτέλεσμα την ηλεκτροπληξία. Παρακαλείστε να συμβουλευτείτε αρμόδιο ηλεκτρολόγο εάν έχετε τυχόν ερωτήσεις σχετικά με αυτές τις οδηγίες γείωσης.

Πριν ξεκινήσετε:

Βεβαιωθείτε ότι αυτό το ηλεκτρικό καλώδιο είναι σταθερά συνδεδεμένο στη μονάδα CookTek σας ΠΡΙΝ συνδέσετε το φως της μονάδας σε ηλεκτρική πρίζα και πριν προσπαθήσετε να θέσετε τη μονάδα σε λειτουργία.

- Μην αγγίξετε την κεραμική πλάκα (ή το άνω μέρος του Cooktop) αμέσως μετά τη χρήση. Η θερμότητα από την κοιλότητα θα μεταφερθεί στην κεραμική πλάκα. Ως εκ τούτου, αυτή θα είναι πολύ ζεστή για να την αγγίξετε.
- Οι εργασίες επισκευής του προϊόντος αυτού πρέπει να πραγματοποιούνται μόνο από εξουσιοδοτημένο αντιπρόσωπο επισκευών ή από προσωπικό της CookTek. Μην επιχειρήσετε να ανοίξετε τη μονάδα ή να εκτελέσετε οποιαδήποτε εργασία επισκευής σε αυτήν. Για πληροφορίες σχετικά με τις επισκευές, επικοινωνήστε με την CookTek στον τηλεφωνικό αριθμό 1-312-563-9600.
- Η συσκευή αυτή πρέπει να είναι γειωμένη. Συνδέστε μόνο σε σωστά γειωμένη πρίζα. Πριν τη λειτουργία, διαβάστε τις οδηγίες γείωσης και τις απαιτήσεις ηλεκτρικής εγκατάστασης στη σελίδα 3 του παρόντος φυλλαδίου. Μη χρησιμοποιείτε καλώδιο προέκτασης (μπαλαντέζα).

ITALIAN

Prima di mettere in funzione il piano cottura, eseguire le seguenti operazioni:

- Rimuovere tutto il materiale di imballaggio.
- Collocare l'unità su una superficie asciutta, piana, rigida, stabile e non infiammabile.
- Tenere l'unità lontana da altre fonti di calore e lasciare almeno 5 centimetri di spazio per consentire la circolazione dell'aria tutto intorno all'unità.

Per la propria sicurezza, non tagliare, rimuovere o disattivare mai il collegamento elettrico di terra dalla spina. Non utilizzare mai una spina adattatore o un cavo elettrico di prolunga per collegare il piano cottura.

AVVERTENZA: una spina elettrica non correttamente collegata all'impianto di terra può provocare scosse elettriche. Rivolgersi a un elettricista qualificato in caso di domande su queste istruzioni di messa a terra.

Prima di iniziare:

Assicurarsi che questo cavo di alimentazione sia collegato saldamente all'unità CookTek PRIMA di collegare l'unità alla presa elettrica e prima di metterla in funzione.

- Non toccare la piastra di ceramica (o la superficie del piano cottura) subito dopo l'uso. Il calore della pentola si trasferisce alla piastra di ceramica, rendendola estremamente calda.

INSTALLATION

- The ThermaCube charger can be installed on top of, or recessed into a flat, level counter top or shelving unit, being careful to maintain at least two inches of clearance on all sides and six inches below the unit for cooling. (Six inches below is not required for top of counter or top of shelf installation.)
- When installing the ThermaCube charger in a drop-in or recessed application, allow adequate clearance for the rear air vents and power cord.
- ThermaCube charger should be plugged into a grounded outlet, single phase 120VAC or 240VAC receptacle dependant on model. The ThermaCube charger will operate between 208-240VAC and 100-120VAC. Check rating plate on unit to verify correct voltage. All models draw up to 1800W. Unit will run at voltages less than 120VAC or 240VAC but will result in less than rated power and slower charging times.
- If unit is dropped into an enclosed counter top, there should be an opening near the unit for fresh air to circulate underneath.

NOTE Each ThermaCube charger should be connected to its own DEDICATED circuit. They should not be connected to circuits sharing compressors or other heavy current draw devices.

- Do not move the ThermaCube when it is electrically connected.

OPERATING INSTRUCTIONS

- Make sure that your ThermaCube charger is plugged into an energized circuit as described in the previous section. This should be a dedicated circuit, not shared with any devices utilizing motors, compressors, or components requiring a heavy current draw.
- The ThermaCube is turned on by pressing the "POWER" button on the front of the membrane panel. An LED will illuminate indicating that the ThermaCube charger is turned on and ready for use.
- Place a CookTek approved bag on each ThermaCube charger.
- The red "CHARGING" LED will illuminate indicating that the bag is charging. **Do Not Remove** the bag from the ThermaCube charger while the red LED is illuminated. The bag may not fully charge resulting in a lower delivery temperature. **NOTE: You will hear three loud "BEEPS" if you remove the bag before it is fully charged.**
- Delivery Bags and other objects should be removed from the ThermaCube charger overnight or if the ThermaCube charger is not being used for an extended period of time.
- If the red "CHARGING" LED does not illuminate, remove and reposition the bag.
- When the bag has completely charged, the green "READY" LED will illuminate indicating that the bag is fully charged and is now ready for delivery. Charge time for cold, or room temperature bags will be approximately 3 1/2 minutes. After the first charge, recharges will take approximately 60 seconds or less, depending on the residual energy in the bag/pellet.

NOTE: If a charged bag is not used for approximately 12 minutes and 20% of the energy in the pellet is lost, the green "READY" LED will turn off. Simply lift the bag off of the charger and set it back on the charger to bump the charge back up to 100%.

- When an order is ready for delivery, remove a charged bag from any ThermaCube charger with an illuminated green “READY” LED and load food for delivery.
 - Immediately place another bag on the ThermaCube charger making sure that the red “CHARGING” LED illuminates.
 - Make sure that a bag is on the ThermaCube charger at all times. This will ensure that all deliveries are made with a heated bag.
 - Each evening before you close your store, turn off all ThermaCube chargers by depressing the “POWER” button. All membrane panel LEDs should turn off.
- NOTE: The cooling fan will continue to run and will turn off approximately 20 seconds after the power is turned off.**
- Bags must be removed from the charger at night.

GREASE FILTER CLEANING PROCEDURES

This unit comes equipped with a grease filter(s) to protect the electronics from contaminants.

Frequency

- Grease filter(s) should be removed and cleaned every two weeks. More frequent cleaning may be necessary if they appear clogged and/or operate in heavy grease laden environments.

Procedure

- Slide filter(s) out of the track on the bottom of the unit.
- Back flush with hot water to remove dirt and grease.
- Shake remaining water out and let stand until completely dry.
- Reinstall filter(s) ensuring the arrow on the edge of the filter(s) is pointing into the unit.
- NOTE: Filter(s) are also dishwasher safe.

Caution

- Do not operate the unit without the grease filter(s) installed.
- If the unit displays an error code of “E4” - the overheat error - this may indicate a clogged filter. Follow the procedure above and let the unit cool down before resuming operation (turn off for approximately five (5) minutes).

TROUBLE-SHOOTING

The CookTek ThermaCube is a very intelligent device. Built in diagnostics can help you determine the cause of most problems. The following section explains how to diagnose a problem and what can be done to correct the problem. This information can be very helpful if you are calling out Customer Service department to report any operational difficulties.

- Errors are indicated by a number of consecutive audible “beeps” and the repeated flashing of the “RESET” LED.
- If an error occurs, remove the bag from the charger and depress the “RESET” button. Make sure that the bag is properly positioned on the charger.
- When the “POWER” LED illuminates, place the bag back on the unit to continue charging.
- If an error persists remove the bag from the charger, turn the power off, and unplug the unit. Plug the unit back in and turn the unit on by pressing the “POWER” button.
- When the green “POWER” LED illuminates, place the bag back on the unit to continue charging. Make sure that the bag is properly positioned on the charger.

GERMAN

Vor Inbetriebnahme des Cooktop verfahren Sie bitte wie folgt:

- Entfernen Sie das gesamte Verpackungsmaterial.
- Stellen Sie das Gerät auf eine trockene, ebene, harte, stabile und nicht brennbare Fläche.
- Halten Sie das Gerät von anderen Wärmequellen fern und lassen Sie um das Gerät herum (vorne, hinten und seitlich) mindestens 5 cm für die Luftzirkulation frei.

Zu Ihrer eigenen Sicherheit darf das Erdungskabel keinesfalls vom Stecker abgetrennt, entfernt oder in schadhaftem Zustand verwendet werden. Benutzen Sie für Ihren Cooktop niemals einen Steckeradapter oder ein Verlängerungskabel..

WARNHINWEIS: Ein nicht fachgemäß geerdeter Stecker kann zu einem Stromschlag führen. Falls Sie noch Fragen zu diesen Anweisungen in Zusammenhang mit Schutzkontakt und Erdung haben, wenden Sie sich bitte an einen Elektrofachmann.

Bevor Sie beginnen:

Dieses Netzkabel muss fest mit dem CookTek verbunden sein, BEVOR Sie das Gerät an die Steckdose anschließen und es in Betrieb nehmen.

- Berühren Sie die Keramikplatte (oder Oberfläche des Cooktop) nicht unmittelbar nach Gebrauch. Die Hitze der Pfanne überträgt sich auf die Keramikplatte, die dann ebenfalls heiß wird.
- Dieses Produkt darf nur durch bevollmächtigte Wartungstechniker oder das Fachpersonal von CookTek gewartet werden. Versuchen Sie nicht, das Gerät zu öffnen und selbst zu warten. Nähere Informationen zur Wartung erhalten Sie bei CookTek unter der Rufnummer 1-312-563-9600.
- Das Gerät muss geerdet werden. Der Stecker muss in eine ordnungsgemäß geerdete Steckdose gesteckt werden. Vor dem Öffnen lesen Sie bitte die Anweisungen zu Schutzkontakt/Erdung und die Anforderungen an die elektrische Installation auf Seite 3 dieses Handbuchs. Verwenden Sie kein Verlängerungskabel.

GREEK

Πριν θέσετε το Cooktop σας σε λειτουργία, εκτελέστε τα ακόλουθα:

- Αφαιρέστε όλα τα υλικά συσκευασίας.
- Τοποθετήστε τη μονάδα σε μια στεγνή, επίπεδη, σκληρή, σταθερή και μη εύφλεκτη επιφάνεια.
- Διατηρήστε τη μονάδα μακριά από άλλες πηγές θερμότητας και αφήστε κενό τουλάχιστον 2 ίντσες (5 εκατοστά) για την κυκλοφορία του αέρα στα πλαϊνά, το μπροστινό μέρος και το πίσω μέρος της μονάδας.

Για την ασφάλειά σας, ποτέ μην κόψετε, αφαιρέσετε ή απενεργοποιήσετε την ηλεκτρική (γείωση) σύνδεση από το φως. Μη χρησιμοποιήσετε ποτέ προσαρμογέα φως ή καλώδιο προέκτασης (μπαλαντζά) με το Cooktop.

Ennen kuin aloitat:

Varmista, että tämä virtajohto on tiukasti kiinnitetty CookTek:iin ENNEN laitteen pistokkeen työntämistä pistorasiaan ja ennen käyttökokeilua.

- Älä koske keraamista levyä (keittotason päällä) heti käytön jälkeen. Astian kuumuus siirtyy keraamiseen levyyn kuumentaen sen liian kuumaksi koskettaa.
- Tätä tuotetta saa huoltaa ainoastaan valtuutettu huoltopiste tai CookTekin henkilökunta. Älä yritä avata laitetta ja suorittaa sille minkäänlaisia huoltotoimia. Tietoja huollosta saat soittamalla CookTekiin numeroon +1-312-563-9600.
- Tämä laite täytyy suojamaadoittaa. Liitä ainoastaan oikein suojamaadoitettuun pistorasiaan. Ennen käyttöä lue maadoitusohjeet ja sähköasennusvaatimukset tämän lehtisen sivulta 3. Älä käytä jatkojohtoa.

FRENCH

Avant d'utiliser l'appareil Cooktop, effectuer les opérations suivantes :

- Retirer tous les matériaux d'emballage.
- Placer l'appareil sur une surface sèche, plane, solide, stable et non inflammable.
- Placer l'appareil à distance de toute autre sources de chaleur et laisser un espace libre d'au moins 5 cm (2 pouces) des deux côtés, à l'avant et à l'arrière de celui-ci pour permettre la circulation de l'air.

Pour votre sécurité, ne jamais couper, déconnecter ou désactiver le raccordement électrique (terre) de la prise de courant. Ne jamais utiliser un adaptateur ou une rallonge électrique avec l'appareil Cooktop.

MISE EN GARDE : Une prise de courant incorrectement raccordée à la terre engendre un risque de choc électrique. Pour toute question concernant ces instructions de mise à la terre, consulter un électricien qualifié.

Avant de commencer :

S'assurer que le câble d'alimentation est solidement fixé à l'appareil CookTek AVANT de raccorder l'appareil à une prise de courant et d'essayer de le faire fonctionner.

- Ne pas toucher la plaque de céramique (ou la partie supérieure de l'appareil Cooktop) immédiatement après utilisation. La chaleur de la casserole se transmet à la plaque de céramique, aussi celle-ci est chaude au toucher.
- L'entretien de cet appareil ne peut être effectué que par un réparateur agréé ou par un membre du personnel de CookTek. Ne jamais essayer d'ouvrir l'appareil ni de le réparer. Pour des informations concernant l'entretien, contacter CookTek au +1-312-563-9600.
- Cet appareil doit être raccordé à la terre. Le brancher exclusivement à une prise de courant correctement raccordée à la terre. Avant utilisation, lire les instructions de raccordement à la terre, ainsi que les exigences en matière d'installation électrique figurant à la page 3 du présent manuel. Ne pas utiliser de câble de rallonge.

NOTE: If the ThermaCube unit does not see any activity for an extended period of time, you will initially hear two beeps and then you will see the "POWER" LED flash constantly. This is **NOT** an error code, merely an indication that the unit has entered a power saving "sleep" mode. To exit "sleep" mode, press the "RESET" button.

ERROR CODES FOR THERMACUBE UNITS

Error codes will be indicated by a number of beeps and the flashing "RESET" LED. Count the number of beeps in a row. This will be the error number. If there is more than one error condition, there will be a pause and then the unit will beep the next error number. It will continue to repeat this cycle until the ThermaCube is reset. To reset the ThermaCube from an Error mode, remove the bag from the unit and press the "RESET" button. If the unit does not reset, turn the unit off, unplug the power cord, wait 5 seconds, and then plug it in again.

Error	Error Description	Potential Cause	Action Required
2	Time Out	Low line voltage.	Check line voltage/wattage. Inspect RFID heating panel; replace if damaged.
3	Current draw is too high	A metallic object may be present on the charger or there may be mechanical damage to the work coil. RFID panel not placed properly	Remove bag and check for foreign objects between the box and the charger. Retry. If problem persists, contact service agent. Inspect panel and change if damaged or warping present.
4	Electronics are overheating.	Fan broken, air path blocked, or intake air too hot.	Check airflow. Clear air vents. Listen for fan operation. Clean grease filter. If problem persists, call service agent.
6	Over voltage	Voltage exceeds 264 on 240V model or 132 on 120V model.	Verify mains voltage. If problem persists, contact service agent.
7	Hardware failure	Board component failure.	Turn unit off, then on. Unplug & wait 10 seconds. Retry. If problem persists, call service agent.
8	Zero cross error	Bad AC source, board component failure	Verify line frequency. If problem persists, call service agent.
9	RFID Time failure	Date and time corrupted.	Contact service agent.
15	Communication error	RFID and CPU boards not communicating	Contact service agent.
16	Critical system failure	Critical hardware/software problem	Unplug charger and wait 5 minutes. Retry. If problem persists, call service agent.

TROUBLESHOOTING

If you have this	Check This
No power	<ul style="list-style-type: none">• Make sure that the power cord is firmly plugged into your power source• Make sure that your power source is energized• Firmly press the "POWER" button on the front of the ThermaCube• Try the unit in a different, known good, outlet
"Charge" LED does not turn on when bag is placed on tray.	<ul style="list-style-type: none">• Make sure there is a CookTek pellet in the CookTek approved delivery bag.• Make sure that your bag is positioned properly on the ThermaCube tray. You may have to press the bag down lightly to properly position a new or stiff bag.• Make sure that there are no foreign or metallic objects on top of the ThermaCube top tray, between the ThermaCube and the bag, or inside the bag.
Bag not heating properly	<ul style="list-style-type: none">• Make sure that the ThermaCube is plugged into an energized power source and the "POWER" LED is illuminated.• Check to make sure that your bag is assembled correctly.• Make sure that your bag is positioned properly on the ThermaCube tray. You may have to press the bag down lightly to properly position a new or stiff bag.

WARRANTY STATEMENT

All commercial cooking equipment manufactured by CookTek is warranted against defects in materials and workmanship for a period of one year from the date of sale, or 18 months from the date of shipment from our factory, whichever comes first. **IMPORTANT!** Keep a copy of your sales receipt to verify date of purchase. A valid proof of purchase, indicating Serial Number(s) and date of purchase is required to obtain Warranty Service. This warranty is for the benefit of the original purchaser and is non-transferable. Any defects in materials or workmanship, which are brought to the attention of CookTek by written notification within the aforesaid warranty period will be repaired or replaced, at CookTek's discretion, with new or recertified products or parts. **THIS IS THE SOLE REMEDY FOR ANY BREACH OF THIS WARRANTY. IN NO EVENT WILL COOKTEK BE LIABLE FOR DAMAGES OF ANY KIND, WHETHER DIRECT OR INDIRECT, SPECIAL OR CONSEQUENTIAL.**

THIS WARRANTY IS THE COMPLETE AND ONLY WARRANTY, EXPRESS OR IMPLIED IN LAW OR FACT, INCLUDING BUT NOT LIMITED TO, WARRANTIES OF MERCHANTABILITY, SUITABILITY, QUALITY, OR FITNESS FOR ANY PARTICULAR PURPOSE.

(continued...)

MANUAL TRANSLATION ADDENDUM

DUTCH

Doe het volgende voordat u uw kooktop gaat gebruiken:

- Verwijder al het verpakkingsmateriaal
- Zet het toestel op een droge, vlakke, harde, stabiele en onbrandbare ondergrond
- Houd het toestel uit de buurt van andere warmtebronnen en zorg dat er aan de voor- en achterkant en de zijkanten minstens 5 cm vrij is voor luchtcirculatie.

Voor uw veiligheid mag u nooit de elektrische (massa) aansluiting uit de stekker snijden, verwijderen of uitschakelen. Gebruik nooit een aangepaste stekker of een verlengsnoer met de kooktop.

WAARSCHUWING: Een verkeerd gearde stekker kan u een elektrische schok bezorgen. Raadpleeg een erkende elektricien als u vragen heeft over deze aardingsinstructies.

Voordat u begint:

Controleer eerst of dit snoer stevig aan uw CookTek-apparaat is bevestigd **VOORDAT** u de stekker van het toestel in het stopcontact steekt en u probeert het te gebruiken.

- Raak de keramische plaat (of de bovenkant van de kooktop) nooit onmiddellijk na gebruik aan. De hitte van de pan wordt op de keramische plaat overgebracht zodat deze heet is bij aanraking.
- Dit product mag uitsluitend worden gerepareerd door een geautoriseerd servicebedrijf of door personeel van CookTek. Probeer niet om het toestel open te maken of op enige wijze te repareren. Neem voor informatie over onderhoud en reparatie contact op met CookTek op 001-312-563-9600.
- Dit toestel moet worden geaard. Alleen aansluiten op een goed geaard stopcontact. Lees voor het gebruik de aardingsinstructies en de vereisten voor de elektrische aansluiting op pagina 3 van dit boekje. Gebruik geen verlengsnoer.

FINNISH

Ennen keittotason käyttöä toimi seuraavasti:

- Poista kaikki pakkausmateriaalit.
- Laita laite kuivalle, tasaiselle, kovalle, tukevalle ja palamattomalle pinnalle.
- Pidä laite erossa muista lämmönlähteistä ja jätä laitteen sivuille, eteen ja taakse vähintään 10 cm (2 tuumaa) vapaa tilaa ilmalle kiertää.

Turvallisuussyistä älä koskaan leikkaa, irrota tai pura sähköliitoksia (maadoitusjohtoa) pistokkeesta. Älä koskaan käytä keittotason kanssa sovitinpistoketta tai jatkojohtoa.

VAROITUS: Väärin maadoitettu pistoke voi aiheuttaa sähköiskun. Neuvottele valtuutetun sähköasentajan kanssa, jos sinulla on kysyttävää näistä maadoitusohjeista.

TCS Charger

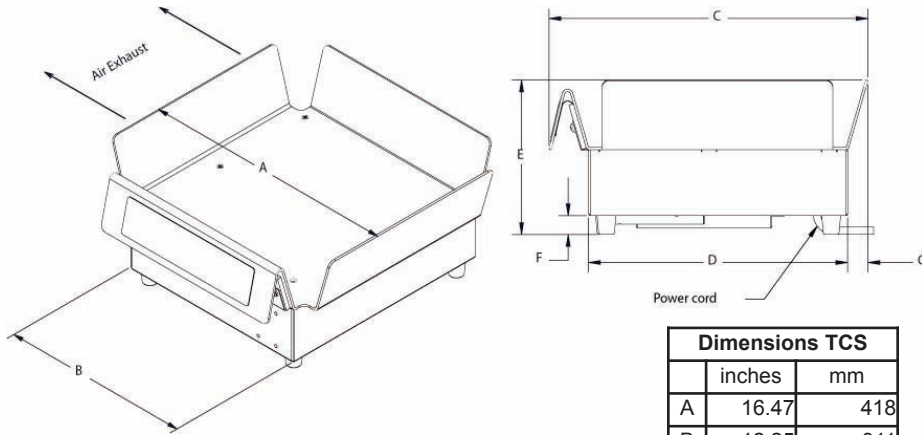

Dimensions TCS		
	inches	mm
A	16.47	418
B	12.25	311
C	16.93	430
D	13.75	349
E	8.18	208
F	1.00	25
G	1.08	27

This warranty is void if it is determined that upon inspection by an authorized service agent that the equipment has been modified, misused, misapplied, improperly installed, or damaged in transit by fire, flood, or act of God. Warranty will be considered void if the serial nameplate has been removed or if the unit has been opened or modified in any way, or service has been attempted by unauthorized personnel. The prices charged by CookTek for its products are based upon the limitations in this warranty. Seller's obligation under this warranty is limited to the repair of covered defects without charge by a CookTek factory authorized service agent or one of its sub-service agencies.

To receive Warranty Service, please call CookTek at +1 (312) 563-9600 to obtain a Return Authorization (RA) number. This RA number must be printed on the outside of the return shipping container, or on the address label when returning units for service. Units received without an RA will be refused at our shipping dock and may encounter a delay in service. Units must be taken or shipped to the required authorized service agency with transportation charges prepaid for service. CookTek will provide return freight. In addition to restrictions contained in this warranty, specific limitations are shown in the Service Policy and Procedure Guide. Please save all packaging materials for possible use in shipping. CookTek assumes no liabilities whatsoever for any damages incurred in transit.

This warranty is valid in the Continental United States only if purchased through an authorized CookTek Representative or Dealer. This warranty is valid outside of the Continental United States only if purchased through an authorized CookTek International Distributor. Warranty service is provided only through the Authorized Agent from which the unit was purchased.

For additional information and other details concerning warranty, please contact our Service Department at:

In the United States:

CookTek
 Toll Free: +1 (888) COOKTEK (266-5835)
 Toll Free Fax: +1 (888) COOKFAX (266-5329)

Outside of the United States:

Phone: +1 (312) 563-9600
 Fax: +1 (312) 432-6220

Worldwide Web

www.CookTek.com
 Email: customerservice@cooktek.com

TCL Charger

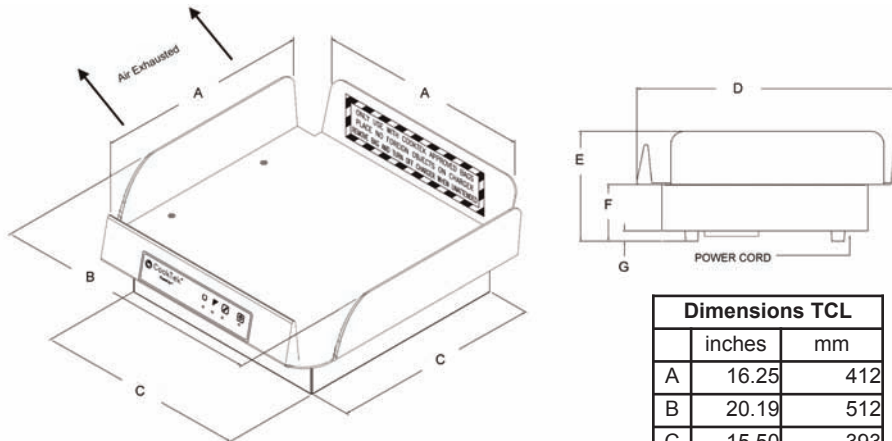

Dimensions TCL		
	inches	mm
A	16.25	412
B	20.19	512
C	15.50	393
D	21.63	549
E	8.55	217
F	4.55	115
G	1.00	25

SPECIAL NOTES - THERMACUBE

These notes are designed to assure trouble free operation of your CookTek ThermaCube.

Bag Assembly Procedure

The CookTek bag has a large arrow marked on the inside. When inserting the pellet tray assembly make sure that the arrow on the pellet tray assembly is lined up with the arrow on the inside of the bag.

Each side of the bag contains a stiffener to help the bag maintain its shape. These stiffeners should be placed in each side pocket, and each side pocket should then be closed with the Velcro strips.

There is an optional Velcro divider which can be used to create two or four compartments inside the bag. Simply unfold the divider, and attach the Velcro strips to the Velcro strips on the inside of the bag.

Preventative Maintenance

The CookTek ThermaCube units have cooling vents located on the bottom and back of the unit. It is very important to keep these vents open and free from accumulated dust or dirt. It is highly recommended that you add the cleaning of these vents to your standard maintenance list. Unplug the unit, carefully turn the unit on its side, and wipe off any accumulated dust and dirt.

Regular System and Bag Checks - Points to Remember

- Periodically check to make sure all Velcro seams and pockets are clean and properly closed.
- Make sure that the pellet tray assemblies are inserted into the bags so that the arrows on each piece match up.
- Check for foreign objects in the bag. These objects should be removed immediately.
- When charging bags, make sure that the bag is properly positioned and that the top is properly closed.
- Use only CookTek approved bags and pellets. **Other systems are NOT COMPATIBLE.**
- **Do not** use bags that appear ripped or damaged in any way.
- **Do not** wash bags with the pellet tray assembly or stiffeners. Remove these items prior to washing. After washing, make sure the bags are reassembled correctly as described above.
- **Do not** place any items on top of the ThermaCube tray or under the bags, especially while charging.
- Periodically check the condition of the stiffeners. If they are cracked or damaged, they should be replaced immediately.
- Periodically check the condition of the CookTek pellet. If the pellet appears damaged, it should be replaced immediately.
- Do not place any foreign objects or paper under the ThermaCube unit. These items may obstruct the fan intake, causing the unit to overheat.
- Do not place more than one bag at a time on the ThermaCube unit.

Questions? Contact CookTek Customer Service
+1-888-COOKTEK • www.CookTek.com

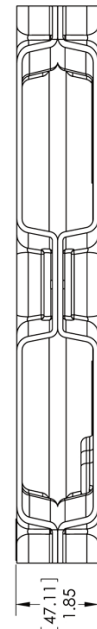
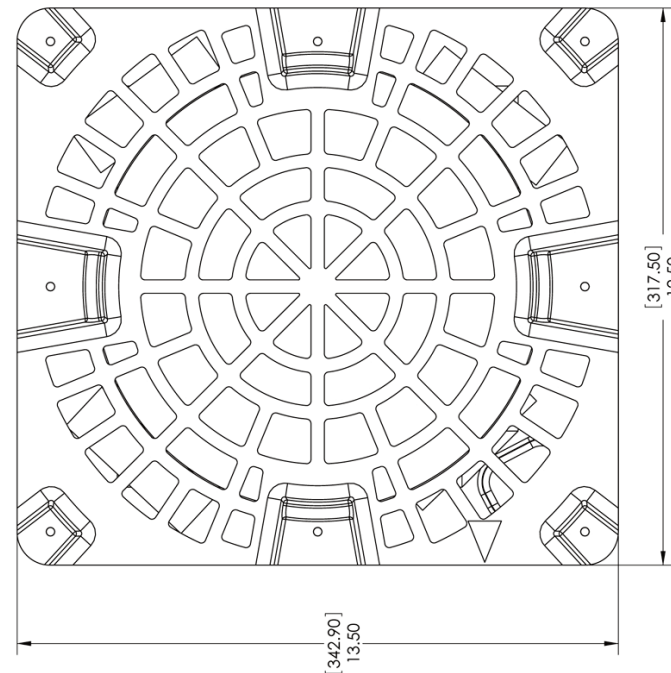
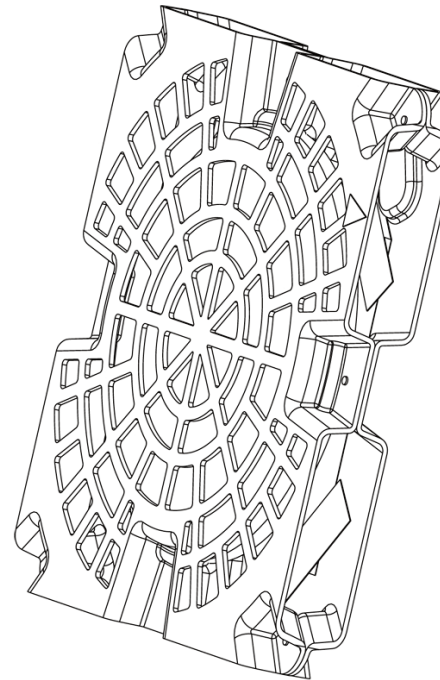

Tray Assembly
FILE NAME: 301403-RO
DATE: 4/29/07
DRAWN BY:
Sheet 01 of 1