

V2 Integrated Wash Basin

Model: SPPL.SE.WB.HD.xxx

SPPL = Stoddart Plumbing Product
 SE = Safe Ensuite
 WB = Basin
 HD = High Sided Integrated Splashback with Dual Outlet
 eg.: for specification and ordering quote
 Code: SPPL.SE.WB.HD.080

Features and Benefits:

- Ideal for specialist hospitals, clinics, care homes and custodial applications
- Constructed from GRP moulded High Performance impact resistant material with polyester gel coat, formulated to resist chemicals and ultra violet rays
- Basin and moulded soap shelves
- Moulded impact resistant
- Vandal and ligature resistant
- Wave-on and tactile activation sold separately

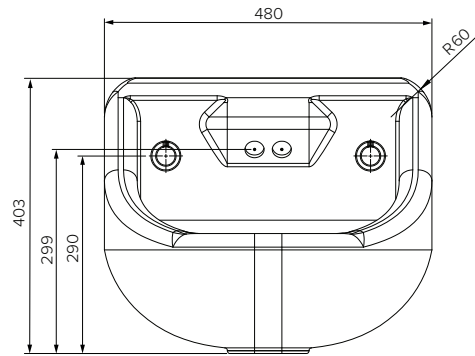

Front View

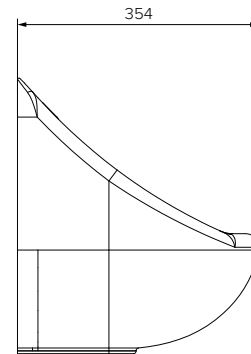

End View

Sold Separately

Sensor Options:

Tactile Switch Options:



Specifications:

Construction: GRP High Performance Composite material
 Gross Weight: 13.6kg
 Tap Outlet: Integrated stainless steel water spout set at 5L /min
 Waste Outlet: Rear concealed waste outlet
 Waste Grid: 316 grade Stainless Steel anti-ligature
 Cable Length: 3 metres (8/15m cable P.O.A available upon request)
 Unit Fixing: Secure to wall with provided 4 x 10mm Stainless Steel all thread - to suit 100mm wall thickness only.

Model No.	Description	L x W x H (mm)
SPPL.SE.WB.HD.080	Dual sensor, dual outlet	480 x 354 x 403

Due to continuous product research and development, the information contained herein is subject to change without notice.

Revision: 24/06/2021