

PLAN VIEW

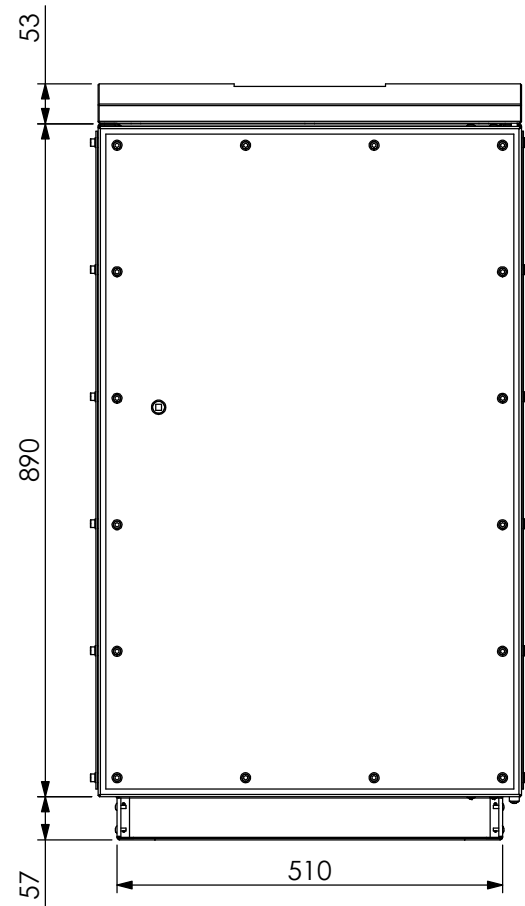

FRONT ELEVATION

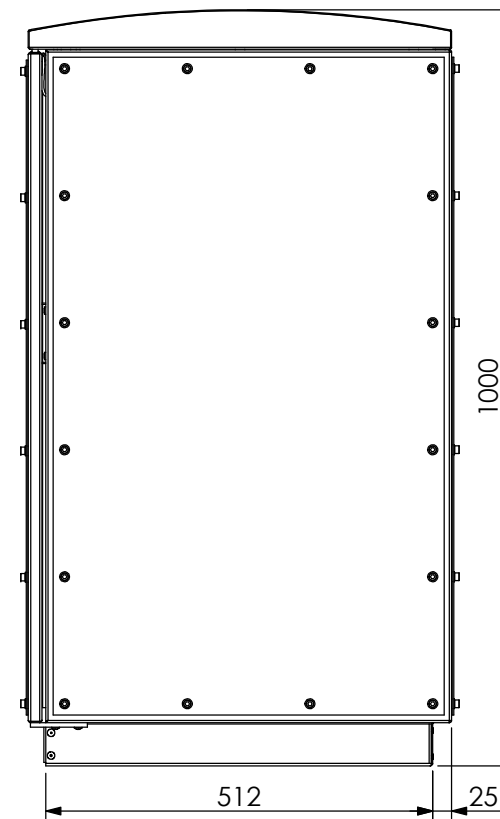

SIDE ELEVATION

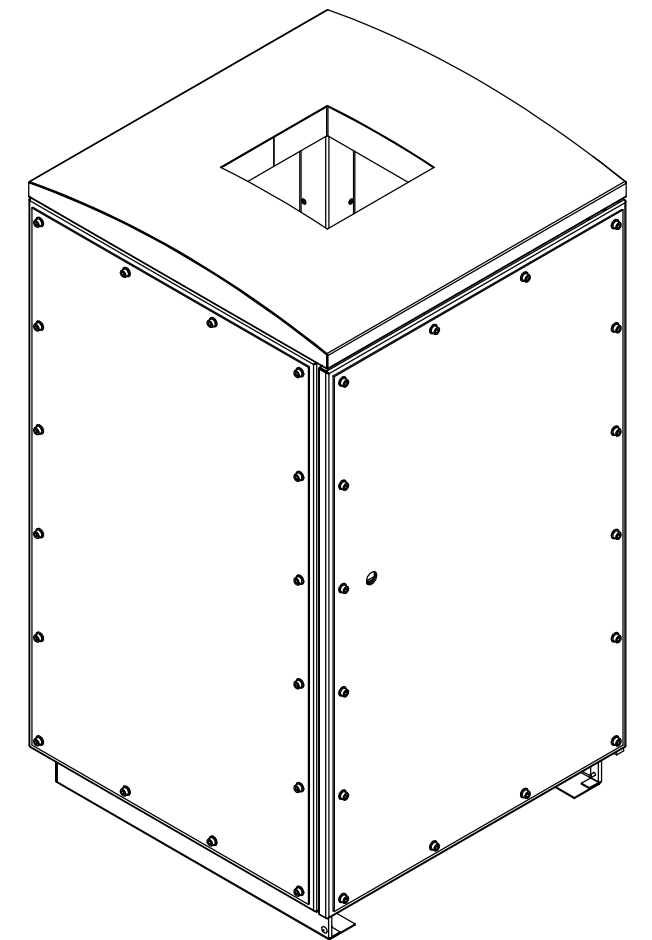

ISOMETRIC

REV.	NAME	DATE	DESCRIPTION
A	M.RATTRAY	8/07/2014	120 LTR BIN FRAME P/COAT PANELS



STODDART
MANUFACTURING
 TOM STODDART Pty Ltd
 ACN 009 690 251
 www.stoddart.com.au

				PART No: SPTP-MB3-A-SFL-120-PC A1	
DRAWN	M Rattray	SIGNATURE	DATE	UNLESS OTHERWISE SPECIFIED: DIMENSIONS ARE IN MILLIMETERS	
APPV'D				MATERIAL: REFER COMPONENTS	
Weight:		THICKNESS: N/A		DESCRIPTION: T&P; Mobile Bin; Alum; SS Flat Lid; 120 Ltr; Powdercoat	
Surface Area:		FINISH: P/COATED		DWG No: SPTP-MB3-A-SFL-120-PC-d01 A1	
DO NOT SCALE DRAWING				This drawing remains the property of Tom Stoddart Pty Ltd & cannot be reproduced without prior permission.	
				A3	Sheet 1 of 22