

**INSTALLATION / OPERATION / MAINTENANCE
MANUAL**

(READ ALL INSTRUCTIONS BEFORE USE)



700/900

**BOILING PAN
(Electric)**

Models:

700 Series:
PEI705T

900 Series:
PEI910T / PEI915T

Page Intentionally Left Blank

1.0 Introduction

1.1 Your New Giorik Product	3
1.2 Australia and New Zealand Warranty	4
1.2.1 Warranty Period	
1.2.2 Warranty Registration	
1.3 General Precautions	5
1.3.1 General Warnings	
1.4 Setting Up Information	6
1.4.1 Handling	
1.4.2 Unpacking	
1.4.3 Disposal	

2.0 Specification

2.1 Specification	7
2.1.1 700 Series	
2.1.2 900 Series	
2.1.3 Rating Plate - Check Before Installation	
2.2 Technical Drawing	8
2.2.1 PEI705T	
2.2.2 PEI910T	
2.2.3 PEI915T	

3.0 Installation

3.1 Positioning	10
3.1.1 General Information	
3.1.2 Spacing	
3.2 Electrical Connection - Electric Models	11
3.2.1 Information	
3.2.2 Wiring	
3.3 Plumbing Connections	12
3.3.1 Information	
3.3.2 Reverse Osmosis	
3.3.3 Waste Connection	

4.0 Operation

4.1 Electric Operation	13
4.1.1 Controller Configuration	
4.1.2 Jacket Filling (Automatic)	
4.1.2 Operation	

5.0 Cleaning and Maintenance

5.1 Cleaning	14
5.1.1 Cleaning Schedule	
5.1.2 Materials Required	
5.1.3 General Information	
5.1.4 Corrosion Protection	
5.1.5 Surface Finish	
5.1.6 Cleaning Procedure (Daily)	
5.1.7 External Surfaces (Daily)	
5.1.8 Descaling the Unit (As required)	
5.2 Maintenance	16
5.2.1 Periodic Maintenance	
5.2.3 Troubleshooting	

1.1 Your New Giorik Product

Thank you for choosing this quality Giorik product.

All Giorik products are designed and manufactured to meet the needs of food service professionals. By caring for and maintaining this new Giorik product in accordance with these instructions, will provide many years of reliable service.

Stoddart is a wholly Australian owned company, which manufactures and/or distributes a comprehensive range of food service equipment for kitchens, food preparation and presentation. Stoddart products are manufactured and engineered to provide excellent results whilst offering value-for-money, ease-of-use and reliability.

Carefully read this instruction booklet, as it contains important advice for safe installation, operation and maintenance. Keep this booklet on hand in a safe place for future reference by other operators or users.

Disclaimer

The manufacturer/distributor cannot be held responsible or liable for any injuries or damages of any kind that occur to persons, units or others, due to abuse and misuse of this unit in regards to installation, removal, operation, servicing or maintenance, or lack of conformity with the instructions indicated in this documentation.

All units made by the manufacturer/distributor are delivered assembled, where possible, and ready to install. Any installation, removal, servicing, maintenance and access or removal of any parts, panels or safety barriers that is not permitted, does not comply in accordance to this documentation, or not performed by a **TRAINED AND AUTHORISED SPECIALIST** will result in the **IMMEDIATE LOSS OF THE WARRANTY.**

The manufacturer/distributor cannot be held responsible or liable for any unauthorised modifications or repairs. All modifications or repairs must be approved by the manufacturer/distributor in writing before initiating. All modifications or repairs performed to this unit must be performed at all times by a **TRAINED AND AUTHORISED SPECIALIST.**

**Stoddart design, manufacture & distribute Food Service Equipment (appliances) exclusively for the commercial market.
This appliance is not designed nor intended for household or domestic use and must not be used for this purpose.**

This product is intended for commercial use, and in line with Australian electrical safety standards the following warnings are provided:

- This product is not intended for use by persons (including children) with reduced physical, sensory or mental capabilities, or lack of experience and knowledge, unless they have been given supervision or instruction concerning the use of the product by a person responsible for their safety. Children should be supervised to ensure that they do not play with the product
- If the supply cord is damaged, it must be replaced by the manufacturer, its service agent or similarly qualified persons in order to avoid a hazard



Warranty & Registration

1.2 Australia and New Zealand Warranty

1.2.1 Warranty Period

All Stoddart manufactured and distributed products are covered by Stoddart's standard Australia and New Zealand Product Warranty (minimum 12 month on-site parts and labour, terms and conditions apply). Further to this standard warranty, certain products have access to an extended warranty. Full terms, conditions and exclusions can be found using the below Link/QR code.

1.2.2 Warranty Registration

To register your new product, Follow the below Link/QR code.

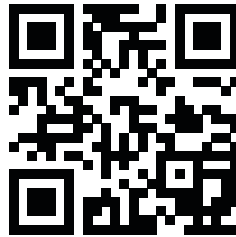

www.stoddart.com.au/warranty-information

1.3 General Precautions

When using any electrical unit, safety precautions must always be observed.

- All units **MUST** be installed according to the procedures stated in the installation section of this manual
- In the case of new personnel, training is to be provided before operating the equipment
- **DO NOT** use this unit for any other purpose than its intended use
- **DO NOT** store explosive substances such as aerosol cans with a flammable propellant in or near this unit
- Keep fingers out of “pinch point” areas
- Unit is not waterproof **DO NOT** use jet sprays, hoses or pour water over/on the exterior of the unit
- Only use this unit with voltage specified on the rating label
- **DO NOT** remove any cover panels that may be on the unit
- **DO NOT** use sharp objects to activate controls
- If any fault is detected, refer to troubleshooting
- The manufacturer declines any liability for damages to persons and/or things due to an improper/wrong and/or unreasonable use of the machine
- Only specifically trained/qualified Technicians (Stoddart, one of our service agents, or a similarly qualified persons) should carry out any and all repairs, maintenance and services

1.3.1 General Warnings



- DO NOT USE OR STORE FLAMMABLE MATERIALS IN OR NEAR THIS APPLIANCE
- DO NOT SPRAY AEROSOLS IN THE VICINITY OF THIS APPLIANCE WHILE IT IS IN OPERATION
- DO NOT MODIFY THIS APPLIANCE
- DO NOT PLACE ARTICLES ON OR AGAINST THIS APPLIANCE

The equipment complies with the essential requirements of the Low Voltage Directive 2006/95/EC and Electromagnetic Compatibility Directive 2004/108/EC

It meets the provisions of the following electrical standards:

- AS/NZS 60335.1

1.4 Setting Up Information

	IMPORTANT
	To be installed only by an authorised service person
	WARNING
	Improper installation, adjustments, alterations, service or maintenance can cause property damage, injury or death

1.4.1 Handling

- Use suitable means to move the unit;
 - For smaller items use two people
 - For large items a fork lift, pallet trolley or similar (the forks should reach completely beneath the pallet)

1.4.2 Unpacking

- Check the unit for damage before and after unpacking. If unit is damaged, contact the distributor and manufacturer
- Should any item have physical damage, report the details to the freight company and to the agent responsible for the dispatch within seven (7) days of receipt. No claims will be accepted or processed after this period
- Remove all protective plastic film, ties and packers before installing and operating
- Clean off any remaining residue from the interior/exterior of the unit using a clean cloth dampened with warm soapy water

1.4.3 Disposal

- At the end of the appliance's working life, make sure it is scrapped & components recycled properly
- Current environmental protection laws in the state/country of use must be observed
- Doors must be removed before disposal
- Power supply cable must be removed before disposal
- For further information on the recycling of this product, contact the local dealer/agent or the local body responsible for waste disposal

2.1 Specification

2.1.1 700 Series

700 Series - Electric	
Model	PEI705T
Description	Electric Boiling Pan 50L
Weight	120kg
Overall Height	1174mm
Overall Depth	815mm
Overall Width	800mm
Capacity	50 Litre
Electrical Connection	3Ø + N + E 415VAC / 50Hz / 10.8kW

2.1.2 900 Series

900 Series - Electric		
Model	PEI910T	PEI915T
Description	Electric Boiling Pan 100L	Electric Boiling Pan 150L
Weight	180kg	200kg
Overall Height	1174mm	1174mm
Overall Depth	1015mm	1015mm
Overall Width	800mm	800mm
Capacity	100 Litre	100 Litre
Electrical Connection	3Ø + N + E 415VAC / 50Hz / 22.7kW	3Ø + N + E 415VAC / 50Hz / 22.7kW

2.1.3 Rating Plate - Check Before Installation

The rating plate contains identification and technical data. See example below.

GIORIK		Imported by: STODDART www.stoddart.com.au	
Description: Giorik;900 Boiling Pan; Elec; 100 Ltr			
Electric Rating		Model No:	
V 415	HZ 50	PEI910T	
kW 22.7	Ph 3Ø + N + E		
		Serial No:	
		056963/07/21	

Fig.1.

2.2 Technical Drawing

2.2.1 PEI705T

Specifications:

Model	PEI705T
Description	Electric Boiling Pan 50L
Weight	120kg
Overall Height	1174mm
Overall Depth	815mm
Overall Width	800mm
Capacity	50 Litre
Electrical Connection	3Ø + N + E 415VAC / 50Hz / 10.8kW

Legend

- A Electrical Connection
- B Cold Water Connection 1/2" BSP
- C Filtered Water Connection 1/2" BSP
- D Drain Connection Ø38mm

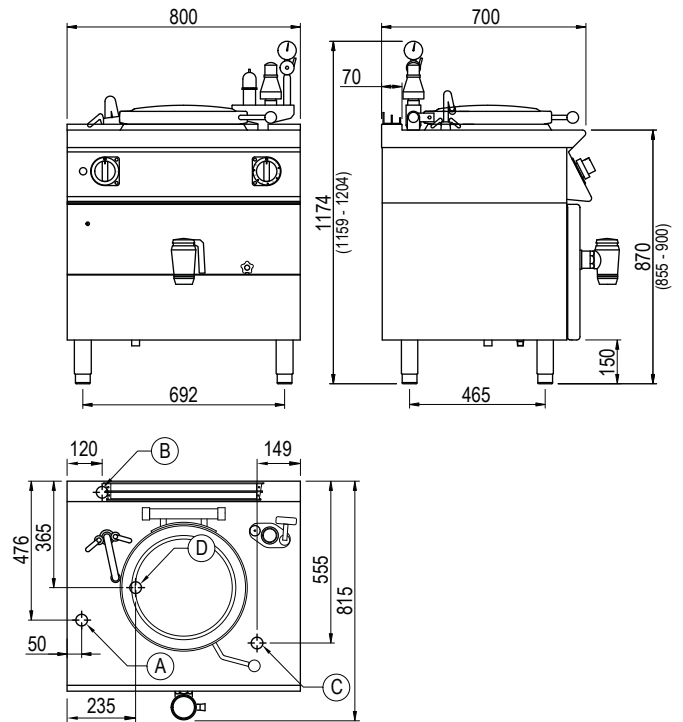

2.2.2 PEI910T

Specifications:

Model	PEI910T
Description	Electric Boiling Pan 100L
Weight	180kg
Overall Height	1174mm
Overall Depth	1015mm
Overall Width	800mm
Capacity	100 Litre
Electrical Connection	3Ø + N + E 415VAC / 50Hz / 22.7kW

Legend

- A Electrical Connection
- B Cold Water Connection 1/2" BSP
- C Filtered Water Connection 1/2" BSP
- D Drain Connection Ø38mm

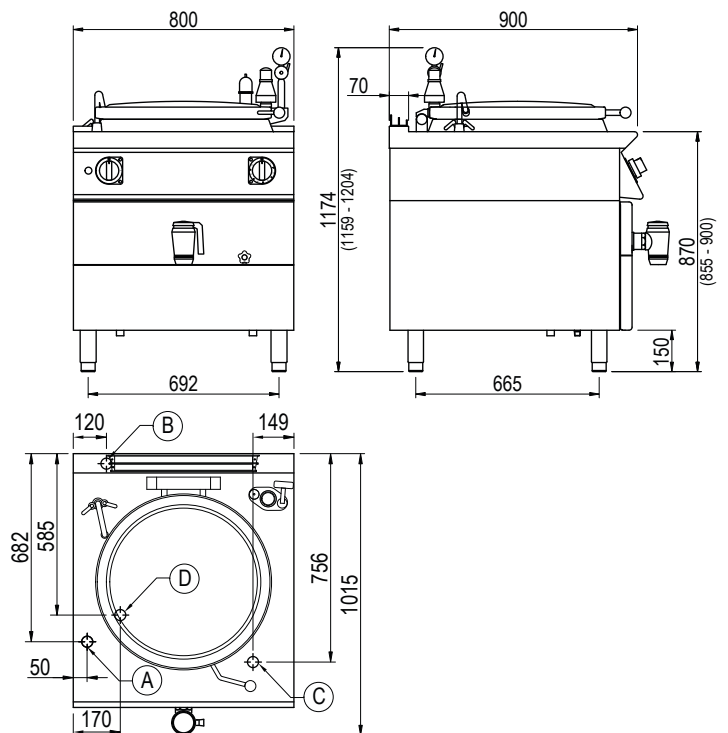

Due to continuous product research and development, the information contained herein is subject to change without notice.

2.2.3 PEI915T

Specifications:

Model	PEI915T
Description	Electric Boiling Pan 150L
Weight	200kg
Overall Height	1174mm
Overall Depth	1015mm
Overall Width	800mm
Capacity	100 Litre
Electrical Connection	3Ø + N + E 415VAC / 50Hz / 22.7kW

Legend

- A Electrical Connection
- B Cold Water Connection 1/2" BSP
- C Filtered Water Connection 1/2" BSP
- D Drain Connection Ø38mm

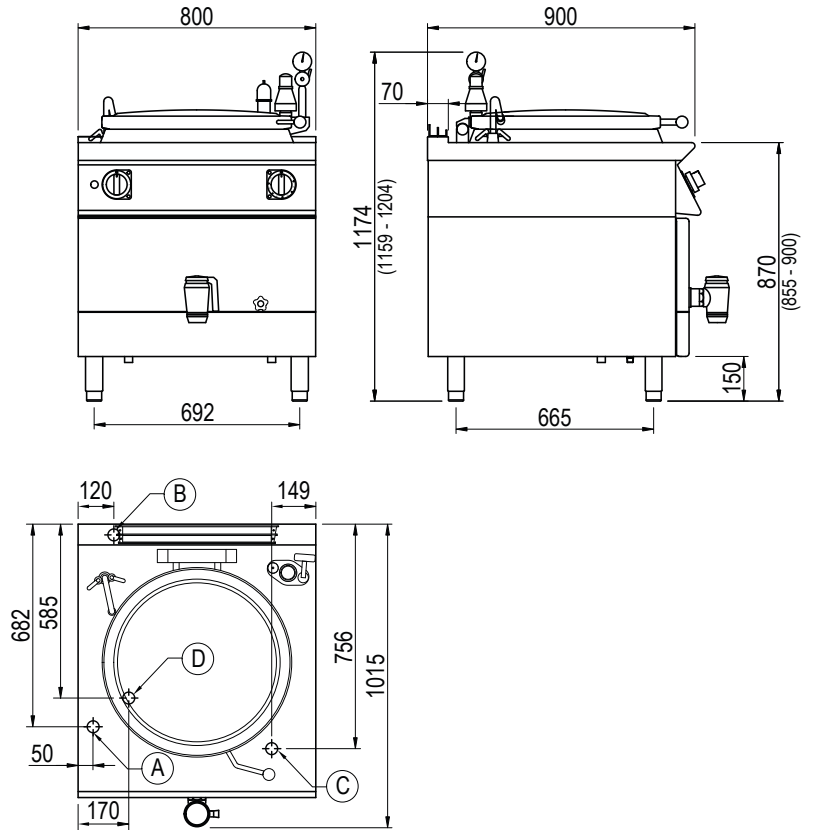

3.1 Positioning

	WARNING
	Improper installation, adjustments, alterations, service or maintenance can cause property damage, injury or death.

3.1.1 General Information

- Have a smooth, level floor which can bear the weight of the unit at full load
- Have a room temperature above +4°C with a maximum humidity of 70%;
- Comply with the regulations in force in terms of safety in the workplace and the systems;
- Not contain potentially explosive materials or substances;
- Be dedicated to food preparation
- Please consult national and local standards to ensure that your unit is positioned and ventilated in accordance with any existing requirements
- Do not allow cables or other items to rest/hang over the unit

3.1.2 Spacing

- Choose an area that is well ventilated and provides access for future maintenance
- Place the unit on a level stable work surface capable of supporting its weight
- Unit must be installed on a non combustible floor
- Unit must be installed on a fire proof base
- Do not position the unit in: wet areas, near heat and/or steam sources, near flammable substances
- The appliances are not designed for built-in installation
- **Spacing - Non-Combustible Walls:**
For installation next to non-combustible walls a minimum distance of 0mm from all sides

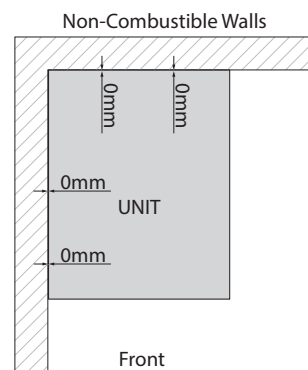



Fig.2.

- Please consult national and local standards to ensure that your unit is positioned in accordance with any existing requirement

3.2 Electrical Connection - Electric Models

3.2.1 Information

	WARNING
	<p>This unit must be installed in accordance with AS/NZS 60335.1</p> <p>Some procedures in this manual require the power to the equipment to be turned off and isolated. Turn the power OFF at the power point and unplug the power supply lead by the plug body. If the power point is not readily accessible turn the equipment off at the isolation switch or the circuit breaker in the switchboard. Attach a yellow "CAUTION-DO NOT OPERATE" tag. This must be performed where relevant unless the procedures specify otherwise.</p> <p>FAILURE TO DO SO MAY RESULT IN ELECTRIC SHOCK.</p>
	IMPORTANT
	<p>DO NOT pass the power cable near or allow it to come into contact with the rear of the appliance and/or flue of the cooker</p>

3.2.2 Wiring

Electrical Connection:

- A terminal block for on-site connection, by a licensed electrician will be supplied inside the service compartment of the unit and be indicated as:
 - 3Ø + N + E

3Ø N 415VAC 50Hz

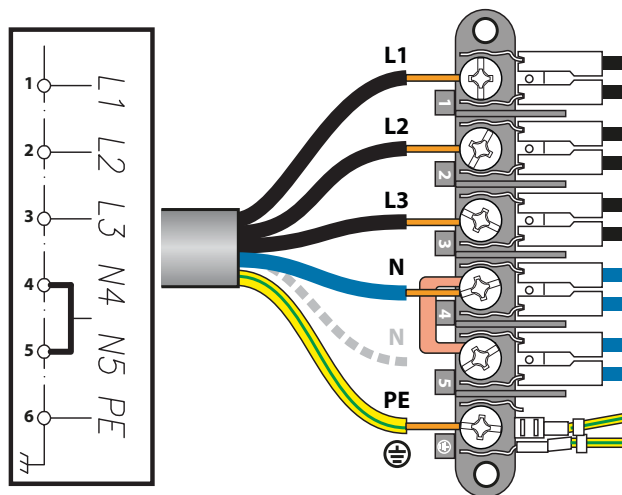

Fig.3.

Notes:

- The power cable should be dry and/or isolated from moisture or water
- DO NOT pass the power cable near or allow it to come into contact with the rear of the appliance and/or flue of the cooker

3.3 Plumbing Connections

3.3.1 Information

	IMPORTANT
	This unit must be installed in accordance with AS/NZS 3500.1 The unit must be installed with the supplied Water Filters and Pressure Limiting Valve

	IMPORTANT
	This unit must be connected and operated with a Reverse Osmosis (RO) system. Failure to operate without an RO system will void warranty.



3.3.2 Reverse Osmosis / Water Inlet Connection

For Reverse Osmosis installations, refer to the RO user-manual.

3.3.3 Waste Connection

This unit must be drained to a tundish. Pipes must be able to resist temperatures up to 100°C

4.1 Electric Operation

	WARNING
	<p>DO NOT use the boiling pan for any type of cooking without the Jacket being with water</p>
	WARNING
	<p>Hot surfaces! DO NOT TOUCH Contact with skin may cause burns</p>

4.1.1 Unit Overview

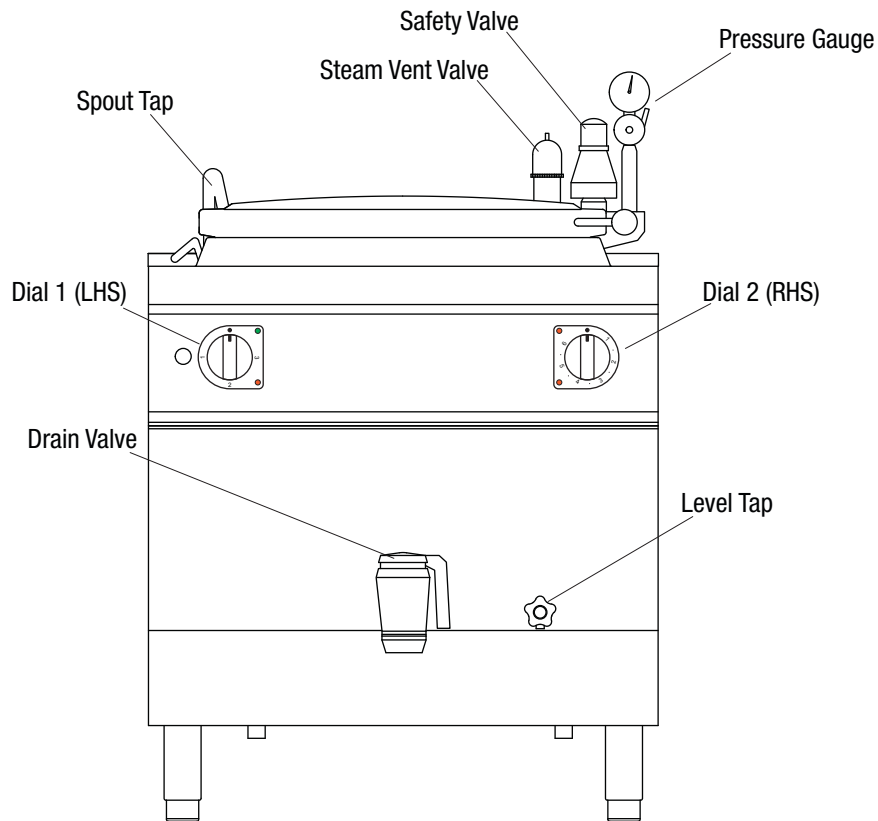







Fig.4.

4.1.2 Controller Configuration

Control Panel	
Symbol	Description
	Cooking Chamber Fill switch
Dial 1 (Left)	
	OFF
1	Automatic Jacket Fill
2	Half-Power Operation
3	Full-Power Operation
	Indicator Light 'A' (Power ON)
	Indicator Light 'B' (Automatic Jacket Filling)
Dial 2 (Right)	
1-6	Temperature Range 1 - 6 (1-5 = intermittent power, 6 = continuous power)
	Indicator Light 'C' (Half-Power Operation)
	Indicator Light 'D' (Full-Power Operation)

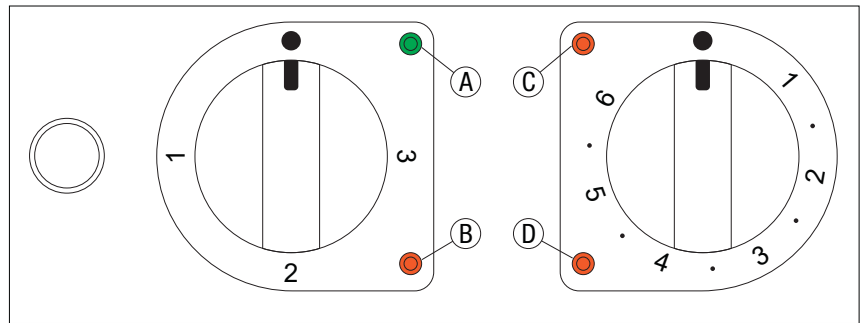

Fig.5.

4.1.3 Jacket Filling - Manual

1. Open the level tap located on the front panel of the boiling pan
2. fill the jacket with softened water up to the maximum level (signalled by the water spilling out from the tap)
3. Close the tap

4.1.4 Jacket Filling - Automatic

1. Open the level tap located on the front panel of the boiling pan
2. Rotate the Left Dial to position 1. The automatic jacket filling will start (Indicator light 'B'). the green indicator light will turn on indicating that the appliance is energised. automatic filling of the jacket will begin through the solenoid valve and the orange indicator light will turn on. To speed up this filling operation, press the black button next to the dial
3. Once the gap is filled (signalled by the water spilling out from the tap), close the tap

4.1.5 Operation

1. Add water to the kettle by turning on the spout tap to fill the kettle
2. Fill the kettle up to the maximum marking (located top back of the kettle), allow for volume of product to be cooked
3. After adding water, set the left dial to position 2 or 3;
4. Adjust the Right Dial to the required setting 1-6
5. To turn the unit off, turn both dials to the OFF position 
6. Empty the unit by opening the Drain Valve on the front of the unit

The pressure gauge of the valve body allows you to check the pressure in the gap. The safety valve is calibrated to 0.5 bar. When this value is exceeded, the safety valve automatically releases steam.

If an excessive amount of steam is coming out of the vent valve, the power must be reduced by adjusting the position of the right dial to the lowest numbers, or by selecting half power (pos.2) with the left dial.

5.1 Cleaning

5.1.1 Cleaning Schedule

- Daily cleaning is required for the appliance, to help maintain and prolong the appliance efficiency
- The appliance should be cleaned at the end of each service period
- **DO NOT USE:** Wire brushes, steel wool/sponges, scrapers or other abrasive materials
- Wait for the appliance to cool down before cleaning. Must be under 50°C

5.1.2 Materials Required

- Non Abrasive Cleaning pad
- Clean Sanitised Cloth
- Warm soapy water
- Appropriate PPE (Personal Protective Equipment)

5.1.3 General Information





- Cleaning is recommended for health and safety purposes and to prolong the life of the unit
- **DO NOT** use abrasive pads or cleaners on the stainless steel or any other metal parts of the unit
- **DO NOT** use industrial chemical cleaners, flammable cleaners, caustic based cleaners or bleaches and bleaching agents, as many will damage the metals and plastics used on this unit
- **DO NOT** remove any screws and/or panels for cleaning (unless directed)
- This unit is **NOT** waterproof, **DO NOT** hose, **DO NOT** pour water directly onto the unit, **DO NOT** immerse in water

5.1.4 Corrosion Protection

- Stainless steel exhibits good resistance to corrosion however, if not properly maintained stainless steel can rust and/or corrode
- Any sign of mild rust and/or corrosion should be thoroughly cleaned with warm soapy water and dried as soon as possible
- NEVER use abrasive pads or cleaners for cleaning
- All metal surfaces should be checked while cleaning for damage, scuffs or scrapes as these can lead to rust and further damage to the product
- Mild rust and/or corrosion can be treated with a commercial cleaning agent that contains citric/oxalic/nitric/phosphoric acid.
DO NOT use cleaning agents with chlorides or other harsh chemicals as this can cause corrosion.
After treatment, wash with warm (not hot) soapy water and dry thoroughly
- Thoroughly wipe the surfaces dry after cleaning. **DO NOT** let water pool on the unit. Check crevices and folds for pooling and dry thoroughly
- When using, ensure all liquids and moisture is cleaned up straight away.
Food liquids such as juices from vegetables and fruits should not be left on preparation surfaces
- **DO NOT** leave items on the stainless steel such as cutting boards, rubber mats and bottles

5.1.5 Surface Finish

- To protect the polished surface of the stainless steel, it should be dried using a clean dry soft cloth. A light oil can be applied to enhance the stainless steel surface, using a clean cloth apply the oil in the same direction as grained polished finish
- Some commercial stainless steel cleaners can leave residue or film on the metal; this may trap fine particles of food on the surface, thus deeming the surfaces not food safe

	<p style="text-align: center;">IMPORTANT</p> <p>Threaded fasteners can loosen in service. Regular inspection and adjustment should be carried out as required</p>		<p style="text-align: center;">WARNING</p> <p>This unit is NOT waterproof, do NOT hose. DO NOT pour water directly onto the unit. DO NOT immerse in water</p>
	<p style="text-align: center;">IMPORTANT</p> <p>Some commercial stainless steel cleaners leave residue or film on the metal that may entrap fine particles of food, deeming the surface not FOOD SAFE</p>		<p style="text-align: center;">WARNING</p> <p>Wait until the unit has cooled to a safe temperature before undertaking any cleaning or maintenance. Contact with hot surfaces can cause burns and serious injury</p>

5.1.6 Cleaning Procedure (Daily)

1. Isolate from the power supply
2. The unit **MUST** be drained before cleaning
3. Clean the unit with warm (not hot) soapy water and a sponge
4. After cleaning, turn the unit on and flush the unit with clean water
5. Thoroughly wipe the unit dry with a soft cloth. Do **NOT** let water pool in the unit, check crevices and folds

5.1.7 External Surfaces (Daily)

1. Isolate from the power supply
2. Wearing Personal Protective Equipment (PPE), apply Stainless Cleaner with the Cleaner pad to the external surfaces
3. Scrub any baked on soil with the cleaner pad in the same direction as grained polish
4. Wipe clean using a cloth dampened with clean warm water until all Stainless Cleaner and soil has been removed
5. Using a clean sanitised cloth, thoroughly wipe the stainless steel and metal parts dry. Do **NOT** let water pool on the unit. Check crevices and folds

5.1.8 Descaling the Unit (As required)

1. Descaling is recommended for health and safety purposes and to prolong the life of the unit
2. The unit **MUST** be descaled as required (visual inspection) to remove any scale build-up in the unit
3. To descale us vinegar or a descaling solution (The descaling solution should be used as per directions on the packaging)
4. Remove all food and pans from the unit before descaling
5. Ensure the unit is rinsed and thoroughly cleaned after descaling

5.2 Maintenance

	WARNING
	<p>Maintenance tasks MUST BE performed by qualified service people</p>

5.2.1 Periodic Maintenance

All controls and mechanical parts of the appliance **MUST BE** checked and adjusted periodically by a qualified service person. Contact the Stoddart service department to arrange a service

Maintenance / Inspections	Possible Causes	Frequency
Inspection of unit	Check for any damage, loose or missing components. Clean any soiled components	6 Months
Control Dials	Check Mechanical parts for any damage, loose or missing components	12 Months
Appliance Structure	Tighten any loose screws/bolts	12 Months
Electrical Connection	Check the power supply cable. Replace if there any visible signs of damage	12 Months

5.2.3 Troubleshooting

- If any faults/issues occur with the unit, follow the below troubleshooting procedures
- If the troubleshooting procedures do not correct the problem, contact the Stoddart Service Department

Problem	Possible Causes	Possible Corrective Action
ELECTRIC MODELS		
Unit not heating	Faulty electrical system contacts	Contact the Stoddart service department
	Unit not connected to power supply	Check the unit is plugged in and outlet is turned on
	On/Off dial not switched on	Check on/off dial is in the on position
	Thermostat Dial not turned on	Check the thermostat Dial is turned on
	Thermostat Dial is on	Check the power on indicator light is on
Unit not draining	Drain blockage	Check for visible blockage
	Faulty waste gate	Contact the Stoddart service department

Australia

Service / Spare Parts

Tel: 1300 307 289

Email: service@stoddart.com.au

Email: spares@stoddart.com.au

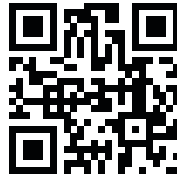

Service Request

www.stoddart.com.au

Australian Business Number: 16009690251

Sales

Tel: 1300 79 1954

Email: sales@stoddart.com.au

New Zealand

Service / Spare Parts

Tel: 0800 935 714

Email: service@stoddart.co.nz

Email: spares@stoddart.co.nz



Service Request

www.stoddart.co.nz

New Zealand Business Number: 6837694

Sales

Tel: 0800 79 1954

Email: sales@stoddart.co.nz

International

Service / Spare Parts

Tel: +617 3440 7600

Email: service@stoddart.com.au

Email: spares@stoddart.com.au

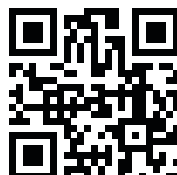

Service Request

www.stoddart.com.au

Sales

Tel: +617 3440 7600

Email: sales@stoddart.com.au