

Product Information:

- High quality 304 grade stainless steel tops
- 1.2mm thick, no. 4 finish
- 3mm zinalume core, marine grade protective paint
- 30mm square stainless steel tube, satin polished
- Adjustable stainless lug feet
- 6mm stainless steel flat bar servery supports, welded to frame, 2 fixing holes
- 2100 & 2400 length units supplied with 6 legs
- Supplied flat packed ready for assembly

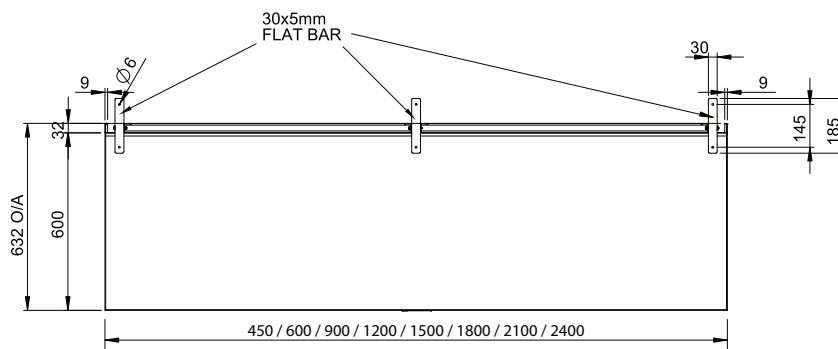

General Drawing:



PLAN

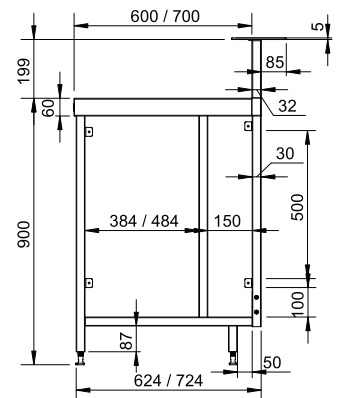

SIDE ELEVATION

Specifications

Product Code	W x D x H (mm)
SBM.0450	450 x 600 x 900
SBM.0600	600 x 600 x 900
SBM.0900	900 x 600 x 900
SBM.1200	1200 x 600 x 900
SBM.1500	1500 x 600 x 900
SBM.1800	1800 x 600 x 900
SBM.2100	2100 x 600 x 900
SBM.2400	2400 x 600 x 900
SBM.7.0450	450 x 700 x 900
SBM.7.0600	600 x 700 x 900
SBM.7.0900	900 x 700 x 900
SBM.7.1200	1200 x 700 x 900
SBM.7.1500	1500 x 700 x 900
SBM.7.1800	1800 x 700 x 900
SBM.7.2100	2100 x 700 x 900
SBM.7.2400	2400 x 700 x 900

Due to continuous product research and development, the information contained herein is subject to change without notice.

Revision: B - 29/07/2024 - 03

www.stoddart.com.au