

**KB101WT.xx.H**

**Premium Compact Combi Oven -**

Electric, 10 x 1/1 GN  
Recirculating Ventless Hood

**Product Information**

- Compact unit at only 519mm wide (30% less space than traditional ovens)
  - **Symbiotic Steam (patented)** innovative, heavy duty, highly efficient, dual boiler generation and steam injection oven
  - **Steam Tuner (patented)** exclusive feature allows tuning of saturated steam
  - **Meteo System (patented)** for precise control and saturation levels
  - Automatic descaling system for oven and boiler
  - Integrated recirculating cleaning via tablet, or inbuilt liquid detergent dispenser
  - Large 7" innovative touch screen interface
  - Over 120 pre-set cooking programs, 1,000+ additional programs - 9 phase memory
  - Automatic, adaptive cooking. Featuring rack control, regeneration, sous vide and smoking programs
  - Easy Service function, Recipe tuner, and Chef's note software
  - 6-speed inverter controlled fan for increased precision and reliability
  - LED lighting for superior cavity illumination
  - USB connection, HACCP
  - Supplied with multi-point core temperature probe, drain kit and advanced scale reduction filter
- The compact hood is certified as a performance solution for Australia and New Zealand by SEED Engineers in accordance with NCC-2022, AS1668.2-2012, and the UL710B Standard as the baseline
  - Featuring 4-stage filtration:
    - Washable Baffle and Mesh filter's, HEPA, and Carbon filter
  - Inbuilt demand based misting function (temperature controlled) Filtered air curtain at the front of with demand based airflow adjustment
- **24-month warranty (Terms and conditions apply)**



**Specifications**

<b>Standard Filter</b>	KB101WT.SF.H
<b>Reverse Osmosis</b>	KB101WT.RO.H
<b>W x D x H (mm)</b>	520 x 1198 x 1414*
*Dimensions do not include water filtration system	
<b>Weight</b>	161kg
<b>Capacity</b>	10 x 1/1 GN Pans
<b>Total Connected Load</b>	15.74kW / 25A circuit*
<b>Electrical Connection</b>	3Ø + N + E 415VAC / 50Hz L1 = 20.7A / L 2 = 22.8A / L3 = 18.3A
*Circuit required to be determined at installation by a qualified electrician.	
<b>Cold Water Connection</b>	3/4 BSP 150-350 kpa Min 10°C - Max 30°C
<b>Water Quality Requirements</b>	<b>Hardness</b> 60-100ppm <b>TDS</b> <100mg/L <b>Cl Chloride</b> <32mg/L

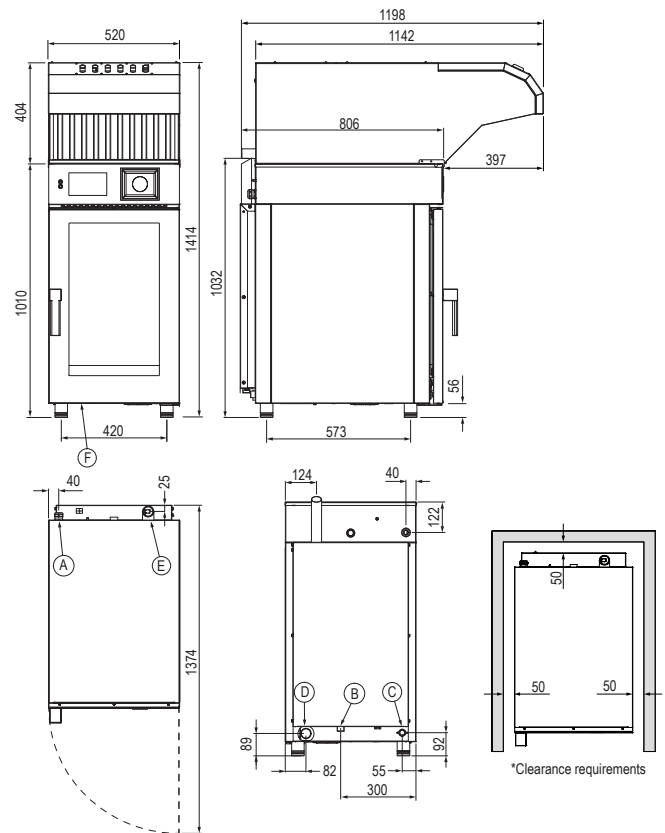

**Legend**

- A** Electrical Connection
- B** Steam Generation Water Inlet 3/4" BSP
- C** Wash System Water Inlet 3/4" BSP
- D** Drain Connection 40mm
- E** Humidity Vent
- F** Detergent & Rinse Aid Inlet

**Heat Source:** 500mm clearance from an external heat source is required in order to protect the oven control components. For clearances under 500mm, it is mandatory for Stoddart heat shields to be fitted while still maintaining a minimum clearance of 50mm to allow access to the unit. Failure to adhere to minimum clearances may void the oven warranty or add service costs due to lack of access.

**Non-Heat Source:** 50mm clearance from a non-heat source to allow access to the unit.