

**Steam
box**
EVOLUTION
R SERIES

**SPECIFICATION, INSTALLATION
& OPERATION MANUAL**
(READ ALL INSTRUCTIONS BEFORE USE)

R SERIES - COMBI OVENS



Electric Models:

SERE061WT / SERE062WT
SERE101WT / SERE102WT
SERE201WT / SERE202WT

Gas Models:

SERG061WT
SERG101WT / SERG102WT
SERG201WT / SERG202WT

Page Intentionally Left Blank

1.0 Introduction

1.1 Your New Giorik Product 4

1.2 Australia and New Zealand Warranty 5

 1.2.1 Warranty Period

 1.2.2 Warranty Registration

1.3 General Precautions 6

 1.3.1 General Warnings

2.0 Installation

2.1 Setting Up Information 7

 2.1.1 Handling

 2.1.2 Unpacking

 2.1.3 Disposal

 2.1.5 Stacked Installation

2.2 Positioning 8

 2.2.1 General Information

 2.2.2 Spacing

 2.2.3 Levelling 6/1GN, 6/2GN, 10/1GN, 10/2GN

 2.2.4 Levelling 20/1GN, 20/2GN

2.3 Electrical Connection 11

 2.3.1 Information

 2.3.2 Wiring

2.4 Gas Connection (Gas Models Only) 13

 2.4.1 Connecting the gas

 2.4.2 Rating Plate - Check Before Installation

 2.4.3 On-site Commissioning Adjustment

 2.4.4 Gas Conversion

 2.4.5 Ventilation/Extraction

2.5 Water Connection. 16

 2.5.1 Chloride Test

 2.5.2 Total Dissolved Solids (TDS) Test

 2.5.3 Filtration System

 2.5.4 Stoddart Standard Filter

 2.5.5 Stoddart Supplied Reverse Osmosis Filter

2.6 Drainage Connection 20

2.7 Liquid Detergent / Rinse Agent Connection 20

2.8 Oven Testing 21

 2.8.1 Gas Oven Operation

3.0 Specification

3.1 Technical Drawing 22

 3.1.1 SERE061WT

 3.1.2 SERE062WT

 3.1.3 SERE101WT

 3.1.4 SERE102WT

 3.1.5 SERE201WT

 3.1.6 SERE202WT

 3.1.7 SERG061WT

 3.1.8 SERG101WT

 3.1.9 SERG102WT

 3.1.10 SERG201WT

 3.1.11 SERG202WT

4.0 Operation

4.1 General Overview. 28

 4.1.1 Control Interface

 4.1.2 Cooking Screen Icons:

 4.1.3 Cooking Methods

4.2 Setup - Configuration Menu 30

 4.2.1 Date and Time / Language

 4.2.2 System Info

 4.2.3 Language

 4.2.4 Display Brightness

 4.2.5 Buzzer Volume

4.3 Manual Cooking 32

 4.3.1 Initial Settings

 4.3.2 Selecting The Cooking Method

 4.3.3 Selecting The Temperature

 4.3.4 Setting Preheating

 4.3.5 Time Setting:

 4.3.6 Core Probe:

 4.3.7 Delta T(ΔT):

 4.3.8 Fan Rotation Speed

 4.3.9 Manual Adjustment of Vent

 4.3.10 Humidity Percentage in Combi Mode

 4.3.11 Steam Phase

 4.3.12 Holding Phase

 4.3.13 Setting Multiple Cooking Phases (optional)

 4.3.14 Cooling Phase

 4.3.15 Smoking Phase

 4.3.16 To Delete a Phase

 4.3.17 Saving a Recipe

 4.3.18 Delete a Cooking Program

 Rename a Cooking Program

 4.3.20 Move a Cooking Program

4.4 Automatic Cooking 43

 4.4.1 Cooking Program Selection

 4.4.2 How To Use The Automatic Cooking Program

4.5 Special Automatic Cooking Programs. 44

 4.5.1 Rack Control - Manual Setting

 4.5.2 Rack Control - Menu Setting

 4.5.3 Rack Control - Easy Service

4.6 Special Functions. 47

 4.6.1 Cooling Of The Chamber

 4.6.2 Delayed Start

4.7 One Touch 48

4.8 Importing / Exporting Recipes and Log To USB 49

 4.8.1 Import / Export

4.9 Display LOG 50

4.10 HACCP Protocol 50

Contents continued on next page

Due to continuous product research and development, the information contained herein is subject to change without notice.

5.0 Cleaning and Maintenance	
5.1 Cleaning	51
5.1.1 General Information	
5.1.2 Corrosion Protection	
5.1.3 Surface Finish	
5.1.4 Cleaning and Maintenance Schedule	
5.1.5 Materials Required	
5.1.6 Cleaning External Surfaces	
5.1.7 Cleaning Internal Cavity	
5.1.8 Humidity Discharge	
5.1.9 Cleaning Glass Door	
5.1.10 Cleaning Internal Rack	
5.1.11 Control panel ventilation filter	
5.1.12 Rinse Head	
5.1.13 Inspect Door Seal	
5.1.14 Inspect Light Switch	
5.2 Automatic Cleaning	56
5.2.1 Wash Times 6 - 10 Tray	
5.2.2 Wash Times 20 - 40 Tray	
5.2.3 Wash Selection	
5.2.2 Start the Wash Program	
5.2.3 Stop the Wash Program	
5.3 Liquid Detergent Connection	58
5.4 Water Filtration	58
5.5 Troubleshooting	59
5.5.1 Common Problems	
5.5.2 Door Micro Switch	
5.5.3 Motor Thermal Breaker	
5.5.4 Safety Thermostat Of The Oven Chamber	
5.5.5 Technical Problems / Alarm Code	
5.6 Accessories and Consumables	61
5.6.1 Spare Parts	
5.7 Scheduled Maintenance Service History	62
5.6.1 Service Log	

1.0 Introduction

1.1 Your New Giorik Product

Thank you for choosing this quality Giorik product.

All Giorik products are designed and manufactured to meet the needs of food service professionals. By caring for and maintaining this new Giorik product in accordance with these instructions, will provide many years of reliable service.

Stoddart is a wholly Australian owned company, which manufactures and/or distributes a comprehensive range of food service equipment for kitchens, food preparation and presentation. Stoddart products are manufactured and engineered to provide excellent results whilst offering value-for-money, ease-of-use and reliability.

Carefully read this instruction booklet, as it contains important advice for safe installation, operation and maintenance. Keep this booklet on hand in a safe place for future reference by other operators or users.

Disclaimer

The manufacturer/distributor cannot be held responsible or liable for any injuries or damages of any kind that occur to persons, units or others, due to abuse and misuse of this unit in regards to installation, removal, operation, servicing or maintenance, or lack of conformity with the instructions indicated in this documentation.

All units made by the manufacturer/distributor are delivered assembled, where possible, and ready to install. Any installation, removal, servicing, maintenance and access or removal of any parts, panels or safety barriers that is not permitted, does not comply in accordance to this documentation, or not performed by a **TRAINED AND AUTHORISED SPECIALIST** will result in the **IMMEDIATE LOSS OF THE WARRANTY.**

The manufacturer/distributor cannot be held responsible or liable for any unauthorised modifications or repairs. All modifications or repairs must be approved by the manufacturer/distributor in writing before initiating. All modifications or repairs performed to this unit must be performed at all times by a **TRAINED AND AUTHORISED SPECIALIST.**

**Stoddart design, manufacture & distribute Food Service Equipment (appliances) exclusively for the commercial market.
This appliance is not designed nor intended for household or domestic use and must not be used for this purpose.**

This product is intended for commercial use, and in line with Australian electrical safety standards the following warnings are provided:

- This product is not intended for use by persons (including children) with reduced physical, sensory or mental capabilities, or lack of experience and knowledge, unless they have been given supervision or instruction concerning the use of the product by a person responsible for their safety. Children should be supervised to ensure that they do not play with the product
- If the supply cord is damaged, it must be replaced by the manufacturer, its service agent or similarly qualified persons in order to avoid a hazard



Warranty & Registration

1.2 Australia and New Zealand Warranty

1.2.1 Warranty Period

All Stoddart manufactured and distributed products are covered by Stoddart's standard Australia and New Zealand Product Warranty (minimum 12 month on-site parts and labour, terms and conditions apply). Further to this standard warranty, certain products have access to an extended warranty. Full terms, conditions and exclusions can be found using the below Link/QR code.

1.2.2 Warranty Registration

To register your new product, Follow the below Link/QR code.



Australia
[CLICK HERE](#)



New Zealand
[CLICK HERE](#)

1.3 General Precautions

When using any electrical unit, safety precautions must always be observed.

- All units **MUST** be installed according to the procedures stated in the installation section of this manual
- In the case of new personnel, training is to be provided before operating the equipment
- **DO NOT** use this unit for any other purpose than its intended use
- **DO NOT** store explosive substances such as aerosol cans with a flammable propellant in or near this unit
- Keep fingers out of “pinch point” areas
- Unit is not waterproof **DO NOT** use jet sprays, hoses or pour water over/on the exterior of the unit
- Only use this unit with voltage specified on the rating label
- **DO NOT** remove any cover panels that may be on the unit
- **DO NOT** use sharp objects to activate controls
- If any fault is detected, refer to troubleshooting
- The manufacturer declines any liability for damages to persons and/or things due to an improper/wrong and/or unreasonable use of the machine
- Only specifically trained/qualified Technicians (Stoddart, one of our service agents, or a similarly qualified persons) should carry out any and all repairs, maintenance and services

1.3.1 General Warnings

- DO NOT USE OR STORE FLAMMABLE MATERIALS IN OR NEAR THIS APPLIANCE
- DO NOT SPRAY AEROSOLS IN THE VICINITY OF THIS APPLIANCE WHILE IT IS IN OPERATION
- DO NOT MODIFY THIS APPLIANCE
- DO NOT PLACE ARTICLES ON OR AGAINST THIS APPLIANCE

The equipment complies with the essential requirements of the Low Voltage Directive 2006/95/EC and Electromagnetic Compatibility Directive 2004/108/EC

It meets the provisions of the following electrical, Watermark and Gas standards:

- AS/NZS 60335.1
- AS/NZS 60335.2.42
- AS/NZS 4563, AS/NZS 5601
- AS/NZS 1869
- WMTS-101

2.1 Setting Up Information

	IMPORTANT
	To be installed only by an authorised service technician

	WARNING
	Improper installation, adjustments, alterations, service or maintenance can cause property damage, injury or death

2.1.1 Handling

- Use suitable means to move the unit;
 - For smaller items use two people
 - For large items a fork lift, pallet trolley or similar (the forks should reach completely beneath the pallet)

2.1.2 Unpacking

- Check the unit for damage before and after unpacking. If unit is damaged, contact the distributor and manufacturer
- Should any item have physical damage, report the details to the freight company and to the agent responsible for the dispatch within seven (7) days of receipt. No claims will be accepted or processed after this period
- Remove all protective plastic film, ties and packers before installing and operating
- Clean off any remaining residue from the interior/exterior of the unit using a clean cloth dampened with warm soapy water

2.1.3 Disposal

- At the end of the appliance's working life, make sure it is scrapped & components recycled properly
- Current environmental protection laws in the state/country of use must be observed
- Doors must be removed before disposal
- Power supply cable must be removed before disposal
- For further information on the recycling of this product, contact the local dealer/agent or the local body responsible for waste disposal

2.1.5 Stacked Installation

	IMPORTANT
	FOR STACKED OVEN INSTALLATIONS, THIS MANUAL IS TO BE USED IN CONJUNCTION WITH THE STACKING INSTALLATION MANUAL (SUPPLIED WITH STACKING KIT)

2.2 Positioning

	IMPORTANT
	<p>Do not install unit under a bench. Under bench installation will void warranty</p>

2.2.1 General Information

- The oven must be installed under an extraction canopy that meets AS 1668.2.
- Have a smooth, level floor which can bear the weight of the appliance at full load
- Have a room temperature above +4°C with a maximum humidity of 70%;
- Comply with the regulations in force in terms of safety in the workplace and the systems;
- Not contain potentially explosive materials or substances;
- Be dedicated to food preparation. In addition, a gas-fired appliance requires, by law, rooms with a surface area and ventilation that are suitable for the power of the oven and that have a means of externally evacuating flue gases
- Please consult national and local standards to ensure that your unit is positioned and ventilated in accordance with any existing requirements
- Do not allow cables or other items to rest/hang over the exhaust vents
- Do not install unit under a bench
- No equipment is to be installed/placed on the Service compartment (top of oven) excluding stacked applications using a Stoddart stacking kit and/or Stoddart Recirculating Hood. The service compartment must be easily accessible. Failure to adhere may add service costs due to lack of access.

2.2.2 Spacing

To allow access to service panel and protection of the control components, the service side of the Combi oven must have the following minimum clearances:

Service compartment Heat Source

500mm clearance from another heat source, in order to protect the oven control components and allow access to the service panel. For distances under 500mm, it is mandatory for Stoddart heat shields to be fitted (for a minimum distance of 300mm from the service compartment). Failure to adhere to minimum clearances may void the oven warranty and add service costs due to lack of access

Service compartment Non-Heat Source

300mm clearance from a non-heat source to allow access to the service panel. Any distance under 300mm, will add service costs due to lack of access

Heat Source

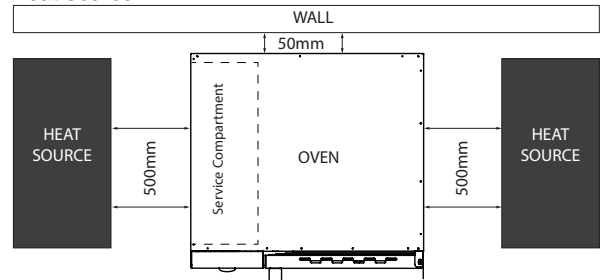

Heat Source With Heat Shield

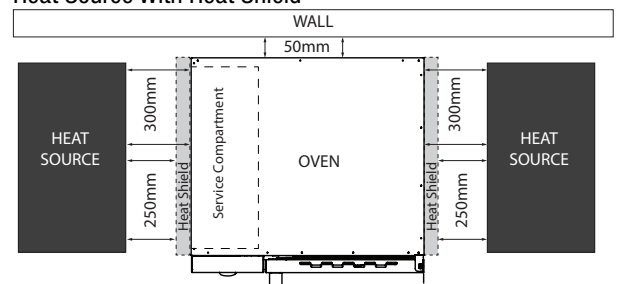

Non - Heat Source

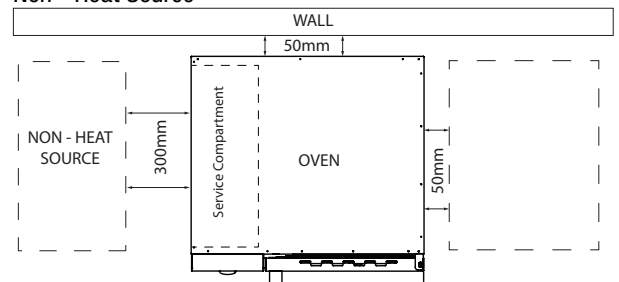

2.2.3 Levelling 6/1GN, 6/2GN, 10/1GN, 10/2GN

- Using a spirit level, ensure that the Combi oven is level. Adjust the foot height to level Combi oven
- If using a stand, level the stand by adjusting the feet, then level the Combi oven

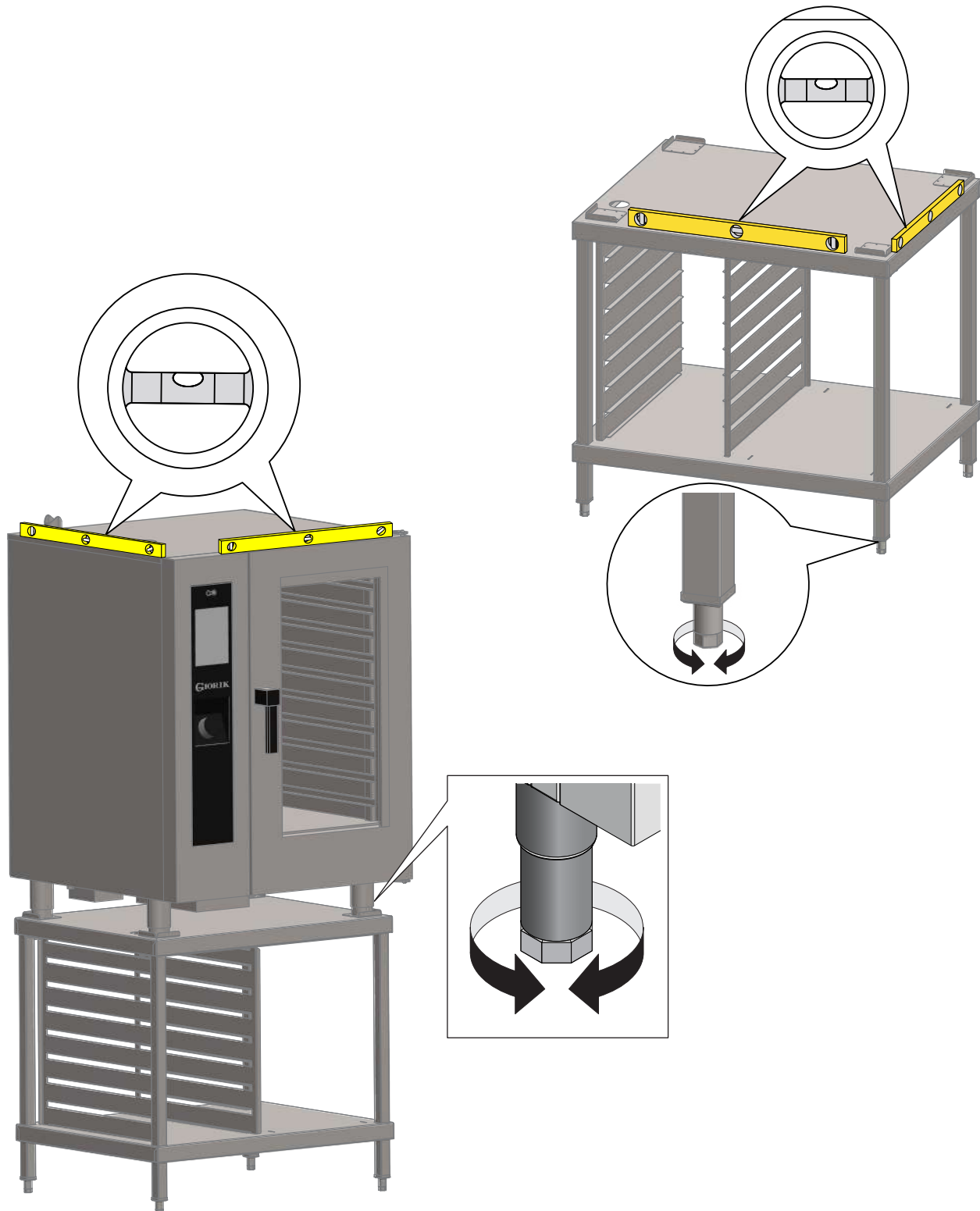

2.0 Installation

2.2.4 Levelling 20/1GN, 20/2GN

- For improved safety and stability, the 20 tray oven can be fastened to the ground
- Remove the two screws that secure the rear foot to the frame
- Position the locking brackets and secure to the oven using the previously removed screws
- Attach the bracket foot to the locking bracket, let bracket foot sit on ground, then tighten
- Ensure that the oven is in the correct installation position, mark the hole locations of the bracket on the floor
- Move the oven forward, drill the marked holes (6mm hole) and insert a suitable fixing plug
- Push the oven back into position aligning the bracket with the drilled holes. Secure the bracket to the ground with fixing screws

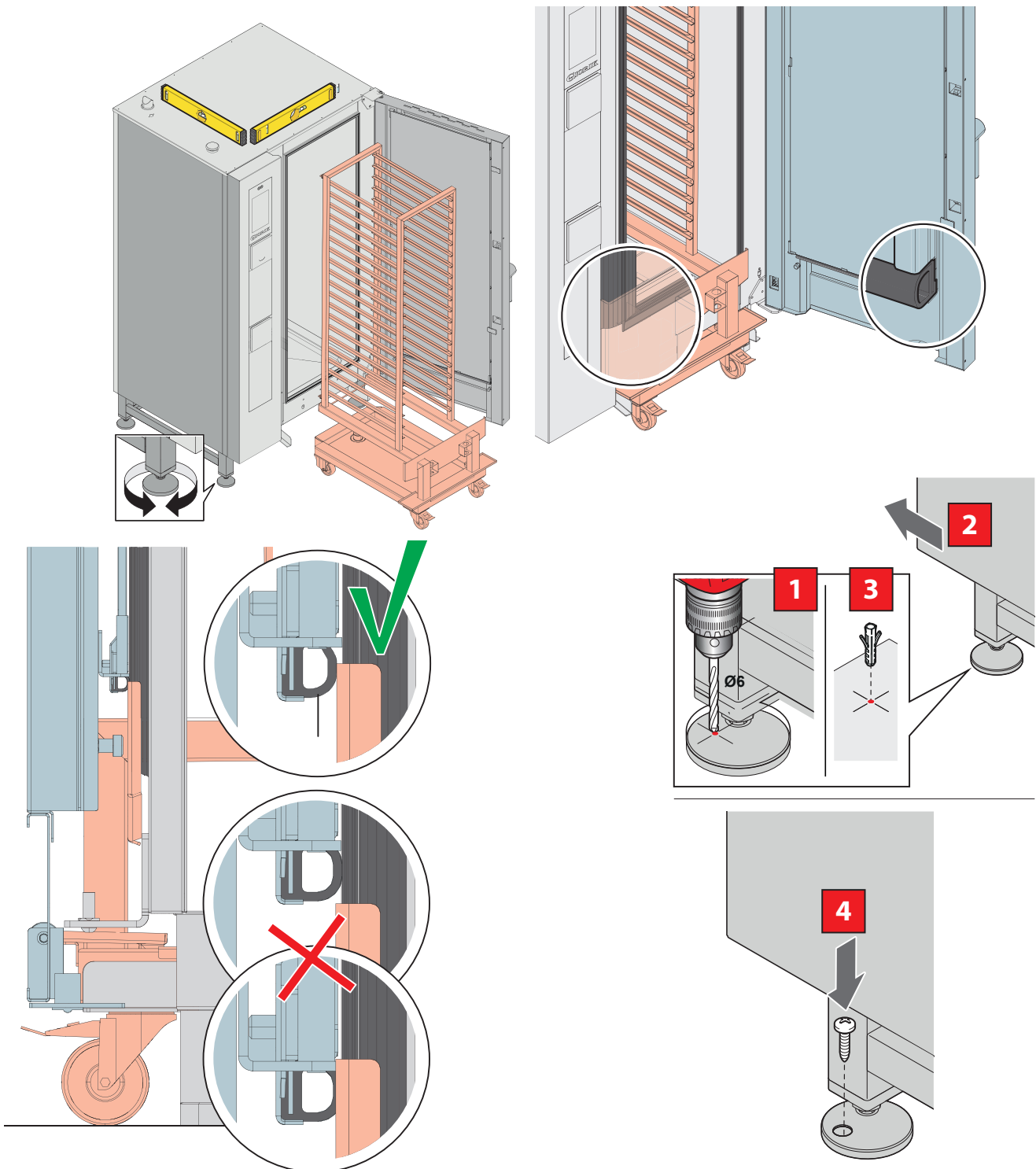

Due to continuous product research and development, the information contained herein is subject to change without notice.

2.3 Electrical Connection

2.3.1 Information

	WARNING
	<p>This unit must be installed in accordance with local electrical regulations/requirements. Some procedures in this manual require the power to the equipment to be turned off and isolated. Turn the power OFF at the power point and unplug the power supply lead by the plug body. If the power point is not readily accessible turn the equipment off at the isolation switch or the circuit breaker in the switchboard. Attach a yellow “CAUTION-DO NOT OPERATE” tag. This must be performed where relevant unless the procedures specify otherwise.</p> <p style="text-align: center;">FAILURE TO DO SO MAY RESULT IN ELECTRIC SHOCK.</p>

Single Phase GAS Units:

- Supplied and fitted with an appropriately rated plug and lead

Three Phase Units:

- A terminal block for on-site connection, by a licensed electrician located inside the service compartment of the unit, indicated as:
- 3Ø + N + E

Notes:

- If the supply cord is damaged, it must be replaced by the manufacturer, its service agent or similarly qualified persons in order to avoid a hazard. Please contact Stoddart for parts and we will advise how to do this in order to avoid any electrical hazard
- The power cable should be dry and/or isolated from moisture or water

2.0 Installation

2.3.2 Wiring

1. Remove service compartment cover
2. Connect electrical wiring, following the below wiring diagram
After connecting wires, use a multimeter to check:
 - There is no electrical dispersion between the phases and the earth
 - For electrical continuity between the external casing and the mains earth
3. Reinstall service compartment cover
4. Secure wiring cable by fastening the cable gland nut

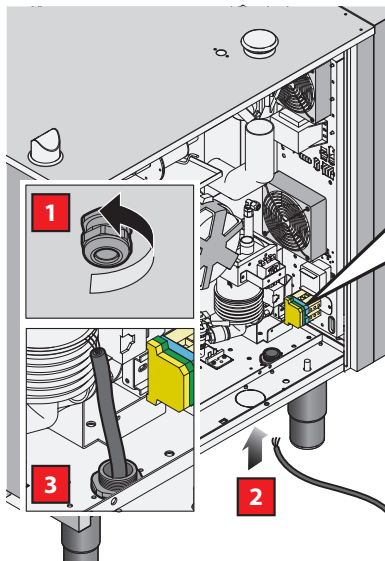
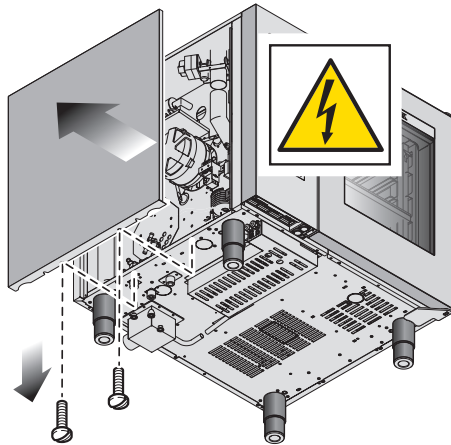

ELECTRIC ONLY

L1 Phases
L2 Phases
L3 Phases
N Neutral
 Yellow/green: earth

GAS ONLY

L Phases
N Neutral
 Yellow/green: earth

Model	SERE061WT	SERE062WT	SERE101WT	SERE102WT	SERE201WT	SERE202WT
Weight	107	170	140	190	260	340
Power (kW)	3Ø + N + E 415VAC / 50Hz / 11.3kW	3Ø + N + E 415VAC / 50Hz / 22.2kW	3Ø + N + E 415VAC / 50Hz / 16.8kW	3Ø + N + E 415VAC / 50Hz / 25.8kW	3Ø + N + E 415VAC / 50Hz / 33.4kW	3Ø + N + E 415VAC / 50Hz / 51.6kW
Model	SERG061WT	---	SERG101WT	SERG102WT	SERG201WT	SERG202WT
Weight	142	---	178	250	300	400
Power (kW)	1Ø + N + E 230VAC / 50Hz / 0.4kW 10A Plug and Lead	---	1Ø + N + E 230VAC / 50Hz / 0.5kW 10A Plug and Lead	1Ø + N + E 230VAC / 50Hz / 0.6kW 10A Plug and Lead	1Ø + N + E 230VAC / 50Hz / 0.8kW 10A Plug and Lead	1Ø + N + E 230VAC / 50Hz / 1.3kW 10A Plug and Lead

Due to continuous product research and development, the information contained herein is subject to change without notice.

2.4 Gas Connection (Gas Models Only)

	WARNING
	<p>This unit must be installed by an authorised person in accordance with this instruction manual, AS/NZS 5601 – Gas installations (installation and pipe sizing), local gas fitting regulations, local electrical regulations, local water regulations, local health regulations, Building Code of Australia and any other government authority.</p>

2.4.1 Connecting the gas

Must use restraining cable if oven is installed with flexible gas hose connection and Hose assemblies for use with cooking appliances shall be certified as conforming to AS/NZS 1869 and be Class B or Class D. Quick connect devices if provided, shall be certified to AG 212 (to be AS 4627).

The oven is calibrated originally for operation with the type of gas specified on placing the order. The type of gas for which the oven is adjusted is given on the technical Installation prescriptions The oven installation and commissioning operations must be performed by qualified staff only in compliance with rules and regulations in force. The gas, electrical connections and the installation location of the oven must be in compliance with the regulations and the standards in force.

Model Number	Gas Type	Nozzle (mm)	Nozzle Type	Test Point Pressure (kPa)	Total (MJ/h)	Air/Gas Ratio Adjustment (Turn Clockwise to fully close)
SERG061WT	Natural Gas	5.0mm	Disc	1.0	43.2	5 Turns (From Closed)
SERG101WT		5.0mm	Disc		68.4	4 Turns (From Closed)
SERG102WT		4.6mm	Cylindrical		97.2	5 Turns (From Closed)
SERG201WT - Upper Burner		5.0mm	Disc		64.8	4 Turns (From Closed)
SERG201WT - Lower Burner		5.0mm	Disc		64.8	4 Turns (From Closed)
SERG202WT - Upper Burner		4.6mm	Cylindrical		97.2	5 Turns (From Closed)
SERG202WT - Lower Burner		4.6mm	Cylindrical		97.2	5 Turns (From Closed)
SERG061WT		Universal LPG	3.8mm		Cylindrical	2.70
SERG101WT	3.8mm		Cylindrical	68.4	5 Turns (From Closed)	
SERG102WT	3.8mm		Cylindrical	97.2	5 Turns (From Closed)	
SERG201WT - Upper Burner	3.8mm		Cylindrical	64.8	5 Turns (From Closed)	
SERG201WT - Lower Burner	3.8mm		Cylindrical	64.8	5 Turns (From Closed)	
SERG202WT - Upper Burner	3.8mm		Cylindrical	97.2	5 Turns (From Closed)	
SERG202WT - Lower Burner	3.8mm		Cylindrical	97.2	5 Turns (From Closed)	

Note that the air necessary for combustion of the burners is 2 m³/h per kW of power installed. This appliance is suitable for connection with rigid pipe or flexible hose. The isolating manual shut-off valve connection point must be accessible when the appliance is installed.

Natural Gas: the supplied regulator must be fitted to the appliance inlet connection. Gas pressure must be adjusted to 1.00 kPa when the burner is operating at high flame, the appliance test point is located on the regulator.

Universal LPG: the supplied regulator must be fitted to the appliance inlet connection. Gas pressure must be adjusted to 2.70 kPa when the burner is operating at high flame, the appliance test point is located on the regulator.

2.4.2 Rating Plate - Check Before Installation

Confirm that this unit has been tested and approved for the type of gas used at the installation location.

		Imported by: STODDART www.stoddart.com.au
Description: Giorik; Steambox; COMBI OVEN GAS WITH BOILER 10 GN1/1		
Gas Approval No. 	Gas Injector 5.0mm for Natural Gas 3.8mm for Universal LPG	Model No: SERG101WT
Factory set gas type <input type="checkbox"/> Natural Gas <input type="checkbox"/> Universal LPG	Total gas consumption 68.4 MJ/h	Test Point Pressure 1.00 kPa Natural Gas 2.70 kPa Universal LPG
Global-Mark.com.au® ID: GAS-105480-003	Electric Rating V 230 HZ 50 kW 1.5 Ph 1	Serial No: 002787/03/20
		

Rating Plate example

Due to continuous product research and development, the information contained herein is subject to change without notice.

2.4.3 On-site Commissioning Adjustment

- Ensure the regulator supplied is fitted and the correct inlet gas pressure is adjusted
- From the specification table listed on the previous page please adjust the RQ screw the nominated turns from closed
- Once the unit has been installed and all installation instructions followed please turn the unit on
 - Ensure the cavity is empty of all packaging items

Adjust RQ screw as indicated in the table (Page 9)



Gas Test Procedure:

- Press "Settings"
- Press "Service"
- Press "Advanced Services"
- Type the password 156 then press Enter to confirm
- Press "Gas Test"
- The gas test must be carried out with the door open
- Phase 1 - Burner Off. Press "Forward" to begin the gas test procedure
- Phase 2 - Burner ignition
- Phase 3 - Minimum / Maximum power. Press "Back/Forward" to toggle between Minimum / Maximum.
- Press forward when on the Maximum Speed screen to end the procedure

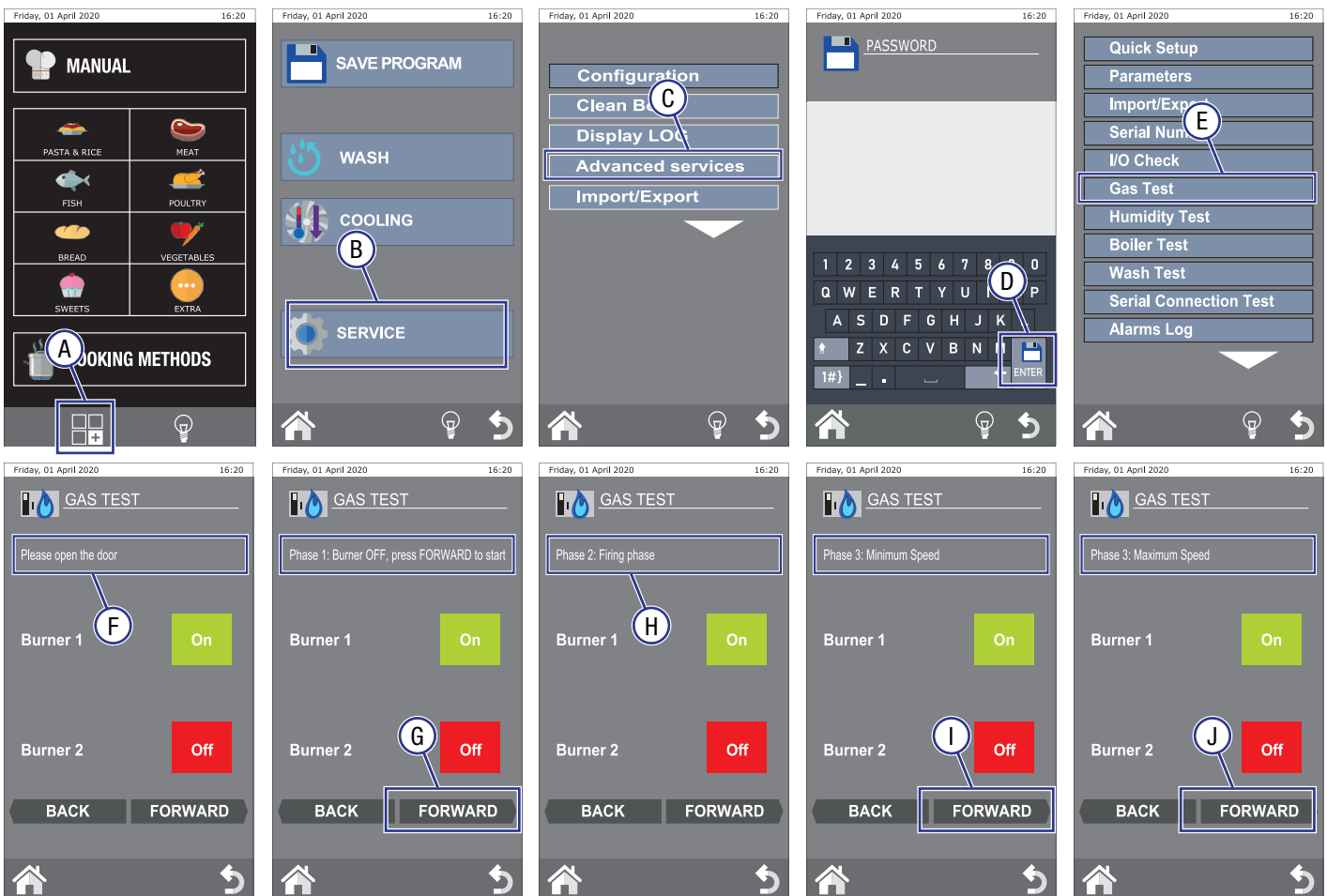

Due to continuous product research and development, the information contained herein is subject to change without notice.

For connection using a flexible hose assembly, the flexible hose assembly must be certified to AS/NZS 1869 class B or D, be of appropriate internal diameter for the total gas consumption, be kept as short as possible (not exceeding 1200mm), must not be in contact with the floor or any hot or sharp surfaces. The hose assembly must not be subject to strain, abrasion, kinking or deformation.

A restraining device must be fitted to restrict the appliance movement to no more than 80% of the gas hose length.

Annual service by an authorised person is recommended, or if any of the following conditions are noticed; incomplete ignition, appreciable yellow tipping, carbon deposition, lifting, floating, lighting back or objectionable odour.

2.4.4 Gas Conversion

- Please ensure the unit is the correct gas type for the supplied gas. Gas type is nominated on the appliances rating plate
- Should the appliance require converting to an alternative gas type please contact Stoddart as this must be carried out by an Authorised Service Technician

2.4.5 Ventilation/Extraction

In compliance with the installation regulations, the ovens must be used in premises suitable for the evacuation of combustion products.

The oven must be installed under an extraction canopy that meets AS 1668.2. and in accordance with all local council regulations.

When the appliance is installed under the extraction hood, check that the following indications are respected:

- The volume extracted must be higher than that of the flue gases generated (see current regulation)
- The material with which the hood filter is made must resist the temperature of the flue gases which, on exiting the appliance, can reach 300°C
- The end part of the appliance flue pipe must be positioned inside the base perimeter projection of the hood

2.5 Water Connection

IMPORTANT

Selection of the correct water filtration system to suit local water conditions is **CRITICAL**. Failure to install the correct system according to the following guidelines will void warranty.

2.5.1 Chloride Test

1. Remove Titrator from bottle and replace bottle cap immediately
2. Insert lower end of the Titrator into water to be tested (approx 20mm of water). DO NOT allow water to touch yellow completion band at top of Titrator
3. Allow water to completely saturate the wick of Titrator. Reaction is complete when yellow band turns dark
4. Note where the white chloride peak falls on the scale. This represents the unit value
5. Refer to the table to convert the Titrator units into salt concentration

* Readings greater than 1.4 (32PPM) require a Reverse Osmosis Unit to be installed

* Readings less than 1.4 (32PPM) require the Total dissolved solids (TDS) be tested

ppm(mg/L)			ppm(mg/L)		
Units	%NaCl	Cl	Units	%NaCl	Cl
1.4	0.005	32	4.6	0.032	196
1.6	0.006	39	4.8	0.035	212
1.8	0.007	45	5.0	0.038	229
2.0	0.009	53	5.2	0.041	248
2.2	0.010	60	5.4	0.044	267
2.4	0.011	68	5.6	0.048	288
2.6	0.013	77	5.8	0.051	311
2.8	0.014	86	6.0	0.055	335
3.0	0.016	95	6.2	0.060	361
3.2	0.017	106	6.4	0.064	389
3.4	0.019	116	6.6	0.069	419
3.6	0.021	128	6.8	0.074	452
3.8	0.023	140	7.0	0.080	487
4.0	0.025	152	7.2	0.087	525
4.2	0.027	166	7.4	0.093	567
4.4	0.030	180	7.6	0.101	613

2.5.2 Total Dissolved Solids (TDS) Test

1. Remove the cover from the TDS meter, turn on by pressing the On/Off button. The display should read 000
2. Insert lower end of the TDS meter into water to be tested (approx 20mm of water). DO NOT completely submerge
3. Wait 5-10 seconds
4. The number displayed on meter is the TDS (Total Dissolved Solids) of the water expressed in PPM (parts per million) e.g. TDS = 70PPM
 - Contact Stoddart if reading is lower than 20ppm
5. When finished, turn the TDS meter off

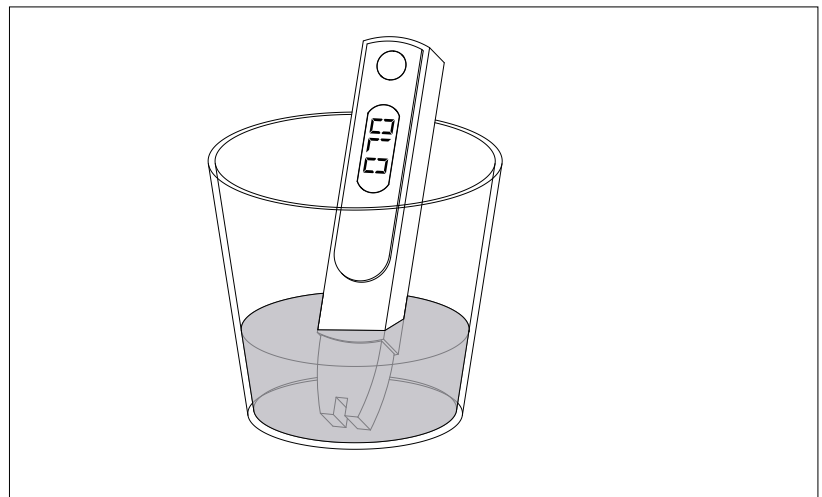

2.5.3 Filtration System

- After testing the water supply quality, use the below chart to determine the water filter requirements
- Only Stoddart supplied filter systems can be used

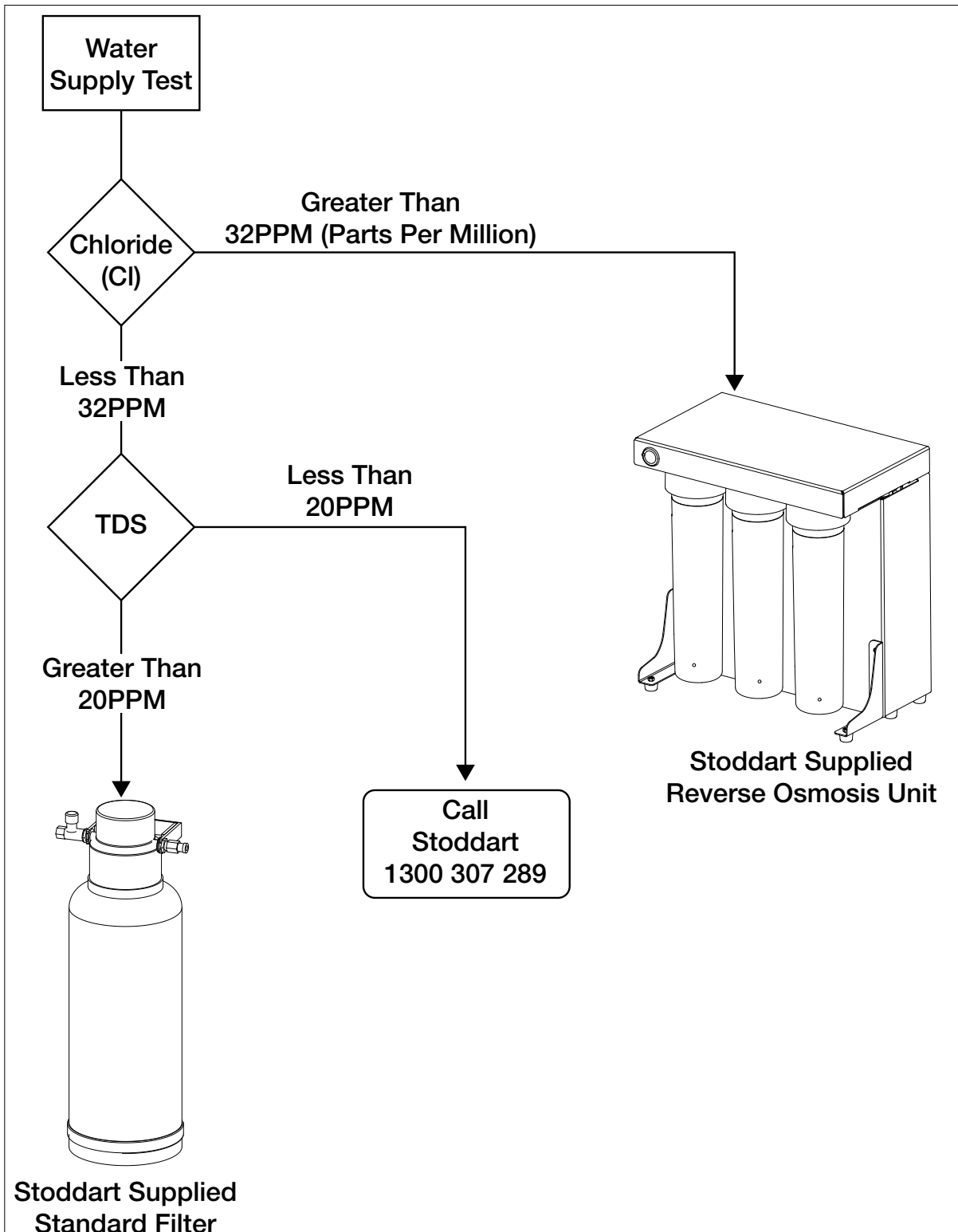

2.5.4 Stoddart Standard Filter

IMPORTANT

This oven must be installed in accordance with the Plumbing Code of Australia (PCA)
The Oven must be installed with the supplied Dual Check Valve, Water Filter and Pressure Limiting Valves

- Water connections are labelled on the oven
- Isolation valve must be installed at the water supply outlet
- **Water Temperature:**
Cold water connection - Min 10°C, Max 30°C
- **Steam Generation:**
The Combi oven requires filtered water supplied to its steam generation system. Water pressure must be 150-300 kPa at oven connection. This is controlled with the supplied PLV
- **Wash System:**
The Combi oven requires unfiltered water supplied to its wash system.
Water pressure must be 150-300 kPa at oven connection. This is controlled with the supplied PLV
- Refer to the Stoddart Standard Filter user manual for filter setup

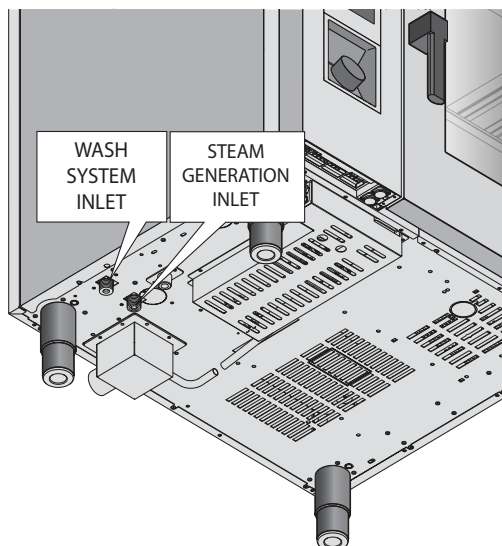

COLD WATER CONNECTION WITH ISOLATION VALVE (EXISTING CONNECTION)

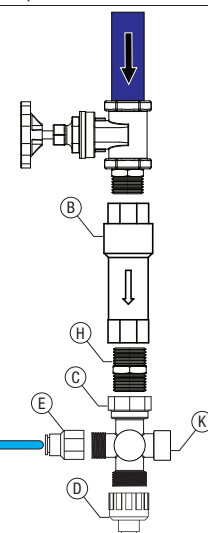

Supplied Components:

Item	Description	Oven Plumbing Kit	Stoddart Standard filter Kit	Total Qty.
A	Stoddart Standard Filter	---	1	1
B	Dual Check Valve	1	---	1
C	Four Way Manifold	1	---	1
D	3/4" Bsp To 3/8" Tube Connector	2	1	3
E	1/2" Bsp To 3/8" Tube Connector	---	1	1
F	3/8" John Guest Stem Elbow	2	---	2
G	Pressure Limiting Valve 300-350 Kpa	1	1	1
H	Nipple, 3/4" Male	1	---	1
I	3m 3/8 Tube (Water)	1	---	1
J	John Guest Locking Clip	5	6	11
K	Spare outlet (Hand Shower)	1	---	1

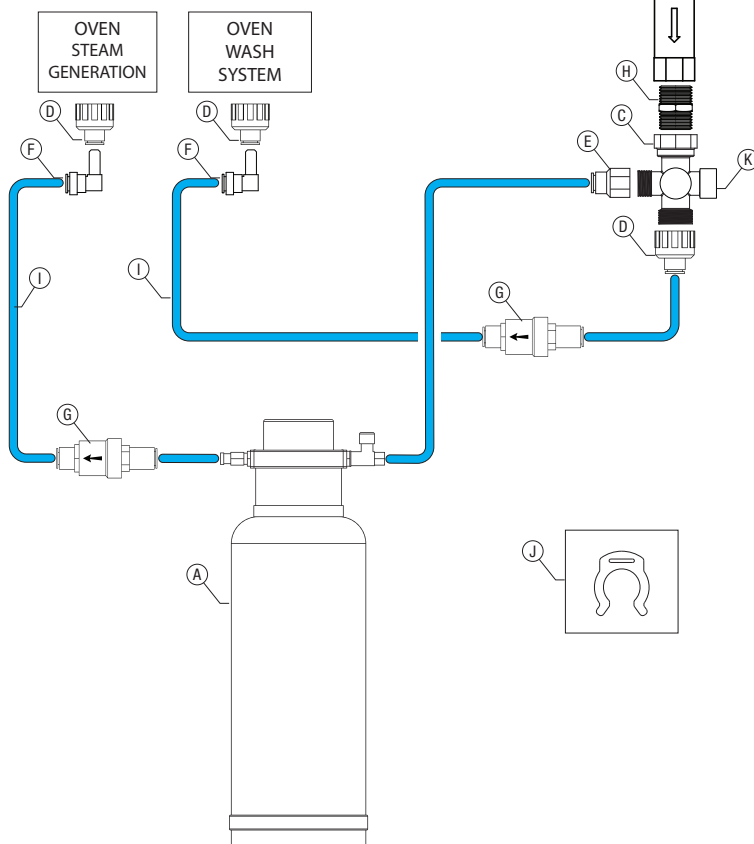

Due to continuous product research and development, the information contained herein is subject to change without notice.

2.5.5 Stoddart Supplied Reverse Osmosis Filter

IMPORTANT



This oven must be installed in accordance with the
Plumbing Code of Australia (PCA)
The Oven must be installed with the supplied Dual Check Valve,
Water Filter and Pressure Limiting Valves

- Water connections are labelled on the oven
- Isolation valve must be installed at the water supply outlet
- **Water Temperature:**
Cold water connection 15°C ± 5°C
- **Steam Generation:**
The Combi oven requires filtered water supplied to its steam generation system. Water pressure must be 150-300 kPa at oven connection. This is controlled with the Stoddart RO system
- **Wash System:**
The Combi oven requires unfiltered water supplied to its wash system. Water pressure must be 150-300 kPa at oven connection. This is controlled with the supplied PLV
- Refer to the Stoddart supplied RO user manual for filter setup

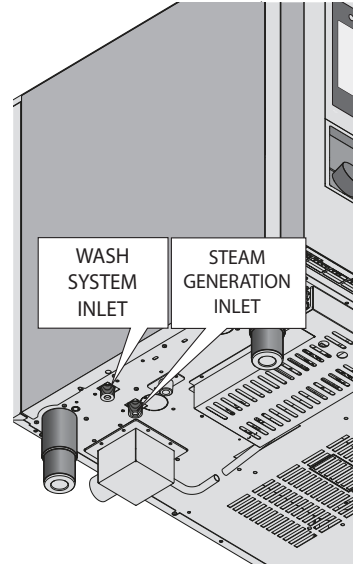

Item	Description	Supplied with Oven	Supplied with RO Kit	Total Qty.
A	Dual Check Valve	1	---	1
B	Four Way Manifold	1	---	1
C	3/4" Bsp To 3/8" Tube Connector	---	3	3
D	1/2" Bsp To 3/8" Tube Connector	---	1	1
E	3/8" John Guest Stem Elbow	---	2	2
F	Pressure Limiting Valve 300-350 Kpa	---	1	1
G	Pressure Limiting Valve 350-600 Kpa	---	1	1
H	Nipple, 3/4" Male	1	---	1
I	Blue 3/8 Tube 'Filtered Water' (to be cut to length)	---	1	1
J	White 3/8 Tube 'Unfiltered Water' (to be cut to length)	---	1	1
K	Red 1/4 Tube 'Drain' (to be cut to length)	---	1	1
L	3/8" John Guest Three Way Manifold (For filter flushing)	---	1	1
M	John Guest Locking Clip	---	12	12
N	Spare outlet (Hand Shower)	1	---	1

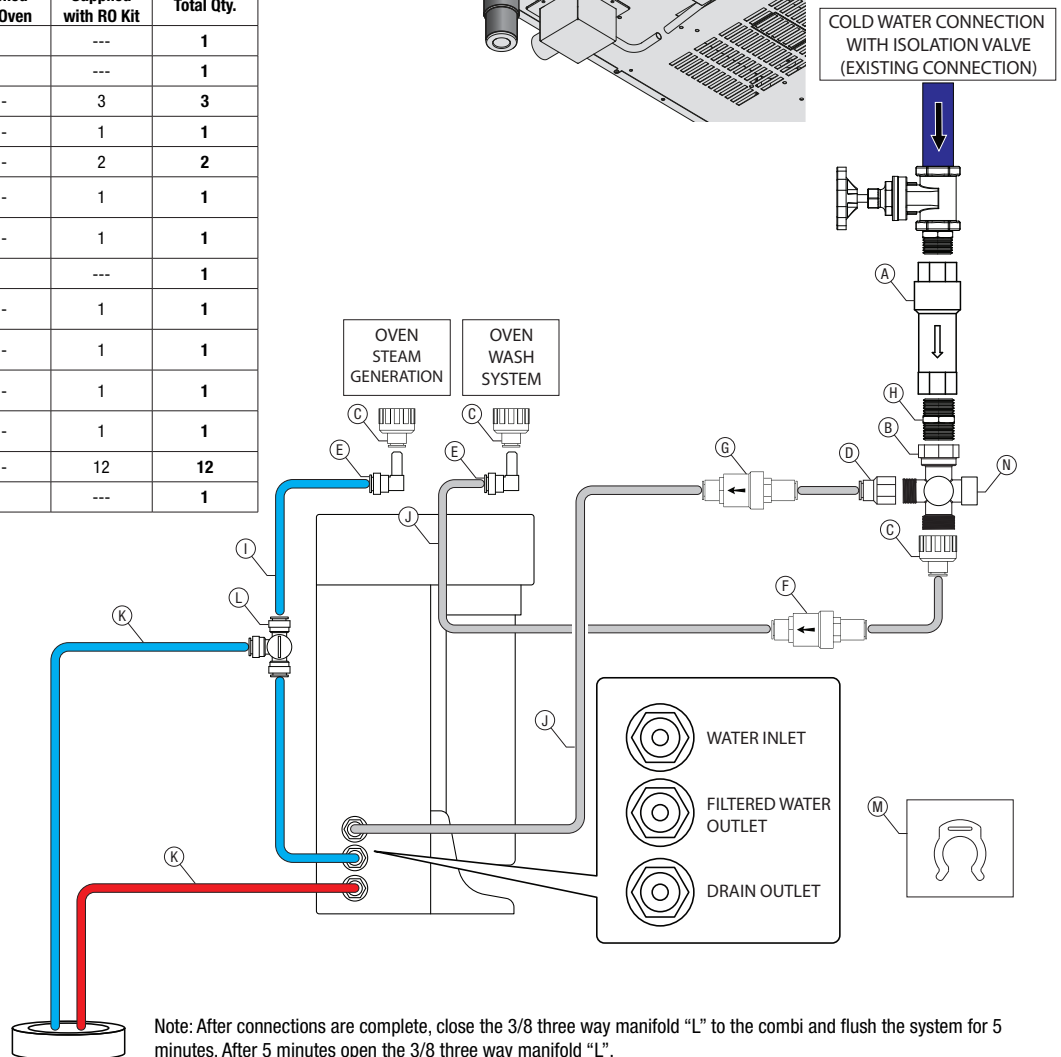

Note: After connections are complete, close the 3/8 three way manifold "L" to the combi and flush the system for 5 minutes. After 5 minutes open the 3/8 three way manifold "L".

2.6 Drainage Connection

- Drain kit is supplied with oven as illustrated. Any modification or extension to the kit must be able to resist temperatures up to 100°C
- Plumb supplied waste pipes to the Tundish
- Tundish needs to be a minimum of 300mm from the outlet on the service side of the oven
- Tundish should never be located directly below the waste outlet, or close to or under the oven control compartment. Steam from drainage should not be allowed to rise up underneath the oven control compartment
- Waste pipe must sit 25mm above the Tundish
- Secure waste pipe to the Combi oven. Securing bracket is attached to top of the Combi oven. Remove screw, reposition bracket, then secure in place with previously removed screw
- Optional: Drainage can be set up through the wall. Please remember to install a vent pointing upwards.

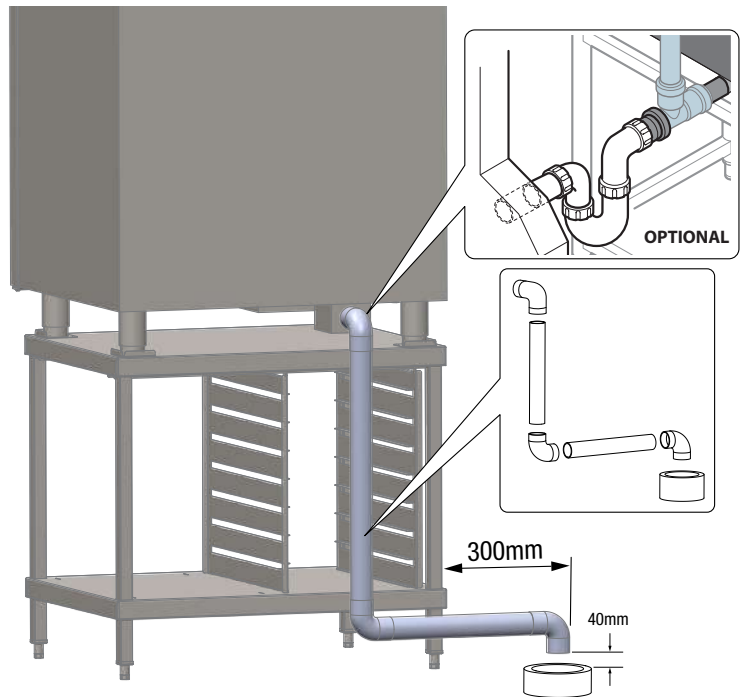

2.7 Liquid Detergent / Rinse Agent Connection

	IMPORTANT
	<p>Only Stoddart provided oven cleaners should be used. Other products may lead to voidance of warranty!</p>

Detergent line located on the underside of the oven

- If using the optional Stoddart bottle holder, place the holder on the outside of the grid rack
- Remove the bottle cap from the liquid detergent
- Drill a 8mm hole in the centre of the cap
- Feed the detergent line through the bottle cap
- Attach the weight to the detergent line
- Place the line and weight back into the bottle and secure bottle cap
- Cleaning products must not exceed 10% Sodium Hydroxide. Exceeding 10% Sodium Hydroxide will void warranty
- Wear appropriate PPE

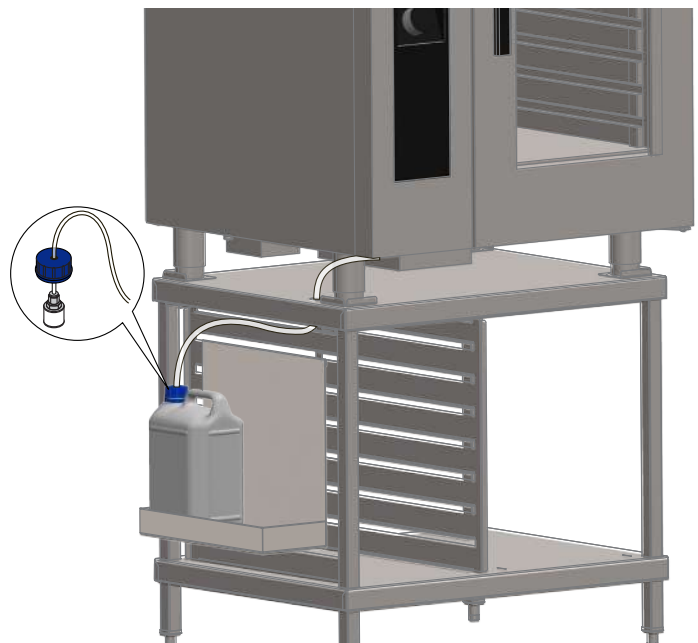

2.8 Oven Testing

The oven should be tested by completing a cooking cycle to verify that the equipment works properly, without any anomalies or problems.

Turn on the oven (See page 28)

Set a cooking cycle with temperature to 150°C, time set to 10min and humidity to 25% (See “Manual Cooking” page 32).

Press “Start/Stop”.

Carefully check the points given in the following list:

- Press the “LED Door Light” icon (See page 28), the LED door lights illuminate the oven chamber, press again to turn off
- The oven will stop if the door is opened and starts to work when the door is closed
- The thermostat that regulates the temperature in the cooking chamber is triggered when the set temperature is reached and the heating element is shut off temporarily
- The fan motor reverses the direction of rotation automatically; reversal takes place every 3minutes (time varies depending on the cooking time)
- For the ovens with two fans in the cooking chamber, the motors have the same direction of rotation
- At the end of the cooking cycle the oven emits an audible warning

2.8.1 Gas Oven Operation

Gas leakage and operation of the appliance must be tested by the installer before leaving. If the appliance fails to operate correctly after all checks have been carried out, Contact the Stoddart service department.

When the gas burner is operating the display screen will show a flame.

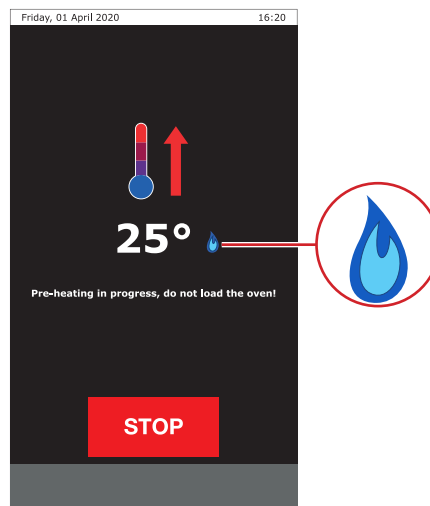

3.0 Specification



3.1 Technical Drawing

3.1.1 SERE061WT

Standard Filter	SERE061WT.SF
Reverse Osmosis	SERE061WT.RO
W x D x H (mm)	860 x 795 x 835*
<small>*Dimensions do not include water filtration system</small>	
Weight	132kg
Capacity	6 x 1/1 GN Pans
Total Connected Load	11.3kW / 25A circuit*
Electrical Connection	3Ø + N + E 415VAC / 50Hz L1 = 16.8A / L 2 = 15.2A / L3 = 15.2A

*Circuit required to be determined at installation by a qualified electrician.

Cold Water Connection	3/4 BSP 150-300 kpa Min 10°C - Max 30°C
Water Quality Requirements	Hardness 60-100ppm TDS <100mg/L Cl Chloride <20mg/L

Legend

- A** Electrical connection
- B** Steam generation water inlet (3/4" BSP)
- C** Wash system water inlet (3/4" BSP)
- D** Drain connection
- E** Humidity vent
- F** Detergent and rinse aid inlet

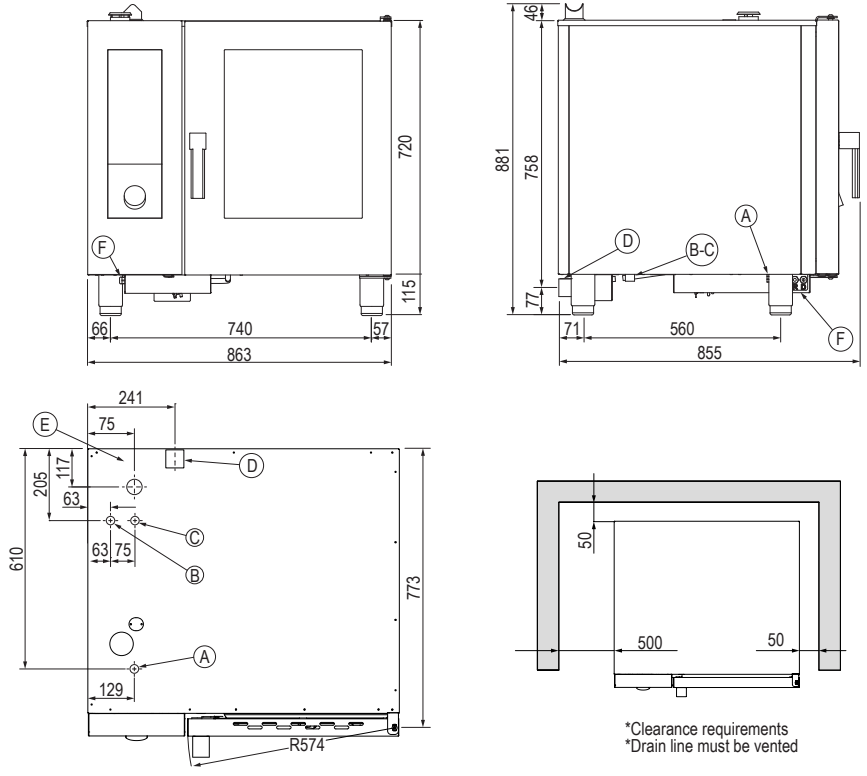

3.1.2 SERE062WT

Standard Filter	SERE062WT.SF
Reverse Osmosis	SERE062WT.RO
W x D x H (mm)	1120 x 845 x 835*
<small>*Dimensions do not include water filtration system</small>	
Weight	195kg
Capacity	6 x 2/1 GN Pans
Total Connected Load	22.2kW / 40A circuit*
Electrical Connection	3Ø + N + E 415VAC / 50Hz L1 = 32A / L 2 = 30.5A / L3 = 30.5A

*Circuit required to be determined at installation by a qualified electrician.

Cold Water Connection	3/4 BSP 150-300 kpa Min 10°C - Max 30°C
Water Quality Requirements	Hardness 60-100ppm TDS <100mg/L Cl Chloride <20mg/L

Legend

- A** Electrical connection
- B** Steam generation water inlet (3/4" BSP)
- C** Wash system water inlet (3/4" BSP)
- D** Drain connection
- E** Humidity vent
- F** Detergent and rinse aid inlet

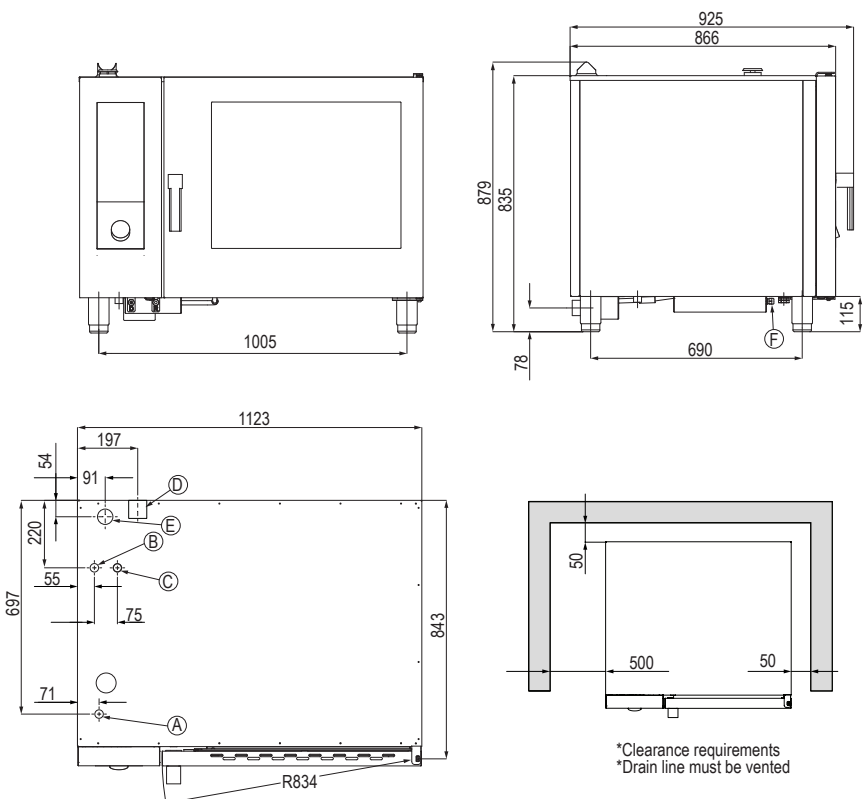

Due to continuous product research and development, the information contained herein is subject to change without notice.



3.1.3 SERE101WT

Standard Filter	SERE101WT.SF
Reverse Osmosis	SERE101WT.R0
W x D x H (mm)	860 x 795 x 1115*
*Dimensions do not include water filtration system	
Weight	168kg
Capacity	10 x 1/1 GN Pans
Total Connected Load	16.8kW / 32A circuit*
Electrical Connection	3Ø + N + E 415VAC / 50Hz L1 = 24.8A / L 2 = 22.7A / L3 = 22.7A
*Circuit required to be determined at installation by a qualified electrician.	
Cold Water Connection	3/4 BSP 150-300 kpa Min 10°C - Max 30°C
Water Quality Requirements	Hardness 60-100ppm TDS <100mg/L Cl Chloride <20mg/L

Legend

- A** Electrical connection
- B** Steam generation water inlet (3/4" BSP)
- C** Wash system water inlet (3/4" BSP)
- D** Drain connection
- E** Humidity vent
- F** Detergent and rinse aid inlet

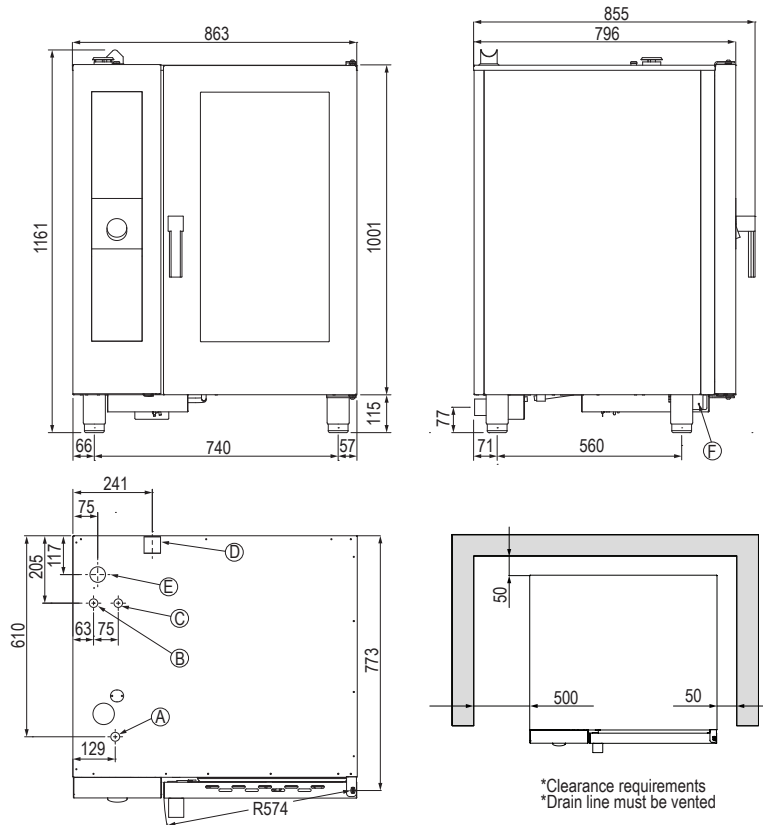

3.1.4 SERE102WT

Standard Filter	SERE102WT.SF
Reverse Osmosis	SERE102WT.R0
W x D x H (mm)	1120 x 845 x 1115*
*Dimensions do not include water filtration system	
Weight	220kg
Capacity	10 x 2/1 GN Pans
Total Connected Load	25.8kW / 63A circuit*
Electrical Connection	3Ø + N + E 415VAC / 50Hz L1 = 38.2A / L 2 = 34.8A / L3 = 34.8A
*Circuit required to be determined at installation by a qualified electrician.	
Cold Water Connection	3/4 BSP 150-300 kpa Min 10°C - Max 30°C
Water Quality Requirements	Hardness 60-100ppm TDS <100mg/L Cl Chloride <20mg/L

Legend

- A** Electrical connection
- B** Steam generation water inlet (3/4" BSP)
- C** Wash system water inlet (3/4" BSP)
- D** Drain connection
- E** Humidity vent
- F** Detergent and rinse aid inlet

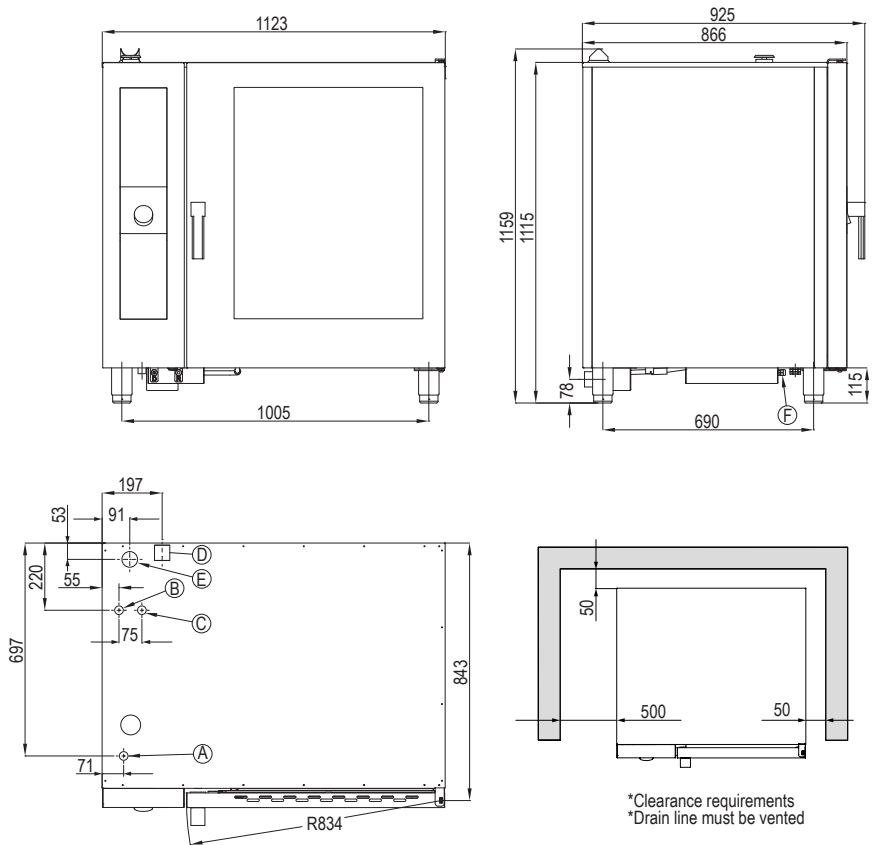

3.0 Specification

3.1.5 SERE201WT

Standard Filter	SERE201WT.SF
Reverse Osmosis	SERE201WT.RO
W x D x H (mm)	995 x 835 x 1850*
*Dimensions do not include water filtration system	
Weight	290kg
Capacity	20 x 1/1 GN Pans

Total Connected Load	33.4kW / 63A circuit*
Electrical Connection	3Ø + N + E 415VAC / 50Hz L1 = 48.8A / L2 = 45.4A / L3 = 45.4A

*Circuit required to be determined at installation by a qualified electrician.

Cold Water Connection	3/4 BSP 150-300 kpa Min 10°C - Max 30°C
------------------------------	---

Water Quality Requirements	Hardness	60-100ppm
	TDS	<100mg/L
	Cl Chloride	<20mg/L

Legend

- A** Electrical connection
- B** Steam generation water inlet (3/4" BSP)
- C** Wash system water inlet (3/4" BSP)
- D** Drain connection
- E** Humidity vent
- F** Detergent and rinse aid inlet

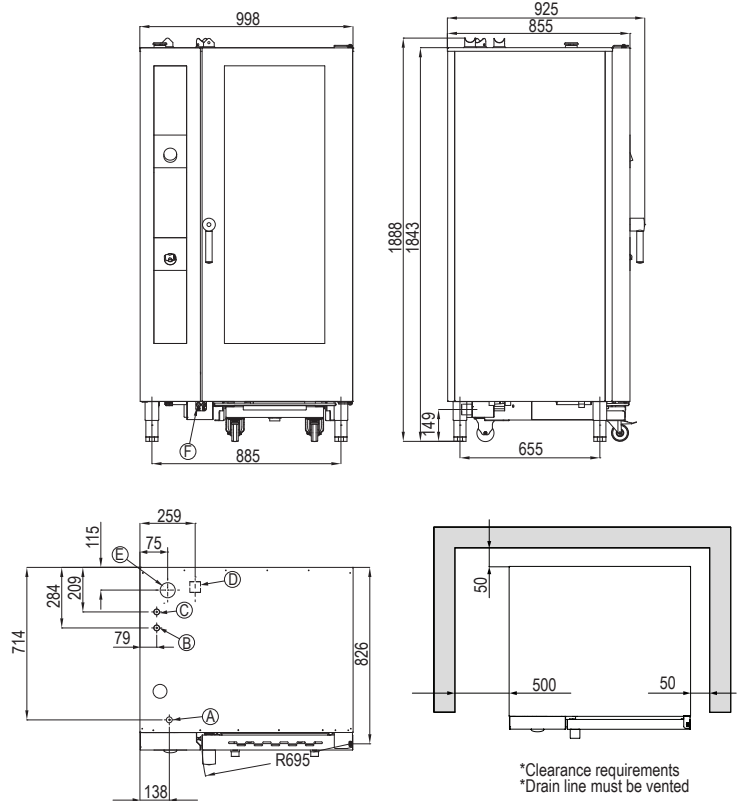

3.1.6 SERE202WT

Standard Filter	SERE202WT.SF
Reverse Osmosis	SERE202WT.RO
W x D x H (mm)	1200 x 910 x 1850*
*Dimensions do not include water filtration system	
Weight	370kg
Capacity	20 x 2/1 GN Pans

Total Connected Load	51.6kW / 100A circuit*
Electrical Connection	3Ø + N + E 415VAC / 50Hz L1 = 76.3A / L2 = 69.6A / L3 = 69.6A

*Circuit required to be determined at installation by a qualified electrician.

Cold Water Connection	3/4 BSP 150-300 kpa Min 10°C - Max 30°C
------------------------------	---

Water Quality Requirements	Hardness	60-100ppm
	TDS	<100mg/L
	Cl Chloride	<20mg/L

Legend

- A** Electrical connection
- B** Steam generation water inlet (3/4" BSP)
- C** Wash system water inlet (3/4" BSP)
- D** Drain connection
- E** Humidity vent
- F** Detergent and rinse aid inlet

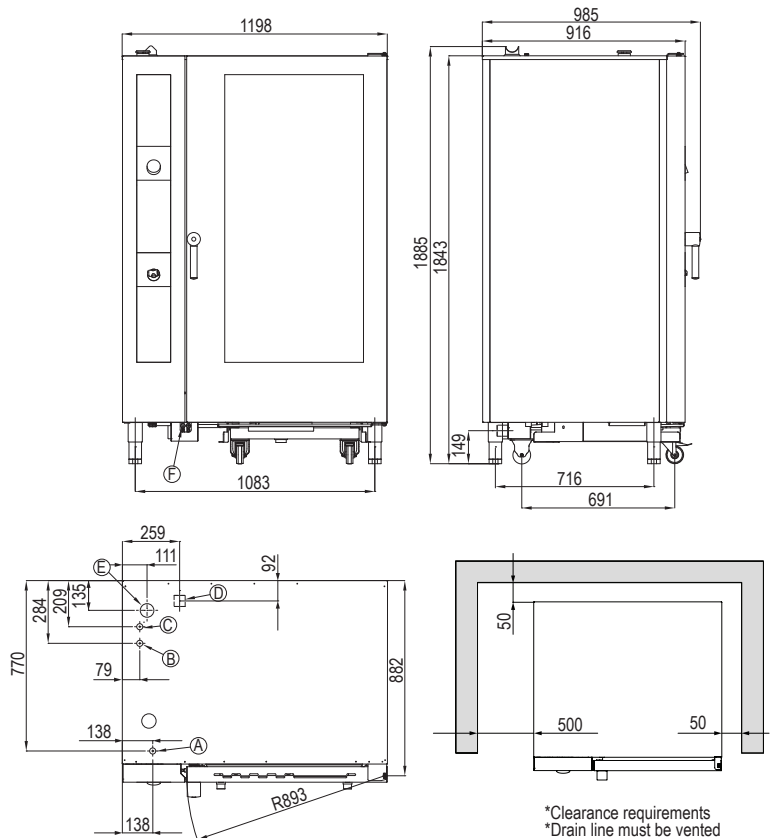

Due to continuous product research and development, the information contained herein is subject to change without notice.

3.1.7 SERG061WT

Specifications

Model	SERG061WT
W x D x H (mm)	863 x 855 x 881
Weight	142kg
Capacity	6 X 1/1GN
Gas	3/4 BSP
(Natural / Universal LPG)	43.2MJ/Hr
Power	1Ø + N + E 230VAC / 50Hz / 0.4kW 10A Plug and Lead
Waste Connection	50mm
Cold Water Connection	3/4 BSP 150-350 kpa Min 10°C Max 30°C

Legend

- A** Electrical connection
- B** Gas inlet (3/4" BSP)
- C** Steam generation water inlet (3/4" BSP)
- D** Wash system water inlet (3/4" BSP)
- E** Drain connection
- F** Humidity vent
- G** Gas emission exhaust
- H** Detergent and rinse aid inlet

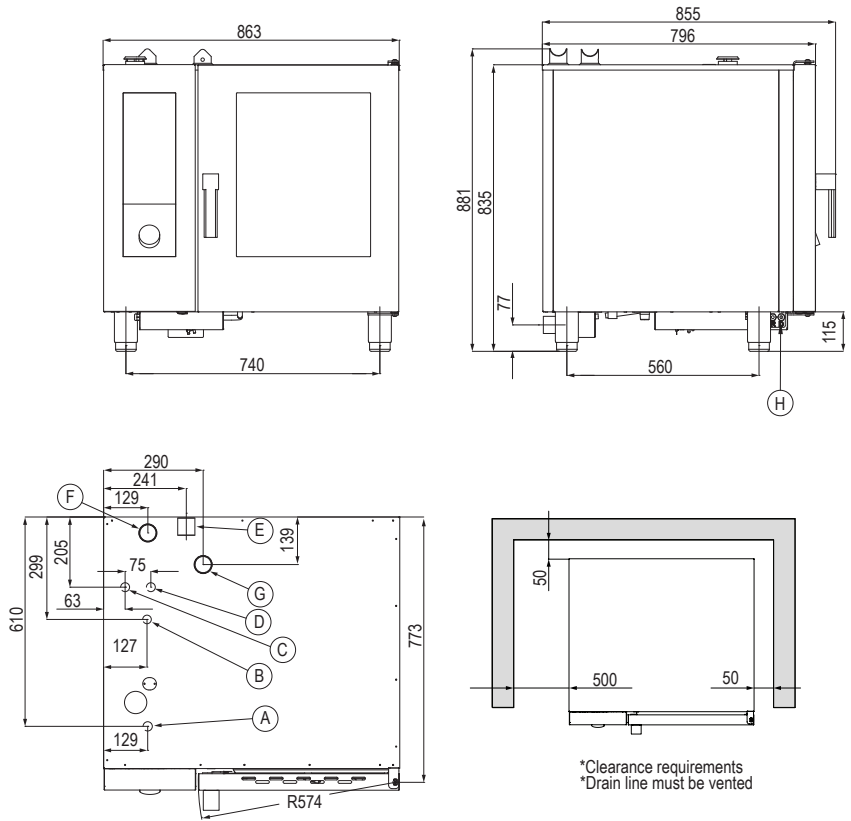

*Clearance requirements
*Drain line must be vented

3.1.8 SERG101WT

Specifications

Model	SERG101WT
W x D x H (mm)	863 x 855 x 1161
Weight	178kg
Capacity	10 X 1/1GN
Gas	3/4 BSP
(Natural / Universal LPG)	68.4MJ/Hr
Power	1Ø + N + E 230VAC / 50Hz / 0.5kW 10A Plug and Lead
Waste Connection	50mm
Cold Water Connection	3/4 BSP 150-350 kpa Min 10°C Max 30°C

Legend

- A** Electrical connection
- B** Gas inlet (3/4" BSP)
- C** Steam generation water inlet (3/4" BSP)
- D** Wash system water inlet (3/4" BSP)
- E** Drain connection
- F** Humidity vent
- G** Gas emission exhaust
- H** Detergent and rinse aid inlet

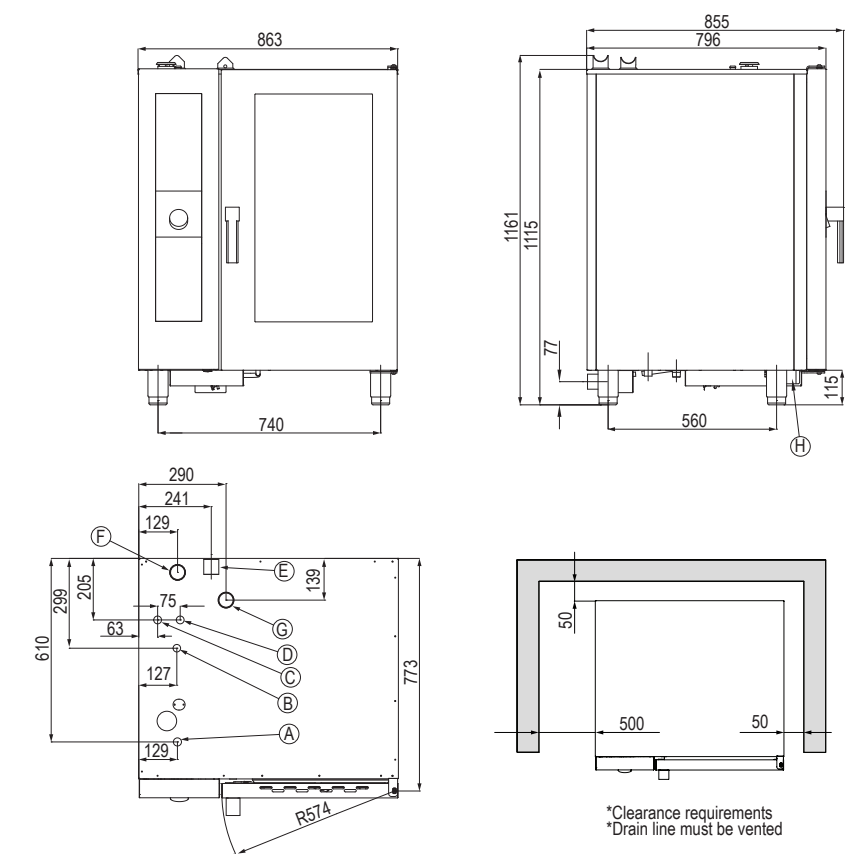

*Clearance requirements
*Drain line must be vented

3.0 Specification

3.1.9 SERG102WT

Specifications

Model	SERG102WT
W x D x H (mm)	1123 x 925 x 1159
Weight	250kg
Capacity	10 X 2/1GN
Gas	3/4 BSP
(Natural / Universal LPG)	97.2MJ/Hr
Power	1Ø + N + E 230VAC / 50Hz / 0.6kW 10A Plug and Lead
Waste Connection	50mm
Cold Water Connection	3/4 BSP 150-350 kpa Min 10°C Max 30°C

Legend

- A** Electrical connection
- B** Gas inlet (3/4" BSP)
- C** Steam generation water inlet (3/4" BSP)
- D** Wash system water inlet (3/4" BSP)
- E** Drain connection
- F** Humidity vent
- G** Gas emission exhaust
- H** Detergent and rinse aid inlet

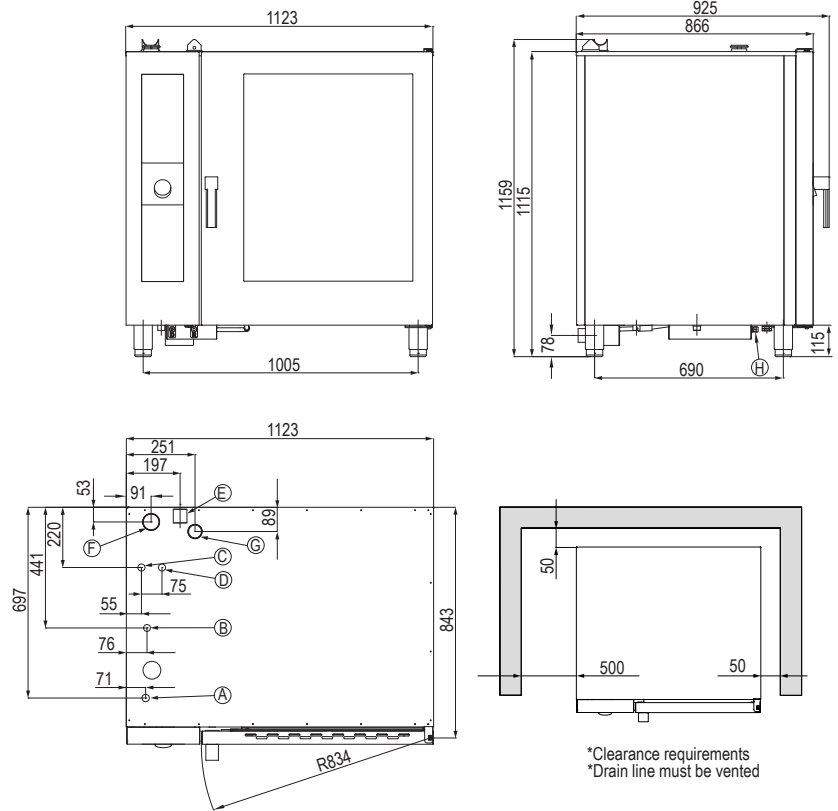

3.1.10 SERG201WT

Specifications

Model	SERG201WT
W x D x H (mm)	998 x 925 x 1888
Weight	300kg
Capacity	20 X 1/1GN
Gas	3/4 BSP
(Natural / Universal LPG)	129.6MJ/Hr
Power	1Ø + N + E 230VAC / 50Hz / 0.8kW 10A Plug and Lead
Waste Connection	50mm
Cold Water Connection	3/4 BSP 150-350 kpa Min 10°C Max 30°C

Legend

- A** Electrical connection
- B** Gas inlet (3/4" BSP)
- C** Steam generation water inlet (3/4" BSP)
- D** Wash system water inlet (3/4" BSP)
- E** Drain connection
- F** Humidity vent
- G** Gas emission exhaust
- H** Detergent and rinse aid inlet

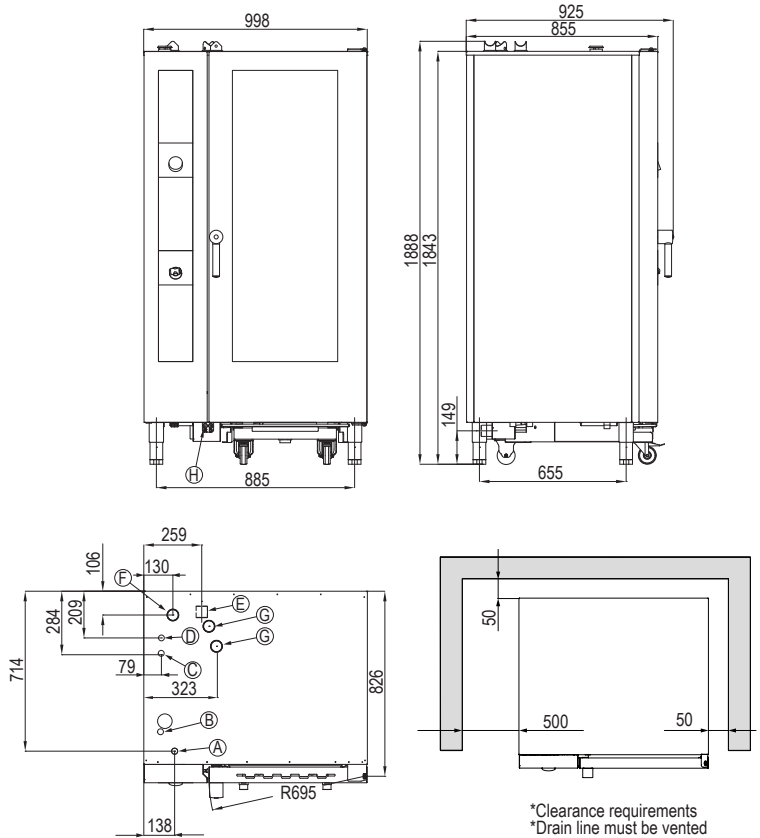

3.1.11 SERG202WT

Specifications

Model	SERG202WT
W x D x H (mm)	1198 x 985 x 1885
Weight	400kg
Capacity	20 X 2/1GN
Gas	3/4 BSP
(Natural / Universal LPG)	194.4MJ/Hr
Power	1Ø + N + E 230VAC / 50Hz / 1.3kW 10A Plug and Lead
Waste Connection	50mm
Cold Water Connection	3/4 BSP 150-350 kpa Min 10°C Max 30°C

Legend

- A** Electrical connection
- B** Gas inlet (3/4" BSP)
- C** Steam generation water inlet (3/4" BSP)
- D** Wash system water inlet (3/4" BSP)
- E** Drain connection
- F** Humidity vent
- G** Gas emission exhaust
- H** Detergent and rinse aid inlet

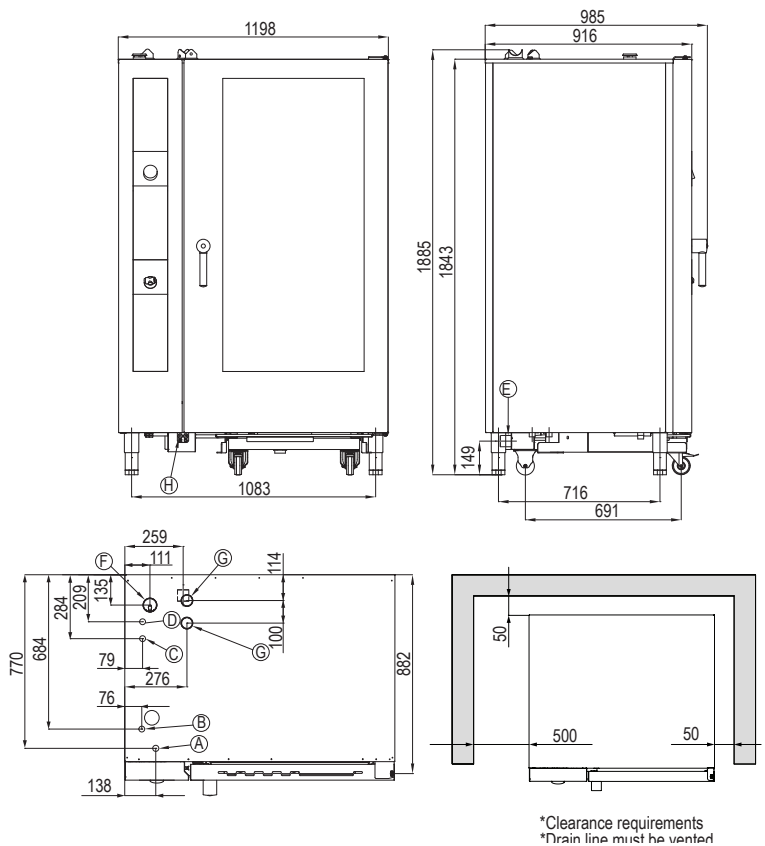

4.1 General Overview

4.1.1 Control Interface

- A. Start-up and Shut-down:
 - Press the right side of the switch to turn the oven on
 - Press the left side of the switch to turn the oven off
- B. Touch Screen: The operating parameters of the appliance are set and displayed on this screen
- C. Manual Cooking: Recipe settings are entered manually
- D. One Touch: 9 favourite recipes can be saved
- E. Recipe Book: Default and saved recipes
- F. Settings: Access service menu, select wash cycle, chamber cooling
- G. Chamber Light: Turns the oven chamber light on/off
- H. Navigation Dial: The dial is used to set the values on the screen. If the dial is pressed, the value entered is confirmed

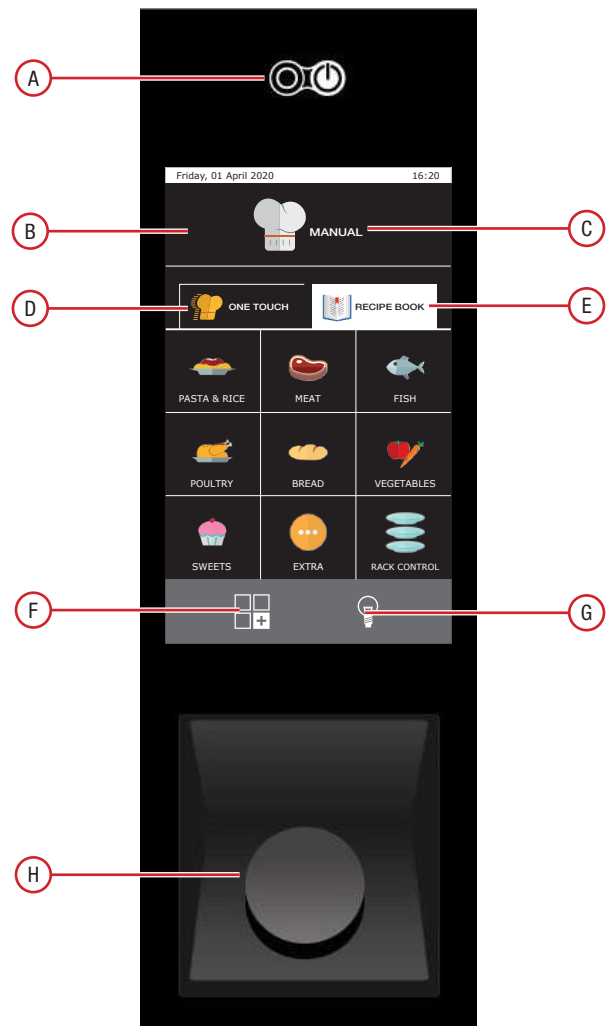

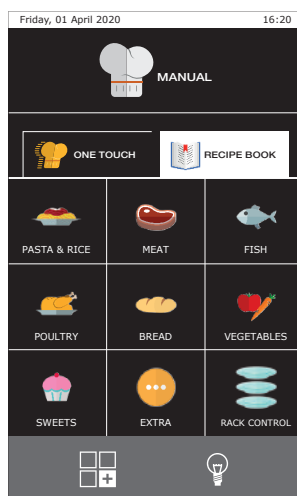

4.1.2 Cooking Screen Icons:



-  **Home:**
 - Return to home screen

-  **Settings menu:**
 - Save or modify a recipe
 - Select and start a wash cycle
 - Cool off the chamber;
 - Access settings (e.g. language, time, etc.)

-  **Delayed start:**
 - Set a delayed start





-  **Chamber Light:**
 - Switch the light in the chamber on/off

-  **Return:**
 - Return to the previous screen

Due to continuous product research and development, the information contained herein is subject to change without notice.

4.1.3 Cooking Methods

To cook varying types of food to perfection, a sequence of different cooking methods should be used.

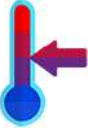
Cooking Method	Temperature Range	Humidity Input	Humidity Extraction	Uses
 <p>Convection Cooking: Convection cooking uses the dry heat of the heating elements that the fans spread at a variable speed to ensure quick and even cooking.</p>	50°C to 300°C	Manual input: By pressing and holding the humidity icon during the cooking cycle 	Manual	Dry confectionery cooking Frozen food cooking External browning of foods Food grilling
 <p>Combi Cooking: Food is cooked with a humidity percentage set by the user. Ventilation inside the cooking chamber ensures quick and even cooking.</p>	50°C to 270°C	Input: 0% to 100%	Automatic	Cooking of the dishes that must remain soft inside (e.g. Poultry) Leavening
 <p>Steam Cooking: Food is cooked using steam, which is evenly spread by the fans at a variable speed.</p>	50°C to 120°C	100% fixed humidity (Cannot be adjusted)	Flue vent always closed	Vacuum cooking (sous-vide) Cooking of delicate dishes Cooking of creams and sauces Pasteurisation Regeneration Leavening
 <p>Smoking It allows the user to set a type of cooking suitable for using a smoking device (optional, contact the Stoddart sales department).</p>	10°C to 200°C	No Input (Humidity cannot be added)	Manual	Meat cooking
 <p>Keep Warm: Keeps the temperature of the cooked food constant for a set or indefinite time</p>	50°C to 120°C	Input: 0% to 100%	Automatic	Keeping cooked food warm

4.2 Setup - Configuration Menu

4.2.1 Date and Time / Language

Before commencing cooking, the initial setup needs to be entered, such as Time/Date and Language.

- A. Press "Settings"
- B. Press "Service"
- C. Press "Configuration"
- D. Select "Date and Time" from the configuration menu
- E. Select and adjust each of the parameters accordingly
- F. Press "SAVE" to confirm the settings

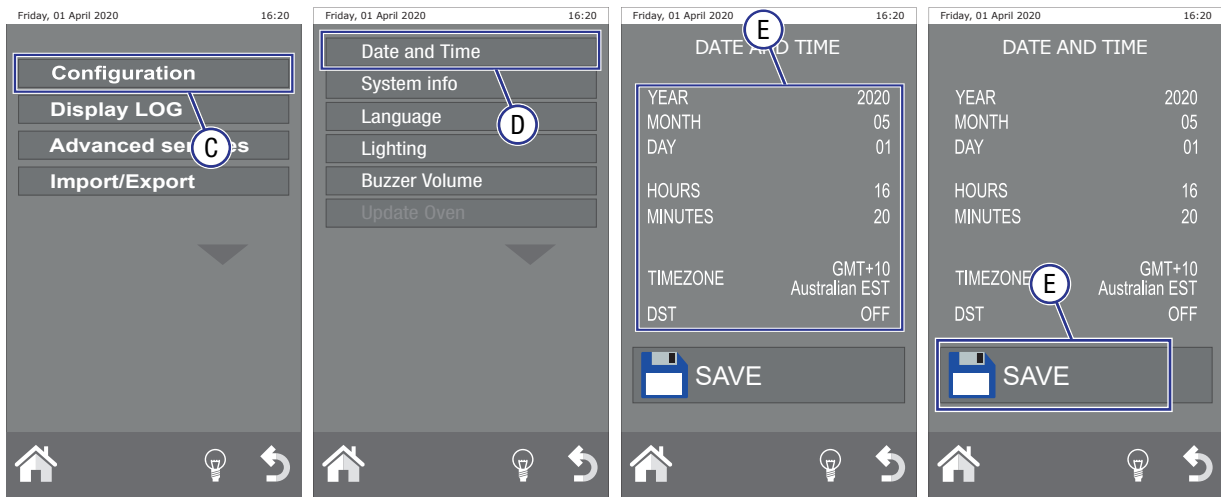
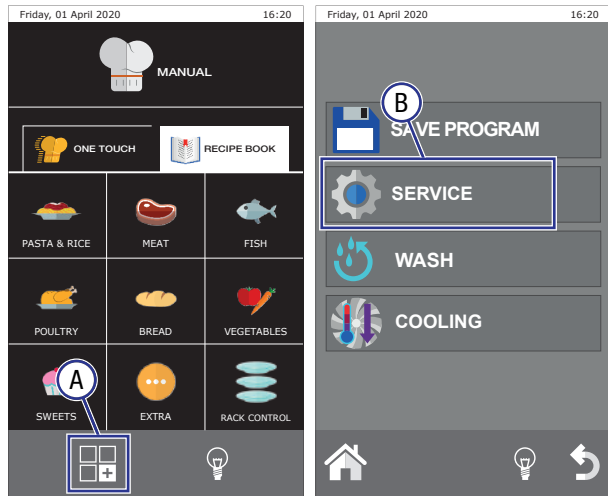

4.2.2 System Info

This function allows the display of the software version installed in the oven and the serial number of the oven.

- A. Press "Settings"
- B. Press "Service"
- C. Press "Configuration"
- D. Select "Date and Time" from the configuration menu
- E. Select and adjust each of the parameters accordingly
- F. Press "SAVE" to confirm the settings

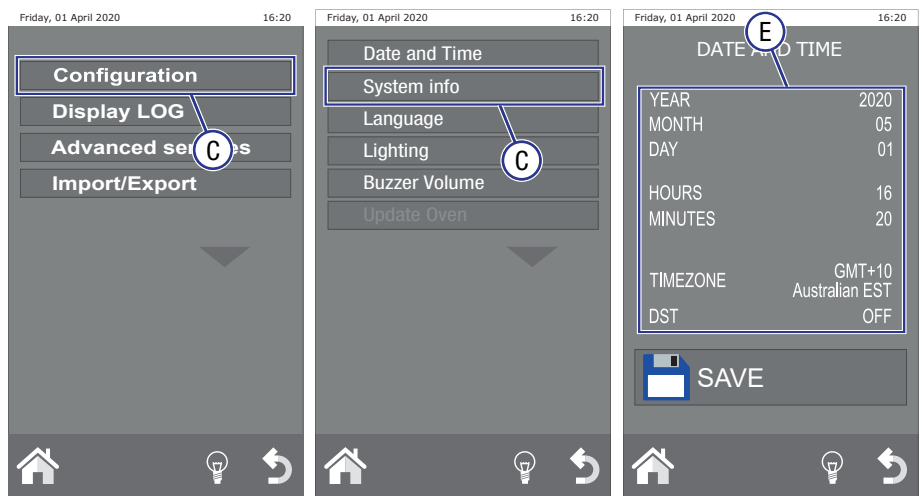

Due to continuous product research and development, the information contained herein is subject to change without notice.

4.2.3 Language

This function allows the user to select the preferred language for the oven.

To access the language selection:

- Enter the "Configuration" menu
- Press "Language"
- Select the preferred language i.e. English

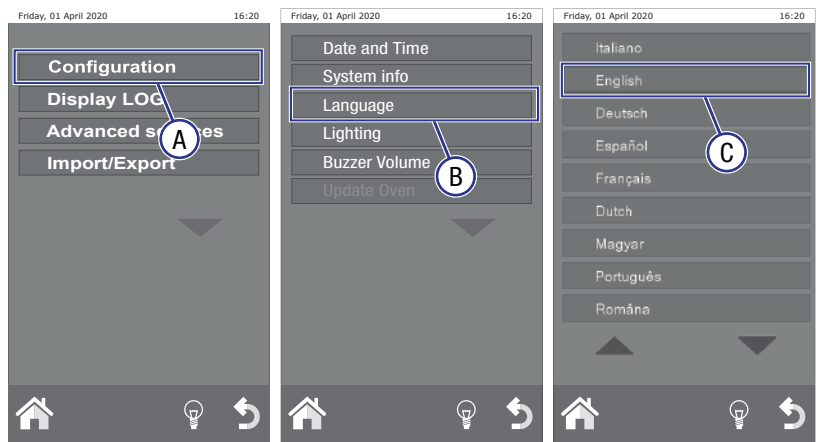

4.2.4 Display Brightness

Display brightness can be adjusted to suit the users preference.

To access Display Brightness:

- Enter the "Configuration" menu
- Select "Lighting"
- Slide the white bar to adjust the brightness
- Press "Save" to confirm

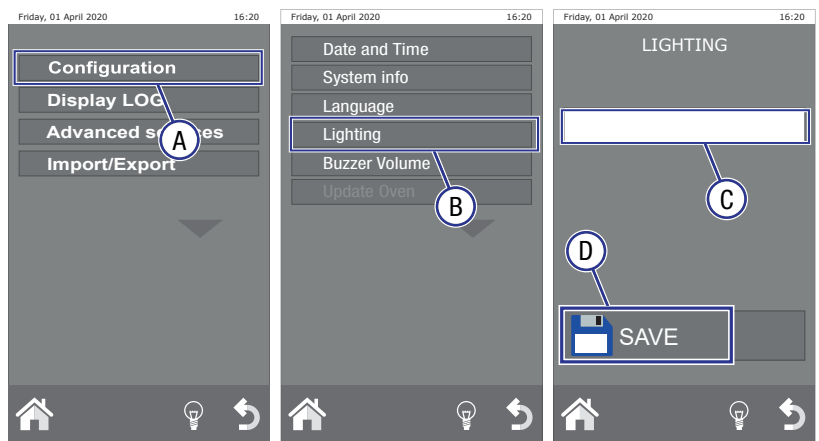

4.2.5 Buzzer Volume

Buzzer Volume can be adjusted to suit the users preference.

To access Buzzer Volume:

- Enter the "Configuration" menu
- Select "Buzzer Volume"
- Slide the white bar to adjust the Buzzer Volume
- Press "Save" to confirm

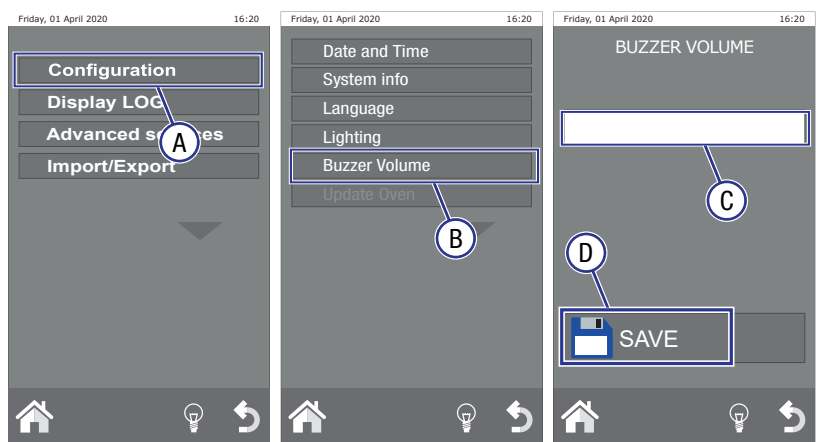

4.3 Manual Cooking

4.3.1 Initial Settings

It is possible and easy to create customised cooking programs that can have up to 9 different phases plus pre-heating. Every cooking phase is represented by a cooking mode (convection, mixed, steam, etc.) with specific time, humidity, ventilation parameters, etc. For example: for a roast dish, a program can be created that contains a browning phase, a cooking phase and a hold phase.

Set the cooking parameters for one or more cooking phases. Once these settings are saved, a recipe can be started without saving (the entered parameters are not saved) or start a recipe after saving it (for future use).

Manual cooking cycles require the following actions:

- Setting a manual pre-heating function (optional)
- PHASE 1 parameter settings
- Selecting the cooking method: convection / steam / combi
- Setting the temperature in the chamber
- Setting the duration of the cooking cycle (by setting the time or using a core probe)
- Setting fan speed
- Humidity input/extraction (depending on the cooking cycle chosen)
- Setting additional cooking phases (optional)
- Saving the recipe (optional)
- Starting a recipe

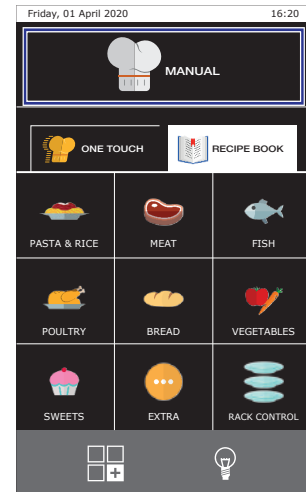

4.3.2 Selecting The Cooking Method

Select the cooking method required, by touching the relative icon (convection cooking mode in the example).

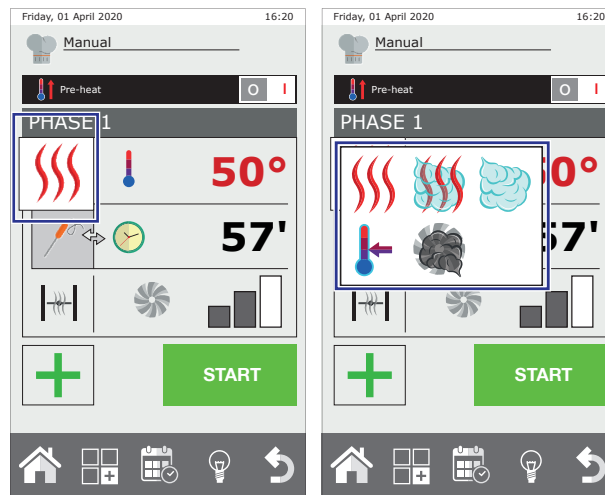

4.3.3 Selecting The Temperature

Choosing the correct cooking temperature is essential to achieve optimal results. To set the temperature:

- Touch the "temperature" field
- Turn the navigation dial to select the desired temperature
- Press the navigation dial to save the set value

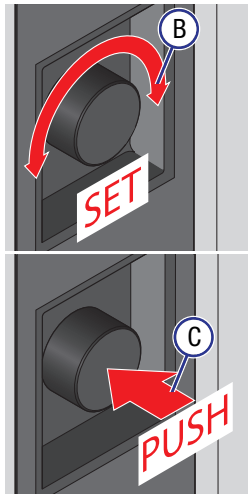
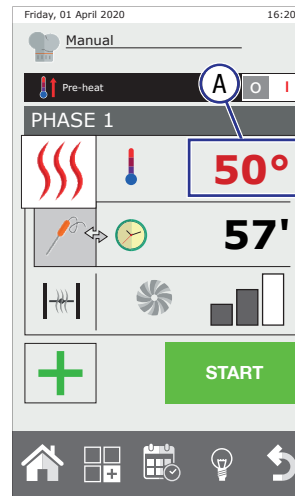

4.3.4 Setting Preheating

The preheating function is recommended for achieving optimal cooking results. This function can be toggled on or off by moving the 0/I cursor to the top right. Cursor on:

- "0": phase 1 starts immediately skipping the preheating stage.
- "I": preheating is enabled. The oven manages the temperature automatically based on the temperature you have set for phase

As soon as this temperature is reached, the oven emits an audible beeping and a window opens to indicate that the oven is ready to load. When the door is closed, phase 1 automatically starts according to the set parameters.

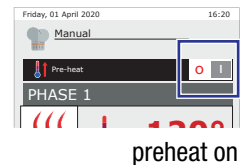
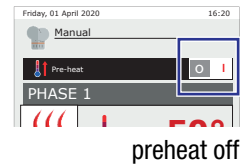
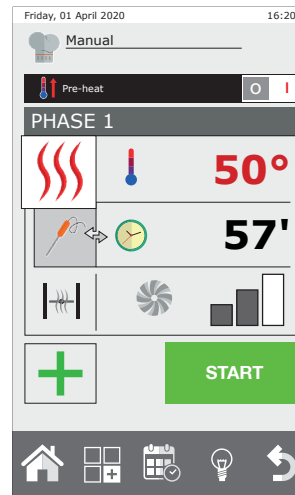

4.3.5 Time Setting:



- Time setting:
The cooking cycle stops automatically when the set time expires (range: from 1 minute to 40 hours)

To set the time duration:

- Select "Time"
- Touch the value field to set the cooking time
- Turn the navigation dial to adjust the temperature value
- Press the navigation dial to save the set value

Note: For the oven to run continuously, touch the time field and turn the navigation dial to the left until the display shows INF (time = Infinity).

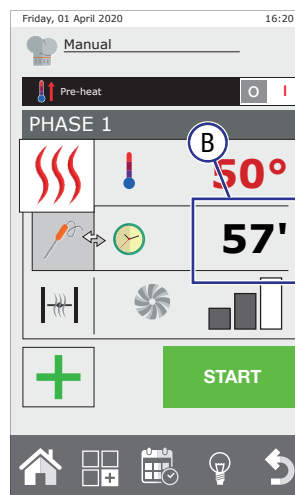
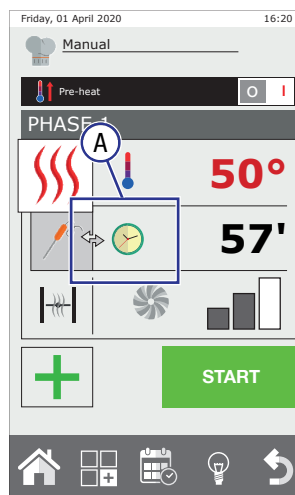

4.3.6 Core Probe:



- Core probe: the cooking cycle stops automatically when the temperature measured by the probe inside the food reaches the set value

To set the Core Probe temperature:

- Connect the core probe to the oven
- Select Core probe
- Touch the value field to set the core probe temperature
- Turn the navigation dial to adjust the temperature value
- Press the navigation dial to save the set value

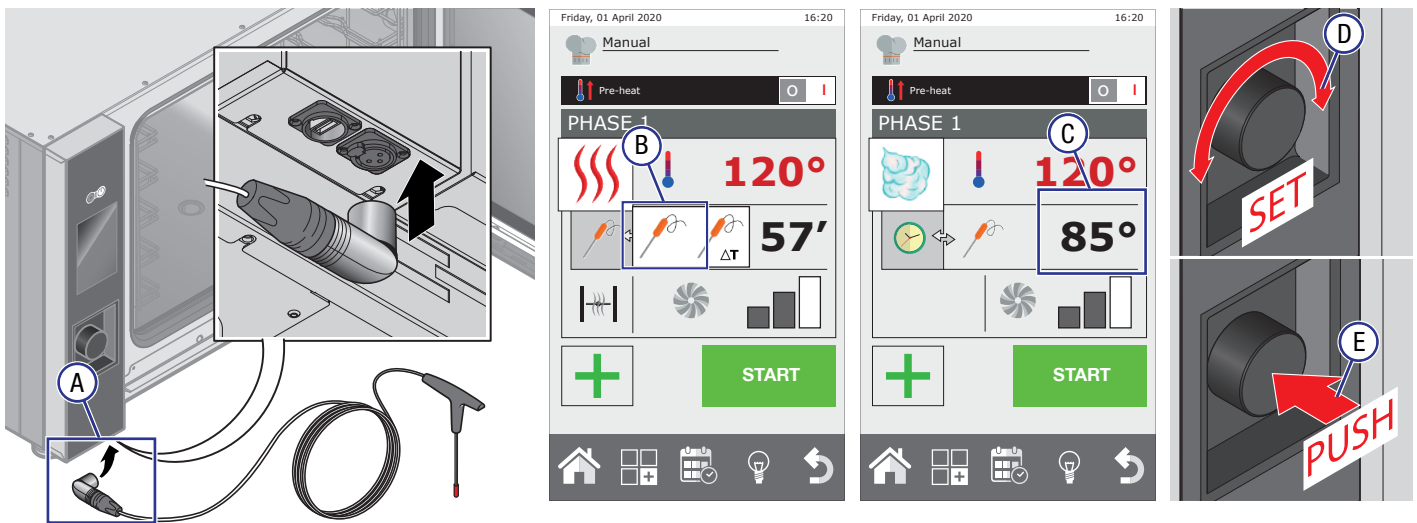

Note: When not in use, place the probe back into the magnetic support.

At the end of the cooking cycle, take care to remove the probe from the core before taking the tray out of the oven. The core probe is very sharp and it reaches high temperatures after cooking, do not pull the probe by the connection wire to remove it.

Do not insert the hot probe in frozen food to prevent thermal shock to the probe, which can cause the probe to become damaged.

Dishes	Recommended Core Temperature
Beef tenderloin	53-58°C
Beef (ribs, entrecote, steaks)	from 50 °C to 55 °C: rare from 55 °C to 65 °C: medium from 66 °C to 70 °C: well done
Pork fillet	58-64°C
Roast veal	72-75°C

Dishes	Recommended Core Temperature
Porchetta (pork roast)	68-75°C
Lamb sirloin	58-65°C
Chicken - turkey (whole)	85-87°C
Salmon (fillets)	58-65°C
Shin of pork/ribs	80-85°C

4.3.7 Delta T(Δt):



- Delta T(Δt):
During the cooking cycle, the oven increases or decreases the cooking chamber's temperature automatically to keep the Delta T (Δt) value constant (e.g. 30°C). These cooking cycles are perfect for cooking meat slowly and at low temperatures to keep it soft and tender without losing excessive weight.
Delta T (Δt) = Temperature in the chamber - (minus) Probe core temperature

The Delta T(Δt) function is used mainly for slow, low temperature cooking.

In Delta T(Δt) mode, the product core temperature is set and the chamber temperature is set between 15°C - 30°C higher. As the core temperature rises, the temperature in the chamber will increase maintaining the set difference.

Note: A probe must be used for the Delta T(Δt) function.

To set the Delta T:

- Connect the core probe to the combi oven
- Select Core probe then press the Delta T icon
- Touch the value fields to set the core probe temperature and chamber temperature (set the chamber temperature between 15°C - 30°C higher than the core probe)
- Turn the navigation dial to adjust the temperature value
- Press the navigation dial to save the set value

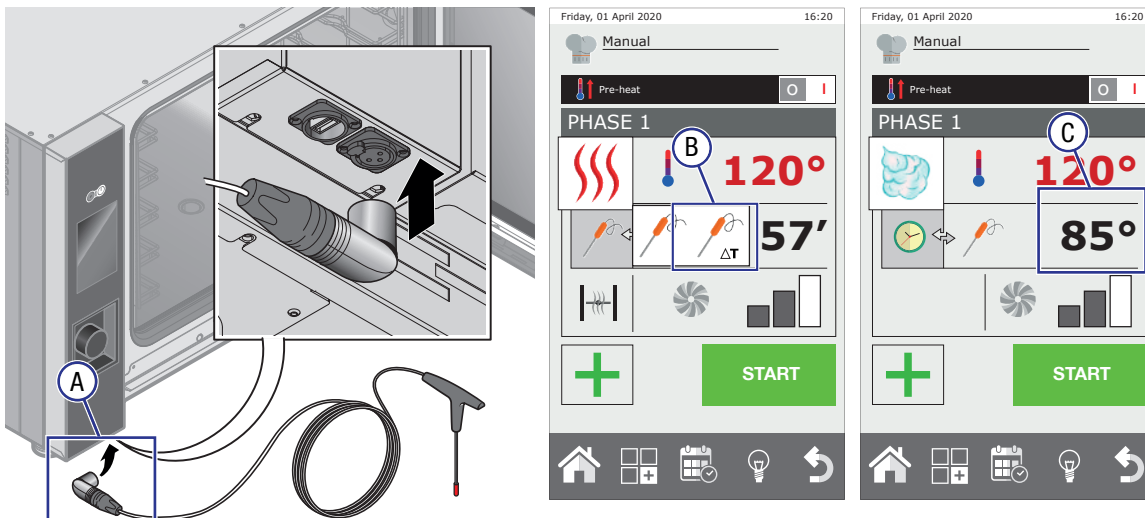

Note: When not in use, place the probe back into the magnetic support.

At the end of the cooking cycle, take care to remove the probe from the core before taking the tray out of the oven. The core probe is very sharp and it reaches high temperatures after cooking, do not pull the probe by the connection wire to remove it.

Do not insert the hot probe in frozen food to prevent thermal shock to the probe, which can cause the probe to become damaged.

4.3.8 Fan Rotation Speed

The fan rotation speed parameter can be adjusted when using “Convection” and “Combi” modes.

To set the fan speed:

- Touch the fan field;
- Turn the navigation dial to adjust the temperature value
- Press the navigation dial to save the set value

Note: For best cooking results, the fans reverse the rotation direction periodically. The oven manages this phase based on the cooking time set without the need for setting anything else.

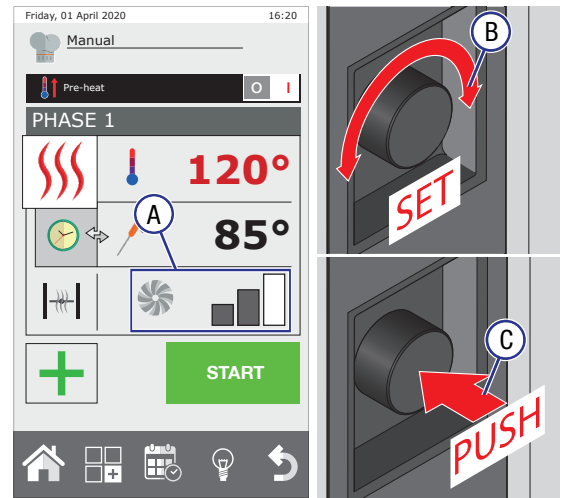





4.3.9 Manual Adjustment of Vent

Only when using convection cooking, is it possible to choose for the flue to be opened or closed. The vent has the task of maintaining or expelling moisture from the oven. When the vent is open, the higher the fan speed, the greater the evacuation of moisture from the oven chamber.

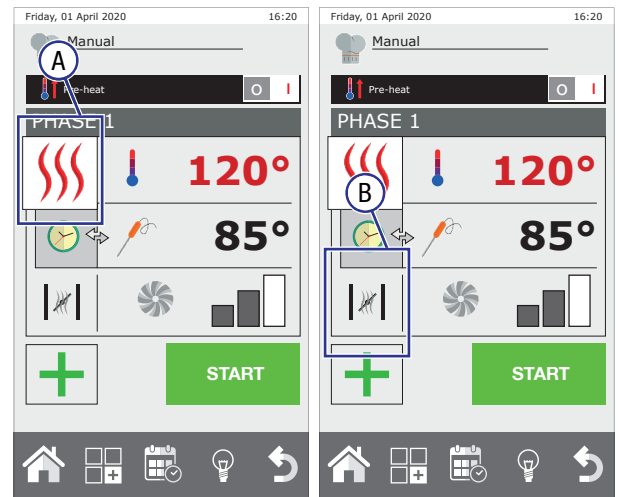
To open or close vent:

- Touch the extraction field
- Turn the navigation dial to adjust the temperature value
- Press the navigation dial to save the set value





Type of cooking	Humidity input	Humidity extraction
Convection 	manual input, press: 	closed flue  open flue 

4.3.10 Humidity Percentage in Combi Mode

Only in “Combi” mode can the percentage of humidity for the oven to maintain during cooking can be set. With the patented Meteo System (humidity control), the relative humidity in the cooking chamber is measured, humidity is added or removed, to maintain the settings programmed by the operator.

To set moisture percentage:

- Touch the Humidity field
- Turn the navigation dial to adjust the percentage value
- Press the navigation dial to save the set value

Type of cooking	Humidity input	Humidity extraction
Combi 	 0% adjustable from 0% to 100%	the oven opens and closes the flue vent automatically

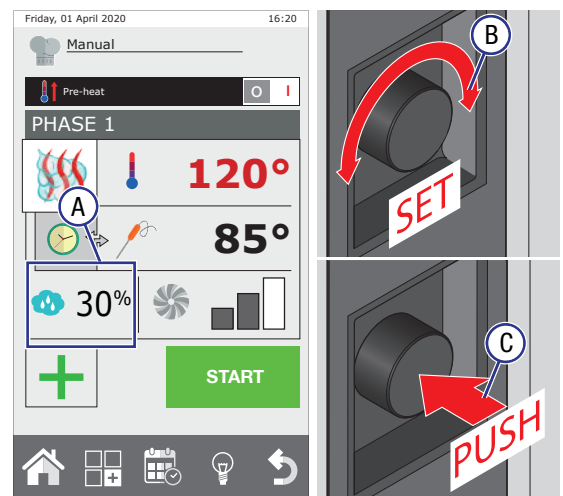

4.3.11 Steam Phase

The steam function can be set by selecting “Steam”, with an adjustable temperature range of 50°C-120°C

The level of steam cannot be adjusted (set to 100%).

Type of cooking	Humidity (default)	Humidity extraction
 Steam	100%	flue vent always closed

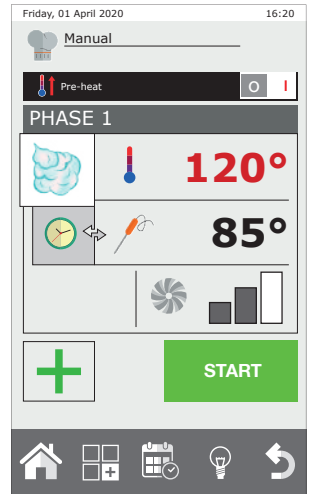

4.3.12 Holding Phase

The holding phase is usually the last phase to be set, with the purpose of maintaining the products at or above 65°C (food safe temperature) without cooking the product.

The holding phase, by default has the humidity set at 20% and the fan speed set at 1.

For effective holding, it is recommended not to adjust the fan speed. When holding roasted products, a humidity setting of 20% - 35% is recommended, in the case of brazing or stewing, a humidity setting of 90% - 100% is recommended.

To set a holding phase:

- Select the cooking method “Holding”
- Set the parameters (temp, time, fan speed etc.)
- Load product into the oven, press “Start” (press “+ NEW PHASE” if extra phases is required)

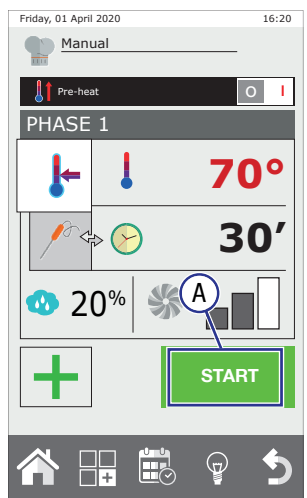
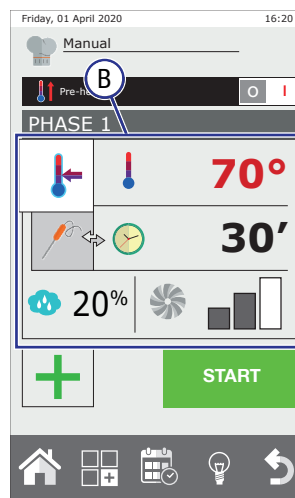
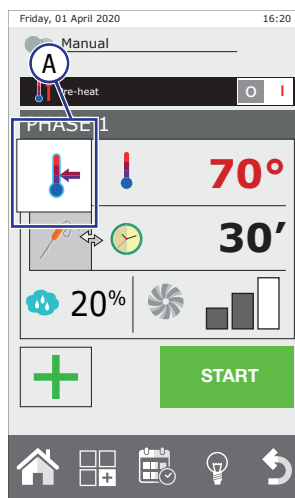

4.3.13 Setting Multiple Cooking Phases (optional)

After setting all phase 1 parameters additional cooking phases can be set if required.

Up to 9 cooking phases can be programmed, (each cooking phase can be used for different cooking methods and parameters).

To set additional phases:

- Touch the field “+ NEW PHASE”
- Set the new phase cooking type. Enter all required parameters (as shown in previous pages)
- Each phase can be adjusted if required. Touch the “See Phase List” field to adjust any of the set phases

Note: If phase one of the phases is set to INF (the oven runs continuously), extra phases cannot be added after that phase.

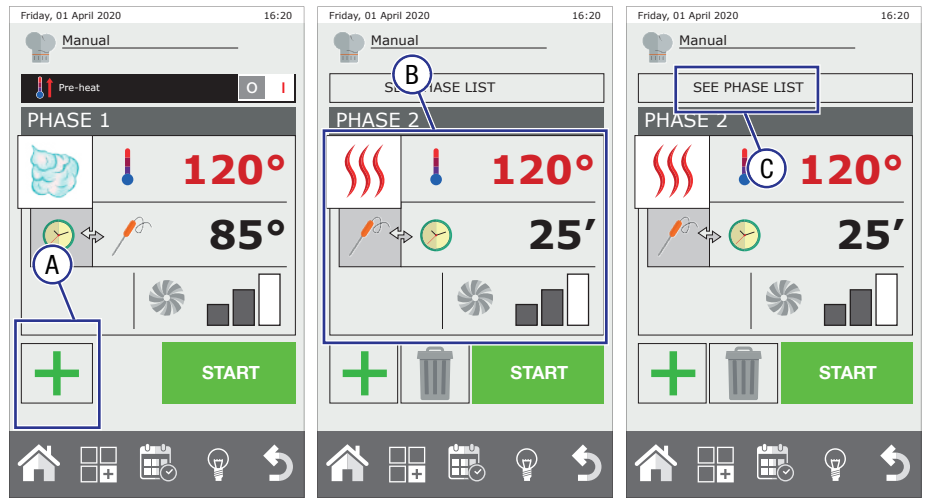

4.3.14 Cooling Phase

The temperature inside the oven chamber can be cooled between phases.

The cooling phase can only be set from phase 2 onwards.

In order to make cooling as fast as possible, do not modify the ventilation and humidity discharge valve values unless indispensable.

To set a holding phase:

- Touch the field “+ NEW PHASE”
- Select the cooking method “Cooling”
- By default the temperature is set to 100°C (the adjustable temperature range is 100°C to 300°C)
- Load product into the oven, press “Start” (press “+ NEW PHASE” if extra phases is required)

Note: For the cooling phase to perform efficiently, do not close the ventilation valve unless necessary.

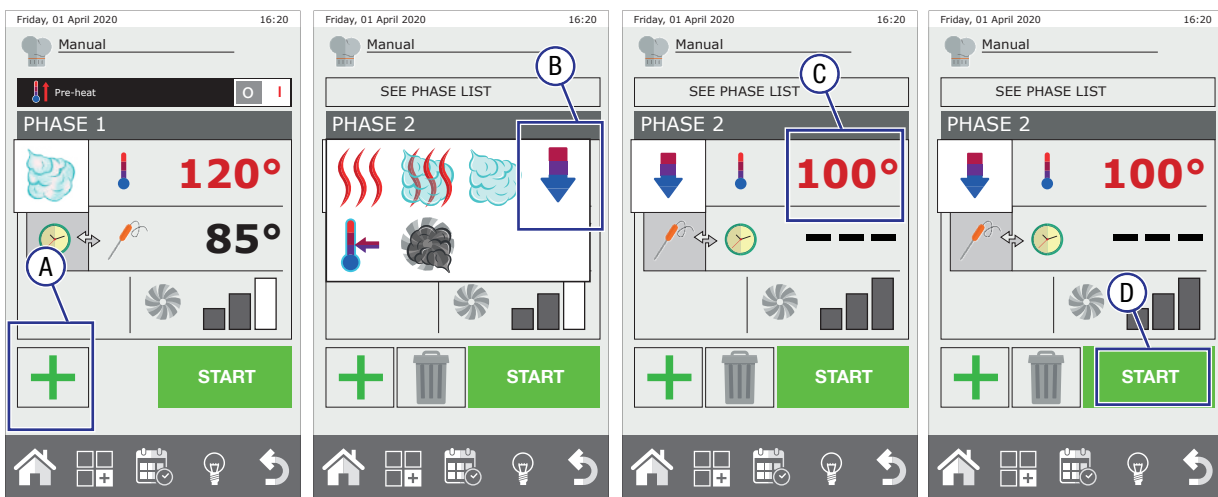

4.3.15 Smoking Phase

The “Smoker” is a separate unit, this is required when using a smoking phase. The smoker unit is placed into the oven on one of the trays (before the smoking phase begins).

If a cooking phase is to follow the smoking phase, the smoker unit must be removed from the oven (refer to the Smoker manual for further information regarding the connection and use of the smoker).

To set a holding phase:

- Select the cooking method “Smoking”
- Set the parameters (temp, time, fan speed etc.)
- Load product into the oven, press “Start” (press “+ NEW PHASE” if another phase is required)
- Before the program starts, the oven will display a message for the smoker unit to be introduced before the smoking phase begins. At the end of the smoking phases, the oven displays a message for the removal of the smoker unit. Both these messages must be confirmed by the operator. Only after confirmation will the oven begin the next phase (if programmed)

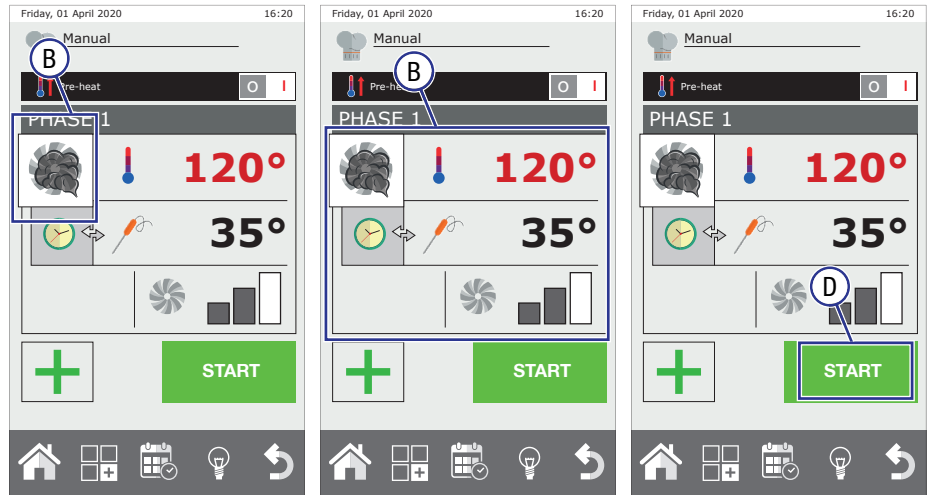

Note: The temperature, time, ventilation and humidity discharge valve can be adjusted during smoking. It is recommended to keep the humidity discharge valve closed so that smoke does not escape from the chamber.

4.3.16 To Delete a Phase

If required one or more phases can be deleted from the manual program.

- Touch the “See Phase List” to select the phase to be deleted
- Touch the “DEL PHASE” field. The phase is then removed from the list

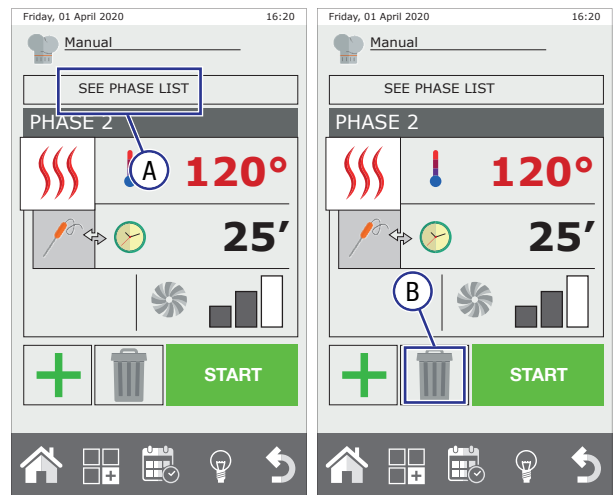

4.3.17 Saving a Recipe

Once the cooking program has been finalised (all required phases set), the cooking program can be saved. The cooking program needs to be assigned to one of the search parameters and named.

- A. Touch the settings field
- B. Touch “Save program”
- C. Touch “Save”
- D. Touch the search parameter for the cooking program to be assigned to e.g. “EXTRA” (this will help to find it easily in the future)
- E. Touch “FORWARD” to confirm
- F. Assign a name to the recipe using the keypad (e.g. “Lasagne”)
- G. Touch ENTER to confirm
- H. Depending on the type of cooking method selected, the display screen will show the option to change the type of colouring, humidity percentage or cooking level (e.g. cooking method: ROAST), Touch the symbol and set the desired value
- I. Turn the navigation dial to adjust the percentage value
- J. Press the navigation dial to save the set value

Note: The recipe can be started immediately by touching the “Start” key, or exit the window using the key, to be used later. Saved recipes, can be modified at any time (names / parameters). This will permanently overwrite the recipe.

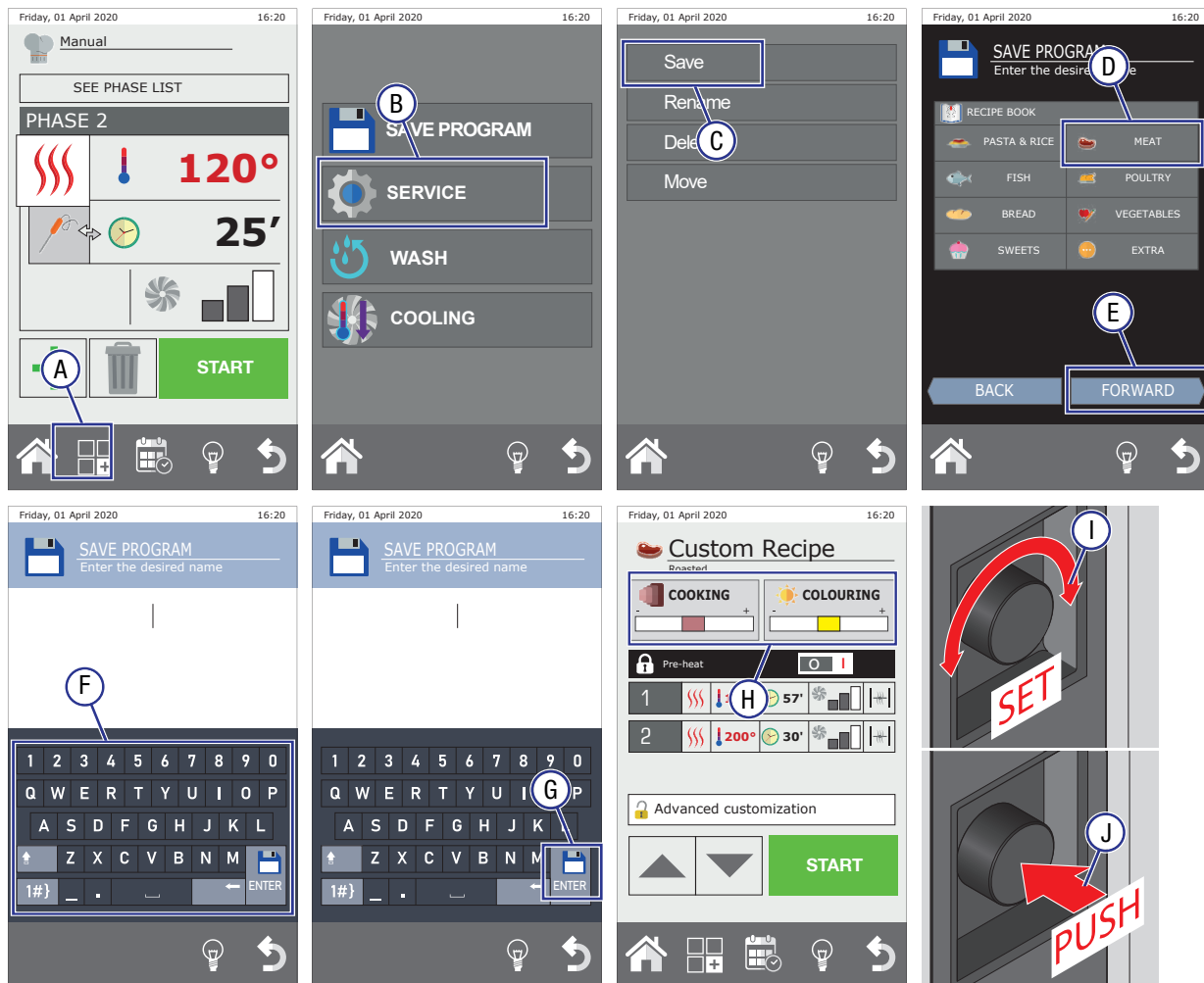

Due to continuous product research and development, the information contained herein is subject to change without notice.

4.3.18 Delete a Cooking Program

A saved manual cooking program can be deleted. This is done when the cooking program is open.

- Open the custom cooking program
- Touch the settings field
- Touch "Save program"
- Touch "Delete"
- Select Yes to delete the cooking program. Select No to cancel the function

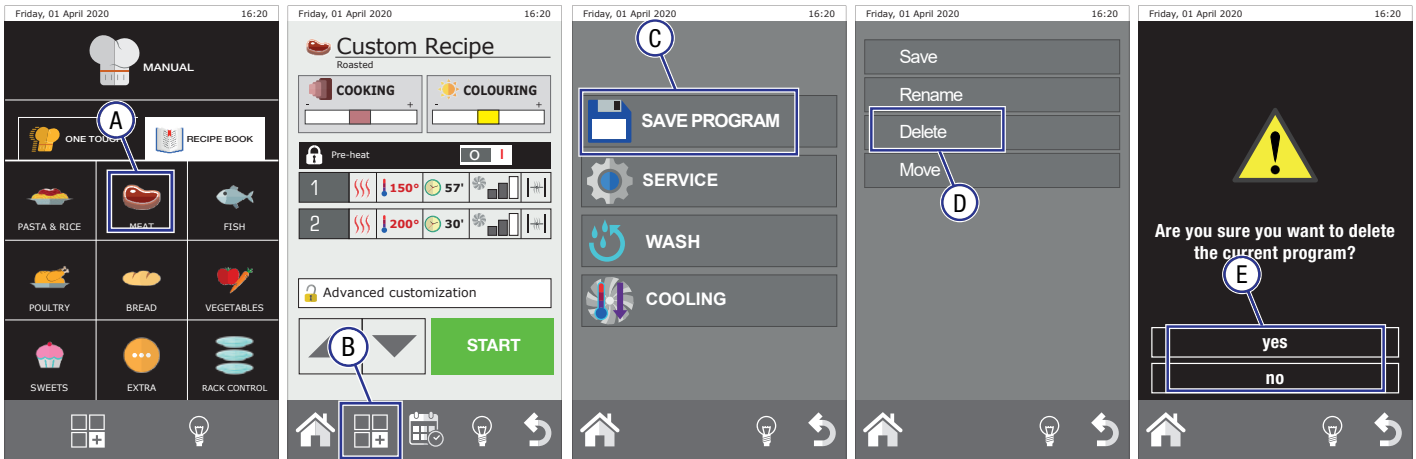

Rename a Cooking Program

A saved manual cooking program can be renamed. This is done when the cooking program is open.

- Open the custom cooking program
- Touch the settings field
- Touch "Save program"
- Touch "Rename"
- Assign a name to the recipe using the keypad (e.g. "Lasagne")
- Touch ENTER to confirm

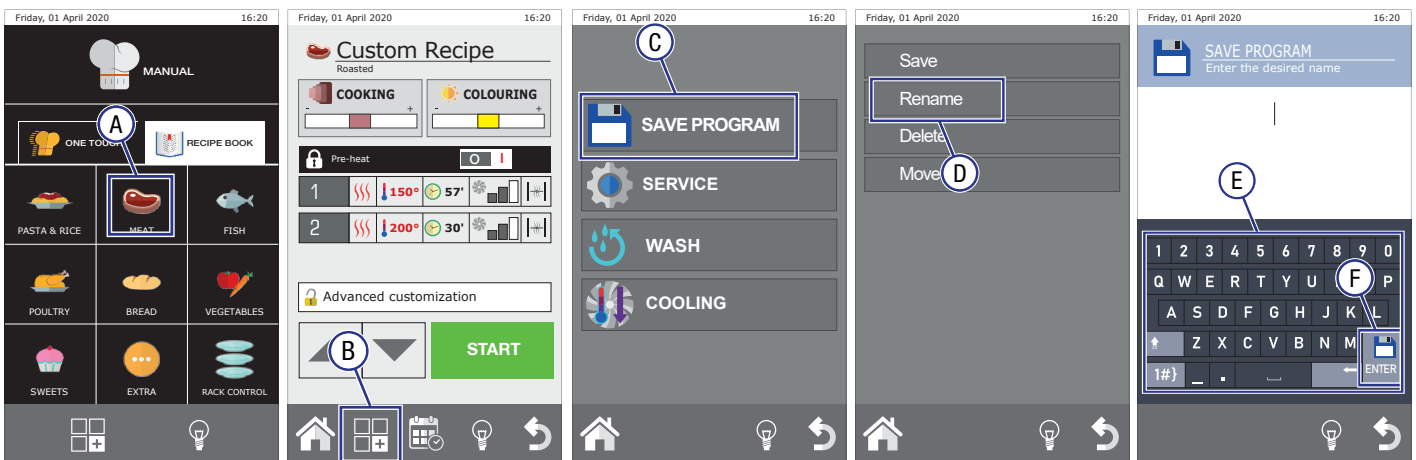

4.3.20 Move a Cooking Program

A saved manual cooking program can be moved to a new recipe book or cooking method. This is done when the cooking program is open.

- A. Open the custom cooking program
- B. Touch the settings field
- C. Touch “Save program”
- D. Touch “Move”
- E. Select the new location (e.g. “Roast”)
- F. Touch “Forward”
- G. The option to enter a new recipe name will be displayed. Assign new name to the recipe use the keypad (e.g. “Lasagne”) or skip to next step
- H. Touch “ENTER” to confirm the recipe name

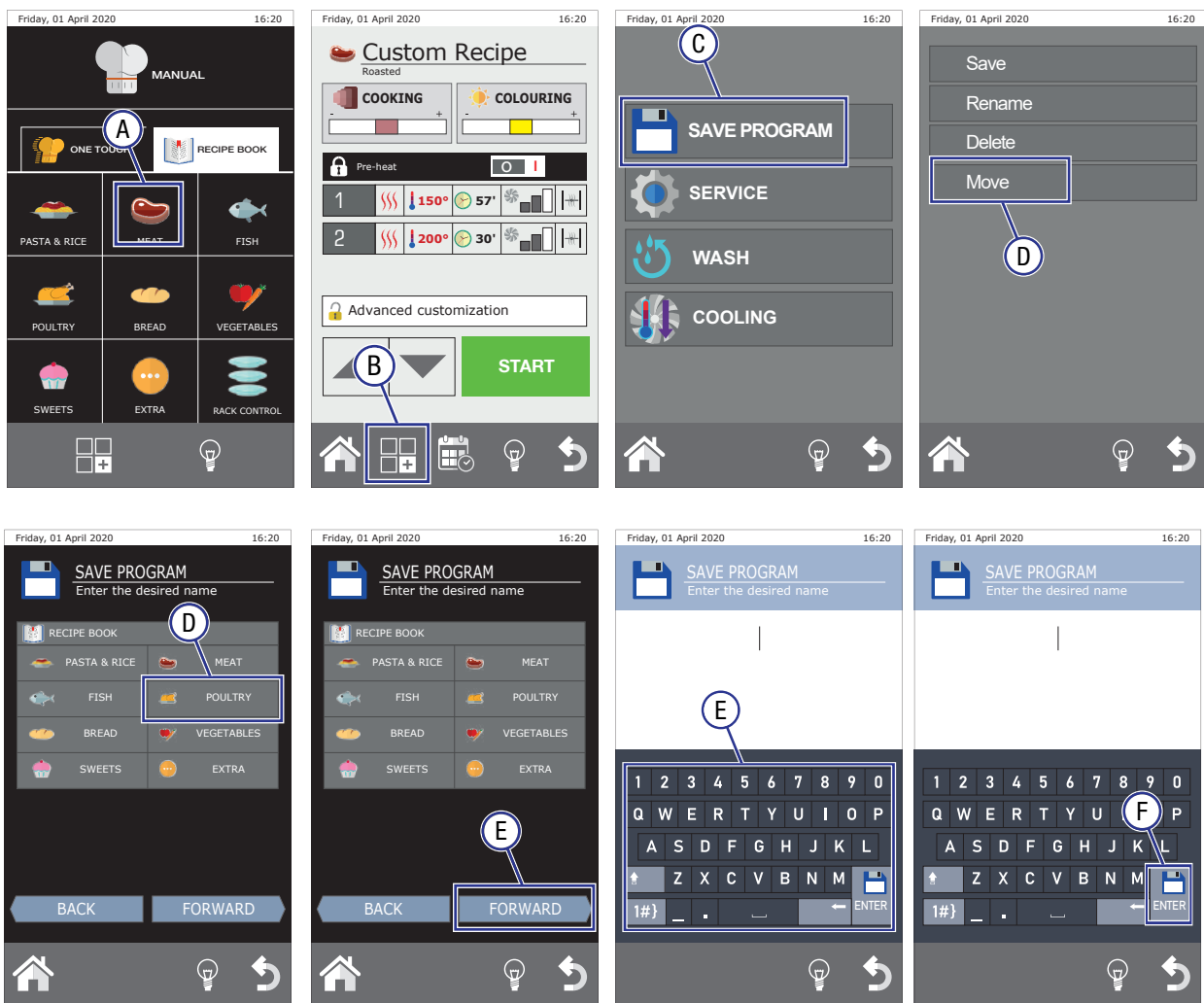

4.4 Automatic Cooking

4.4.1 Cooking Program Selection

Cooking programs can be categorised two ways, Cooking Methods or Recipe Book:

- Recipe Book, categorises the type of dish (e.g. Pasta & Rice, Meat, Poultry etc.)
- One Touch, a selection of 9 user selected recipes for quick access

To switch between these two search methods, touch the “Recipe Book” or “One Touch” field.



4.4.2 How To Use The Automatic Cooking Program

- Select the cooking method/category containing the recipe required (e.g. steam)
- Select the required recipe (e.g. Boiled beef)
- Based on the recipe, choose the colouring and/or the cooking level by touching the symbol and setting the desired value
- (Optional) Touch the “Advanced Customization” field, apply any required changes to the cooking phases parameters (e.g. temperature, fan speed).
 - Default Cooking Programs: The changes applied are temporary, i.e. only apply to the cooking cycle to be started
 - Custom Cooking Programs: The changes applied are permanent, i.e. the original program will be overwritten
- Begin the cooking cycle by touching “Start”

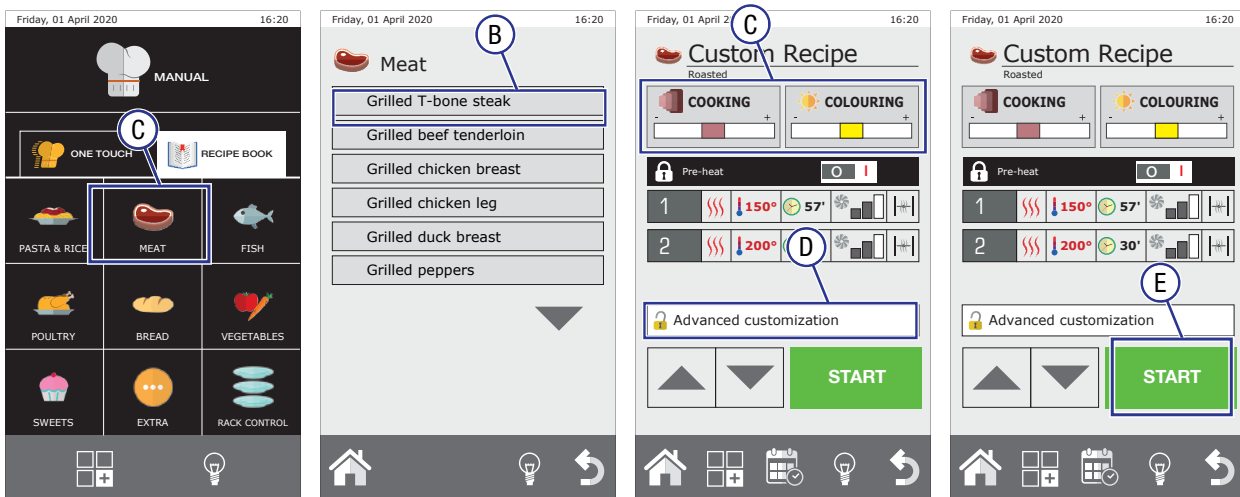

4.5 Special Automatic Cooking Programs

4.5.1 Rack Control - Manual Setting

Manually set timers for each tray (up to 6 or 10 depending on the oven model).

- Once cooking parameters have been set, up to 10 timers can be manually set (each one is assigned to a tray)
- Timers can be set by “Time” and/or one timer can be set using “Core Probe”
- As soon as the set time elapses (if duration is set by the time) or the core probe reaches the set temperature, an audible sound will be emitted and the message “End” will display to warn the operator about which trays are ready to be removed from the oven, while the others keep cooking (the oven runs in INFINITE MODE)

Manual Setting:

- Press “Rack Control”
- Select “Manual”
- Enter the cooking parameters
- Select a tray
- Select “Time” or “Core Probe”
- Turn the navigation dial to adjust the value
- Press the navigation dial to save the set value to the selected tray. Repeat for the required amount of trays
- Touch “Start” for the rack control to begin (the countdown timers start)
- Trays showing “END” can be removed from the oven



Due to continuous product research and development, the information contained herein is subject to change without notice.

4.5.2 Rack Control - Menu Setting

Pre-set menus (e.g. breakfast, multi-baker, etc.), where typical dishes are already loaded with timers already assigned

- Once the cooking parameters have been set, select a menu containing dishes with assigned timers. This allows the menu to be customised based on the users requirements
- As soon as the set time elapses (if duration is set by time) or the core probe reaches the set temperature, an audible sound will be emitted and the message “End” will display to warn the operator about which trays are ready to be removed from the oven, while the others keep cooking (the oven runs in INFINITE MODE)

Menu Setting:

- Touch “Rack Control”
- Select a customised menu e.g. “Breakfast”
- Enter the cooking parameters
- Select a tray
- Select a menu item to be assigned to the selected tray e.g. “Hash Browns”, or press “+NEW” to create a new menu item
Repeat for the required amount of trays
- Touch “Start” for the rack control to begin
- The countdown timers start. If needed the pre-set timers can be adjusted. Select the tray to be adjusted. Select “Time” or “Core Probe”
- Turn the navigation dial to adjust the value
- Press the navigation dial to save the set value to the selected tray
- The adjusted time is now displayed

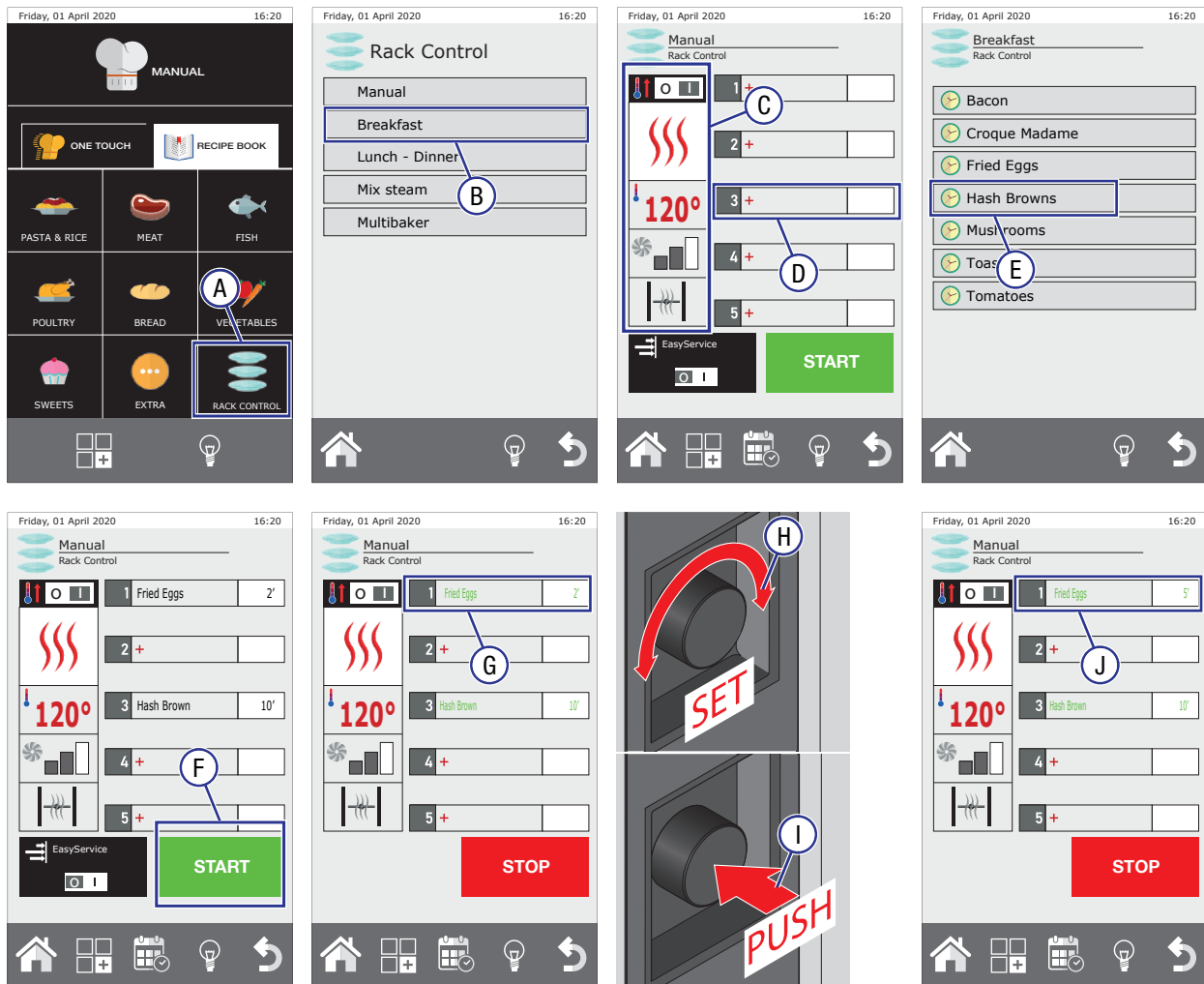

4.5.3 Rack Control - Easy Service

Once the cooking times for each tray have been set (see points - manual setting or menu setting), the EASY SERVICE function can also be selected.

In this case, the dishes will be ALL ready at the same time, as the oven will warn the operator when it is time to put a tray in the oven cavity, based on the duration of the cooking cycle set for each tray.

Easy Service Setting:

- A. Press "Rack Control"
- B. Select the customised menu e.g. "Breakfast"
- C. Enter the cooking parameters
- D. Select "Easy Service"
- E. Select menu items. Menu items will be assigned to trays in the order starting at 1 in the order selected
- F. Touch "Start" for the rack control to begin
- G. The countdown timers start. To have the trays ready at the same time, place the "IN" tray into the oven first (add each additional tray as required)

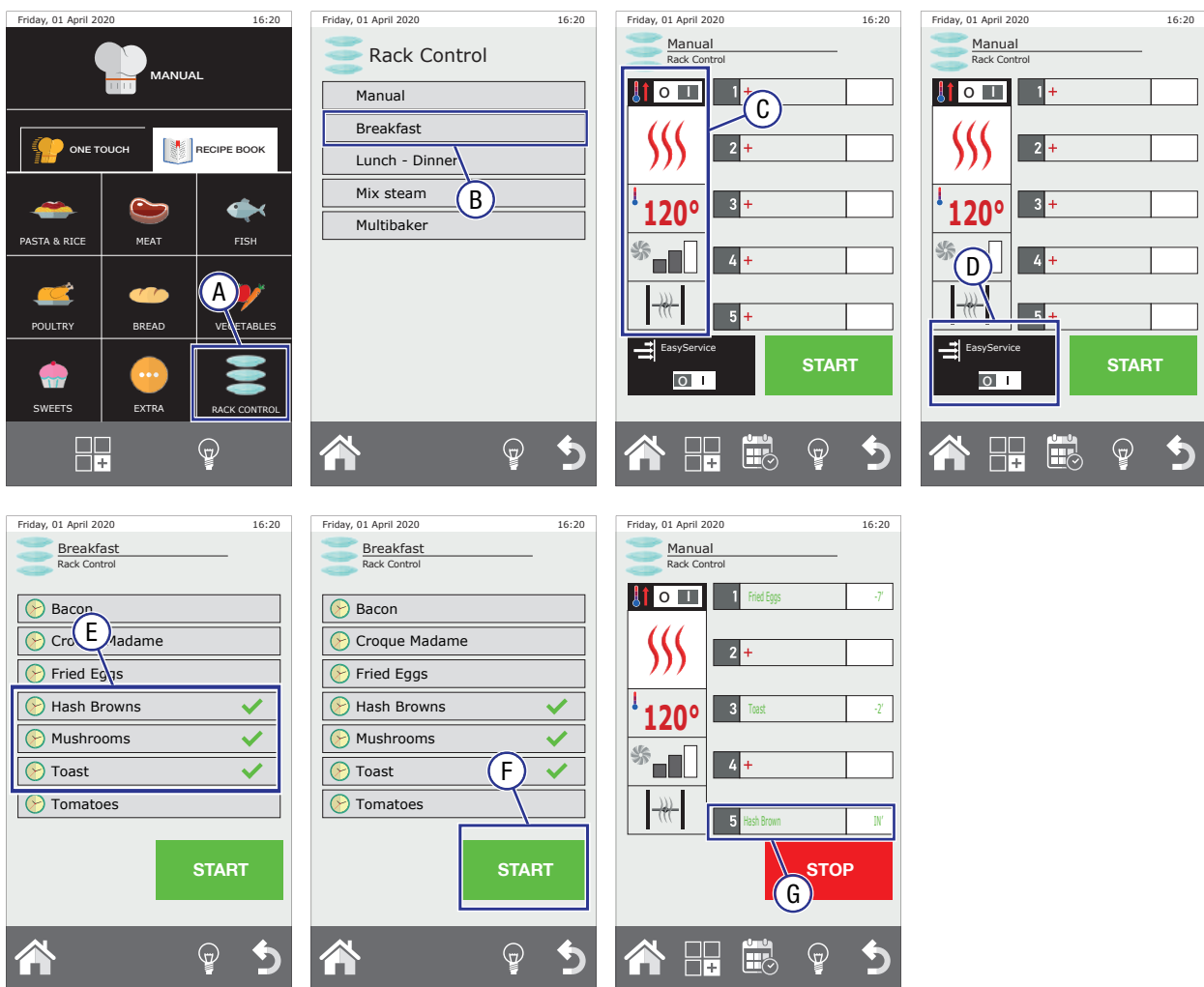

4.6 Special Functions

4.6.1 Cooling Of The Chamber

Before starting a recipe, the chamber can be cooled before cooking foods that require a lower temperatures or before a wash cycle. No function can be used when the cooling cycle is in progress.

The cooling cycle can be carried out with the door closed or open. It is recommend keeping the door closed until the temperature has dropped.

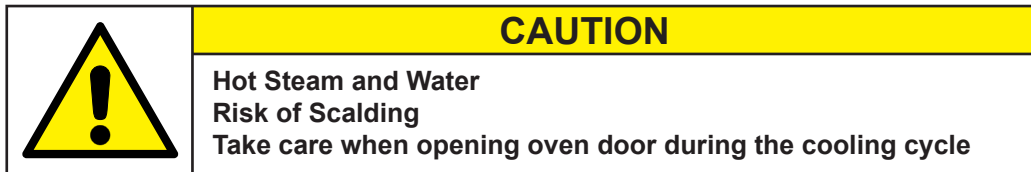

To cool the oven chamber:

- A. Touch the “Settings” icon
- B. Touch “Cooling”
- C. Touch “Start” to begin the cooling cycle

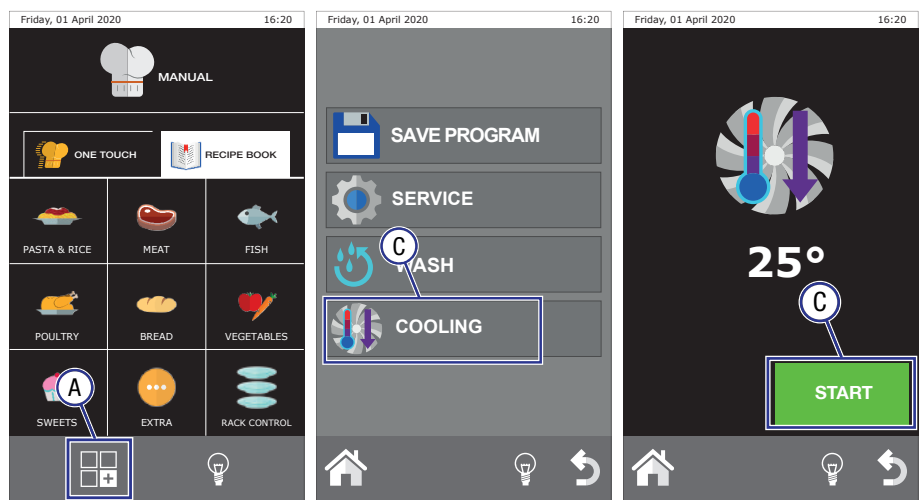

4.6.2 Delayed Start

If required, when setting a cooking program or once a recipe is open, a delayed start time can be set.

To set delayed start:

- A. Select the date and time icon
- B. Set the date and time for the delayed start to begin
- C. Press “OK” to confirm

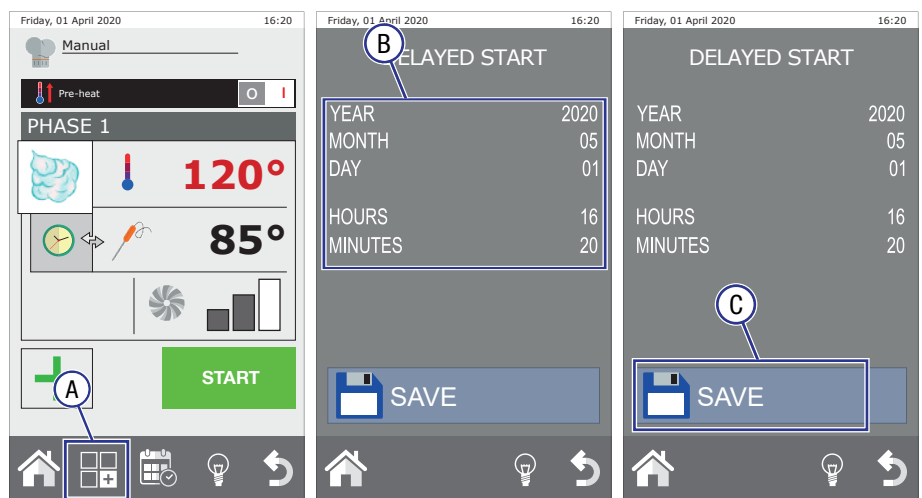

4.7 One Touch

One Touch saves time by accessing user preferred recipe. Save up to 9 cooking programs from either an existing program or user created program.

One Touch Setting:

- A. Press "One Touch"
- B. Press and hold an icon to allocate a recipe (saved recipes can be overwritten)
- C. Select a recipe from the recipe book
- D. Select the icon to associate the recipe
- E. The recipe program is now available in One Touch mode

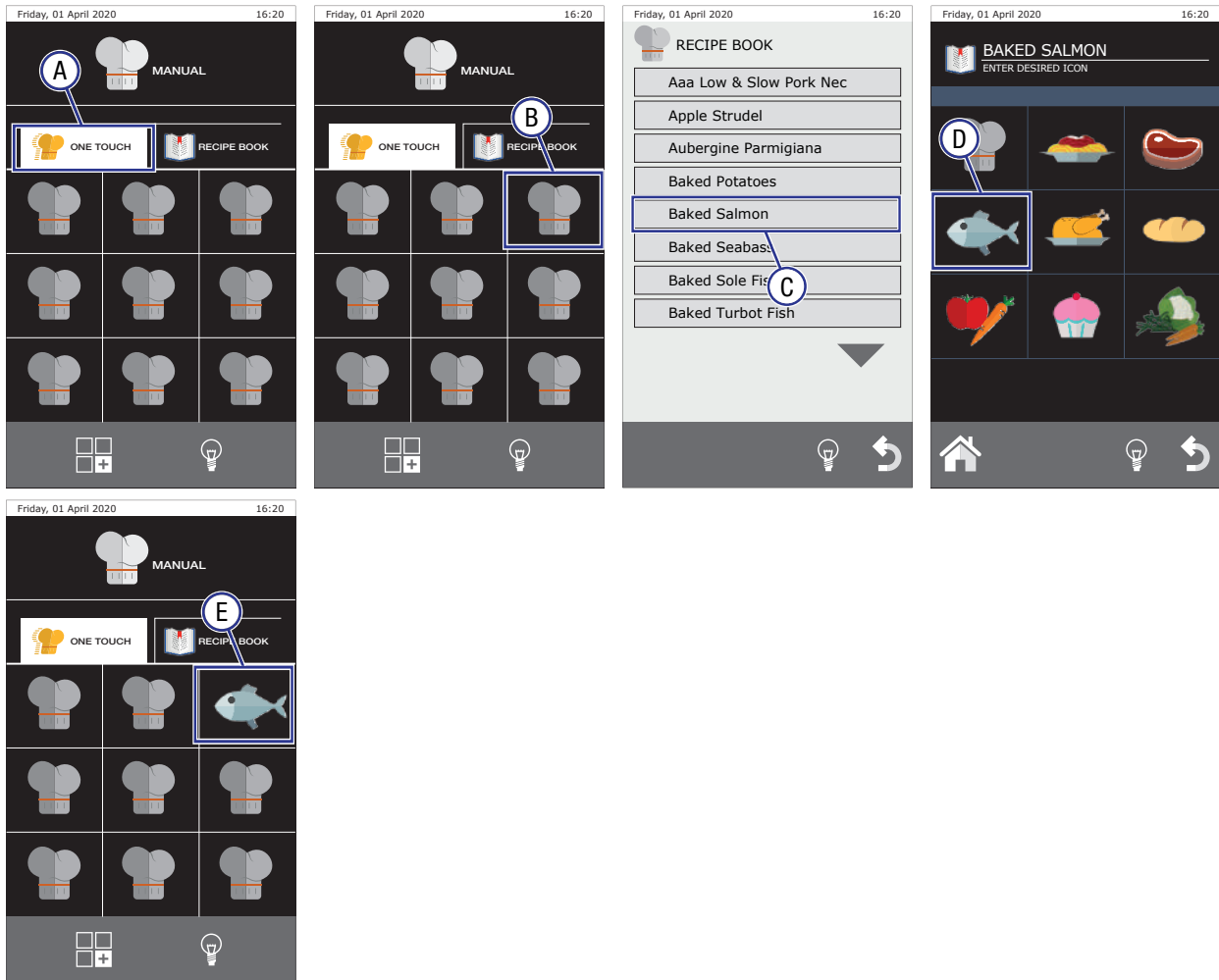

4.8 Importing / Exporting Recipes and Log To USB

Files can be imported/exported (in FAT32 format) to a USB stick. The USB port is on the underside of the front control panel of the oven
Recipes:

- Saved recipes, including altered default recipes can be imported or exported

Logs:

Logs are a list of the events occurred, e.g. wash logs provide information about the type of wash, date and time in which it was carried out.

- HACCP;
- Of the alarms triggered;
- Of the wash cycles carried out.

4.8.1 Import / Export

- Insert USB into the USB Port. Enter the settings menu
- Touch "Service"
- Touch "Import / Export"
- Select one of the options from the Import or Export menu. e.g. "Export Recipe Book"
- Touch "Start" to begin the file transfer to USB

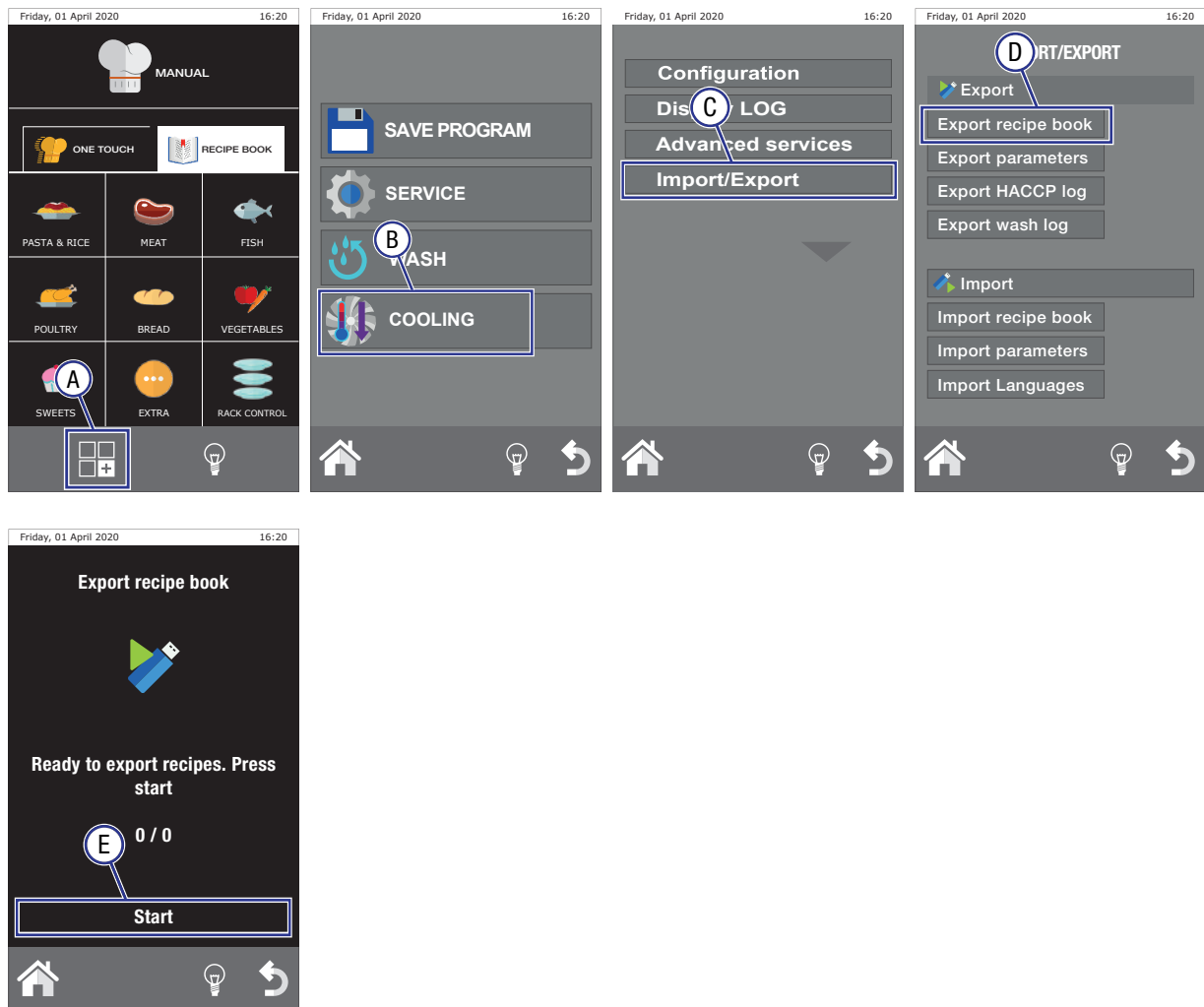

4.9 Display LOG

To display the Logs only:

- Enter the settings menu
- Touch "Service"
- Touch "Display Log"
- Select "Alarms Log" or "Wash Log"

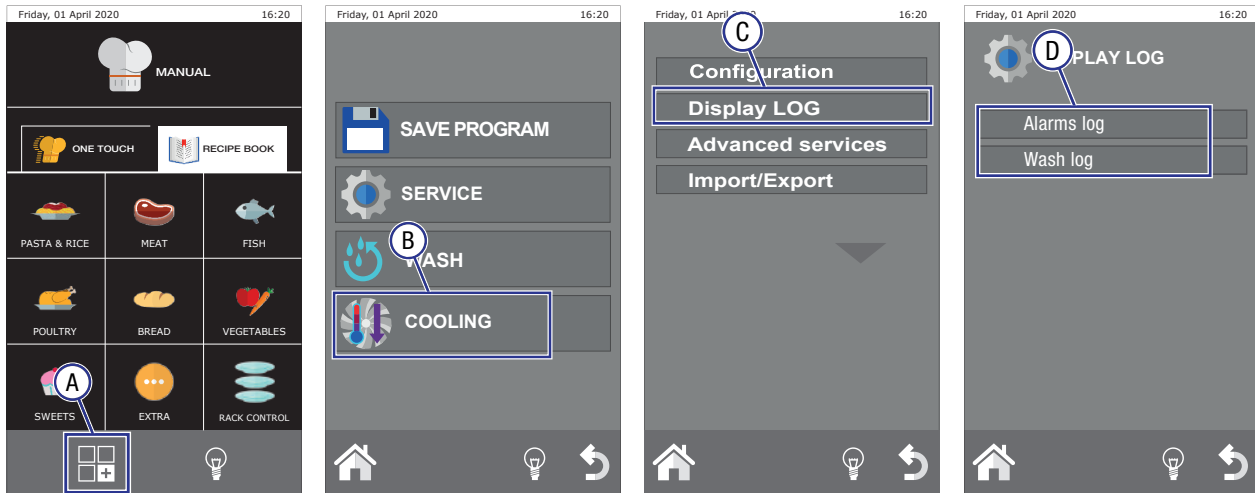





4.10 HACCP Protocol

HACCP (Hazard Analysis and Critical Control Points) is an internationally recognised method of identifying and managing food safety, through the use of preventative procedures that ensures hygiene and health in food.

This protocol begins with the analyses of the possible risks of bacterial, chemical and physical contamination in every stage of the food production process, including storage, distribution and consumption of the finished product.

HACCP identifies the critical points where contamination is more likely to occur. Based on these results, specific procedures are studied and applied to constantly monitor every stage of the food process to prevent hazards.

5.1 Cleaning

	<p style="text-align: center;">IMPORTANT</p> <p>Threaded fasteners can loosen in service. Regular inspection and adjustment should be carried out as required</p>		<p style="text-align: center;">WARNING</p> <p>This unit is NOT waterproof, do NOT hose. DO NOT pour water directly onto the unit. DO NOT immerse in water</p>
	<p style="text-align: center;">IMPORTANT</p> <p>Some commercial stainless steel cleaners leave residue or film on the metal that may entrap fine particles of food, deeming the surface not FOOD SAFE</p>		<p style="text-align: center;">WARNING</p> <p>Wait until the unit has cooled to a safe temperature before undertaking any cleaning or maintenance. Contact with hot surfaces can cause burns and serious injury</p>

5.1.1 General Information

- Cleaning is recommended for health and safety purposes and to prolong the life of the unit
- **DO NOT** use abrasive pads or cleaners on the stainless steel or any other metal parts of the unit
- **DO NOT** use industrial chemical cleaners, flammable cleaners, caustic based cleaners or bleaches and bleaching agents, as many will damage the metals and plastics used on this unit
- **DO NOT** remove any screws and/or panels for cleaning (unless directed)
- This unit is **NOT** waterproof, **DO NOT** hose, **DO NOT** pour water directly onto the unit, **DO NOT** immerse in water

5.1.2 Corrosion Protection

- Stainless steel exhibits good resistance to corrosion however, if not properly maintained stainless steel can rust and/or corrode
- Any sign of mild rust and/or corrosion should be thoroughly cleaned with warm soapy water and dried as soon as possible
- NEVER use abrasive pads or cleaners for cleaning
- All metal surfaces should be checked while cleaning for damage, scuffs or scrapes as these can lead to rust and further damage to the product
- Mild rust and/or corrosion can be treated with a commercial cleaning agent that contains citric/oxalic/nitric/phosphoric acid. **DO NOT** use cleaning agents with chlorines or other harsh chemicals as this can cause corrosion. After treatment, wash with warm (not hot) soapy water and dry thoroughly
- Thoroughly wipe the surfaces dry after cleaning. **DO NOT** let water pool on the unit. Check crevices and folds for pooling
- When using, ensure all liquids and moisture is cleaned up straight away. Food liquids such as juices from vegetables and fruits should not be left on any surfaces
- **DO NOT** leave items on the stainless steel such as cutting boards, rubber mats and bottles

5.1.3 Surface Finish

- To protect the polished surface of the stainless steel, it should be dried using a clean dry soft cloth. A light oil can be applied to enhance the stainless steel surface, using a clean cloth apply the oil in the same direction as grained polished finish
- Some commercial stainless steel cleaners can leave residue or film on the metal; this may trap fine particles of food on the surface, thus deeming the surfaces not food safe

5.0 Cleaning and Maintenance

5.1.4 Cleaning and Maintenance Schedule

For good kitchen hygiene, the oven should be visually inspected by management at least once per week. The below 'Cleaning and Maintenance Schedule' provide a cleaning guide for Extreme, Heavy and Light duty operation.

Additionally, a service technician is required to perform the Scheduled Maintenance Services (refer to page 62)

- Daily cleaning is required for the oven, to help maintain and prolong the efficiency of the oven
- The oven should be cleaned at the end of each work day
- DO NOT USE: Wire brushes, steel wool/sponges, scrapers or other abrasive materials
- Wait for the oven chamber to cool down before cleaning. Must be under 100°C

This schedule is a guide only.

Item	Daily	Weekly	1 Month	3 Months	6 Months	12 Months
5.1.6 Cleaning External Surfaces	X					
5.1.7 Cleaning Internal Cavity	X					
5.1.8 Cleaning Glass Door	X					
5.1.9 Cleaning Internal Rack	X					
5.1.10 Inspect Door Seal			X			
5.1.11 Inspect Light Switch			X			
5.1.12 Control Panel Ventilation Filter			X			
5.2 Automatic Cleaning	X					
5.3 Boiler Descaling				X		
5.5 Water Filtration				X	X	X

Item	0 hours 1 month	2500 hours 12 months	5000 hours 24 months	7500 hours 36 months	10000 hours 48 months
Initial Inspection	X				
Scheduled maintenance service		X			
Scheduled maintenance service			X		
Scheduled maintenance service				X	
Scheduled maintenance service					X

5.1.5 Materials Required

- Stainless Steel Cleaner
- Non Abrasive Cleaning pad
- Clean Sanitised Cloth
- Warm soapy water
- Appropriate PPE (Personal Protective Equipment)

5.1.6 Cleaning External Surfaces

1. The oven exterior should never be cleaned with direct water or high pressure jets
2. Wipe clean using a cloth dampened with clean warm soapy water until all has been removed
3. Scrub any baked on soil with the cleaner pad in the same direction as grained polished finish. **Do not scrub the display panel**
4. Wipe clean using a cloth dampened with clean warm water until all Stainless Cleaner and soil has been removed
5. Using a clean sanitised cloth, thoroughly wipe the stainless steel and metal parts dry. Do NOT let water pool on the unit. Check crevices and folds

5.1.7 Cleaning Internal Cavity

Before running the automatic cleaning cycle the oven may require large soil/waste to be manually removed

1. Remove any loose soil from the oven cavity and around the drain using a clean damp cloth
2. Remove the drain can cover and dispose of soil. Do not push/force solid waste into the drain. This is to prevent blockages and possible back-flow
3. Re-insert the drain cover

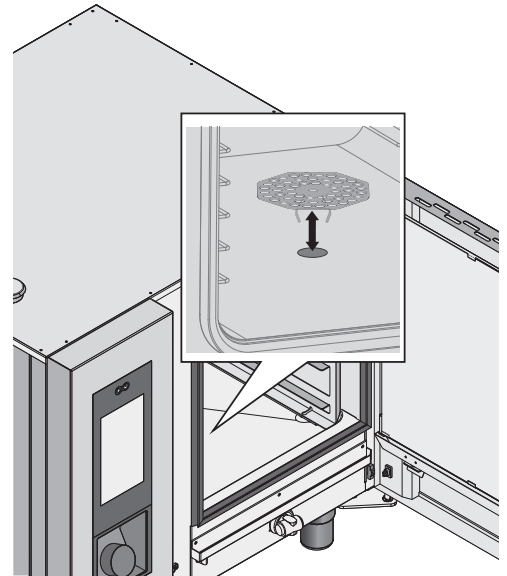

5.1.8 Humidity Discharge

The humidity discharge expels the vapours produced inside the cooking chamber. Check that it is always perfectly clean and free from obstructions.

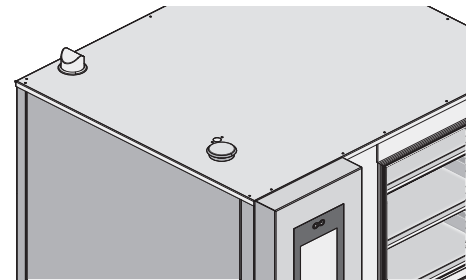

5.1.9 Cleaning Glass Door

The door glass can be cleaned both on the outside and on the inside.

1. Rotate the two latches that lock the internal glass door
2. Swing internal glass door open
3. Check and confirm inner door glass bumpers are in-place and tensioned to prevent the glass from vibrating. Rotate to adjust
4. Clean with warm soapy water and a clean cloth Never use abrasive materials
5. Close the glass door, rotate the two latches back into position

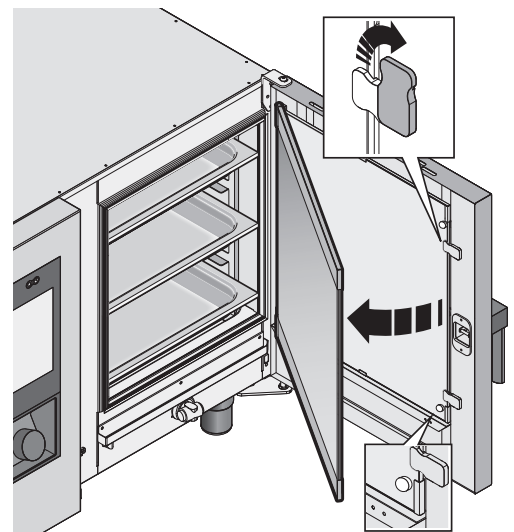

5.0 Cleaning and Maintenance

5.1.10 Cleaning Internal Rack

Normally, the automatic wash cycles clean internal racks effectively. However if required, these can be easily removed.

1. Pull the two rack locking levers forward
2. Pull the rack sideways then remove from the oven cavity
3. Clean using warm soapy water, rinse thoroughly and dry
4. Re-install into the oven, ensure the rack locking levers are pushed back into position

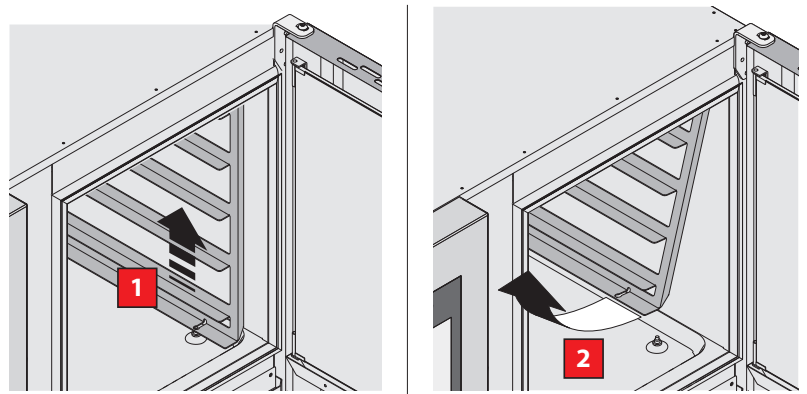

5.1.11 Control panel ventilation filter

The oven control panel ventilation filter (F) must be cleaned minimum once a month.

1. Slide the filter down to remove
2. Wash with clean warm soapy water
3. Ensure filter is dry before reinstalling

The filter should be replaced annually or as required.

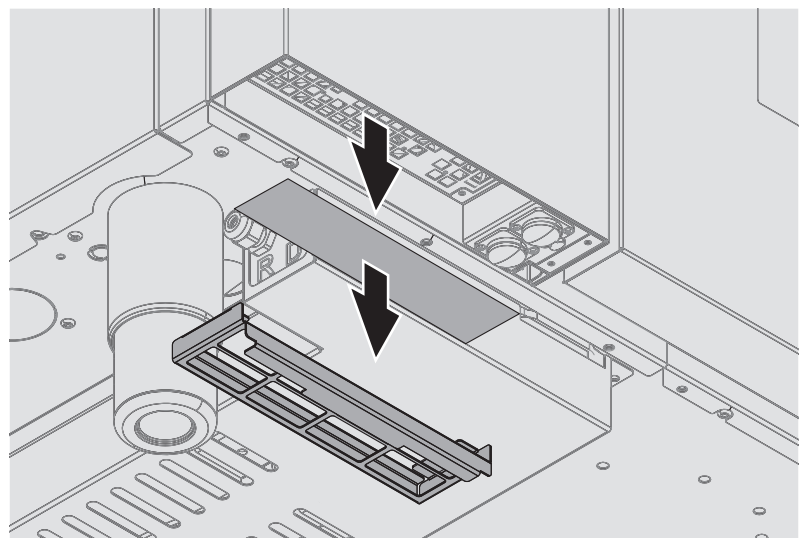

5.1.12 Rinse Head

Periodically remove the rinse head and leave it immersed in a solution of water and vinegar for 4hrs (longer if required). Rinse thoroughly and dry. Re-install rinse head

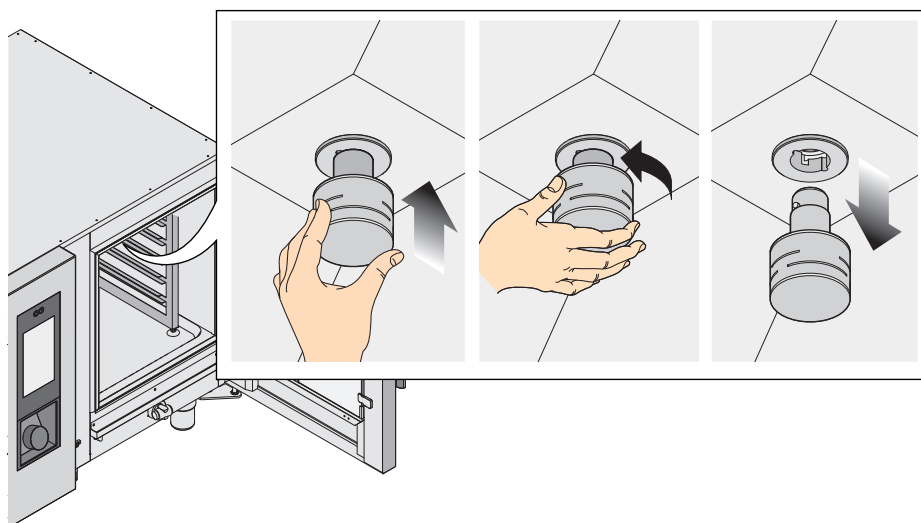

5.1.13 Inspect Door Seal

1. Clean the door gasket with a clean damp cloth
2. Check the door seal for any splits

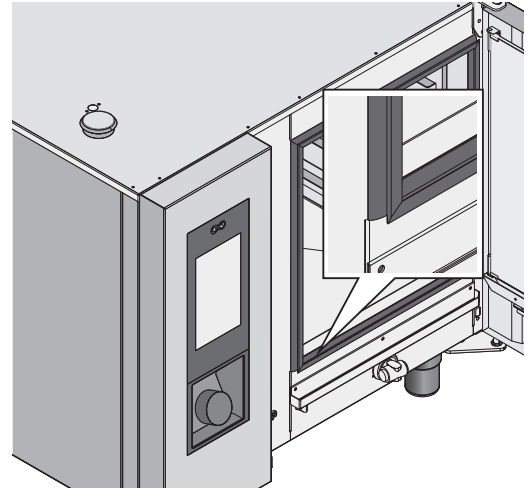

5.1.14 Inspect Light Switch

1. Clean the door light switch with a clean damp cloth, ensure there is no soil on the contact points

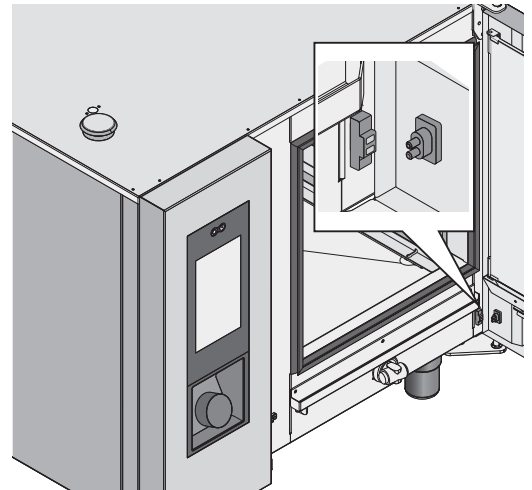

5.2 Automatic Cleaning

5.2.1 Wash Times 6 - 10 Tray

There are four options when selecting a automatic wash program.

SOFT		48 minutes	light dirt
NORMAL		53 minutes	normal dirt
HARD		58 minutes	intense dirt
RINSING PROGRAM	The rinse program does not involve the use of detergents		

5.2.2 Wash Times 20 - 40 Tray

There are four options when selecting a automatic wash program.

SOFT		65 - 75 minutes	light dirt
NORMAL		1 hour and 30 minutes	normal dirt
HARD		1 hour and 50 minutes (wash tablets) 2 hour and 35 minutes (wash using a liquid detergent)	intense dirt
RINSING PROGRAM	The rinse program does not involve the use of detergents but you can decide whether to use the rinse agent or not.		

5.2.3 Wash Selection

To select a automatic wash program.

- Enter the settings menu
- Touch "Wash"
- Select appropriate wash program e.g. Hard Wash
- Press "Start"

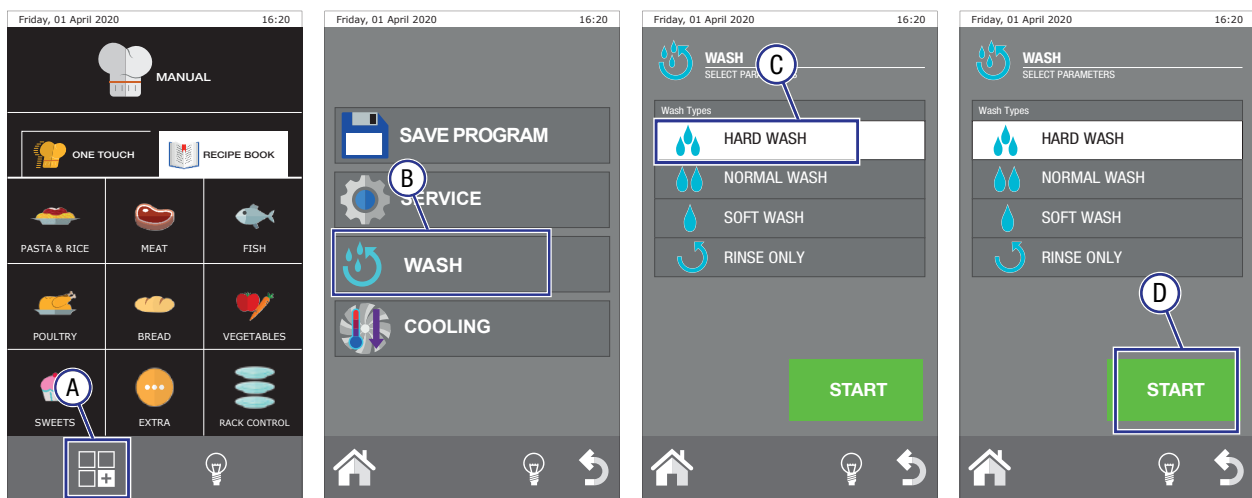

Note: Stoddart recommends using the Stoddart supplied detergent, specific for your oven. Use of non-approved or recommended chemical will void warranty.

5.2.2 Start the Wash Program

	IMPORTANT
	<p>During a wash cycle, do not open the oven's door: Risk of injuries and intoxication due to vapours</p>

Start the wash program by touching “Start”

Depending on the options selected, some windows will prompt the operator to clean the chamber gasket using a soaked cloth and check the level of detergent.

- If the detergent and/or rinse agent tanks need to be replaced, select the relative key:

 Detergent replaced	The liquid detergent tank has been replaced
--	---

- A window will indicate the progress of the wash program (divided into four stages):

Pre-wash	A “wet” steam phase is carried out without using a detergent to soften coarse residue.
Wash	The wash cycle using a detergent
Rinse	Rinsing of the chamber to remove any trace of detergent.
Drying	Air drying the oven chamber.

Note: If regularly cooking with fatty foods (e.g. pork roast, roasts, etc.), between one cooking cycle and another, it is recommend to start the rinse program to facilitate the final cleaning procedure and ensure the utmost hygiene.

5.2.3 Stop the Wash Program

In certain circumstances the wash cycle may need to be stopped.

The wash cycle can only be stopped at certain stages:

Pre-wash	STOP ALLOWED Press “Stop”
Wash	STOP ALLOWED Press “Stop”. The oven automatically switches to a rinse phase, which cannot be stopped.
Rinse	STOP NOT ALLOWED
Drying	STOP ALLOWED Press “Stop”. The wash cycle stops immediately

Note: If during a wash cycle the power to the oven is disconnected (e.g. power outage, turned off at supply) for a period less than two minutes, the oven will automatically resume the wash cycle when the power is restored.

If during a wash cycle the power to the oven is disconnected (e.g. power outage, turned off at supply) for a period longer than two minutes, when the power is restored, a message will be displayed about the power outage and a audible sound is emitted. A rinse will automatically start this cannot be stopped.

5.3 Liquid Detergent Connection

	IMPORTANT
	Only Stoddart provided oven cleaners should be used. Other products may lead to voidance of warranty!

Detergent line located on the underside of the oven

- If using the optional Stoddart bottle holder, place the holder on the outside of the grid rack
- Remove the bottle cap from the liquid detergent
- Drill a 8mm hole in the centre of the cap
- Feed the detergent line through the bottle cap
- Attach the weight to the detergent line
- Place the line and weight back into the bottle and secure bottle cap
- Cleaning products must not exceed 10% Sodium Hydroxide. Exceeding 10% Sodium Hydroxide will void warranty
- Wear appropriate PPE

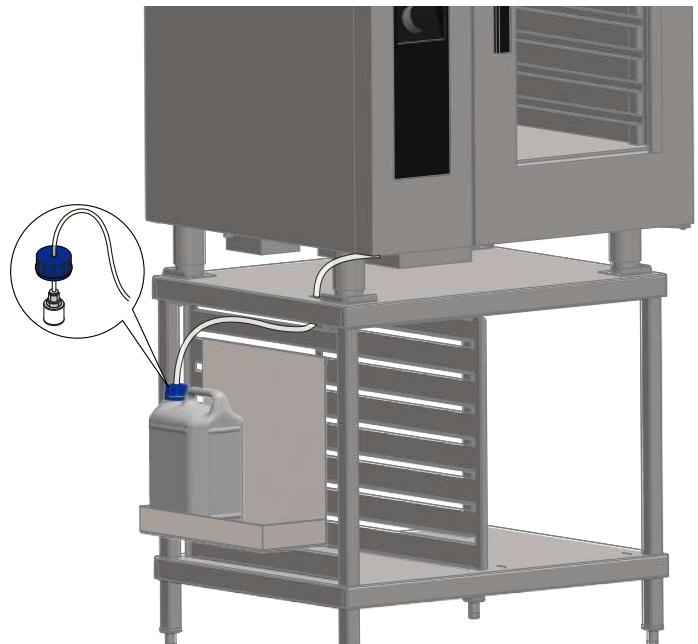

5.4 Water Filtration

- Water filtration is critical to the performance of the oven. Users must establish a regular filter replacement schedule. Required frequency will depend on the water quality and type of filtration system
- Filter change frequencies below are indicative minimums. If water quality is poor, the filter may need to be replaced more frequently
- Indicators that filters may require changing are:
 - Surface corrosion present in the oven cavity. Contact Stoddart for advice
 - Scale building up more frequently than normal
 - Oven starving for water creating error messages

5.5 Troubleshooting

5.5.1 Common Problems

In the event of severe failure, it is essential to turn isolate the unit from the power supply and close the water shut-off valve.

PROBLEM	POSSIBLE SOLUTION
The oven does not start.	Check that the power supply is turned on
	Make sure the oven door is properly closed
	Make sure the parameters of the cooking cycle have been set correctly
	Make sure the oven does not have any error messages displayed
	If the problem persists, Contact the Stoddart service department
The fans stops during operation.	Turn off the oven and wait for the thermal breaker of the motor to be restored automatically
	Make sure the cooling vents are not obstructed
	If the problem persists, Contact the Stoddart service department
Internal lighting is not working	Contact the Stoddart service department
Water is not delivered from humidifier pipes	Check that the water shut-off valve is open
	If the problem persists, Contact the Stoddart service department

5.5.2 Door Micro Switch

The door micro-switch is the device which stops the cooking cycle of the oven when the door is opened. Once the door is closed, the regular cycle is resumed. Do not operate this device manually with the oven door open.

5.5.3 Motor Thermal Breaker

The fan motor is equipped with a built-in thermal protection which stops operation in case of overheating. The motor restarts automatically as soon as its temperature is lowered, returning within the safety range.

5.5.4 Safety Thermostat Of The Oven Chamber

If the temperature in the oven chamber reaches 350°C, the thermostat disconnects the power supply to the heating elements of the oven. This safety device can be reset only by a qualified support service technician because it requires further checks.

5.5.5 Technical Problems / Alarm Code

ALARM	DESCRIPTION	ACTION	SOLUTIONS
E000 - Chamber probe failure	Cooking chamber temperature detection probe failure	Cooking stopped.	Contact the Stoddart service department
E003 - Inverter alarm	Motor control board alarm.	Cooking stopped.	Contact the Stoddart service department
E001 - Motor safety 1	Oven motor thermal safety alarm (higher if 2)	Cooking stopped. Automatic reset	Contact the Stoddart service department
E002 - Chamber safety	Oven cooking chamber over-temperature thermal safety alarm	Cooking stopped. Manual reset by authorised technician	Contact the Stoddart service department
E008 - PWM Communication	Communication error with PWM burner control board	Cooking stopped. Manual reset	Contact the Stoddart service department
E006 - Motor safety 2	Lower oven motor thermal safety alarm	Cooking stopped. Automatic reset	Contact the Stoddart service department
E004 - Electronic board temperature alarm - CLEAN THE FILTER	Oven board over-temperature alarm	Cooking stopped.	Clean the technical compartment instrument panel filter (fig. 47). Do not disconnect the oven's external power supply. If the problem persists, contact the technical support service or your local retailer.

5.0 Cleaning and Maintenance

ALARM	DESCRIPTION	ACTION	SOLUTIONS
E030 - Electronic board temperature pre-alarm - CLEAN THE FILTER!	Oven board over-temperature pre-alarm	Cooking stopped. Manual reset	Clean the technical compartment instrument panel filter (fig. 47). Do not disconnect the oven's external power supply. If the problem persists, contact the technical support service or your local retailer.
E005 - No communication with the base	Serial communication problems between the touch board and the base board	Cooking stopped.	"Switch the appliance off and on again. If the problem persists, contact the technical support service or your local retailer"
E031 - Core probe failure	Core probe detection problems	Cooking stopped. Automatic reset	"Make sure you have inserted the core probe into the connector. If the problem persists, contact the technical support service or your local retailer"
E032 - No power.	No external power supply	Cooking stopped. Manual reset	Press the knob to reset the alarm. Check if a power outage occurred. If the problem persists: Contact the technical support service or your local retailer
E038 - Flow meter failure	No wash water alarm	Wash block. Manual reset	"Check that the water is turned on at the tap. Press the knob to reset the alarm. Contact the technical support service or your local retailer"
E034 - Air Flow Alarm 1	Pressure switch problem burner air safety	Cooking stopped. Manual reset	Check that the flue gas outlet duct is free. Press the knob to reset. If the problem persists, contact the customer support service
E036 - PWM 1	Problem with burner fan speed control system	Cooking stopped. Manual reset	"Press the knob to reset; remove and restore external power to the oven. If the problem persists, contact the customer support service"
E009 - PWM 2 Communication	Problem with digital communication with burner fan speed control board	Cooking stopped. Manual reset	"Press the knob to reset; remove and restore external power to the oven. If the problem persists, contact the customer support service"
E023 - No gas alarm	Failed start-up and/or burner flame detection	Cooking stopped. Manual reset	"Make sure that the oven is receiving gas (check that the gas shut-off valve and solenoid valves to the oven are open and active). Check that PHASE and NEUTRAL have not been swapped by accident in the power supply (have a technician check that there is a voltage of 230V between the oven body (earth) and the phase). Push the knob for at least one second to reset (it may be necessary to repeat the operation several times). If the problem persists, contact support."
E035 - Air Flow 2 Alarm	Pressure switch problem burner air safety	Cooking stopped. Manual reset	Check that the flue gas outlet duct is free. Press the knob to reset. If the problem persists, contact the customer support service
E039 - PWM 2	Problem with burner fan speed control system	Cooking stopped. Manual reset	"Press the knob to reset; remove and restore external power to the oven. If the problem persists, contact the customer support service"
E033 - No gas alarm 2	Failed start-up and/or burner flame detection	Cooking stopped. Manual reset	"Make sure that the oven is receiving gas (check that the gas shut-off valve and solenoid valves to the oven are open and active). Make sure that PHASE and NEUTRAL have not been swapped by accident in the power supply (have a technician check that there is a voltage of 230V between the oven body (earth) and the phase). Push the knob for at least one second to reset (it may be necessary to repeat the operation several times). If the problem persists, contact support."

5.6 Accessories and Consumables**5.6.1 Spare Parts**

Contact the Stoddart Spare Parts department to place an order.

Australia

Email: spares@stoddart.com.au

Tel: 1300 307 289

New Zealand

Email: spares@stoddart.co.nz

Tel: 0800 935 714

Code	Description
SPGI.7080533	Giorik Liquid Descaler and Rinse Aid - 3 x 5 Litre
CNCL.0105	Combi Foam Oven Cleaner - 3 x 5 Litre (liquid chemical)
SPGI.SMK01	Digital Smoker
SPGI.6000129	Sous Vide Probe
SPGI.CBH.002	Wall Mount Bracket (liquid chemical)
SPGI.CBH.001	Side Stand mounting (liquid chemical)

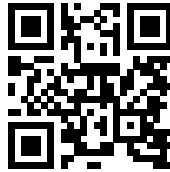

Online Order

5.0 Cleaning and Maintenance



5.7 Scheduled Maintenance Service History

To ensure the continued performance and reliability of this oven, routine maintenance and servicing are required at specific time intervals. Contact the Stoddart Service Department to book a service.

Australia

Email: service@stoddart.com.au
Tel: 1300 307 289

New Zealand

Email: service@stoddart.co.nz
Tel: 0800 935 714

5.6.1 Service Log

Initial Inspection

0 - 1 month

Date:

Hours:

Technician:

Scheduled maintenance service

2500hours / 12months (whichever occurs first)

Date:

Hours:

Technician:

Scheduled maintenance service

5000hours / 24months (whichever occurs first)

Date:

Hours:

Technician:

Scheduled maintenance service

7500hours / 36months (whichever occurs first)

Date:

Hours:

Technician:

Scheduled maintenance service

10000hours / 48months (whichever occurs first)

Date:

Hours:

Technician:

Due to continuous product research and development, the information contained herein is subject to change without notice.

Australia

Australian Business Number: 16009690251

Service / Spare Parts

<https://customerservice.stoddart.com.au>

Sales

Tel: 1300 79 1954

Email: sales@stoddart.com.au

Web: www.stoddart.com.au

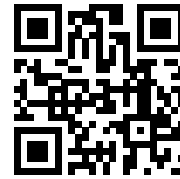

Customer
Service Portal

New Zealand

New Zealand Business Number: 6837694

Service / Spare Parts

<https://customerservice.stoddart.com.au>

Sales

Tel: 0800 79 1954

Email: sales@stoddart.co.nz

Web: www.stoddart.co.nz

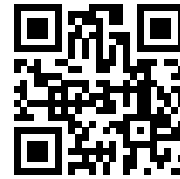

Customer
Service Portal



WMTS-101
WM-022773