

## SPECIFICATION, INSTALLATION AND OPERATION MANUAL

READ ALL INSTRUCTIONS BEFORE USE

### BAIN MARIE HOT CUPBOARD - COUNTER LINE / UNDER BENCH



**Models:**

CH.BMHC.U.GSF.3 / CH.BMHC.U.GSF.4 / CH.BMHC.U.GSF.5 / CH.BMHC.U.GSF.6 / CH.BMHC.U.GSF.7 / CH.BMHC.U.GSF.8  
(Includes Radius Well Models)

A guide on the use, care and maintenance  
of your quality Culinaire product

**Page Intentionally Left Blank**

## 1.0 Introduction

1.1 Your New Culinaire Product . . . . .	3
1.2 Australia and New Zealand Warranty . . . . .	4
1.2.1 Warranty Period	
1.2.2 Warranty Registration	
1.3 General Precautions . . . . .	4

## 2.0 Installation

2.1 Important Information . . . . .	5
2.2 Product Overview. . . . .	6
2.3 Setting Up . . . . .	7
2.3.1 Handling	
2.3.2 Unpacking	
2.3.3 Positioning	
2.4 Plumbing Connections . . . . .	8
2.4.1 Specification	
2.5 Electrical Connection . . . . .	9
2.6 Shelves. . . . .	9
2.6.1 Shelf Adjustment	
2.7 Under Counter Bain Marie . . . . .	10
2.7.1 Well Opening Sizes	
2.8 Bain Marie Element Covers & Dividers . . . . .	10
2.8.1 Bain Marie Element Covers	
2.8.2 Bain Marie Dividers	

## 3.0 Specification

3.1 Bain Marie - Undercounter . . . . .	11
---	----

## 4.0 Operation

4.1 Initial Start-up & Operation . . . . .	12
4.1.1 Control Panel	
4.1.2 Initial Start-up	
4.1.3 Using as a Wet Unit	
4.1.4 Using as a Dry Unit	
4.1.5 Loading Bain Marie	
4.1.6 Loading Hot Cupboard	
4.1.7 Loading Restrictions	
4.1.6 After Service Period	
4.2 Food Safety. . . . .	14
4.2.1 Food Temperature	
4.2.2 Food Storage	
4.3 Gastronorm (GN) Pans . . . . .	14
4.4 Temperature Adjustment . . . . .	15
4.5 Gantry Operation . . . . .	16

## 5.0 Cleaning and Maintenance

5.1 Cleaning . . . . .	17
5.1.1 General Information	
5.1.2 Corrosion Protection	
5.1.3 Surface Finish	
5.1.4 Cleaning and Maintenance Schedule	
5.1.5 Materials Required	
5.1.6 Bain Marie (Daily)	
5.1.7 Hot Cupboard (Daily)	
5.1.8 External Surfaces (Daily)	
5.1.9 Glass (Daily)	
5.2 Troubleshooting . . . . .	19
5.2.1 Troubleshooting Procedures	
5.2.2 Alarm Signals	
5.3 Heat Lamp Bulbs . . . . .	20
5.3.1 Replacement Procedure	
5.4 Disposal . . . . .	20

## 1.1 Your New Culinaire Product

Thank you for choosing this quality Culinaire product.

All Culinaire products are designed and manufactured to meet the needs of food service professionals. By caring for and maintaining this new Culinaire product in accordance with these instructions, will provide many years of reliable service.

Stoddart is a wholly Australian owned company, which manufactures and/or distributes a comprehensive range of food service equipment for kitchens, food preparation and presentation. Stoddart products are manufactured and engineered to provide excellent results whilst offering value-for-money, ease-of-use and reliability.

---

**Carefully read this instruction booklet, as it contains important advice for safe installation, operation and maintenance. Keep this booklet on hand in a safe place for future reference by other operators or users.**

### Disclaimer

The manufacturer/distributor cannot be held responsible or liable for any injuries or damages of any kind that occur to persons, units or others, due to abuse and misuse of this unit in regards to installation, removal, operation, servicing or maintenance, or lack of conformity with the instructions indicated in this documentation.

All units made by the manufacturer/distributor are delivered assembled, where possible, and ready to install. Any installation, removal, servicing, maintenance and access or removal of any parts, panels or safety barriers that is not permitted, does not comply in accordance to this documentation, or not performed by a **TRAINED AND AUTHORISED SPECIALIST** will result in the **IMMEDIATE LOSS OF THE WARRANTY.**

The manufacturer/distributor cannot be held responsible or liable for any unauthorised modifications or repairs. All modifications or repairs must be approved by the manufacturer/distributor in writing before initiating. All modifications or repairs performed to this unit must be performed at all times by a **TRAINED AND AUTHORISED SPECIALIST.**

**Stoddart design, manufacture & distribute Food Service Equipment (appliances) exclusively for the commercial market.  
This appliance is not designed nor intended for household or domestic use and must not be used for this purpose.**

This product is intended for commercial use, and in line with Australian electrical safety standards the following warnings are provided:

- This product is not intended for use by persons (including children) with reduced physical, sensory or mental capabilities, or lack of experience and knowledge, unless they have been given supervision or instruction concerning the use of the product by a person responsible for their safety. Children should be supervised to ensure that they do not play with the product
- If the supply cord is damaged, it must be replaced by the manufacturer, its service agent or similarly qualified persons in order to avoid a hazard



## Warranty & Registration

### 1.2 Australia and New Zealand Warranty

#### 1.2.1 Warranty Period

All Stoddart manufactured and distributed products are covered by Stoddart's standard Australia and New Zealand Product Warranty (minimum 12 month on-site parts and labour, terms and conditions apply). Further to this standard warranty, certain products have access to an extended warranty. Full terms, conditions and exclusions can be found using the below Link/QR code.

#### 1.2.2 Warranty Registration

To register your new product, Follow the below Link/QR code.



Australia  
[CLICK HERE](#)



New Zealand  
[CLICK HERE](#)







### 1.3 General Precautions

When using any electrical unit, safety precautions must always be observed.

Our units have been designed for high performance. Therefore, the unit must be used exclusively for the purpose for which it has been designed.

- All units **MUST** be installed according to the procedures stated in the installation section of this manual
- In the case of new personnel, training is to be provided before operating the equipment
- **DO NOT** use this unit for any other purpose than its intended use
- **DO NOT** store explosive substances such as aerosol cans with a flammable propellant in or near this unit
- Keep fingers out of "pinch point" areas
- Unit is not waterproof **DO NOT** use jet sprays, hoses or pour water over/on the exterior of the unit
- Only use this unit with voltage specified on the rating label
- **DO NOT** remove any cover panels that may be on the unit
- **DO NOT** use sharp objects to activate controls
- If any fault is detected, refer to troubleshooting
- The manufacturer declines any liability for damages to persons and/or things due to an improper/wrong and/or unreasonable use of the machine

**2.1 Important Information**

	<b>IMPORTANT</b>
	<p style="text-align: center;">This unit is supplied for wet operation as standard. For dry operation Contact Stoddart</p>
	<b>WARNING</b>
	<p style="text-align: center;">The surfaces of this unit are <b>HOT</b> when operating</p>
	<b>IMPORTANT</b>
	<p style="text-align: center;">This unit is not designed to cook products, it only maintains them above the regulated 65°C serving temperature.</p>
	<b>WARNING</b>
	<p style="text-align: center;">The water in the unit and the surfaces of this unit are <b>HOT</b> when operating. Take caution and do <b>NOT</b> place any part of the body in the water.</p>
	<b>IMPORTANT</b>
	<ul style="list-style-type: none"> <li>• This unit must be completely emptied, drained, and refilled with fresh water daily.</li> <li>• Failure to follow this procedure may void the warranty.</li> </ul>
	<b>IMPORTANT</b>
	<p style="text-align: center;"><b>Water with a low chloride levels must be used!</b> Water with high chloride levels will cause corrosion to the unit.</p> <p style="text-align: center;">For areas with a high chloride content (i.e. SA, WA or country areas) demineralised water should be used in all cases.</p>
	<b>IMPORTANT</b>
	<p style="text-align: center;">The Bain Marie is designed for wet operation. Running the unit dry may result in greater temperature variation, requiring relocation of the temperature probe by a qualified technician. For assistance, please contact Stoddart.</p>

## 2.2 Product Overview

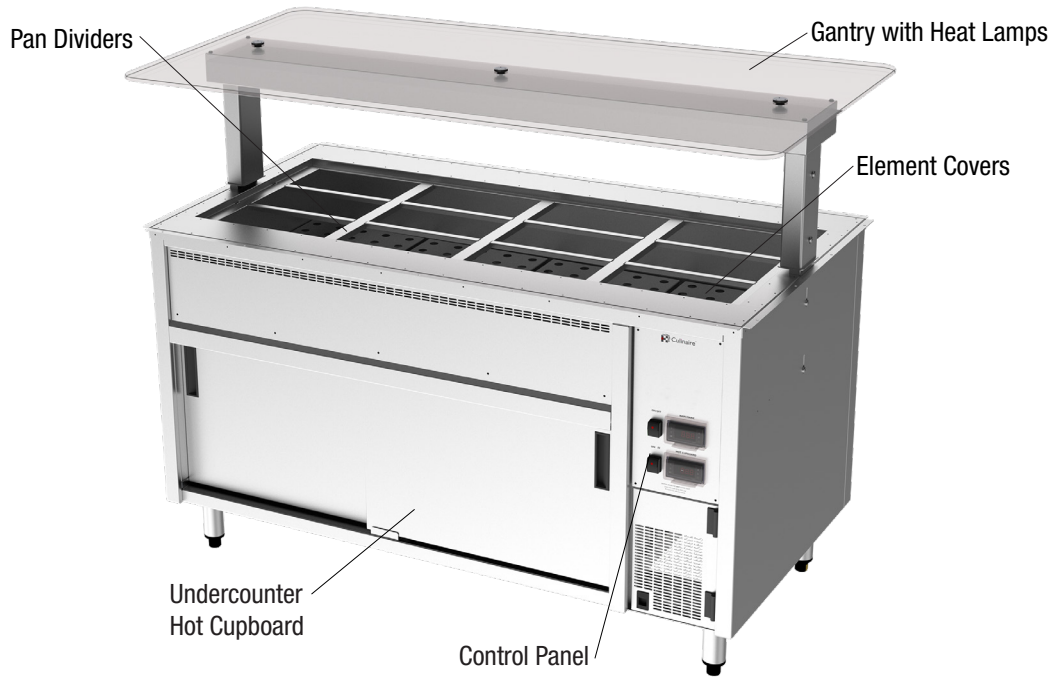

Due to continuous product research and development, the information contained herein is subject to change without notice.

## 2.3 Setting Up

	<b>WARNING</b>
	<b>Improper installation, adjustments, alterations, service or maintenance can cause property damage, injury or death.</b>

### 2.3.1 Handling

- Use suitable means to move the unit;
  - For smaller items use two people
  - For large items a fork lift, pallet trolley or similar (the forks should reach completely beneath the pallet)

### 2.3.2 Unpacking

- Check the unit for damage before and after unpacking. If unit is damaged, contact the distributor and manufacturer
- Should any item have physical damage, report the details to the freight company and to the agent responsible for the dispatch within 48 hours of receipt. No claims will be accepted or processed after this period
- The unit is supplied fully assembled
- Remove all protective plastic film, tapes, ties and packers before installing and operating
- Clean off any remaining residue from the interior/exterior of the unit using a clean cloth dampened with warm soapy water

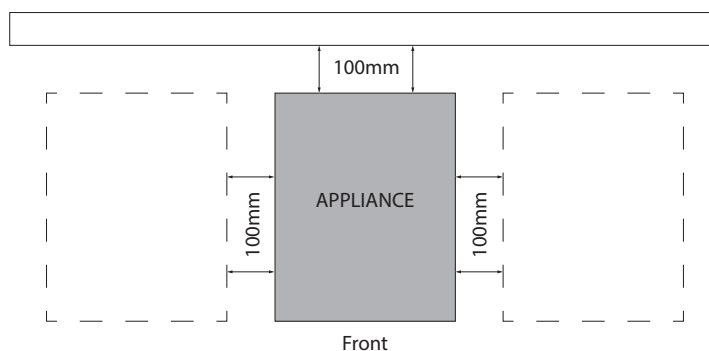

### 2.3.3 Positioning

- Choose an area that is well ventilated and provides access for future maintenance
- Place the unit on a level stable work surface capable of supporting its weight
- Do not position the unit in:
  - Wet areas
  - Near heat and/or steam sources
  - Near flammable substances
- Allow an air gap between the unit and other objects or surfaces. A minimum gap of 100mm from all sides is recommend for normal operational use (if the unit is near any heat sensitive material we suggest you allow additional space)



- Please consult national and local standards to ensure that your unit is positioned in accordance with any existing requirement

## 2.4 Plumbing Connections

	<b>IMPORTANT</b>
	<p>This unit must be installed in accordance with the Plumbing Code of Australia (PCA)</p>
	<b>IMPORTANT</b>
	<p>This unit must be operated using potable water. Use water with low chloride levels only.</p> <p><b>High-chloride water can cause corrosion. If the water contains high chloride levels, a filtration system MUST BE installed. Operating the unit without filtered water may void the warranty.</b></p>

- This unit must be drained to a tundish
- This unit must be connected to a hot or cold water supply (hot produces quicker start up times) with an isolation tap
- The unit is supplied with a G 1/2" BSP Water Connection for filling the well. The water valve MUST be tested for leakages after being installed
- The unit is supplied with a G 1 1/2" BSP drainage connection
- The wastewater connection screws into the drainage connection. The wastewater MUST be tested for leakages after being installed
- The unit MUST be on a level surface for the water to drain properly
- The Bain Marie is fitted with an overflow which maintains the correct water level in the well
- Before use, the water purity needs to be checked; high mineral water can corrode the elements and taint the water/food. If needed, a filtration system should be installed

### 2.4.1 Specification

<b>Water Connection</b>	1/2" BSP
<b>Drainage Connection</b>	1 1/2" BSP
<b>Water Inlet Pressure</b>	100 - 500KPA
	If the incoming water pressure is above the specified maximum (500 kPa), install a pressure limiting valve
<b>Tempered water supply</b>	Max. 65°C



Due to continuous product research and development, the information contained herein is subject to change without notice.

## 2.5 Electrical Connection

	<b>WARNING</b>
	<p>This unit must be installed in accordance with local electrical regulations/requirements.</p> <p>Some procedures in this manual require the power to the equipment to be turned off and isolated. Turn the power OFF at the power point and unplug the power supply lead by the plug body. If the power point is not readily accessible turn the equipment off at the isolation switch or the circuit breaker in the switchboard. Attach a yellow “CAUTION-DO NOT OPERATE” tag. This must be performed where relevant unless the procedures specify otherwise.</p> <p style="text-align: center;"><b>FAILURE TO DO SO MAY RESULT IN ELECTRIC SHOCK.</b></p>

### Single Phase Units:

- Supplied and fitted with an appropriately rated plug and lead, indicated as:
  - 10A plug & lead fitted
  - 15A plug & lead fitted
  - 20A plug & lead fitted
- A terminal block for on-site connection, by a licensed electrician will be supplied inside the unit service compartment, indicated as:
  - 1Ø+N+E

### Three Phase Units:

- Supplied and fitted with an appropriately rated plug and lead, indicated as:
  - 32A plug & lead fitted
- A terminal block for on-site connection, by a licensed electrician will be supplied inside the unit service compartment, indicated as:
  - 3Ø + N + E

### Notes:

- If the supply cord is damaged, it must be replaced by the manufacturer, its service agent or similarly qualified persons in order to avoid a hazard. Please contact Stoddart for parts and we will advise how to do this in order to avoid any electrical hazard
- The power cable should be dry and/or isolated from moisture or water

## 2.6 Shelves

	<b>IMPORTANT</b>
	<p>Do not adjust/move the base shelf clips.</p> <p>No items should be stored on the floor of the unit, preventing air circulation</p>

### 2.6.1 Shelf Adjustment

Note: Do not use pliers when moving shelf clips

- The shelf support pin needs to be facing up
- Squeeze the pin to fit the bottom of the clip in
- The shelf clips clip into the rail
- All four pins for the shelf need to be at the same height for a level shelf
- The outer frame of the shelf fits over the shelf

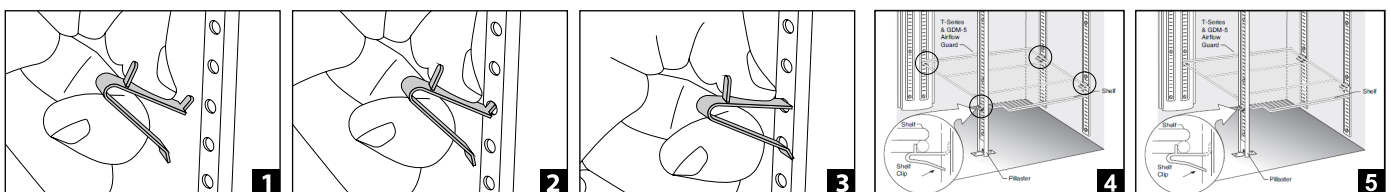

## 2.7 Under Counter Bain Marie

### 2.7.1 Well Opening Sizes

The finished opening sizes in the bench top should be 5mm smaller than the well opening sizes (refer to section 3.0 Specification). For example, the finished opening size in the bench for a 3-module bain marie should be **1052mm x 543mm**. Ensure adequate support is provided to the bain marie to bear the weight of the unit when filled with water. Well sizes may vary slightly due to the manufacturing process. It is recommended to take measurements from the actual unit being fitted. Pan dividers are not included with under-counter units and are sold separately.

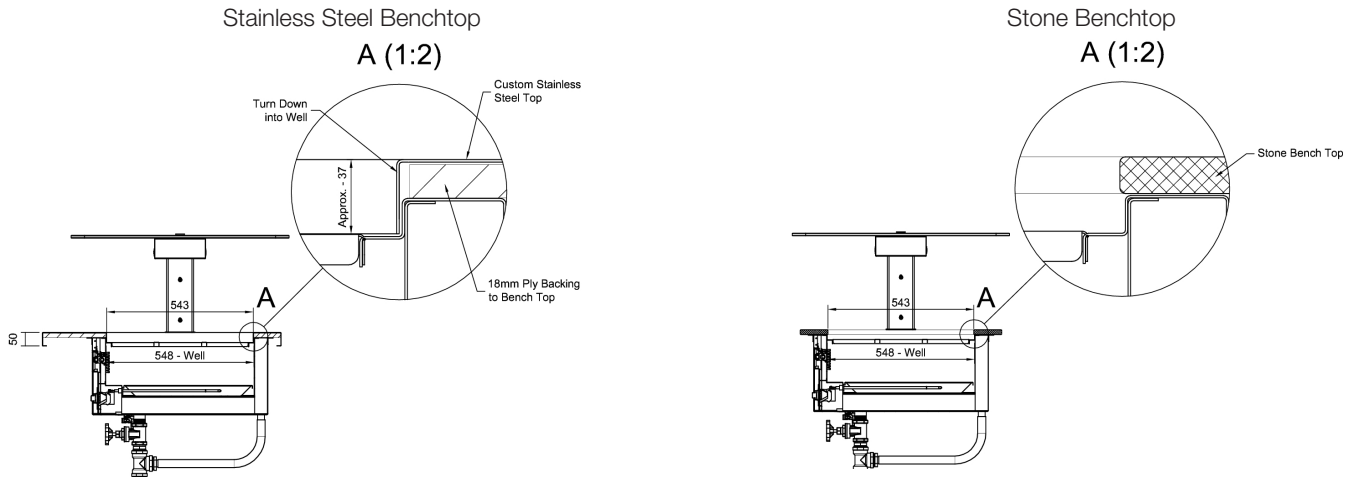

## 2.8 Bain Marie Element Covers & Dividers

### 2.8.1 Bain Marie Element Covers

- Element covers are placed over the top of the elements for protection

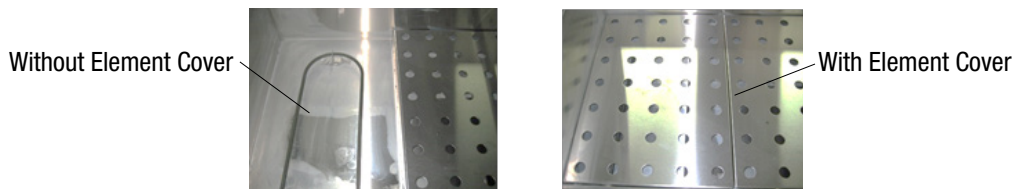

### 2.8.2 Bain Marie Dividers

- Install as shown when 1/1 module dividers are provided
- 1/2 dividers are sold separately

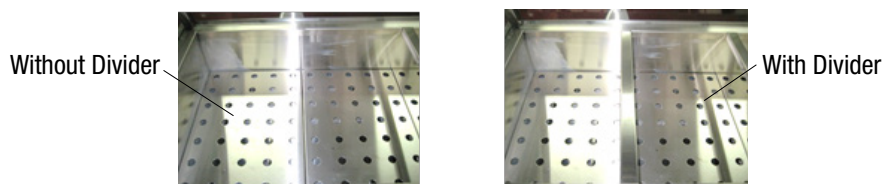



Due to continuous product research and development, the information contained herein is subject to change without notice.

### 3.1 Bain Marie - Undercounter

Model	CH.BMHC.U.GSF.3	CH.BMHC.U.GSF.4	CH.BMHC.U.GSF.5	CH.BMHC.U.GSF.6	CH.BMHC.U.GSF.7	CH.BMHC.U.GSF.8
<b>W x D x H (mm)</b>	1137 x 691 x 661	1477 x 691 x 661	1817 x 691 x 661	2157 x 691 x 661	2497 x 691 x 661	2837 x 691 x 661
<b>Total Connected Load</b>	4.65kW	5.7kW	7.15kW	7.9kW	10.3kW	11.4kW
<b>Electrical Connection</b>	1Ø+N+E 240VAC / 50Hz (Onsite connection)	3Ø+N+E 400VAC / 50Hz (Onsite connection)	3Ø+N+E 400VAC / 50Hz (Onsite connection)	3Ø+N+E 400VAC / 50Hz (Onsite connection)	3Ø+N+E 400VAC / 50Hz (Onsite connection)	3Ø+N+E 400VAC / 50Hz (Onsite connection)
<b>Water Connection</b>	G 1/2" BSP	G 1/2" BSP	G 1/2" BSP	G 1/2" BSP	G 1/2" BSP	G 1/2" BSP
<b>Waste Connection</b>	1 1/4" BSP	1 1/4" BSP	1 1/4" BSP	1 1/4" BSP	1 1/4" BSP	1 1/4" BSP
<b>Well Opening W x D (mm)</b>	1057 x 548	1397 x 548	1737 x 548	2077 x 548	2417 x 548	2757 x 548

4.1 Initial Start-up & Operation

	<b>IMPORTANT</b>
	This unit is not designed to cook products, it only maintains them above the regulated 65°C serving temperature.
	<b>WARNING</b>
	The water in the unit and the surfaces of this unit are HOT when operating. Take caution and do NOT place any part of the body in the water.
	<b>IMPORTANT</b>
	<ul style="list-style-type: none"> <li>• This unit must be completely emptied, drained, and refilled with fresh water daily.</li> <li>• Failure to follow this procedure may void the warranty.</li> </ul>

4.1.1 Control Panel

The Bain Marie and the hot cupboard independently controlled, this allows either section to operate when required

- The Bain Marie can be switched ON or OFF with the BAIN MARIE power switch
- The hot cupboard can be switched ON or OFF with the HOT CUPBOARD power switch

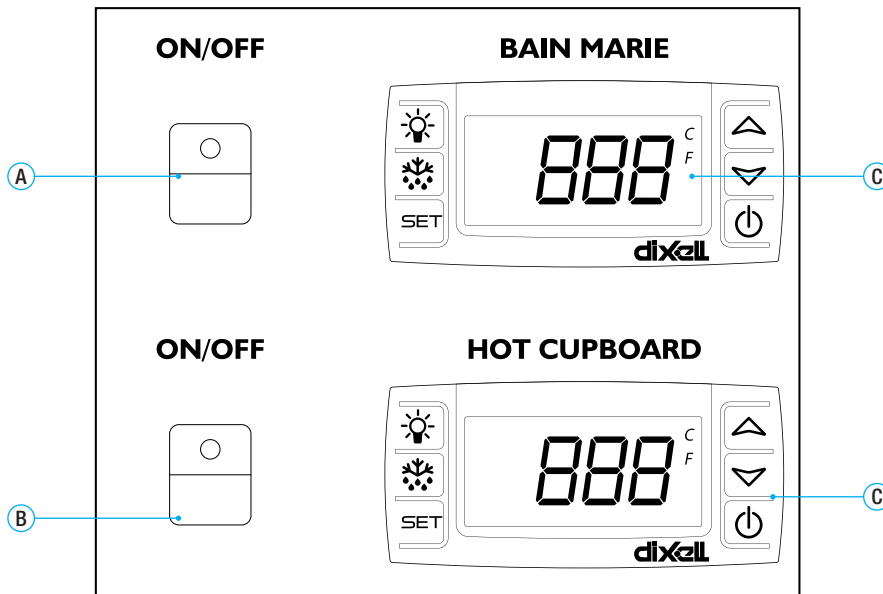

Item	Function	Description
A	Power Switch ON/OFF - Bain Marie	Turns the bain marie and gantry lights ON or OFF
B	Power Switch ON/OFF - Hotcupboard	Turns the hotcupboard ON or OFF
C	Digital Thermostat Controller	The temperature can be set between 65°C and 95°C

Due to continuous product research and development, the information contained herein is subject to change without notice.

#### 4.1.2 Initial Start-up

- Before switching ON the unit - The element covers, dividers and shelves need to be placed in the unit
- Fill unit with water using the ball valve provided or manually fill with a suitable container to bottom of the overflow or approx. Ensure the elements are submerged in water (minimum of 10mm)
- Place all pans and/or lids onto the bain marie
- Turn on lights
- Turn the electronic controller ON. Ensure the well is heating to operating temperature
- Leave the bain marie to operate with water in the well for 3 - 4 hours
- Check the water level of the bain marie hourly
- Allow the unit to cool, drain the well using the ball valve provided either in the service compartment or under the unit. After, clean the whole unit, including the Gastronorm pans

#### 4.1.3 Using as a Wet Unit

- Fill unit with water. Ensure the elements are submerged in water (minimum of 10mm). Hot or cold water can be used. Hot water will save on heating time and power consumption
- Turn the electronic controller ON and set to the required temperature allow approximately 10-15
- Check water levels while the unit is in use, top up the water level as required ensuring elements remain submerged
- This unit **MUST** be completely emptied/drained and re-filled with fresh water daily
- Water **MUST** not be recycled. After being in the unit, all water **MUST** be treated as waste water. Do NOT drink and/or serve to persons

#### 4.1.4 Using as a Dry Unit

The Bain Marie is designed for wet operation. Running the unit dry may result in greater temperature variation, requiring relocation of the temperature probe by a qualified technician. For assistance, please contact Stoddart.

#### 4.1.5 Loading Bain Marie

- Ensure that the Bain Marie is switched ON and has reached operating temperature before placing any food in the unit
- All food **MUST** be pre-heated/cooked above the regulated 65°C serving temperature before placing in the unit
- Only Gastronorm pans are to be placed in the well
- All food products must sit below top edge of the GN pan in order for the food to stay hot
- Food should be left in the unit no longer than 2 hours

#### 4.1.6 Loading Hot Cupboard

	<b>IMPORTANT</b>
	<p><b>Do not adjust/move base shelf clips.</b>  <b>No items should be stored on the floor of the unit, preventing air circulation</b></p>

- Ensure that the unit is switched ON and have reached operating temperature before placing any food in the unit
- All food **MUST** be pre-heated/cooked above the regulated 65°C serving temperature before placing in the unit
- Do not adjust/move base shelf clips
- No items should be stored on the floor of the unit, preventing air circulation

#### 4.1.7 Loading Restrictions

- Ensure the heat vents are NOT covered when serving items and gastronorm pans are in the unit. Airflow restrictions will change the temperature within the cupboard
- Overloading the shelves can bend and damage the shelves and shelf clips

#### 4.1.6 After Service Period

- Drain the well, no water should remain in the bain marie
- Ensure the benches around the well are cleaned and dried
- Remove all items from the hotcupboard

### 4.2 Food Safety

#### 4.2.1 Food Temperature

- All food **MUST** be pre-heated/cooked before placing in the unit. Attempting to cook food with this unit can lead to food poisoning
- The temperature reached on the temperature gauge is the water/air temperature, **NOT** the food temperature
- It is important to regularly monitor the food temperature with a temperature probe to ensure it is above the regulated 65°C serving temperature
- Ensure the benches around the well are cleaned continuously to prevent contaminants entering the pans

**Note:** The thermometer is meant as guide only. It indicates the temperature of the water (when used as a wet unit) or the temperature under the food pans (when used as a dry unit). It does not indicate the temperature of the food. Do not use the top of the unit as a serving area.

#### 4.2.2 Food Storage

- All storage of food should comply with local health standards and regulations
- All pans should be cleaned and placed in night storage. No pans should be left in the unit
- This unit is **NOT** designed to store product after hours. The unit **MUST** be switched OFF
- If the unit is moved for night storage, ensure the castors are locked (mobile units only)

### 4.3 Gastronorm (GN) Pans

- All Gastronorm pans and extra dividers are sold separately
- Each module can hold one 1/1 pan, two 1/2 pans, three 1/3 pans, four 1/4 pans, six 1/6 pans and nine 1/9 pans. Pan depths are 25mm, 65mm, 100mm and 150mm. Contact your distributor about the best possible depth for the product you intent to display
- For 1/6 and 1/9 Gastronorm pans, extra dividers are required

## 4.4 Temperature Adjustment

- The temperature can be set between 65°C and 95°C. How to set the temperature is shown below
- Different modes require different temperatures
- The temperature probe only measures the temperature of the water/air, NOT the food temperature

### DIXEL CONTROL:

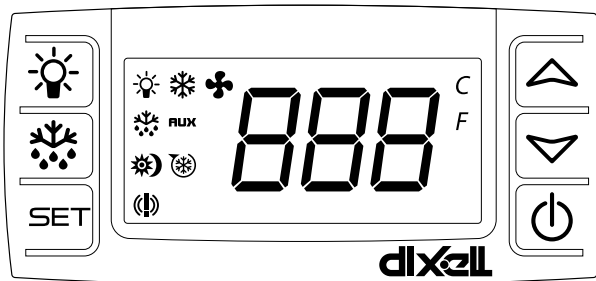

### DISPLAY:

LED	MODE	DESCRIPTION
	On	Compressor enabled
	Flashing	Anti short cycle delay enabled (AC parameter)
	On	Defrost in progress
	Flashing	Dripping in progress
	On	Fans output enabled
	Flashing	Fans delay after defrost
	On	An alarm is occurring
	On	Continuous cycle is running
	On	Energy saving enabled
	On	Measurement unit
	Flashing	Programming mode

### KEY FUNCTIONS:

SET	To display target set point; in programming mode it selects a parameter or confirm an operation.
(DEF)	To start a manual defrost push and hold the defrost button  for 2 seconds.
(UP)	To see the maximum stored temperature; in programming mode it browses the parameter codes or increases the displayed value.
(DOWN)	To see the minimum stored temperature; in programming mode it browses the parameter codes or increases the displayed value.
	To switch the instrument OFF, if onF = OFF.
	Not enabled.

### KEY COMBINATIONS:

+	To lock and unlock the keyboard.
SET +	To enter in programming mode.
SET +	To return to the room temperature display.

### HOW TO SEE THE SET POINT:

1. Push and immediately release the **SET** key, the display will show the set point value
2. Push and immediately release the **SET** key or wait 5 seconds to display the probe value again

### HOW TO CHANGE THE SET POINT:

1. Push the **SET** key for more than 3 seconds to change the set point value
2. The value of the set point will be displayed and the “°C” LED starts blinking
3. To change the set point value push the or arrows within 10 seconds
4. To store the new set point value push the **SET** key again or wait 10 seconds

### HOW TO CHANGE A PARAMETER VALUE:

1. Enter the Programming mode by pressing the **SET** + keys for 3s ( °C LED starts blinking)
2. Select the required parameter. Press the **SET** key to display its value
3. Use or to change the parameter value
4. Press SET to store the new parameter value and move to the following parameter
5. To Exit: Press **SET** + or wait 15 seconds without pressing any keys

**Note:** The set value is stored even when the procedure is exited by waiting the time-out to expire.

**Note:** To enter in programming mode. (Contact the Stoddart Service Department)

### HOW TO LOCK/UNLOCK THE KEYBOARD:

1. To lock the keyboard press and hold the + for 3 seconds. The “OF” message will be displayed
2. To unlock the keyboard press and hold the + for 3 seconds. The “ON” message will be displayed

### 4.5 Gantry Operation

	<b>IMPORTANT</b>
	<p>When the bain marie is being operated as a wet unit with a gantry is fitted, ensure that the heat lamps over the well are always on (if not pre-wired from the factory)</p>

#### **Power**

- Heat Lamps can be switched ON or OFF with the GANTRY button on the unit
- Lamps **MUST** be switched ON when the unit is in operation. Steam from operating as a wet unit and/or steam from foods can pool on the lamps and damage the wiring

#### **Surfaces**

- Nothing should be stored on the top of the gantry
- When operating, the surfaces may be hot. Signage should be displayed for personal and customers to ensure no one will burn themselves

#### **Rear Sliding Doors**

- As glass can be HOT, ensure the rear door slide are OPENED and CLOSED with the glass pulls

**5.1 Cleaning**

	<b>IMPORTANT</b>
	<ul style="list-style-type: none"> <li>• This unit must be completely emptied, drained, and refilled with fresh water daily.</li> <li>• Failure to follow this procedure may void the warranty.</li> </ul>

	<b>IMPORTANT</b>
	<p>Threaded fasteners can loosen in service. Regular inspection and adjustment should be carried out as required</p>

	<b>WARNING</b>
	<p>This unit is <b>NOT</b> waterproof, do <b>NOT</b> hose. <b>DO NOT</b> pour water directly onto the unit. <b>DO NOT</b> immerse in water</p>

	<b>IMPORTANT</b>
	<p>Some commercial stainless steel cleaners leave residue or film on the metal that may entrap fine particles of food, deeming the surface not <b>FOOD SAFE</b></p>

	<b>WARNING</b>
	<p>Wait until the unit has cooled to a safe temperature before undertaking any cleaning or maintenance. Contact with hot surfaces can cause burns and serious injury</p>

**5.1.1 General Information**

- Cleaning is recommended for health and safety purposes and to prolong the life of the unit
- **DO NOT** use abrasive pads or cleaners on the stainless steel or any other metal parts of the unit
- **DO NOT** use industrial chemical cleaners, flammable cleaners, caustic based cleaners or bleaches and bleaching agents, as many will damage the metals and plastics used on this unit
- **DO NOT** remove any screws and/or panels for cleaning (unless directed)
- This unit is **NOT** waterproof, **DO NOT** hose, **DO NOT** pour water directly onto the unit, **DO NOT** immerse in water

**5.1.2 Corrosion Protection**

- Stainless steel exhibits good resistance to corrosion however, if not properly maintained stainless steel can rust and/or corrode
- Any sign of mild rust and/or corrosion should be thoroughly cleaned with warm soapy water and dried as soon as possible
- **NEVER** use abrasive pads or cleaners for cleaning
- All metal surfaces should be checked while cleaning for damage, scuffs or scrapes as these can lead to rust and further damage to the product
- Thoroughly wipe the surfaces dry after cleaning. **DO NOT** let water pool on the unit. Check crevices and folds for pooling
- When using, ensure all liquids and moisture is cleaned up straight away.  
Food liquids such as juices from vegetables and fruits should not be left on any surfaces
- **DO NOT** leave items on the stainless steel such as cutting boards, rubber mats and bottles

**5.1.3 Surface Finish**

- To protect the polished surface of the stainless steel, it should be dried using a clean dry soft cloth. A light oil can be applied to enhance the stainless steel surface, using a clean cloth apply the oil in the same direction as grained polished finish
- Some commercial stainless steel cleaners can leave residue or film on the metal; this may trap fine particles of food on the surface, thus deeming the surfaces not food safe

### 5.1.4 Cleaning and Maintenance Schedule

- Daily cleaning is required for the unit. This will help to maintain and prolong the efficiency of your unit
- The unit should be cleaned at the end of each work day

### 5.1.5 Materials Required

- Non Abrasive Cleaning pad
- Clean Sanitised Cloth
- Warm Soapy Water
- Appropriate PPE (Personal Protective Equipment)

### 5.1.6 Bain Marie (Daily)

1. Isolate from the power supply
2. The unit **MUST** be drained before cleaning
3. Remove all Dividers, Element Covers & Gastronorm Pans
4. Clean the unit with warm (not hot) soapy water and a sponge. Ensure all due care is taken when cleaning the elements, as they can become damaged
5. After cleaning, flush the unit with clean fresh water
6. Thoroughly wipe the unit dry with a soft cloth. Do **NOT** let water pool in the unit, check crevices and folds
7. Re-insert all Dividers, Element Covers & Gastronorm Pans

### 5.1.7 Hot Cupboard (Daily)

1. Isolate from the power supply
2. Remove Shelves from the Hot Cupboard. Shelves can be cleaned in a kitchen sink with warm soapy water. Thoroughly wipe dry with a soft cloth after cleaning, do **NOT** allow to air dry
3. Wipe the hot cupboard clean using a cloth dampened (not wet) with clean warm water until all soil has been removed
4. Using a clean sanitised cloth, thoroughly wipe the stainless steel and metal parts dry. Do **NOT** let water pool on the unit. Check crevices and folds

### 5.1.8 External Surfaces (Daily)

1. Isolate from the power supply
2. Wearing Personal Protective Equipment (PPE), apply Stainless Cleaner with the Cleaner pad to the external surfaces
3. Scrub any baked on soil with the cleaner pad in the same direction as grained polish
4. Wipe clean using a cloth dampened with clean warm water until all Stainless Cleaner and soil has been removed
5. Using a clean sanitised cloth, thoroughly wipe the stainless steel and metal parts dry. Do **NOT** let water pool on the unit. Check crevices and folds

### 5.1.9 Glass (Daily)

1. Clean the glass with a glass cleaner or warm (not hot) soapy water, and a sponge
2. Wiping dry with a squeegee is best

## 5.2 Troubleshooting

- If any faults/issues occur with the unit, follow the below troubleshooting procedures
- If the troubleshooting procedures do not correct the problem, contact the Stoddart Service Department

	<b>WARNING</b>
	<b>Technician tasks are only to be completed by qualified service people. Check faults before calling service technician.</b>

### 5.2.1 Troubleshooting Procedures

Problem	Possible Causes	Remedy
<b>Unit does not operate / start</b>	The mains isolating switch on the wall, circuit breaker or fuses are OFF at the power board	Turn isolating switch, circuit breaker or fuses ON
	The power switch of the unit is OFF	Turn the power switch ON
	Electrical wiring damaged	Technician task. Contact the Stoddart Service Department
<b>Unit does not reach temperature</b>	Temperature not set to the right setting	Check setting and adjust the temperature
	Exhaust fan above the unit	Move unit / exhaust fan
	Cold items in units	Remove items and heat properly
	Cold water in the unit	Close the water valve / Wait 30 minutes
	Temperature gauge broken	Technician task. Contact the Stoddart Service Department
	Thermostat or Temperature probe broken	Technician task. Contact the Stoddart Service Department
	Mineral deposits on element	Technician task. Contact the Stoddart Service Department
<b>Food not at desired temperature</b>	Element blown	Technician task. Contact the Stoddart Service Department
	Thermostat set incorrectly	Adjust thermostat
<b>Water pooling around the unit</b>	Unit is not reaching required temperature after thermostat adjustment	Technician task. Contact the Stoddart Service Department
	Drain not in the tundish / Bucket overflowing	Place drain in the tundish / Clear and replace bucket
	Unit not level	Place unit on a level surface
<b>Corrosion</b>	Connection seals / drain valve broken	Replace seals / drain valve
	Poor water quality	Test water quality
<b>Scale build up</b>	Not being drained, cleaned and emptied daily	Follow cleaning schedule of user manual
	Scale build up on elements and unit	Descale unit

### 5.2.2 Alarm Signals

Display	Cause	
P1	Room probe failure	Compressor output according to "Cv" e "Cn"
P2	Evaporator probe failure	Defrost end is timed
HA	Maximum temp. alarm	Outputs unchanged
HA	Maximum temp. alarm	Outputs unchanged
LA	Minimum temp. alarm	Outputs unchanged
HA2	Condenser high temperature	It depends on the "Ac2" parameter
LA2	Condenser low temperature	It depends on the "bLL" parameter
dA	Door Open	Compressor and fans restarts
EA	External alarm	Outputs unchanged
CA	Serious external alarm	All outputs OFF
CA	Pressure switch alarm (i1F=PAL)	All outputs OFF

### 5.3 Heat Lamp Bulbs

#### 5.3.1 Replacement Procedure

- Bulbs should be allowed to cool for 10 - 15 minutes before removing
  - All heat lamp fittings are spring loaded for easy replacement
  - Heat lamp bulbs should only be replaced with gloves or a soft cloth. No skin should touch the new bulb. If skin touches the new bulb, wipe the bulb with a soft cloth and rubbing alcohol to remove all possible oils
1. Isolate from the power supply
  2. Squeeze the ends of the lamp shield bars to remove
  3. Holding the old bulb with a soft cloth or glove, press into one of the sockets, rotate out and remove
  4. Holding the new bulb with a soft cloth or glove, press into one of the sockets, rotate in and slowly release the bulb into the other socket, ensuring that the bulb does NOT become broken
  5. Re-install the lamp shield bars

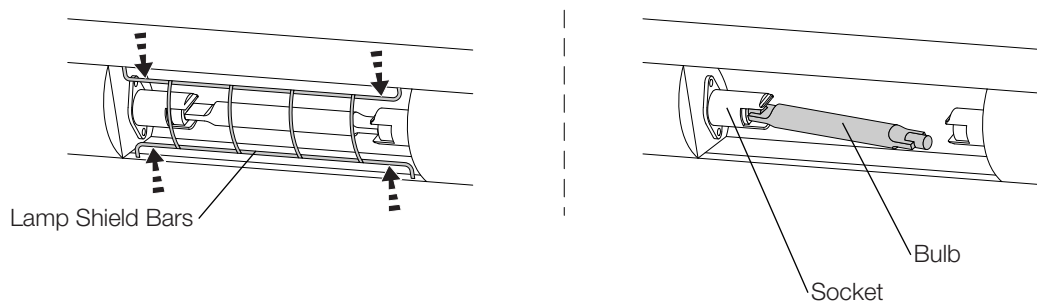

SCAN FOR  
REPLACEMENT BULBS  
(CMEL.1665)



### 5.4 Disposal

If the appliance is no longer of use, please dispose in an environmentally correct way.

The distributor / retailer can contact their local metal recycling centre to collect the remaining cabinet, shelves, etc.

There may be special requirements or conditions. Information on the disposal of refrigeration appliances can be obtained from:

- Your supplier
- Government authorities (The local council, Ministry of the Environment, etc.)



Discarded electric appliances are recyclable and should not be discarded in the domestic waste! Please actively support us in conserving resources and protecting the environment by returning this appliance to the collection centres (if available).



Dispose of packaging in accordance to applicable legal regulations.





## Australia

Australian Business Number: 16009690251

### Service / Spare Parts

<https://customerservice.stoddart.com.au>

### Sales

Tel: 1300 79 1954

Email: [sales@stoddart.com.au](mailto:sales@stoddart.com.au)

Web: [www.stoddart.com.au](http://www.stoddart.com.au)



Customer  
Service Portal

---

## New Zealand

New Zealand Business Number: 6837694

### Service / Spare Parts

<https://customerservice.stoddart.com.au>

### Sales

Tel: 0800 79 1954

Email: [sales@stoddart.co.nz](mailto:sales@stoddart.co.nz)

Web: [www.stoddart.co.nz](http://www.stoddart.co.nz)



Customer  
Service Portal