

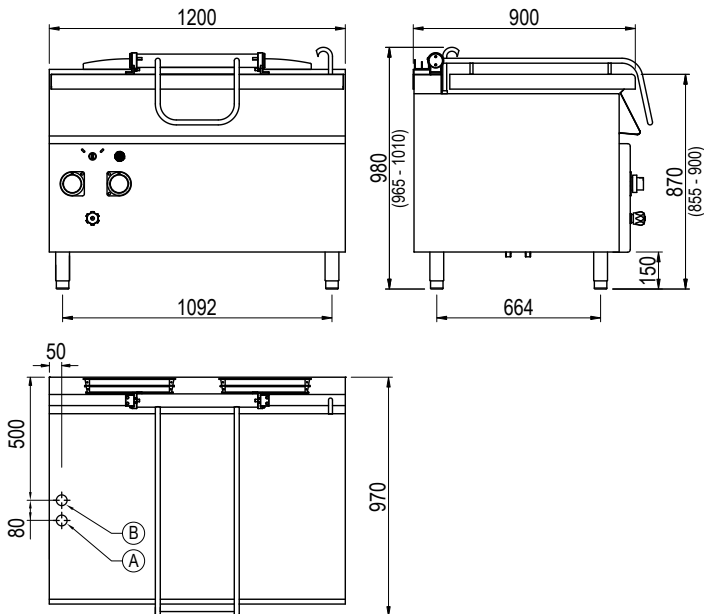

Product Information:

- Class leading, European style, professional quality and reliability since 1963
- 900 series, high performance electric bratt pan with 120 litre capacity and electric tilting pan (20.5kW)
- Duplex 2304 10mm thick stainless steel base for superior heat transfer, strength and corrosion resistance
- Heating elements with Hi-limit temperature protection
- Temperature regulation via thermostat (50°C - 300°C)
- Heating shut off via microswitch when the pan is tilted
- Indicator lights to monitor the correct operation of the appliance
- Water fill via integrated valve and spout
- Double skinned counterbalanced lid with rear condensation channel
- Robust 304 grade stainless steel construction with rounded corners for improved cleaning
- Height adjustable stainless steel feet for a 900mm working height
- 24-month warranty

General Drawing:



Specifications:

Model	BE96XAT
W x D x H (mm)	1200 x 970 x 980
Weight	200kg
Capacity	120L
Cooking Area	1126 x 595 x 130
Packed Dimensions (mm)	1250 x 1025 x 1200
Packed Weight (mm)	217kg
Electrical Connection	3Ø + N + E 415VAC / 50Hz / 20.5kW

Legend:

- A** Electrical Connection
- B** Water Connection 1/2" BSP

Due to continuous product research and development, the information contained herein is subject to change without notice.

Revision: 02 - 08/04/2026 - A

