



Round - Wall Mounted

Model: SPPL.DF.R.WM.xxx.yy

SPPL = Stoddart Plumbing Product
 DF = Drinking Fountain
 R = Round
 WM = Wall Mounted
 xxx = 300 = 300mm splashback (optional)
 yy = BF - Bottle Filler (bottle filler supplied separately)
 eg: for specification and ordering quote
 Code: SPPL.DF.R.WM.300.BF

Features and Benefits

- Approved design drinking fountain for government schools
- Economical design makes this the affordable solution for schools and institutions
- Lead free compliant
- Easy mount bracket system for quick installation
- No sharp edges ensuring safe use and cleaning
- WELS rated supplied bubbler for easy and efficient water access
- When connecting to a waste, a trap must be used for connection to the outlet
- Plumbing components used with this product meet or exceed the performance requirements of WMTS-105

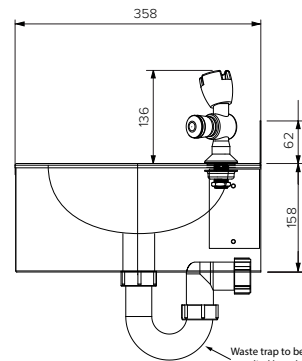
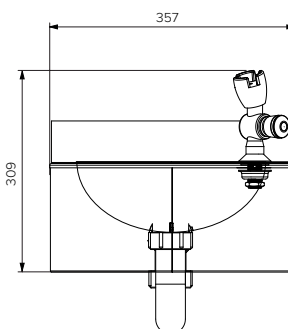
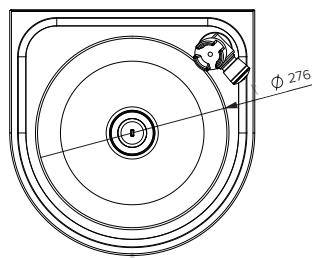
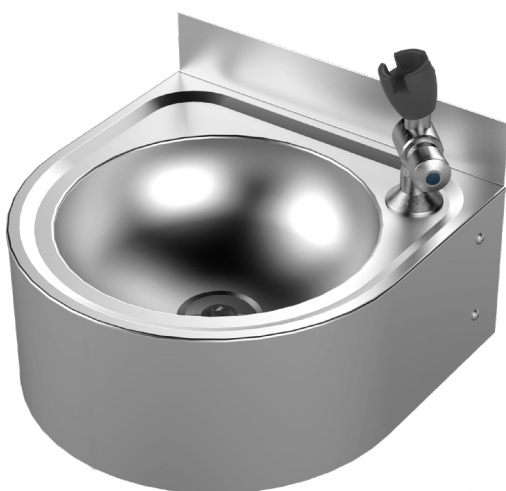

Specifications:

Construction: 1.2 304 grade stainless steel construction, no.4 satin finish.
 Water Connection: Single 15mm (1/2" BSP)
 Waste Connection: 40mm waste connection
 Unit Fixing: The unit is supplied with a stainless steel wall mounting bracket with 8mm diameter fixing holes.

Sold Separately - Tapware Options:



CMPL.1226

Tapware components supplied for this appliance are Watermarked and WELS rated

Model No.	L x D x H (mm)
SPPL.DF.R.WM	357 x 358 x 309
SPPL.DF.R.WM.BF	357 x 358 x 309
SPPL.DF.R.WM.300	360 x 358 x 458
SPPL.DF.R.WM.300.BF	360 x 358 x 458



Due to continuous product research and development, the information contained herein is subject to change without notice.

Revision: A - 1/05/2026 - 05

www.stoddart.com.au

www.stoddart.co.nz