



Square - Freestanding

Model: SPPL.DF.S.FS.xx

SPPL = Stoddart Plumbing Product
 DF = Drinking Fountain
 S = Square
 FS = Freestanding
 BF = Bottle Filler (bottle filler supplied separately)
 eg: for specification and ordering quote
 Code: SPPL.DF.S.FS

Features and Benefits

- Ideal for public access areas in shopping malls, schools and office foyers
- Back access panel for installation and maintenance
- Lead free compliant
- WELS certified and watermarked bubbler included
- When connecting to a waste, a trap must be used for connection to the outlet
- Plumbing components used with this product meet or exceed the performance requirements of WMTS-105

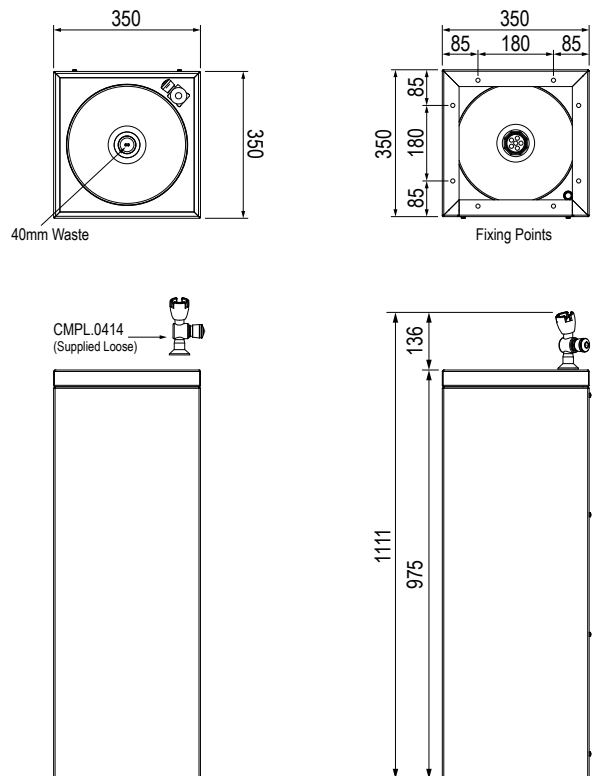
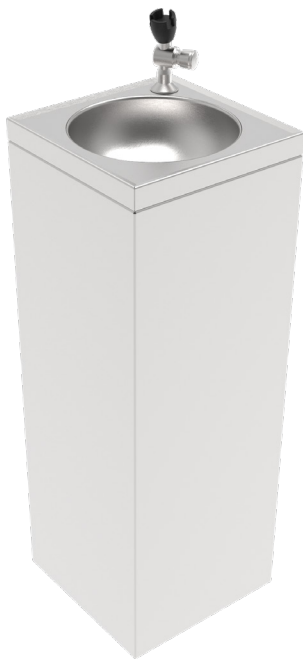

Specifications:

Construction: 1:5mm 304 grade stainless steel construction, no.4 satin finish. Unit is supplied with button and bubbler.

Water Connection: Single 15mm (1/2" BSP)

Waste Connection: 40mm waste connection

Unit Fixing: The unit is supplied with floor mounting points

Model No.	L x D x H (mm)
SPPL.DF.S.FS	350 x 350 x 1110
SPPL.DF.S.FS.BF	350 x 350 x 1110

Sold Separately - Tapware Options:



CMPL.1226

Tapware components supplied for this appliance are Watermarked and WELS rated



Due to continuous product research and development, the information contained herein is subject to change without notice.

Revision: A - 1/05/2026 - 05

www.stoddart.com.au

www.stoddart.co.nz