

KMEST.11.0606

Dynamic Compact Combi Oven
Electric, 6 x 1/1 GN on 6 x 1/1 GN

Product Information

- Compact unit at only 519mm wide (30% less space required than traditional ovens)
 - Highly efficient instant steam injection oven
 - Controlled humidity in the cooking chamber
 - Innovative touch screen interface
 - One Touch function for easy, icon controlled cooking
 - Over 120 pre-set cooking programs, 1,000+ additional programs - 9 phase memory
 - Automatic, adaptive cooking, rack control, regeneration, sous vide and smoking programs
 - Easy Service function and Recipe tuner as standard
 - 3-speed inverter controlled fan for increased precision, control and reliability
 - LED lighting for superior cavity illumination
 - USB connection and core probe
 - Oven cleaning system with liquid, via intergrated dispenser
 - Left hand hinge door option available
 - All Mini Touch ovens are supplied with either the Standard or Reverse Osmosis Filtration system
- **24-month warranty (Terms and conditions apply)**



Specification Stacked

Standard Filter	KMEST.11.0606.SF
Reverse Osmosis	KMEST.11.0606.RO
W x D x H (mm)	531 x 917 x 1734*
* Dimensions do not include water filtration system	
Weight	209kg
Total Connected Load	13.8kW
Cold Water Connection	3/4 BSP 300-350 kpa Min 10°C - Max 30°C
Water Quality Requirements	Hardness: 60-100ppm TDS: <100mg/L Cl Chloride: <32mg/L

Specification Ovens

	KM061WT (Top Oven)	KM061WT (Bottom Oven)
Model	KM061WT (Top Oven)	KM061WT (Bottom Oven)
Capacity	6 x 1/1 GN Pans	6 x 1/1 GN Pans
Total Connected Load	6.9kW / 15A Circuit*	6.9kW / 15A Circuit*
Electrical Connection	3Ø+N+E 415VAC / 50Hz L1=10.4A / L2=9.2A / L3=9.2A	3Ø+N+ E 415VAC / 50Hz L1=10.4A / L2=9.2A / L3=9.2A
- Convertable to	1Ø+N+E 240VAC / 50Hz	1Ø+N+E 240VAC / 50Hz

*Circuit required to be determined at installation by a qualified electrician.

Legend

- A** Electrical Connection
- B** Steam Generation Water Inlet 3/4" BSP
- C** Wash System Water Inlet 3/4" BSP
- D** Drain Connection 40mm
- E** Humidity Vent
- F** Detergent & Rinse Aid Inlet

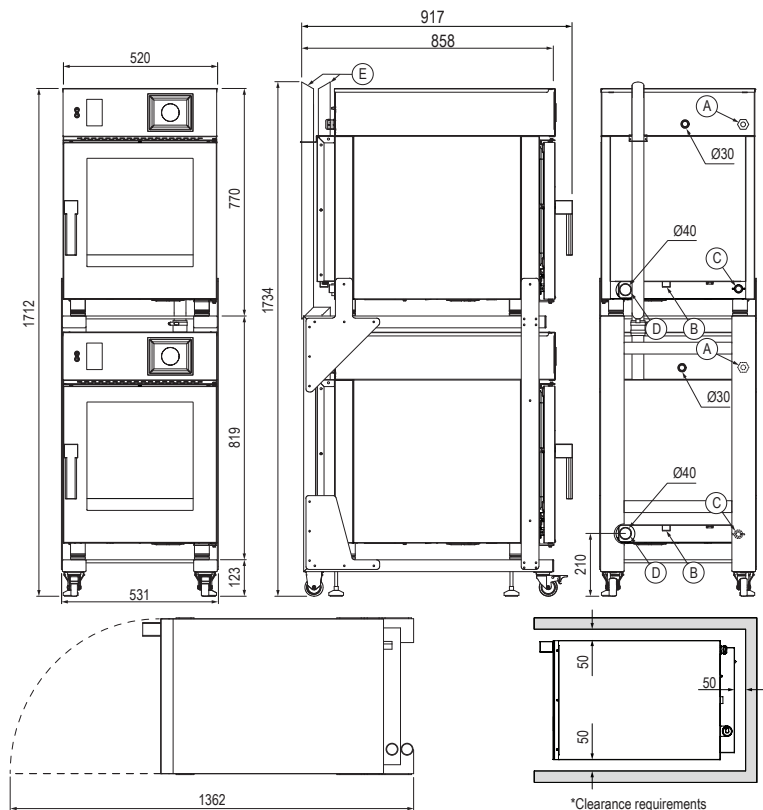

Heat Source: 500mm clearance from an external heat source is required in order to protect the oven control components. For clearances under 500mm, it is mandatory for Stoddart heat shields to be fitted while still maintaining a minimum clearance of 50mm to allow access to the unit. Failure to adhere to minimum clearances may void the oven warranty or add service costs due to lack of access.

Non-Heat Source: 50mm clearance from a non-heat source to allow access to the unit.

Revision: B - 02/04/2025 - 04

www.stoddart.com.au
www.stoddart.co.nz



STODDART®

Due to continuous product research and development, the information contained herein is subject to change without notice.