

Product Information

- High performance hood-type dishwasher
- **Electronic Smart Interface** - with LED display and multicoloured start button
- **PRS System:** break tank, 316 atmospheric boiler, rinse booster pump
- **HD System:** for maximum uninterrupted performance
- Four wash cycles 90/120/180 seconds, and 9 minute deep clean
- Green standby function that reduces energy consumption when idle
- Low water consumption of 2.5 litres per cycle, minimising water, energy and detergent use
- Pressed wash tank with rounded corners, for increased hygiene
- Stainless steel wash and rinse arms
- Robust upper tank scrap filters in stainless steel
- Manual lift with fully enclosed rear, 3 spring support
- Automatic drain pump with self-cleaning function
- Vertical self-draining wash pump
- Built in thermostat, ensures correct rinse temperatures
- Built in detergent and rinse-aid injection
- **24-months parts and labour warranty**



Included Accessories

- 1 x flat cup basket 500 x 500mm
- 2 x peg plate basket 500 x 500mm
- 2 x cutlery insert's
- 1 x water inlet hose, length 1.5m
- 1 x drain hose, length 2.0m
- Fitted with 150mm adjustable legs

Optional Accessories

- Twin hood system
- Remote interface
- Inlet and outlet benches
- Additional baskets

Specifications

Model	AH800ESI.PRS
W x D x H (mm)	657 x 793 x 2016
Note: Dimensions do not include handle. Hood open	
Weight	126kg
Packed Dimensions (mm)	770 x 930 x 1720
Packed Weight	145kg
Total Connected Load	9.55kW / 415VAC, 25A circuit L1 = 12A / L 2 = 9A / L3 = 20A
- Convertible to: (Low Power Option)	6.75kW / 415VAC, 15A circuit L1 = 12A / L 2 = 9A / L3 = 11A
Note: Unit can be converted to low power option on site by a qualified electrician. This may affect the output of the unit.	
Electrical Connection	3Ø+N+E 415VAC / 50Hz (Lead fitted, on-site connection)
Water Quantity Per Cycle	2.5 Litres
Water Connection	1.5m Hose / 3/4" BSP
Water Inlet Pressure	100 - 500KPA
Tempered water supply	10°C - 60°C
Discharge Water Temp.	Max 82°C
Waste Connection	2m Hose / ø20.5mm

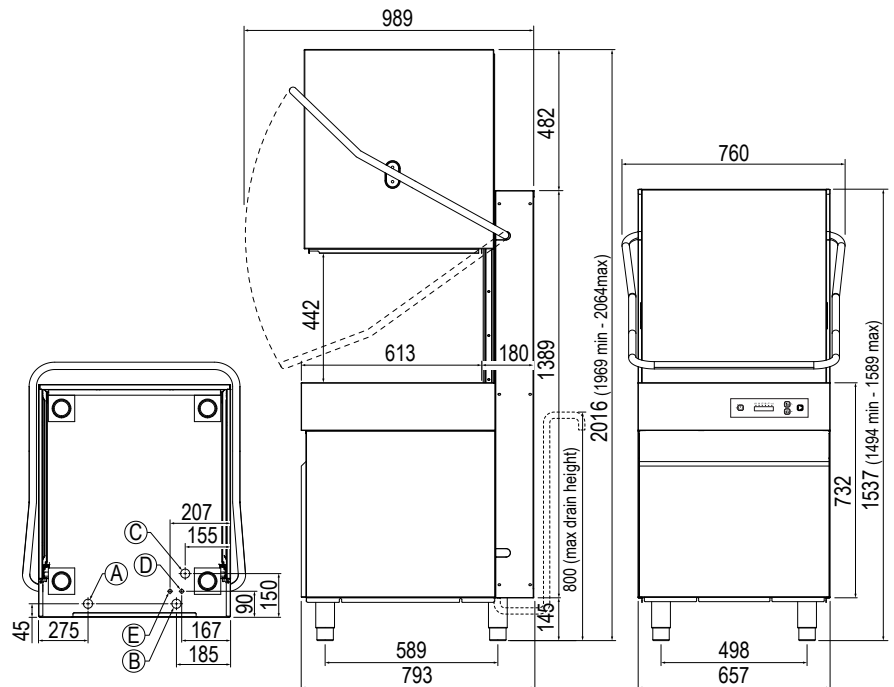

Legend

A Electrical Connection	D Detergent Line
B Water Connection	E Rinse-Aid Line
C Drain Connection	