



# NordicTrack<sup>®</sup>

## COMMERCIAL X11i

nordictrack.com

Model No. NTL22019.2

Serial No. \_\_\_\_\_

Write the serial number in the space above for reference.

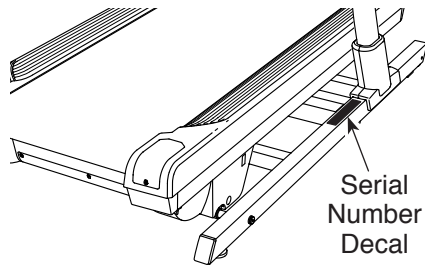

### ACTIVATE YOUR WARRANTY

To register your product and activate your warranty today, go to [my.nordictrack.com](http://my.nordictrack.com)

### CUSTOMER CARE

For service at any time, go to [support.nordictrack.com](http://support.nordictrack.com).

Or call 1-800-TO-BE-FIT  
(1-800-862-3348)

Mon.–Fri. 6 a.m.–6 p.m. MT  
Sat. 8 a.m.–12 p.m. MT

Please do not contact the store.

### ⚠ CAUTION

Read all precautions and instructions in this manual before using this equipment. Save this manual for future reference.

## USER'S MANUAL



# TABLE OF CONTENTS

WARNING DECAL PLACEMENT .....	2
IMPORTANT PRECAUTIONS .....	3
BEFORE YOU BEGIN .....	7
PART IDENTIFICATION CHART .....	8
ASSEMBLY .....	9
THE CHEST HEART RATE MONITOR .....	14
HOW TO USE THE INCLINE TRAINER .....	15
HOW TO MOVE THE INCLINE TRAINER .....	27
MAINTENANCE AND TROUBLESHOOTING .....	28
EXERCISE GUIDELINES .....	31
PART LIST .....	33
EXPLODED DRAWING .....	35
ORDERING REPLACEMENT PARTS .....	Back Cover
LIMITED WARRANTY .....	Back Cover

## WARNING DECAL PLACEMENT

This drawing shows the locations of the warning decals. **If a decal is missing or illegible, call the telephone number on the front cover of this manual and request a free replacement decal. Apply the decal in the location shown.** Note: The decals may not be shown at actual size.

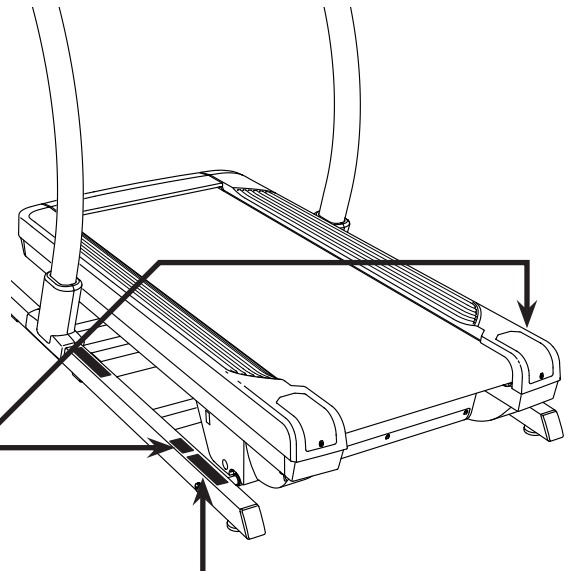

**CAUTION**

KEEP HANDS AND FEET AWAY FROM THIS AREA WHILE THE TREADMILL IS IN OPERATION.

**WARNING:** Protect yourself and others from risk of serious injury. Read the user's manual or obtain proper instruction before use and:

- Stand only on side rails when starting or stopping treadmill.
- Change speed in small increments.
- Hold handrails to prevent falling, and always wear the safety clip while operating treadmill.
- Stop if you feel faint, dizzy, or short of breath.
- Never allow children on or around treadmill.
- Remove key when not in use.
- Keep clothing, fingers, and hair away from moving belt.
- Never try to adjust or fix the belt while it is moving.
- Always wear athletic shoes while operating treadmill.

NORDICTRACK and IFIT are registered trademarks of ICON Health & Fitness, Inc. Google Maps is a trademark of Google LLC. The Bluetooth® word mark and logos are registered trademarks of Bluetooth SIG, Inc. and are used under license. Wi-Fi is a registered trademark of Wi-Fi Alliance. WPA and WPA2 are trademarks of Wi-Fi Alliance.

# IMPORTANT PRECAUTIONS

**⚠️ WARNING:** To reduce the risk of burns, fire, electric shock, or injury to persons, read all important precautions and instructions in this manual and all warnings on your incline trainer before using your incline trainer. ICON assumes no responsibility for personal injury or property damage sustained by or through the use of this product.

1. It is the responsibility of the owner to ensure that all users of this incline trainer are adequately informed of all warnings and precautions.
2. Before beginning any exercise program, consult your physician. This is especially important for persons over age 35 or persons with pre-existing health problems.
3. The incline trainer is not intended for use by persons with reduced physical, sensory, or mental capabilities or lack of experience and knowledge, unless they have been given supervision or instruction concerning use of the incline trainer by someone responsible for their safety.
4. Use the incline trainer only as described in this manual.
5. The incline trainer is intended for home use only. Do not use the incline trainer in any commercial, rental, or institutional setting.
6. Keep the incline trainer indoors, away from moisture and dust. Do not put the incline trainer in a garage or covered patio, or near water.
7. Place the incline trainer on a level surface, with at least 8 ft. (2.4 m) of clearance behind it and 2 ft. (0.6 m) on each side. Do not place the incline trainer on any surface that blocks air openings. To protect the floor or carpet from damage, place a mat under the incline trainer.
8. Do not operate the incline trainer where aerosol products are used or where oxygen is being administered.
9. Keep children under age 16 and pets away from the incline trainer at all times.
10. The incline trainer should be used only by persons weighing 300 lbs. (136 kg) or less.
11. Never allow more than one person on the incline trainer at a time.
12. Wear appropriate exercise clothes while using the incline trainer. Do not wear loose clothes that could become caught in the incline trainer. Athletic support clothes are recommended for both men and women. *Always wear athletic shoes. Never use the incline trainer with bare feet, wearing only stockings, or in sandals.*
13. Plug the power cord into a surge suppressor (not included), and plug the surge suppressor into an appropriate outlet (see page 15). To avoid overloading the circuit, do not plug other electrical devices, except for low-power devices such as cell phone chargers, into the surge suppressor or into an outlet on the same circuit.
14. Use only a surge suppressor that meets all of the specifications described on page 15. To purchase a surge suppressor, see your local NORDICTRACK dealer, call the telephone number on the front cover of this manual, or see your local electronics store.
15. Failure to use a properly functioning surge suppressor could result in damage to the control system of the incline trainer. If the control system is damaged, the walking belt may slow, accelerate, or stop unexpectedly, which may result in a fall and serious injury.
16. Keep the power cord and the surge suppressor away from heated surfaces.
17. Do not operate the incline trainer if the power cord or plug is damaged, or if the incline trainer is not working properly. (See MAINTENANCE AND TROUBLESHOOTING on page 28 if the incline trainer is not working properly.)

18. Read, understand, and test the emergency stop procedure before using the incline trainer. (See HOW TO TURN ON THE POWER on page 17.) Always wear the clip while using the incline trainer.
19. Always stand on the foot rails when starting or stopping the walking belt. Always hold the handrails while using the incline trainer.
20. When a person is walking on the incline trainer, the noise level of the incline trainer will increase.
21. Keep fingers, hair, and clothing away from the moving walking belt.
22. The incline trainer is capable of high speeds. Adjust the speed in small increments to avoid sudden jumps in speed.
23. The heart rate monitor is not a medical device. Various factors, including the user's movement, may affect the accuracy of heart rate readings. The heart rate monitor is intended only as an exercise aid in determining heart rate trends in general.
24. Never leave the incline trainer unattended while it is running. Always remove the key, press the power switch into the off position (see the drawing on page 7 for the location of the power switch), and unplug the power cord when the incline trainer is not in use.
25. Do not attempt to move the incline trainer until it is properly assembled. (See ASSEMBLY on page 9, and HOW TO MOVE THE INCLINE TRAINER on page 27.) You must be able to safely lift 45 lbs. (20 kg) to raise, lower, or move the incline trainer.
26. Never insert any object into any opening on the incline trainer.
27. Inspect and properly tighten all parts each time the incline trainer is used.
28. **DANGER:** Always unplug the power cord immediately after use, before cleaning the incline trainer, and before performing the maintenance and adjustment procedures described in this manual. Never remove the motor hood unless instructed to do so by an authorized service representative. Servicing other than the procedures in this manual should be performed by an authorized service representative only.
29. Over exercising may result in serious injury or death. If you feel faint, if you become short of breath, or if you experience pain while exercising, stop immediately and cool down.

**SAVE THESE INSTRUCTIONS**

# MAKE YOUR FITNESS GOALS A **REALITY**

**iFIT**®

Congratulations on the purchase of your new iFit® compatible fitness equipment. You're just one click away from making your fitness goals a reality.

**GO TO IFIT.COM TO GET STARTED**

## **DO MORE THAN JUST WORK OUT**

iFit® is the most powerful training tool available to help you accomplish all of your fitness goals. From weight loss and performance to personalized training programs, iFit® is the key to getting more out of everything you do. Some features require paid subscription.



### **LOSE WEIGHT**

Stay on track and motivated with progressive weight loss programs with our trainers, including Jillian Michaels.



### **COMPETE WITH OTHERS**

Push yourself to new limits with real-time virtual races.



### **PERSONALIZED EVENT TRAINING**

5k, 10k, half or full marathon training will help you prepare for your event.



### **GO MOBILE**

Track your workout anywhere you go with iFit® mobile apps.



### **MAP YOUR ROUTE**

With Google Maps™, your fitness equipment will simulate the earth's terrain while displaying Street View during your workout.



### **SHARE YOUR PROGRESS**

Inspire others, motivate yourself and share routes, workouts and more.

GO TO

**IFIT.COM**

OR CALL

**877-236-1009**

# PROTECT

YOUR FITNESS EQUIPMENT  
WITH AN EXTENDED SERVICE PLAN

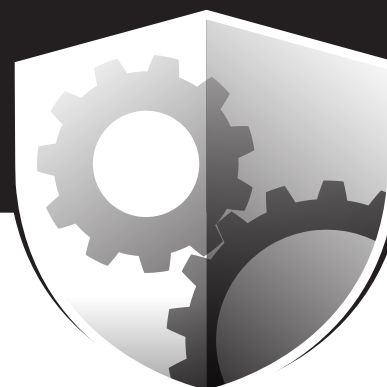

Your new fitness equipment is not an ordinary purchase; it is an investment in your health and well being for years to come.

As the leading provider of manufacturer's extended service plans, ICON strives to protect your equipment and your future.

Please review the following service plans and find one that best fits your needs.

## PREVENTIVE MAINTENANCE SERVICE PLANS

Equipment Price	3-Year Plan	5-Year Plan
\$0.00 to \$1000.00	\$199.99	\$289.99
\$1001.00 to \$1500.00	\$259.99	\$379.99
\$1501.00 to \$2500.00	\$339.99	\$489.99
(Bikes/Systems Only) \$0.00 to \$2500.00	\$139.99	NA

Features:

- Includes an annual preventive maintenance and performance check at your convenience
- Unlimited in-home repairs; no shipping required
- Covers parts and labor on all manufacturer's defects, as well as wear and tear on parts
- Up to 5 years of coverage available

## STANDARD SERVICE PLANS

Equipment Price	1-Year Plan	2-Year Plan	3-Year Plan
\$0.00 to \$300.00	\$29.99	\$39.99	\$59.99
\$301.00 to \$1000.00	\$89.99	\$119.99	\$149.99
\$1001.00 to \$2000.00	\$109.99	\$139.99	\$179.99
\$2001.00 to \$3000.00	\$179.99	\$209.99	\$239.99

Features:

- Unlimited in-home repairs; no shipping required
- Covers parts and labor on all manufacturer's defects, as well as wear and tear on parts
- Up to 3 years of coverage available

To protect your fitness equipment today, please  
call Customer Care at **1-800-677-3838.**  
Or, visit us online at **www.utserv.com.**



# BEFORE YOU BEGIN

Thank you for selecting the revolutionary NORDICTRACK® COMMERCIAL X111 Incline Trainer. The COMMERCIAL X111 Incline Trainer offers a selection of features designed to make your workouts at home more effective and enjoyable.

**For your benefit, read this manual carefully before using the incline trainer.** If you have questions after

reading this manual, please see the front cover of this manual. To help us assist you, note the product model number and serial number before contacting us. The model number and the location of the serial number decal are shown on the front cover of this manual.

Before reading further, please familiarize yourself with the parts that are labeled in the drawing below.

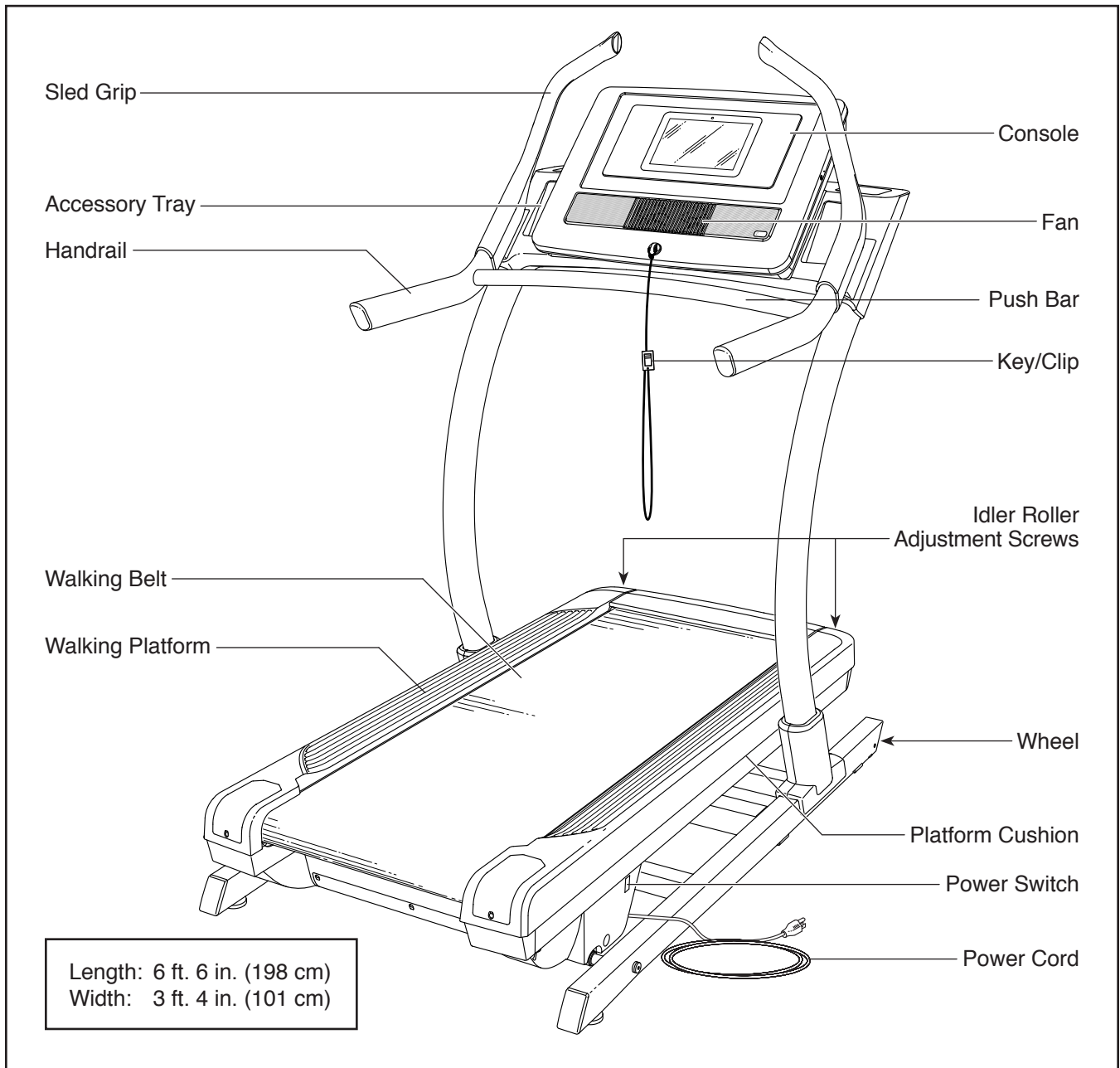

# PART IDENTIFICATION CHART

Use the drawings below to identify small parts used for assembly. The number in parentheses below each drawing is the key number of the part, from the PART LIST near the end of this manual. The number following the key number is the quantity used for assembly. **Note: If a part is not in the hardware kit, check to see whether it is preattached. Extra parts may be included.**

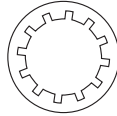

3/8" Star  
Washer (3)-12

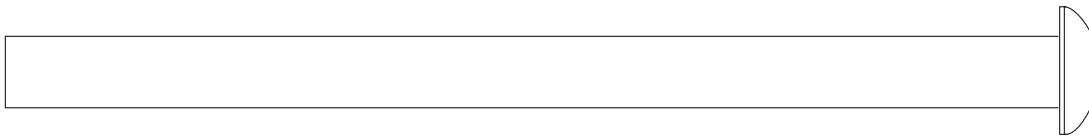

3/8" x 5 1/2" Screw (1)-4

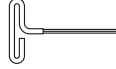

# ASSEMBLY

- Assembly requires two persons.
- Place all parts in a cleared area and remove the packing materials. Do not dispose of the packing materials until you finish all assembly steps.
- After shipping, there may be an oily substance on the exterior of the incline trainer. This is normal. If there is an oily substance on the incline trainer, wipe it off with a soft cloth and a mild, non-abrasive cleaner.
- To identify small parts, see page 8.
- Assembly requires the following tools:  
the included hex keys 
- To avoid damaging parts, do not use power tools.

1. **Go to [my.nordictrack.com](http://my.nordictrack.com) on your computer and register your product.**

- documents your ownership
- activates your warranty
- ensures priority customer support if assistance is ever needed

Note: If you do not have internet access, call Customer Care (see the front cover of this manual) and register your product.

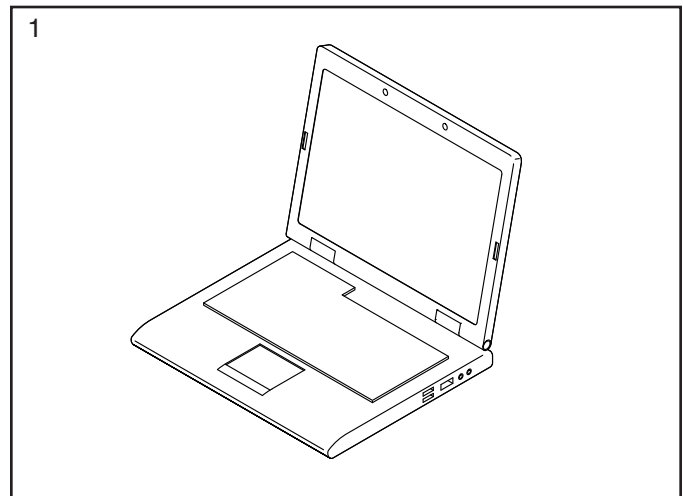

2. **Make sure that the power cord is unplugged.**

Remove the four 3/8" x 3 1/4" Screws (18) from the Base (74) (only one side is shown). **Save the Screws.**

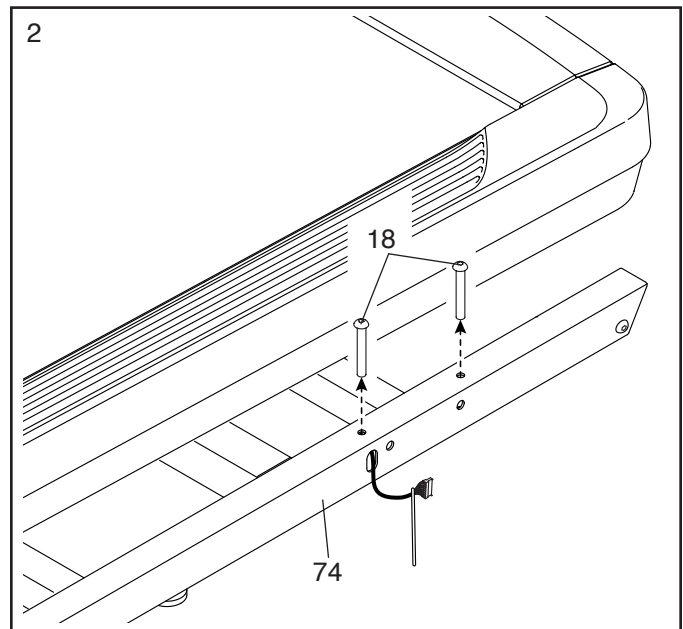

3. Remove the four 3/8" x 2 3/4" Screws (22) from the Uprights (83). **Save the Screws.**

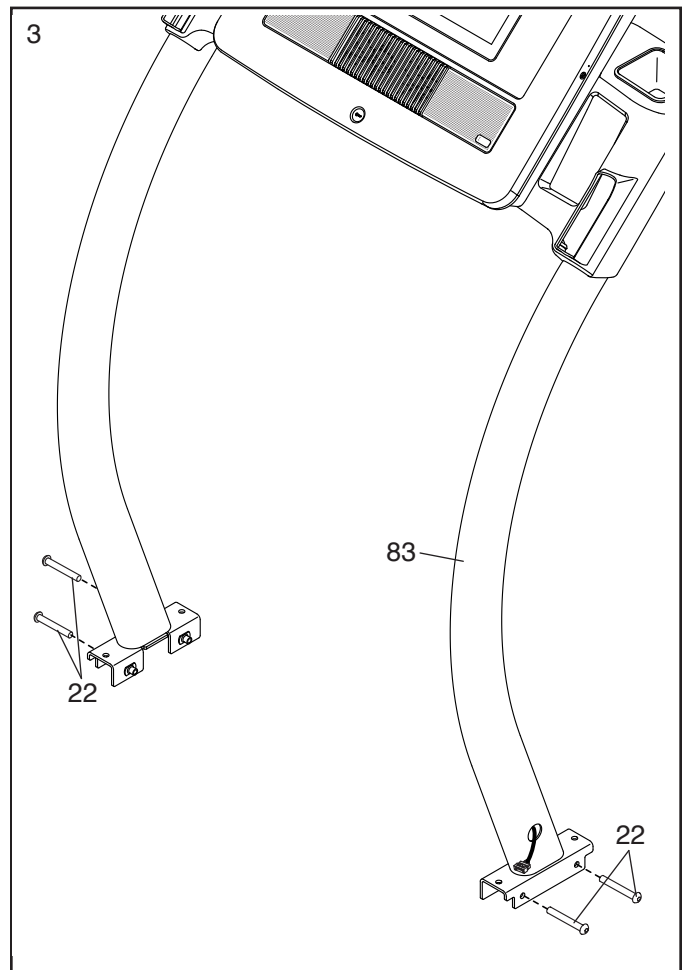

4. Set the Uprights (83) on the Base (74). **Make sure that the hole with the Upright Wire (75) is on the right side.**

Attach the right Upright (83) with two of the 3/8" x 3 1/4" Screws (18) and two of the 3/8" x 2 3/4" Screws (22) that you just removed and four 3/8" Star Washers (3); **do not fully tighten the Screws yet. Make sure that the Base Wire (52) is not pinched.**

**Attach the left Upright (not shown) as described above.** Note: There is not a wire on the left side.

**Then, fully tighten the 3/8" x 3 1/4" Screws (18) and the 3/8" x 2 3/4" Screws (22).**

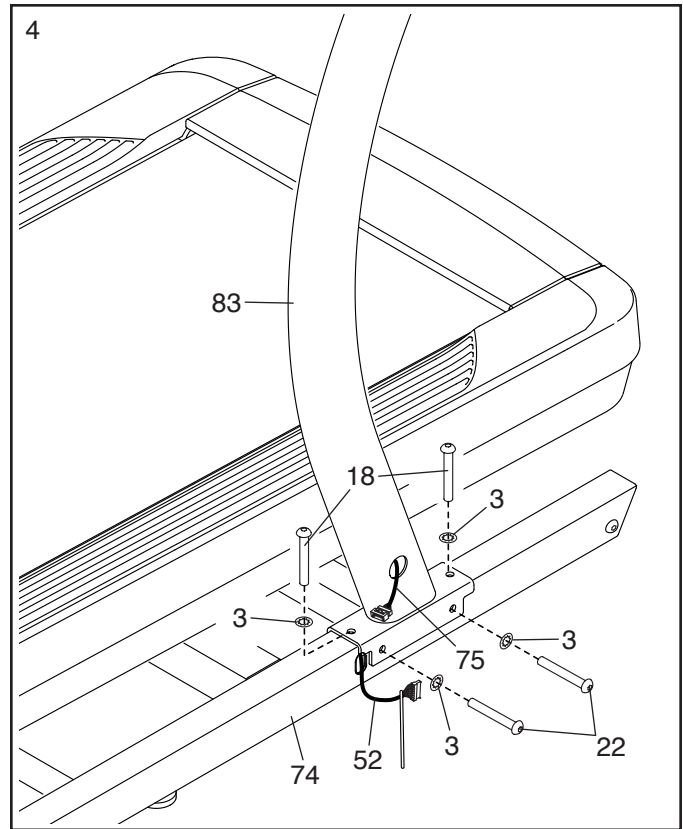

5. **See the inset drawing.** Connect the Base Wire (52) to the Upright Wire (75). **The connectors should slide together easily and snap into place.** If they do not, turn one connector and try again. **IF YOU DO NOT CONNECT THE CONNECTORS PROPERLY, THE CONSOLE MAY BECOME DAMAGED WHEN YOU TURN ON THE POWER.**

Then, remove the tie (A) from the Base Wire (52), and insert the connectors into the hole (B) in the right Upright (83).

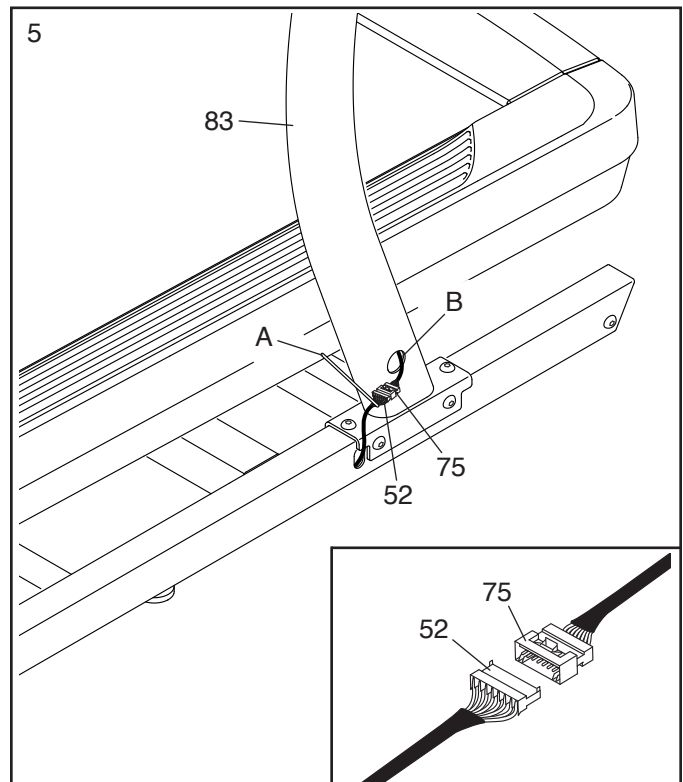

6. Remove the 5/16" x 1" Screws (87) and the 5/16" Star Washers (65) from the brackets (C) on the right and left handrail assemblies (D, E).

With the help of a second person, position the right and left handrail assemblies (D, E) upside down as shown. Attach the Crossbar (85) to the handrail assemblies with the 5/16" x 1" Screws (87) and the 5/16" Star Washers (65); **do not fully tighten the Screws yet.**

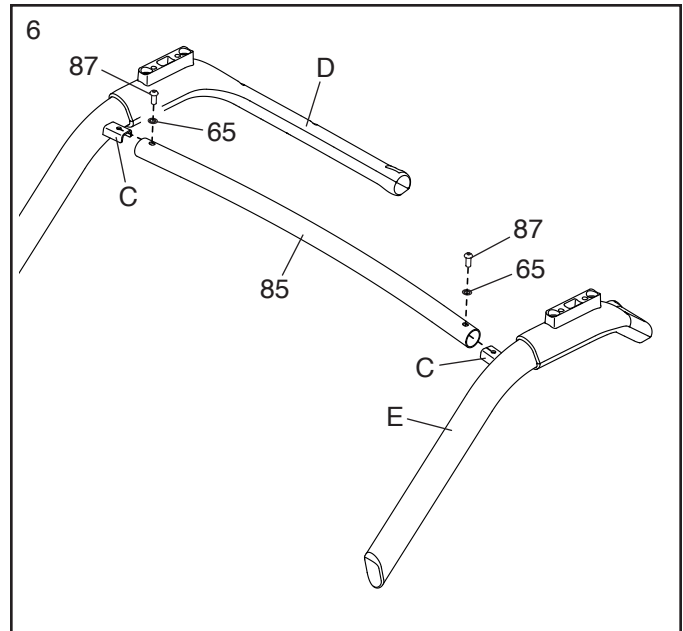

7. With the help of a second person, set the handrail assembly (D) on the console assembly (F).

Attach the handrail assembly (D) with four 3/8" x 5 1/2" Screws (1) and four 3/8" Star Washers (3) (only one side is shown); **start all four Screws, and then tighten them.**

Then, firmly tighten the 5/16" x 1" Screw (87) located under each side of the Crossbar (85).

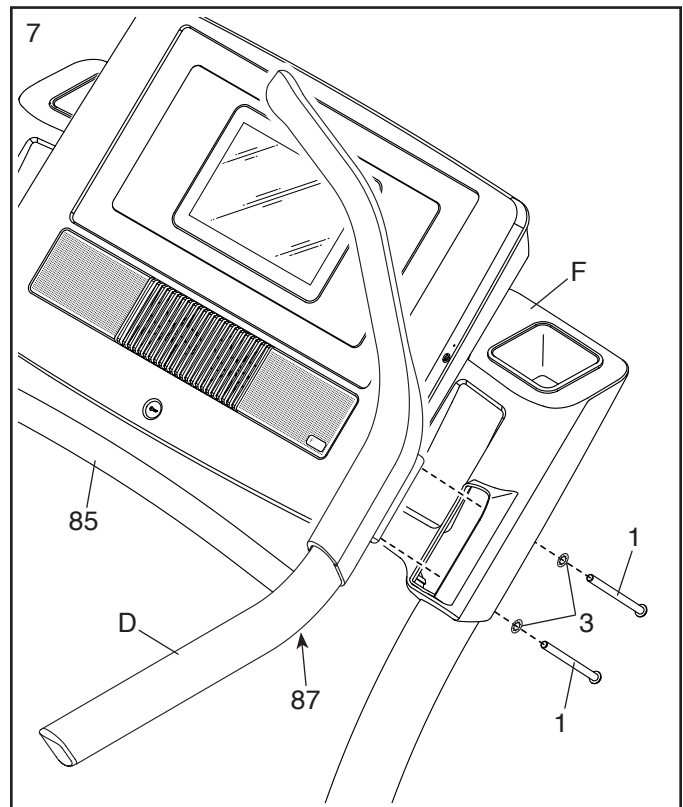

8. Slide the Right Inside Upright Cover (70) against the lower end of the right Upright (83). Then, press the Right Outside Upright Cover (71) against the Right Inside Upright Cover until it snaps into place. **Make sure that the wires (G) are not pinched.**

**Attach the Left Inside Upright Cover (not shown) and the Left Outside Upright Cover (not shown) as described above.** Note: There is not a wire on the left side.

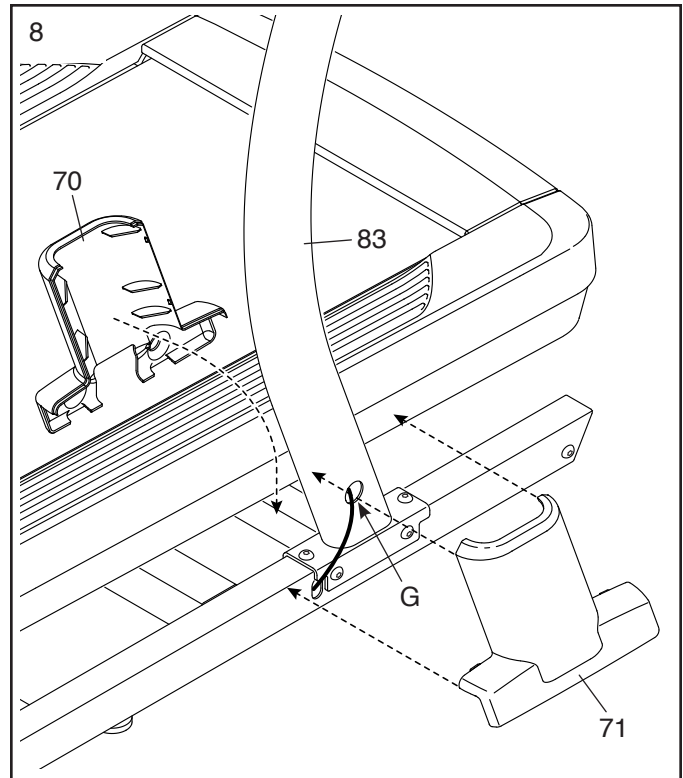

9. If necessary, move the incline trainer to the desired location (see HOW TO MOVE THE INCLINE TRAINER on page 27).

After the incline trainer is placed in the location where it will be used, make sure that the incline trainer rests firmly on the floor. If the incline trainer rocks even slightly, turn a Leveling Foot (77) as needed until the rocking motion is eliminated.

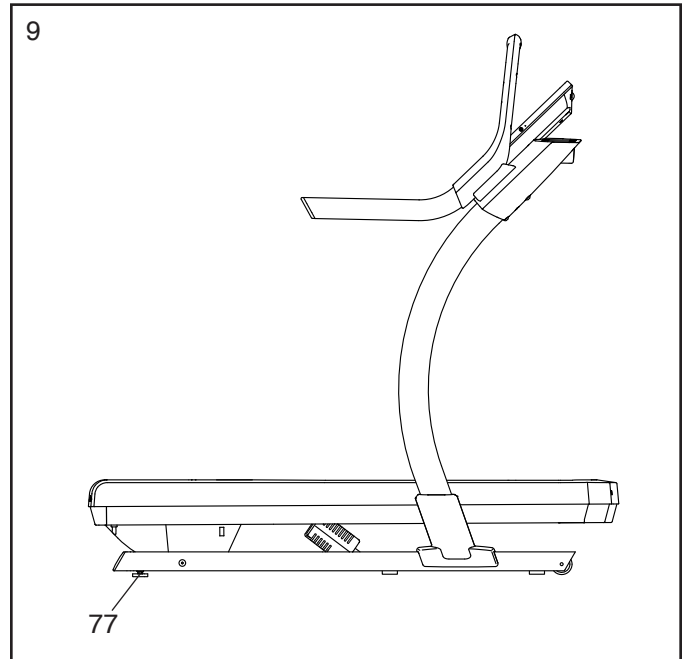

10. **Make sure that all parts are properly tightened before you use the incline trainer.** Keep the included hex keys in a secure place. One of the hex keys is used to adjust the walking belt (see page 29). To protect the floor or carpet from damage, place a mat under the incline trainer. To avoid damage to the console, keep the incline trainer out of direct sunlight.

# THE CHEST HEART RATE MONITOR

## HOW TO PUT ON THE HEART RATE MONITOR

If the heart rate monitor looks like the one shown in drawing 1, press the transmitter (A) onto the snap fasteners on the chest strap (B). If the heart rate monitor looks like the one shown in drawing 2, insert the tab (C) on one end of the chest strap (D) into one end of the transmitter (E). Then, press the end of the transmitter under the buckle (F) on the chest strap; the tab should be flush with the transmitter.

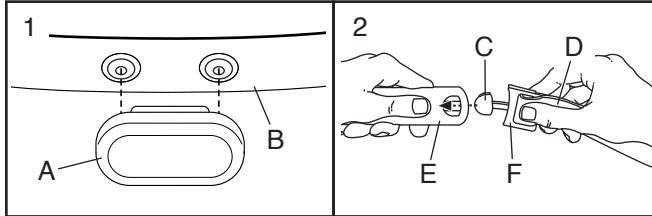

Next, wrap the heart rate monitor around your chest in the location shown; the heart rate monitor must be under your clothes, tight against your skin. Make sure that the logo is right-side-up. Then, attach the other end of the chest strap. Adjust the length of the chest strap, if necessary.

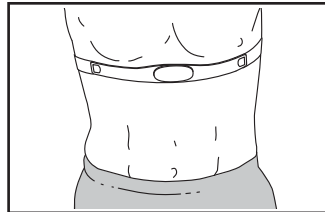

Next, pull the transmitter and the chest strap away from your body a few inches and locate the two electrode areas (G). Using saliva or contact lens solution, wet the electrode areas. Then, return the transmitter and the chest strap to a position against your chest.

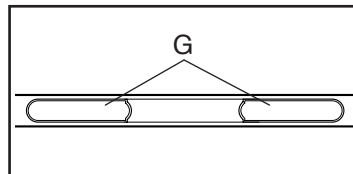

## CARE AND MAINTENANCE

- Thoroughly dry the electrode areas with a soft towel after each use. Moisture may keep the heart rate monitor activated, shortening the life of the battery.
- Store the heart rate monitor in a warm, dry place. Do not store the heart rate monitor in a plastic bag or other container that may trap moisture.
- Do not expose the heart rate monitor to direct sunlight for extended periods of time, and do not expose it to temperatures above 122°F (50°C) or below 14°F (-10°C).
- Do not excessively bend or stretch the heart rate monitor when using or storing it.
- To clean the transmitter, use a damp cloth and a small amount of mild soap. Then, wipe the transmitter with a damp cloth and thoroughly dry it with a soft towel. Never use alcohol, abrasives, or chemicals to clean the transmitter. Hand wash and air dry the chest strap.

## TROUBLESHOOTING

- If the heart rate monitor does not function when positioned as described at the left, move it slightly lower or higher on your chest.
- If heart rate readings are not displayed until you begin perspiring, re-wet the electrode areas.
- For the console to display heart rate readings, you must be within arm's length of the console.
- If there is a battery cover on the back of the transmitter, replace the battery with a new battery of the same type.
- The heart rate monitor is designed to work with people who have normal heart rhythms. Heart rate reading problems may be caused by medical conditions such as premature ventricular contractions (pvc's), tachycardia bursts, and arrhythmia.
- The operation of the heart rate monitor can be affected by magnetic interference from high power lines or other sources. If you suspect that magnetic interference is causing a problem, try relocating the fitness equipment.

# HOW TO USE THE INCLINE TRAINER

## HOW TO CONNECT THE POWER CORD

### Use a Surge Suppressor

Your incline trainer, like other electronic equipment, can be damaged by sudden voltage changes in your home's power. Voltage surges, spikes, and noise interference can result from weather conditions or from other appliances being turned on or off. **To decrease the risk of damaging the incline trainer, always use a surge suppressor (A) with the incline trainer. To purchase a surge suppressor, see precaution 14 on page 3.**

Use only a surge suppressor (A) that is UL 1449 listed as a transient voltage surge suppressor (TVSS). The surge suppressor must have a UL suppressed voltage rating of 400 volts or less and a minimum surge dissipation of 450 joules. The surge suppressor must also be electrically rated for 120 volts AC and 15 amps. There must be a monitoring light on the surge suppressor to indicate whether it is functioning properly. **Failure to use a properly functioning surge suppressor could result in damage to the control system of the incline trainer and serious injury to users.**

### Plug in the Power Cord

**The incline trainer must be grounded.** If it should malfunction or break down, grounding provides a path of least resistance for electric current to reduce the risk of electric shock. The incline trainer power cord (B) has a plug with a grounding pin (C) (see drawing 1 on this page).

**⚠ DANGER:** Improper connection of the power cord increases the risk of electric shock. Do not modify the plug—if it will not fit an outlet, have a proper outlet installed by a qualified electrician. If you are unsure whether the incline trainer is properly grounded, contact a qualified electrician.

Plug the power cord (B) into a surge suppressor (A), and plug the surge suppressor into an appropriate outlet (D) that is properly installed and grounded in accordance with all local codes and ordinances.

The outlet must be on a nominal 120-volt circuit capable of carrying 15 or more amps. To avoid overloading the circuit, do not plug other electrical devices, except for low-power devices such as cell phone chargers, into the surge suppressor or into an outlet on the same circuit. **IMPORTANT: If the incline trainer is connected to an AFCI-equipped outlet and your circuit breaker trips repeatedly when the incline trainer is used, see the front cover of this manual to purchase an arc filter.**

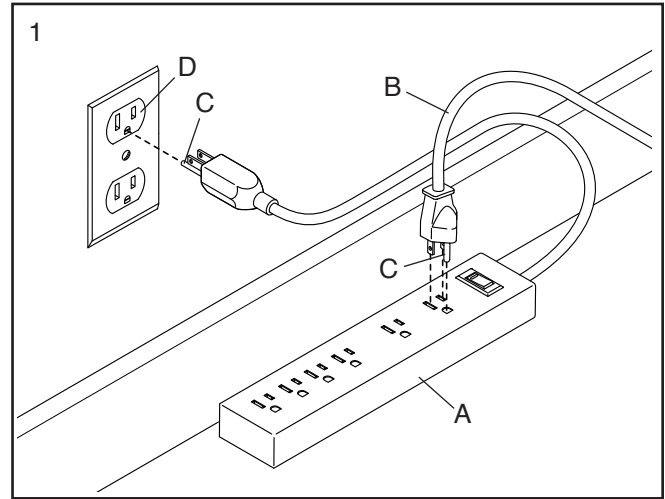

A temporary adapter (E) may be used to connect the surge suppressor (A) to a 2-pole receptacle (F) if a properly grounded outlet is not available.

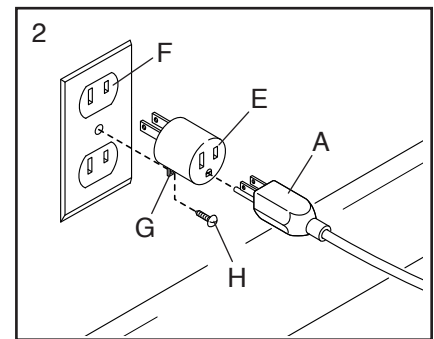

The lug (G) or wire extending from the adapter must be connected with a metal screw (H) to a permanent ground such as a properly grounded outlet box cover. **Some 2-pole receptacle outlet box covers are not grounded. Before using an adapter, contact a qualified electrician to determine whether the outlet box cover is grounded. The temporary adapter should be used only until a properly grounded outlet can be installed by a qualified electrician.**

## CONSOLE DIAGRAM

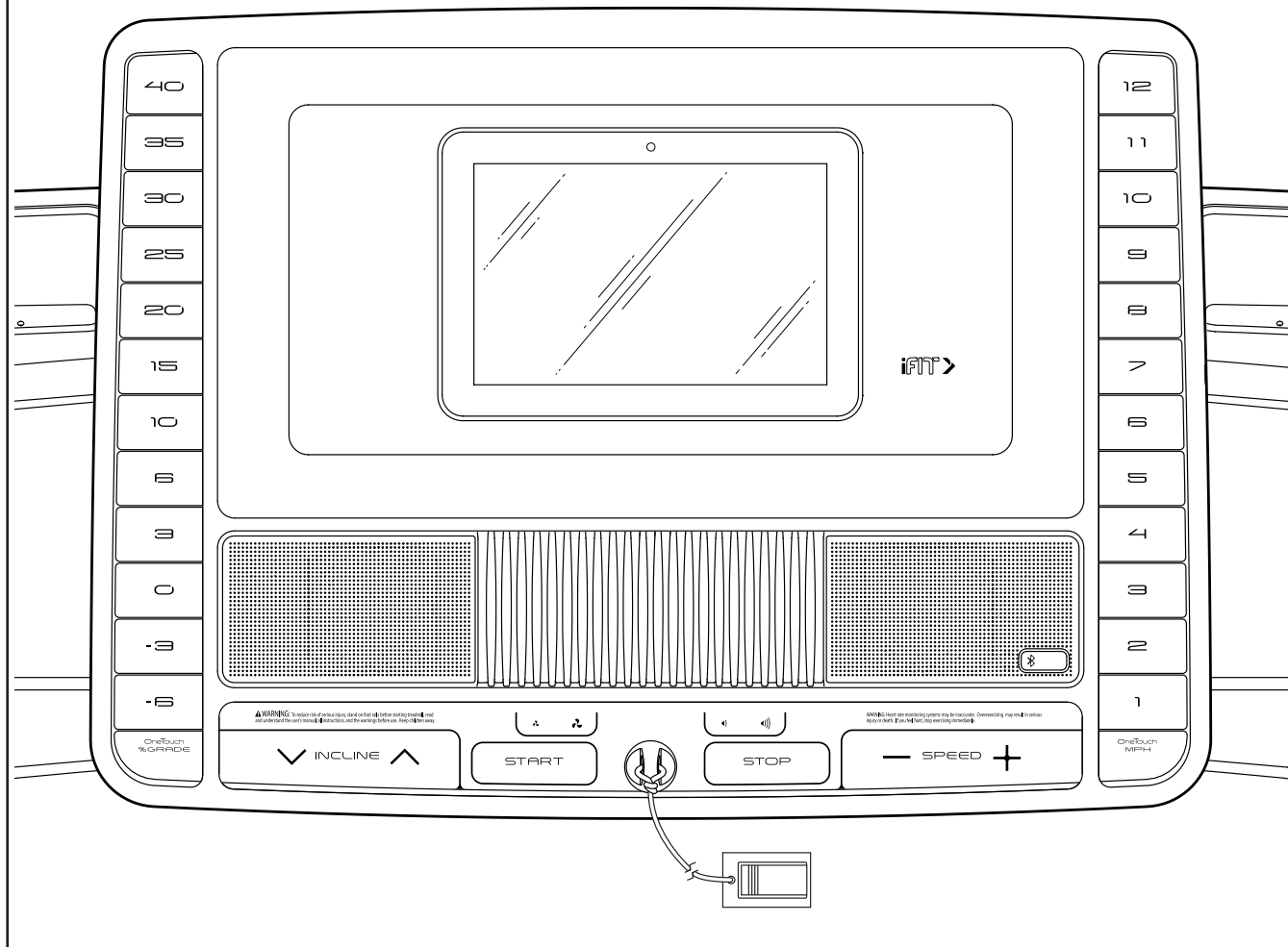

### FEATURES OF THE CONSOLE

The advanced incline trainer console offers a selection of features designed to make your workouts more effective and enjoyable.

The console features wireless technology that enables the console to connect to iFit. With iFit, you can access a large and varied workout library, create your own workouts, track your workout results, and access many other features.

When you use the manual mode, you can change the speed and incline of the incline trainer with the touch of a button. As you exercise, the console will display instant exercise feedback. You can also measure your heart rate using the chest heart rate monitor.

In addition, the console features a selection of workouts. Each workout automatically controls the speed and incline of the incline trainer as it guides you through an effective exercise session.

You can even listen to your favorite workout music or audio books with the console's sound system while you exercise.

**To turn on the power**, see page 17. **To learn how to use the touch screen**, see page 17. **To set up the console**, see page 18.



## HOW TO TURN ON THE POWER

**IMPORTANT:** If the incline trainer has been exposed to cold temperatures, allow it to warm to room temperature before you turn on the power. If you do not do this, you may damage the console displays or other electrical components.

Plug in the power cord (see page 15). Next, locate the power switch on the incline trainer frame near the power cord. Press the power switch into the reset position.

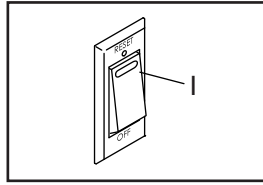

Next, stand on the foot rails of the incline trainer. Locate the clip (J) attached to the key (K), and slide the clip securely onto the waistband of your clothes. Then, insert the key into the console.

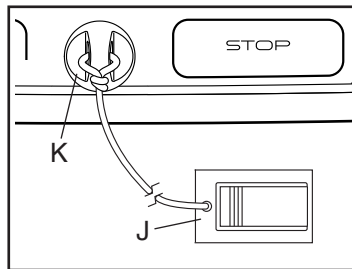

insert the key into the console. **Note:** It may take some time for the console to be ready for use. **IMPORTANT:** In an emergency, the key can be pulled from the console, causing the walking belt to slow to a stop. Test the clip by carefully taking a few steps backward; if the key is not pulled from the console, adjust the position of the clip.

Note: The console can display speed and distance in either miles or kilometers. To find which unit of measurement is selected, see HOW TO CHANGE CONSOLE SETTINGS on page 23. For simplicity, all instructions in this section refer to miles.

## HOW TO USE THE TOUCH SCREEN

The console features a tablet with a full-color touch screen. The following information will help you become familiar with the tablet's advanced technology.

- The console functions similarly to other tablets. You can slide or flick your finger against the screen to move certain images on the screen, such as the displays in a workout (see step 5 on page 19). However, you cannot zoom in and out by sliding your fingers on the screen.
- The screen is not pressure sensitive. You do not need to press hard on the screen.
- To type information into a text box, touch the text box to view the keyboard. To use numbers or other characters on the keyboard, touch the ?123 button. To view more characters, touch the ~[< button. Touch the ?123 button again to return to the number keyboard. To return to the letter keyboard, touch the ABC button. To use a capital character, touch the button with an upward-facing arrow. To use multiple capital characters, touch and hold the arrow button. To return to the lowercase keyboard, touch the arrow button again. To clear the last character, touch the button with a backward-facing arrow and an X.

## HOW TO SET UP THE CONSOLE

Before using the incline trainer for the first time, set up the console.

### 1. Connect to your wireless network.

To access the internet, download iFit workouts, and use several other features of the console, you must be connected to a wireless network. Follow the prompts on the screen to connect the console to your wireless network.

### 2. Customize settings.

Fill in the form on the screen to set the console to display the desired unit of measurement and your time zone. Note: If you need to change these settings later, see HOW CHANGE CONSOLE SETTINGS on page 23.

### 3. Log into or create an iFit account.

Provide your email address, and follow the prompts on the screen to sign up for or log into your iFit account.

### 4. Tour the console.

The first time you turn on the incline trainer, dialogue boxes on the screen will guide you through the features of the console.

### 5. Check for firmware updates.

First, touch your name or *Hello* on the screen, and then touch *Settings*. Next, select the maintenance section. Then, touch *Update* to check for firmware updates using your wireless network. See step 5 on page 24 for more information.

### 6. Calibrate the incline system.

First, touch your name or *Hello* on the screen. Next, select the settings main menu. Then, select the maintenance section, touch *Calibrate Incline*, and then touch *Begin* to calibrate the incline system. See step 6 on page 24 for more information.

The console is now ready for you to begin working out. The following pages explain the various workouts and other features that the console offers.

**To use the manual mode**, see page 19. **To use a map workout**, see page 20. **To use a draw your own map workout**, see page 21. **To use a distance or time workout**, see page 22. **To use the sled push feature**, see page 23.

**To view or change console settings**, see page 23. **To use the wireless network mode**, see page 25. **To use the sound system with a Bluetooth® device**, see page 26. **To use the sound system with an audio cable**, see page 26.

**IMPORTANT: If there are sheets of plastic on the console, remove the plastic. To prevent damage to the walking platform, wear clean athletic shoes while using the incline trainer. The first time you use the incline trainer, observe the alignment of the walking belt, and center the walking belt if necessary (see page 29).**

## HOW TO USE THE MANUAL MODE

### 1. Insert the key into the console.

See HOW TO TURN ON THE POWER on page 17.

**Note: It may take some time for the console to be ready for use.**

### 2. Select the main menu.

When you turn on the power, the main menu will appear after the console boots up. If you are in a workout or the settings menu, touch the back arrow or the x on the screen to return to the main menu.

### 3. Start the walking belt and adjust the speed.

Touch the Manual Start button on the screen or press the Start button on the console to start the walking belt. The walking belt will begin to move at a low speed. As you exercise, change the speed of the walking belt as desired by pressing the speed increase and decrease buttons. Each time you press one of the buttons, the speed setting will change by 0.1 mph; if you hold down the button, the speed setting will change in increments of 0.5 mph.

If you press one of the numbered speed buttons, the walking belt will gradually change speed until it reaches the selected speed setting.

**Note: When the incline setting is below 0% or above 15.5%, you will not be able to select the highest speed settings.**

To stop the walking belt, press the Stop button or tap the middle of the screen. To restart the walking belt, press the Start button.

### 4. Change the incline of the incline trainer as desired.

To change the incline of the incline trainer, press the incline increase and decrease buttons or one of the numbered incline buttons. Each time you press one of the buttons, the incline will gradually change until it reaches the selected incline setting.

**Note: If the walking belt is moving at a high speed and you adjust the incline below 0% or above 15.5%, the speed of the walking belt may automatically decrease.**

Note: The first time you use the incline trainer, you must calibrate the incline system (see step 6 on page 24).

### 5. Monitor your progress with the display modes.

The console offers several display modes. The display mode that you select will determine which workout information is shown. To select the desired display mode or view stats and charts, drag down on the screen. You can also touch the + button on the screen to view stats or charts.

As you walk or run on the incline trainer, the screen can show the following workout information:

- The incline level of the incline trainer
- Your vertical gain
- Your vertical loss
- The elapsed time
- The approximate number of calories you have burned
- The approximate number of calories you are burning per hour
- Your heart rate (see step 6)
- Your average heart rate
- The distance that you have walked or run
- Your pace
- The speed of the walking belt

- The average speed of the walking belt
- A track representing 1/4 mile (400 m)

If desired, adjust the volume by pressing the volume buttons on the console.

To pause the workout, tap the screen or press the Stop button on the console. To continue the workout, touch the Resume button or the Start button. To end the workout session, touch the Finish button.

## 6. Measure your heart rate if desired.

For information about the chest heart rate monitor, see page 14. Note: The console is compatible with Bluetooth® Smart heart rate monitors.

## 7. Turn on the fan if desired.

The fan features several speed settings. Press the fan buttons repeatedly to select a fan speed or to turn on or turn off the fan.

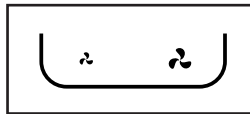

## 8. When you are finished exercising, remove the key from the console.

Step onto the foot rails and press the Stop button on the console or tap on the screen. Next, touch the Finish button. A workout summary will appear on the screen. If you wish to save one of the featured workouts for future use, you can add it as a favorite by touching the heart button on the screen. You may also be able to either save or publish your results using one of the options on the screen. Then, remove the key from the console and put it in a secure place.

When you are finished using the incline trainer, press the power switch into the off position and unplug the power cord. **IMPORTANT: If you do not do this, the incline trainer's electrical components may wear prematurely.**

## HOW TO USE A MAP WORKOUT

Note: To use a map workout, the console must be connected to a wireless network (see HOW TO USE THE WIRELESS NETWORK MODE on page 25). You will also need to be signed in to an active iFit account.

### 1. Insert the key into the console.

See HOW TO TURN ON THE POWER on page 17.

### 2. Select the main menu or the workout library.

Touch the Home or Browse buttons on the screen to select either the main menu or the workout library.

### 3. Select a map workout.

To select a map workout, touch the desired button on the screen. Note: The featured map workouts on your console will change periodically. If you wish to save one of the featured workouts for future use, you can add it as a favorite by touching the heart button on the screen. To draw your own map workout, see page 21.

The screen will show the duration and distance of the workout, and the approximate number of calories you will burn during the workout.

### 4. Start the workout.

Touch the Start button to start the workout. A moment after you touch the button, the walking belt will begin to move. Hold the handrails and begin walking.

During the workout, a map on the screen will show your progress.

The workout will function in the same way as the manual mode (see pages 19 to 20).

When you reach the end of the workout, the walking belt will slow to a stop, and a workout summary will appear on the screen. After you view the workout summary, touch the Finish button to return to the main menu. You may also be able to either save or publish your results using one of the options on the screen.

**5. Monitor your progress with the display modes.**

See step 5 on page 19.

**6. Measure your heart rate if desired.**

See step 6 on page 20.

**7. Turn on the fan if desired.**

See step 7 on page 20.

**8. When you are finished exercising, remove the key from the console.**

See step 8 on page 20.

**HOW TO USE A DRAW YOUR OWN MAP WORKOUT**

Note: To use a draw your own map workout, the console must be connected to a wireless network (see HOW TO USE THE WIRELESS NETWORK MODE on page 25). You will also need to be signed in to an active iFit account.

**1. Insert the key into the console.**

See HOW TO TURN ON THE POWER on page 17.

**2. Select a draw your own map workout.**

To select a draw your own map workout, touch the Create button on the screen.

**3. Draw your map.**

Navigate to the area on the map where you want to draw your workout by sliding your fingers on the screen. Tap the screen to add the start point for your workout. Then, tap the screen to add the end point for your workout. Note: If you want to start and end the workout at the same point, use the Loop or Out & Back buttons on the left side of the screen. You can also select whether you want your workout to snap to the road.

If you make a mistake, you can use the Undo button on the left side of the screen.

The screen will display the elevation and distance stats for your workout. If desired, you can change the default speed.

**4. Save your workout.**

Touch the Save New Workout button on the screen. If desired, change the title of the workout or add a description, and then press the > symbol on the screen.

**5. Start the workout.**

Touch the Start button on the screen to start the workout. A moment after you touch the button, the walking belt will begin to move. Hold the handrails and begin walking. See step 4 on page 20 for more information.

**6. Monitor your progress with the display modes.**

See step 5 on page 19.

**7. Measure your heart rate if desired.**

See step 6 on page 20.

**8. Turn on the fan if desired.**

See step 7 on page 20.

**9. When you are finished exercising, remove the key from the console.**

See step 8 on page 20.

## HOW TO USE A DISTANCE OR TIME WORKOUT

Note: To use a distance or time workout, the console must be connected to a wireless network (see HOW TO USE THE WIRELESS NETWORK MODE on page 25). An iFit account is also required.

### 1. Add workouts to your schedule on iFit.com.

On your computer, smartphone, tablet, or other device, open an internet browser, go to iFit.com, and sign in to your iFit account.

Next, navigate to Menu > Library on the website. Browse the workout programs in the library and join the desired workouts.

Then, navigate to Menu > Schedule to view your schedule. All of the workouts that you have joined will appear on your schedule; you can arrange or delete the workouts on your schedule as desired.

Take time to explore the iFit.com website before you log out.

### 2. Insert the key into the console.

See HOW TO TURN ON THE POWER on page 17.

### 3. Select the main menu.

See step 2 on page 19.

### 4. Log in to your iFit account.

If you have not already done so, touch the Login button to log in to your iFit account. The screen will ask for your iFit.com username and password. Enter them and touch the Submit button. Touch the Cancel button to exit the login screen.

### 5. Select a distance or time workout that you have previously added to your schedule on iFit.com.

Touch the calendar icon to download a distance or time workout from your schedule.

**Note: Before workouts will download, you must add them to your schedule on iFit.com.**

When you select a distance or time workout, the screen will show the name, the estimated duration, and the distance of the workout.

### 6. Start the workout.

See step 4 on page 20. Note: During a distance or time workout, the display will not show a map.

### 7. Monitor your progress with the display modes.

See step 5 on page 19. The screen will show the elapsed distance or time, and the remaining distance or time.

### 8. Measure your heart rate if desired.

See step 6 on page 20.

### 9. Turn on the fan if desired.

See step 7 on page 20.

### 10. When you are finished exercising, remove the key from the console.

See step 8 on page 20.

**For more information about iFit, go to iFit.com.**

## HOW TO USE THE SLED PUSH FEATURE

### 1. Insert the key into the console.

See HOW TO TURN ON THE POWER on page 17.

### 2. Select the main menu.

See step 2 on page 19.

### 3. Start the walking belt and adjust the speed to 1 mph. Then, adjust the incline to 0%.

See steps 3 and 4 on page 19. **IMPORTANT: Do not use the sled push feature when the incline trainer is turned off or when the speed setting is higher than 1 mph. Do not use the sled push feature when the incline setting is higher or lower than 0%.**

### 4. Grip the push bar or the sled grips with both hands (see page 7).

### 5. Use your body to manually move the walking belt at the desired speed.

## HOW TO CHANGE CONSOLE SETTINGS

**IMPORTANT: Some of the settings and features described may not be enabled.** Occasionally, a firmware update may cause your console to function slightly differently.

### 1. Select the settings main menu.

First, turn on the power and insert the key into the console (see HOW TO TURN ON THE POWER on page 19). Note: It may take a few moments for the console to be ready for use.

Next, select the main menu. When you turn on the console, the main menu will appear on the screen after the console boots up. If you are in a workout, touch the screen, touch *Pause*, touch *End*, and then touch *Finish* to return to the main menu.

Next, touch your name or *Hello* on the screen, and then touch *Settings*. The settings menu will appear on the screen.

### 2. Navigate the settings menus and change settings as desired.

Slide or flick the screen to scroll upward or downward if necessary. To view a settings menu, simply touch the menu name. To exit a menu, touch the back button (arrow symbol). You may be able to view and change settings in the following settings menus:

#### Account

- My Profile
- In Workout
- Manage Accounts

#### Equipment

- Equipment Info
- Equipment Settings
- Maintenance
- Wi-Fi

#### About

- Legal

### 3. Customize the unit of measurement and other settings.

To customize the unit of measurement, the time zone, or other settings, touch *Equipment Settings*, and then touch the desired settings.

The console can display speed and distance in either standard or metric units of measurement.

### 4. View machine information.

Touch *Equipment Info*, and then touch *Machine Info* to view information about your incline trainer.

### 5. Update the console firmware.

**For the best results, regularly check for firmware updates.** Touch *Maintenance*, and then touch *Update* to check for firmware updates using your wireless network. The update will begin automatically. **IMPORTANT: To avoid damaging the console, do not turn off or unplug the incline trainer while the firmware is being updated.**

The screen will show the progress of the update. When the update is complete, the incline trainer will turn off and then turn back on. If it does not, use the power switch (see HOW TO TURN ON THE POWER on page 19) to turn the incline trainer off, wait for a few seconds, and then turn it back on again. Note: It may take a few minutes for the console to be ready for use.

Note: Occasionally, a firmware update may cause the console to function slightly differently. These updates are always designed to improve your exercise experience.

### 6. Calibrate the incline system of the incline trainer.

Touch *Maintenance*, touch *Calibrate Incline*, and then touch *Begin* to calibrate the incline system. The incline trainer will automatically rise to the maximum incline level, lower to the minimum incline level, and then return to the starting position. This will calibrate the incline system. Touch the Cancel button to return to the Maintenance section. When the incline system is calibrated, touch the Finish button.

**IMPORTANT: Keep pets, feet, and other objects away from the incline trainer while the incline system is calibrating. In an emergency, pull the key from the console to stop the incline calibration..**

### 7. Exit the settings main menu.

If you are in a settings menu, touch the back button. Then, touch the close button (x symbol) to exit the settings main menu.



## HOW TO USE THE WIRELESS NETWORK MODE

The console features a wireless network mode that allows you to set up a wireless network connection.

### 1. Select the main menu.

See step 2 on page 19.

### 2. Select the wireless network mode.

Touch your name or *Hello* on the screen, and then touch the Wi-Fi® symbol to enter the wireless network mode.

### 3. Enable Wi-Fi.

Make sure that the Wi-Fi is enabled. If it is not, touch the Wi-Fi toggle button to enable a wireless connection.

### 4. Set up and manage a wireless network connection.

When Wi-Fi is enabled, the screen will show a list of available networks. Note: It may take several seconds for the list of wireless networks to appear.

Note: You must have your own wireless network and an 802.11b/g/n router with SSID broadcast enabled (hidden networks are not supported).

When a list of networks appears, touch the desired network. Note: You will need to know your network name (SSID). If your network has a password, you will also need to know the password.

An information box will ask if you want to connect to the wireless network. Touch the Connect button to connect to the network or touch the Cancel button to return to the list of networks. If the network has a password, touch the password entry box. A keyboard will appear on the screen. To view the password as you type it, touch the Show Password checkbox.

To use the keyboard, see HOW TO USE THE TOUCH SCREEN on page 17.

When the console is connected to your wireless network, a checkmark will appear next to the wireless network name. Then, touch the back button on the screen to return to the wireless network mode.

To disconnect from a wireless network, touch and hold the name of the wireless network and then touch the Forget Network button.

If you are having problems connecting to an encrypted network, make sure that your password is correct. Note: Passwords are case-sensitive.

Note: The console supports unsecured and secured (WEP, WPA™, and WPA2™) encryption. A broadband connection is recommended; performance depends on connection speed.

**Note: If you have questions after following these instructions, go to [support.iFit.com](http://support.iFit.com) for assistance.**

### 5. Exit the wireless network mode.

To exit the wireless network mode, touch the back button on the screen.

## HOW TO USE THE SOUND SYSTEM WITH A BLUETOOTH DEVICE

1. **Place or hold your Bluetooth-enabled device near the console.**
2. **Turn on your device's Bluetooth setting.**
3. **Pair your device to the console.**

Press and hold the Bluetooth button on the console's speaker grill for 3 seconds. The Bluetooth speakers will enter pairing mode. When your device and the console pair successfully, the audio from your device will play through the console's speakers.

Note: The console can save eight devices in its memory. If you have previously paired your device to the console, you can simply press the Bluetooth button to connect your device to the console.

4. **Erase the console's device memory if necessary.**

If you need to erase all the Bluetooth-enabled devices saved in the console's memory, press and hold the Bluetooth button for 10 seconds.

## HOW TO USE THE SOUND SYSTEM WITH AN AUDIO CABLE

To play music or audio books through the console sound system while you exercise, plug a 3.5 mm male to 3.5 mm male audio cable (not included) into the jack on the console and into a jack on your personal audio player; **make sure that the audio cable is fully plugged in. Note: To purchase an audio cable, see your local electronics store.**

Next, press the play button on your personal audio player. Adjust the volume level using the volume increase and decrease buttons on the console or the volume control on your personal audio player.

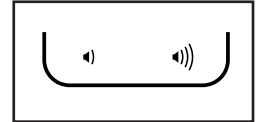

# HOW TO MOVE THE INCLINE TRAINER

Before moving the incline trainer, insert the key into the console (A), adjust the incline to the maximum incline level, remove the key, and unplug the power cord.

Due to the size and weight of the incline trainer, moving it requires two or three persons. Hold the uprights (B) firmly near the console (A). Tip the incline trainer back until it rolls freely on the wheels (C).

**CAUTION:** To decrease the possibility of injury or of damage to the incline trainer, do not lift the incline trainer by the plastic belly pan (D). Do not pull on the console.

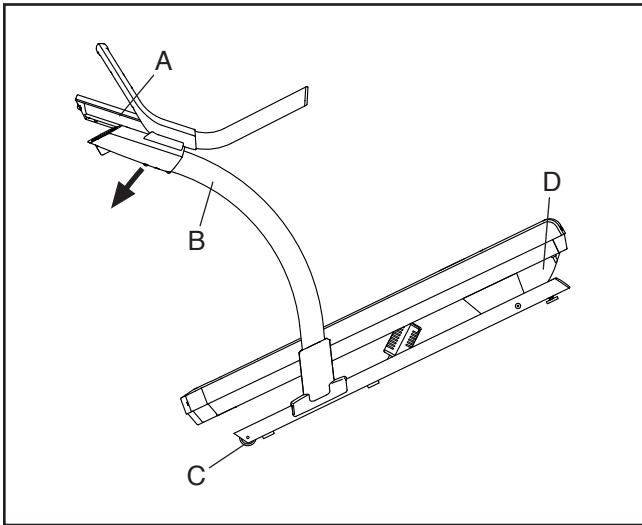

Carefully roll the incline trainer on the wheels to the desired location, and then lower it to the level position. **CAUTION:** To reduce the risk of injury, use extreme caution while moving the incline trainer. Do not attempt to move the incline trainer over uneven surfaces.

Make sure that the incline trainer rests firmly on the floor. If the incline trainer rocks even slightly, turn the Leveling Feet (77) as needed until the rocking motion is eliminated.

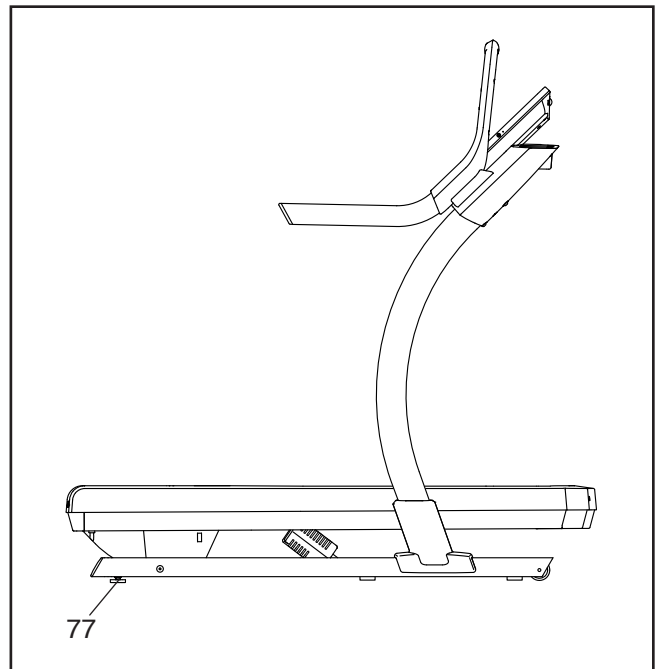

# MAINTENANCE AND TROUBLESHOOTING

## MAINTENANCE

Regular maintenance is important for optimal performance and to reduce wear. Inspect and properly tighten all parts each time the incline trainer is used. Replace any worn parts immediately.

Regularly clean the incline trainer and keep the walking belt clean and dry. First, **press the power switch into the off position and unplug the power cord**. Wipe exterior parts of the incline trainer with a damp cloth and a small amount of mild soap. **IMPORTANT: Do not spray liquids directly onto the incline trainer. To avoid damage to the console, keep liquids away from the console.** Then, thoroughly dry the incline trainer with a soft towel.

## TROUBLESHOOTING

**Most incline trainer problems can be solved by following the simple steps below. Find the symptom that applies, and follow the steps listed. If further assistance is needed, see the front cover of this manual.**

### SYMPTOM: The power does not turn on

- Make sure that the power cord is plugged into a surge suppressor, and that the surge suppressor is plugged into a properly grounded outlet (see page 15). Use only a surge suppressor that meets all of the specifications described on page 15. **IMPORTANT: If the incline trainer is connected to an AFCI-equipped outlet and your circuit breaker trips repeatedly when the incline trainer is used, see the front cover of this manual to purchase an arc filter.**

- After the power cord has been plugged in, make sure that the key is inserted into the console.
- Check the power switch located on the incline trainer frame near the power cord. If the switch protrudes as shown (A), the switch has tripped. To reset the power switch, wait for five minutes and then press the switch back in (B).

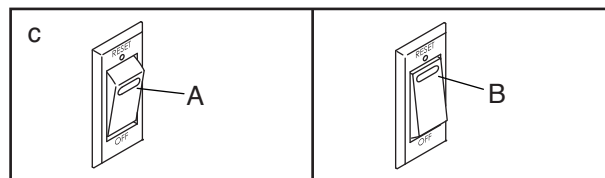

### SYMPTOM: The power turns off during use

- Check the power switch (see the drawing above). If the switch has tripped, wait for five minutes and then press the switch back in.
- Make sure that the power cord is plugged in. If the power cord is plugged in, unplug it, wait for five minutes, and then plug it back in.
- Remove the key from the console, and then reinsert it.
- If the incline trainer still will not run, please see the front cover of this manual.

**SYMPTOM: The walking belt slows when walked on**

- a. Use only a surge suppressor that meets all of the specifications described on page 15.
- b. If the walking belt is overtightened, incline trainer performance may decrease and the walking belt may become damaged. First, adjust the incline to 40%. Then, remove the key and **UNPLUG THE POWER CORD**. Using the hex key, turn both idler roller screws (C) counterclockwise, 1/4 of a turn. When the walking belt is properly tightened, you should be able to lift each edge of the walking belt 3 to 4 in. (8 to 10 cm) off the walking platform. Be careful to keep the walking belt centered. Then, plug in the power cord, insert the key, and walk on the incline trainer for a few minutes. Repeat until the walking belt is properly tightened.

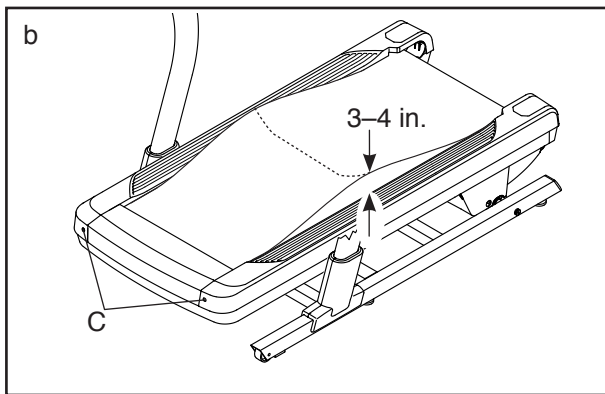

- c. The incline trainer features a walking belt coated with high-performance lubricant. **IMPORTANT: Never apply silicone spray or other substances to the walking belt or the walking platform unless instructed to do so by an authorized service representative. Such substances may deteriorate the walking belt and cause excessive wear.** If you suspect that the walking belt needs more lubricant, see the front cover of this manual.
- d. If the walking belt still slows when walked on, see the front cover of this manual.

**SYMPTOM: The walking belt is off-center or slips when walked on**

- a. **If the walking belt is off-center**, first adjust the incline to 40%. Next, remove the key and **UNPLUG THE POWER CORD**. **If the walking belt has shifted to the left**, use the hex key to turn the left idler roller screw clockwise 1/2 of a turn; **if the walking belt has shifted to the right**, turn the left idler roller screw counterclockwise 1/2 of a turn. Be careful not to overtighten the walking belt. Then, plug in the power cord, insert the key, and walk on the incline trainer for a few minutes. Repeat until the walking belt is centered.

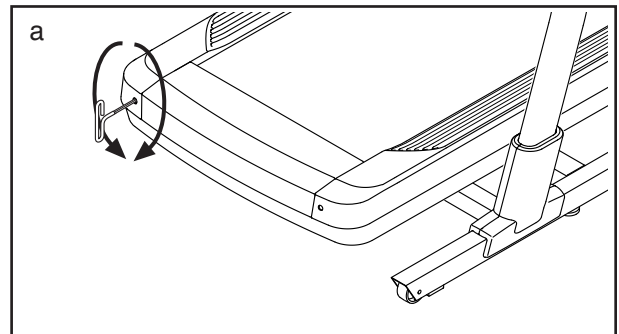

- b. **If the walking belt slips when walked on**, first adjust the incline to 40 percent. Next, remove the key and **UNPLUG THE POWER CORD**. Using the hex key, turn both idler roller screws clockwise, 1/4 of a turn. When the walking belt is correctly tightened, you should be able to lift each edge of the walking belt 3 to 4 in. (8 to 10 cm) off the walking platform. Be careful to keep the walking belt centered. Then, plug in the power cord, insert the key, and walk on the incline trainer for a few minutes. Repeat until the walking belt is properly tightened.

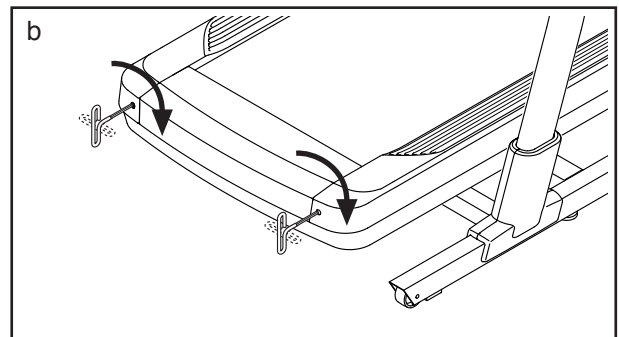

**SYMPTOM: The incline trainer will not connect to the wireless network**

- a. Make sure that the wireless settings on the console are correct (see page 25).
- b. Make sure that the settings for your wireless network are correct.
- c. If you still have questions, go to support.iFit.com.

**SYMPTOM: The incline of the incline trainer does not change correctly**

- a. Calibrate the incline system (see step 6 on page 24).

**SYMPTOM: The displays of the console do not function properly**

- a. If the console does not boot up properly, or if the console freezes and does not respond, reset the console to the factory default settings. **IMPORTANT: Doing this will erase all the custom settings you have made to the console.** Resetting the console requires two people. First, press the power switch into the off position. Next, locate the small reset opening (D) on the side of the console. Using a bent paper clip (E), press and hold the reset button inside the opening, and have a second person press the power switch into the on (reset) position. Continue holding the reset button (D) until the console turns on. When the reset operation is complete, the console will turn off and then turn back on. If it does not, use the power switch to turn the incline trainer off and then on again. Once the console turns on, check for firmware updates (see step 5 on page 24). Note: It may take a few minutes for the console to be ready for use.

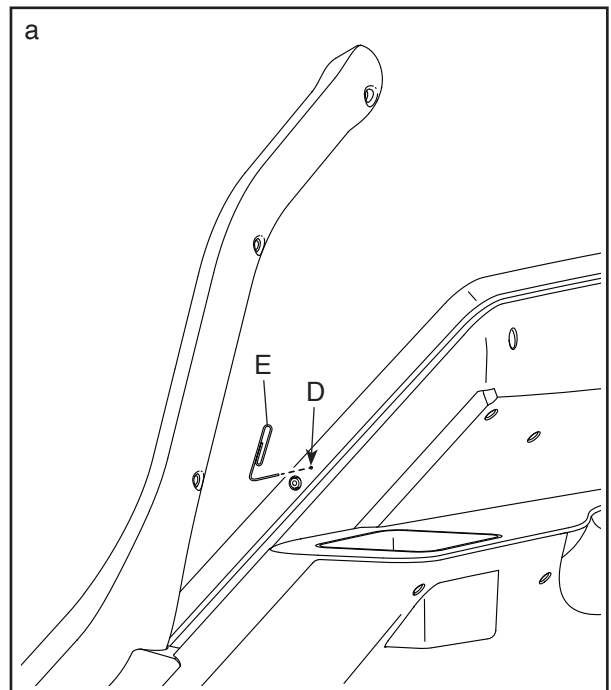

# EXERCISE GUIDELINES

**⚠️ WARNING:** Before beginning this or any exercise program, consult your physician. This is especially important for persons over age 35 or persons with pre-existing health problems.

The heart rate monitor is not a medical device. Various factors may affect the accuracy of heart rate readings. The heart rate monitor is intended only as an exercise aid in determining heart rate trends in general.

These guidelines will help you to plan your exercise program. For detailed exercise information, obtain a reputable book or consult your physician. Remember, proper nutrition and adequate rest are essential for successful results.

## EXERCISE INTENSITY

Whether your goal is to burn fat or to strengthen your cardiovascular system, exercising at the proper intensity is the key to achieving results. You can use your heart rate as a guide to find the proper intensity level. The chart below shows recommended heart rates for fat burning and aerobic exercise.

165	155	145	140	130	125	115	❤️
145	138	130	125	118	110	103	❤️
125	120	115	110	105	95	90	❤️
<hr/>							
20	30	40	50	60	70	80	

To find the proper intensity level, find your age at the bottom of the chart (ages are rounded off to the nearest ten years). The three numbers listed above your age define your “training zone.” The lowest number is the heart rate for fat burning, the middle number is the heart rate for maximum fat burning, and the highest number is the heart rate for aerobic exercise.

**Burning Fat**—To burn fat effectively, you must exercise at a low intensity level for a sustained period of time. During the first few minutes of exercise, your body uses carbohydrate calories for energy. Only after the first few minutes of exercise does your body begin to use stored fat calories for energy. If your goal is to burn fat, adjust the intensity of your exercise until your heart rate is near the lowest number in your training zone. For maximum fat burning, exercise with your heart rate near the middle number in your training zone.

**Aerobic Exercise**—If your goal is to strengthen your cardiovascular system, you must perform aerobic exercise, which is activity that requires large amounts of oxygen for prolonged periods of time. For aerobic exercise, adjust the intensity of your exercise until your heart rate is near the highest number in your training zone.

## WORKOUT GUIDELINES

**Warming Up**—Start with 5 to 10 minutes of stretching and light exercise. A warm-up increases your body temperature, heart rate, and circulation in preparation for exercise.

**Training Zone Exercise**—Exercise for 20 to 30 minutes with your heart rate in your training zone. (During the first few weeks of your exercise program, do not keep your heart rate in your training zone for longer than 20 minutes.) Breathe regularly and deeply as you exercise; never hold your breath.

**Cooling Down**—Finish with 5 to 10 minutes of stretching. Stretching increases the flexibility of your muscles and helps to prevent post-exercise problems.

## EXERCISE FREQUENCY

To maintain or improve your condition, complete three workouts each week, with at least one day of rest between workouts. After a few months of regular exercise, you may complete up to five workouts each week, if desired. Remember, the key to success is to make exercise a regular and enjoyable part of your everyday life.

## SUGGESTED STRETCHES

The correct form for several basic stretches is shown at the right. Move slowly as you stretch—never bounce.

### 1. Toe Touch Stretch

Stand with your knees bent slightly and slowly bend forward from your hips. Allow your back and shoulders to relax as you reach down toward your toes as far as possible. Hold for 15 counts, then relax. Repeat 3 times. Stretches: Hamstrings, back of knees and back.

### 2. Hamstring Stretch

Sit with one leg extended. Bring the sole of the opposite foot toward you and rest it against the inner thigh of your extended leg. Reach toward your toes as far as possible. Hold for 15 counts, then relax. Repeat 3 times for each leg. Stretches: Hamstrings, lower back and groin.

### 3. Calf/Achilles Stretch

With one leg in front of the other, reach forward and place your hands against a wall. Keep your back leg straight and your back foot flat on the floor. Bend your front leg, lean forward and move your hips toward the wall. Hold for 15 counts, then relax. Repeat 3 times for each leg. To cause further stretching of the achilles tendons, bend your back leg as well. Stretches: Calves, achilles tendons and ankles.

### 4. Quadriceps Stretch

With one hand against a wall for balance, reach back and grasp one foot with your other hand. Bring your heel as close to your buttocks as possible. Hold for 15 counts, then relax. Repeat 3 times for each leg. Stretches: Quadriceps and hip muscles.

### 5. Inner Thigh Stretch

Sit with the soles of your feet together and your knees outward. Pull your feet toward your groin area as far as possible. Hold for 15 counts, then relax. Repeat 3 times. Stretches: Quadriceps and hip muscles.

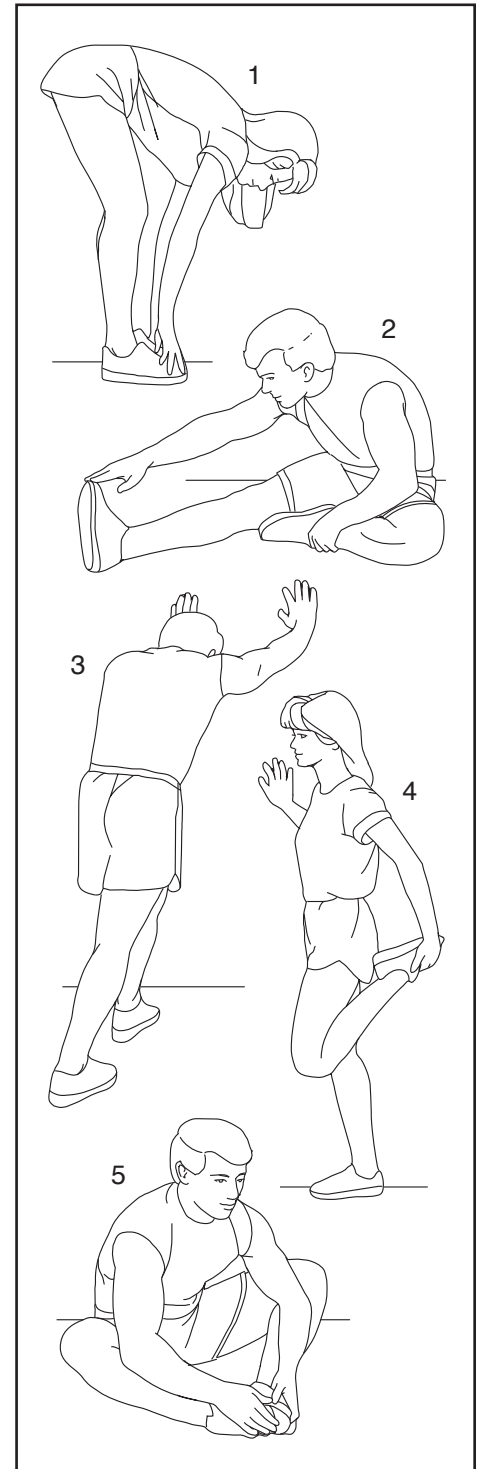



# PART LIST

Model No. NTL22019.2 R0520A

Key No.	Qty.	Description	Key No.	Qty.	Description
1	4	3/8" x 5 1/2" Screw	49	8	Cushion Cap
2	6	#8 x 1 1/4" Screw	50	4	Spring
3	16	3/8" Star Washer	51	4	Cushion
4	2	#8 x 3/4" Pan Head Tek Screw	52	1	Base Wire
5	54	#8 x 3/4" Screw	53	4	Rubber Cushion
6	4	#8 Belt Guide Screw	54	2	Large Pivot Bushing
7	7	#8 x 1/2" Screw	55	1	Electronics Cover
8	4	Fan Screw	56	1	Incline Motor Top Cover
9	8	#8 x 3/4" Washer Head Screw	57	4	#8 x 3/4" Machine Screw
10	8	#8 x 5/8" Screw	58	1	Incline Motor Bottom Cover
11	4	5/16" x 1 1/2" Screw	59	8	Incline Motor Bushing
12	2	1/4" x 1/2" Screw	60	1	Incline Motor
13	4	1/4" x 2 1/2" Screw	61	1	Electronics Bracket
14	1	3/8" x 1 1/2" Bolt	62	1	Controller
15	1	3/8" x 2 3/8" Bolt	63	1	Resistor
16	12	Hood Clip	64	1	Drive Motor
17	13	#8 x 1/2" Washer Head Screw	65	2	5/16" Star Washer
18	4	3/8" x 3 1/4" Screw	66	1	Frame
19	6	3/8" Washer	67	1	Chest Heart Rate Monitor
20	2	5/16" Motor Bolt	68	1	Left Outside Upright Cover
21	2	3/8" x 2 3/8" Screw	69	1	Left Inside Upright Cover
22	4	3/8" x 2 3/4" Screw	70	1	Right Inside Upright Cover
23	3	#8 Star Washer	71	1	Right Outside Upright Cover
24	1	Console Back	72	2	Wheel
25	4	5/16" Flat Washer	73	4	Base Pad
26	4	3/8" Nut	74	1	Base
27	4	5/16" Nut	75	1	Upright Wire
28	1	1/4" Nut	76	3	Round Grommet
29	2	Belt Guide	77	2	Leveling Foot
30	1	Walking Platform	78	2	Axle
31	1	Walking Belt	79	2	Base Cap
32	1	Left Foot Rail	80	1	Warning Decal
33	1	Right Foot Rail	81	2	Caution Decal
34	1	Idler Roller	82	1	Left Handrail
35	1	Belly Pan Cover	83	1	Upright
36	1	Belly Pan	84	2	Console Ground Wire
37	1	Power Switch	85	1	Crossbar
38	2	Belly Pan Grommet	86	2	Handrail Cap
39	1	Grommet	87	2	5/16" x 1" Screw
40	1	Power Cord	88	1	Key
41	8	Tie	89	1	Right Handrail Top
42	1	Drive Roller/Pulley	90	1	Left Handrail Top
43	1	Right Foot Rail Cover	91	1	Left Tray
44	1	Left Foot Rail Cover	92	1	Console Base
45	4	Small Pivot Bushing	93	1	Console
46	1	Drive Belt	94	1	Right Tray
47	1	Front Hood Cover	95	4	#8 x 1" Screw
48	1	Front Hood	96	2	#8 x 3/4" Console Screw

Key No.	Qty.	Description	Key No.	Qty.	Description
97	1	Right Handrail	101	2	Fan
98	1	Left Handrail Bottom	102	6	1/4" Flat Washer
99	1	Right Handrail Bottom	*	–	User's Manual
100	4	3/8" x 3/4" Screw			

Note: Specifications are subject to change without notice. For information about ordering replacement parts, see the back cover of this manual. \*These parts are not illustrated.

# EXPLODED DRAWING A

Model No. NTL22019.2 R0520A

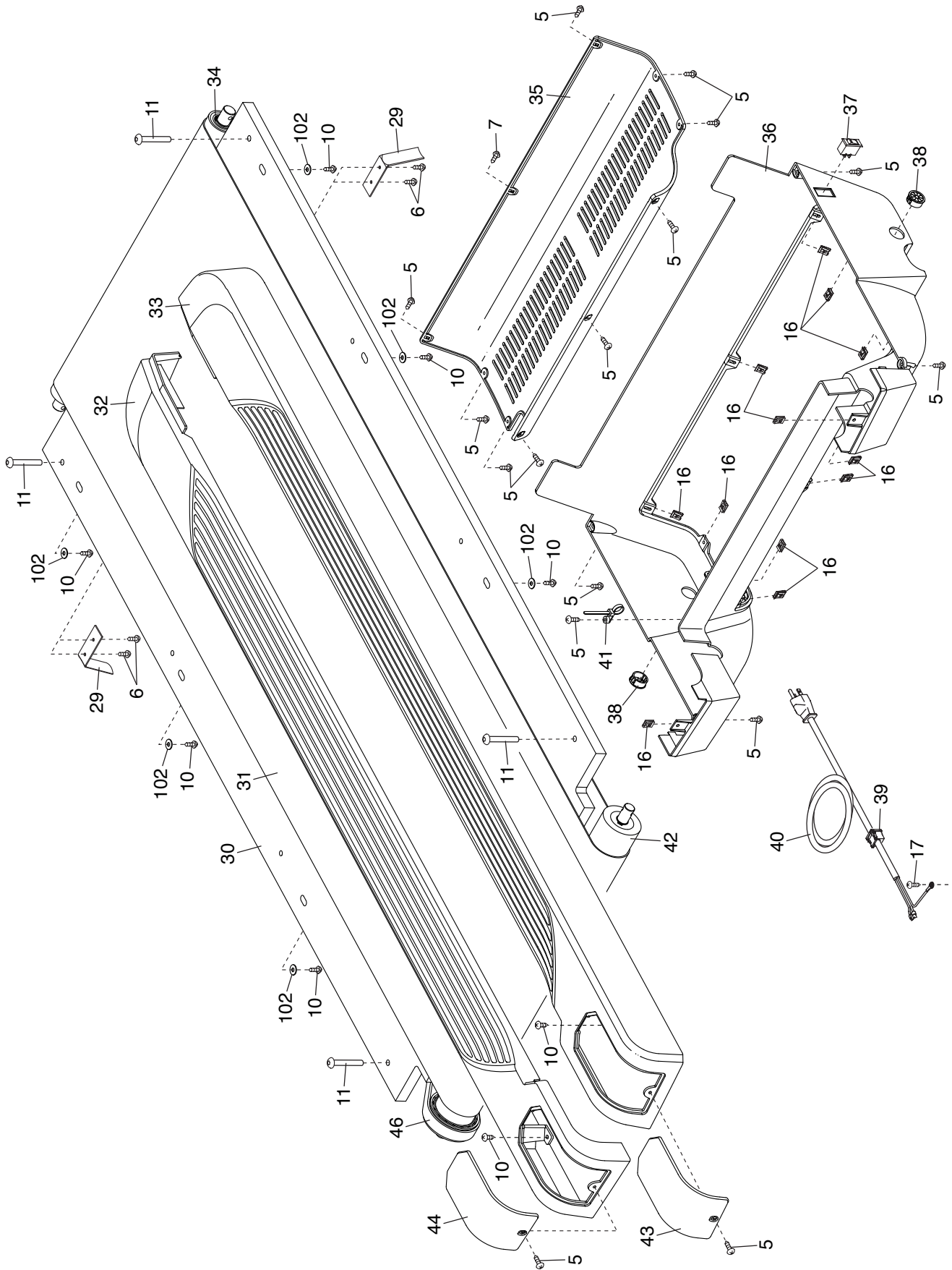

# EXPLODED DRAWING B

Model No. NTL22019.2 R0520A

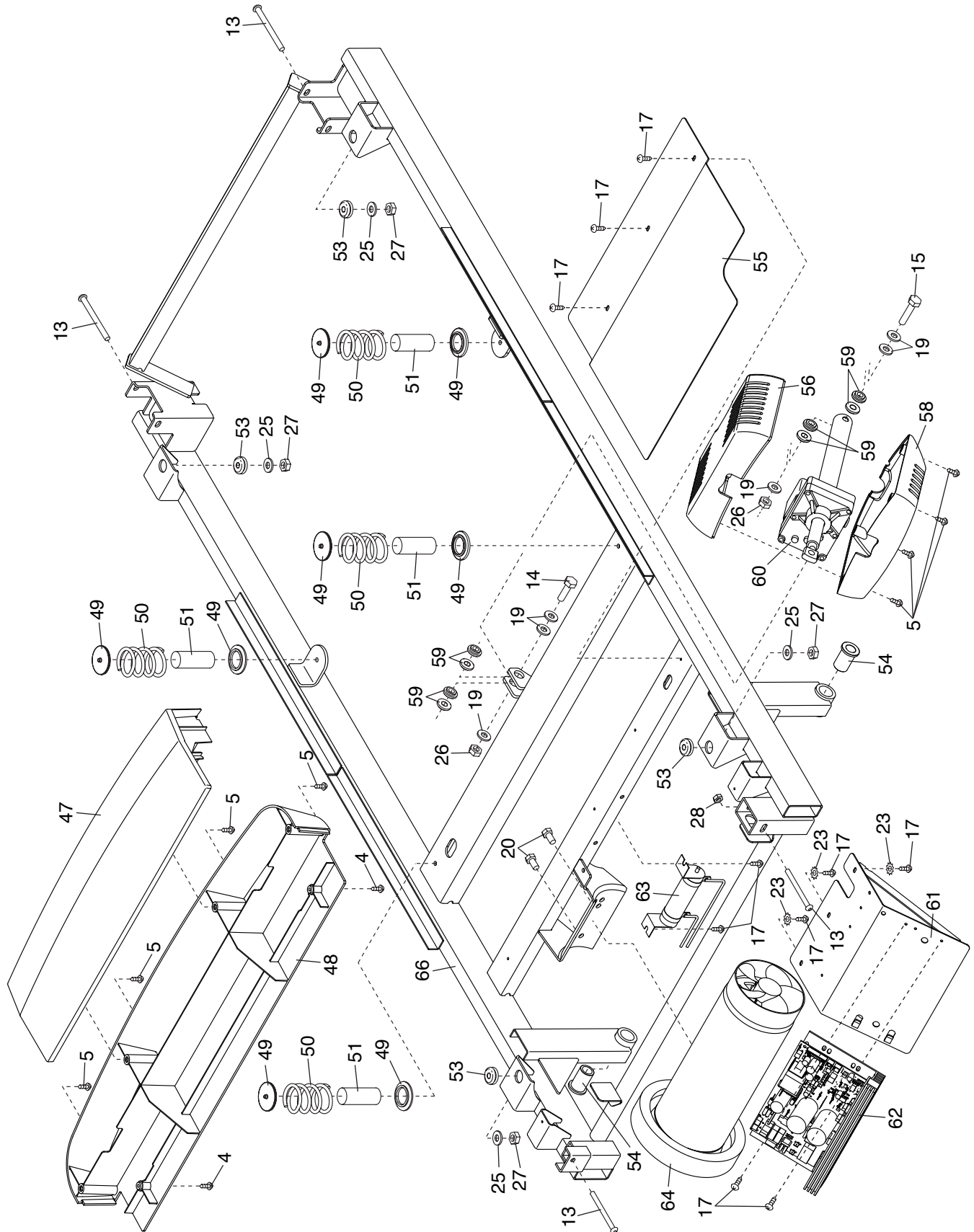

# EXPLODED DRAWING C

Model No. NTL22019.2 R0520A

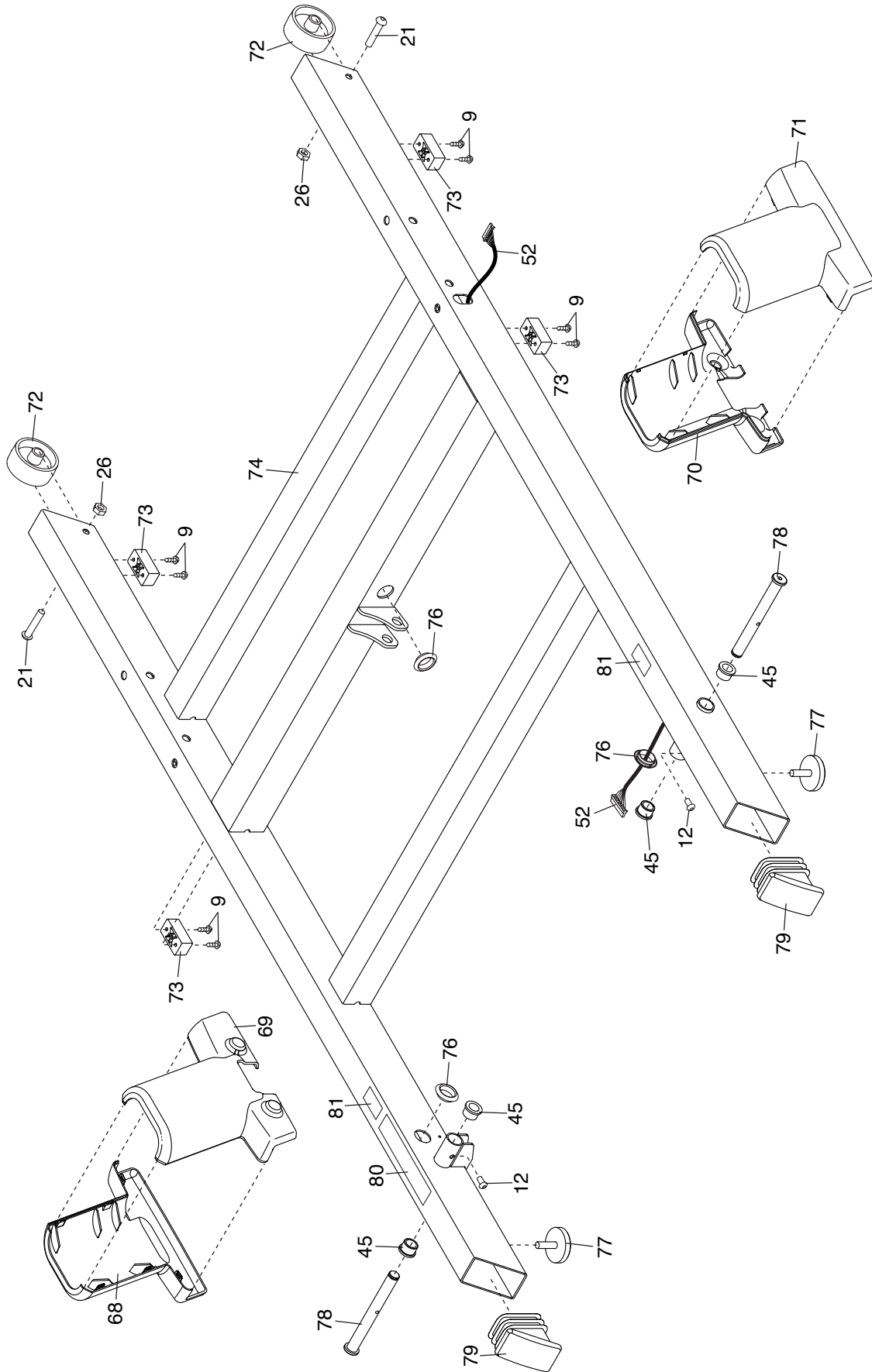

# EXPLODED DRAWING D

Model No. NTL22019.2 R0520A

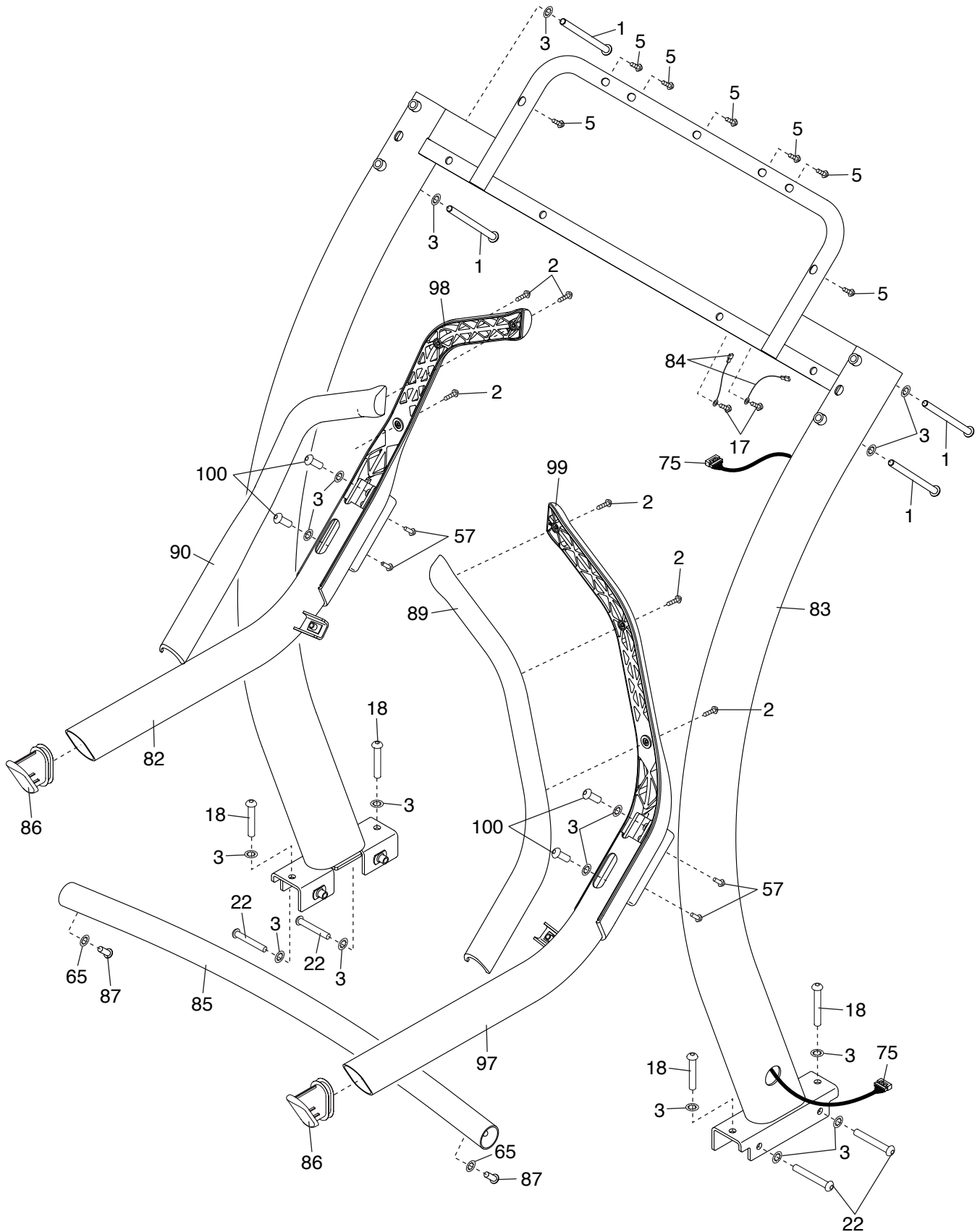

# EXPLODED DRAWING E

Model No. NTL22019.2 R0520A

