

NordicTrack[®]

COMMERCIAL 14.9

nordictrack.com

Model No. NTEL71418.5

Serial No. _____

Write the serial number in the space above for reference.

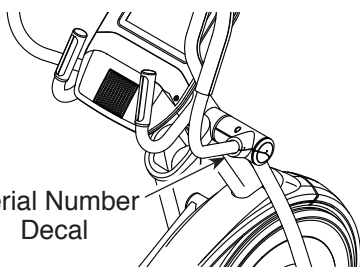

Serial Number
Decal

USER'S MANUAL

ACTIVATE YOUR WARRANTY

To register your product and activate your warranty today, go to my.nordictrack.com.

CUSTOMER CARE

For service at any time, go to support.nordictrack.com.

Or call 1-800-TO-BE-FIT
(1-800-862-3348)

Mon.–Fri. 6 a.m.–6 p.m. MT
Sat. 8 a.m.–12 p.m. MT

Please do not contact the store.

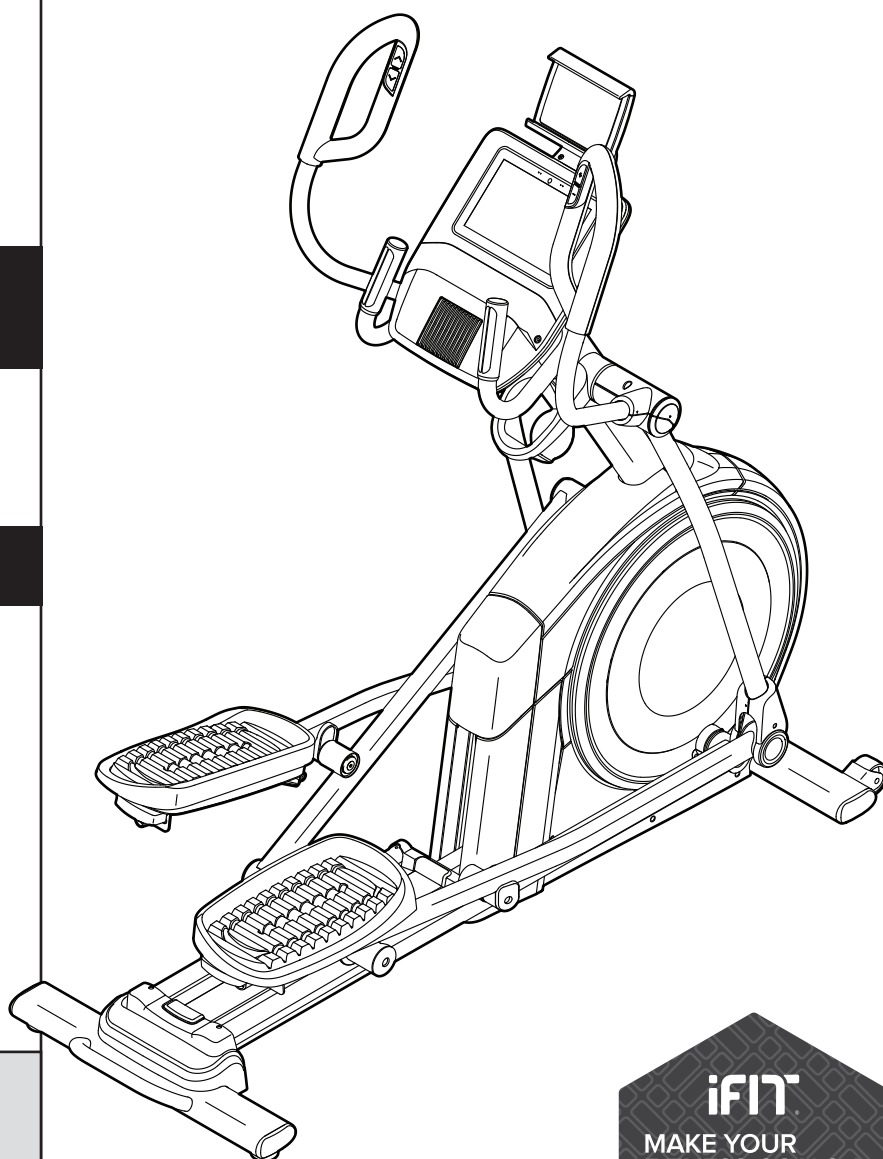

⚠ CAUTION

Read all precautions and instructions in this manual before using this equipment. Keep this manual for future reference.

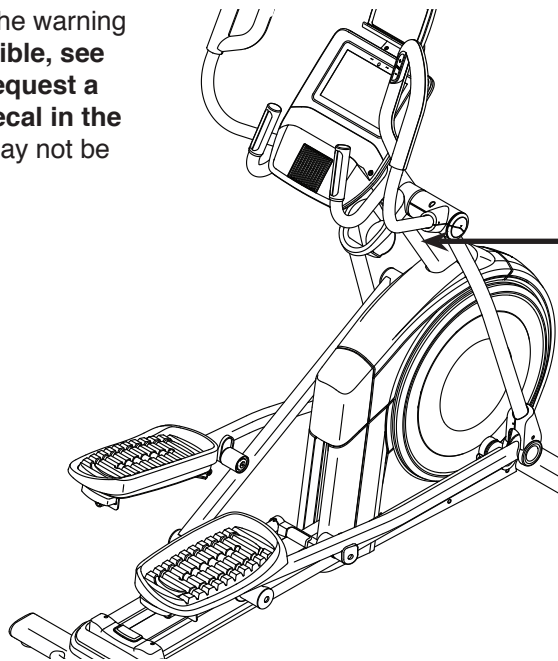

TABLE OF CONTENTS

WARNING DECAL PLACEMENT	2
IMPORTANT PRECAUTIONS	3
BEFORE YOU BEGIN	6
PART IDENTIFICATION CHART	7
ASSEMBLY	8
THE CHEST HEART RATE MONITOR	16
HOW TO USE THE ELLIPTICAL	17
HOW TO USE THE CONSOLE	20
FCC INFORMATION	31
MAINTENANCE AND TROUBLESHOOTING	32
EXERCISE GUIDELINES	34
PART LIST	35
EXPLODED DRAWING	37
ORDERING REPLACEMENT PARTS	Back Cover
LIMITED WARRANTY	Back Cover

WARNING DECAL PLACEMENT

This drawing shows the location(s) of the warning decal(s). **If a decal is missing or illegible, see the front cover of this manual and request a free replacement decal. Apply the decal in the location shown.** Note: The decal(s) may not be shown at actual size.



WARNING

- Misuse of this machine may result in serious injury.
- Read user's manual prior to use and follow all warnings and instructions.
- Do not allow children on or around machine.
- Pedals continue to spin when you stop pedaling.
- Spinning pedals can cause injury.
- Reduce pedal speed in a controlled manner.
- User weight must not exceed 350 lbs / 159 kgs.
- This product should always be used on a level surface.
- This product is not intended for therapeutic use.
- Replace label if damaged, illegible, or removed.



NORDICTRACK and IFIT are registered trademarks of ICON Health & Fitness, Inc. Google Maps is a trademark of Google LLC. The Bluetooth® word mark and logos are registered trademarks of Bluetooth SIG, Inc. and are used under license. Wi-Fi is a registered trademark of Wi-Fi Alliance. WPA and WPA2 are trademarks of Wi-Fi Alliance.

IMPORTANT PRECAUTIONS

⚠️ WARNING: To reduce the risk of burns, fire, electric shock, or injury to persons, read all important precautions and instructions in this manual and all warnings on your elliptical before using your elliptical. ICON assumes no responsibility for personal injury or property damage sustained by or through the use of this product.

1. It is the responsibility of the owner to ensure that all users of the elliptical are adequately informed of all precautions.
2. Before beginning any exercise program, consult your physician. This is especially important for persons over age 35 or persons with pre-existing health problems.
3. The elliptical is not intended for use by persons with reduced physical, sensory, or mental capabilities or lack of experience and knowledge, unless they are given supervision or instruction about use of the elliptical by someone responsible for their safety.
4. Use the elliptical only as described in this manual.
5. The elliptical is intended for home use only. Do not use the elliptical in a commercial, rental, or institutional setting.
6. Keep the elliptical indoors, away from moisture and dust. Do not put the elliptical in a garage or covered patio, or near water.
7. Place the elliptical on a level surface, with at least 3 ft. (0.9 m) of clearance in the front and rear of the elliptical and 2 ft. (0.6 m) on each side. To protect the floor or carpet from damage, place a mat under the elliptical.
8. Inspect and properly tighten all parts each time the elliptical is used. Replace any worn parts immediately.
9. When connecting the power cord, plug the power cord into a grounded circuit.
10. Do not modify the power cord or use an adapter to connect the power cord to an improper receptacle. Keep the power cord away from heated surfaces. Do not use an extension cord.
11. Do not operate the elliptical if the power cord or plug is damaged, or if the elliptical is not working properly.
12. **DANGER:** Always unplug the power cord and switch the power switch to the off position when the elliptical is not in use and before cleaning the elliptical. Servicing other than the procedures in this manual should be performed by an authorized service representative only.
13. Keep children under age 16 and pets away from the elliptical at all times.
14. The elliptical should not be used by persons weighing more than 350 lbs. (159 kg).
15. Wear appropriate clothes while exercising; do not wear loose clothes that could become caught on the elliptical. Always wear athletic shoes for foot protection while exercising.
16. Hold the handlebars or the upper body arms when mounting, dismounting, or using the elliptical. Before mounting or dismounting, bring the pedals to a stop with the pedal on the mounting or dismounting side in its lowest position.
17. The heart rate monitor is not a medical device. Various factors may affect the accuracy of heart rate readings. The heart rate monitor is intended only as an exercise aid in determining heart rate trends in general.

18. The elliptical does not have a freewheel; the pedals will continue to move until the fly-wheel stops. Reduce your pedaling speed in a controlled way.

19. Keep your back straight while using the elliptical; do not arch your back.

20. Over exercising may result in serious injury or death. If you feel faint, if you become short of breath, or if you experience pain while exercising, stop immediately and cool down.

SAVE THESE INSTRUCTIONS

PROTECT

YOUR FITNESS EQUIPMENT
WITH AN EXTENDED SERVICE PLAN



Your new fitness equipment is not an ordinary purchase; it is an investment in your health and well being for years to come.

As the leading provider of manufacturer's extended service plans, ICON strives to protect your equipment and your future.

Please review the following service plans and find one that best fits your needs.

PREVENTIVE MAINTENANCE SERVICE PLANS

Equipment Price	3-Year Plan	5-Year Plan
\$0.00 to \$1000.00	\$199.99	\$289.99
\$1001.00 to \$1500.00	\$259.99	\$379.99
\$1501.00 to \$2500.00	\$339.99	\$489.99
(Bikes/Systems Only) \$0.00 to \$2500.00	\$139.99	NA

Features:

- Includes an annual preventive maintenance and performance check at your convenience
- Unlimited in-home repairs; no shipping required
- Covers parts and labor on all manufacturer's defects, as well as wear and tear on parts
- Up to 5 years of coverage available

STANDARD SERVICE PLANS

Equipment Price	1-Year Plan	2-Year Plan	3-Year Plan
\$0.00 to \$300.00	\$29.99	\$39.99	\$59.99
\$301.00 to \$1000.00	\$89.99	\$119.99	\$149.99
\$1001.00 to \$2000.00	\$109.99	\$139.99	\$179.99
\$2001.00 to \$3000.00	\$179.99	\$209.99	\$239.99

Features:

- Unlimited in-home repairs; no shipping required
- Covers parts and labor on all manufacturer's defects, as well as wear and tear on parts
- Up to 3 years of coverage available

To protect your fitness equipment today, please
call Customer Care at **1-800-677-3838.**
Or, visit us online at **www.utserv.com.**



BEFORE YOU BEGIN

Thank you for selecting the revolutionary NORDICTRACK® COMMERCIAL 14.9 elliptical. The COMMERCIAL 14.9 elliptical provides an impressive selection of features designed to make your workouts at home more effective and enjoyable.

For your benefit, read this manual carefully before you use the elliptical. If you have questions after

reading this manual, please see the front cover of this manual. To help us assist you, note the product model number and serial number before contacting us. The model number and the location of the serial number decal are shown on the front cover of this manual.

Before reading further, please familiarize yourself with the parts that are labeled in the drawing below.

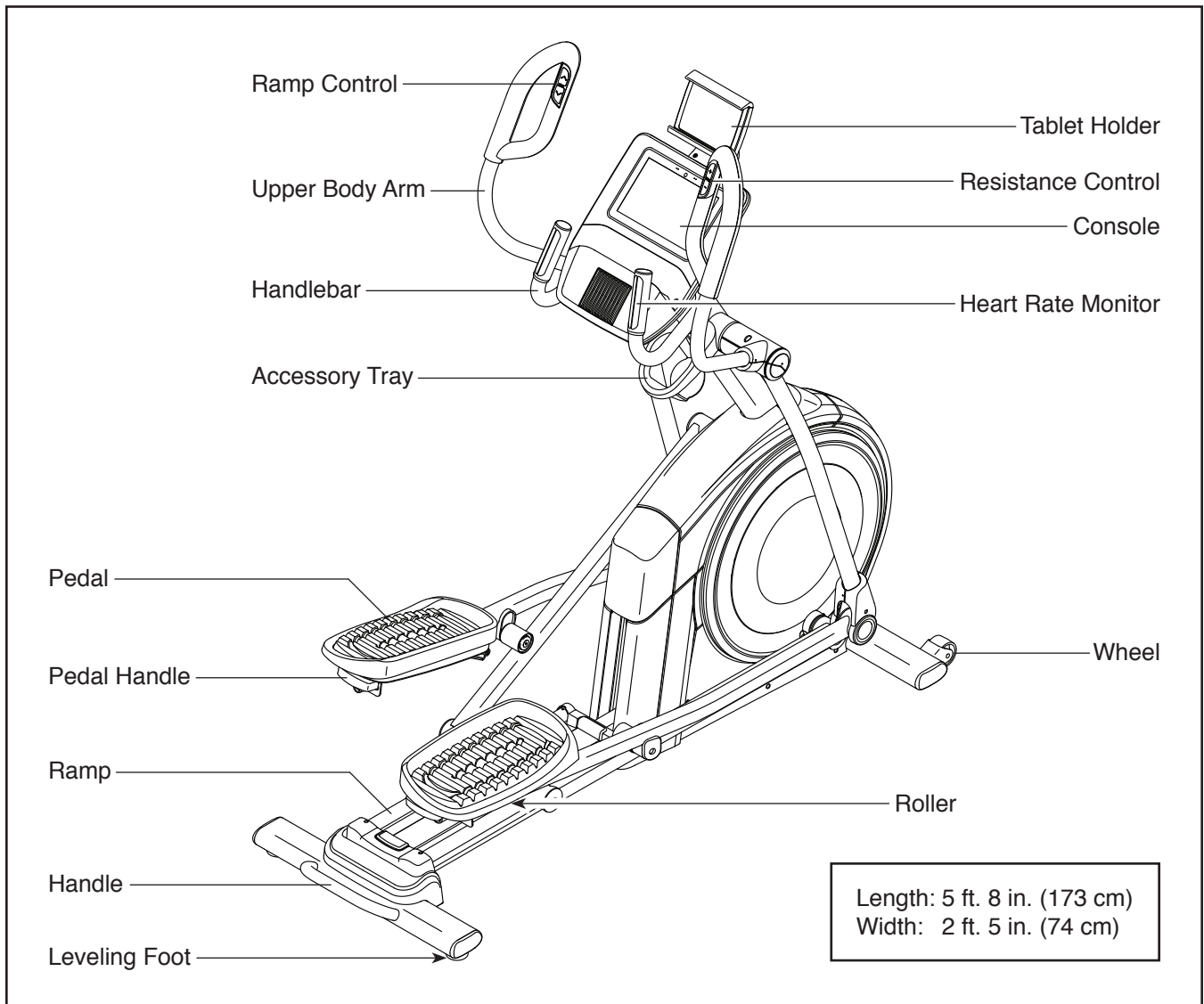



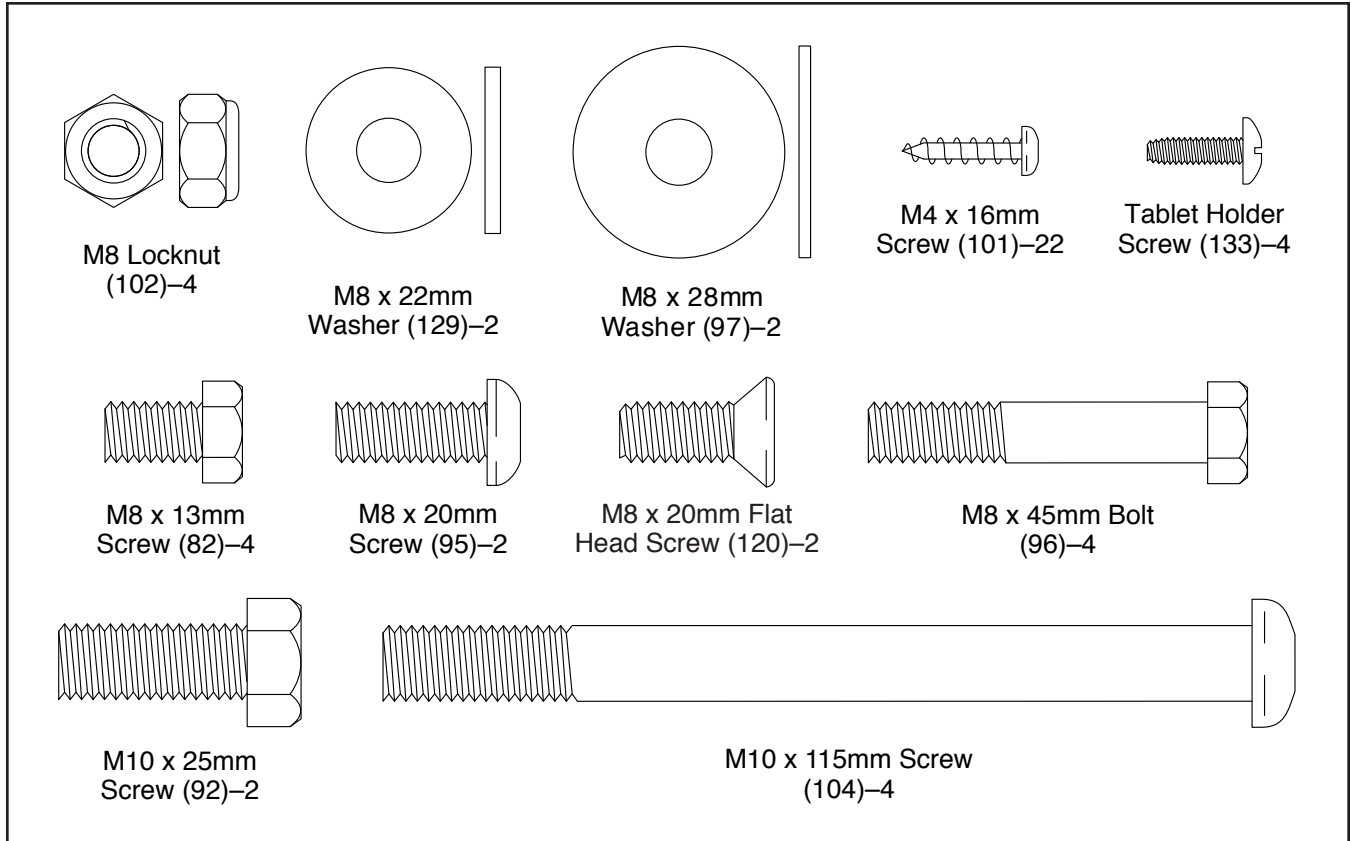

PART IDENTIFICATION CHART

Use the drawings below to identify the small parts needed for assembly. The number in parentheses below each drawing is the key number of the part, from the PART LIST near the end of this manual. The number following the key number is the quantity needed for assembly. **Note: If a part is not in the hardware kit, check to see if it has been preassembled. Extra parts may be included.**

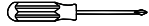

ASSEMBLY

- Assembly requires two persons.
- Place all parts in a cleared area and remove the packing materials. Do not dispose of the packing materials until you finish all assembly steps.
- Left parts are marked “L” or “Left” and right parts are marked “R” or “Right.”
- To identify small parts, see page 7.
- In addition to the included tool(s), assembly requires the following tools:

- one Phillips screwdriver 
- two adjustable wrenches 
- one rubber mallet 
- one pair of scissors 

Assembly may be easier if you have a set of wrenches. To avoid damaging parts, do not use power tools.

1. Go to my.nordictrack.com on your computer and register your product.

- documents your ownership
- activates your warranty
- ensures priority customer support if assistance is ever needed

Note: If you do not have internet access, call Customer Care (see the front cover of this manual) and register your product.

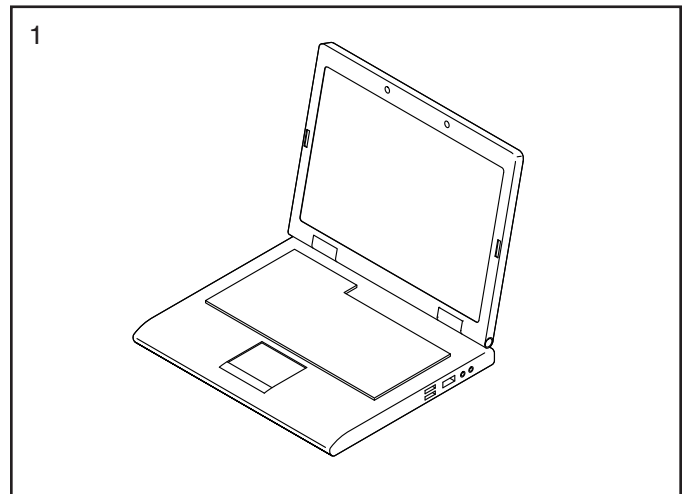

2. With the help of a second person, place some of the packing materials (not shown) under the rear of the Frame (1). **Have the second person hold the Frame to prevent it from tipping while you complete this step.**

If there are shipping supports attached to the rear of the Frame (1), remove the screws from the shipping supports, and discard the screws and the shipping supports.

Next, attach the Rear Stabilizer (2) to the Frame (1) with two M10 x 115mm Screws (104).

Then, remove the packing materials from under the rear of the Frame (1).

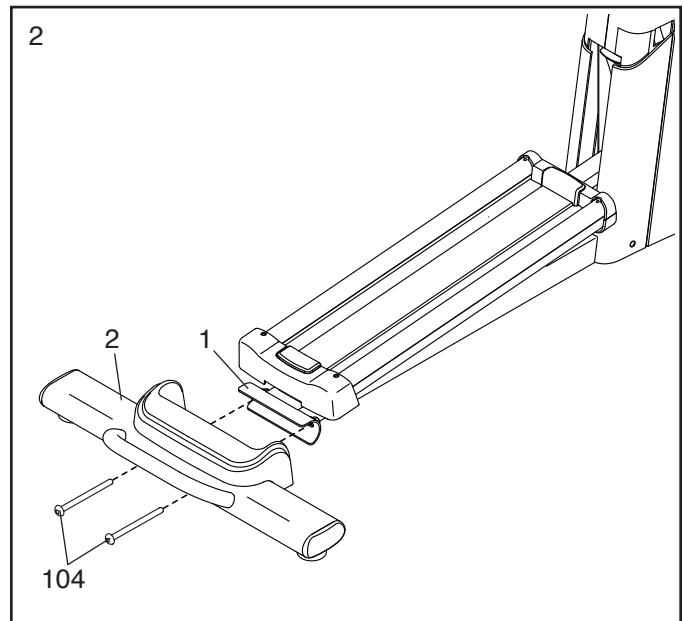

3. With the help of a second person, place some of the packing materials (not shown) under the front of the Frame (1). **Have the second person hold the Frame to prevent it from tipping while you complete this step.**

If there are shipping supports attached to the front of the Frame (1), remove the screws from the shipping supports, and discard the screws and the shipping supports.

Next, attach the Front Stabilizer (6) to the Frame (1) with two M10 x 115mm Screws (104).

Then, remove the packing materials from under the front of the Frame (1).

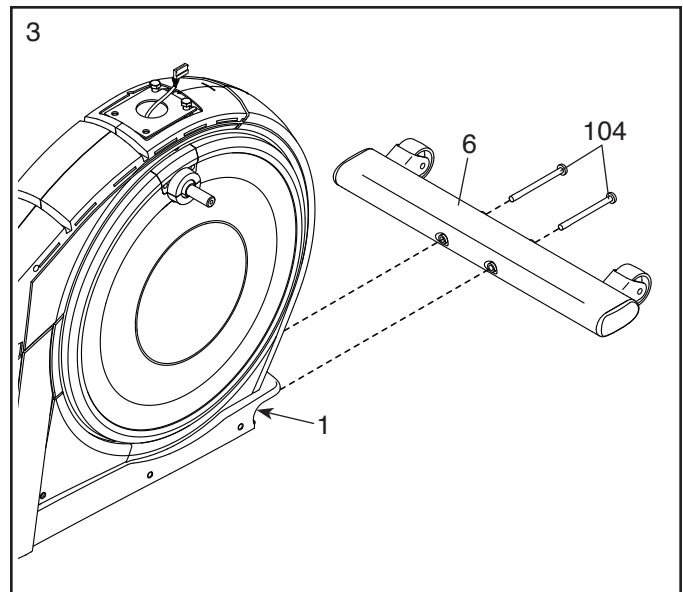

4. Using a plastic bag to keep your fingers clean, apply some of the included grease to the right Crank Arm (20).

Next, identify the Right Roller Arm (59), orient it as shown, and slide it onto the right Crank Arm (20).

Attach the Right Roller Arm (59) with an M8 x 20mm Screw (95) and a Crank Cover (77).

Repeat this step for the Left Roller Arm (45).

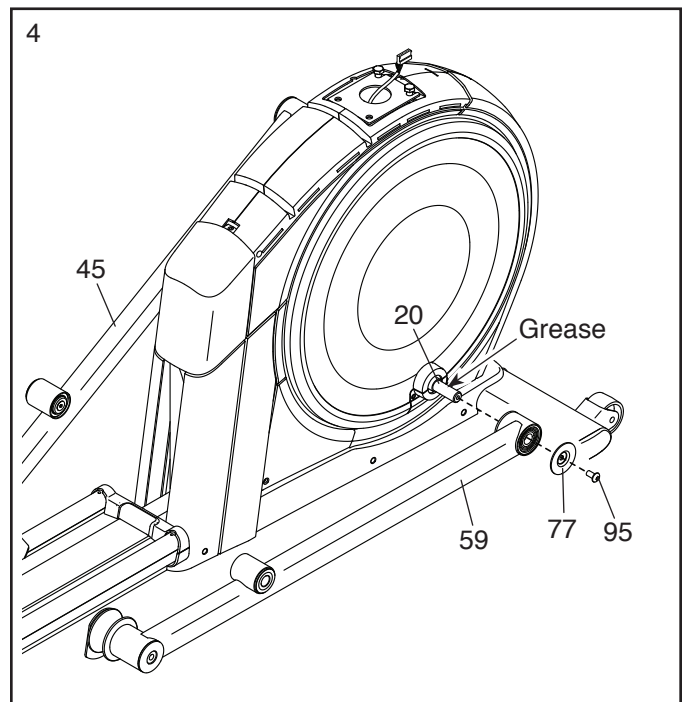

5. Orient the Upright (4) as shown. Have a second person hold the Upright near the Frame (1).

Next, locate the wire tie (A) in the lower end of the Upright (4). Tie the wire tie to the Main Wire (110) as shown. Then, pull the upper end of the wire tie until the Main Wire is routed through the Upright.

Tip: To prevent the Main Wire (110) from falling into the Upright (4), secure the Main Wire with the wire tie (A).

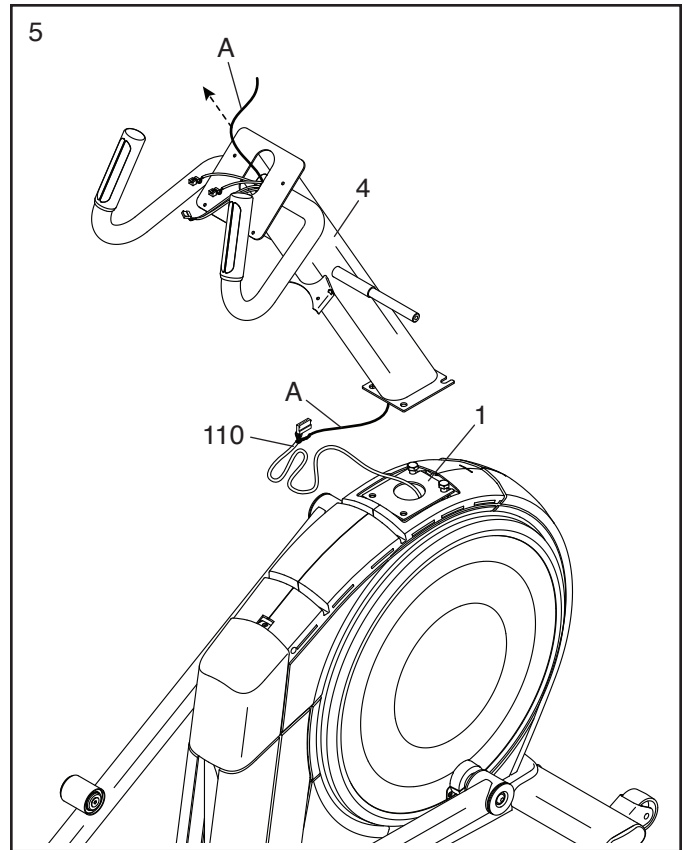

6. **Tip: Avoid pinching the Main Wire (110).** Have a second person hold the Upright (4) on the Frame (1).

Tip: Two M10 x 25mm Screws (92) are preattached to the Frame (1).

Attach the Upright (4) with two additional M10 x 25mm Screws (92); **do not fully tighten the Screws yet.**

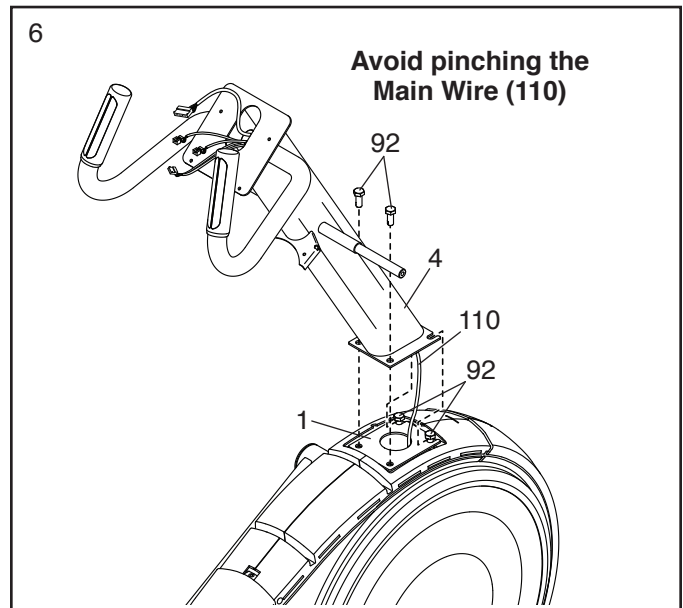

7. Apply grease to the axle on the right side of the Upright (4).

Next, slide a Pivot Spacer (54) onto the right side of the Upright (4).

Then, identify the Right Upper Body Leg (60), orient it as shown, and slide it onto the right side of the Upright (4).

Attach the Right Upper Body Leg (60) with an M8 x 13mm Screw (82) and an M8 x 28mm Washer (97).

Repeat this step for the Left Upper Body Leg (46).

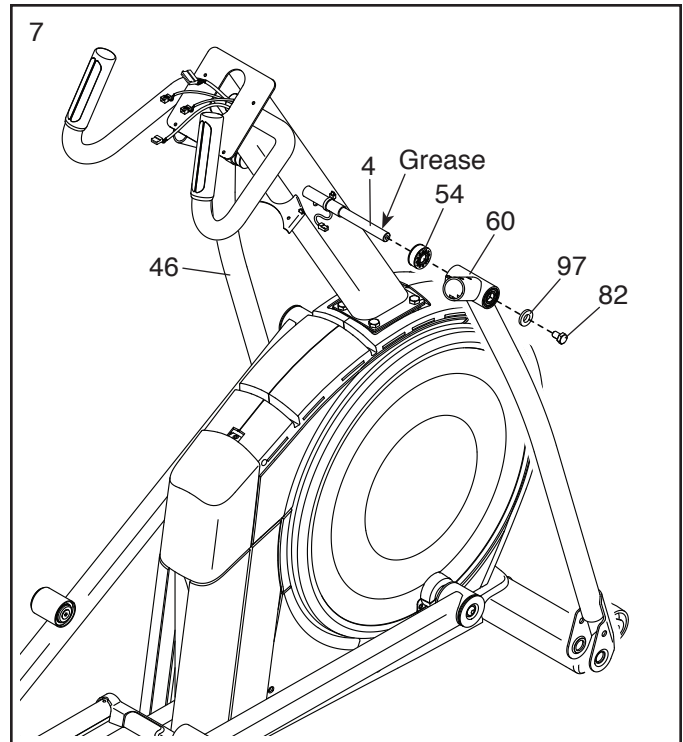

8. Orient the Right Pedal Arm (58) as shown, and apply grease to the axle.

Insert the Right Pedal Arm (58) into the Right Upper Body Leg (60) and into the Right Roller Arm (59).

Attach the Right Pedal Arm (58) to the Right Roller Arm (59) with an M8 x 20mm Flat Head Screw (120) and a Retainer (55); **make sure that the flat side (B) of the Retainer is facing the Right Roller Arm.**

Repeat this step for the Left Pedal Arm (44).

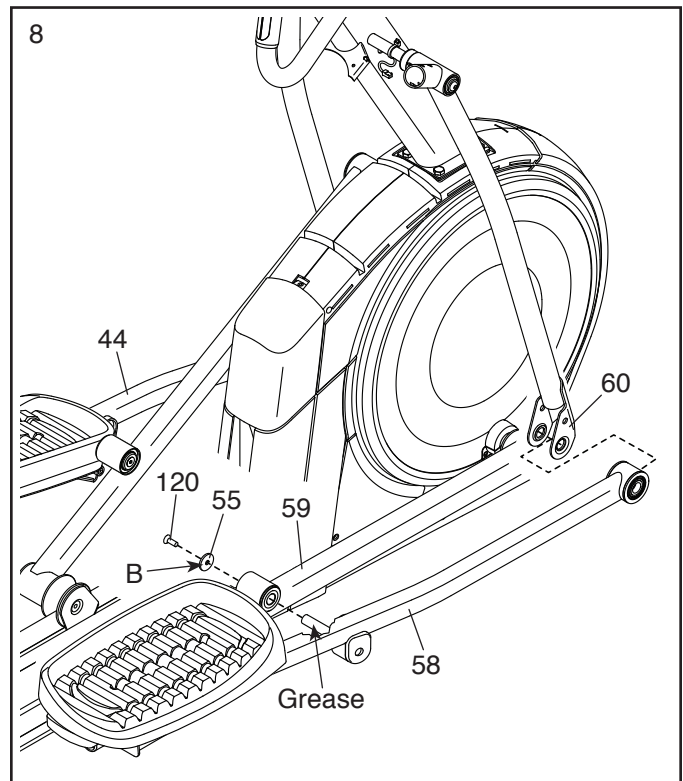

9. Apply grease to one of the Pedal Arm Axles (64).

Insert the Pedal Arm Axle (64) into the Right Upper Body Leg (60) and the Right Pedal Arm (58) from the direction shown.

Next, slide an M8 x 22mm Washer (129) onto an M8 x 13mm Screw (82), and tighten the Screw a few turns into the Pedal Arm Axle (64).

Then, tighten the Pedal Arm Axle (64) and the M8 x 13mm Screw (82) at the same time.

Repeat this step on the other side of the elliptical.

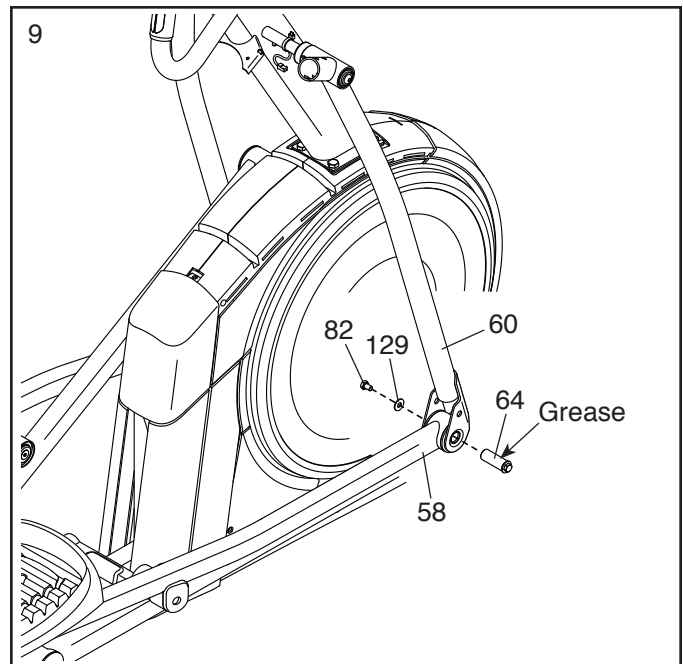

10. **See step 6.** Tighten the four M10 x 25mm Screws (92).

Untie and discard the wire tie on the Main Wire (110).

While a second person holds the Console (7) near the Upright (4), connect the wires on the Console to the Main Wire (110), to the Pulse Wire (63), and to the Extension Wires (111, 147).

Insert the excess wire into the Upright (4).

Tip: Avoid pinching the wires. Attach the Console (7) to the Upright (4) with four M4 x 16mm Screws (101); **start all the Screws, and then tighten them.**

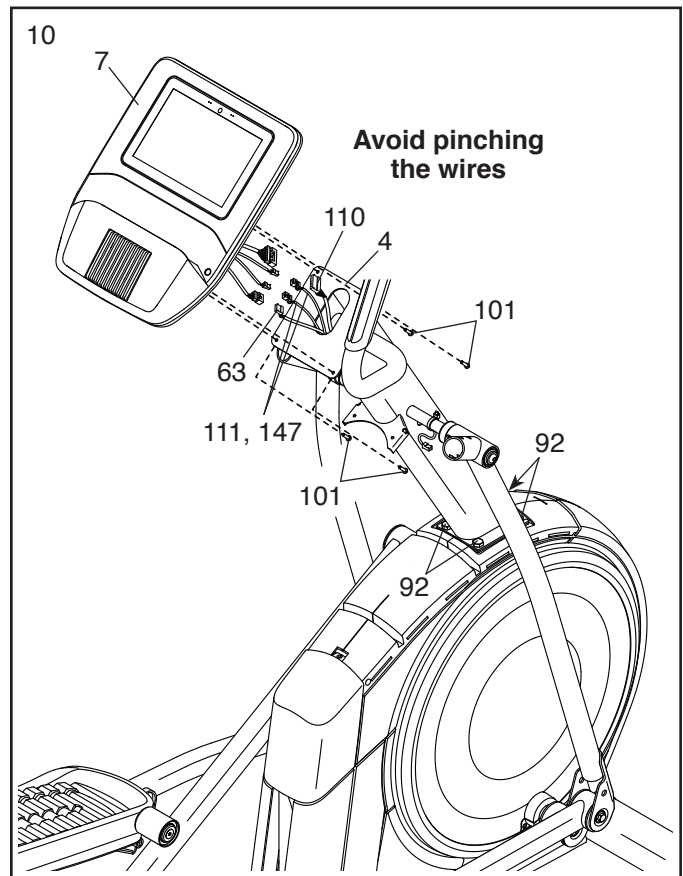

11. Orient the Rear Console Cover (80) as shown, and attach it to the Upright (4) with two M4 x 16mm Screws (101).

Then, orient the Front Console Cover (79) as shown, and attach it to the Rear Console Cover (80) with two M4 x 16mm Screws (101).

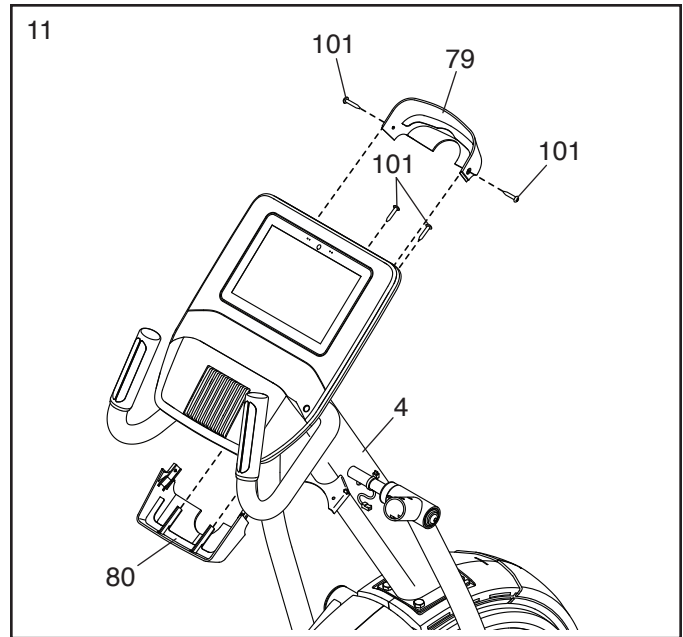

12. Orient the Accessory Tray (37) as shown, and attach it to the Upright (4) with two M4 x 16mm Screws (101).

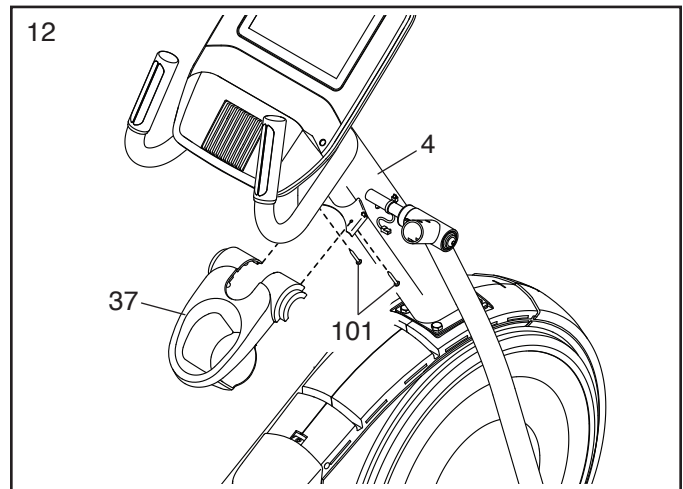

13. **Make sure that the Right Control Wire (C) is in the location shown.**

Orient a Lower Tray Cover (81) as shown, and hold it near the Right Control Wire (C). Then, **insert the Right Control Wire into the notches (D) in the Lower Tray Cover (see the inset drawing).**

Tip: Avoid pinching the Right Control Wire (C). Attach the Lower Tray Cover (81) to the right side of the Accessory Tray (37) with two M4 x 16mm Screws (101).

Repeat this step on the other side of the elliptical.

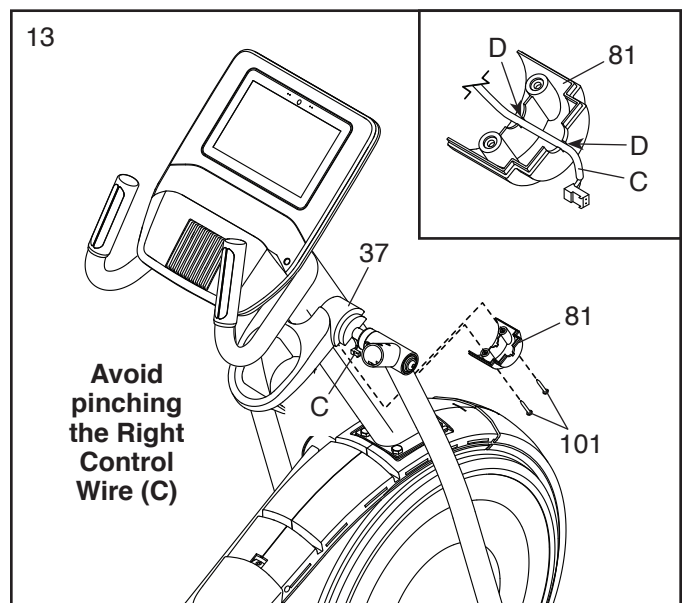

14. Identify the Right Upper Body Arm (61), orient it as shown, and hold it near the Right Upper Body Leg (60).

See the left inset drawing. Insert the Right Extension Wire (147) into the Right Upper Body Leg (60) and route it out of the indicated hole (E).

Tip: Avoid pinching the Right Extension Wire (147). Insert the Right Upper Body Arm (61) into the Right Upper Body Leg (60). Attach the Right Upper Body Arm with two M8 x 45mm Bolts (96) and two M8 Locknuts (102); **make sure that the Locknuts are in the hexagonal holes (F).**

See the right inset drawing. Connect the Right Extension Wire (147) to the Right Control Wire (C), and insert the excess wire into the Right Upper Body Arm (61). Next, orient the Wires exactly as shown, and attach a zip tie (148) around the Right Upper Body Leg (60) in the location shown. Then, cut off the excess zip tie.

Repeat this step for the Left Upper Body Arm (47).

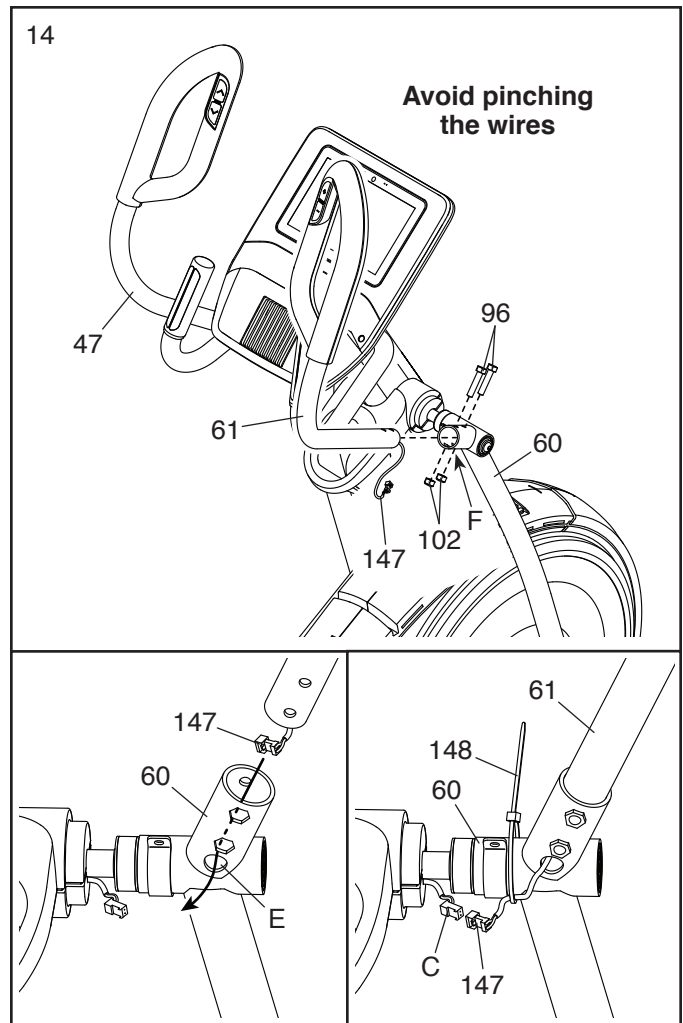

15. Orient the Front Shield Cover (117) and the Center Shield Cover (75) around the Upright (4) as shown. Attach them to each other with two M4 x 16mm Screws (101).

Tip: Avoid pinching the wires. Press the Front Shield Cover (117) and the Center Shield Cover (75) onto the Left and Right Shields (73, 74).

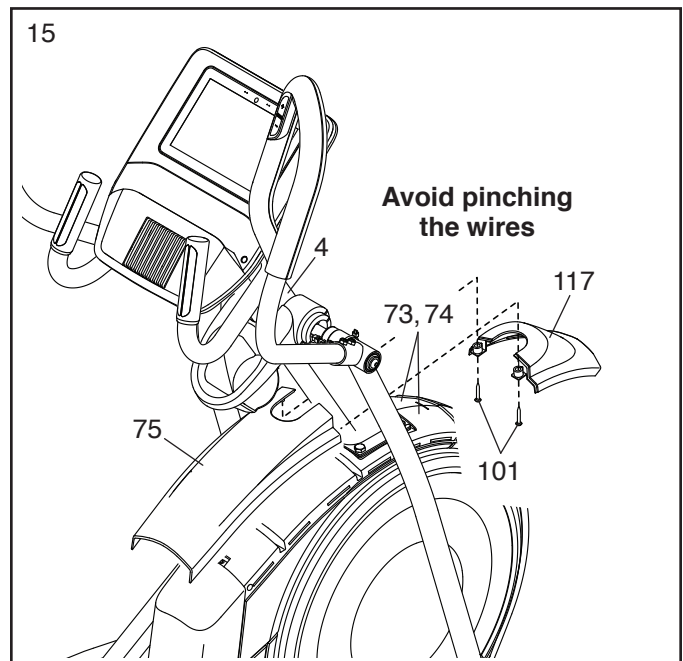

16. Identify the Right Leg Inner Cover (83), orient it as shown, and insert it through the Right Upper Body Leg (60).

Next, identify the Right Leg Outer Cover (69), orient it as shown, and press it onto the Right Leg Inner Cover (83).

Attach the Right Leg Outer and Inner Covers (69, 83) to each other with an M4 x 16mm Screw (101).

Repeat this step on the other side of the elliptical.

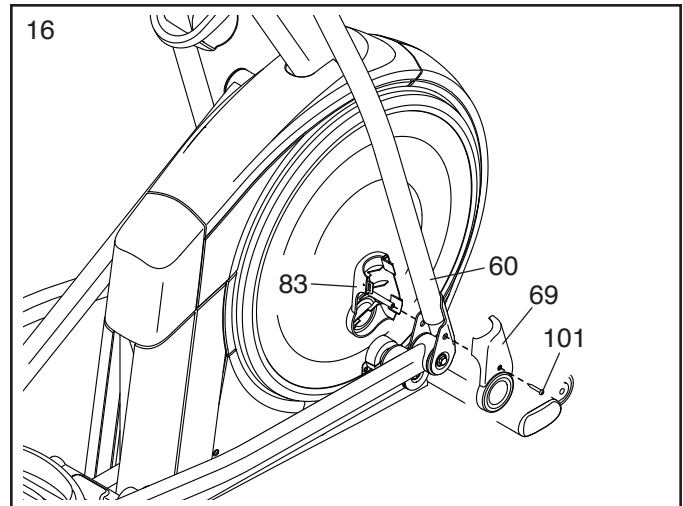

17. See the inset drawing. Make sure that the Right Control Wire (C) and the Right Extension Wire (147) are in the exact positions shown.

Tip: Avoid pinching the wires. Orient the Right Arm Front and Rear Covers (65, 66) around the Right Upper Body Leg (60) as shown, and attach them with two M4 x 16mm Screws (101). **Make sure to place the Extension Wire (147) in the indicated area (G) of the Right Rear Cover.**

Repeat this step on the other side of the elliptical.

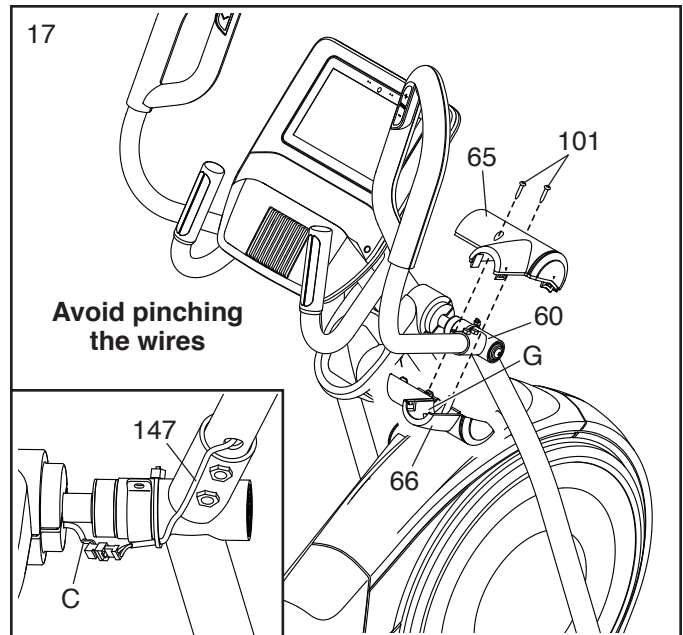

18. Attach the Tablet Holder (132) to the Console (7) with four Tablet Holder Screws (133); **start all the Tablet Holder Screws, and then tighten them.**

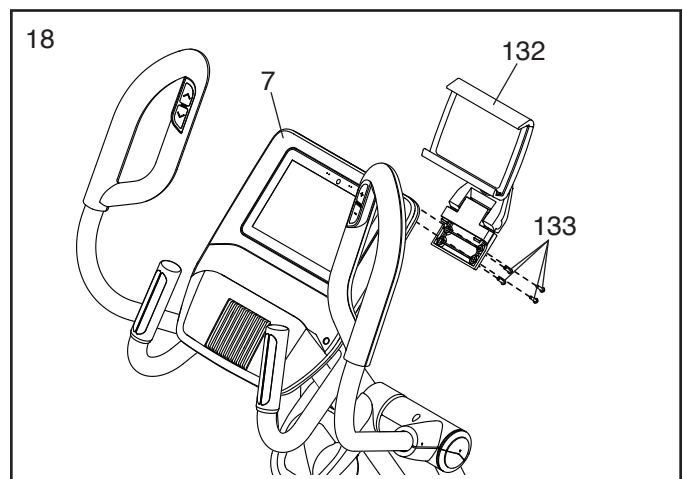

19. **Make sure that all parts are properly tightened.** Extra parts may be included. Place a mat beneath the elliptical to protect the floor.

THE CHEST HEART RATE MONITOR

HOW TO PUT ON THE HEART RATE MONITOR

If the heart rate monitor looks like the one shown in drawing 1, press the transmitter (A) onto the snap fasteners on the chest strap (B). If the heart rate monitor looks like the one shown in drawing 2, insert the tab (C) on one end of the chest strap (D) into one end of the transmitter (E). Then, press the end of the transmitter under the buckle (F) on the chest strap; the tab should be flush with the transmitter.

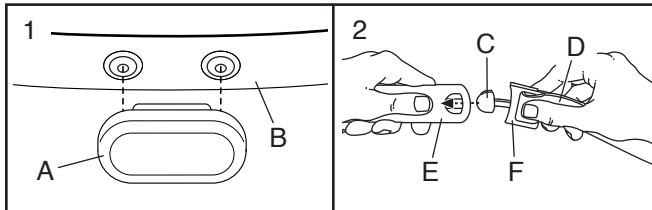

Next, wrap the heart rate monitor around your chest in the location shown; the heart rate monitor must be under your clothes, tight against your skin. Make sure that the logo is right-side-up. Then, attach the other end of the chest strap. Adjust the length of the chest strap, if necessary.

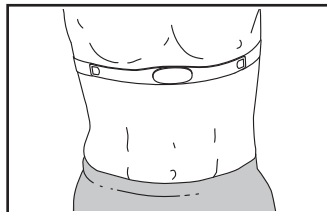

Next, pull the transmitter and the chest strap away from your body a few inches and locate the two electrode areas (G). Using saliva or contact lens solution, wet the electrode areas. Then, return the transmitter and the chest strap to a position against your chest.

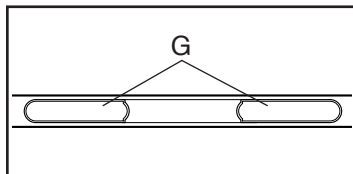

CARE AND MAINTENANCE

- Thoroughly dry the electrode areas with a soft towel after each use. Moisture may keep the heart rate monitor activated, shortening the life of the battery.
- Store the heart rate monitor in a warm, dry place. Do not store the heart rate monitor in a plastic bag or other container that may trap moisture.
- Do not expose the heart rate monitor to direct sunlight for extended periods of time, and do not expose it to temperatures above 122°F (50°C) or below 14°F (-10°C).
- Do not excessively bend or stretch the heart rate monitor when using or storing it.
- To clean the transmitter, use a damp cloth and a small amount of mild soap. Then, wipe the transmitter with a damp cloth and thoroughly dry it with a soft towel. Never use alcohol, abrasives, or chemicals to clean the transmitter. Hand wash and air dry the chest strap.

TROUBLESHOOTING

- If the heart rate monitor does not function when positioned as described at the left, move it slightly lower or higher on your chest.
- If heart rate readings are not displayed until you begin perspiring, re-wet the electrode areas.
- For the console to display heart rate readings, you must be within arm's length of the console.
- If there is a battery cover on the back of the transmitter, replace the battery with a new battery of the same type.
- The heart rate monitor is designed to work with people who have normal heart rhythms. Heart rate reading problems may be caused by medical conditions such as premature ventricular contractions (pvc's), tachycardia bursts, and arrhythmia.
- The operation of the heart rate monitor can be affected by magnetic interference from high power lines or other sources. If you suspect that magnetic interference is causing a problem, try relocating the fitness equipment.

HOW TO USE THE ELLIPTICAL

HOW TO PLUG IN THE POWER CORD

This product must be grounded. If it should malfunction or break down, grounding provides a path of least resistance for electric current to reduce the risk of electric shock. The power cord has a plug with a grounding pin.

⚠ DANGER: Improper connection of the power cord increases the risk of electric shock. Do not modify the plug—if it will not fit an outlet, have a proper outlet installed by a qualified electrician. If you are unsure whether the product is properly grounded, contact a qualified electrician.

Plug the power cord (A) into an appropriate outlet (B) that is properly installed and grounded in accordance with all local codes and ordinances. **The outlet must be on a nominal 120-volt circuit.**

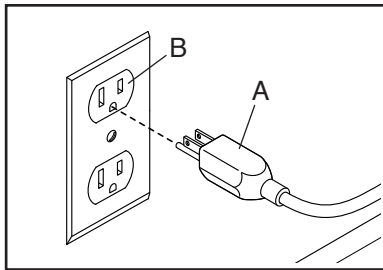

A temporary adapter (C) may be used to connect the power cord to a 2-pole receptacle (D) as shown at the right if a properly grounded outlet is not available.

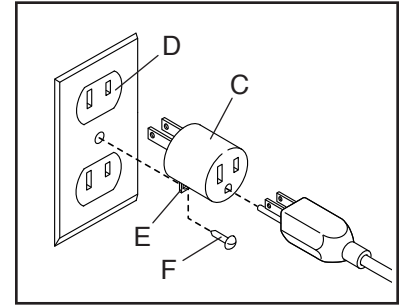

The lug (E) or wire extending from the adapter must be connected with a metal screw (F) to a permanent ground such as a properly grounded outlet box cover. **Some 2-pole receptacle outlet box covers are not grounded. Before using an adapter, contact a qualified electrician to determine whether the outlet box cover is grounded before using an adapter. The temporary adapter should be used only until a properly grounded outlet can be installed by a qualified electrician.**

HOW TO MOVE THE ELLIPTICAL

Due to the size and weight of the elliptical, moving it requires two persons. Stand in front of the elliptical, hold the upright (G), and place one foot against one of the wheels (H). Next, pull on the upright and have a second person lift the handle (I) until the elliptical will roll on the wheels. Carefully move the elliptical to the desired location, and then lower it to the floor.

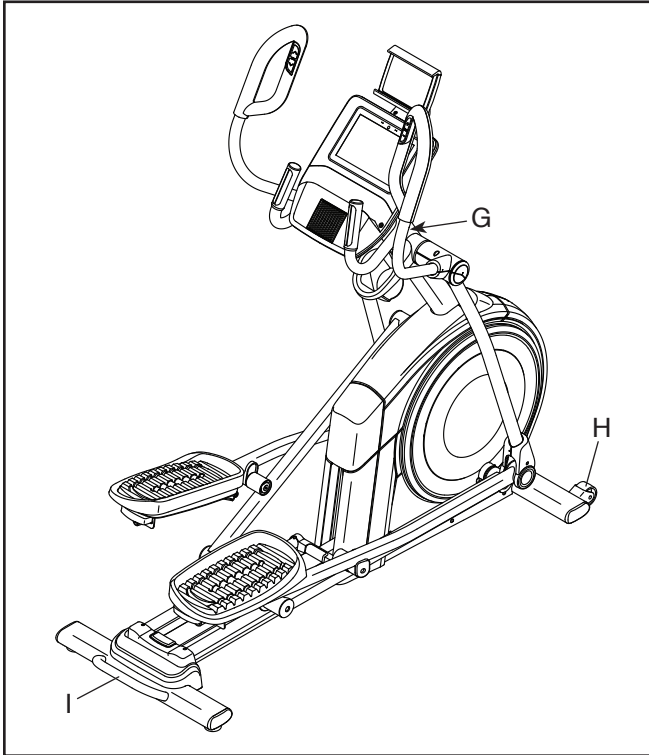

HOW TO LEVEL THE ELLIPTICAL

If the elliptical rocks slightly on your floor during use, turn one or both of the leveling feet (J) beneath the rear stabilizer or turn the leveling foot (K) under the center of the frame until the rocking motion is eliminated.

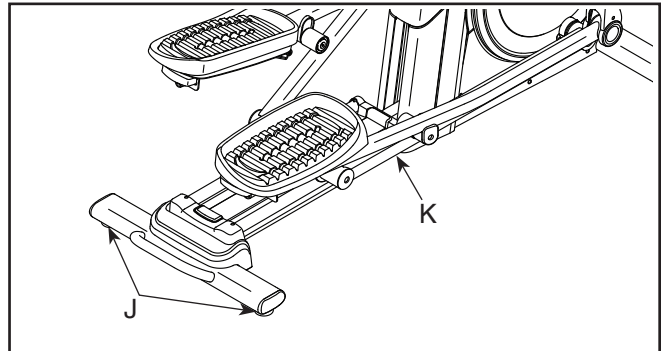

HOW TO USE THE TABLET HOLDER

IMPORTANT: The tablet holder (L) is designed for use with most full-size tablets. Do not place any other electronic device or object in the tablet holder.

To insert a tablet into the tablet holder (L), set the bottom edge of the tablet in the tray. Then, pull the clip over the top edge of the tablet. **Make sure that the tablet is firmly secured in the tablet holder.** If applicable to your tablet holder model, rotate and/or pivot the tablet holder to the desired position. Reverse these actions to remove the tablet from the tablet holder.

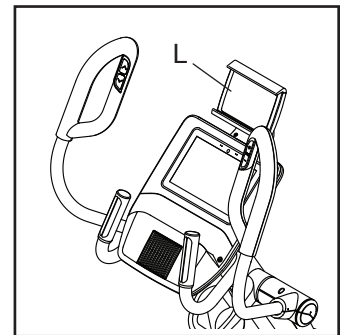

HOW TO ADJUST THE POSITIONS OF THE PEDALS

Each pedal can be adjusted to several positions. To adjust each pedal, simply pull the pedal handle (M) outward, move the pedal to the desired position, and then release the pedal handle into an adjustment hole beneath the pedal. Make sure to adjust both pedals to the same position.

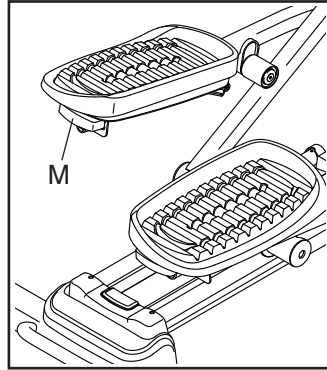

HOW TO EXERCISE ON THE ELLIPTICAL

See the drawing at the right. To mount the elliptical, hold the handlebars (N) or the upper body arms (O) and step onto the pedal (P) that is in the lower position. Then, step onto the other pedal. Push the pedals until they begin to move with a continuous motion. **Note:** **The pedals can turn in either direction. It is recommended that you turn the pedals in the direction shown by the arrow; however, for variety, you can turn the pedals in the opposite direction.**

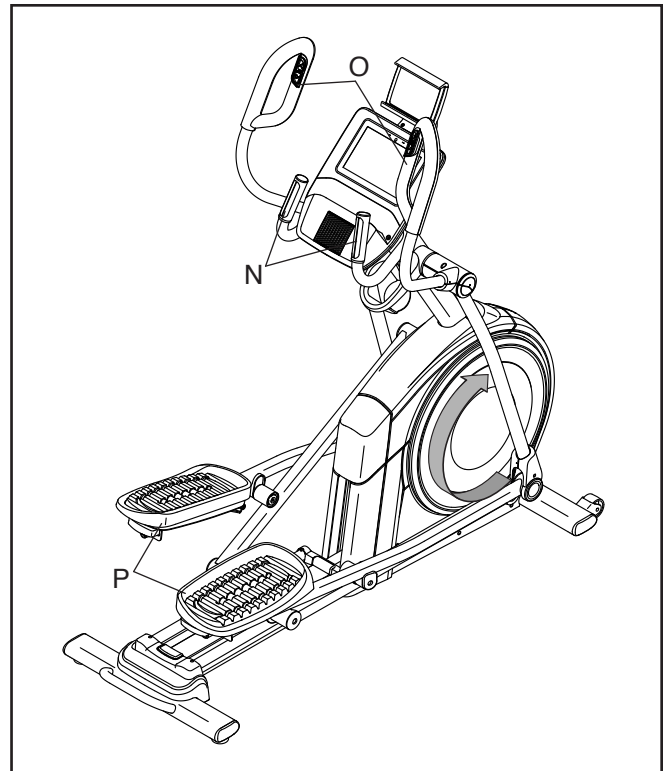

To dismount the elliptical, wait until the pedals (P) come to a complete stop. **Note: The elliptical does not have a free wheel; the pedals will continue to move until the flywheel stops.** When the pedals are stationary, step off the higher pedal first. Then, step off the lower pedal.

HOW TO USE THE CONSOLE

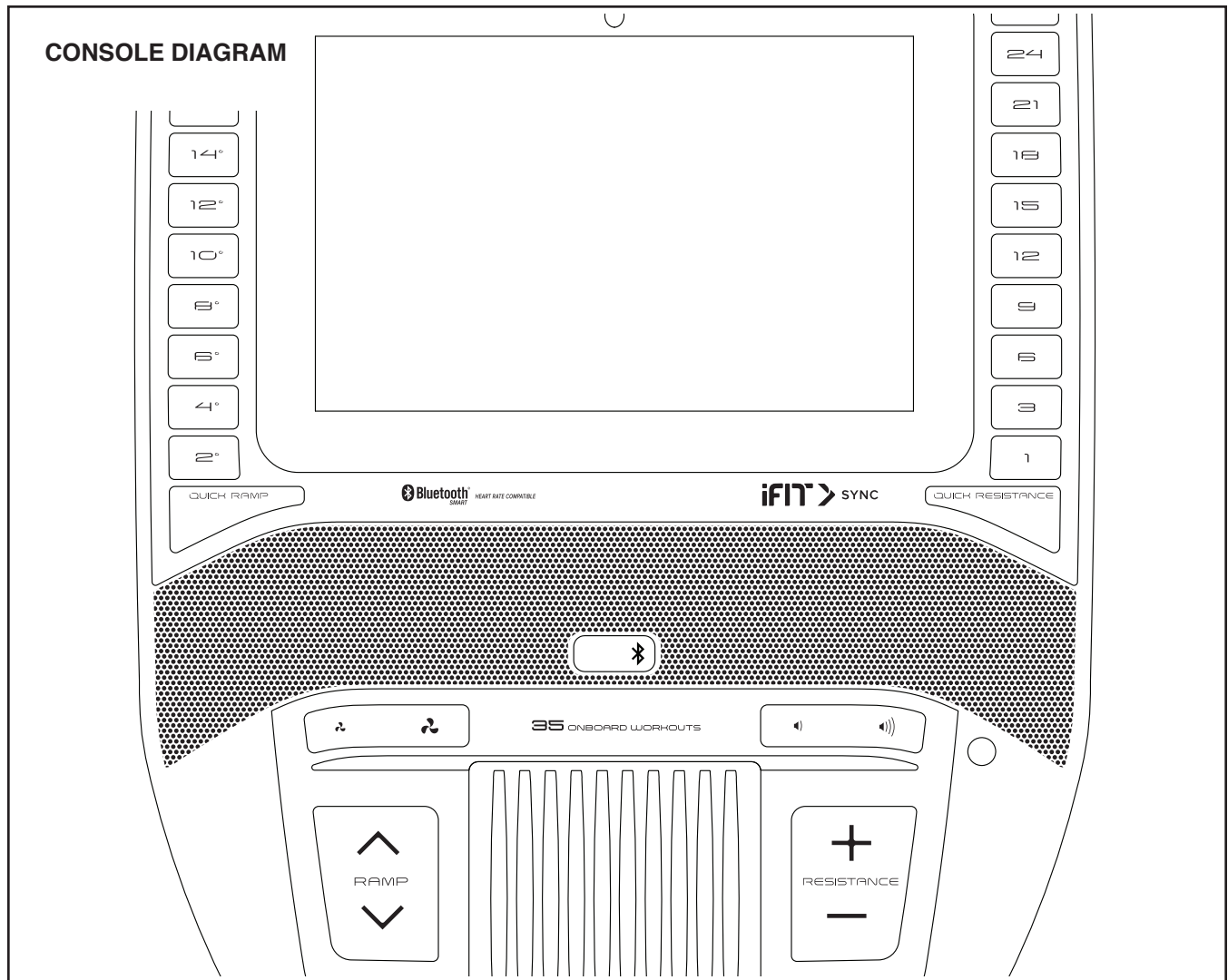

FEATURES OF THE CONSOLE

The advanced console offers an array of features designed to make your workouts more effective and enjoyable.

The console features wireless technology that enables the console to connect to iFit. With iFit, you can access a large and varied workout library, create your own workouts, track your workout results, and access many other features.

In addition, the console features a selection of onboard workouts. Each workout automatically controls the resistance of the pedals and the incline of the ramp as it guides you through an effective exercise session.

When you use the manual mode of the console, you can change the resistance of the pedals and the incline of the ramp with the touch of a button.

While you exercise, the console will display continuous exercise feedback. You can also measure your heart rate using the included chest heart rate monitor.

You can also listen to your favorite workout music or audio books with the console sound system while you exercise.

To turn on the power, see page 21. **To learn how to use the touch screen**, see page 21. **To set up the console**, see page 21.

HOW TO TURN ON THE POWER

IMPORTANT: If the elliptical has been exposed to cold temperatures, allow it to warm to room temperature before you turn on the power. If you do not do this, you may damage the console or other electrical components.

Plug in the power cord (see HOW TO PLUG IN THE POWER CORD on page 17). Next, locate the power switch on the frame near the power cord. Press the power switch to the reset position (A).

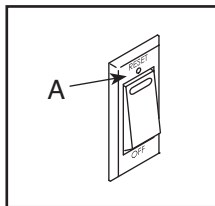

The console will then turn on and be ready for use.

Note: When you turn on the power for the first time, the incline system may calibrate automatically. The ramp will move upward and downward as it calibrates. When the ramp stops moving, the incline system is calibrated.

IMPORTANT: If the incline system does not calibrate automatically, see step 6 on page 21 and manually calibrate the incline system.

HOW TO USE THE TOUCH SCREEN

The console features a tablet with a full-color touch screen. The following information will help you use the touch screen:

- The console functions similarly to other tablets. You can slide or flick your finger against the screen to move certain images on the screen, such as the displays in a workout.
- To type information into a text box, first touch the text box to view the keyboard. To use numbers or other characters on the keyboard, touch *?123*. To view more characters, touch *~[<*. Touch *?123* again to return to the number keyboard. To return to the letter keyboard, touch *ABC*. To use a capital character, touch the shift button (upward-facing arrow symbol). To use multiple capital characters, touch the shift button again. To return to the lowercase keyboard, touch the shift button a third time. To clear the last character, touch the clear button (backward-facing arrow with an X symbol).

HOW TO SET UP THE CONSOLE

Before you use the elliptical for the first time, set up the console.

1. Connect to your wireless network.

To use iFit workouts and to use several other features of the console, the console must be connected to a wireless network. Follow the prompts on the screen to connect the console to your wireless network.

2. Customize settings.

Follow the prompts on the screen to set the desired unit of measurement and your time zone.

Note: To change these settings later, see HOW TO CHANGE CONSOLE SETTINGS on page 28.

3. Log into or create an iFit account.

Follow the prompts on the screen to log into your iFit account or to create an iFit account.

4. Tour the console.

The first time you use the console, a tour presentation will guide you through the features of the console.

5. Check for firmware updates.

First, touch the menu button (three horizontal lines symbol), touch *Settings*, touch *Maintenance*, and then touch *Update*. The console will check for firmware updates. For more information, see HOW TO CHANGE CONSOLE SETTINGS on page 28.

6. Calibrate the incline system.

First, touch the menu button (three horizontal lines symbol), touch *Settings*, touch *Maintenance*, and then touch *Calibrate Incline*. The ramp will rise and lower as it calibrates. For more information, see HOW TO CHANGE CONSOLE SETTINGS on page 28.

The console is now ready for you to begin working out. The following pages explain the workouts and other features that the console offers.

To use the manual mode, see page 22. **To use a featured workout or an onboard workout**, see page 24. **To create a draw-your-own-map workout**, see page 26. **To use an iFit workout**, see page 27.

To change console settings, see page 28. **To connect to a wireless network**, see page 29. **To use the sound system**, see page 30. **To make a Bluetooth® connection to the sound system**, see page 30. **To connect an HDMI cable**, see page 30.

Note: If there is a sheet of plastic on the screen, remove the plastic.

HOW TO USE THE MANUAL MODE

1. Touch the screen or press any button on the console to turn on the console.

See HOW TO TURN ON THE POWER on page 21. Note: It may take a few moments for the console to be ready for use.

2. Select the main menu.

When you turn on the console, the main menu will appear on the screen after the console boots up.

If you are in a workout, touch the screen and follow the prompts to end the workout and return to the main menu. If you are in the settings menus, touch the back button (arrow symbol) and then touch the close button (x symbol) to return to the main menu.

3. Change the resistance of the pedals and the incline of the ramp as desired.

Touch *Manual Start* and begin pedaling.

You can change the resistance of the pedals by pressing one of the numbered Quick Resistance buttons on the console, by pressing the Resistance increase and decrease buttons on the console, or by pressing the Resistance increase and decrease buttons on the right grip.

To vary the motion of the pedals, you can change the incline of the ramp by pressing one of the numbered Quick Ramp buttons on the console, by pressing the Ramp increase and decrease buttons on the console, or by pressing the Ramp increase and decrease buttons on the left grip.

Note: After you press a button, it will take a moment for the pedals to reach the selected resistance level or for the ramp to reach the selected incline level.

4. Follow your progress.

The console offers several display modes. The display mode that you select will determine which workout information is shown.

Drag upward on the screen to enter the fullscreen display mode. Drag downward on the screen to view the workout information displays.

Touch the various workout information displays to view more options. Touch the more button (+ symbol) to view statistics or charts. Touch the center of the screen to view even more display mode options.

If desired, adjust the volume level by pressing the volume increase and decrease buttons on the console.

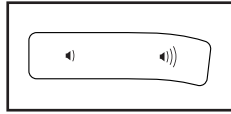

To pause the workout, simply touch the screen or stop pedaling. To continue the workout, simply resume pedaling.

To end the workout session, touch the screen to pause the workout, and then follow the prompts on the screen to end the workout and return to the main menu.

5. Measure your heart rate if desired.

You can measure your heart rate using either the handgrip heart rate monitor or the included chest heart rate monitor. Note: The console is compatible with all Bluetooth Smart heart rate monitors.

To use the chest heart rate monitor, see page 16. To use the handgrip heart rate monitor, follow the instructions below. **Note: If you use both heart rate monitors at the same time, the chest heart rate monitor will have priority.**

If there are sheets of plastic on the metal contacts (B) on the handgrip heart rate monitor, remove the plastic. To measure your heart rate, hold the handgrip heart rate monitor with your palms resting against the contacts. **Avoid moving your hands or gripping the contacts tightly.**

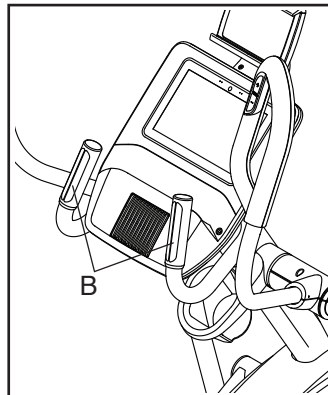

When your pulse is detected, your heart rate will be shown. For the most accurate heart rate reading, hold the contacts for at least 15 seconds.

If the display does not show your heart rate, make sure that your hands are positioned as described. Be careful not to move your hands excessively or to squeeze the contacts tightly. For optimal performance, clean the contacts using a soft cloth; **never use alcohol, abrasives, or chemicals to clean the contacts.**

6. Turn on the fan if desired.

The fan has several speed settings, including an auto mode. While the auto mode is selected, the speed of the fan will automatically increase or decrease as your pedaling speed increases or decreases. Press the fan increase and decrease buttons repeatedly to select a fan speed or to turn off the fan.

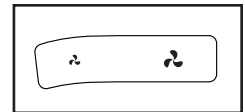

Note: If the pedals are not moved for a while when the main menu is selected, the fan will turn off automatically.

7. When you are finished exercising, unplug the power cord.

When you are finished exercising, press the power switch to the off position and unplug the power cord. **IMPORTANT: If you do not do this, the electrical components of the elliptical may wear prematurely.**

HOW TO USE A FEATURED WORKOUT OR AN ONBOARD WORKOUT

1. Touch the screen or press any button on the console to turn on the console.

See HOW TO TURN ON THE POWER on page 21. Note: It may take a few moments for the console to be ready for use.

2. Select the main menu or the workout library.

When you turn on the console, the main menu will appear on the screen after the console boots up.

If you are in a workout, touch the screen and follow the prompts to end the workout and return to the main menu. If you are in the settings menus, touch the back button (arrow symbol) and then touch the close button (x symbol) to return to the main menu.

Touch the buttons at the bottom of the screen to select either the main menu (Home button) or the workout library (Browse button).

3. Select a workout.

To select a workout from the main menu or the workout library, simply touch the desired workout button on the screen. Slide or flick the screen to scroll upward or downward if necessary.

Note: To use a featured workout, the console must be connected to a wireless network (see HOW TO CONNECT TO A WIRELESS NETWORK on page 29).

The featured workouts on your console will change periodically. To save one of the featured workouts for future use, you can add it as a favorite by touching the favorites button (heart symbol). You must be logged into your iFit account to save a featured workout (see step 3 on page 27).

To draw your own map for a workout, see HOW TO CREATE A DRAW-YOUR-OWN-MAP WORKOUT on page 26.

When you select a workout, the screen will show an overview of the workout that includes details such as the duration and distance of the workout and the approximate number of calories you will burn during the workout.

4. Start the workout.

Touch *Start Workout* to start the workout.

The workout will function in the same way as the manual mode (see page 22).

During some workouts, the screen will show a map of the route and a marker indicating your progress. Touch the buttons on the screen to select the desired map options.

During some workouts, the screen may show a target speed. As you exercise, keep your pedaling speed near the target speed shown on the screen. A message may appear prompting you to increase, decrease, or maintain your pedaling speed.

During some workouts, the screen may show a target speed. As you exercise, keep your pedaling speed near the target speed shown on the screen. A message may appear prompting you to increase, decrease, or maintain your pedaling speed.

IMPORTANT: The target speed is intended only to provide motivation. Your actual pedaling speed may be slower than the target speed. Make sure to pedal at a speed that is comfortable for you.

If the resistance level and/or incline level is too high or too low, you can manually override the setting by pressing the Resistance buttons or the Ramp buttons. **If you press a Resistance button**, you can then manually control the resistance level (see step 3 on page 22). **If you press a Ramp button**, you can then manually control the incline level (see step 3 on page 22). **To return to the programmed resistance and/or incline settings of the workout**, touch *Follow Workout*.

Note: The calorie goal shown in the workout description is an estimate of the number of calories that you will burn during the workout. The actual number of calories that you burn will depend on various factors, such as your weight. In addition, if you manually change the resistance level or incline level of the ramp during the workout, the number of calories you burn will be affected.

To pause the workout, simply touch the screen or stop pedaling. To continue the workout, simply resume pedaling.

To end the workout, touch the screen to pause the workout, and then follow the prompts on the screen to end the workout and return to the main menu.

When the workout ends, a workout summary will appear on the screen. If desired, you can select options such as adding the workout to your schedule (see HOW TO USE AN IFIT WORKOUT on page 27) or adding the workout to your favorites list. Then, touch *Save Workout* to return to the main menu.

5. Follow your progress.

See step 4 on page 22.

6. Measure your heart rate if desired.

See step 5 on page 23.

7. Turn on the fan if desired.

See step 6 on page 23.

8. When you are finished exercising, unplug the power cord.

See step 7 on page 23.

HOW TO CREATE A DRAW-YOUR-OWN-MAP WORKOUT

1. Touch the screen or press any button on the console to turn on the console.

See HOW TO TURN ON THE POWER on page 21. Note: It may take a few moments for the console to be ready for use.

2. Select a draw-your-own-map workout.

When you turn on the console, the main menu will appear on the screen after the console boots up.

If you are in a workout, touch the screen and follow the prompts to end the workout and return to the main menu. If you are in the settings menus, touch the back button (arrow symbol) and then touch the close button (x symbol) to return to the main menu.

To select a draw-your-own-map workout, touch the Create button at the bottom of the screen.

3. Draw your map.

Navigate to the area on the map where you want to draw your workout by typing in the search box or by sliding your fingers on the screen. Touch the screen to add the start point for your workout. Then, touch the screen to add the end point for your workout.

If you want to start and end your workout at the same point, touch *Close Loop* or *Out & Back* in the map options. You can also select whether you want your workout to snap to the road.

If you make a mistake, touch *Undo* in the map options.

The screen will display the elevation and distance statistics for your workout.

4. Save your workout.

Touch *Save New Workout* to save your workout. If desired, enter a title and description for your workout. Then, touch the continue button (> symbol).

5. Start the workout.

Touch *Start Workout* to start the workout. The workout will function in the same way as a featured workout or an onboard workout (see page 24).

6. Follow your progress.

See step 4 on page 24.

7. Measure your heart rate if desired.

See step 5 on page 23.

8. Turn on the fan if desired.

See step 6 on page 23.

9. When you are finished exercising, unplug the power cord.

See step 7 on page 23.

HOW TO USE AN iFIT WORKOUT

To use an iFit workout, the console must be connected to a wireless network (see HOW TO CONNECT TO A WIRELESS NETWORK on page 29). An iFit account is also required.

1. Add workouts to your schedule on iFit.com.

On your computer, smartphone, tablet, or other device, open an internet browser, go to iFit.com, and log in to your iFit account.

Next, navigate to Menu > Library on the website. Browse the workout programs in the library and join the desired workouts.

Then, navigate to Menu > Schedule to view your schedule. All of the workouts that you have joined will appear on your schedule; you can arrange or delete the workouts on your schedule as desired.

Take time to explore the iFit.com website before you log out.

2. Select the main menu.

When you turn on the console, the main menu will appear on the screen after the console boots up.

If you are in a workout, touch the screen and follow the prompts to end the workout and return to the main menu. If you are in the settings menus, touch the back button (arrow symbol) and then touch the close button (x symbol) to return to the main menu.

3. Log in to your iFit account.

If you have not already done so, touch the menu button (three horizontal lines symbol) on the screen and then touch *Log in* to log in to your iFit account. Follow the prompts on the screen to enter your username and password.

To switch users within your iFit account, touch the menu button, touch *Settings*, and then touch *Manage Accounts*. If more than one user is associated with the account, a list of users will appear. Touch the name of the desired user.

4. Select an iFit workout that you have previously added to your schedule on iFit.com.

IMPORTANT: Before iFit workouts will load, you must add them to your schedule on iFit.com (see step 1).

To load an iFit workout from iFit.com to the console, touch the calendar button (calendar symbol) at the bottom of the screen.

When you load a workout, the screen will show an overview of the workout that includes details such as the duration and distance of the workout and the approximate number of calories you will burn during the workout.

5. Start the workout.

Touch *Start Workout* to start the workout. The workout will function in the same way as a featured workout or an onboard workout (see page 24).

6. Follow your progress.

See step 4 on page 22.

7. Measure your heart rate if desired.

See step 5 on page 23.

8. Turn on the fan if desired.

See step 6 on page 23.

9. When you are finished exercising, unplug the power cord.

See step 7 on page 23.

For more information about iFit, go to iFit.com.

HOW TO CHANGE CONSOLE SETTINGS

IMPORTANT: Some of the settings and features described may not be enabled. Occasionally, a firmware update may cause your console to function slightly differently.

1. Select the settings main menu.

First, turn on the power (see HOW TO TURN ON THE POWER on page 21). Note: It may take a few moments for the console to be ready for use.

Next, select the main menu (Home button). When you turn on the console, the main menu will appear on the screen after the console boots up. If you are in a workout, touch the screen and follow the prompts to end the workout and return to the main menu. If you are in the settings menus, touch the back button (arrow symbol) and then touch the close button (x symbol) to return to the main menu.

Then, touch the menu button (three horizontal lines symbol) on the screen, and then touch *Settings*. The settings menu will appear on the screen.

2. Navigate the settings menus and change settings as desired.

Slide or flick the screen to scroll upward or downward if necessary. To view a settings menu, simply touch the menu name. To exit a menu, touch the back button (arrow symbol). You may be able to view and change settings in the following settings menus:

Account

- My Profile
- In Workout
- Manage Accounts

Equipment

- Equipment Info
- Equipment Settings
- Maintenance
- Wi-Fi

About

- Legal

3. Customize the unit of measurement and other settings.

To customize the unit of measurement, the time zone, or other settings, touch *Equipment Info* or *Equipment Settings*, and then touch the desired settings.

The console can display speed and distance in either standard or metric units of measurement.

4. View machine information or console app information.

Touch *Equipment Info*, and then touch *Machine Info* or *App Info* to view information about your elliptical or about the console app.

5. Update the console firmware.

For the best results, regularly check for firmware updates. Touch *Maintenance*, and then touch *Update* to check for firmware updates using your wireless network. The update will begin automatically. **IMPORTANT: To avoid damaging the elliptical, do not turn off the power while the firmware is being updated.**

The screen will show the progress of the update. When the update is complete, the elliptical will turn off and then turn back on. If it does not, press the power switch into the off position. Wait for several seconds, and then press the power switch into the reset position. Note: It may take a few minutes for the console to be ready for use.

Note: Occasionally, a firmware update may cause the console to function slightly differently. These updates are always designed to improve your exercise experience.

6. Calibrate the incline system.

To calibrate the incline system, touch *Maintenance*, touch *Calibrate Incline*, and then touch *Begin*. The ramp will automatically rise to the maximum incline level, lower to the minimum incline level, and then return to the starting position. This will calibrate the incline system. When the incline system is calibrated, touch *Finish*.

IMPORTANT: Keep pets, feet, and other objects away from the elliptical while the incline system is calibrating.

7. Exit the settings main menu.

If you are in a settings menu, touch the back button. Then, touch the close button (x symbol) to exit the settings main menu.

HOW TO CONNECT TO A WIRELESS NETWORK

To use iFit workouts and to use several other features of the console, the console must be connected to a wireless network.

1. Select the main menu.

First, turn on the power (see HOW TO TURN ON THE POWER on page 21). Note: It may take a few moments for the console to be ready for use.

Next, select the main menu (Home button). When you turn on the console, the main menu will appear on the screen after the console boots up. If you are in a workout, touch the screen and follow the prompts to end the workout and return to the main menu. If you are in the settings menus, touch the back button (arrow symbol) and then touch the close button (x symbol) to return to the main menu.

2. Select the wireless network menu.

Touch the menu button (three horizontal lines symbol), and then touch *Wi-Fi* to select the wireless network menu.

3. Enable Wi-Fi.

Make sure that Wi-Fi® is enabled. If it is not enabled, touch the *Wi-Fi* toggle to enable it.

4. Set up and manage a wireless network connection.

When Wi-Fi is enabled, the screen will show a list of available networks. Note: It may take a few moments for the list of wireless networks to appear.

Note: You must have your own wireless network and an 802.11b/g/n router with SSID broadcast enabled (hidden networks are not supported).

When a list of networks appears, touch the desired network. Note: You will need to know your network name (SSID). If your network has a password, you will also need to know the password.

Follow the prompts on the screen to enter your password and connect to the selected wireless network. (To use the keyboard, see HOW TO USE THE TOUCH SCREEN on page 21.)

When the console is connected to your wireless network, a checkmark will appear next to the wireless network name.

If you are having problems connecting to an encrypted network, make sure that your password is correct. Note: Passwords are case-sensitive.

Note: The console supports unsecured and secured (WEP, WPA™, and WPA2™) encryption. A broadband connection is recommended; performance depends on connection speed.

Note: If you have questions after following these instructions, go to support.iFit.com for assistance.

5. Exit the wireless network menu.

To exit the wireless network menu, touch the back button (arrow symbol).

HOW TO USE THE SOUND SYSTEM

To play music or audio books through the console sound system while you exercise, plug a 3.5 mm male to 3.5 mm male audio cable (not included) into the jack on the console and into a jack on your personal audio player; **make sure that the audio cable is fully plugged in. Note: To purchase an audio cable, see your local electronics store.**

Next, press the play button on your personal audio player. Adjust the volume level using the volume increase and decrease buttons on the console or the volume control on your personal audio player.

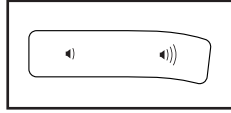

HOW TO MAKE A BLUETOOTH CONNECTION TO THE SOUND SYSTEM

1. **Place or hold your Bluetooth-compatible device near the console.**
2. **Enable the Bluetooth setting on your device.**
3. **Pair your device to the console.**

Press and hold the Bluetooth button on the console for 3 seconds. The console will enter pairing mode. When your device and the console pair successfully, the audio from your device will play through the console sound system.

Note: The console can save 8 devices in its memory. If you have previously paired your device to the console, you can simply press the Bluetooth button to connect your device to the console.

4. **Erase the console device memory if necessary.**

If you need to erase all the Bluetooth-compatible devices saved in the console memory, press and hold the Bluetooth button for 10 seconds.

HOW TO CONNECT AN HDMI CABLE

To show your console screen on a TV or monitor, plug an HDMI cable (not included) into the port on the console and into a port on your TV or monitor; **make sure that the HDMI cable is fully plugged in. Note: To purchase an HDMI cable, see your local electronics store.**

FCC INFORMATION

This equipment has been tested and found to comply with the limits for a Class B digital device, pursuant to part 15 of the FCC Rules. These limits are designed to provide reasonable protection against harmful interference in a residential installation. This equipment generates, uses, and can radiate radio frequency energy and, if not installed and used in accordance with the instructions, may cause harmful interference to radio communications. However, there is no guarantee that interference will not occur in a particular installation. If this equipment does cause harmful interference to radio or television reception, which can be determined by turning the equipment off and on, try to correct the interference by one or more of the following measures:

- Reorient or relocate the receiving antenna.
- Increase the separation between the equipment and the receiver.
- Connect the equipment into an outlet on a circuit different from that to which the receiver is connected.
- Consult the dealer or an experienced radio/TV technician for help.

FCC CAUTION: To assure continued compliance, use only shielded interface cables when connecting to computer or peripheral devices. Changes or modifications not expressly approved by the party responsible for compliance could void the user's authority to operate this equipment.

IMPORTANT: To satisfy exposure compliance requirements, the antenna and transmitter in the console must be at least 8 in. (20 cm) from all persons and must not be near or connected to any other antenna or transmitter.

Note: The console contains FCC ID: SMFOMC351834.

MAINTENANCE AND TROUBLESHOOTING

MAINTENANCE

Regular maintenance is important for optimal performance and to reduce wear. Inspect and properly tighten all parts each time the elliptical is used. Replace any worn parts immediately.

To clean the elliptical, use a damp cloth and a small amount of mild soap. **IMPORTANT: To avoid damage to the console, keep liquids away from the console and keep the console out of direct sunlight.**

CONSOLE TROUBLESHOOTING

If the console does not turn on, make sure that the power cord is fully plugged in and that the power switch is in the reset position. If there are exterior wires on the console, make sure that the connectors on the wires are oriented correctly and are connected firmly.

If the console does not display your heart rate when you hold the handgrip heart rate monitor, or if the displayed heart rate appears to be too high or too low, see step 5 on page 23.

If the console does not display your heart rate when you use the chest heart rate monitor, see TROUBLESHOOTING on page 16.

If you are having problems connecting the console to a wireless network or if you are having problems with your iFit account or iFit workouts, go to support.iFit.com.

If the console does not boot up properly, or if the console freezes and does not respond, reset the console to the factory default settings. **IMPORTANT: Doing**

this will erase all custom settings you have made to the console. Resetting the console requires two

people. First, press the power switch and unplug the power cord. Next, locate the small reset opening (A) on the back or the side of the console. Using a bent paper clip, press and hold the reset button inside the opening, and have a second person plug in the power cord and press the power switch. Continue holding the reset button until the console turns on. When the reset operation is complete, the console will turn off and then turn back on. If it does not, press the power switch off and then on again. Once the console turns on, check for firmware updates (see step 5 on page 28). Note: It may take a few minutes for the console to be ready for use.

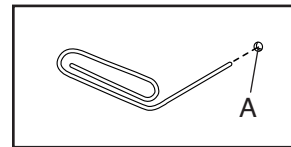

TABLET HOLDER TROUBLESHOOTING

If the tablet holder does not stay in place, rotate the tablet holder backward and tighten the screw (B) until the tablet holder stays in place when it is rotated to the desired position.

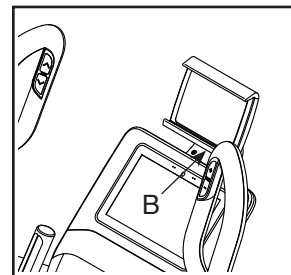

INCLINE SYSTEM TROUBLESHOOTING

If the ramp does not move to the correct incline level, see step HOW TO CHANGE CONSOLE SETTINGS on page 28 and calibrate the incline system.

HOW TO ADJUST THE REED SWITCH

If the console does not display correct feedback, the reed switch should be adjusted. To adjust the reed switch, first **press the power switch to the off position and unplug the power cord.**

Next, using a standard screwdriver, carefully pry off the left Disc (71).

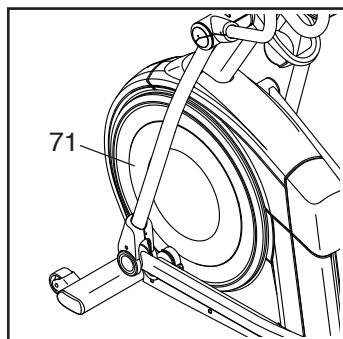

Then, locate the Reed Switch (38). Turn the Pulley (19) until a Magnet (43) is aligned with the Reed Switch.

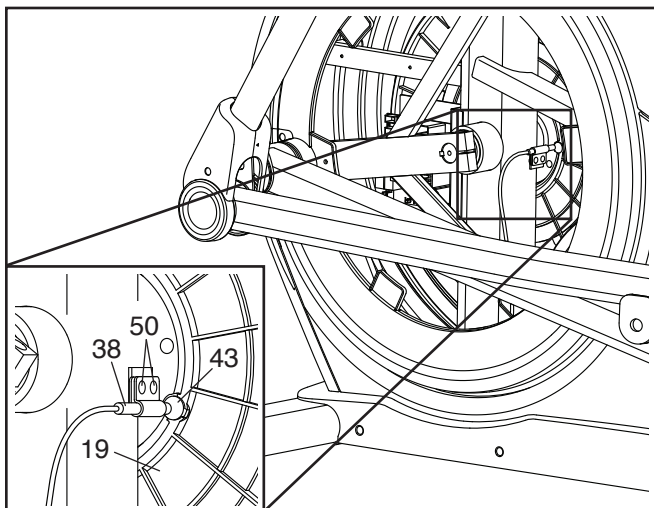

Next, slightly loosen the indicated two M4 x 12mm Self-tapping Screws (50). Slide the Reed Switch (38) slightly closer to or away from the Magnet (43), and then retighten the Self-tapping Screws.

Then, plug in the power cord, press the power switch, and rock the Pulley (19) forward and backward just enough that the Magnet (43) passes the Reed Switch (38) repeatedly. Repeat these actions until the console displays correct feedback.

When the reed switch is correctly adjusted, reattach the left disc, plug in the power cord, and press the power switch.

HOW TO ADJUST THE DRIVE BELT

If the pedals slip while you are pedaling, even while the resistance is adjusted to the highest level, the drive belt may need to be adjusted. To adjust the drive belt, first **press the power switch to the off position and unplug the power cord.**

Next, locate the Access Cover (3) on the Right Shield (74). Remove the M4 x 16mm Screw (101) and then remove the Access Cover.

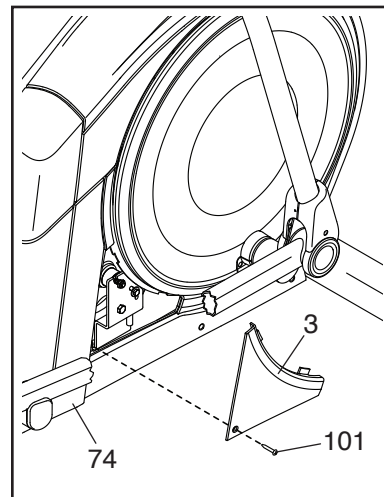

Next, locate and loosen the Idler Screw (89). Tighten the Drive Belt Adjustment Screw (91) until the Drive Belt (113) is tight. Then, retighten the Idler Screw.

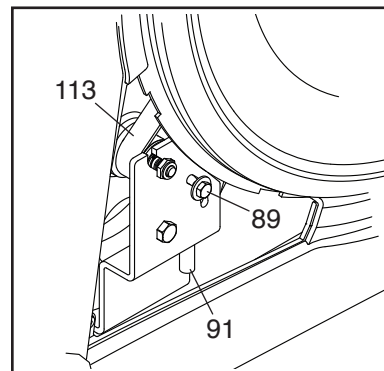

Reattach the parts that you removed. Then, plug in the power cord and press the power switch.

EXERCISE GUIDELINES

⚠️ WARNING: Before beginning this or any exercise program, consult your physician. This is especially important for persons over age 35 or persons with pre-existing health problems.

The heart rate monitor is not a medical device. Various factors may affect the accuracy of heart rate readings. The heart rate monitor is intended only as an exercise aid in determining heart rate trends in general.

These guidelines will help you to plan your exercise program. For detailed exercise information, obtain a reputable book or consult your physician. Remember, proper nutrition and adequate rest are essential for successful results.

EXERCISE INTENSITY

Whether your goal is to burn fat or to strengthen your cardiovascular system, exercising at the proper intensity is the key to achieving results. You can use your heart rate as a guide to find the proper intensity level. The chart below shows recommended heart rates for fat burning and aerobic exercise.

165	155	145	140	130	125	115	❤️
145	138	130	125	118	110	103	❤️
125	120	115	110	105	95	90	❤️
<hr/>							
20	30	40	50	60	70	80	

To find the proper intensity level, find your age at the bottom of the chart (ages are rounded off to the nearest ten years). The three numbers listed above your age define your “training zone.” The lowest number is the heart rate for fat burning, the middle number is the heart rate for maximum fat burning, and the highest number is the heart rate for aerobic exercise.

Burning Fat—To burn fat effectively, you must exercise at a low intensity level for a sustained period of time. During the first few minutes of exercise, your body uses carbohydrate calories for energy. Only after the first few minutes of exercise does your body begin to use stored fat calories for energy. If your goal is to burn fat, adjust the intensity of your exercise until your heart rate is near the lowest number in your training zone. For maximum fat burning, exercise with your heart rate near the middle number in your training zone.

Aerobic Exercise—If your goal is to strengthen your cardiovascular system, you must perform aerobic exercise, which is activity that requires large amounts of oxygen for prolonged periods of time. For aerobic exercise, adjust the intensity of your exercise until your heart rate is near the highest number in your training zone.

WORKOUT GUIDELINES

Warming Up—Start with 5 to 10 minutes of stretching and light exercise. A warm-up increases your body temperature, heart rate, and circulation in preparation for exercise.

Training Zone Exercise—Exercise for 20 to 30 minutes with your heart rate in your training zone. (During the first few weeks of your exercise program, do not keep your heart rate in your training zone for longer than 20 minutes.) Breathe regularly and deeply as you exercise; never hold your breath.

Cooling Down—Finish with 5 to 10 minutes of stretching. Stretching increases the flexibility of your muscles and helps to prevent post-exercise problems.

EXERCISE FREQUENCY

To maintain or improve your condition, complete three workouts each week, with at least one day of rest between workouts. After a few months of regular exercise, you may complete up to five workouts each week, if desired. Remember, the key to success is to make exercise a regular and enjoyable part of your everyday life.

PART LIST

Model No. NTEL71418.5 R1219A

Key No.	Qty.	Description	Key No.	Qty.	Description
1	1	Frame/Ramp	51	2	Roller
2	1	Rear Stabilizer	52	1	Left Pedal Handle
3	1	Access Cover	53	2	Axle Cover
4	1	Upright	54	2	Pivot Spacer
5	6	M4 x 19mm Screw	55	2	Retainer
6	1	Front Stabilizer	56	4	Roller Arm Bushing
7	1	Console	57	6	Large Arm Bearing
8	2	Roller Guide	58	1	Right Pedal Arm
9	1	Crank Bearing Spacer	59	1	Right Roller Arm
10	1	Rear Ramp Cover	60	1	Right Upper Body Leg
11	1	Incline Motor	61	1	Right Upper Body Arm
12	1	Incline Motor Arm	62	1	Left Upper Grip/Control Wire
13	1	Ramp Arm	63	2	Pulse Sensor/Wire
14	2	Ramp Arm Spacer	64	2	Pedal Arm Axle
15	1	Rear Stabilizer Cover	65	1	Right Arm Front Cover
16	2	Track	66	1	Right Arm Rear Cover
17	1	Power Switch	67	1	Left Arm Front Cover
18	1	Crank	68	1	Left Arm Rear Cover
19	1	Pulley	69	1	Right Leg Outer Cover
20	2	Crank Arm	70	1	Left Leg Outer Cover
21	1	Left Lower Grip	71	2	Disc
22	1	Idler	72	1	Left Leg Inner Cover
23	2	Short Bumper	73	1	Left Shield
24	1	Small Leveling Foot	74	1	Right Shield
25	1	Resistance Motor	75	1	Center Shield Cover
26	7	M10 Locknut	76	1	Left Pedal Arm Side Cap
27	2	M10 Washer	77	2	Crank Cover
28	1	Eddy Mechanism	78	2	Key
29	1	Right Pedal	79	1	Front Console Cover
30	4	Stabilizer Cap	80	1	Rear Console Cover
31	3	M10 x 19mm Screw	81	2	Lower Tray Cover
32	2	Roller Arm Bearing Spacer	82	8	M8 x 13mm Screw
33	2	Large Leveling Foot	83	1	Right Leg Inner Cover
34	2	Wheel	84	1	M4 x 12mm Ground Screw
35	2	Clip	85	2	M10 Split Washer
36	1	Idler Washer	86	2	M10 x 58mm Hex Bolt
37	1	Accessory Tray	87	1	Right Pedal Arm Side Cap
38	1	Reed Switch/Wire	88	1	Idler Pivot Screw
39	1	Reed Switch Clamp	89	1	Idler Screw
40	2	Frame Bearing	90	3	M6 x 19mm Washer
41	1	Upper Ramp Cover	91	1	Drive Belt Adjustment Screw
42	1	Sleeve	92	4	M10 x 25mm Screw
43	2	Magnet	93	4	M4 x 12mm Flange Screw
44	1	Left Pedal Arm	94	1	Left Control Pad
45	1	Left Roller Arm	95	8	M8 x 20mm Screw
46	1	Left Upper Body Leg	96	4	M8 x 45mm Bolt
47	1	Left Upper Body Arm	97	2	M8 x 28mm Washer
48	1	Strain-Relief Bushing	98	2	M8 x 18mm Washer
49	1	Left Pedal	99	1	Crank Pulley Spacer
50	6	M4 x 12mm Self-tapping Screw	100	4	Leg Bearing

Key No.	Qty.	Description	Key No.	Qty.	Description
101	53	M4 x 16mm Screw	127	2	Disc Bracket
102	6	M8 Locknut	128	1	Long Bumper
103	11	M6 x 12mm Screw	129	2	M8 x 22mm Washer
104	4	M10 x 115mm Screw	130	4	M4 x 12mm Screw
105	1	M4 x 25mm Flange Screw	131	2	Adhesive Tape
106	1	Lower Ramp Cover	132	1	Tablet Holder
107	1	Crank Spacer	133	4	Tablet Holder Screw
108	2	M6 x 13mm Screw	134	1	Right Lower Grip
109	2	M10 x 58mm Bolt	135	2	M6 x 26mm Washer
110	1	Main Wire	136	1	M10 x 28mm Washer
111	1	Left Extension Wire	137	1	Right Pedal Handle
112	2	M4 x 19mm Self-tapping Screw	138	2	Pedal Pin
113	1	Drive Belt	139	2	Pedal Spring
114	1	Controller	140	2	M6 Acorn Nut
115	4	Standoff	141	4	M6 Washer
116	2	Disc Ring	142	1	Right Pedal Plate
117	1	Front Shield Cover	143	1	Left Pedal Plate
118	1	Rear Shield Cover	144	2	M10 x 158mm Bolt
119	1	Power Cord	145	1	Motor Arm Spacer
120	2	M8 x 20mm Flat Head Screw	146	1	Chest Heart Rate Monitor
121	8	Frame Bushing	147	1	Right Extension Wire
122	1	M10 x 47mm Bolt	148	2	Zip Tie
123	2	Small Arm Bearing	149	1	Right Control Pad
124	2	M4 x 16mm Machine Screw	*	–	Assembly Tool
125	1	Right Upper Grip/Control Wire	*	–	Grease Packet
126	2	M4 x 25mm Screw	*	–	User's Manual

Note: Specifications are subject to change without notice. For information about ordering replacement parts, see the back cover of this manual. *These parts are not illustrated.

EXPLODED DRAWING B

Model No. NTEL71418.5 R1219A

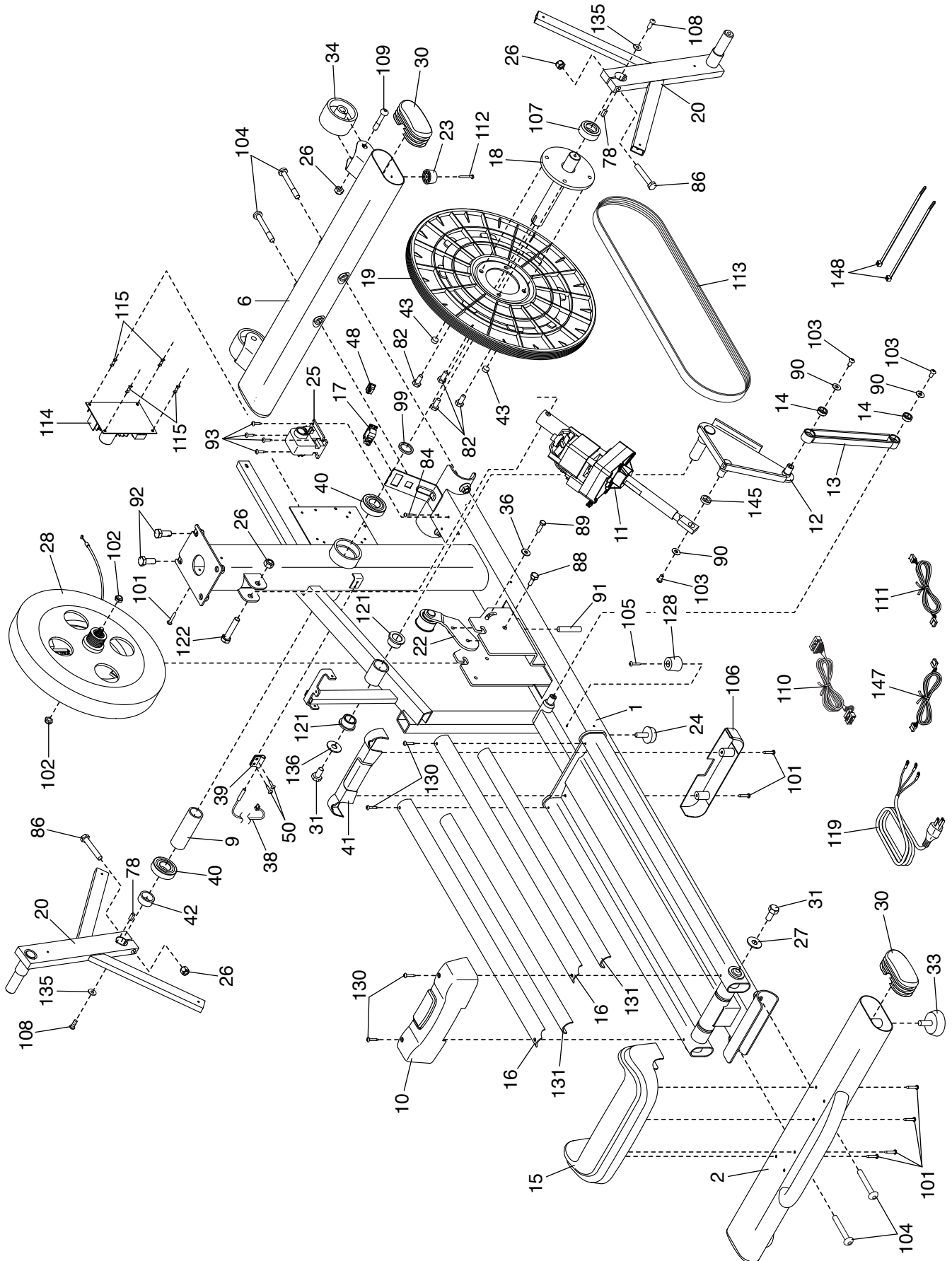

EXPLODED DRAWING C

Model No. NTEL71418.5 R1219A

