



FURUNO®

23" High resolution Multi-color LCD **MARINE RADAR** WITH ARPA AND AIS DISPLAY Models **FAR-2817/2827/2837S**

- Advanced signal processing for improved detection in rough sea
- LCD display providing crisp radar images
- Designed to comply with SOLAS carriage requirements for ships 10,000 GT and above
- Up to four radars can be interswitched in the network without an extra device
- Automatic plotting/tracking of 100 targets manually or automatically acquired
- Easy operation by customizable function keys, trackball/wheel palm module and rotary controls
- Low spurious magnetrons meeting ITU-R unwanted emission standards
- Displays 1000 AIS symbols



The future today with FURUNO's electronics technology.

FURUNO ELECTRIC CO., LTD.

9-52 Ashihara-cho, Nishinomiya City, Japan Phone: +81 (0)798 65-2111
Fax: +81 (0)798 65-4200, 66-4622 URL: www.furuno.co.jp

Catalogue No. R-185

TRADE MARK REGISTERED
MARCA REGISTRADA

FURUNO's user friendly concept and leading-edge technology are integrated! Reliable performance, Ease of installation



Full-keyboard Control Unit

The control head has logically arranged controls in a combination of push keys and trackball. Well organized menu ensures that all operations can be done by trackball.

Palm Control Unit

Alternative to the Full-keyboard Control Unit or additional as a remote operation.

The revolutionary FAR-28x7 series of X- and S-band radars are the result of FURUNO's 50 years of experience in marine electronics and advanced computer technology. This series is designed to meet the exacting standards of the International Maritime Organization (IMO) for ships 10,000 GT and above.

The display unit employs a 23.1" LCD which provides an effective picture diameter of larger than 340 mm. The SXGA monitor provides crisp radar images, which are presented in a selectable color with a day and night background color for easy observation in all lighting conditions. Different colors are assigned for marks, symbols and texts for user-friendly operations.

Target detection is enhanced by sophisticated signal processing techniques. Two guard zones can be set at required ranges in any sector. Other ship's movements are assessed by advanced target tracking software and alerted by CPA/TCPA data readouts. The FAR-28x7 series can display AIS-equipped ships, when connected with an AIS transponder.

The radar antenna is available with 4, 6.5, or 8 foot radiator. For the X-band, the rotation speed is selectable from 24 rpm for standard radars or 42 rpm for HSC. The S-band radar is also available with the antenna radiator of 10 or 12 feet. The S-band radar assures target detection in adverse weather where an X-band is heavily affected by sea or rain clutter.



This series of radar comply with the following IMO and IEC regulation:

- IEC 60936-1 shipborne radar
- IEC 60936-2 HSC radar
- IEC 60872-1 ARPA
- IEC 60872-2 ATA
- IEC 60837-3 EPA
- IEC 60945 General requirements
- IMO MSC.64(67) Annex 4
- IMO A.823(19)

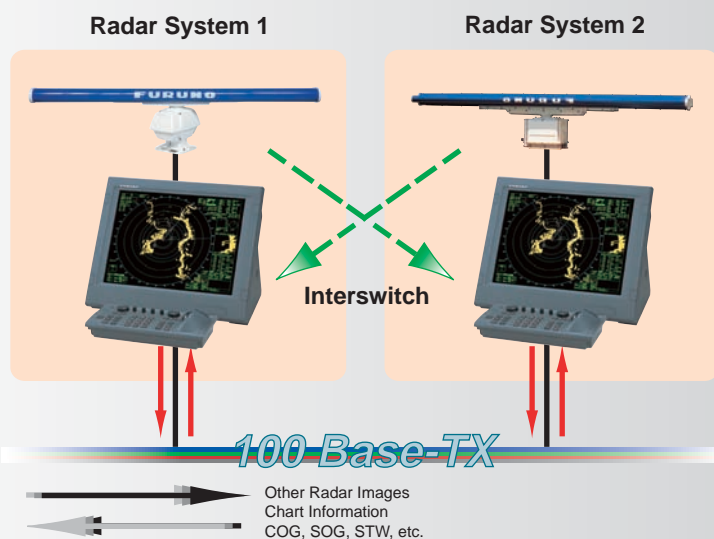

The radars can be connected to an Ethernet network for a variety of user requirements. SOLAS Chapter V as amended requires X- and S-band radars for ships 3000 GT and over. Each of X- and S-band radar can be interswitched without using an extra option. Up to four radars can be interchanged in the network. In addition, the essential navigational information including the electronic chart, L/L, COG, SOG, STW, etc. can be shared in the network.

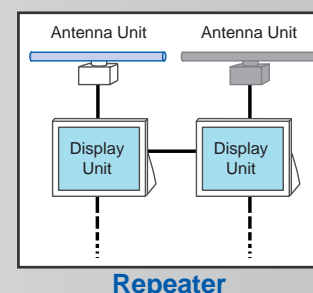
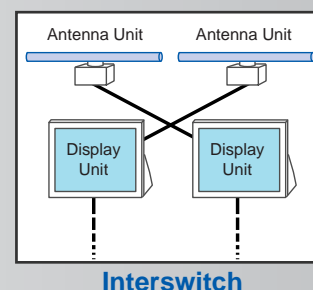
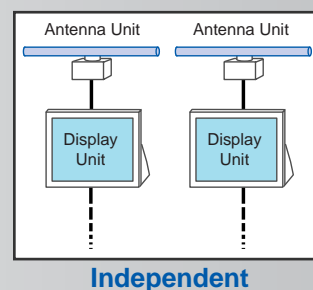

ARPA/AIS

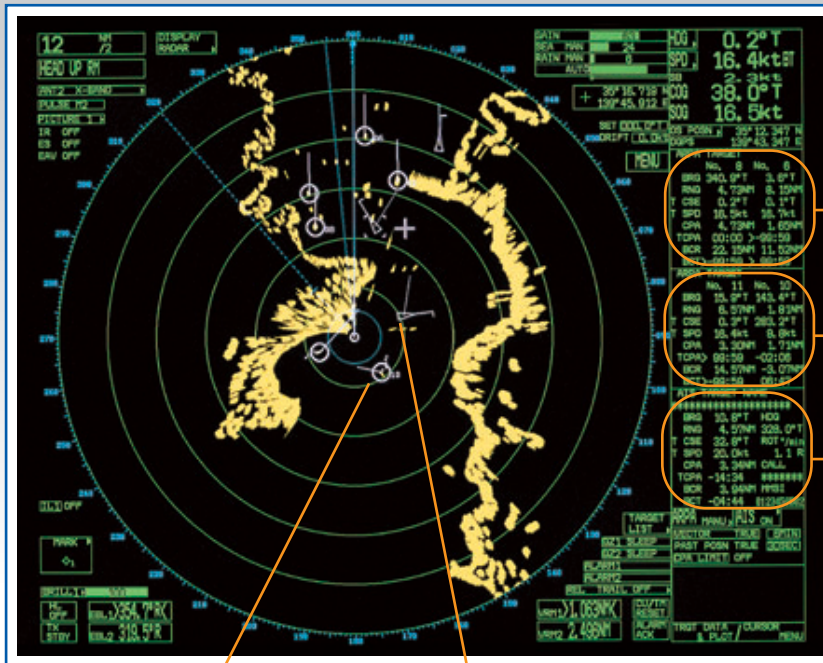

Own ship data cell

DATA Cell 1
ARPA data

DATA Cell 2
ARPA data

DATA Cell 3
ARPA data

Water temp, Anemometer

Magnify

AIS Information

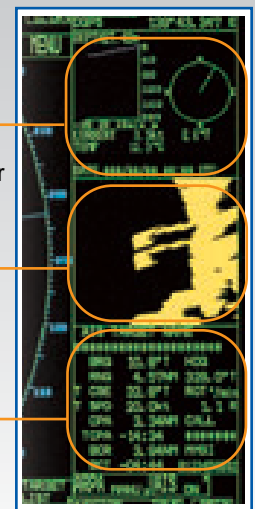

AIS-equipped target selected for data reading.

Targets automatically acquired

DATA DISPLAY

A variety of navigational information, own ship status, radar plotting data, wind, water temperature and information from other shipborne sensors are displayed on the cells. These selected targets are marked with a square symbol on the radar display. Magnify in a special feature of the FURUNO radars FAR-28x7 series. This looks like a delayed sweep zone that the IMO strictly prohibits, but it helps observe two symbols, AIS and ARPA, from the same physical target should be merged.

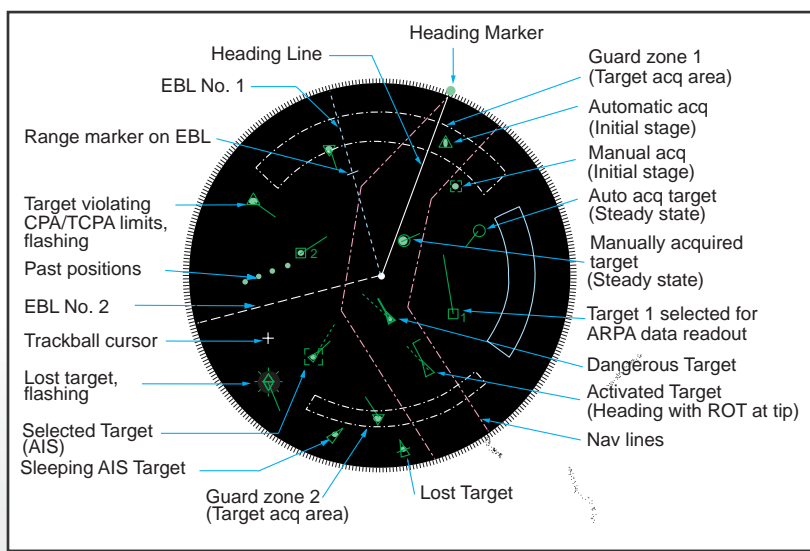

TARGET ASSOCIATION (Fusion)

An AIS-equipped ship may be displayed by both AIS and ARPA symbols. This is because the AIS position is measured by a GPS in L/L while the ARPA target is measured by range and bearing from own ship and located on the radar PPI. When the symbols are within an operator-set criteria, the ARPA symbol is merged in the AIS symbol. The criteria are determined by the differences in range, bearing, course, speed, etc.

AIS information

- **Static Data**
 - MMSI (Maritime Mobile Service Identity)
 - IMO number (Where available)
 - Call sign & name
 - Length and beam
 - Type of ship
 - Location of position-fixing antenna on the ship
- **Voyage related data**
 - Ship's draught
 - Hazardous cargo (type)
 - Destination and ETA (at masters discretion)
- **Dynamic data**
 - Ship's position with accuracy indication and integrity status
 - UTC
 - Course over ground (COG)
 - Speed over ground (SOG)
 - Heading
 - Navigation status (manual input)
 - Rate of turn (where available)
 - Update rates Dependent on speed and course alternation (2 s – 3 min)
- **Short safety-related messages**
 - Free messages

ALARM ZONES

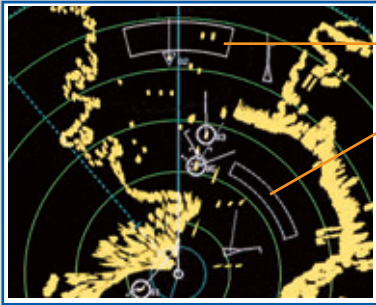

Guard Zone

Automatic Acquisition Zone

Two Automatic acquisition zones may be set in a sector or any form. They also act as suppression zones, avoiding unnecessary overloading to the processor and clutter by disabling automatic acquisition and tracking outside them. The operator can manually acquire important targets without restriction.

Guard Alarm Zone and Anchor Watch Zone

Targets that enter one of the Guard Alarm Zones change their symbols from a circle to an inverse triangle. Audible alarm is also released. One of Guard Alarm Zones may be used as an anchor watch where own ship or targets drift away from the set zone.

CPA Alarm Zone

Target tracking symbol changes to a triangle when its predicted course (vector) violates the operator set CPA/TCPA. The operator can readily change the vector lengths to evaluate target movement trend.

TARGET TRAILS

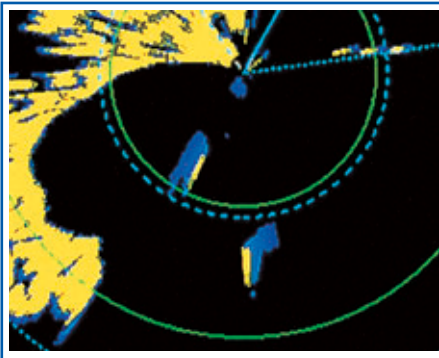

The target trails feature generates monotone or gradual shading afterglow on all objects on the display. The shading afterglow paints the display just like on an analog PPI. The monotone trails are useful to show own ship movement and other ship tracks in a specific fishing operation. The trail time is adjustable for 15, 30 s, 1, 3, 6, 15, 30 min or continuous. The target trails are indicated in a different color from background. The unique feature in this radar is a choice of True or Relative mode in Relative Motion (only True in TM).

CHART OVERLAY

This radar incorporates a VideoPlotter that allows to display electronic charts (C-MAP NT+, Navionics NavCharts), plot own and other ship's track, enable entry of waypoints/routes, and make a radar map. Chart is displayed in combination of radar images (overlaid with radar images).



RADAR MAP

Up to 200 waypoints and up to 30 routes can be stored. Each route may contain up to 30 waypoints. A radar map is a combination of map lines and marks whereby the user can define and input the navigation area, route planning and monitoring data. The radar map has the capacity of 3,000 points for map lines and marks. The map data can be memorized to facilitate repeated use on a routine navigation area.

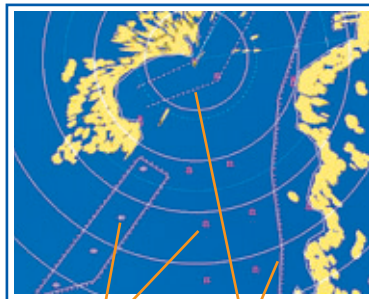

Map Marks

Map Lines

NIGHT VIEW

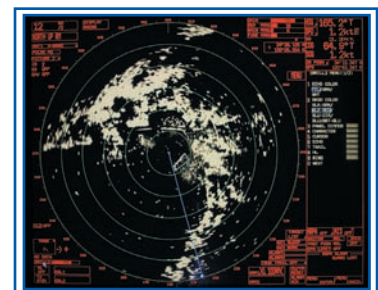

Specifications of FAR-2817/2827/2837S

Antenna Radiators

- 1. Type** Slotted waveguide array
- 2. Beamwidth and sidelobe attenuation**

Radiator Type	X-Band			S-Band	
	XN-12AF	XN-20AF	XN-24AF	SN-30AF	SN-36AF
Length	4 ft	6.5 ft	8 ft	10 ft	12 ft
Beamwidth(H)	1.9°	1.23°	0.95°	2.3°	1.8°
Beamwidth(W)	20°	20°	20°	25°	25°
Sidelobe (within ± 10°)	-24 dB	-28 dB	-28 dB	-24 dB	-24 dB
Sidelobe (outside ± 10°)	-30 dB	-32 dB	-32 dB	-30 dB	-30 dB

- 3. Rotation** X band: 24 rpm or 42 rpm
S band: 21 rpm (50Hz), 26 rpm (60Hz) or 45 rpm

RF Transceiver

1. Frequency

X-band: 9410 MHz ±30 MHz
S-band: 3050 MHz ±30 MHz

2. Output power

FAR-2817: 12 kW
FAR-2827: 25 kW
FAR-2837S: 30 kW

3. Pulselength/PRR

Range scale (nm)	Pulselength (µs)	PRR (Hz)
0.125, 0.25	0.07	3000
0.5	0.07, 0.15	3000
0.75, 1.5	0.07, 0.15, 0.3	3000, 1500
3	0.15, 0.3, 0.5, 0.7	3000, 1500, 1000
6	0.3, 0.5, 0.7, 1.2	1500, 1000, 600
12, 24	0.5, 0.7, 1.2	1000, 600
48, 96	1.2	600

4. I.F. 60 MHz, Logarithmic

Bandwidth
Short pulse: 40 MHz
Middle pulse: 10 MHz
Long pulse: 3 MHz

RADAR DISPLAY

1. Picture tube

23" color LCD (SXGA 1280 x 1024 pixels),
470 (H) x 353 (V) mm,
Effective display diameter 340 mm
Echo Color: Yellow, green or white in 32 levels

2. Minimum range: 20 m on 0.25 nm range scale

3. Range scales and ring intervals (nm)

Range: .125, .25, .5, .75, 1.5, 3, 6, 12, 24, 48, 96
Ring: .025, .05, .1, .25, .25, .5, 1, 2, 4, 8, 16

4. Range accuracy

0.2 % of range in use or 2 m whichever is the greater

5. Range discrimination

20 m on 0.25 nm range scale

6. Presentation modes

Head-Up, Head-Up, Course-Up, North-Up, North-Up TM

7. Parallel index lines

1, 2, 3 or 6 lines (menu selectable)

8. Radar map

1500 points to create coastlines, own ship safety contour, isolated underwater dangers, buoys, traffic routing systems, prohibited areas, fairways as required by IMO.

Automatic Plotting

1. Acquisition

100 targets (e.g. manually 50, automatically 50)

2. Tracking

Automatic tracking of all acquired targets in 0.1 to 32 nm

3. Guard zone (Target Acquisition Area)

Two guard zone, one of them 0.5 nm depth

4. Vector

True or relative 30 s, 1, 3, 6, 15, 30 min for prediction of target motion

5. Past positions

5 or 10 past positions at intervals of 30 s, 1, 2, 3, 6 min.

6. Collision warning

CPA limit: 0.2 - 10 nm, TCPA limit: 0 - 99 min.

7. Trial maneuver

Dynamic or static, with selected delay time.

AIS FUNCTIONS (Data input from AIS is required)

1. Symbols

Sleeping, Activated, Dangerous, Selected, Lost targets

2. Number of targets

1,000 targets max.

3. Data indication

Basic and expanded data

POWER SUPPLY (specify when ordering)

1. Processor Unit

24 VDC or 115/230 VAC, 1ø, 50/60 Hz
440 VAC, 1ø, 50/60 Hz with optional transformer RU-1803

2. Display Unit

24 VDC or 115/230 VAC, 1ø, 50/60 Hz
440 VAC, 1ø, 50/60 Hz with optional transformer RU-1803

3. Antenna Unit

FAR-2837S:
230 VAC, 3ø, 60 Hz; 380 VAC, 3ø, 50 Hz; 440 VAC, 3ø, 60 Hz
115 VAC, 3ø, 60 Hz with optional transformer RU-5693
230 VAC, 3ø, 50 Hz with optional transformer RU-6522
440 VAC, 3ø, 50 Hz with optional transformer RU-5466-1

X-band antenna for FAR-2817, 2827



S-band antenna for FAR-2837S

(Coming next spring.)



FAR-2817: X-band, 12 kW, TR up
FAR-2827: X-band, 25 kW, TR up
FAR-2837S: S-band, 30 kW, TR up

EQUIPMENT LIST

Standard

1. Display Unit MU-231CR
2. Processor Unit RPU-013
3. Full-keyboard Control Unit RCU-014
Trackball Control Unit (Palm Control Unit) RCU-015
(Specify when ordering)
4. Antenna Unit with cable (15/20/30/50/100 m)
5. RF Transceiver Unit for RF-up system
6. Power Supply Unit PSU-007 for FAR-2837s
7. Standard Spare Parts and Installation Materials

Option

1. Remote Control Unit RCU-016
2. Gyro Interface GC-10 (built in Processor Unit)
3. RGB Buffer Board (built in Processor Unit)
4. RGB Connector DSUB-BNC-1 (for VDR)
5. Card Interface Unit CU-100
6. Transformer RU-1803/3305/5466-1/5693/6522
7. Rectifier RU-3424/1746B
8. Junction Box for Antenna Cable
9. External Alert Buzzer
10. MINI Chart Card
11. Hand Grip FP03-09840
12. Bracket FP03-09820
13. Pedestal

VOYAGER

The display unit can be supplied in a special cabinet matching the FURUNO New INS configuration as FAR-28x7 series.



Optional pedestal



INTERCONNECTION DIAGRAM

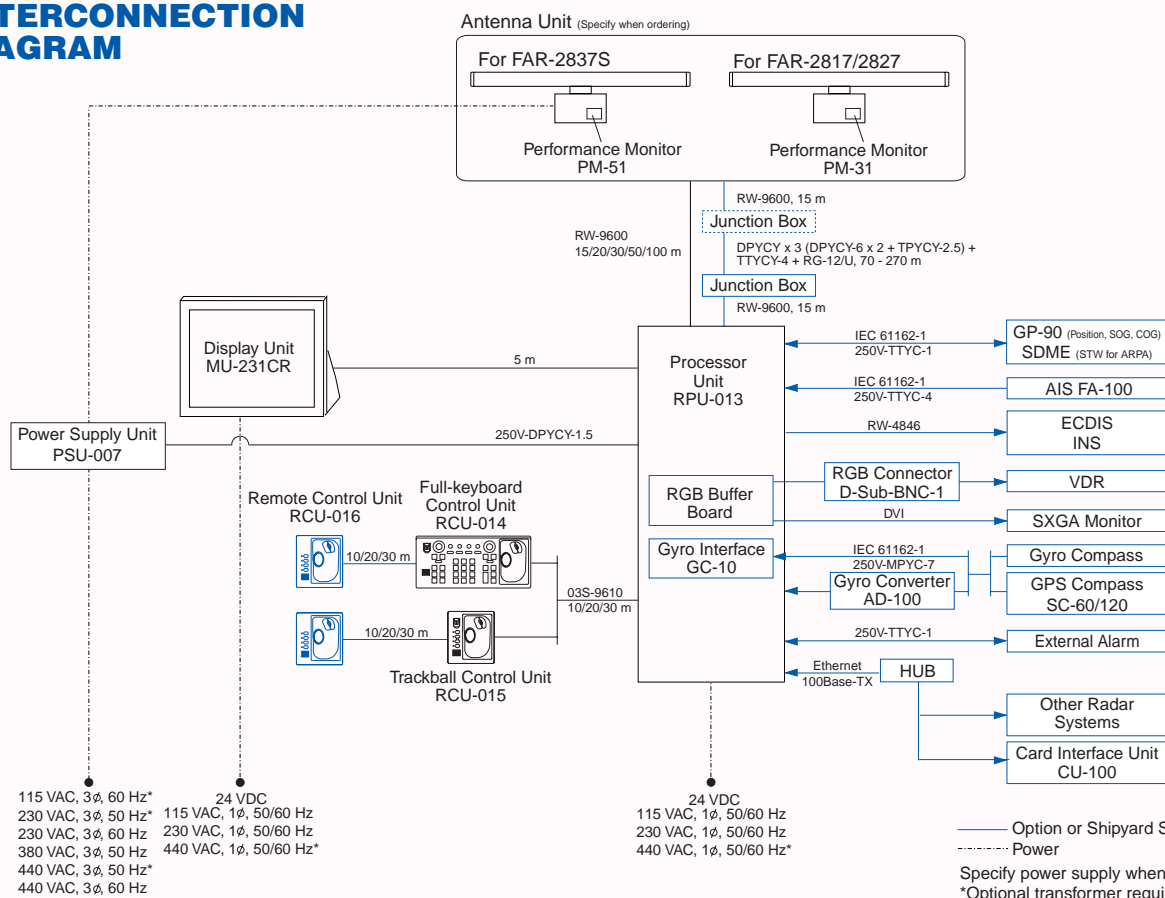

Antenna Unit for FAR-2817/2827 RSB-096/097

XN-12AF: 33 kg 73 lb

XN-20AF: 39 kg 86 lb
XN-24AF: 42 kg 93 lb

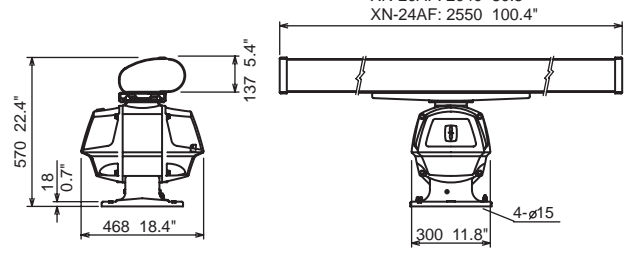
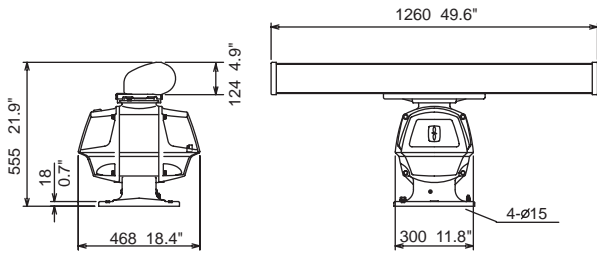

Antenna Unit for FAR-2837S RSB-098/099/100/101/102

SN-30AF: 127 kg 280 lb
SN-36AF: 133 kg 293.2 lb

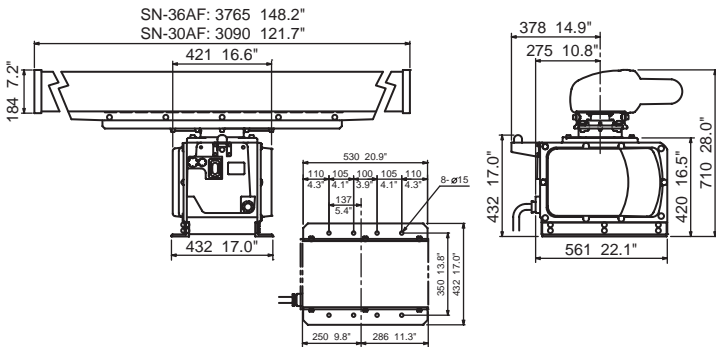

Processor Unit RPU-013 10 kg 22 lb

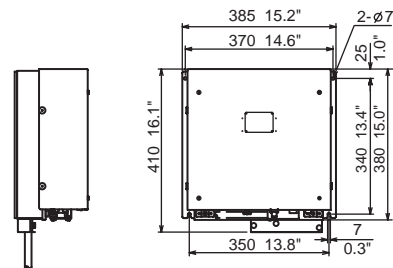

Display Unit MU-231CR 23.5 kg 51.8 lb

Bracket mount

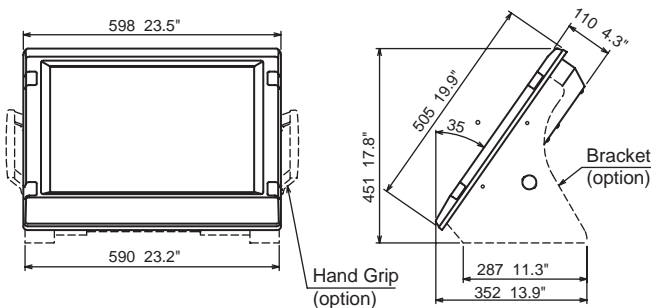

Panel mount

16.6 kg 36.6 lb

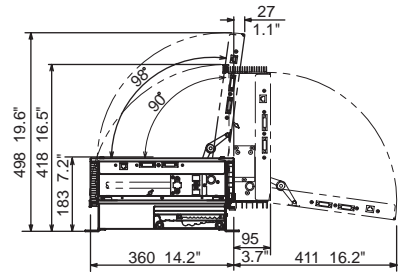
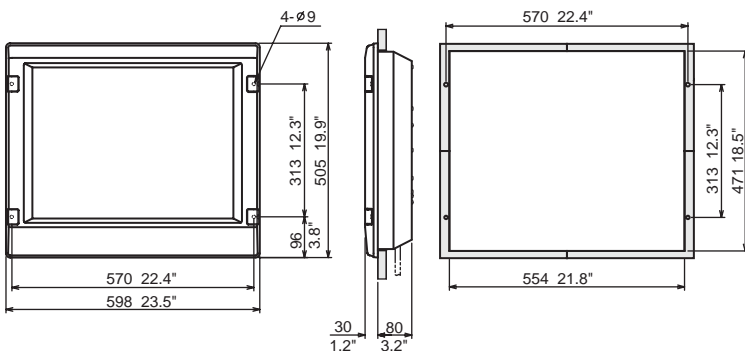

Full-keyboard Control Unit RCU-014

3.7 kg 8.2 lb

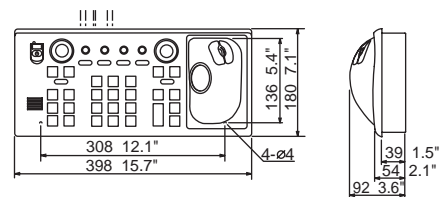

Trackball Control Unit RCU-015
Remote Control Unit RCU-016

2.4 kg 5.3 lb

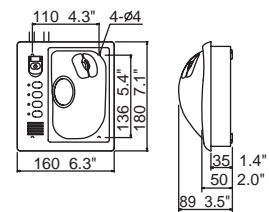

FURUNO U.S.A., INC.
Camas, Washington, U.S.A.
Phone: +1 360-834-9300 Telefax: +1 360-834-9400

FURUNO (UK) LIMITED
Denmead, Hampshire, U.K.
Phone: +44 2392-230303 Telefax: +44 2392-230101

FURUNO FRANCE S.A.
Bordeaux-Mérignac, France
Phone: +33 5 56 13 48 00 Telefax: +33 5 56 13 48 01

FURUNO ESPAÑA S.A.
Madrid, Spain
Phone: +34 91-725-90-88 Telefax: +34 91-725-98-97

FURUNO DANMARK AS
Hvidovre, Denmark
Phone: +45 36 77 45 00 Telefax: +45 36 77 45 01

FURUNO NORGE A/S
Ålesund, Norway
Phone: +47 70 102950 Telefax: +47 70 127021

FURUNO SVERIGE AB
Västra Frölunda, Sweden
Phone: +46 31-7098940 Telefax: +46 31-497093

FURUNO FINLAND OY
Espoo, Finland
Phone: +358 9 4355 670 Telefax: +358 9 4355 6710

03115Y Printed in Japan



IKM Instrutek AS

Elveveien 28 • 3262 Larvik
Tlf. 33165700 • Faks 33165701
post@instrutek.no • www.instrutek.no