



Models 110, 111 & 112

Multimeters

Calibration Information

Introduction

The Fluke **Model 110**, **Model 111**, and **Model 112** True RMS multimeters (hereafter "the Meter") are battery-powered, with a 6000-count display and a bar graph.

This calibration information applies to all three models. All figures show the Model 112.

The Meter measures or tests the following:

- AC and DC voltage
- Resistance
- Continuity
- Diodes
- Frequency
- Capacitance
- AC and DC current (Model 111 and Model 112)

"Warning" and "Caution" Statements

A "**⚠ Warning**" statement identifies hazardous conditions and actions that could cause bodily harm or death.

A "**Caution**" statement identifies conditions and actions that could damage the Meter or the equipment under test.

Unsafe Voltage Symbol

To alert you to the presence of a potentially hazardous voltage, the f symbol is displayed when the Meter detects a voltage ≥ 30 V or a voltage overload (OL) condition.

Test Lead Alert

⚠ Warning

Personal injury or damage to the Meter can occur if you attempt to make a measurement with a lead in an incorrect terminal.

To remind you to check that the test leads are in the correct terminals, **LEAD** is displayed briefly when you move the rotary switch to or from any A position.

These Meters meet CAT III IEC 61010-1-95 standards. The IEC 61010-1-95 safety standard defines four overvoltage categories (CAT I to IV) based on the magnitude of danger from transient impulses. CAT III meters are designed to protect against transients in fixed-equipment installations at the distribution level.

⚠ Warning

To avoid electric shock or injury, do not perform the performance tests or calibration procedures unless you are qualified to do so.

The information provided in this manual is for the use of qualified personnel only.

This document provides the information necessary to calibrate and verify the performance of the Fluke Model 110, 111, and 112 multimeters.

The following information is included:

- Safety Information and international symbols (Page 3)
- Specifications (Pages 4 - 5)
- Testing the fuse (Page 6)
- Replacing the battery and fuse (Pages 7 - 8)
- Replacing the LCD (Pages 9 - 10)
- Performance tests (Pages 10 - 12)
- Calibrating the Meter (Pages 13 - 14)
- Display messages (Page 14)
- Cleaning the Meter (Page 15)
- User-replaceable parts (Page 16)

See the *Models 110, 111 & 112 Users Manual* for operating instructions.

Warranty and Service Information

The Meter has a three year limited warranty, which is printed in the Users Manual.

To contact Fluke, call:

- 1-888-99-FLUKE (1-888-993-5853) in USA and Canada
- +31 402-678-200 in Europe
- +81-3-3434-0181 Japan
- +65-276-6196 Singapore
- +1-425-446-5500 in other countries

For additional information about Fluke, its products, and services, visit Fluke's web site at:

www.fluke.com

Safety Information













⚠ Warnings and Precautions

To avoid possible electric shock or personal injury, follow these guidelines:

- Use the Meter only as specified in this manual or the protection provided by the Meter might be impaired.
- Do not use the Meter or test leads if they appear damaged, or if the Meter is not operating properly.
- Always use proper terminals, switch position, and range for measurements.
- Verify the Meter's operation by measuring a known voltage. If in doubt, have the Meter serviced.
- Do not apply more than the rated voltage, as marked on the Meter, between terminals or between any terminal and earth ground.
- Use caution with voltages above 30 V ac rms, 42 V ac peak, or 60 V dc. These voltages pose a shock hazard.
- To avoid false readings that can lead to electric shock and injury, replace the battery as soon as the low battery indicator (🔋) appears.
- Disconnect circuit power and discharge all high-voltage capacitors before testing resistance, continuity, diodes, or capacitance.
- Do not use the Meter around explosive gas or vapor.
- When using test leads or probes, keep your fingers behind the finger guards.
- Remove test leads from the Meter before opening the battery door or the Meter case.

International Symbols

The following international symbols appear in this document and on the Meter.

	AC (Alternating Current)		Earth ground
	DC (Direct Current)		Conforms to European Union directives
	AC or DC		Canadian Standards Association
	Fuse		Double insulated
	Important Information. Refer to the manual.		Underwriters Laboratories, Inc.
	Battery (Low battery when shown on the display)		Conforms to relevant Australian standards
	Inspected and licensed by TÜV Product Services		

Specifications

Accuracy is specified for 1 year after calibration, at operating temperatures of 18 °C to 28 °C (64 °F to 82 °F), with relative humidity at 0 % to 95 %.

The accuracy specifications take the form of: $\pm ([\% \text{ of Reading }] + [\text{ Counts }])$

Maximum voltage between any terminal and earth ground:	600 V
Surge Protection:	6 kV peak per IEC 61010-1-95
⚠ Fuse for A input:	11 A, 1000 V FAST Fuse

Display:	Digital: 6,000 counts, updates 4/sec
	Bar Graph: 33 segments, updates 40/sec
	Frequency: 9,999 counts
	Capacitance: 9,999 counts
Temperature:	Operating: -10 °C to +50 °C
	Storage: -30 °C to +60 °C
Temperature Coefficient:	0.1 x (specified accuracy)/ °C for <18 °C or > 28 °C

Electromagnetic Compatibility:	Performance ≥ 3 V/m is not specified.
Relative Humidity:	Noncondensing < 10 °C 0 % to 95 % @ 10 °C to 30 °C 0 % to 75 % @ 30 °C to 40 °C 0 % to 45 % @ 40 °C to 50 °C
Battery Life:	Alkaline: 300 hours typical, without backlight
Size, with Holster (H x W x L):	4.6 cm x 9.6 cm x 16.0 cm
Weight:	350 g
Safety Compliance:	ANSI/ISA-S82.01-1994, CSA C22.2 No 1010.1-92 and IEC 61010-1-95 Overvoltage Category III (CAT III), 600 V
Certifications:	UL (3111), CE, CSA, TÜV, (N10140)

Function	Range	Resolution	Accuracy $\pm ([\% \text{ of Reading }] + [\text{ Counts }])$		
			Model 110	Model 111	Model 112
AC Volts ^{1,2} - True RMS (50 Hz to 500 Hz)	6000 mV ³ 6.000 V 60.00 V 600.0 V	1 mV 0.001 V 0.01 V 0.1 V	1.0 % + 3	1.0 % + 3	1.0 % + 3
DC Volts	6000 mV ³ 6.000 V 60.00 V 600.0 V	1 mV 0.001 V 0.01 V 0.1 V	0.7 % + 2	0.7 % + 2	0.7 % + 2
Continuity	600 Ω	1 Ω	Beeper guaranteed on < 20 Ω , guaranteed off > 250 Ω ; detects opens or shorts of 250 μ s or longer.		
Ohms	600.0 Ω 6.000 k Ω 60.00 k Ω 600.0 k Ω 6.000 M Ω 40.00 M Ω	0.1 Ω 0.001 k Ω 0.01 k Ω 0.1 k Ω 0.001 M Ω 0.01 M Ω	0.9 % + 2 0.9 % + 1 0.9 % + 1 0.9 % + 1 0.9 % + 1 1.5 % + 3	0.9 % + 2 0.9 % + 1 0.9 % + 1 0.9 % + 1 0.9 % + 1 1.5 % + 3	0.9 % + 2 0.9 % + 1 0.9 % + 1 0.9 % + 1 0.9 % + 1 1.5 % + 3

1. AC voltage ranges are specified from 5% of range to 100% of range.
2. Crest factor of ≤ 3 at full scale up to 300 V, decreasing linearly to crest factor ≤ 1.5 at 600 V.
3. The 6000 mV range can only be entered in Manual Range mode. Use the 6000 mVDC range with accessories.

Specifications (continued)

Function	Range	Resolution	Accuracy \pm ([% of Reading] + [Counts])		
			Model 110	Model 111	Model 112
Diode test	2.200 V	0.001 V	0.9 % + 2		
Capacitance ⁴	1000 nF 10.00 μ F 100.0 μ F 10000 μ F	1 nF 0.01 μ F 0.1 μ F 1 μ F	1.9 % + 2	1.9 % + 2	1.9 % + 2
			1.9 % + 2	1.9 % + 2	1.9 % + 2
			100 μ F - 1000 μ F: 1.9% + 2 > 1000 μ F: 10% + 90 typical		
AC Amps ⁵ - True RMS (50 Hz to 500 Hz) (Models 111 and 112)	10.00 A continuous or 20 A overload for 30 seconds maximum	0.01 A	N/A	1.5 % + 3	1.5 % + 3
DC Amps (Models 111 and 112)	6.000 A 10.00 A continuous or 20 A overload for 30 seconds maximum	0.001 A 0.01 A	N/A	1.0 % + 3	1.0 % + 3
Hz ⁶ (V or A input)	99.99 Hz 999.9 Hz 9.999 kHz 50.00 kHz	0.01 Hz 0.1 Hz 0.001 kHz 0.01 kHz	0.1 % + 2	0.1 % + 2	0.1 % + 2
MIN MAX AVG Accuracy and Response Time	Accuracy is the specified accuracy of the measurement function \pm 12 digits for changes >200 ms in duration (\pm 40 digits in AC). Typical response time: 100 ms to 80 % of signal, except V AC and A AC.				

4. For film capacitors.

5. Crest factor of \leq 3. AC current is not specified below 3A.

6. Hz is specified from 5 Hz to 50 kHz in volts, from 50 Hz to 5 kHz in amps.

Function	Input Impedance (Nominal)	Common Mode Rejection Ratio		Normal Mode Rejection
Volts AC	> 5 M Ω < 100 pF	> 60 dB at DC, 50 Hz or 60 Hz		
Volts DC	> 10 M Ω < 100 pF	> 100 dB at DC, 50 Hz or 60 Hz		> 50 dB at 50 Hz or 60 Hz
	Open Circuit Test Voltage	Full Scale Voltage		Short Circuit Current
		To 6 M Ω	40 M Ω	
Ohms	< 1.5 V DC	< 600 mV DC	< 1.5V DC	< 500 μ A
Diode test	2.4 to 3.0 V DC	2.400 V DC		1.2 mA typical

Testing the Fuse (Models 111 and 112)

⚠ Warning

To avoid electrical shock or injury, remove the test leads and any input signals before replacing the fuse.

Test the fuse as shown below.

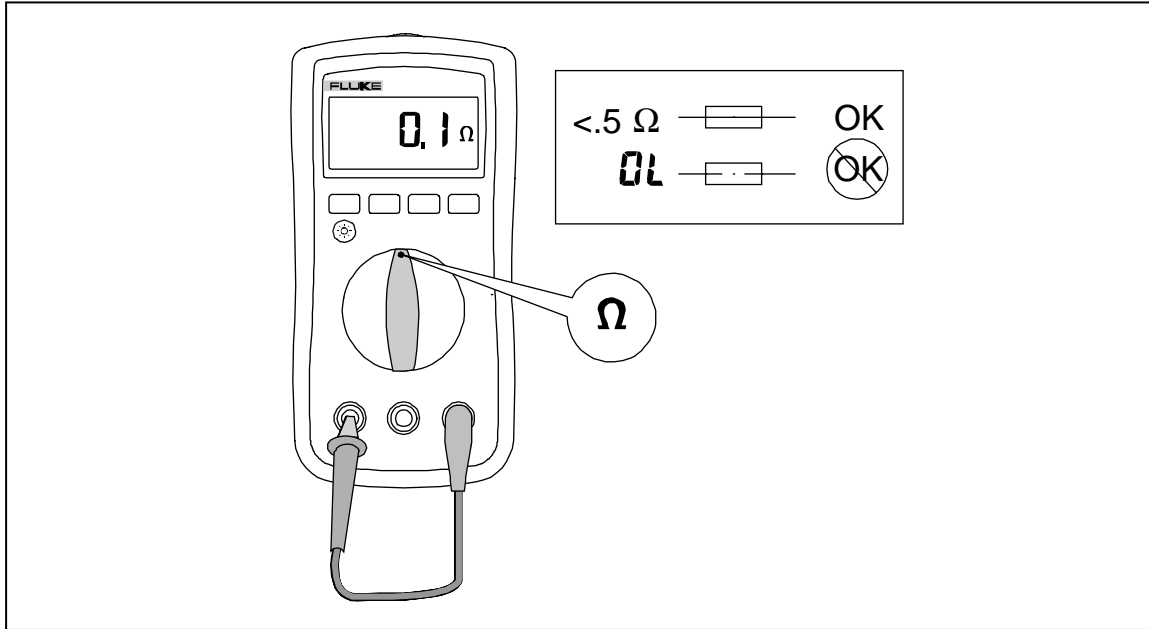

aej12f.wmf

Figure 1. Testing the Fuse

Replacing the Battery and Fuse

⚠ Warning

To avoid electric shock, injury, or damage to the Meter:

- Remove test leads from the Meter before opening the case or battery door.
- Use **ONLY** a fuse with the amperage, interrupt, voltage, and speed ratings specified.
- Replace the battery as soon as the low battery indicator () appears to avoid false readings.

To replace the battery

1. Turn the rotary switch to **OFF** and remove the test leads from the terminals.
2. Lift the tilt stand to access the battery door.
3. Remove the screw from the battery door.
4. Use the finger recess to lift the battery door slightly.
5. Pull the door toward the bottom of the Meter to release the latch.
6. Lift the battery door straight up to separate it from the case. You can now remove and replace the battery.

The battery fits inside the battery door, which is then inserted straight into the case until it clicks into place. Do not attempt to install the battery directly into the case.

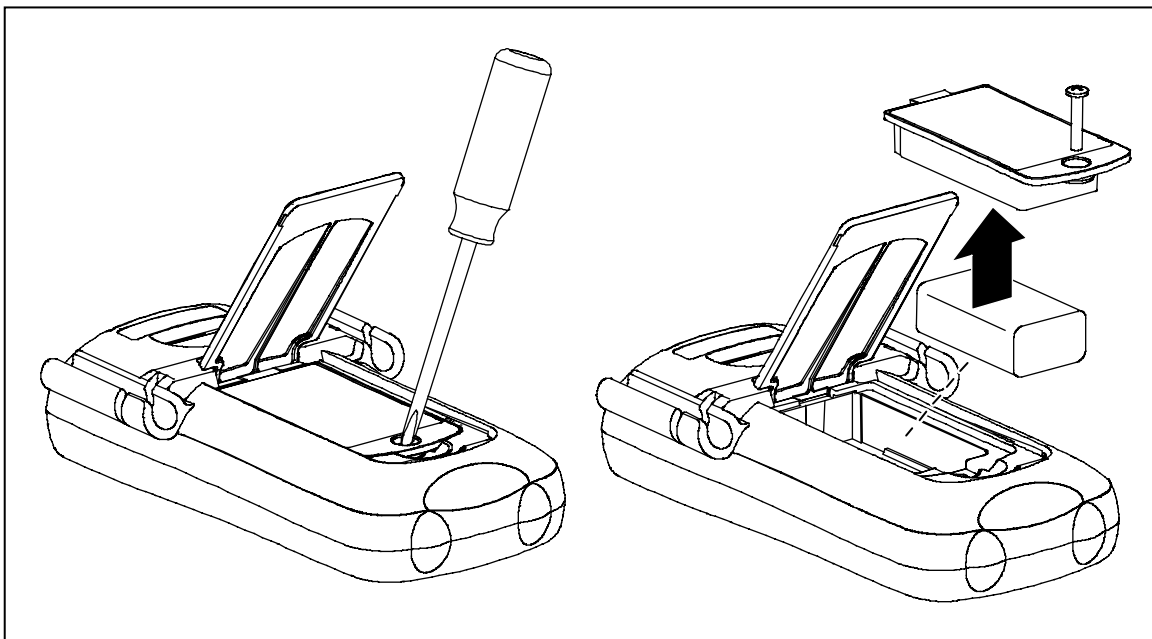

Figure 2. Replacing the Battery

aej14f.wmf

To replace the fuse (Models 111 and 112)

1. Turn the rotary switch to **OFF** and remove the test leads from the terminals.
2. Remove the Meter from the protective yellow holster.
3. Remove the battery and battery door.
4. Remove the two screws holding the case together.
5. Remove the bottom case and set it aside.
6. Remove and replace the fuse.
7. Reassemble the case and reinstall the battery, battery door, screws, and holster.

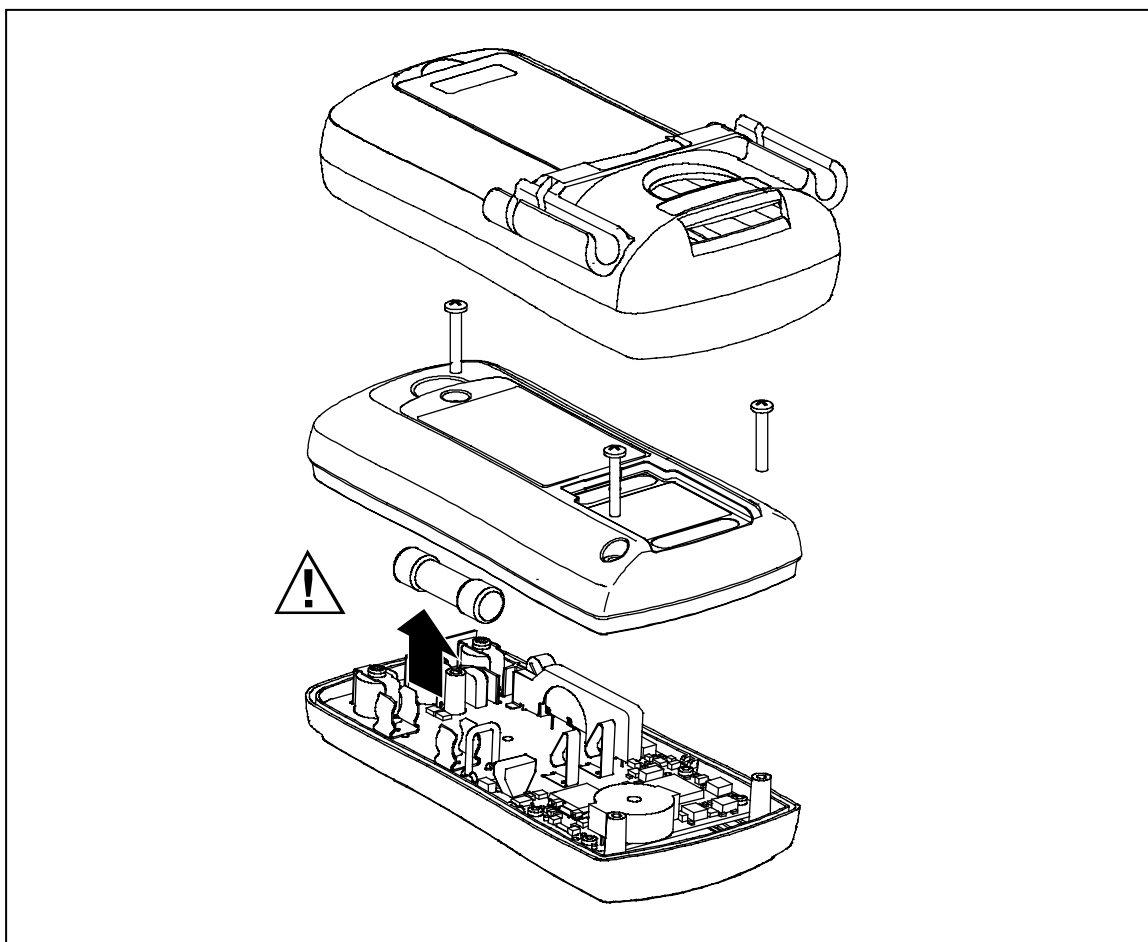

Figure 3. Replacing the Fuse

aej15f.wmf

Replacing the LCD

You must remove the circuit board assembly to access and replace the LCD.

Caution

The circuit board is extremely susceptible to contamination. To avoid contamination, handle it by the input receptacle, fuse clips, or edges of the board only. You can also use clean surgical gloves to help avoid contamination.

To replace the LCD

1. Turn the rotary switch to **OFF** and remove the test leads from the terminals.
2. Open the case as described earlier.
3. Remove the 3 Phillips screws securing the input terminals to the case top.
4. Pry the board out of the case using the tip of a thin screwdriver. Lift the circuit board out carefully to avoid contamination.

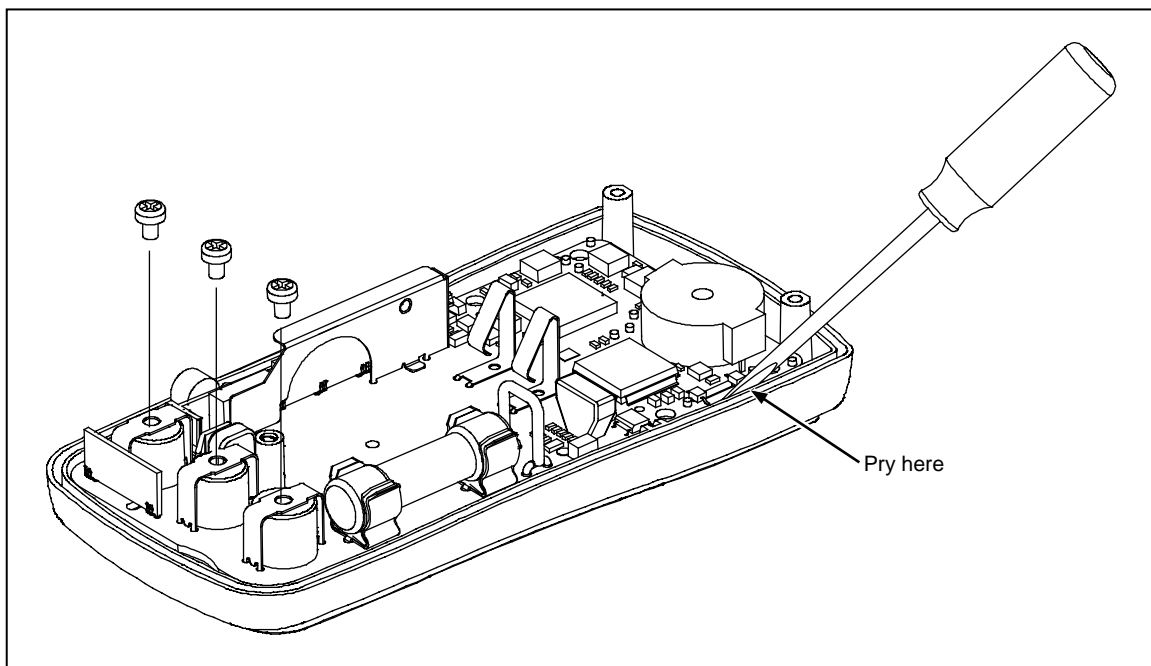

aej17f.wmf

Figure 4. Removing Screws on the PCA

5. Carefully insert the tip of a thin screwdriver under the LCD mask at the top of the display as shown in Figure 5.
6. Lift up the LCD mask gently with the screwdriver blade to loosen the mask from the assembly. Be careful to press upward, not inward toward the LCD. Tilt the LCD mask upward to release.
7. Replace the LCD. Center the LCD on the platform between the brackets before you replace the LCD mask. If the LCD is improperly aligned, the display may show missing segments, meaningless readings, or the LCD might break.

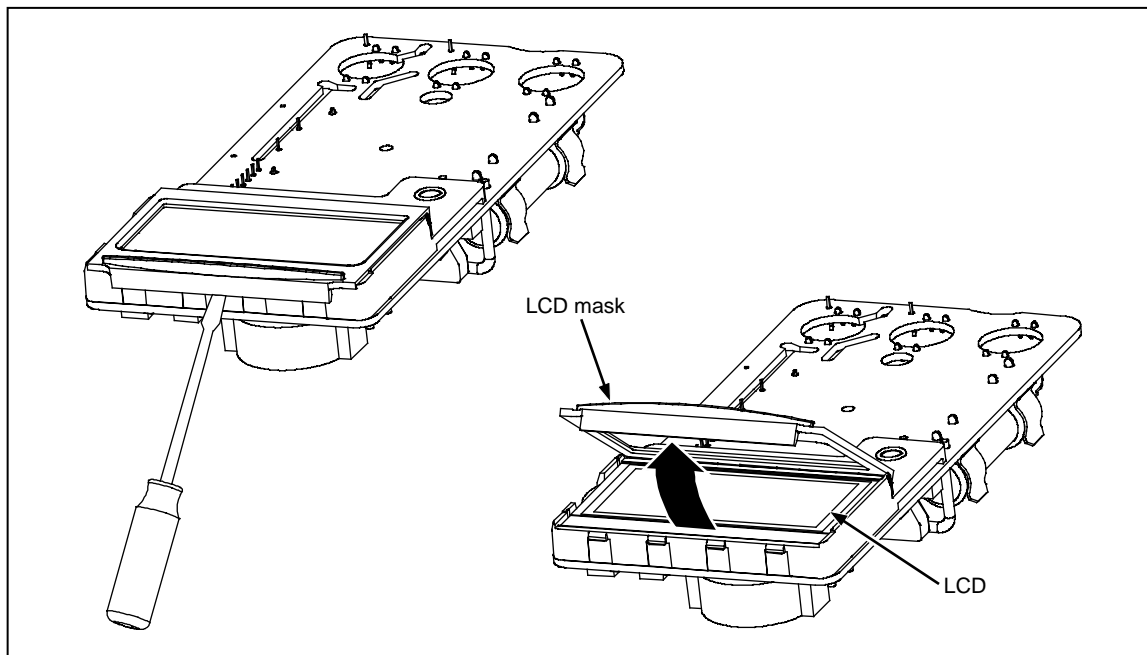

aej18f.wmf

Figure 5. Removing the LCD Mask

8. Reattach the LCD mask by pressing it over the LCD until it snaps into place.
9. Place the PCA into the case top with the LCD showing through the window and snap the PCA into place. Carefully replace the 3 Phillips screws that connect the PCA to the case top.
10. Verify that the rotary switch is in the **OFF** position.
11. Reassemble the case and reinstall the battery, battery door, screws, and holster.

Performance Tests

⚠ Warning

To avoid electric shock, do not execute the performance tests procedures unless the Meter is fully assembled.

The following performance tests verify the complete operability of the Meter and check the accuracy of each meter function against the Meter's specifications (i.e., calibration). If the instrument fails any part of the test, calibration adjustment and/or repair is indicated.

In the performance tests, the Meter is referred to as the unit under test (UUT).

Required Equipment

A Fluke 5500A Multi-Product Calibrator (or equivalent) is required for the performance test procedures in this document.

If an equivalent calibrator is used, it must meet the accuracy specifications shown in Table 1.

Table 1. Calibrator Specifications

Equipment	Measurement Function	Accuracy
5500A Multi-Product Calibrator (or equivalent)	DC Volts	0 to 600 V ± 0.175 %
	DC Current	0 to 10 A ± 0.25 %
	AC Volts	0 to 600 V ± 0.25 % @ 50 Hz to 500 Hz
	AC Current	0 to 10 A 0.375% @ 50 Hz to 500 Hz
	Resistance	0 to 6 MΩ ± 0.225 % 6 to 30 MΩ ± 0.375 %
	Capacitance	100 nF to 1 μF ± 0.475 %
	Frequency	50 Hz to 50 kHz ± 0.025 % @ 5 V

Preparing for the Performance Test

⚠ Warning

To avoid electric shock or personal injury:

- Do not perform the following procedures unless qualified to do so. Some procedures involve the use of high voltages.
- Always put the calibrator in the Standby mode (STBY) between tests and before handling the test connections.

To prepare for the performance test

1. Allow the temperature of the UUT to stabilize at room temperature ($23\text{ °C} \pm 5\text{ °C}$ [$73\text{ °F} \pm 9\text{ °F}$]).
2. Check the fuse and battery, and replace them if necessary. (Refer to the battery and fuse replacement procedures later in this document for more information.)

Table 2. Performance Test Steps

Function (switch position)	Input value	Frequency (sine wave)	Display	
			Lower Limit	Upper Limit
\tilde{V}	300 mV	50 Hz	0.294	0.306
	300 mV	500 Hz	0.294	0.306
	5 V	50 Hz	4.947	5.053
	5 V	500 Hz	4.947	5.053
	50 V	500 Hz	49.47	50.53
	600 V	500 Hz	593.7	606.3
$\tilde{V} + \text{Hz}$	5 V	50 kHz	49.93	50.07
$\overline{\tilde{V}}$	0 V	0 Hz	-0.002	0.002
	5 V		4.994	5.006
	-50 V		-49.94	-50.06
	600 V		599.4	600.6
Ω	20 Ω	N/A	Beeper On	
	250 Ω		Beeper Off	
Ω	0 Ω	N/A	-0.2	0.2 ¹
	500 Ω		495.3	504.7 ¹
	5 k Ω		4.954	5.046
	50 k Ω		49.54	50.46
	500 k Ω		495.4	504.6
	5 M Ω		4.954	5.046
	30 M Ω		29.52	30.48
\rightarrow	2 V	0 Hz	1.980	2.020
\leftarrow	0.8 μF	N/A	783 nF	817 nF
\tilde{A} (Models 111 & 112)	9 A	500 Hz	8.83	9.17
$\overline{\tilde{A}}$ (Models 111 & 112)	5 A	0 Hz	4.047	5.053
	-5 A		-4.047	-5.053
	9 A		8.88	9.12

1 Does not include test lead resistance.

Calibrating the Meter

To enable Calibration mode

1. Turn the rotary switch to the \tilde{V} position.
2. Using a small blunt probe, press and hold the recessed calibration button for one second. The recessed calibration button is located under the calibration seal on the back of the Meter.

The Meter beeps once and then enters Calibration mode. When Calibration mode is enabled, the Meter displays the calibration step number on the display unless you press one of the alternate calibration keys. The Meter remains in Calibration mode until it is switched off, or until the calibration sequence is completed and you press the yellow **Hz** button.

The buttons behave as follows when you enable Calibration mode:

Table 3. Calibration Options

Button	Calibration Option
HOLD	Press and hold the HOLD button to display the measured value.
MINMAX	Press and hold the MINMAX button to display the required input.
RANGE	Press the RANGE button to skip the present calibration step without accepting the input signal. If you skip a calibration step, it may invalidate the calibration.
Hz	Press the yellow Hz button to accept the input signal, calibrate the function and start the next step. The Hz button is also used to exit Calibration mode after the calibration sequence is complete.

Note

*The measured value shown on the display may not be accurate during calibration. If the rotary knob setting does not correspond with the requested calibration step, then the present measurement will be invalid. Even if the rotary knob is in the correct position, the present measurement (reported when the **HOLD** button is pressed and held) is likely to be slightly different from the applied signal because it will be showing an uncalibrated measurement.*

To calibrate the Meter

1. Turn the rotary switch to the desired calibration function. (See the calibration settings later in this document for the list of functions.)

Note

If the rotary switch position is wrong when the calibration step is completed, the Meter beeps twice and you will be unable to continue with the calibration process.

2. Apply the input signal required by the present calibration step. Press and hold the **MINMAX** button to view the required value on the display.
3. Wait for the measurement to settle out to its final value. Press and hold the **HOLD** button to view the measured value on the display.

Note

This is an uncalibrated measurement, so it is likely to be slightly inaccurate. This is normal.

4. Press the yellow **Hz** button to proceed to the next step. The Meter records a new constant.
5. Repeat steps 1 through 4 until the display shows “End”. This indicates that the calibration procedure is complete. Press the yellow **Hz** button to resume normal operation, or switch the Meter off.

Calibration Settings

Note

The “Seconds to settle” column does not include calibrator settling time.

Table 4. Calibration Settings for the Fluke 110

Step Number	Function (switch position)	Input value	Frequency (sine wave)	Seconds to Settle
C-01	\widehat{V} - Hz	6.000 V	900.0 Hz	4
C-02	\widehat{V}	6.000 V	60 Hz	2
C-03	$\overline{\overline{V}}$	6.000 V	DC	1
C-04	Ω)	600 Ω	N/A	1
C-05	Ω	6.000 k Ω	N/A	1

Table 5. Calibration Settings for the Fluke 111 and 112

Step Number	Function (switch position)	Input value	Frequency (sine wave)	Seconds to Settle
C-01	\widehat{V} - Hz	6.000 V	900.0 Hz	4
C-02	\widehat{V}	6.000 V	60 Hz	2
C-03	$\overline{\overline{V}}$	6.000 V	DC	1
C-04	Ω)	600 Ω	N/A	1
C-05	Ω	6.000 k Ω	N/A	1
C-06	$\overline{\overline{A}}$ (use Amps jack)	6.000 A	DC	1

Display Messages

If the calibration procedure is not completed correctly, the Meter will not operate correctly. If calibration is not completed correctly, the Meter alternates the messages “CaL” and “Err” on the display and you will need to recalibrate the Meter. The meter is damaged and requires service if:

- “CaL” and “Err” messages continue to appear after a proper recalibration.
- “EEPr” and “Err” messages are alternating on the display.
- “EEPr” message appears on the display.

Cleaning the Meter

⚠ Warning

To avoid electrical shock or damage to the Meter, never allow water inside the case. To avoid damaging the housing, never apply solvents to the Meter.

- Periodically wipe the case with a damp cloth and mild detergent. Do not use abrasives or solvents.
- Dirt or moisture in the input terminals can distort meter readings. Clean the terminals as follows:
 1. Turn the rotary switch to **OFF** and remove the test leads from the terminals.
 2. Shake out any dirt that may be in the terminals.
 3. Soak a new swab with alcohol. Clean each terminal with the swab.

User-Replaceable Parts

User-replaceable parts are shown in Table 6.

Table 6. User Replaceable Parts

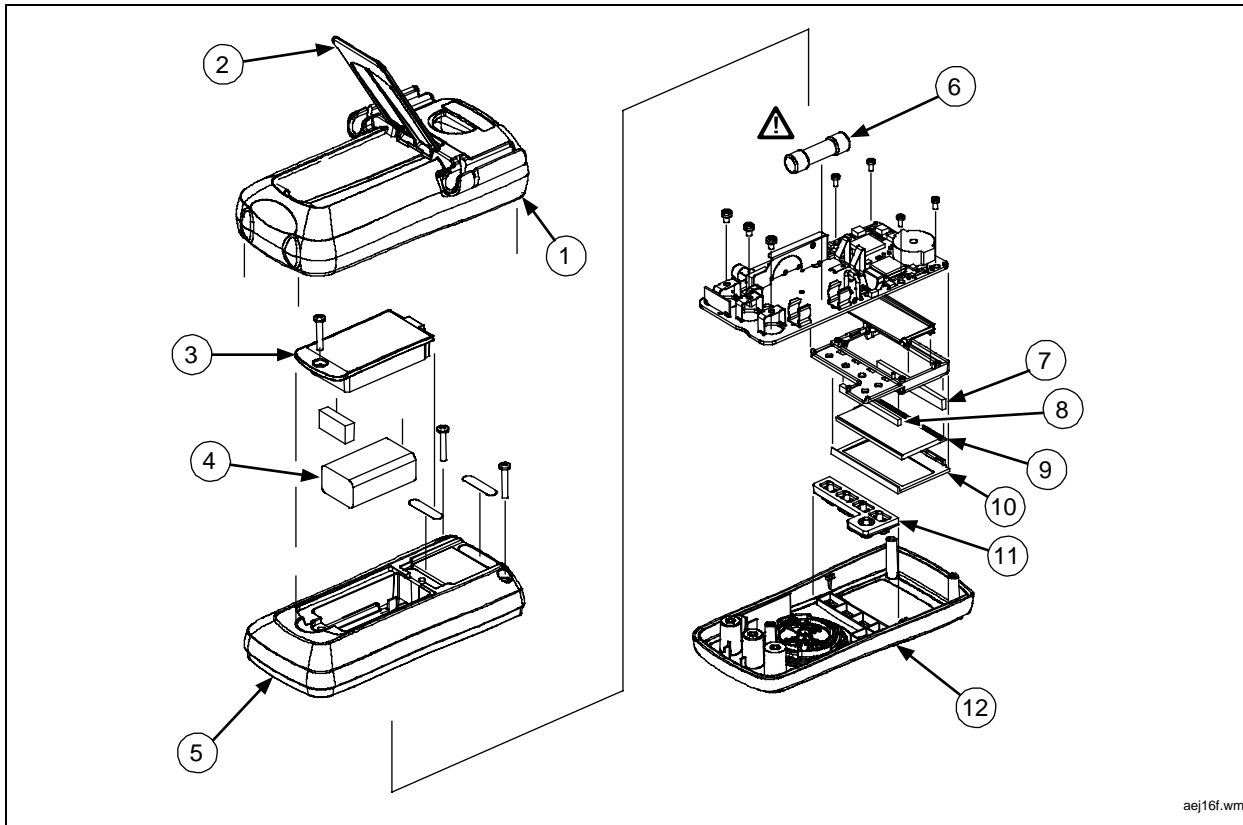

aej16f.wmf

Item	Description	Part No
1	Holster	1579321
2	Tilt stand	1566954
3	Battery door	1572523
4	9 V Alkaline battery, ANSI 1604A/IEC 6LR61	614487
5	Case bottom	1566946
6	 F1 Fuse, 11 A, 1000 V, FAST - Minimum interrupt rating 17,000 A (Models 111 and 112)	803293
7	Elastomeric connector	1569475
8	Rubber spacer	1568778
9	LCD	1555497
10	LCD mask (Model 110)	1567724
	LCD mask (Model 111)	1567713
	LCD mask (Model 112)	1580678
11	Keypad (Models 110 and 111)	1566794
	Keypad with backlight button (Model 112)	1566782
12	Case top (Model 110)	1608241
	Case top (Model 111)	1608234
	Case top (Model 112)	1608229

 To ensure safety, use exact replacement only.