

# **HOBO<sup>®</sup> U30 Station Remote Communication User's Guide**

**Models: U30-GSM, U30-C3G, U30-WIFI, U30-ETH**

### Contacting Onset

For support, please contact the company that you bought the products from: Onset Computer Corporation or an Onset Authorized Dealer.

Onset Computer Corporation  
470 MacArthur Blvd.  
Bourne, MA 02532

**Mailing Address:**

P.O. Box 3450  
Pocasset, MA 02559-3450

**Phone:** 1-800-LOGGERS (1-800-564-4377) or 508-759-9500

**Fax:** 508-759-9100

**Customer Service Hours:** 8AM to 5PM Eastern Time

**Technical Support Hours:** 8AM to 8PM Eastern Time

**Email:** loggerhelp@onsetcomp.com or hobolink@onsetcomp.com

**Main Onset Web site:** www.onsetcomp.com

### Copyrights and Trademarks

© 2009–2014 Onset Computer Corporation. All rights reserved. Onset, HOB0, HOB0link, HOB0ware, BoxCar, and FlexSmart are trademarks or registered trademarks of Onset Computer Corporation for its data logger products and configuration/interface software. Macintosh is a registered trademark of Apple, Inc. Microsoft and Windows are registered trademarks of Microsoft Corporation. All other trademarks are the property of their respective companies.

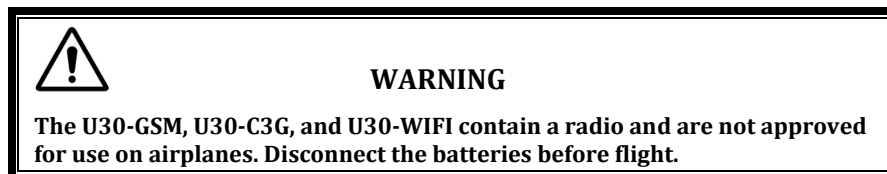
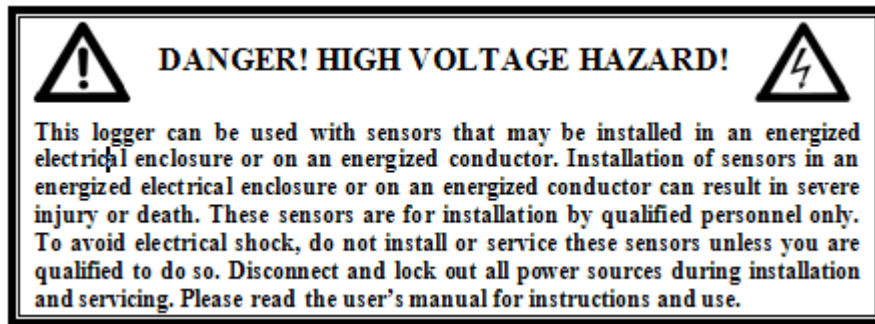

## Contents

<b>About the HOBO U30 Station.....</b>	<b>1</b>
Introduction .....	1
Key Features .....	2
U30 Station Components .....	3
Software.....	5
Smart Sensors.....	6
The Analog Sensor Port.....	7
<b>Setup and Test .....</b>	<b>9</b>
Configuration Summaries.....	9
Initial HOBOLink Setup.....	11
Initial Hardware Setup .....	12
Connecting the HOBO U30 Station to HOBOWare .....	13
Configuring Analog Sensor Ports or a TRMSA Module.....	14
Changing the State of the U30 Relay Contact .....	16
Basic Hardware Setup.....	17
Final HOBOLink Setup and Test.....	18
Installing Mounting Plates .....	19
Connecting Smart Sensors .....	20
Connecting Analog Sensors.....	22
Connecting the Battery.....	23
<b>Network Settings .....</b>	<b>24</b>
Configuring Wireless Network Settings .....	24
Configuring a Static IP Address.....	28
<b>Installing the U30 Station in the Field.....</b>	<b>30</b>
Field Installation Procedure.....	30
Connecting Grounding Wire.....	32
Installing Weatherproof Cable Channels .....	33
Connecting Solar or AC Power.....	36
Connecting Equipment to the Relay Contact.....	37
Mounting the HOBO U30 Station to a Pole .....	38
Checking Cellular Signal Strength .....	39

<b>The U30 Relay Contact .....</b>	<b>40</b>
An Overview of the U30 Relay Contact .....	40
Relay Example - Start Device .....	42
Relay Contact Example - Stop Device .....	43
Configuring Relay Alarms for the U30/RC .....	44
Changing the State of the U30 Relay Contact .....	45
Configuring Relay Alarms for the U30/RC .....	46
<b>Maintenance.....</b>	<b>47</b>
General Maintenance.....	47
Adding a Sensor .....	49
Removing/Replacing a Sensor .....	50
Testing Smart Sensors .....	50
Checking the U30 Status .....	50
Inspecting the HOBO U30 Station .....	51
Troubleshooting the HOBO U30 Station .....	52
<b>The Smart Sensor Expander Board.....</b>	<b>54</b>
Opening the Secondary Cable Slot .....	54
Installing the Expander Board.....	56
<b>The Battery .....</b>	<b>58</b>
Overview.....	58
Battery Life .....	59
Maximizing Battery Life .....	60
Battery Voltage .....	61
Connecting the Battery .....	62
Maintaining the Battery .....	63
Replacing the Battery .....	63
Troubleshooting the Battery .....	64
Battery Life without External Power .....	65
<b>Reference.....</b>	<b>66</b>
General U30 Specifications .....	66
Cellular/Wi-Fi Specifications .....	68
Analog Sensor Port.....	69
Time Accuracy.....	71

Memory .....	72
Connection Status LEDs .....	73
Logger Status LEDs.....	75
Items Required for Field Installation.....	76
Accessories .....	77
FCC Part 15 Compliance.....	78
Wi-Fi Compliance.....	79
Ethernet Compliance .....	80
<b>Tripod Setup .....</b>	<b>81</b>
Guidelines for Typical Field Setup .....	81
Field Preparation Checklist .....	83
Items Required for Installation.....	84
Task 1: Assemble Tripod .....	86
Task 2: Install Grounding Kit .....	93
Task 3: Temporarily Install Upper Mast (Optional) .....	94
Task 4: Mount Cross Arm (Optional).....	95
Task 5: Mount Upper Mast to Lower Mast .....	96
Task 6: Mount Logger to Upper Mast .....	97
Task 7: Install Guy Wire Kit (Optional).....	98
Task 8: Position and Level Sensors .....	99
Task 9: Final Setup .....	100

# ABOUT THE HOBO U30 STATION

## Introduction

---

### Overview

The HOBO U30 Station is a data logging and monitoring device that can be easily reconfigured and adapted to a wide variety of applications. Up to 15 channels of data can be recorded and monitored remotely via HOBOLink®.

Use HOBOWare® software to set up analog data channels, communicate with the logger locally, and perform advanced plotting and analysis.

The HOBO U30 Station is a data logging system that can be easily reconfigured and adapted to a wide variety of applications. Up to 15 channels of data can be recorded and monitored with HOBOWare software.

You can set alarms to trip for specific sensor readings that you select or for overall system conditions, such as when the memory or battery is running low.

### Remote Communication Models

The HOBO U30 Station is available in three models that support Remote Communication:

- Cellular
- Wi-Fi
- Ethernet

**Note:** The HOBO U30/Wi-Fi works with all approved Access Point Router standards including typical home IEEE 802.11b and IEEE 802.11g units. Pre-N and Draft-N access point routers are 'preliminary' and may not work with the HOBO U30/Wi-Fi.

### Contents

The HOBO U30 Station package includes:

- HOBO U30 Station
- Mounting Kit
- Grounding Wire
- Cable Entry and Sealing Kit
- Optional Analog Sensor Port, if ordered
- Optional Sensor Expander Board, if ordered

## Key Features

---

### Remote Communication

There are three versions of the U30 that allow for remote communication using HOBOLink. By using any web browser, you can configure and view data from the HOBO U30 Station anywhere in the world.

- Cellular. The HOBO U30-GSM and U30-C3G contains a communications radio module that uses the mobile phone network to establish an internet connection with HOBOLink.
- Wi-Fi. The HOBO U30-WIFI combines ruggedized data logging hardware with integrated Wi-Fi communications, and is versatile enough to use in both indoor and outdoor environments. Users can easily and quickly plug in their choice of sensors and connect to a Wi-Fi network without having to worry about cumbersome communications cables or wiring.
- Ethernet. The HOBO U30-ETH allows you to connect directly to the internet using an Ethernet cable.

### Automatic Detection of Smart Sensors

The HOBO U30 Station automatically recognizes Smart Sensors. You can connect up to 10 Smart Sensors of any type or combination just by plugging them in before logging begins. No programming, wiring or calibration is required to set them up. The connections between the Smart Sensors and the logger are digital, ensuring accurate, reliable data collection and storage. The HOBO U30 Remote Monitoring System is compatible with all Smart Sensors used with the HOBO Weather Station and HOBO Micro Station.

### Alarm Notification

The HOBO U30 Station supports alarm notification for sensors as well as system alarms. When an alarm is detected, the system can trigger the relay contact closure and send you a notification to your email/mobile phone. Alarms can be set for individual sensors and for overall system conditions.

### Rechargeable Battery

The HOBO U30 Station uses a Sealed Lead Acid battery that can be recharged via a solar panel or AC adapter. This provides continuous power to keep the HOBO U30 Station recording and transmitting data for years.

### Optional Analog Sensor Ports

The HOBO U30 Station can be optionally configured with two analog sensor ports. The ports are user-configurable and can accept and provide excitation power to a wide range of Onset and third-party sensors with 0-20 V or 0-20 mA output. The Analog sensor ports are factory-installed.

## U30 Station Components

This topic describes the components for the HOB0 U30 Station. Some components apply to specific models only, as noted.

### Diagram

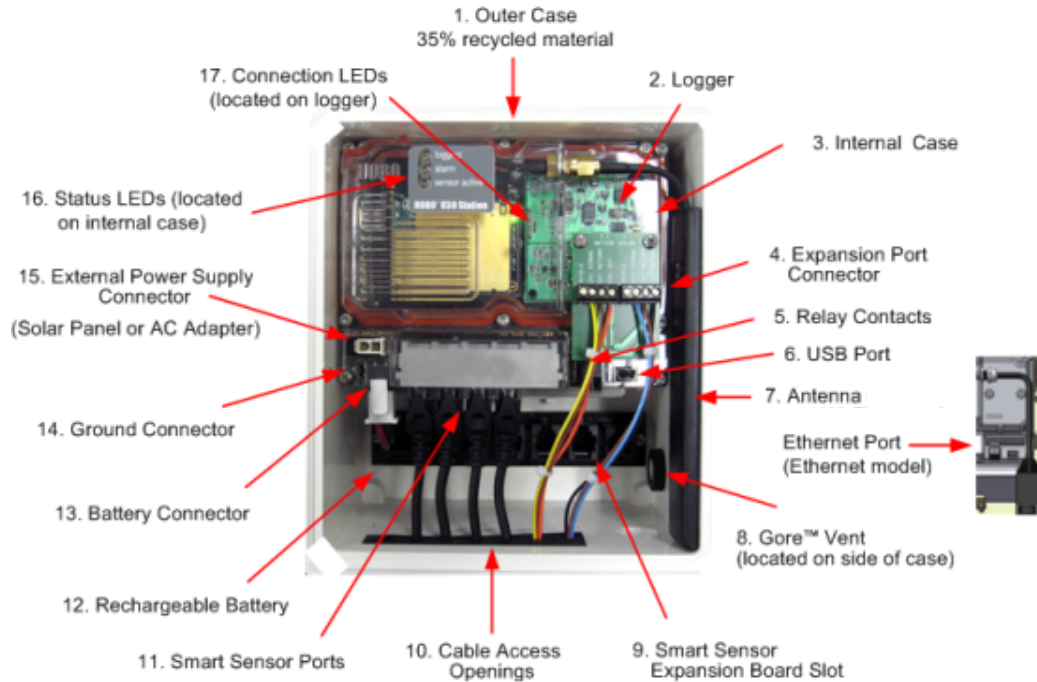

Figure 1: U30 Components

### Component Descriptions

1. Outer Case - Protects the U30 Station.
2. Logger - The U30 Station.
3. Internal Case – This weatherproof case provides a second level of protection for the U30 electronic circuitry. Do not open this case; doing so will void the warranty.
4. Expansion Port Connector (shown with optional Analog Sensor Port installed) - This port is where the optional Analog Sensor Ports are factory-installed.
5. Relay Contacts - The Relay can be activated, deactivated, or pulsed on user-defined sensor alarms. The relay can be configured as normally open or normally closed, and is rated for 30 V, 1 Amp maximum.
6. USB Port - Plug in a USB cable here to connect directly to a computer.
7. Antenna or Ethernet Port - Antenna installed on cellular or Wi-Fi models; Ethernet Connection for the Ethernet model only.
8. Vent - This vent allows pressure to equalize inside the enclosure, but does not allow liquid to pass through.



**NOTE:** The pressure inside the case does not match the outside air pressure exactly so a barometric pressure sensor deployed within this case cannot measure the true atmospheric pressure unless it has its own unrestricted vent to the outside.

9. Smart Sensor Expansion Slot - The optional Smart Sensor Expander Board is installed here.
10. Cable access openings - All cables and wires are pulled through a protective rubber cable channel placed in this opening. If using the optional factory-installed expander board for additional Smart Sensors, you will need to use the second cable access opening.
11. Smart Sensor Ports - Connect up to five Smart Sensors in these RJ-12 jacks. Use one jack to connect the optional expander board for additional Smart Sensors.
12. Rechargeable Battery - 4-Volt Sealed Lead Acid (SLA) battery located inside the case.
13. Battery Connector - Plug in the 4-Volt Sealed Lead battery here.
14. Ground Connector - Plug in grounding wire here to ground the system.
15. External Power Supply Connector - Plug in the compatible solar panel or AC adapter here.

**Important:** Always connect or disconnect external power before the battery. Damage may occur if the battery is unplugged before the external power is disconnected.

16. Status LEDs

There are three Light Emitting Diode (LED) status indicators.

**Logging** indicates whether the system is currently logging.

**Alarm** indicates if an alarm has been tripped.

**Sensor active** indicates that Smart Sensor network communications are occurring.

For more information on LEDs, refer to Diagnostics and troubleshooting.

17. Connection LEDs (Remote Communication Models only)

Top - Blinks when the HOB0 U30 Station is attempting to contact a network (cellular tower, Wi-Fi, or Ethernet, depending on model).

Bottom - Blinks when the U30 is connected to HOBOLink.

## Software

---

The HOBO U30/RC Station is designed primarily for use with HOBOLink, which allows for continuous logging and transmission of data using remote communication technology. There is some configuration however that requires HOBOWare software. Before you set up your system, it is important to understand when to use HOBOLink and HOBOWare.

### HOBOLink

- Launching the U30 Station
- Setting up readout schedules (connection intervals)
- Configuring Alarms
- Viewing Data
- Monitoring Status

See the *HOBOLink Help* for details.

### HOBOWare

- Configuring the Analog Sensor Ports
- Changing the default system-wide relay operation (which is normally open)
- Testing individual Smart Sensors
- Plotting and analysis of datafiles
- Troubleshooting when there is no connection to HOBOLink

See the *HOBOWare User's Manual* for details.

## Smart Sensors

---

### Description

Smart sensors plug into the logger and collect data about various parameters.

The HOB0 U30 Station automatically recognizes Smart Sensors. You can connect up to 10 Smart Sensors of any type or combination just by plugging them in before logging begins. No programming, wiring or calibration is required to set them up. The connections between the Smart Sensors and the logger are digital, ensuring accurate, reliable data collection and storage.

You do not have to stop the logger to add a new Smart Sensor. Simply connect the sensor and then select *Force Relaunch on Next Connection* in the **Launch Configuration** panel in HOB0link.

Refer to [www.onsetcomp.com](http://www.onsetcomp.com) for a current list of available sensors.

### Cable Length

The HOB0 U30 Station can work with a maximum total of Smart Sensor cable lengths up to 100 meters (328 feet), as measured from the logger connection point to the electronics embedded in the individual cables. Optional Smart Sensor extension cable lengths must also be included in the total. This limitation applies to Smart Sensor cables only. The lengths of other cables, such as those connected to the Analog Sensor Port or the analog portion of smart sensor cables do not need to be included in this total.

### Data Channel Limitations

The HOB0 U30 Station can log up to 15 data channels (not including the internal battery channel). This includes the two channels in the Analog Sensor Port plus each of the Smart Sensor channels (note that some Smart Sensors may have more than one channel). If you have more than 15 channels connected, some of the sensors will be ignored. You should remove any Smart Sensors that will not be used in the deployment, and disable the second channel in the Analog Sensor Port if it is not needed (the first channel cannot be disabled). If you connect a Smart Sensor that has multiple channels (such as temperature and relative humidity), all of its channels will be logged. There is no way to disable them.

## The Analog Sensor Port

---

The Analog Sensor Port is an easy-to-configure, flexible DC signal-conditioning option that can be factory-installed in the HOBO U30 Station. This two-channel port can accept, and provide excitation power to a wide range of Onset and third-party sensors with 0–20 V or 0–20 mA output, including devices with 4–20 mA current loop interface, and sensors with 0–2.5, 0–5, and 0–10 V DC output.

The Analog Sensor Port features input protection and signal filtering, as well as delta-sigma A/D conversion and factory calibration. This port features extremely low power operation, resulting in long battery life for unattended data logging applications. Precision electronics provide  $\pm 0.25\%$  accuracy from 50 mV to full scale (FS).

Sensors connected to this Analog Sensor Port can be configured using HOBOWare. Configuration options include scaling parameters, and excitation power. See page 14, as well as the *HOBOWare User's Manual* for configuration details.

If your HOBO U30 Station does not have an Analog Sensor Port and you wish to upgrade to one, contact Onset Computer Corporation for information.

### Sensor Excitation

The Analog Sensor Port supports optional, user-configurable sensor excitation power and warm-up. Sensor excitation is a voltage output provided by the HOBO U30 Station to power a sensor that is connected to it. This power may be needed because the sensor is not self-powered, or because the sensor's power capacity cannot support a long deployment.

When sensor excitation is required, the logger can provide 12 V DC sensor excitation voltage up to 50 mA total for transducers that require external power for proper operation. The excitation voltage has a programmable warm-up time and is controlled by the Analog Sensor Port.

Excitation power can affect the battery life. If your sensor does not require it, you should not include it in the channel configuration.

### Modes

Carefully select the sensor excitation mode that best meets your needs.

- Warm-up mode

The logger supplies excitation power for a brief, user-programmable period prior to each measurement. This mode allows you to select the minimum warm-up time needed to allow for sensor stabilization, while conserving battery power.

For example, if you specify a warm-up of one second and set the Logging Interval to one minute, the HOBO U30 Station will power the external sensor for one second, log a measurement, and then turn off the excitation power for the next 59 seconds.

The warm-up time can be set from 5 milliseconds up to 120 seconds.

**NOTE:** If the warm-up time selected is greater than the logging interval selected, the logger will interpret the excitation mode as continuous.

- Continuous mode

The logger supplies constant excitation power to the sensor for the entire duration of the deployment. This mode will result in reduced battery life. Continuous mode is required if the sensor needs more than two minutes of warm-up time. The Analog Sensor Port begins functioning when logging begins.

When the ports are functioning correctly, the Active indicator LED on the port blinks once per logging interval to indicate that a successful measurement has been made. The **Ex. On** indicator LED will also be lit when excitation is enabled.

# SETUP AND TEST

## Configuration Summaries

---

This topic summarizes different paths you should take for HOBOLink and hardware configuration depending on your U30 Station model and optional configuration you may need to perform. These are not all of the possible scenarios, but the actual procedures will guide you through any other variations you may have.

The hyperlinks below will open in a new window, so you will always be able to reference this topic while you are viewing the detailed procedures.

### Cellular

#### U30-GSM or U30-C3G Station with no Analog Sensors

[Initial HOBOLink Setup \(page 11\)](#)

[Basic Hardware Setup \(page 17\), Steps 1-4](#)

[Final HOBOLink Setup and Test \(page 18\)](#)

### Wi-Fi

#### U30-WIFI Station with DHCP and no Analog Sensors

[Initial HOBOLink Setup \(page 11\)](#)

[Basic Hardware Setup \(page 17\), Steps 1-3](#)

[Configuring Network Setup \(page 24\), Steps 1-3](#)

[Basic Hardware Setup \(page 17\), Step 4](#)

[Final HOBOLink Setup and Test \(page 18\)](#)

#### U30-WIFI Station with Static IP and no Analog Sensors

[Initial HOBOLink Setup \(page 11\)](#)

[Basic Hardware Setup \(page 17\), Steps 1-3](#)

[Configuring Network Setup \(page 24\), Steps 1-3](#)

[Basic Hardware Setup \(page 17\), Step 4](#)

[Final HOBOLink Setup and Test \(page 18\)](#)

### U30-WIFI with DHCP and Analog Sensors

- Initial HOBOLink Setup (page 11)
- Basic Hardware Setup (page 17), Steps 1-3
- Configuring Network Setup (page 24), Steps 1-3
- Configuring Analog Sensor Ports or TRSMA Module (page 14), Steps 3-5
- Basic Hardware Setup (page 17), Step 4
- Final HOBOLink Setup and Test (page 18)

### Ethernet

#### U30-ETH Station with Static IP and no Analog Sensors

- Initial HOBOLink Setup (page 11)
- Basic Hardware Setup (page 17), Steps 1-4
- Configuring a Static IP Address (page 28)
- Final HOBOLink Setup and Test (page 18)

#### U30-ETH Station with Static IP and Analog Sensors

- Initial HOBOLink Setup (page 11)
- Basic Hardware Setup (page 17), Steps 1-3
- Configuring a Static IP Address (page 28)
- Configuring Analog Sensor Ports or TRSMA Module (page 14), Steps 3-5
- Basic Hardware Setup (page 17), Step 4
- Final HOBOLink Setup and Test (page 18)

## Initial HOBOLink Setup

---

Before you connect the battery to the U30 Station, you should perform this procedure to setup your HOBOLink account and perform initial configuration and testing for the U30.

For more details, see the *HOBOLink Help*.

### Steps

1. Go to [www.hobolink.com](http://www.hobolink.com) and create a HOBOLink account.
2. Activate your account by responding to the Activation e-mail.
3. Log into your HOBOLink account and register the U30 that you are configuring.
4. Configure the *Logging Interval* in the **Launch Configuration** pane.

For an initial test, configure a *Logging Interval* just long enough to record data that you can verify. You will later change this to you required interval for deployment.

5. Configure the *Connection Interval* in the **Readout Configuration** pane.

For this test, you may want to configure a frequent Connection Interval so that you can verify proper operation without having to wait as long for updates. For the U30-GSM or U30-C3G, this will be limited by the Fastest Connection Allowed by your Communication Plan. To bypass your Communication Plan restrictions for testing, see below.

Once you confirm the readouts are occurring as they should, you can change the Connection Interval to your desired on-going schedule for deployment.

**NOTE:** For testing, you can bypass your Communication Plan restrictions by manually connecting to HOBOLink using HOBOWare (direct connection using supplied USB Cable). From the main menu select **Status**, and then click the **Contact HOBOLink** button. After the test, disconnect the U30 from the computer. The U30 will connect to HOBOLink at the next scheduled **Connection Interval**.

**NEXT TASK:** Initial Hardware Setup (page 12).



# Initial Hardware Setup

---

Before you take the U30 Station into the field for deployment you should perform the following preliminary hardware assembly and configuration:

- Basic Setup (Required)
- Network Settings (U30 Wi-Fi and Ethernet) (Optional)
- Analog Sensor Ports or TRMS Module (TRMSA-D)(Optional)

Everyone must perform Basic Hardware Setup first. Follow the procedure from there if you need to configure Network Settings or Analog Sensor Ports/TRMS Module.

## Before you Begin

This procedure assumes that you have already created a HOBOLink account and registered the U30 Station. You should register the U30 Station before you connect the battery and have it connect to HOBOLink. See Initial HOBOLink Setup on page 11.

## Items for Setup

### If you are using the Smart Sensor Expander Board

- Smart Sensor Expander Board
- Expander cable
- Bladed screwdriver or chisel and a file for removing cover of Secondary Cable Bay

### If you are using Analog Sensors or Relay Contact

- Small flat-head screw driver

**Start Here:** Basic Hardware Setup (page 17)

## Connecting the HOB0 U30 Station to HOB0ware

---

This topic describes the procedure for connecting the HOB0 U30 Station to HOB0ware. For the HOB0 U30/RC, you need to use HOB0ware to configure Analog Sensor Ports/TRMSA Modules and to change the Relay Contact setting.

1. Connect to a computer.

To connect to a computer running HOB0ware, plug the “mini-USB” end of the USB cable provided into the USB port on the HOB0 U30 Station and connect the “A” end to the USB port in your computer.

**Important:** If the USB cable is connected to the HOB0 U30 Station at power up, it will not make an immediate connection to HOB0link.com. This allows you to use HOB0ware without requiring you to override a connection to HOB0link. If a connection with the HOB0 U30 Station is not initiated by HOB0ware within 10 minutes, it will attempt to connect to HOB0link automatically.



Figure 2: Connecting the U30 to a computer

If the device has never been connected to this computer before, it may take some time for the computer to detect the new hardware and report that it has connected successfully. One or more messages will appear, indicating that new hardware has been found. You may also hear a chime.

**NOTE:** Your computer may tell you to reboot before you can use the device. It is not necessary to reboot.

2. Run HOB0ware.
3. From the **Device** menu select **Select Device ....**
4. In the **Select Device** pane, click in the circle next to the desired device name and then click **OK**.

When the device is recognized by HOB0ware, the status bar at the bottom of the HOB0ware window will show the connection status.

## Configuring Analog Sensor Ports or a TRMSA Module

---

This is a branch of the Basic Hardware Setup procedure (page 17) for those who need to configure Analog Sensor Ports or a TRMSA Module.

**NOTE:** If you need to configure network settings for the U30-WIFI or the U30-ETH and have not already, you should first perform Configuring Network Settings procedure on page 24.

### Steps

If you are coming to this procedure from the Basic Hardware Setup procedure (page 17), start at Step 1.

If you are coming to this procedure from the Configuring Network Settings procedure (page 24), start at Step 3.

1. Connect the U30 Station to a computer using the USB cable (page 13).
2. Connect the Battery (page 62).

**NOTE:** As long as your battery has adequate charge, you do not need to connect the solar panel or AC adapter for this initial setup/test launch.

3. Launch HOBOWare.
4. From the Device menu, select Configure Modules/Ports.  
If the logger is already logging, you will be warned that the logger will have to be stopped first.

The **Select Channel to Configure** dialog will appear showing all configurable Analog Sensors attached to the logger.

5. Click on the + sign to expand the entry and show the channels.

Each channel in the module is defined by its channel number (the physical order in the module), the configured channel name, and any location (assigned at launch) defined for this channel in the logger.

**NOTE:** The default channel names Voltage and Current are just place holders and either channel can be configured to measure voltage or current. For example, both channels can be used to monitor sensors with 4-20 mA output.

6. Select a channel name and then click the Configure button to open the **Channel Configuration** dialog.
7. Change any relevant configurable parameters. Refer to the *HOBOWare User's Guide* for more details on this topic.
8. Save the Configuration (Optional). To send the currently displayed configuration to the module/port, click **Configure**. The module will remain in this configuration until you send it a different configuration.
9. Disconnect the USB cable from the U30 Station.
10. Reset the U30 Station by cycling power.

11. Disconnect the battery from the U30 Station and then reconnect it to cycle power.

The U30 Station will connect to HOBOLink at the next Connection Interval. Proceed to Final HOBOLink Setup and Test (page 18).

## Changing the State of the U30 Relay Contact

The U30 relay contact is a latching relay that can be configured as either *Normally Open* or *Normally Closed*. The factory-default setting is *Normally Open*. You can change the default relay settings in the **Alarm** dialog in HOBOWare.

### Steps

This procedure assumes the U30 Station is connected to a computer running HOBOWare.

1. From the **Device** menu, select **Manage U30**, and then **Configure U30 Alarms** to open the **Alarms** window.
2. In the **Relay Contacts** section, select *Normally Open* or *Normally Closed*.

Alternate Method: From the **Device** menu, select **Manage U30**, then select **Control U30 Relay > Set Default (Deactivated) State** and then select either *Open* or *Closed*.

3. If you are setting an **Alarm Action** of *Pulse Relay*, you can set the **Relay Pulse Width**. The default is 1 s.
4. Click **Set** to send the alarm configuration to the U30 Station.
5. To test the relay, click the **Close Relay** or **Open Relay** button (button that appears depends on which state the relay is in). You should hear a click in the HOBO U30 Station. Click the button again to return to the default state. Use a digital multimeter to check for continuity to confirm that the relay is opened and closed as expected.

Alternate Method: From the **Device** menu, select **Manage U30**, then select **Control U30 Relay > Activate Relay**, then select *Deactivate Relay*.

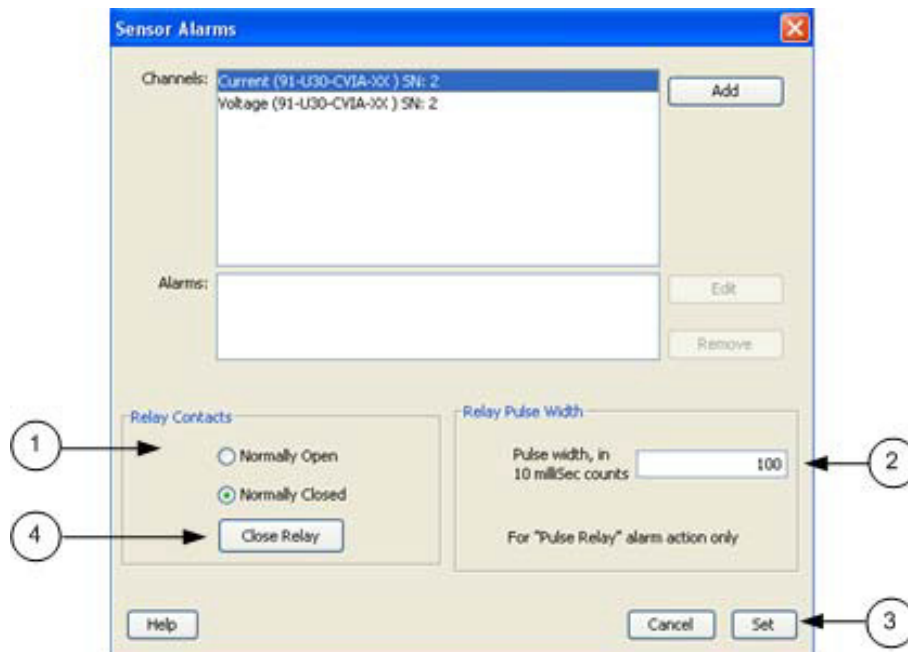

Figure 3: Testing the Relay

## Basic Hardware Setup

---

Everyone must perform this basic hardware setup procedure first. If you need to configure Network Settings or Analog Sensor Ports, follow the Procedure Branch in the procedure as required for your U30 Station configuration.

### Steps

1. Open Secondary Cable Slot (if applicable)

If a Smart Sensor Expander Board was factory-installed and you will be using those ports now, you must open the Secondary Cable Slot. See page 54 for details.

If you are installing the Expander Board yourself, do that after you remove the secondary cable slot. See page 56 for details.

2. Install Mounting Plates (page 19).
3. Connect Smart Sensors (page 20) and Analog Sensors (page 22).

Onset recommends that you test all sensors you plan to deploy with the logger.

**NOTE:** If you are using the Solar Radiation Shield, set up the Temperature and Temperature/RH sensors. There are several small pieces required to connect these sensors to the shield that could easily get lost in the field. It is strongly recommended you install these sensors in the solar radiation shield before going to the field. See the Solar Radiation Shield Manual for more information.

### Procedure Branch

#### Option 1

If you need to configure Wireless Network Setup for the U30-WIFI or U30-ETH, proceed to Configuring Wireless Network Settings (page 24).

#### Option 2

If you do not need to configure Wireless Network Setup but you do need to configure Analog Sensor Ports, proceed to Configuring Analog Sensor Ports (page 14).

#### Option 3

If you do not need to:

- configure Wireless Network Setup for the U30-WIFI or U30-ETH, or
- configure Analog Sensor Ports

Continue with this procedure.

4. Connect Battery (page 62)

**NOTE:** As long as your battery has adequate charge, you do not need to connect the solar panel or AC adapter for this initial setup/test launch.

The U30 Station will connect to HOBOLink at the next Connection Interval.

Proceed to Final HOBOLink Setup and Test (page 18).

# Final HOBOLink Setup and Test

---

This topic describes the final HOBOLink setup and system test.

## Before You Begin

This procedure assumes that you have completed the Initial HOBOLink Setup (page 11) and Initial Hardware Setup (page 12).

## Steps

1. If you are not logged into HOBOLink, log into HOBOLink now.
2. Perform additional HOBOLink configuration if required (Label Sensors, Configure Alarms). See the *HOBOLink Help* for details.
3. Check the Device Status and the graphs to verify that sensors are reporting correctly and the HOBO U30 Station is being readout properly.
4. When you are satisfied that the HOBO U30 Station and HOBOLink are working properly, change your *Logging Interval* and *Connection Interval* to your desired settings for deployment.
5. Repack the logger and sensors for transit.

Onset strongly recommends that you use the original packaging when possible because it is custom-designed to protect the weather station and its components.

**NEXT TASK:** Installing the U30 Station in the Field (page 28).

## Installing Mounting Plates

---

Screw the mounting plates onto the back of the HOBO U30 Station case using a Phillips-head screwdriver. Be careful to orient the plates as shown below so that the screw heads are sunk into the screw holes.

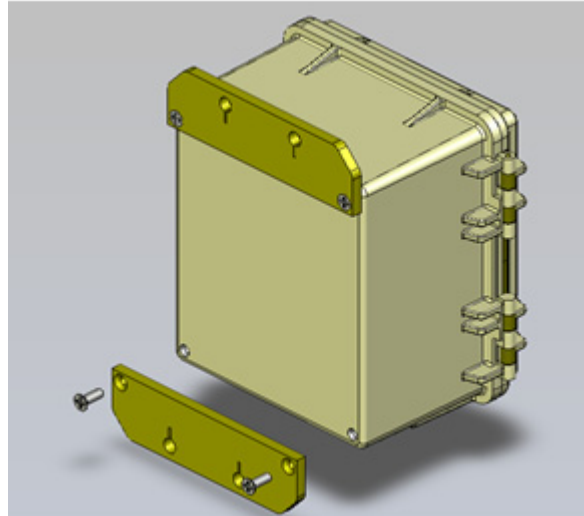

Figure 4: Installing Mounting Plates



# Connecting Smart Sensors

---

## Before You Begin

- Connect Smart Sensors before you begin logging with the U30. Smart Sensors plugged in after logging has already begun will be ignored.
- This procedure assumes that the Smart Sensor Expander Board and connector are already installed. See page 54 for information.

## Steps

**NOTE:** If you are using the Smart Sensor Expander Board, connect sensors to those ports first.

1. Run cables through the Secondary Cable Slot.

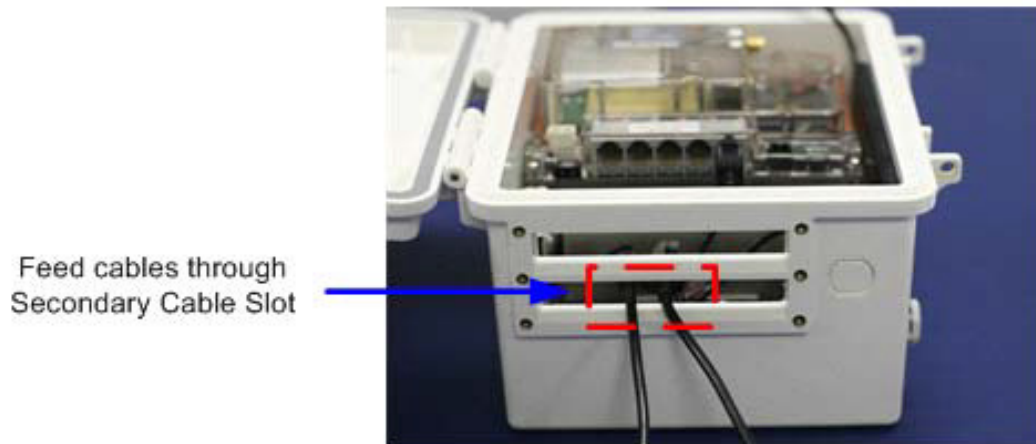

Figure 5: Run Cables through Secondary Slots

2. Plug the cables into the Smart Sensor Expander Board.

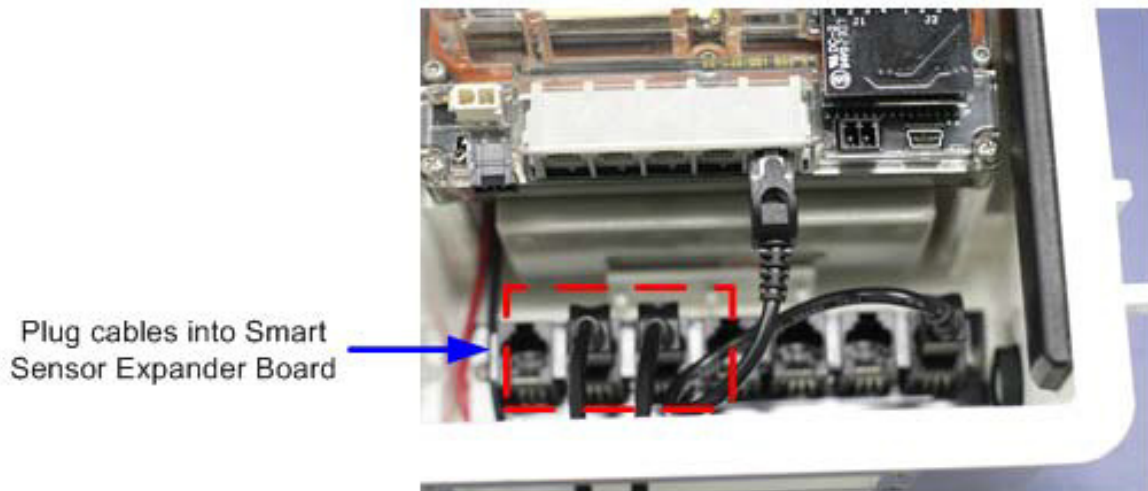

Figure 6: Plug cables into Expander Board

3. Run cables for remaining Smart Sensors through the Primary Cable Slots and connect the cables into the Primary Smart Sensor Ports.

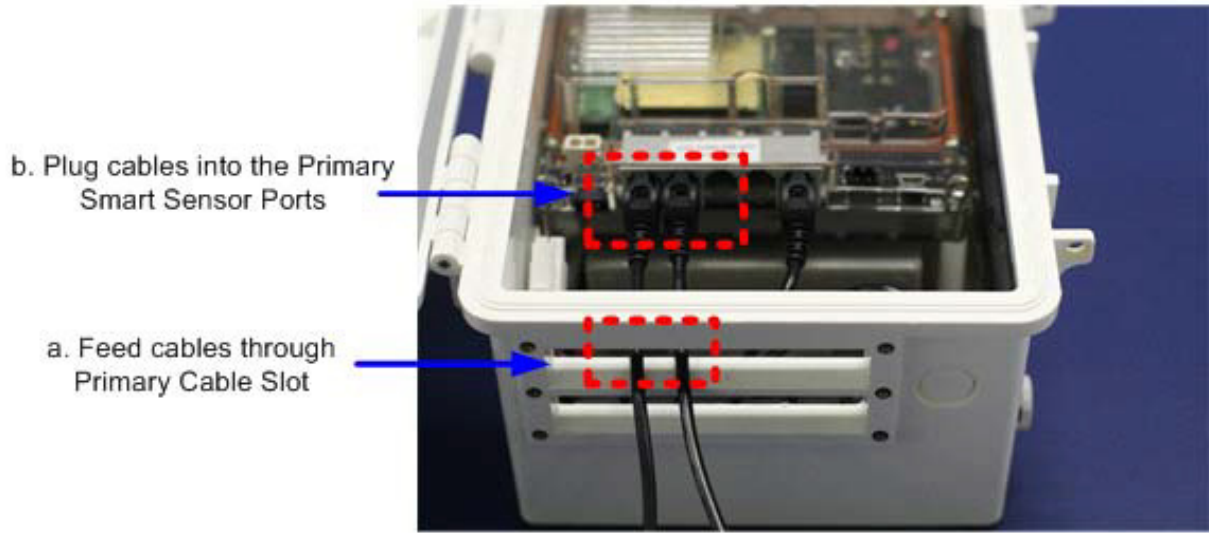

Figure 7: Plug Cables into Primary Slot

**Note:** Smart sensors are listed in ascending order by serial number in HOBOWare and HOBOLink by default.

## Connecting Analog Sensors

---

Refer to the specific sensor documentation for terminal connection details and use the pinout diagram on page 69 to connect a two- or three-wire sensor or transducer to the module's terminals.

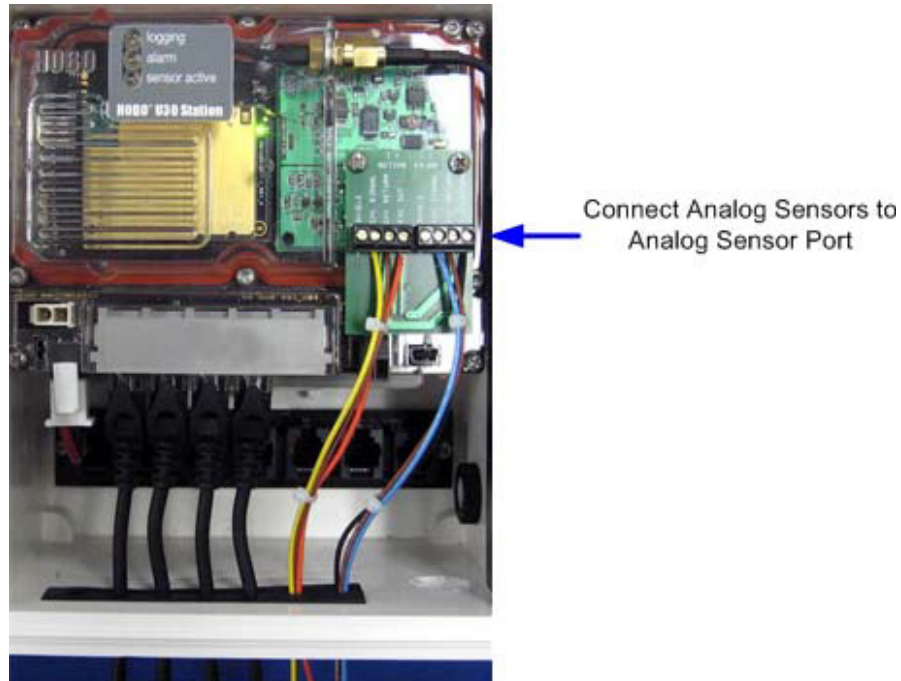

Figure 8: Connecting Analog Sensors

### Steps

To make the connection:

1. Loosen the screw for each pin on the connector.
2. Insert the appropriate wire, which should be trimmed to 0.25 inches,  $\pm 0.04$  inches of bare wire exposed.

Make sure all wires attached to the Analog Sensor Port are routed through the cable access opening.

3. Tighten the screw.

### Note on Cables

To fit into the holes in the rubber cable channel, the ideal cable diameter is 0.157 in (4.0 mm). If the cable is too small, build up the diameter using heat shrink. If it is too big and you are using the secondary cable access opening, then place the cable through the left-most hole in the rubber cable channel where the diameter can be up to 0.25 in (6.4 mm).

If you are not using the secondary opening or the cable is still too big, then splice on another cable with a smaller diameter to fit through the hole. See the steps later in this section for working with the rubber cable channel.

## Connecting the Battery

---

This topic illustrates how to connect the battery to the U30 Station.

### Before You Begin

**NOTE:** You should not connect the battery until you have performed Initial HOBOLink Setup (page 11).

### Illustration

Connect the built-in battery cable to the battery as shown below.

**WARNING:** Do not plug in battery here. This is for the solar panel or optional AC adapter.

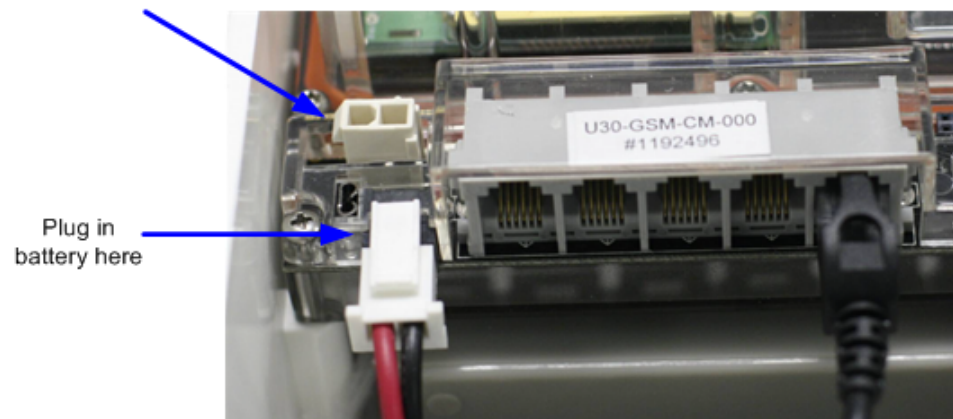

Figure 9: Connecting the Battery

# NETWORK SETTINGS

## Configuring Wireless Network Settings

---

This is a branch of the Basic Hardware Setup procedure (page 17), for those who need to configure wireless network (WLAN) settings for the U30-WIFI. Note that you will need to change the settings every time you access a different wireless network.

**IMPORTANT:** If you are not familiar with network configuration, consult with your Network Administrator or IT Department.

### Steps

1. **Download the HOBO NetSetup utility.** Go to this URL and click the HOBO Network tab to download the utility required for setting up your U30 Station to work with your wireless network: [http://www.onsetcomp.com/support/software\\_utilities](http://www.onsetcomp.com/support/software_utilities)

**Note:** The HOBO NetSetup Utility requires Microsoft .NET Framework (Version 4.0 or above) installed. To determine if you have this installed on your computer, go to Start > Control Panel > Add or Remove Programs to see if it is in the list of currently installed programs. A link to .NET is also located at the same location as the HOBO NetSetup utility.

2. **Run HOBO NetSetup.** Double-click the HOBO\_NetSetup.exe file to run the HOBO NetSetup utility.
3. **Connect the U30 Station.** Make sure the U30 is not powered (battery and/or AC adapter cables should be disconnected). Connect the U30 Station to the computer with the USB cable, then plug in the battery to power up the U30 Station. Click Begin in the HOBO NetSetup utility.

4. **Enter information about your Wi-Fi network.** Complete the Basic Networking and WIFI panels in the Network Configuration screen as explained below. If you are using a U30-ETH, you only need to fill in the Basic Networking panel.

The screenshot shows a 'Network Configuration' window with the following sections:

- Device Information:** MAC Address: 00204A9F7371
- Basic Networking:**
  - DHCP:  Enabled,  Disabled
  - IP Address: [ ] . [ ] . [ ] . [ ]
  - Netmask: [ ] . [ ] . [ ] . [ ]
  - Gateway: [ ] . [ ] . [ ] . [ ]
- WIFI:**
  - Network name (SSID): linksys
  - Security Suite: WEP
  - Encryption Type: WEP128
  - Encryption Key Type:  Passphrase,  Hex
  - Leave Encryption Key empty to re-use the last saved key. The current key will not be displayed for security.
  - Encryption Key: [ ]
  - Encryption Key Index: 1
  - Authentication Key: shared

Buttons: Apply, Quit

**All fields are case sensitive**

### ***Basic Networking***

By default, DHCP is set to Enabled, which is frequently used for small wireless networks. If your network uses static IP addresses, set DHCP to Disabled and enter the following:

- IP Address: Use a unique address in the network.
- Gateway Address: The gateway address, or router, allows communication to other LAN segments. The gateway address should be the IP address of the router connected to the same LAN segment as the unit and it must be within the local network.
- Netmask: The netmask defines the number of bits taken from the IP address that are assigned for the host part.

**Note:** The unit's configuration is stored in nonvolatile memory and is retained without power. You can change the configuration at any time. The unit performs a reset after the configuration has been changed and stored.

### ***WIFI***

You will need the network name, password, and settings to add the U30-WIFI to your network (you do not need to configure these settings for a U30-ETH model; click Apply

and continue to the next step). Consult your IT department for assistance, or if you are running your own network, refer to your router documentation for how to access this information.

- Network Name: Type in the exact name, or SSID, of your wireless network (this is case-sensitive).
- Security Suite: Select the security suite used by your network: None, WEP, WPA, or WPA2/802.11i. **Note:** WPA2/802.11i is compliant with the Robust Secure Network that is specified in the IEEE standard 802.11i. It enables the AES-based strong CCMP encryption.
- Encryption Type: Based on the security suite you selected, choose the appropriate encryption type.

Security Suite Chosen:	Options for Encryption Type:
None	None
WEP	WEP64 or WEP128 When using WEP, you must also set <ul style="list-style-type: none"> <li>▪ Encryption Key Index (1, 2, ,3, or 4)</li> <li>▪ Authentication Key (open/none or shared)</li> </ul>
WPA	TKIP or TKIP+WEP
WPA2/802.11i	CCMP, CCMP+TKIP, CCMP+WEP, TKIP, TKIP+WEP

- Encryption Key Type. Select either Passphrase (password) or Hex.
  - Encryption Key. Type in your passphrase (password), which is case-sensitive, or the hex values. If you previously set up an encryption key with this utility, you can leave the field empty to re-use the same one or enter a new one if it has changed. Note that the encryption key is never displayed in this window for security purposes.
5. Click Apply to save the network settings to the U30 Station.
  6. Click Quit to close HOB0 NetSetup.
  7. If you need to configure Analog Sensor Ports or a TRMSA Module, proceed to Step 3 of Configuring Analog Sensor Ports (page 14). Otherwise, disconnect the USB cable and cycle the power on the U30 Station (disconnect the battery and then reconnect it). The U30 Station will connect to HOB0link at the next Connection Interval. Proceed to Final HOB0link Setup and Test (page 18).

### Notes about Wireless Network Security

Without adequate protection, a wireless LAN is susceptible to access by unauthorized users. The U30-WIFI features the WPA security standard, based on IEEE802.11i and IEEE802.1X. WEP is provided for backwards compatibility and interaction with older devices.

When in WPA and WPA2 modes, the encryption setting denotes the lowest acceptable encryption method. CCMP is higher than TKIP and TKIP is higher than WEP. For example, if the U30-WIFI is configured for WEP and the access point supports TKIP, the negotiation results the use of TKIP. If the U30-WIFI is configured for TKIP and the access point supports only WEP, the association will fail since the access point does not meet the WiPort's requirements.

Unicast communication occurs between the access point and a single wireless device. It uses the pairwise encryption method. Multicast communication occurs between the access point and multiple wireless devices. It uses the group encryption method. The group encryption for all wireless devices communicating with the same access point must be equal in order to receive broadcast and multicast messages. If any device is WEP-only (i.e. no support for WPA), set the encryption to TKIP+WEP.

To use higher security with the U30/Wi-Fi than other devices connecting to the same access point, use a group encryption lower than the pairwise encryption.



## Configuring a Static IP Address

---

**IMPORTANT:** You do not need to perform this procedure unless your network uses static IP addresses. If you are unsure consult with your Network Administrator.

If you need to assign a static IP address to the U30 WiFi/Ethernet, use Onset's NetSetup utility to perform the procedure below. If you are not familiar with network configuration, have your Network Administrator or IT Department perform the procedure.

### Steps

1. **Download the HOBO NetSetup utility.** Go to this URL and click the HOBO Network tab to download the utility required for setting up your U30 Station to work with your wireless network: [http://www.onsetcomp.com/support/software\\_utilities](http://www.onsetcomp.com/support/software_utilities)

**Note:** The HOBO NetSetup Utility requires Microsoft .NET Framework (Version 4.0 or above) installed. To determine if you have this installed on your computer, go to Start > Control Panel > Add or Remove Programs to see if it is in the list of currently installed programs. A link to .NET is also located at the same location as the HOBO NetSetup utility.

2. **Run HOBO NetSetup.** Double-click the HOBO\_NetSetup.exe file to run the HOBO NetSetup utility.
3. **Connect the U30 Station.** Make sure the U30 is not powered (battery and/or AC adapter cables should be disconnected). Connect the U30 Station to the computer with the USB cable, then plug in the battery to power up the U30 Station. Click Begin in the HOBO NetSetup utility.

4. **Disable DHCP and enter information on the static IP address.** Under the Basic Networking Panel, select Disabled to turn off DHCP.

The screenshot shows the 'Network Configuration' window. It is divided into three main sections: 'Device Information', 'Basic Networking', and 'WIFI'.  
 - **Device Information:** MAC Address is 00204A9F7371.  
 - **Basic Networking:** DHCP is currently set to 'Enabled'. There are radio buttons for 'Enabled' (selected) and 'Disabled'. Below are input fields for IP Address, Netmask, and Gateway, each with four boxes for digits.  
 - **WIFI:** Network name (SSID) is 'linksys'. Security Suite is 'WEP'. Encryption Type is 'WEP128'. Encryption Key Type has radio buttons for 'Passphrase' (selected) and 'Hex'. There is a text field for 'Encryption Key' with a warning: 'Leave Encryption Key empty to re-use the last saved key. The current key will not be displayed for security.' Below that is an 'Encryption Key Index' dropdown set to '1' and an 'Authentication Key' dropdown set to 'shared'. A note at the bottom states 'All fields are case sensitive'.  
 - At the bottom are 'Apply' and 'Quit' buttons.

Enter the following:

- IP Address: Use a unique address in the network.
- Gateway Address: The gateway address, or router, allows communication to other LAN segments. The gateway address should be the IP address of the router connected to the same LAN segment as the unit and it must be within the local network.
- Netmask: The netmask defines the number of bits taken from the IP address that are assigned for the host part.

- 5 **Click Apply to save the network settings to the U30 Station.**
- 6 **Click Quit to close HOBOLink NetSetup.** If you need to configure Analog Sensor Ports or a TRMSA Module, proceed to Step 3 of Configuring Analog Sensor Ports (page 14). Otherwise, disconnect the USB cable and cycle the power on the U30 Station (disconnect the battery and then reconnect it). The U30 Station will connect to HOBOLink at the next Connection Interval. Proceed to Final HOBOLink Setup and Test (page 18).

# INSTALLING THE U30 STATION IN THE FIELD

## Field Installation Procedure

---

### Tools Required

Before you head into the field, refer to the Items Required for Installation topic on page 76 to make sure you have the necessary tools and equipment.

### Before You Begin

When deploying a HOB0 U30-GSM or U30-C3G Station, it is important to select a location where a cellular signal is strong to ensure regular connections to HOB0link. Check your cellular carrier's coverage map on their website to get a general idea of strong signal areas. Then, use HOB0ware to identify how strong the cellular signal is in the exact spot where the U30 Station is located. See *Checking Cellular Signal Strength* on page 39.

### Steps

This procedure assumes that you have performed the preliminary hardware setup and configuration and have performed a pre-deployment test.

1. Mount the HOB0 U30 Station.

If you are mounting the HOB0 U30 Station to a tripod, see *Tripod Setup* (page 84).

If you are mounting the HOB0 U30 Station to a pole, see *Mounting the U30 Station to a Pole* (page 38).

2. Connect the grounding wire (optional) (page 32).
3. Plug all Smart Sensors into the HOB0 U30 Station (if not already plugged in) making sure all cables are routed through the cable access opening(s) (page 20).
4. Connect Analog Sensors to the Analog Sensor Port, if applicable (page 22).

**NOTE:** It may be necessary to build-up the diameter third-party sensors with heat-shrink or electrical tape to match the diameter of the holes in the rubber cable channels and ensure a weather-tight seal.

5. Run the cable for a solar panel or AC adapter through the Primary Cable Slot, but do not connect it yet.
6. Install the weatherproof cable channel (page 33).
7. Connect the battery (page 23).
8. Connect the solar panel or AC adapter (page 36).
9. Verify that the HOB0 U30 Station powers up properly.
10. (Optional) Check Cellular Signal Strength.

If you are installing a U30-GSM or U30-C3G and you are unsure if you have adequate signal strength, you can check the signal strength using HOBOWare. See Checking Cellular Signal Strength on page 39.

11. Close the door and snap the hinges shut on the HOBOWare U30 Station case.

Consider using padlocks to secure the case. The system should begin operating as configured.

## Connecting Grounding Wire

---

You should connect the grounding wire if you are using the Wind Speed (S-WSA-M003) and/or Wind Direction Smart Sensors (S-WDA-M003) or if you are installing the HOBO U30 Station on a roof or in a location with exposure to lightning.

The grounding wire may also be helpful in reducing sensor errors when installing the HOBO U30 Station near other radio or electrical equipment or antennas.

Insert the grounding wire through the opening and plug it into the ground connector.

**IMPORTANT:** When installing the weatherproof cable channel in the next section, make sure to place the black portion of the grounding wire into the sensor cable groove.

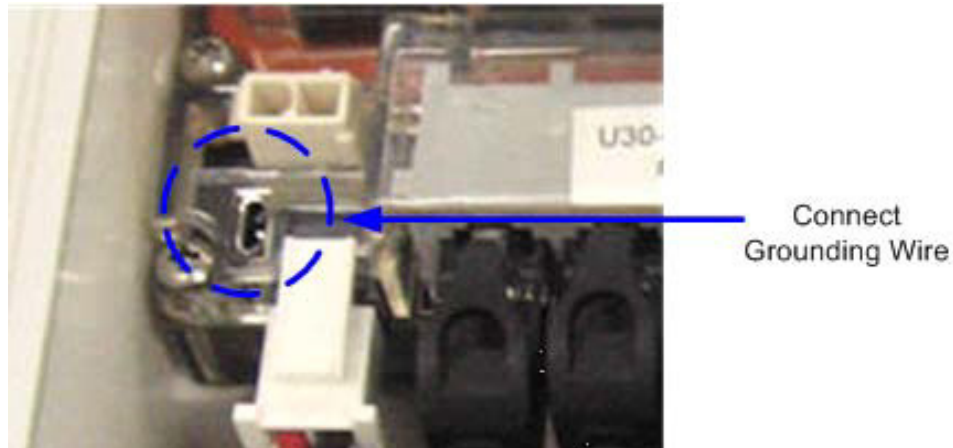

Figure 10: Connecting Grounding Wire

## Installing Weatherproof Cable Channels

---

**NOTE:** If you are doing a pre-deployment test setup, you do not need to install the weatherproof cable channel for the sensor cables if you are going to disconnect the sensor for transportation to the field.

### Guidelines

- All cables and wires should be routed through the cable access opening at this point.
- If you are using the Smart Sensor expander board, make sure those cables are routed through the secondary cable slot.

### Steps

1. Grease the Cable Channel.

Apply a small amount of silicone grease (about the size of a pea) onto your fingertip and then work a light coating into the top, bottom, and two ends (the sides with no holes) of the rubber cable channel. Also put a light coating on the inside of the two halves of the cable channel.

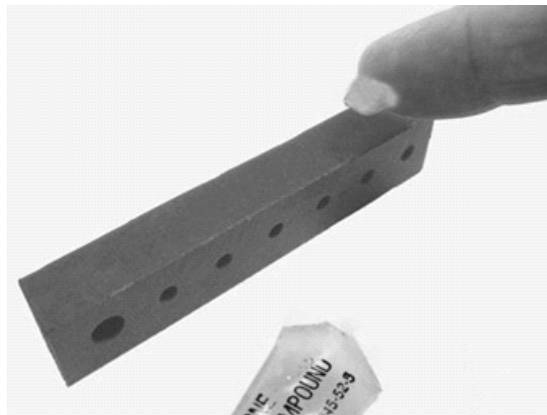

Figure 11: Grease Cable Channel

2. Place Cables in Channel.

a. Hold the channel just below the HOBO U30 Station case (with the channel's hinged side on the left and the taper facing in).

b. Open the channel and lay the cables and wires into the grooves.

**NOTE:** The solar panel or AC adapter cable must be in the leftmost (larger diameter) groove.

**NOTE:** Use the small rubber plugs to fill any unused grooves. Center the thick part of the plugs in the groove. Plug 'tails' can face in or out. It may be easier to install these after the rubber cable channel has been pushed into the case. Insert the thin part of the plug into the hole and pull to center the thick part of the plug in the channel.

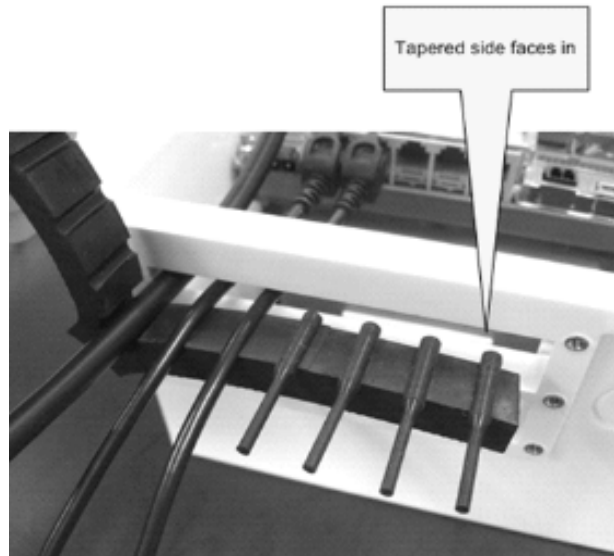

Figure 12: Place Cables in Channel

3. Press the Channel into the Case.

a. Close the channel, making sure the cables, wires, and any plugs remain in their grooves.

b. Press the channel into the opening.

To reduce the amount of excess cable in the case (especially when several Smart Sensors are connected), gently pull the cables toward you as you press the channel into place.

Press the channel in until it is flush with the outside of the case. (When fully seated, the channel will project slightly into the inside of the case.)

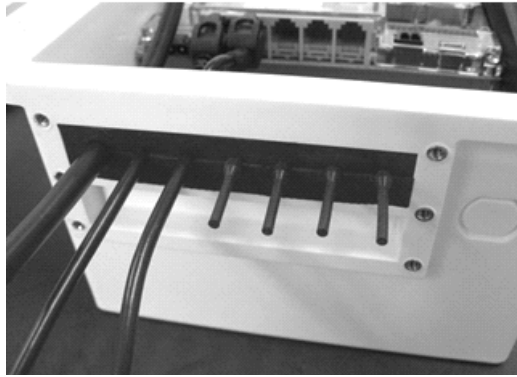

Figure 13: Press Channels into Case

4. Install Secondary Cable Channel (if applicable).

If you are using the Smart Sensor expander board, repeat these steps with the second cable channel. Use the larger plug for the leftmost hole if necessary.

5. Secure Channel Guide.

Finger-tighten the retaining bars on to the case to secure the channel(s). Do not use a screwdriver to tighten the thumb screws.

The bars should be flat against the case.

**NOTE:** After time, you may need a screwdriver to loosen them in the field.

Tighten knobs clock-wise

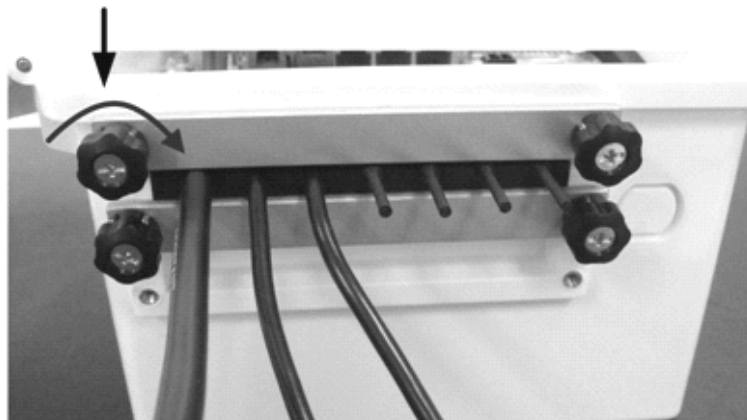

Figure 14: Secure Channel Guide



## Connecting Solar or AC Power

---

Connect a Solar Panel or AC Power, as shown below.

### IMPORTANT NOTES

- Make sure you run the cable through the Primary Cable Slot before you install the weatherproof cable channel.
- If at any point you need to unplug the battery, unplug the solar panel or AC adapter first. Damage may occur to the HOBO U30 Station if the battery is unplugged before disconnecting the solar panel or AC adapter.

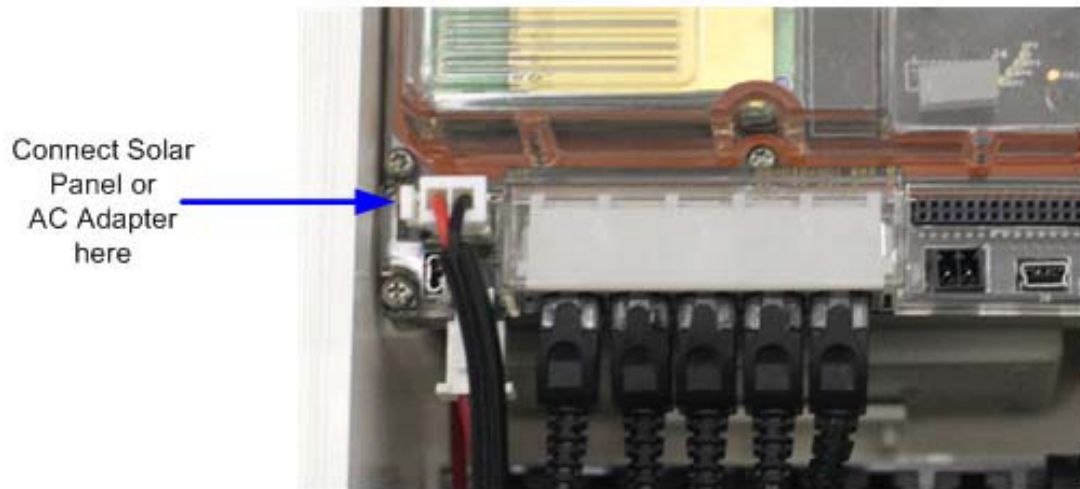

Figure 15: Connecting Solar or AC Power

## Connecting Equipment to the Relay Contact

---

Make sure any wire you use is routed through the cable access opening.

The diameter of the wire should be 4.0mm (0.159") if you are running it through a smart sensor opening, or 6.4 mm (0.25") if running it through one of the larger cable openings, which will require having the 10 sensor input option.

**NOTE:** These relays are only for low power switching (see specification for rating). To switch higher power, use an appropriately rated relay and use the U30 relay to switch the external relay on and off.

For more information see *The U30 Relay Contact* on page 40.

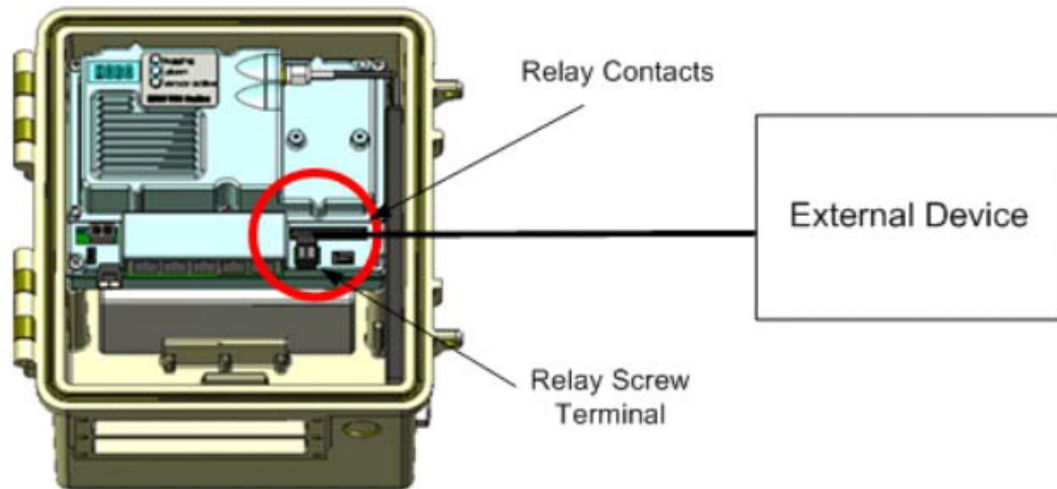

Figure 16: Connecting Equipment to Relay Contact

## Mounting the HOB0 U30 Station to a Pole

---

**NOTE:** If you are using the U30 Station as a component in the Remote Monitoring System, see Tripod Setup on page 81.

**Important:** For the U30-GSM or U30-C3G, all sensors should be mounted at least one foot from the HOB0 U30 Station case because the built-in radio module and antenna can cause interference with the measurements made by the sensors.

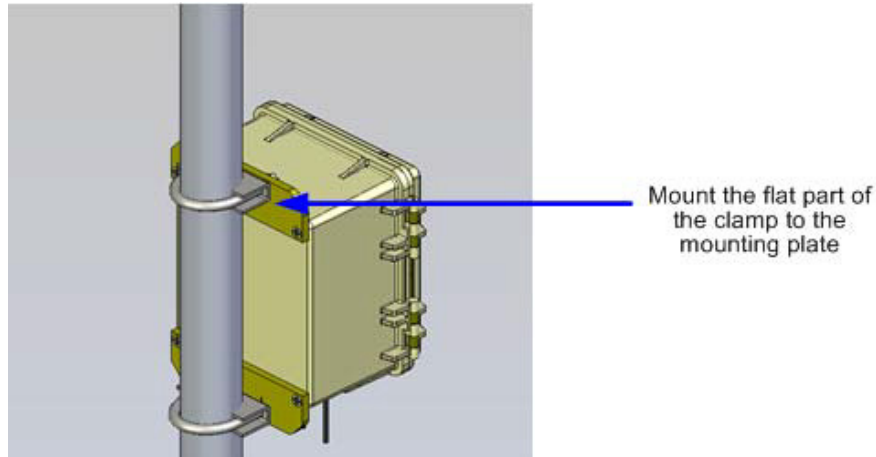

Figure 17: Mounting to a Pole

### Before You Begin

This topic assumes that you have already installed the mounting plates on the U30 Station (page 19).

### Guidelines

- Mount the HOB0 U30 Station vertically to a mast or pole using the U-bolts. Make sure the mounting plates are mounted against the flat part of the U-bolt saddle clamps.
- Mount the HOB0 U30 Station vertically to a wall or board using screws.
- If you are installing a grounding wire, make sure to run it through one of the sensor cable grooves.
- Make sure the HOB0 U30 Station remains in a vertical position once it is placed in its deployment location. If it is mounted horizontally, the battery could be damaged over time as it is charged and the antenna (U30-GSM, U30-C3G, and U30-WIFI) will not have optimal range.
- Any excess sensor cables should not be coiled up and stored inside or within one foot outside the case. The Leaf Wetness Smart Sensor (S-LWA) is especially sensitive and should be mounted at least two feet away from the case.

## Checking Cellular Signal Strength

---

When deploying the HOBO U30-GSM or U30-C3G Station, it is important to select a location where a cellular signal is strong to ensure regular connections to HOBOLink. Check your cellular carrier's coverage map on their website to get a general idea of strong signal areas. Then, use HOBOWare to identify how strong the cellular signal is in the exact spot where the HOBO U30 Station is located.

1. Connect the HOBO U30 Station to a computer using the USB cable.
2. Run HOBOWare.
3. Once the U30 is connected, select **Device > Status** to open the **Status** window and check the signal strength (RSSI) level.

Signal strength is measured on a scale of 0 to 10, with 0 being no signal and 10 being the strongest signal. Positioning the station in a location where the signal strength is 6 to 10 is ideal for consistent successful connections to HOBOLink.

4. Disconnect the computer from the U30 (make sure you remove the USB cable from the U30).

# THE U30 RELAY CONTACT

## An Overview of the U30 Relay Contact

---

Upon an alarm condition, the relay contact on the HOB0 U30 can be opened, closed, or pulsed to control the operation of an external device such as an irrigation system or fountain.

### To Stop a Device

If you have external equipment that you normally want running, you would set the **Deactivated State** of the relay to be *Closed*. You would set an alarm that, if tripped, would change the relay to the *Active State (open)* and the equipment would stop.

#### Equipment Normally On

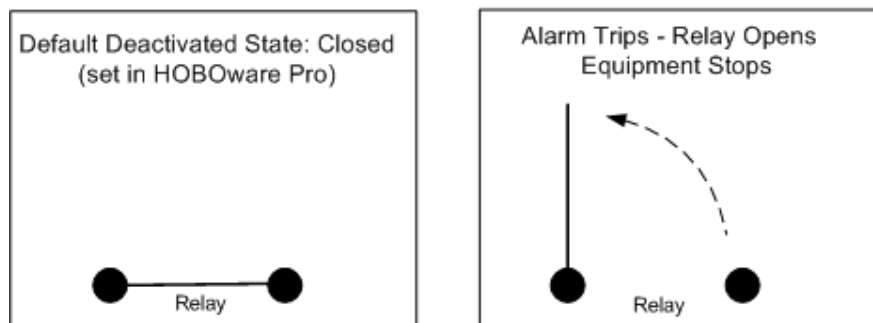

Figure 18: Equipment Normally On

See Relay Example - Stop Device.

### To Start a Device

If you have external equipment that you normally want off, you would set the **Deactivated State** of the relay to be *Open*. You would set an alarm that, if tripped, would change the relay to the *Active State (Closed)* and the equipment would start running.

#### Equipment Normally Off

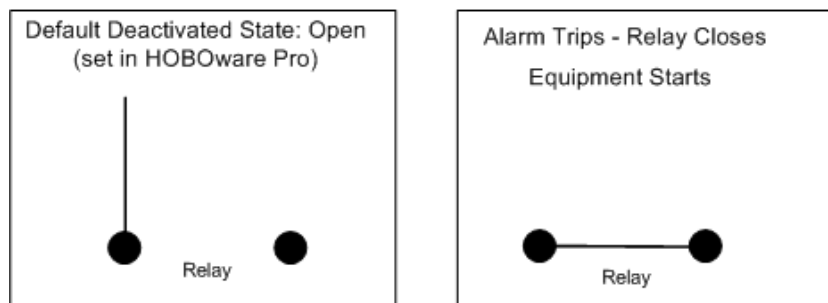

Figure 19: Equipment Normally Off

See Relay Example - Start Device.

## Pulse Relay

If you have an alarm configured with an **Action** of *Pulse Relay*, the relay will close briefly to activate a piece of external equipment and then open. For example, you would use this to take a water sample when water level reaches a certain amount. To use *Pulse Relay* the **Deactivated State** must be set to *Open*. The default duration is 1 second.

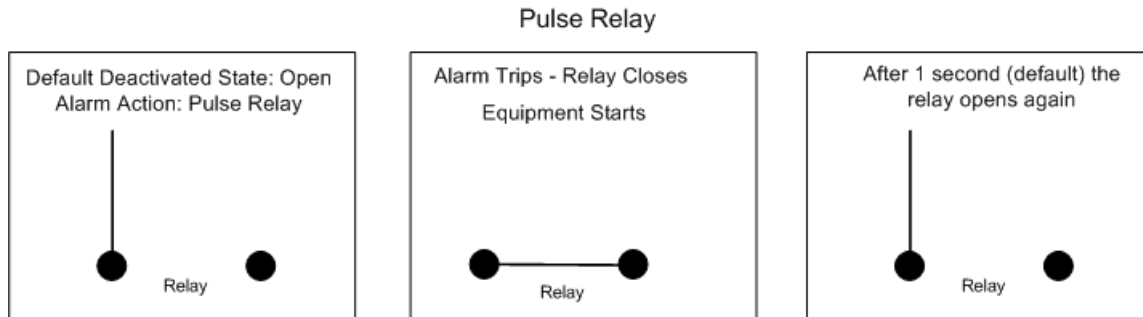

Figure 20: Pulse Relay

## Power Rating

The relay on the HOB0 U30 Station is rated for a maximum of 30 V, 1 Amp. If you need to switch higher power devices you will need to use an appropriate external relay that is controlled by the U30.

## Configuration

### Deactivated State

The **Deactivated State** is the normal state of the relay when no alarm has been tripped to activate the relay. You change the **Deactivated State** using HOB0ware.

### Alarm Action

Use HOB0link to configure an alarm to trigger the relay.

# Relay Example - Start Device

This example shows how you would configure the relay and alarms if you have an application where you have equipment you want turned on in response to an event. For example, if you wanted to activate an irrigation system on a cranberry bog or orchard if the temperature drops below a certain temperature to avoid frost damage.

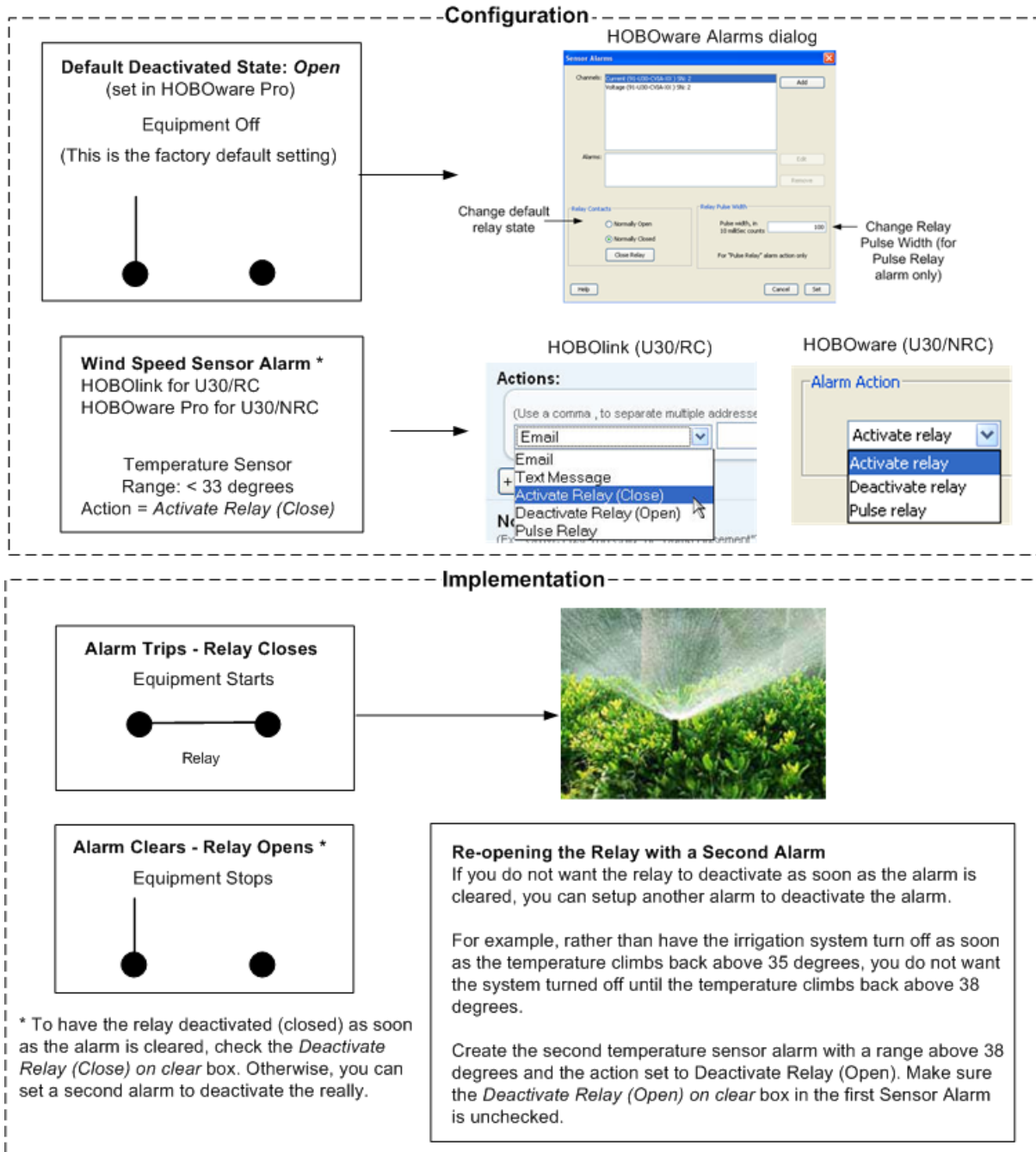

Figure 21: Relay Example - Start Device

# Relay Contact Example - Stop Device

This example shows how you would configure the relay contact and alarms if you have an application where you have equipment that is normally on. For example, if you have a fountain that normally runs continuously, but you want it to turn off if the wind speed exceeds 20 MPH.

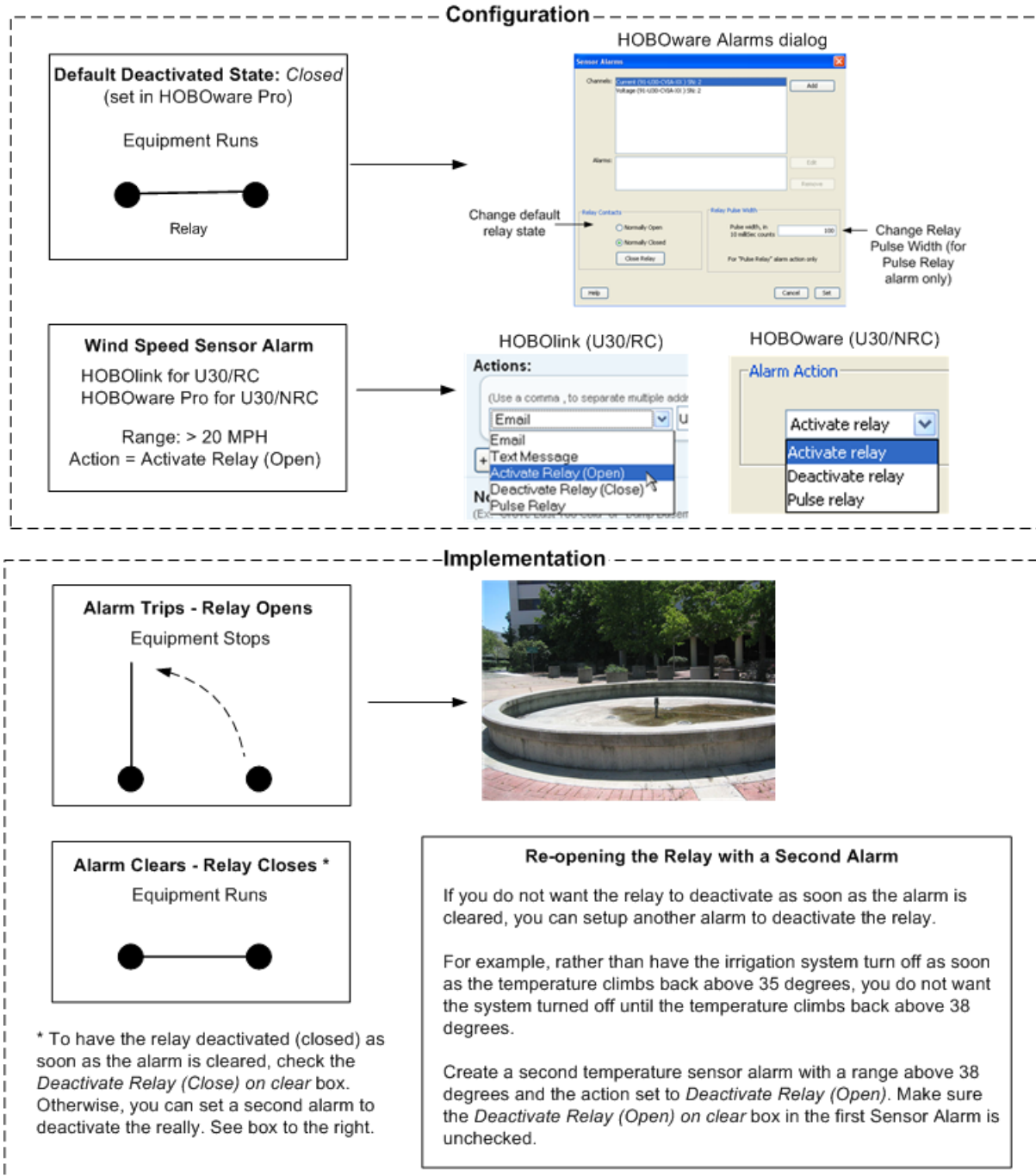

Figure 22: Relay Example - Stop Device



## Configuring Relay Alarms for the U30/RC

---

This procedure details the steps to configure an alarm to open or close the relay contact.

### Before You Begin

Make sure the default deactivated state is configured as required for your application and verify proper operation. See

Make sure the sensor is connected to the U30 Station.

### Closing a Normally Open Relay

1. Configure a sensor alarm for the desired sensor with required settings.
2. In the **Actions** section, select *Activate Relay (Close)*.
3. Test that an alarm activates the relay.

Force the sensor into an alarm condition (for example, place a temperature sensor in an ice bath) and verify that:

- E-mail and/or Text Messages are received for alarm
- Relay closes or opens as expected
- Relay State is properly reported in HOBOLink (after the U30 has connected to HOBOLink).

### Opening a Normally Closed Relay

If you have an application where you want the relay opened if an alarm trips (for example, to stop an irrigation system when rainfall is detected):

1. Using HOBOWare, change the **default (deactivated) state** to *Closed* (select Device > Manage U30 > Control U30 Relay > Set default (deactivated) state > Closed).
2. Using HOBOLink, configure a sensor alarm with an **Action** of *Activate Relay (Open)*. To have the relay deactivated as soon as the alarm is cleared, check the Deactivate Relay (Close) on clear box.

### Viewing the Relay State

You can view the current relay state in HOBOLink in the **Latest Conditions** pane of the **Device** window.

## Changing the State of the U30 Relay Contact

The U30 relay contact is a latching relay that can be configured as either *Normally Open* or *Normally Closed*. The factory-default setting is *Normally Open*. You can change the default relay settings in the **Alarm** dialog in HOBOWare.

### Steps

This procedure assumes the U30 Station is connected to a computer running HOBOWare.

1. From the **Device** menu, select **Manage U30**, and then select **Configure U30 Alarms** to open the **Alarms** window,
2. In the **Relay Contacts** section, select *Normally Open* or *Normally Closed*.

Alternate Method: From the **Device** menu, select **Manage U30**, then select **Control U30 Relay > Set Default (Deactivated) State** and then select either *Open* or *Closed*.

3. If you are setting an **Alarm Action** of *Pulse Relay*, you can set the **Relay Pulse Width**. The default is 1 s.
4. Click **Set** to send the alarm configuration to the U30 Station.
5. To test the relay, click the **Close Relay** or **Open Relay** button (button that appears depends on which state the relay is in). You should hear a click in the HOBOW U30 Station. Click the button again to return to the default state. Use a digital multimeter to check for continuity to confirm that the relay is opened and closed as expected.

Alternate Method: From the **Device** menu, select **Manage U30**, then select **Control U30 Relay > Activate Relay**, then select *Deactivate Relay*.

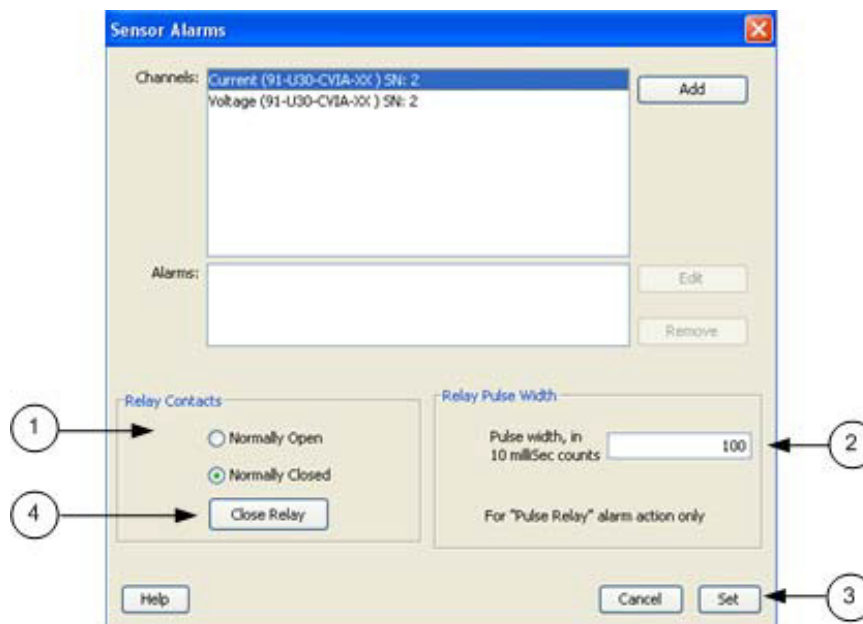

Figure 23: Testing the Relay

# Configuring Relay Alarms for the U30/RC

---

This procedure details the steps to configure an alarm to open or close the relay contact.

## Before You Begin

Make sure the default deactivated state is configured as required for your application and verify proper operation. See

Make sure the sensor is connected to the U30 Station.

## Closing a Normally Open Relay

1. Configure a sensor alarm for the desired sensor with required settings.
2. In the **Actions** section, select *Activate Relay (Close)*.
3. Test that an alarm activates the relay.

Force the sensor into an alarm condition (for example, place a temperature sensor in an ice bath) and verify that:

- E-mail and/or Text Messages are received for alarm
- Relay closes or opens as expected
- Relay State is properly reported in HOBOLink (after the U30 has connected to HOBOLink).

## Opening a Normally Closed Relay

If you have an application where you want the relay opened if an alarm trips (for example, to stop an irrigation system when rainfall is detected):

1. Using HOBOWare, change the **default (deactivated) state** to *Closed* (select Device > Manage U30 > Control U30 Relay > Set default (deactivated) state > Closed).
2. Using HOBOLink, configure a sensor alarm with an **Action** of *Activate Relay (Open)*. To have the relay deactivated as soon as the alarm is cleared, check the Deactivate Relay (Close) on clear box.

## Viewing the Relay State

You can view the current relay state in HOBOLink in the **Latest Conditions** pane of your device page.

# MAINTENANCE

## General Maintenance

---

### Remote Inspection

Use HOBOLink to make sure the HOBO U30 Station is operating as expected, data is still being recorded, and regular readouts are being completed.

### Physical Inspection

Onset recommends that you periodically visit the HOBO U30 Station to perform general maintenance and test sensors annually. Regular maintenance is essential to ensure the accuracy of recorded measurements.

Performing regular maintenance checks allow you to:

- Verify that the logger is logging data and functioning as you expect
- Identify damage
- Minimize the impact of any existing damage

For more information see "Inspecting the HOBO U30 Station".

### Checking the U30 Status

1. From the main menu go to **Device > Status** to open the Status window.

The **Status** window appears, showing the status of the logger and the attached sensors.

2. Verify Sensor Readings

Change the sensor readings by changing the conditions.

For example, if you are measuring temperature, hold the temperature sensor in your hands for a minute or two and verify that the temperature shown in the Current Readings increases.

3. Close the Status window by clicking OK.

### Verifying sensor accuracy

Onset recommends that you test most sensors for accuracy once a year using HOBOWare. For details on verifying sensor accuracy, refer to the documentation included with each sensor. For third-party sensors (even those supplied by Onset), refer to documentation provided by the manufacturer.

For a fee, Onset can verify the accuracy of a sensor. It may be possible to recalibrate some sensors. Contact Onset Technical Support for details.

## Cleaning the HOBO U30 Station

The HOBO U30 Station does not require specialized cleaning; however, if it is deployed in a dusty or grimy location, you should wipe it down with a damp cloth occasionally to keep it looking its best.

## Adding a Sensor

---

New sensors will only be recognized by the HOB0 U30 Station when it is not logging. If you attempt to add a sensor while the logger is recording data, it will be ignored. Logging will continue normally for all other sensors already plugged in. Note that sensors are listed in ascending order by serial number.

### Smart Sensors

To add new Smart Sensors:

1. Using HOB0ware, stop the logger from logging
2. Readout the data from the logger.

**IMPORTANT:** All existing data will be lost when you re-launch the logger.

3. Plug in any new Smart Sensors.
  4. Re-launch the logger. The new Smart Sensors should start recording measurements.
- Analog Sensors To add new sensors to the

### Analog Sensors

1. Connect the HOB0 U30 Station to a computer via the USB cable.
2. In HOB0ware, select Stop Logging.
3. Readout the data from the logger.

**IMPORTANT:** All existing data will be lost when you re-launch the logger.

4. Connect the new sensors to the Analog Sensor Port.
5. Configure Analog Sensor Port for the new sensor.
6. Re-launch the logger.

The new sensors should start recording measurements.

## Removing/Replacing a Sensor

---

If you remove a Smart Sensor while the HOB0 U30 Station is logging, the Logging LED will blink red, and the logger will record erroneous data for that channel and continue logging as normal for the remaining Smart Sensors. This behavior will continue even if you plug the Smart Sensor back in, or if you plug in a new one of the same type.

To stop recording erroneous data after removing a Smart Sensor, you will need to stop, readout, and re-launch the HOB0 U30 Station.

If you are replacing a Smart Sensor with a new one of the same type, you will need to re-launch the HOB0 U30 Station once the new Smart Sensor is installed. The HOB0 U30 Station can continue logging until you stop, readout, and re-launch it with the new Smart Sensor.

You can remove analog sensors from the optional Analog Sensor Port or replace them with new analog sensors of the exact same type in the same channel without having to stop the logger. However, in the case that you are changing the type of sensor, you will need to reconfigure the Analog Sensor Port using HOB0ware, which will require you to stop the logger.

## Testing Smart Sensors

---

Use HOB0ware if you need to verify the accuracy of the Smart Sensors, which is recommended on a yearly basis, or if you need to isolate a Smart Sensor that is generating an error.

1. Connect the HOB0 U30 Station to the computer using the USB cable. If it is currently logging, stop logging through HOB0ware.
2. Unplug all Smart Sensors if you are troubleshooting an error. You can leave them plugged in if you are not getting any sensor errors and you are just checking them for accuracy.
3. Plug one Smart Sensor back in. From the Launch dialog in HOB0ware, check the current reading and make sure it is accurate.
4. Repeat with the remaining Smart Sensors.

## Checking the U30 Status

---

To check the U30 Status:

1. From the main menu go to **Device > Status** to open the **Status** window.

The **Status** window appears, showing the status of the logger and the attached sensors.

2. Verify Sensor Readings

Change the sensor readings by changing the conditions.

For example, if you are measuring temperature, hold the temperature sensor in your hands for a minute or two and verify that the temperature shown in the Current Readings increases.

3. Close the **Status** window by clicking OK.

## **Inspecting the HOBO U30 Station**

---

Periodically perform a visual inspection of the HOBO U30 Station. Verify that the enclosure is free of visible damage, such as cracks, and that it is clean.

Check that all cables and wires are:

- Free of damage, such as cracks, cuts, and splits.
- Protected in conduit if necessary (exposed cables are prone to being chewed by rodents and should be protected in conduit in locations where rodents are present).
- Fastened securely.
- Free of corrosion and in good condition. If moisture is visible inside the white enclosure or there is any sign of corrosion on the connectors, spray WD-40® or an equivalent electronics-safe corrosion inhibitor on the connectors. This will displace moisture and prevent additional corrosion.
- Onset recommends that you wipe off any water on the outside of the HOBO U30 case before opening it.



## Troubleshooting the HOB0 U30 Station

---

### No status indicators are blinking

- The indicators are very faint under direct sunlight. If no indicators appear to be blinking, shield the logger from the light and check the indicators again.
- Check the status in HOBOLink. Make sure the battery power is not too low. There needs to be at least 3.5 volts for logging to continue and 3.9 volts for cellular communication.
- The memory may be full. Read out the logger and re-launch.
- The logger may not have been launched.

### I made a change to the Launch or Readout Configurations, but it hasn't taken place

Any changes you make to the Launch or Readout Configurations will not take effect until the next time the HOB0 U30 Station connects to the HOBOLink. If your connection interval was set to 2 hours, then changes won't take effect until the next connection on that 2-hour schedule.

### The power has run out

- Recharge the battery for 12 hours with AC adapter.
- If it cannot be recharged, you will need to replace the battery. Contact your Onset Authorized Dealer or Onset Technical Support.
- **NOTE:** The U30 Station uses very durable, high-capacity Flash memory. With this memory, data is retained even when the battery runs out of charge.
- **Important:** Do not re-launch the logger until the data has been recovered. If, the battery cannot be recharged and, you are still unable to read out the HOB0 U30 Station, contact the vendor that sold it to you. It may be possible to retrieve the logged data.

### Too many calls are being made to HOBOLink

Select a slower connection interval in Readout Configuration. Or, consider turning on "Night Mode," which allows you to set up a second, slower connection interval overnight.

### Too much battery power is being used

Make sure the solar panel is installed properly and functioning. That should provide enough power to recharge the battery during the day. Or, use the AC adapter to recharge the battery.

### Only some of the installed sensors are logging

- Check for a loose connection.
- If using the Smart Sensor Expander board, make sure it is connected to the built-in Smart Sensor board with the expander cable.
- Make sure you have not exceeded 100 meters (328 ft) of network cable for all Smart Sensors.
- Make sure you have not exceeded 15 data channels. Use HOBOWare to see a list of all installed sensors and Analog Sensor Ports in the Launch window. The Smart Sensors are listed in ascending order by serial number. If more than 15 data channels are connected,

the devices with the higher serial numbers will be ignored and their data will not be recorded.

#### Data file contains errors

In rare circumstances, the data file may have become corrupted. Contact your Onset Authorized Dealer or Onset Technical Support.

#### I launched the HOBO U30 Station in HOBOWare, but my settings are not being logged

Launches attempted with HOBOWare will be overridden by the Launch Configuration set up in HOBOLink the next time a connection made. If the HOBO U30 Station is communicating with HOBOLink, then it most likely has been re-launched with the settings saved in HOBOLink.

#### Device is not found when connected to HOBOWare

Check USB cable connections. Check the computer's COM port/USB settings.

#### I set the Launch Configurations, but it is not logging

If it is the first launch, make sure you have entered a Readout Configuration. If it is not the first launch and the HOBO U30 Station is connecting but still not launching, then select "Force Relaunch on Next Connection" and wait for the next connection.

# THE SMART SENSOR EXPANDER BOARD

## Opening the Secondary Cable Slot

Whether the Smart Sensor Expander Board was installed at the factory, or you are installing one yourself, you must remove the piece covering the Secondary Cable Slot to access the board. You should leave the cover installed until you are ready to use the Expander Board.

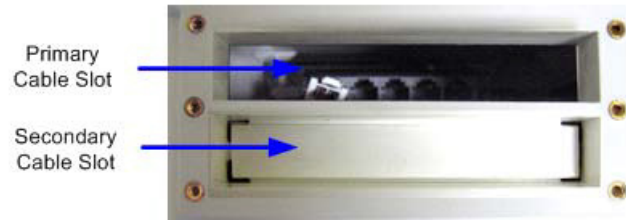

Figure 24: Primary Cable Slot

### Steps

1. Make sure the HOBO U30 Station is turned off and all cables are disconnected.
2. Use a hammer and a bladed tool (e.g., screwdriver, chisel) to punch through at the four corners and at the ends of the piece covering the secondary cable slot.



Figure 25: Opening Secondary Cable Slot

3. Punch through along the bottom of the knockout and then tap sharply in the middle to break into the opening. Remove the hanging flap.

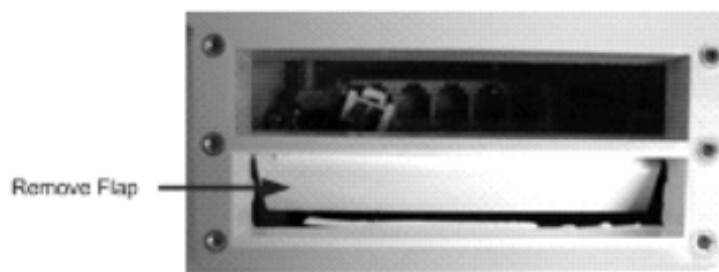

Figure 26: Removing Flap

4. Peel away any residual material.

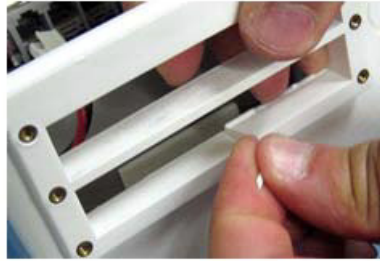

Figure 27: Removing Residual Material

5. File any rough edges. For best results, the surfaces in the cable access opening should be smooth so that the rubber cable channel gasket will seal.

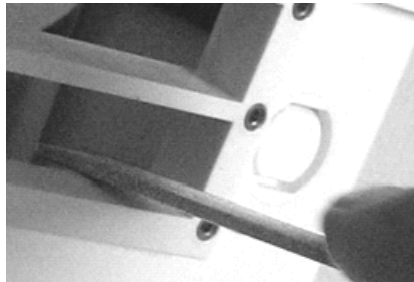

Figure 28: Filing Rough Edges

# Installing the Expander Board

---

## Before You Begin

If you have not already done so, open the Secondary Cable Slot (see page 54).

## Steps

1. Insert a self-tapping screw (supplied) into each end of the expander.
2. Lower expander onto the two standoffs near the bottom of the case.
3. Attach the Expander Board to the logger using the included screws.

**Alternate Method:** Place expander (without the screws) onto the standoffs. Apply a small amount of clear grease (the grease supplied with this kit can be used) at the end of the screwdriver to hold screws while lowering them into place.

**NOTE:** The contacts of the expander jacks should be nearest to the bottom of case as shown below.

**CAUTION:** Be careful not to trap the battery cable behind the board.

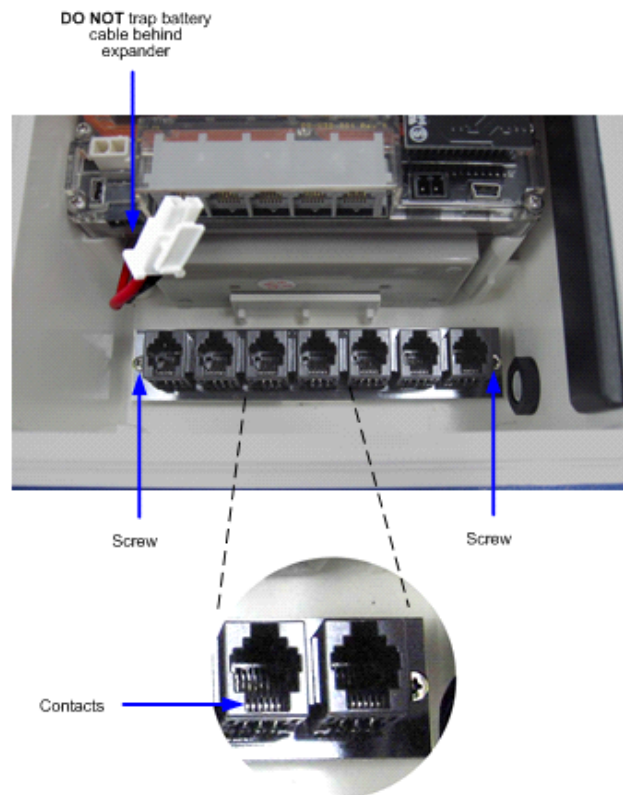

Figure 29: Installing the Expander Board

4. Install Connector Cable

- a. Plug one end of the supplied expander cable into the rightmost jack of the expander board.
- b. Plug the other end into the rightmost jack of the built-in board.

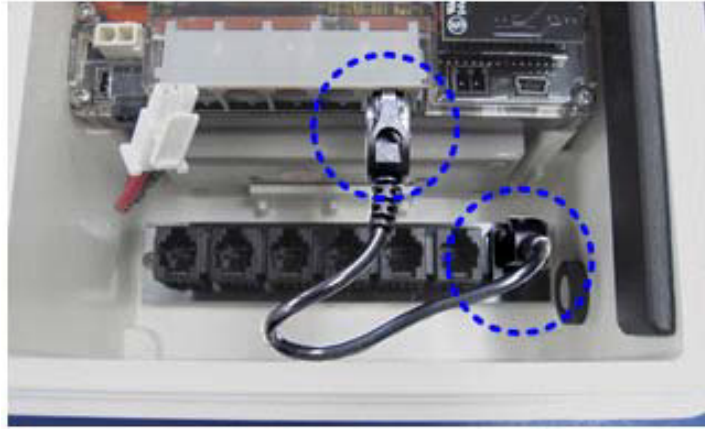

Figure 30: Installing Connector Cable

# THE BATTERY

## Overview

---

The HOBO U30 Station has a 4-volt sealed lead-acid battery that powers the U30 logging system. The cellular radio that provides the wireless connection to HOBOLink is also powered by the battery and must be frequently charged for proper operation.

**IMPORTANT:** The cellular radio module requires a minimum battery voltage of 3.9 VDC for proper operation.

You can view the Battery State on the Latest Conditions panel and the Device Information panel on the HOBOLink Device window.

## Charging the Battery

Much like a mobile phone, the battery will start to run down if it is not recharged. Therefore, the system requires either a solar panel or an AC adapter plugged in to ensure the battery does not run too low.

Even rechargeable batteries eventually fail, and will not be able to be recharged. With regular usage, the battery should last more than two years. See [Maximizing Battery Life](#) on page 60.

**IMPORTANT:** Due to the self-discharge characteristics of this type of battery, it is imperative that you charge the battery for at least 12 hours every six months at minimum, even if you are not actively using the HOBO U30 Station. Otherwise, permanent loss of battery capacity may occur.

See [Maintaining the Battery](#) on page 63.

## Battery Life

---

If the HOBO U30 Station is deployed outdoors battery life will vary with the following factors:

- Sensor excitation current and warm-up time (most important factor)
- The HOBOLink Connection Interval
- Logging interval (and sampling interval, if applicable)
- Number of sensors being used
- Operating environment (e.g., temperature)
- Size of the solar panel
- Quality and quantity of solar light

### Estimating Battery Life

The HOBO U30 Station is designed to be used with a power source to keep the 4-volt sealed lead-acid battery charged. Ideally, the power source is always connected and the battery will be constantly trickle-charged. If external power source has stopped supplying power (e.g. there is power failure or the solar panel is covered), the HOBO U30 Station is capable of running from battery power alone for extended periods of time.

Use the following table as a guideline for estimating how long a HOBO U30 Station will run without any source of external power. For these examples, the HOBO U30 Station has up to ten sensors installed and no excitation on the Analog Sensor Port.

Connection Interval	Logging Interval	Typical Run Time
10 minutes	1 minute	10 days
1 hour	5 minutes	30 days
6+ hours	30 minutes	60 days

Estimating battery life when excitation is used must be calculated based upon actual drain (current, duration and logging frequency). If excitation averages more than 1 mA, and charging in the field is not possible, it is recommended that the 10 AHr (S100) battery option be used with the HOBO U30 Station.

For additional information on estimating battery life and selecting the correct size solar panel see the Support section at [www.onsetcomp.com](http://www.onsetcomp.com).



## Maximizing Battery Life

---

This topic provides tips for maximizing battery life.

### Reduce the HOBOLink Connection Interval

The single most significant factor that drives battery life is the connection interval. Reducing the connection interval will result in an immediate and substantial reduction in power consumption.

### Maximize Cellular Signal Strength (U30-GSM or U30-C3G Only)

If possible, place the HOBOLink U30 Station in a location that gets good cellular signal strength. Weak signal strength will result in more power consumed per call and more frequent attempts at calls (retries). See page 39 for details on checking signal strength with HOBOLinkware.

### Use the Night Mode feature

The Night Mode feature allows you to set up two connection intervals for readouts: a more frequent schedule when needed and a less frequent schedule during a less critical time.

### Reduce warm-up time

If you are using excitation voltage, select the shortest warm-up time needed for the sensor.

### Ensure that your solar panel gets full sunlight

Solar panels are extremely sensitive to partial shading. Obstructing even a single cell of the panel will result in significant loss of charging power.

### Sampling Interval

Use the sampling interval only if you have sensors that support measurement averaging.

### Stay within the normal operating temperature range

While the logger can operate at temperatures of -40 to 60 C (-40 to 140 F) the battery has much better short and long term performance when maintained between -20 and 40 C (-4 and 104 F). The Sealed Lead Acid will self-discharge. The hotter the battery gets, the faster it will self-discharge. At 20 C, the battery loses about 20% of its capacity in 6 months, but at 50C it loses more than 50%. To maximize battery life (no charging) try to locate the logger where the temperatures will not be above 40 C (104F). Very cold temperatures will reduce the self-discharge rate to almost zero, but the effective capacity of the battery will be reduced. Temperatures below -20 C (-4 F) will reduce the effective battery capacity by more than 25%.

## Battery Voltage

---

The normal operating range for the battery is 3.9 to 4.3 volts. If the voltage drops below the normal range, the HOBO U30 Station will change behavior to maximize the remaining voltage until the battery can be recharged. Alternatively, you may occasionally see a voltage level higher than 4.5 volts.

The following explains what occurs at various voltage levels. The voltage used in determining behavior in the chart is based on a 20-minute average. Even though battery voltage is recorded in the data file at each logging interval and sent to HOBOLink at each connection, the HOBO U30 Station is operating independently on its own internal 20-minute average. This ensures that the appropriate action is taking place within the HOBO U30 Station regardless of how frequently it is logging and connecting to HOBOLink.

### 4.3 to 4.5 volts

The battery is fully charged.

### 4.05 volts

Level at which HOBOLink will notify you that the battery is low (if you have enabled a system alarm for low battery).

### 3.9 volts

Level at which the HOBO U30 Station will stop trying to connect to a cellular tower. Logging will continue. Use the AC adapter to recharge the battery (leave it plugged in for several hours). Plug the solar panel back in when you've finished recharging. When the battery power returns to above 3.9 volts (e.g. the sun comes out or the AC adapter has been plugged in), calls to HOBOLink will resume.

### 3.6 volts

Level at which the HOBO U30 Station will perform a safe shutdown. Logging will stop and no calls will be made to HOBOLink. Use the AC adapter to recharge the battery (leave it plugged in for twelve hours). Plug the solar panel back in when you've finished recharging (plug the battery in first if you unplugged it). The system will resume calls, but you will need to relaunch it using HOBOLink (select Force Relaunch on Next Connection in Launch Configuration). You may want to do a full readout before relaunching to be sure you have all the data from the logger.

### Approximately 3.0 volts

The battery is too low to safely be charged with the HOBO U30 Station and may need to be replaced. Connecting the AC adapter at this point will not recharge the battery. To recharge the battery, a separate battery charger will be required.

If the battery cannot be recharged and you are still unable to read out the HOBO U30 Station, contact the vendor that sold it to you. It may be possible to retrieve the logged data.

**Important:** Do not relaunch the logger until the data has been recovered. The logger uses very durable, high-capacity Flash memory. With this memory, data is retained even when the battery runs out of charge. After you replace the battery, attempt to read out the data. If you are still unable to read out the station once the battery has been replaced, contact the vendor that sold it to you. It may be possible to retrieve the logged data.

## Connecting the Battery

---

This topic illustrates how to connect the battery to the U30 Station.

### Before You Begin

**NOTE:** You should not connect the battery until you have performed Initial HOBOLink Setup (page 11).

### Illustration

Connect the built-in battery cable to the battery as shown below.

**WARNING:** Do not plug in battery here. This is for the solar panel or optional AC adapter.

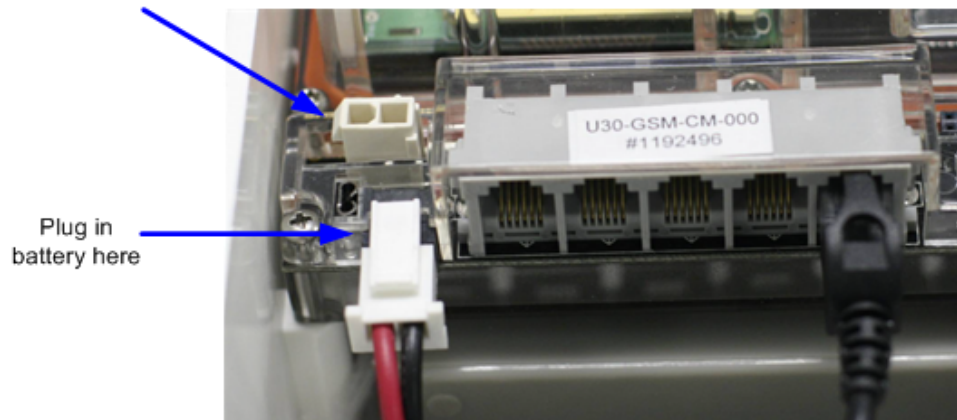

Figure 31: Connecting the Battery

## Maintaining the Battery

---

If you are using a solar panel for recharging the battery and there has been a steady decline in battery voltage, you will need to make a change by either reducing power consumption or increasing recharging current. Start by reducing the logging interval and/or excitation current (if you are using it). Try cleaning the solar panel or repositioning it for maximum sunlight. You can also attempt to recharge the battery for 24 hours.

If the voltage is still low after attempting to recharge the battery with an AC adapter for 24 hours, then you may need to charge it with a current limited variable power supply or replace it.

**IMPORTANT:** Due to the self-discharge characteristics of this type of battery, it is imperative that you charge the battery for at least 12 hours every six months at minimum, even if you are not actively using the HOB0 U30 Station. Otherwise, permanent loss of battery capacity may occur.

### Charging a Dead Battery

In the event the battery is completely dead (less than 3.0 volts and the logger lights do not come on when the battery is connected), you can charge the battery externally with a current limited variable power supply (otherwise you must replace the battery). Hold the battery across a constant voltage source of 4.5 volts with a current limit of 2 Amps. When held at this voltage, the battery will seek its own current level and maintain itself in a fully charged condition. It takes up to 24 hours to fully charge a dead battery.

**IMPORTANT:** Do not apply more than 4.6 volts absolute maximum to the battery. Do not exceed 2 Amps of current when charging. If the battery gets hot, immediately stop charging the battery. If the battery will not hold charge, it must be replaced. Dispose of the old battery per local regulations.

## Replacing the Battery

---

If the battery is completely dead and recharging is not an option, follow these steps to replace the battery:

1. Disconnect the AC adapter or solar panel.
2. Disconnect the battery.
3. Unplug all sensors, the USB cable, relay, and grounding wire.
4. Unscrew the antenna cable with a 5/16 inch wrench.
5. Use a Phillips-head screwdriver to remove the four screws at the corners of the clear, inner case.
6. Remove the clear, inner case.
7. Use a Phillips-head screwdriver to remove the two screws that secure the battery.
8. Note the orientation of the battery and then remove it.
9. Install the new battery with the same orientation and reverse the steps to reassemble.
10. Dispose of the old battery per local regulations.

## Troubleshooting the Battery

---

**Problem:** Too much battery power is being used

- Make sure the solar panel is installed properly and functioning. That should provide enough power to recharge the battery during the day.
- Use the AC adapter to recharge the battery.

**Problem:** The power has run out

- Recharge the battery for 12 hours with AC adapter.
- If the battery cannot be recharged, you will need to replace the battery. Contact your Onset Authorized Dealer or Onset Technical Support.

**Important:** The logger uses very durable, high-capacity Flash memory. With this memory, data is retained even when the battery runs out of charge. Do not relaunch the logger until the data has been recovered. If the battery cannot be recharged and you are still unable to read out the HOBO U30 Station, contact the vendor that sold it to you. It may be possible to retrieve the logged data.

## Battery Life without External Power

---

The HOBO U30 Station is designed to be used with a power source to keep the 4-volt sealed lead-acid battery charged. Ideally, the power source is always connected and the battery will be constantly trickle-charged.

If external power source has stopped supplying power (e.g. there is power failure or the solar panel is covered), the HOBO U30 Station is capable of running from battery power alone for extended periods of time.

The following table can be used as a guideline for estimating how long a HOBO U30 Station will run without any source of external power. For these examples, the HOBO U30 Station has up to ten sensors installed and no excitation on the Analog Sensor Port. It is not recommended that the U30 be deployed for longer than 6 months without any charging as the battery may be damaged from sulfation due to the long-term low-voltage state.

<b>Logging Interval</b>	<b>Typical Run Time</b>
1 second	2 - 3 months
1 minute	6 months
5 minutes	6+ months

Estimating battery life when excitation is used must be calculated based upon actual drain (current, duration and logging frequency). If excitation averages more than 1 mA, and charging in the field is not possible, it is recommended that the 10 AHr (S100) battery option be used with the U30.

See the Support section at [www.onsetcomp.com](http://www.onsetcomp.com) for additional information on estimating battery life and selecting the correct size solar panel.

# REFERENCE

## General U30 Specifications

Normal Operating Range	-20 to 40°C (-4 to 104°F) <b>NOTE:</b> The radio module will not communicate below -30°C (-22°F) and/or battery voltage less than 3.9 VDC. <b>NOTE:</b> Operation within the extended operating range (but outside the normal range) will reduce battery service life.
Sensor Inputs	5 standard; option to expand to 10
Smart Sensor Compatibility	Compatible with most Onset smart sensors. See the following web site for the full list of compatible sensors. <a href="http://www.onsetcomp.com/smart_sensor_accessory_compatibility_chart">http://www.onsetcomp.com/smart_sensor_accessory_compatibility_chart</a>
Data Channels	Maximum of 15 (some sensors use more than one data channel; see sensor manual for details)
Expansion Slot	One expansion slot is available for factory-installed expansion port. Check <a href="http://www.onsetcomp.com">www.onsetcomp.com</a> for the latest list of options
Local Communication	Full Speed USB via USB mini-B connector
Dimensions	18.9 H x 11.8 D x 18.1 W cm (7.4 H x 4.7 D x 7.1 W inches) (see diagrams on next page)
Weight	2.2 kg (4 lbs 13 oz)
Materials	<ul style="list-style-type: none"> <li>• Outer Enclosure: Polycarbonate/PBT blend with stainless steel hinge pins and brass inserts</li> <li>• Inner Enclosure: Polycarbonate with brass inserts</li> <li>• U-Bolts: Steel with zinc dichromate finish</li> <li>• Gaskets: Silicone rubber</li> <li>• Cable entry channel: EPDM rubber</li> <li>• Cable entry bars: Aluminum with ABS plastic thumb screws</li> </ul>
Data Storage Memory	Nonvolatile flash data storage, 512K bytes local storage
Memory Modes	Stop when full, wrap around when full
Operational Indicators	Up to seven (depending upon options) status lights provide basic diagnostics
Logging Interval	1 second to 18 hours, user-specified interval
Battery Type	4 Volt, 10 Ahr, Rechargeable sealed lead-acid

Onset Computer Corp

Rechargeable Battery Service Life	Typical 3-5 years depending upon conditions of use. Operation within the extended operating range (but outside the normal range) will reduce battery service life.
Time Accuracy	0 to 2 seconds for the first data point and $\pm 5$ seconds per week at 25°C (77°F)
Environmental Rating	Weatherproof enclosure, tested to NEMA 6. (Requires proper installation of cable channel system).
Mounting	3.8 cm (1.5 inch) mast or wall mount
Enclosure Access	Hinged door secured by two latches with eyelets for securing with user-supplied padlocks
Alarm Notification Latency	Logging interval plus 2-4 minutes (typical). Onset is not responsible for failed connections or undelivered mail/text messages.
Alarm Output Relay	One relay contact closure can be configured as normally open, normally closed, or pulsed. Voltage: 30 V Current: 1 amp max.
Sensor Network Cable Length	100 m (328 ft) maximum
External Power	<p>External power is required.</p> <p>Solar</p> <p>The U30 accepts the following Onset solar panels: SOLAR-1.2W, SOLAR-3W, SOLAR-6W</p> <p>AC Power</p> <p>AC power adapter: AC-U30</p>
	The CE Marking identifies this product as complying with all relevant directives in the European Union (EU).

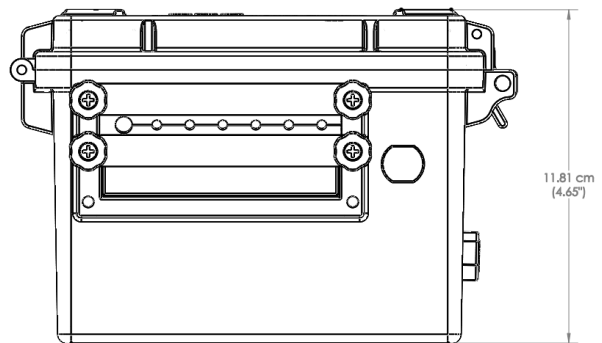
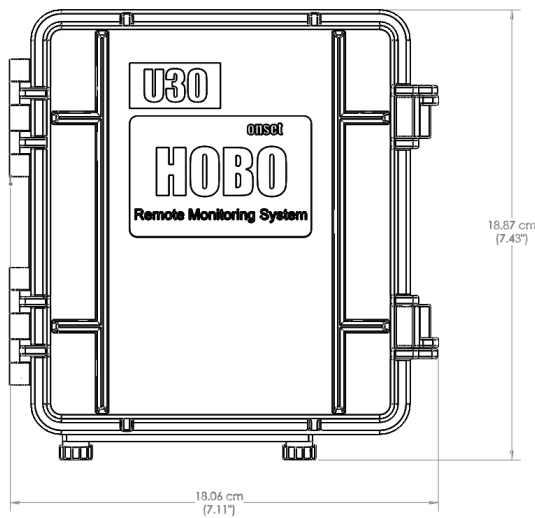



## Cellular/Wi-Fi Specifications

---

### U30-GSM

Wireless Radio	Quad-Band GSM 850/900/1800/1900 MHz
Antenna	Internal Quad-Band
Antenna Connector	Reverse Polarity SMA
FCC Specification	Approved for use in the USA and Canada Contains FCC ID QIPTC65 / IC ID 7830A-TC65 Or FCC ID QIPTC65I / IC ID 7830A-TC65I (See device label for actual IDs)

### U30-C3G

Wireless Radio	GSM/GPRS/EDGE: Quad band 850/900/1800/1900MHz, UMTS/HSPA+: Five band 800/850/900/1900/2100MHz
Antenna	Internal Quad-Band
Antenna Connector	Reverse Polarity SMA
FCC Specification	Approved for use in the USA and Canada Contains FCC ID QIPEHS6, IC ID 7830A-EHS6

### Wi-Fi

Network Standards	IEEE 802.11b ; IEEE 802.11g
Frequency Range	2.412 – 2.484 GHz
Antenna Connector	1, no diversity supported.
Data Rates	1,2,5.5,11Mbps(802.11b) 6,9,12,18,24,36,48,54Mbps(802.11g)
Radio: Number of Selectable Subchannels	Up to 14 channels. Profiles available will include USA, France, Japan, Spain, Canada and "Other" (multiple countries)
Radio: Modulations	OFDM, DSSS, DBPSK, DQPSK, CCK , 16QAM, 64QAM

Radio: Antenna Connector	1
Security	WEP 64/128, WPA – PSK, TKIP, AES end-to-end encryption
Maximum Receive Level	-10 dBm (with PER < 8%)
Receiver Sensitivity	-72dBm for 54Mbps -87 dBm for 11Mbps -89 dBm for 5.5Mbps -90 dBm for 2.0Mbps -92 dBm for 1.0Mbps
Antenna Type	Internal Antenna with Reverse SMA connector

## Analog Sensor Port

---

### Specifications

Input Channels	Two, single-ended
Field Wiring	Two- or three-wire via screw terminals on detachable connector, 16–24 AWG
Replacement detachable connectors	Part of spares kit, Part No. A-FS-CVIA-7P-1
Input Range	User-configurable: 0–20 mA DC, 0–2.5 VDC, 0–5 VDC, 0–10 VDC, and 0–20 VDC (the voltage range is determined based on the raw values entered for the voltage scaling in HOBOWare)
Minimum/Maximum Input Voltage	0 / 24 VDC
Minimum/Maximum Input Current	0 / 24 mA DC
Minimum Current Source Impedance	> 20 K $\Omega$
Accuracy	$\pm$ 0.25% of FSR from 50mV to FSV
ADC Resolution	12 bits

## Analog Sensor Port Functional Diagram

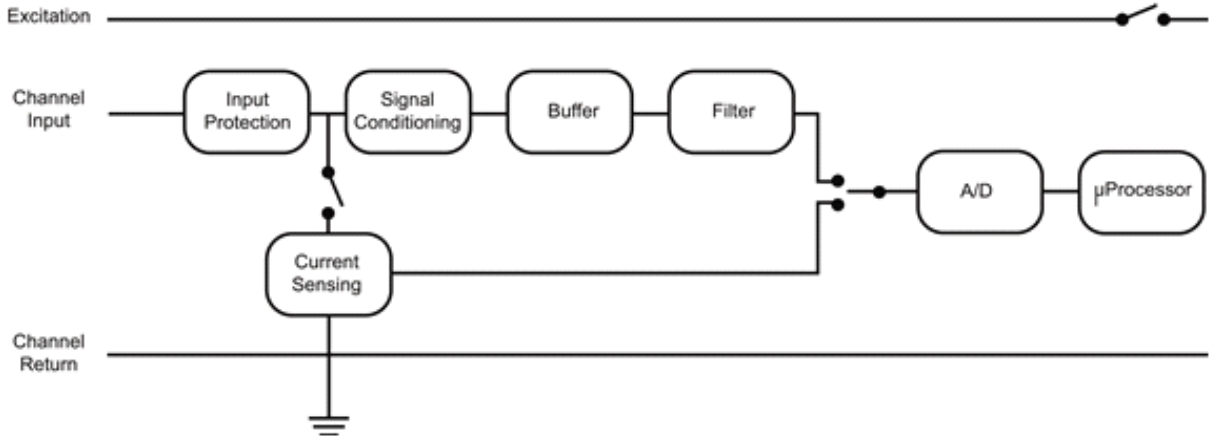

## Pinout

Pin# Left	Function	Pin# Right	Function
1	Shield	1	Shield
2	Channel 1 Signal	2	Channel 2 Signal
3	Channel 1 Return	3	Channel 2 Return
4	Excitation Voltage	4	Excitation Return

## Time Accuracy

The internal clock in the HOBO U30 Station is set by the time on the HOBOLink server and the time zone offset from UTC that you select when you configure the device. UTC, or Coordinated Universal Time, is similar to Greenwich Mean Time.

The time zone offset makes it possible to determine objective, non-local time. This prevents conflicts and confusion before a Spring or Fall time change.

Once the logger is logging, it will keep fairly accurate time. However, the following may cause errors with time reporting:

- Launch time loss

The HOBO U30 Station may lose up to two seconds when it is launched. This is unavoidable.

- Clock drift

The long-term time accuracy is related to ambient temperature. At 25°C (77°F), the worst-case error is  $\pm 8$  parts per million (PPM), or about 5 seconds per week. The error increases as the temperature deviates from 25°C, as shown in the graph below. At a constant temperature of 20°C, the logger time error could be as much as 35 PPM (21 seconds per week).

The following graph shows the worst-case time error.

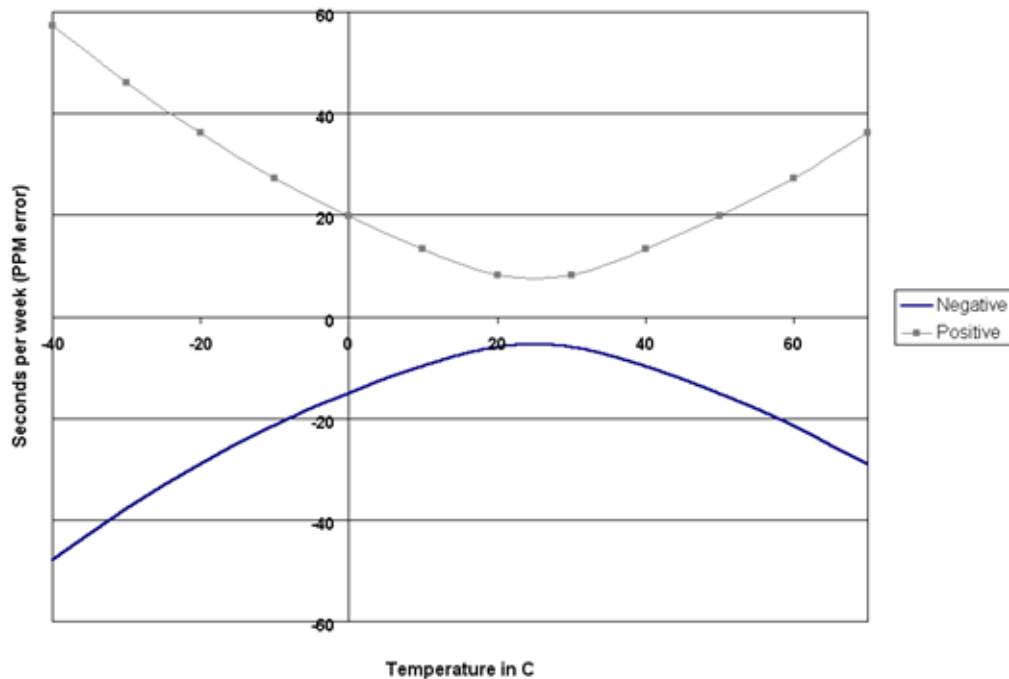

Figure 32: Time Accuracy Graph

## Memory

---

The HOBO U30 Station contains 512K bytes of very durable, high-capacity, non-volatile Flash memory, which stores data even if power runs out. Although the HOBO U30 Station has a rechargeable battery, the data would still be retained even if it were to run out of power.

If you have enabled the Wrap Around When Full feature in the Launch Configuration, then memory limitations are not a concern. Once the HOBO U30 Station is full, the oldest data will be overwritten with the newest data and logging will continue indefinitely.

If you have the Wrap Around When Full feature turned off, the rate at which the memory will fill up depends on the number and type of sensors connected and the logging interval. This is called the logging duration. Adding sensors decreases the logging duration; increasing the logging interval increases the logging duration.

The following table shows the expected run time for several logging intervals based on the total number of bits in place, which is determined by adding together the bits per sample for each sensor measurement parameter in your system. For example, a HOBO U30 Station with the following sensors is using 49 total bits.

Sensor		Bits per Sample		Total bits
1 temperature sensor	X	12	=	12
1 wind speed sensor	X	16	=	16
2 temperature sensors	X	12	=	21
<b>Total number of bits</b>				<b>49</b>

At a logging interval of 5 minutes, the logging duration for a logger using 56 bits would be approximately 250 days. (Refer to the sensor manual to determine the number of bits each type of sensor uses.)

## Connection Status LEDs

---

This topic describes the Connection Status LEDs on the U30 Station Remote Communication models.

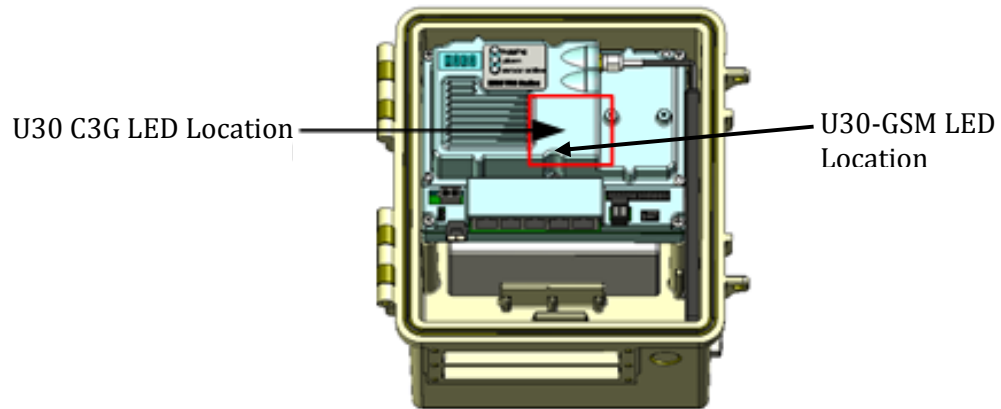

Figure 33: Connection Status LEDs

### Server/USB Communication (Green)

- Blinking

There is active communication from the HOB0 U30 Station to HOB0link or there is a connection to a computer through the USB port.

### Network Connection

#### U30-GSM (blue)

- Double-blink with a brief pause followed by double-blink: Attempting to find a cellular tower.
- Single blink with long pause followed by a single blink: A cellular tower has been found.
- Double-blink with long pause followed by a double blink: A connection was made to HOB0link.

#### U30-C3G (green)

- Quick 1-second blink: Call in progress or established.
- Quick 2-second blink: Data is being transferred.
- Slower 3-second blink: Device is registered to a network, but no call or data transfer is in progress.
- Flashing (every half-second): Logger communicating with the cell phone module.

Persistent flashing could mean invalid network credentials, a missing SIM card, an expired account, or limited “out of range” network service.

Note that most data transfers should take no longer than 1 minute.

U30-WIFI

On - The LED will be on whenever the Wi-Fi radio is on.

U30-ETH

On - The LED will be on whenever there is Ethernet activity.

Analog Sensor Port Status

- Blinking Green

The Analog Sensor Port is logging.

- Blinking Orange

Excitation has been turned on for the Analog Sensor Port.

## Logger Status LEDs

This topic describes the Logger Status LEDs, located on the interior enclosure of the U30 Station.

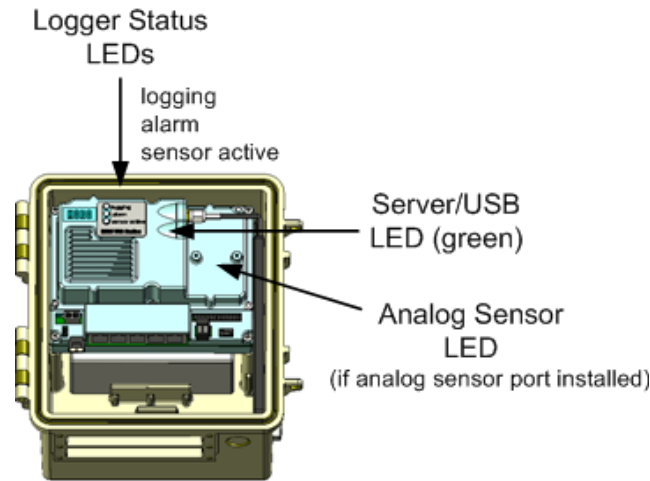

Figure 34: Logger Status LEDs

**NOTE:** The LEDs are very faint under direct sunlight. If no indicators appear to be blinking, shield the logger from the light.

### Logging

- Blinking green

Indicates the system is currently logging. It blinks every two seconds while the logger is recording data from sensors. Do not add sensors while this indicator is blinking. If this indicator is not blinking when you believe it should, make sure the HOB0 U30 Station has been launched.

- Blinking red

There was a Smart Sensor or Analog Sensor Port communication failure. Investigate this problem immediately. Look for a loose connection, which could cause bad electrical contact with a sensor. If found, remove the offending sensor and check its wires and connector for damage and/or signs of moisture.

- Blinking orange

There was a communication failure, but the system has recovered. There may be an intermittent problem. Try checking the Smart Sensors one at a time to make sure they are all communicating. If you find a bad sensor, or if no sensor communicates, contact your Onset Authorized Dealer or Onset Technical Support.

### Alarm

- Blinking: An alarm was tripped.

### Sensor Active

- Blinking: Indicates Smart Sensor network communications are occurring.



## **Items Required for Field Installation**

---

### Equipment

- Solar panel or AC power adapter
- Rubber cable channel(s)
- Cable channel retaining bars
- Optional relay output wire (user-supplied), 4.0 mm (0.157 in.) diameter
- Mounting kit and U-bolts
- Grounding wire

### Tools

- Phillips-head screw driver
- Small flat-head screw driver for Analog Sensor Port screw terminals (if applicable)
- Wrench or socket driver
- Silicone grease
- Plugs for unused cable channel holes
- Phillips-head screw driver
- Wrench or socket driver

## Accessories

---

The following accessories can be used with the HOB0 U30 Station. These accessories can be purchased from an Onset Authorized Dealer, or directly from Onset Computer Corporation. For detailed information on these accessories, including new items that may have been introduced after this manual was printed, refer to [www.onsetcomp.com](http://www.onsetcomp.com).

1.2 Watt, 6 Volt Solar Panel (SOLAR-1.2W)	Solar Panel for sunny locations and/or locations with low data transfer requirements.
3.0 Watt, 6 Volt Solar Panel (SOLAR-3W)	Solar Panel for moderately cloudy locations, higher latitudes, and/or medium data transfer requirements.
6.0 Watt, 6 Volt Solar Panel (SOLAR-6W)	Solar Panel for very cloudy locations, higher latitudes, and/or high data transfer requirements.
AC Adapter (AC-U30)	120 V AC, 60 Hz AC linear power supply. Output 6 Volts DC, 2 Amp.
AC Adapter (Europe) (AC-U30-EU)	240 V AC, 50 Hz AC linear power supply. Output 6 Volts DC, 2 Amp.
5-Input Smart Sensor Expansion Kit (S-ADAPT-X5-10)	Kit that increases the number of Smart Sensor inputs from 5 to 10.

## **FCC Part 15 Compliance**

---

### Disclaimer and Revisions

This equipment has been tested and found to comply with the limits for a Class B digital device, pursuant to Part 15 of the FCC Rules. These limits are designed to provide reasonable protection against harmful interference in a residential installation. This equipment generates, uses, and can radiate radio frequency energy and, if not installed and used in accordance with the instructions, may cause harmful interference to radio communications. However, there is no guarantee that interference will not occur in a particular installation.

If this equipment does cause harmful interference to radio or television reception, which can be determined by turning the equipment off and on, the user is encouraged to try to correct the interference by one of the following measures:

- Reorient or relocate the receiving antenna.
- Increase the separation between the equipment and receiver.
- Connect the equipment into an outlet on a circuit different from that to which the receiver is connected.
- Consult the dealer or an experienced radio/TV technician for help.

This device complies with Part 15 of the FCC Rules. Operation is subject to the following two conditions: (1) This device may not cause harmful interference, and (2) this device must accept any interference received, including interference that may cause undesired operation.

## Wi-Fi Compliance

---

The HOB0 U30-WIFI meets the following agency approvals:

UL 60950:2003

CAN/CSA-C22.2 No. 60950:2003

EN 60950:2003 +A1-A4, A11, Low Voltage Directive (73/23/EEC)

EMC & Radio: For purposes of certification, the WiPort was installed in a standard box (the Lantronix WiBox™).

CFR Title 47 FCC Part 15, Subpart 15, Class B

FCC Module Approval

FCC Identifier: R68WIPORT

Industry Canada ICES-003 Issue 4 (2004), Class B

Industry Canada Module Approval IC: 2867A-WIPORT

EN 301 489-1 v1.4.1 (2002-08), EMC Directive (89/336/EEC)

EN 301 489-17 v.1.2.1 (2002-08), EMC Directive (89/336/EEC)

EN 300 328 v1.4.1 (2003-04), R&TTE Directive (1999/5/EC)

Australia / New Zealand AS/NZS CISPR 22 (2002), Class B

Australia / New Zealand AS/NZS 4771 (2000 + A1:2003)

Japan VCCI (EMC emissions)

Japanese Module Approval

004NYCA0143

004GZCA0077

CISPR 22 (2003)

CISPR 24 (A2:2002)

# Ethernet Compliance

---

## *EC DECLARATION OF CONFORMITY*

### **We:**

Onset Computer Corporation  
470 MacArthur Blvd.  
Bourne, MA 02532  
Phone: (508) 759-9500  
Fax: (508) 759-9100

Declare under our sole responsibility that the product,

U30-ETH

Serial number 2405020 or greater,

to which this declaration relates is in conformity with the following standards or other normative documents:

### **EMC Emissions:**

EN 55022:1998/A1:2000/A2:2003 Class B ITE

EN 61000-3-2: 2005 Class A

EN 61000-3-3: 2001

### **EMC Immunity:**

EN 55024:1998/A1:2001/A2:2003 ITE including:

EN 61000-4-2: 2001 (ESD)

EN 61000-4-3: 2006 (RFI)

EN 61000-4-4: 2004 (EFT)

EN 61000-4-5: 2005 (Surge)

EN 61000-4-6: 2006 (CRFI)

EN 61000-4-11: 2004 (Voltage Dips and Interrupts)

**Responsible Person:** Glenn Greenough

**Date:** July 7, 2009

**Place of issue:** Bourne, Massachusetts, USA

D-12738-B

# TRIPOD SETUP

---

## Guidelines for Typical Field Setup

---

### Site Selection

Use the following guidelines to help you choose an appropriate site for setting up the Station and protecting against field hazards.

- When possible, select a location away from trees and buildings, particularly if you will be using the rain gauge or wind speed sensors. Place the rain bucket at a distance away from obstructions that is equal to at least three times the height of the nearest tree, building, or other obstruction, and the wind speed sensor at a distance away from obstructions that is equal to at least five times the height of the obstruction.

**⚠ WARNING: Severe shock hazard.** Do not set up the HOBO Station near power lines. Contact between the HOBO Station and power lines may result in a fatal shock, electrocution, or death.

- Avoid placing the logger in extremely hot locations (such as on a dashboard or the roof of a greenhouse) and chronically wet locations (such as in a well or any place that is wet most or all of the time). Also avoid rising water and flood zones.
- Conduit is recommended when placing a sensor in or near the ground to protect against animals, lawn mowers, tractors, exposure to chemicals, etc.
- Beware of rodents, birds, cattle, and other animals that can bite, peck, or trample the HOBO Station.
- Avoid placing the sensors near falling rocks, dead trees, or other objects that could fall on the HOBO Station.
- A Grounding Kit (Part # M-GKA) is required if using the Wind Speed or Wind Direction sensor with the logger. A Grounding Kit is recommended if the logger will be placed in an exposed location on a tripod or tower to reduce the chance of damage from atmospheric electrical activity.
- If possible, avoid sites immediately adjacent to radio/television/microwave towers and equipment. In rare situations, strong electromagnetic interference may result in sensor network errors.
- Take note of the mounting considerations in the sensor manuals for additional guidelines relative to the particular sensors you are using.
- For areas with winds greater than 50 mph, or if the rain gauge is attached to the top of the mast, use the Guy Wire Kit (Part # M-GWA) and 1/2 inch Stake Kit (Part # M-SKA) to reduce wind-induced vibration.
- **2 meter Tripod Tower Assembly (Part # M-TPB):** You must set up the tower on level ground; there should be no ground slope. The legs on the 2 meter tower are non-adjustable. If the site you are using is not level, then you will need to either level it or use shims to level the tripod. Be prepared to dig if necessary. Suggested Mounting: Use 1/4 inch Stake Kit (Part #M-SKB).
- **3 meter Tripod Tower Assembly (Part # M-TPA):** The maximum ground slope is 13 degrees. The legs on the 3 meter tower allow for limited adjustment on uneven ground. Be prepared to dig if necessary if the slope is significant. Suggested Mounting: Use 1/2 inch Stake Kit (Part # M-SKA).

- Onset recommends that two people set up most tripod systems. Some assemblies are heavy and are easier to handle with two people.
- Be sure to stabilize, level, and secure the tripod on firm ground. It may be necessary to adapt the installation to the existing site conditions as necessary (for example, if mounting the tripod on ice or rock, you may need to use a masonry clamp to secure it).
- If operating in a wet environment, place several desiccant packs in the logger and plug the vent hole in the bottom of the logger enclosure to minimize moisture.

## Mounting

It is possible to mount the logger and sensors on either a 1.5 meter or 3 meter mast (Part # M-MPB and M-MPA respectively). The shorter mast is especially useful for smaller system configurations where you are trying to minimize the size and visibility of the system.

There are many ways to install the mast depending on the site. Common mounting methods include pounding the post into the ground, setting it into concrete, and bolting it to existing structures.

- If you will be mounting PAR, wind speed, or rain gauge sensors, be sure that you install the mast vertically (using Mast Level, Part # M-MLA).
- Use the Guy Wire Kit (Onset Part # M-GWA) to stabilize a tall mast. Use 1/2 inch stakes (Part # M-SKA) to secure the guy wires.
- Mount the logger vertically and high enough that ground splash will not enter the vent on the underside of the enclosure.
- If using U-bolts, make sure they are for 1-5/8 inch pipe because that is the hole spacing on the logger mounting bracket.
- If mounting the logger to a post or wall, note that it is 2.06 inches between the center of the holes in the mounting brackets. It is recommended that you use 5/16 inch diameter bolts to mount the logger.

## Installing Sensors

- If running cables along the ground, we recommend running them through conduit to protect them from animals (some animals like to chew on the cables), lawn mowers, and being tripped on.
- For information on protecting the sensors properly, refer to the sensor manuals.
- Leave enough slack in the cables so that they can be routed into the logger.
- If you are deploying multiples of the same sensor type, be sure to note the serial number on the cable associated with each measurement location so you can interpret the data later.

## Field Preparation Checklist

---

Use the following checklist to make sure you have all the necessary materials for setting up a HOBO Station.

✓	<b>Task</b>
	Check that you received all the parts for the HOBO Station system as ordered.
	Configure the logger. Install batteries and set up the logger for launch.
	If you opened any parts: Double-check the packing lists to make sure no pieces are missing.
	Attach the mounting feet to the logger. See the logger's manual.
	If you are using the Solar Radiation Shield: Set up the Temperature and Temperature/RH sensors. There are several small pieces required to connect these sensors to the shield that could easily get lost in the field. It is strongly recommended you install these sensors in the solar radiation shield before going to the field. See the sensor manual for details.
	If you are using the barometric pressure sensor, attach it to the logger now. See the sensor manual for details.
	Repack the logger and sensors for transit. It is strongly recommended that you use the original packaging when possible because it is custom-designed to protect the weather station and its components.



## Items Required for Installation

---

Use the following checklists to make sure you have the necessary tools to set up the logger in the field. "Optional" Items depend on your site needs.

### 3 m Tripod (M-TPA) or 2 m Tripod (M-TPB) with Mast

- 1/2 inch wrench
- Mast level (Part # M-MLA)
- Medium size wire cutters
- Crescent wrench
- All-purpose grease
- Tape measure
- Tie wraps
- Redimix cement (optional)
- Shovel (optional)

### 3 m Mast (M-MPA)

- 1/2 inch wrench
- Sledgehammer or post driver
- Eye protection—safety glasses (if using sledgehammer/post driver)
- Mast level (Part # M-MLA)
- All purpose grease
- Tape measure
- Redimix cement (optional)
- Shovel (optional)

### Cross Arm (M-CAA) or (M-CAB)

- 1/2 inch wrench
- Crescent wrench

### Grounding Kit (M-GKA)

- 1/2 inch wrench
- Sledgehammer
- Eye protection—safety glasses
- Medium size wire cutters

### Solar Radiation Shield (M-RSA)

- \_\_\_ 1/2 inch wrench
- \_\_\_ Phillips head screwdriver #1 (if sensors are not already installed)

### Light Sensor Bracket (M-LBA)

- \_\_\_ 1/2 inch wrench

### Guy Wire Kit (M-GWA)

- \_\_\_ Phillips head screw driver #2
- \_\_\_ 1/2 inch wrench
- \_\_\_ Medium size wire cutters
- \_\_\_ Crescent wrench

### Stake Kit (M-SKA) or (M-SKB)

- \_\_\_ Sledgehammer
- \_\_\_ Eye protection—safety glasses

### 1.5 m Mast (M-MPB)

- \_\_\_ Sledgehammer or post driver
- \_\_\_ Eye protection—safety glasses

### Mast level (Part # M-MLA)

- \_\_\_ All-purpose grease
- \_\_\_ Tape measure
- \_\_\_ Redimix cement (optional)
- \_\_\_ Shovel (optional)

## Task 1: Assemble Tripod

There are two types of tripods available: the 2 meter (Part # M-TPB) and 3 meter (Part # M-TPA). The 2 meter instructions begin on this page. The 3 meter instructions begin on page 89.

### 2 meter tripod/lower mast assembly instructions

This is an example of a typical 2 meter tripod assembly with a Rain Gauge sensor mounted on separate 1.5 meter mast (the Rain Gauge should be further from the tripod in the field than shown in this example).

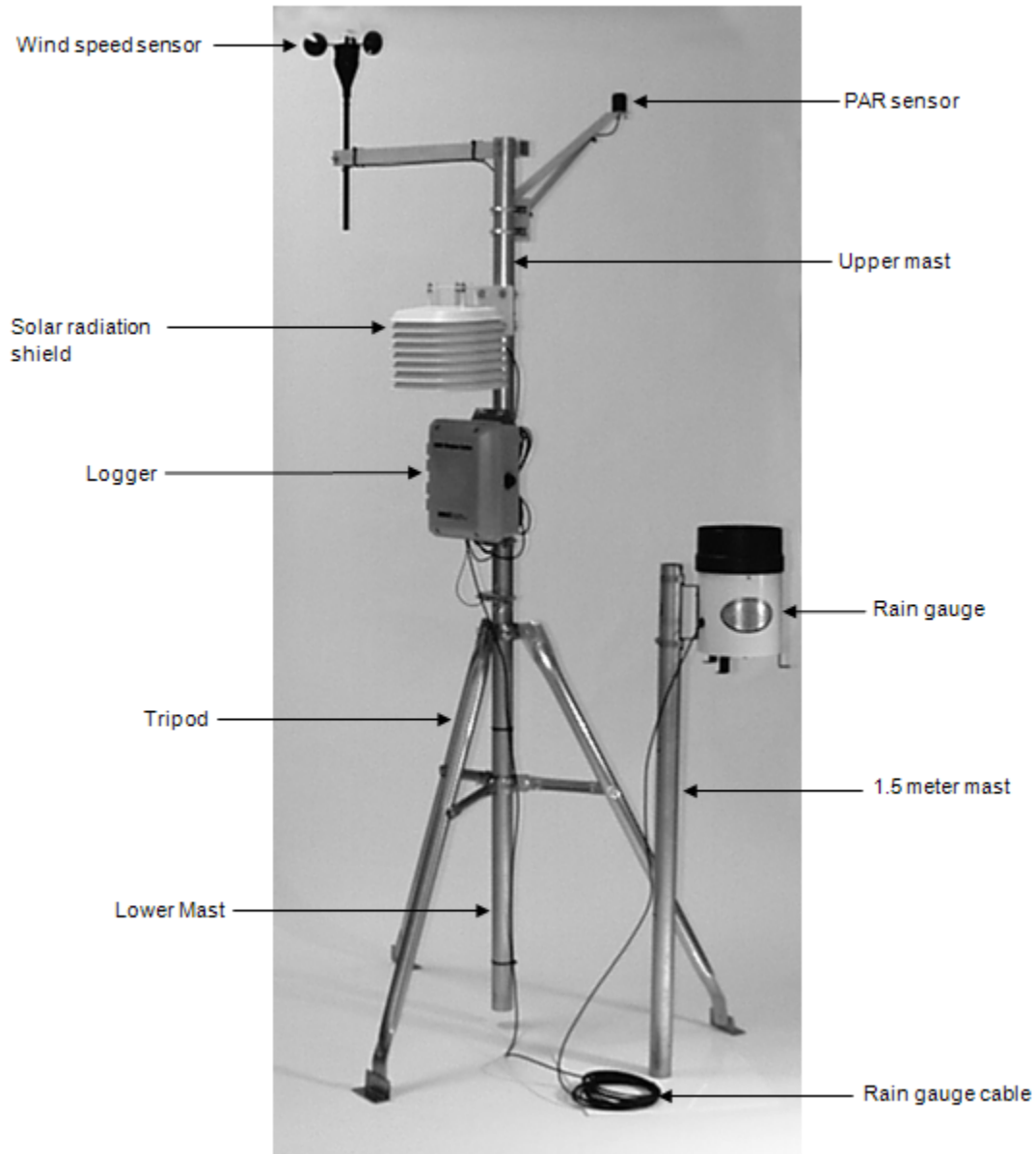

Figure 35: 2 Meter Tri-pod

1. Open the 2 meter tripod and place it in an upright position.

- Using a 1/2 inch wrench, build six nut and bolt assemblies (5/16-18) like the one shown below.

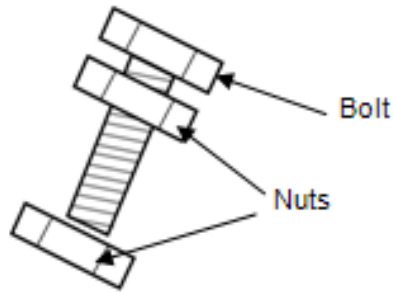

Figure 36: Nut and bolt assembly

- Take one of the nut and bolt assemblies and insert it through a tri-clamp hole with the bolt head facing outward.
- Loosely install a nut on the bolt to the inside of the tri-clamp.

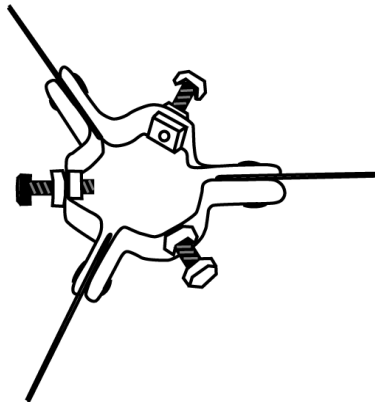

Figure 37: Tri-clamp and bolts

- Install the remaining five nut and bolt assemblies in the same manner for both upper and lower tri-clamps. Make sure the bolt assemblies on the upper and lower mast tri-clamps leave enough room for the lower mast section to slip through.
- Slide the lower mast from the top into the tri-clamps with the creased end of the mast facing up. The creases on the lower mast should face north and south.

7. Tighten the tri-clamp bolts by hand so that the mast is temporarily locked into position.  
**Note:** The lower mast can rest on the ground at this time. You will adjust the height of the lower mast later.

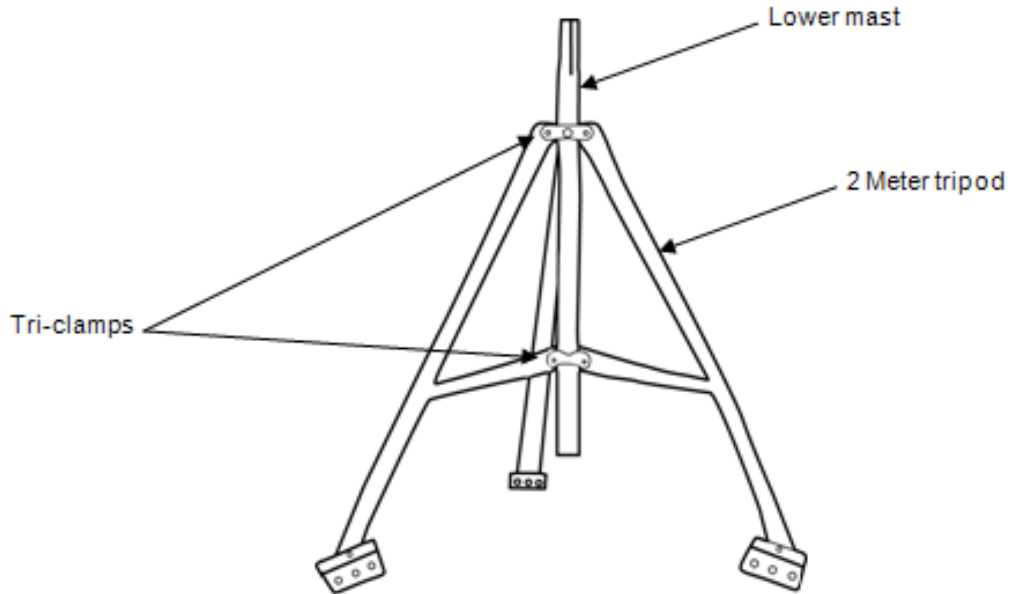

Figure 38: 2 meter tripod - lower mast

8. Because the tripod for the 2 meter configuration has non-adjustable legs, you must verify that the mounting surface area is level. If it is not, use shims or remove soil as needed. You can attach the Post Level (Part # M-LVA) to the mast to verify that it is vertical as you level the surface. You can also use the tri-clamp bolts to fine tune the vertical adjustment later after you adjust the height of the mast.
9. Secure the tripod. Use either the ¼-inch diameter stake kit (Part # M-SKB) or bolt the tripod to cement pads with ¼-inch anchors. Install a stake or bolt through one of the holes on each of three tripod feet.
10. If site conditions (high winds, etc.) warrant further stabilization of the tripod, use the Guy Wire Kit (Part # M-GWA). See Task 7: Install Guy Wire Kit on page 98.

### 3 meter tripod/lower mast assembly instructions

This is an example of a typical 3 meter tripod assembly with a mast-mounted Rain Gauge sensor.

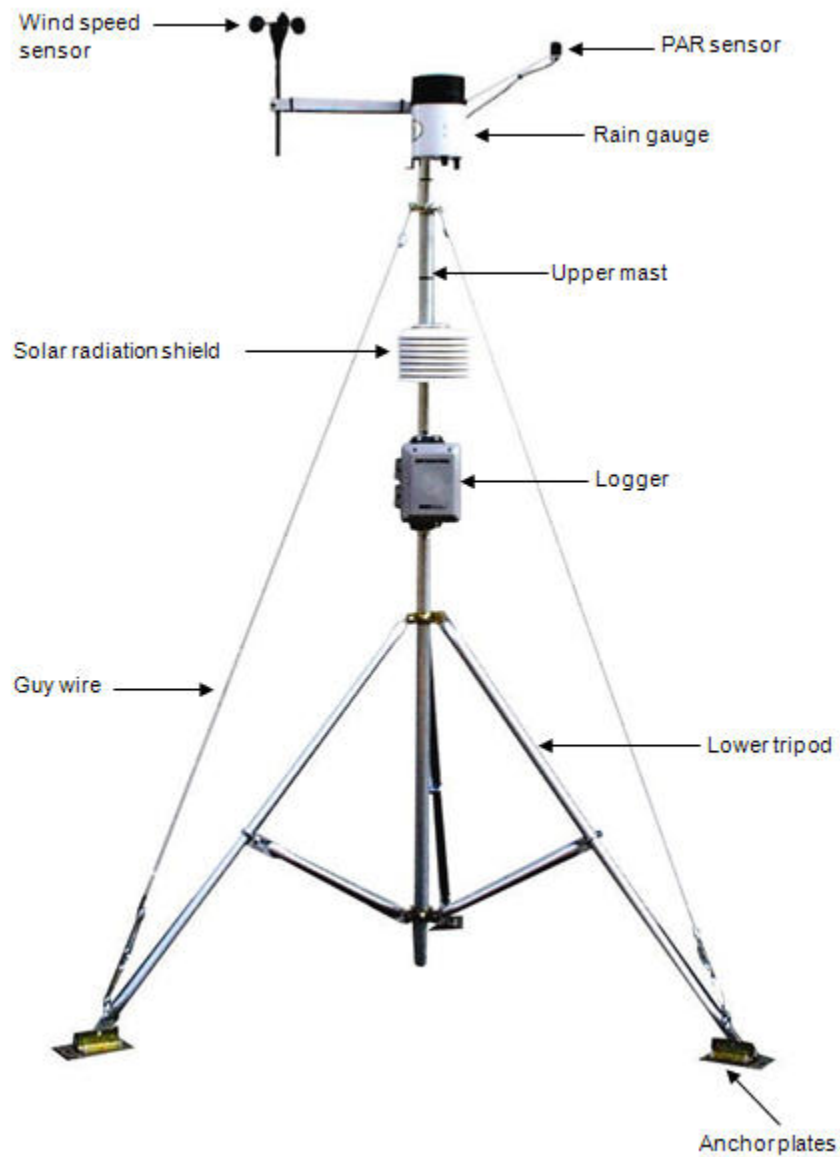

Figure 39: 3 meter tri-pod

1. Using 5/16 inch nuts, attach the three anchor plates to the three tripod foot brackets, with the large holes to the outside. Tighten the nuts securely.

2. Attach the three leg U-bolts with saddle clamps, one each onto the outer legs about 20 cm (8 inches) up from the anchor plates.

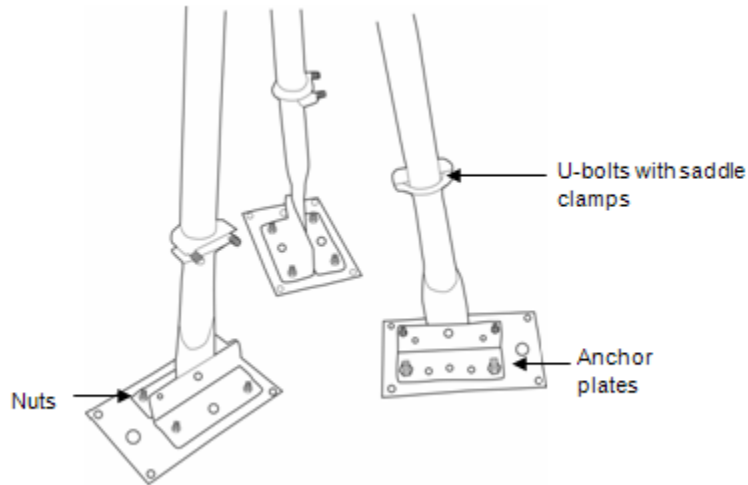

Figure 40: 3 meter lower tripod

3. Open the tripod and place it in an upright position.
4. Unfold the leg brace assembly and place the assembly flat on the ground.

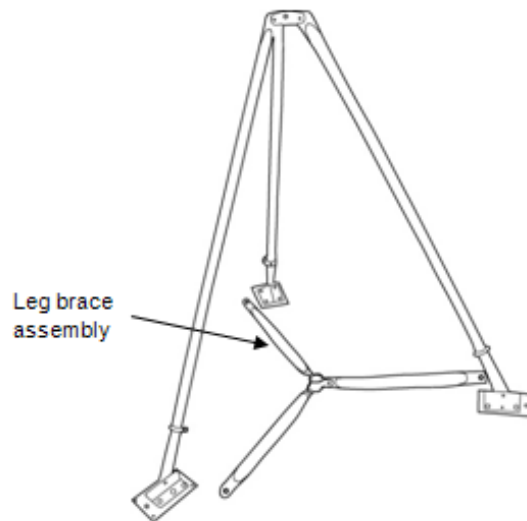

Figure 41: 3 meter tripod leg brace

- Attach each of the three inner legs to each of the leg U-bolt assemblies (5/16-18 inch) using the inner stud of the U-bolt. To attach each inner leg, remove the nut from the inner stud, slide the leg over the stud, and then tighten the nut finger.

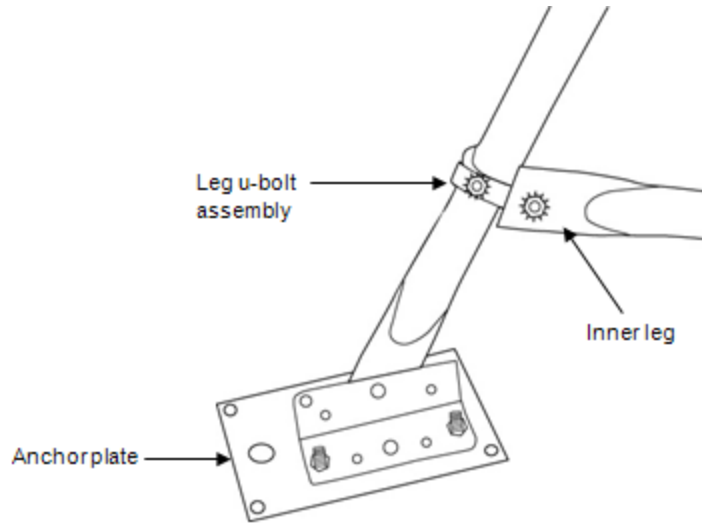

Figure 42: Three meter tripod inner leg

- Loosen the three lock nuts on the bolts on the upper and lower mast tri-clamp assemblies. Back the three bolts out of the upper and lower mast tri-clamp assemblies so that the lower mast section can be slipped down through the upper mast tri-clamps and into the lower mast tri-clamp with the creased end of mast facing up. When the lower mast section is installed, hand-tighten the upper and lower mast tri-clamps.

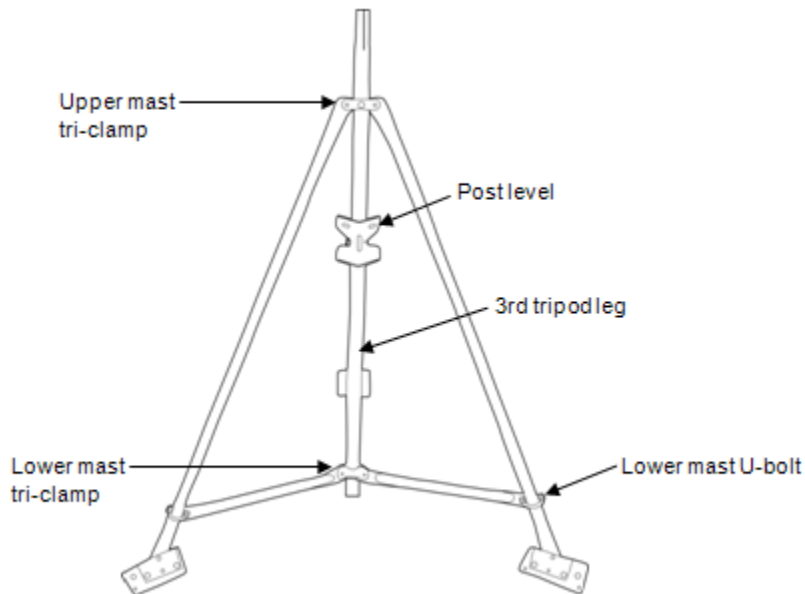

Figure 43: Three meter tripod lower mast

- Install a Post Level (Part # M-LVA) on the lower mast as shown in the previous figure.
- When the tripod is oriented on the site, secure one of the three tripod legs to its mounting location and tighten the U-bolts on this leg.
- Adjust the second leg to level in one direction and secure this leg.



10. Use the third leg to adjust the mast close to level.
11. When the mast is close to being level, secure the third leg.
12. Fine tune the mast level by sliding the U-bolts slightly up or down. Tighten all three leg tri-clamps using a 1/2 inch wrench. Again, verify that the mast is level.
13. After checking level and orientation, tighten all upper and lower mast U-bolts and lock nuts.
14. Orient the lower mast creases so they face north and south.
15. Tighten the tri-clamp bolts so that the mast is locked into position. Note the lower mast should be about 8 inches (20 cm) above the ground at this time (assuming that if you are using the wind sensor, you want it to end up at 3 meters or almost 10 feet).

## Task 2: Install Grounding Kit

---

This section explains how to install the grounding rod from the Grounding Kit (Part # M-GKA) and attach it to the lower mast of either the 2 meter and 3 meter tripods.

1. Attach the ground wire to the lower mast of the tripod using the U-bolt assembly delivered with the grounding kit.
2. Slide the ground rod clamp over the ground rod prior to driving it into the ground. This allows you to work with the clamp before the top of the rod is damaged from impact.
3. Using a sledgehammer, drive the ground rod into the ground as close as possible to the lower mast of the tripod.
4. Attach the ground wire to the ground rod. Cut off excess cable length and discard or recycle.
5. Tighten the clamp bolt.

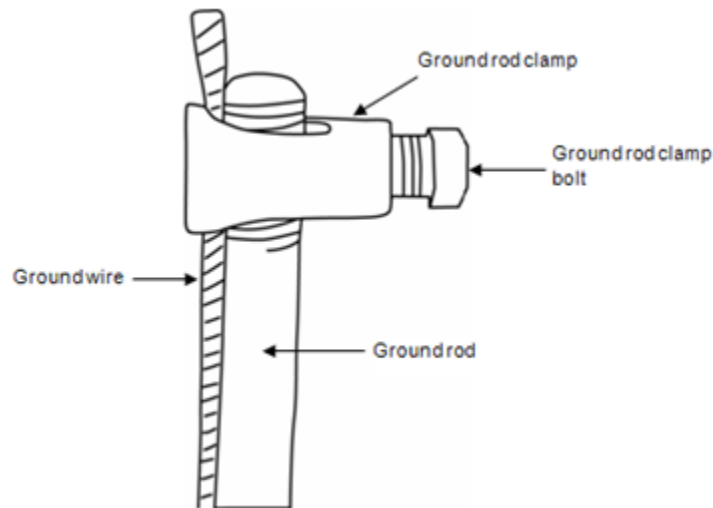

Figure 44: Ground wire attachment

## Task 3: Temporarily Install Upper Mast (Optional)

---

This section explains how to temporarily attach the upper mast to the tripod base. This allows you to easily work on the upper mast while it is resting on the base of the tripod.

**Note:** If you prefer to permanently install the upper mast at this point because you will be able to reach the fully assembled tower, go to Task 5 and then return to Task 4. Otherwise, follow these temporary steps and then permanently attach the upper mast later.

1. If you will be using the Guy Wire Kit (Part # M-GWA), install the guy wire upper mast clamp about two-thirds up the upper mast. Tighten the clamp by hand to temporarily hold it in place. You will need to adjust it later.
2. Stand the upper mast upright and tie a cable tie to one leg brace and one leg of the tripod using the cable ties supplied. Remove the cable ties after the cross arm and sensors are installed.

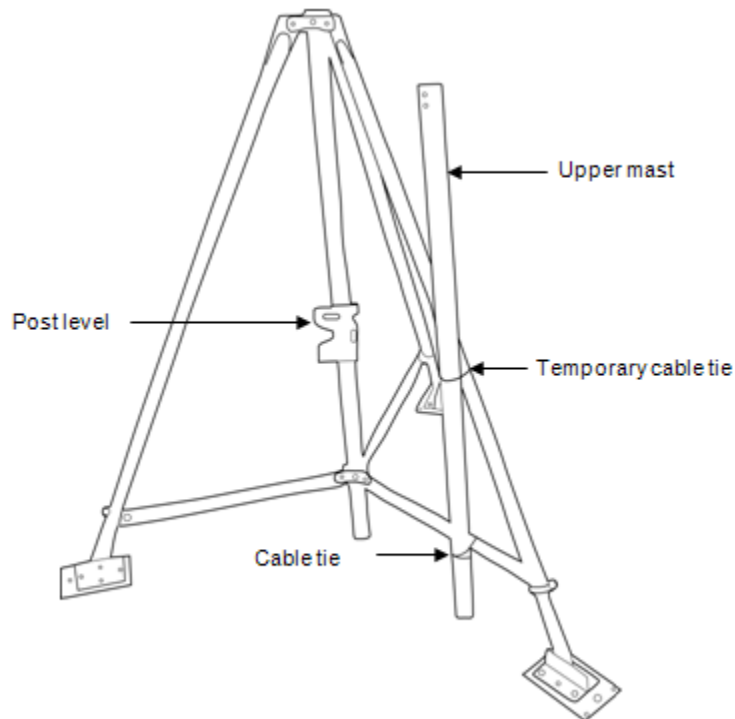

Figure 45: Upper mast (temporary)

## Task 4: Mount Cross Arm (Optional)

---

Onset recommends that you use an Onset cross arm to mount the Wind Speed or Wind Direction sensor because it keeps this sensor away from other sensors that could cause wind turbulence or wind shadows. It is also the best way to ensure the sensor is vertical.

### Steps

1. Attach the cross arm to the upper mast using the two 1/4-20 x 2-3/4 inch hex head bolts. Mount the cross arm on the side opposite the dimple (at the bottom of the upper mast) with the word "TOP" on the upper surface of the cross arm.
2. Pass the two bolts with flat washers on them through the two holes on the cross arm and through the two holes at the top of the upper mast. Install a nylock nut on each bolt. Do not securely tighten the bolts yet.
3. Install the mast plug into the upper mast top with the slot facing down and going over the two bolts. **Note:** After the mast plug is installed, it should be flush with the top of the mast.
4. Tighten the two nuts equally.

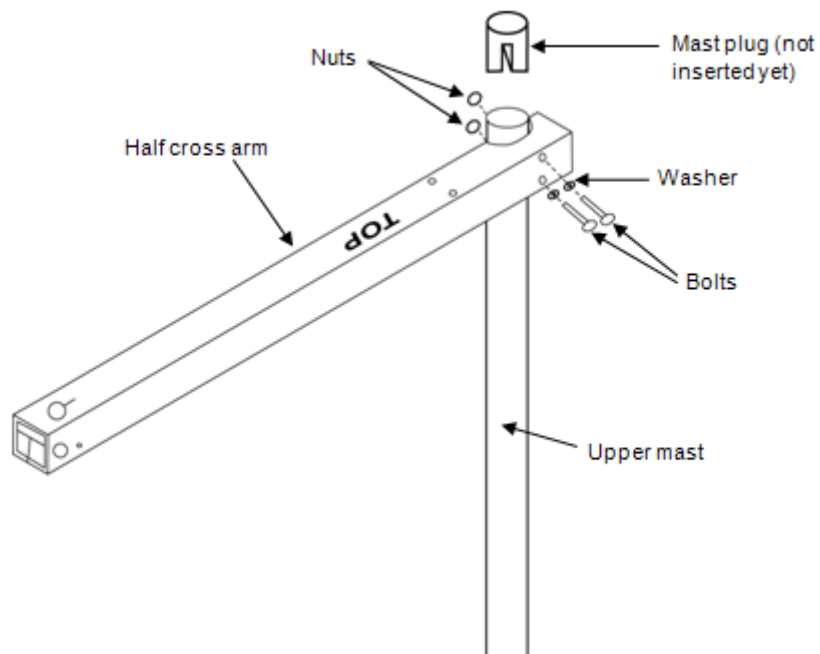

Figure 46: Half cross arm (setup is same for full cross arm)

For directions on mounting the Wind Speed or Wind Direction sensor to the cross arm, see the sensor manual.

## Task 5: Mount Upper Mast to Lower Mast

---

**NOTE:** Onset recommends that two people work together to attach the upper mast to the lower mast.

1. Lightly grease the creased (upper) end of the lower mast.
2. While holding the upper mast securely, cut the cable ties that were temporarily holding the upper mast to the lower mast.
3. Slide the upper mast onto the lower mast with the dimple going into the crease and oriented north if you are in the northern hemisphere, and south if you are in the southern hemisphere.
4. When the upper and lower masts are aligned, install the 1-5/8 inch U-bolt assembly onto the upper mast, placing it just above the dimple (about 2.5 cm or 1 inch from the upper mast bottom). Tighten the clamp.

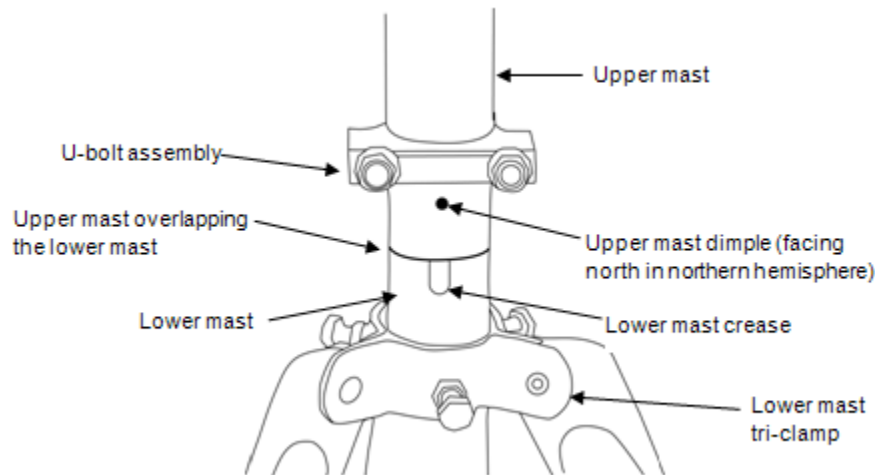

Figure 47: Upper and lower mast assembly

If you are using a Wind Speed sensor and have not attached the cross arm, go to Task 4: Mount Cross Arm (Optional) on page 95.

## Task 6: Mount Logger to Upper Mast

---

1. Using the two 1-5/8 inch U-bolt assemblies provided, mount the logger enclosure on the lower end of the upper mast in line with the upper mast dimple. The lower housing U-bolt can be placed directly above the U-bolt holding the mast pieces together.

**Note:** When assembling the U-bolts, place the U-bolts around the upper mast, and install the saddle clamp. Place the logger enclosure against the saddle clamps and screw on the top U-bolt nuts only.

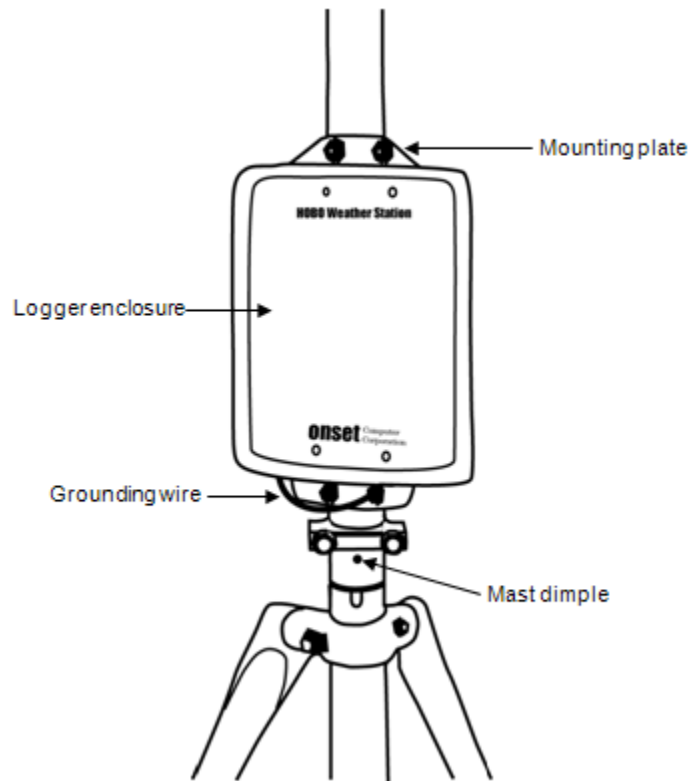

Figure 48: Logger Housing on Mast

2. If you are using the Guy Wire kit, position the logger enclosure so that it will not be in the way of guy wires.
3. Attach the logger's ground wire to the lower housing U-bolt. Screw on the lower U-bolt nuts and then tighten all the U-bolt nuts.

## Task 7: Install Guy Wire Kit (Optional)

**NOTE:** If you are using the 2 meter tripod, you will need to attach the guy wires to three 1/2 inch stakes (Part # M-SKA), which should be spaced evenly around the tripod at a distance of 3 to 4 m (10 to 13 ft) from the mast.

1. If you haven't already done so, attach the upper mast tri-clamp to the upper mast. Orient the eyebolts on the upper clamp so they align with each tripod foot or a 1/2 inch stake.
2. Attach one end of the guy cable to one eyebolt on the upper mast tri-clamp. Open the wire clamp by loosening the screw on it. Place the clamp over the wire and tighten. Leave 2.5 cm (1 inch) of wire protruding from the clamp.

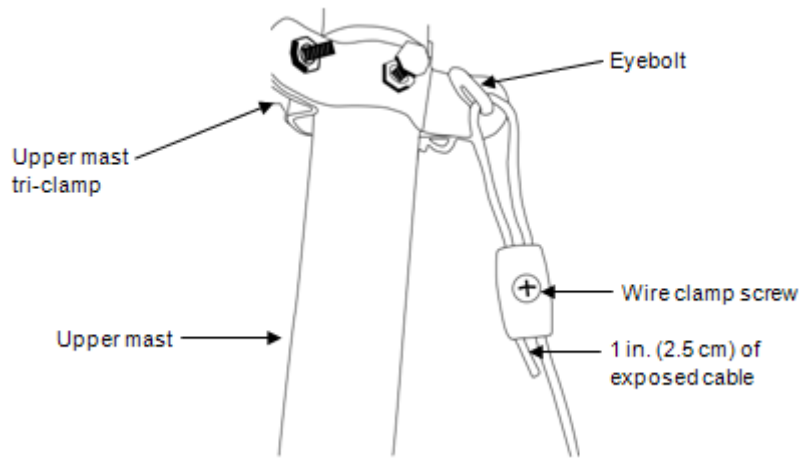

Figure 49: Guy wire attachment

3. Hook one "S" hook and one turnbuckle onto the corresponding stake or leg.

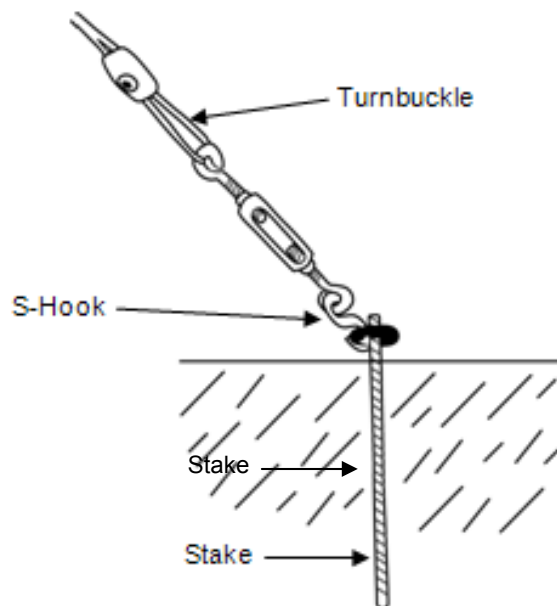

Figure 50: Guying to 1/2 inch Stakes

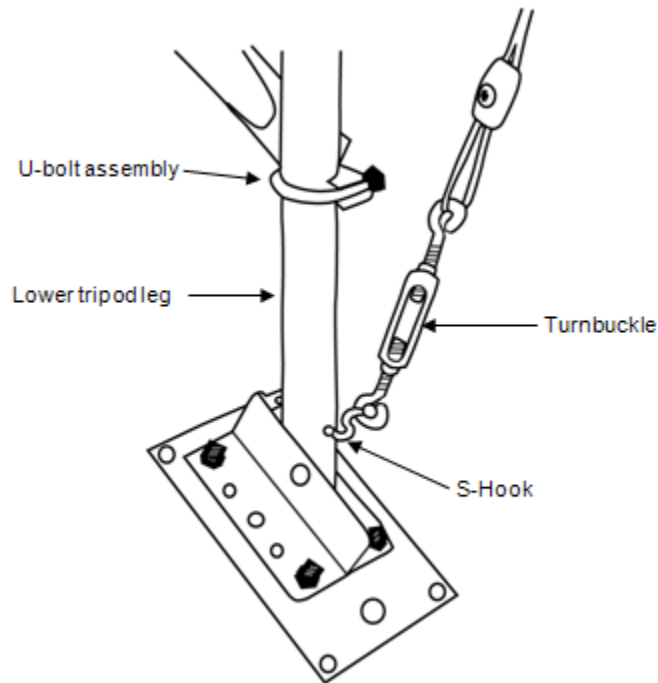

Figure 51: Guying to 3 Meter tripod feet

4. Cut the guy cable so that it can be put through the loose end of the turnbuckle and the wire clamp. Make sure the turnbuckle is extended as shown in the figures before feeding the cable through.
5. Install the hooks, turnbuckles, and cables onto the other two stakes or tripod legs.
6. Tighten the three guy wires evenly by turning the turnbuckles.
7. Attach a Post Level (Part # M-LVA) on the upper mast to maintain the mast at vertical.
8. The guy wires should be taut when the installation is complete.

## Task 8: Position and Level Sensors

---

Once the upper mast is locked in place and secured, position the sensors at the correct heights and check that the Rainfall sensor and PAR sensors are level. See the sensor manuals for more details.



## Task 9: Final Setup

---

1. Open the logger enclosure.
2. Pass all the sensor cable ends through the opening on the bottom of the logger enclosure.
3. Plug all the sensors with tabs facing up into the logger board located within the logger enclosure. It does not matter which connector you plug each sensor into. You can use a maximum of 15 channels and 100 meters (328 ft) of smart sensor cable.

**Note:** If you are installing more than ten sensors, you will need to install an adaptor (Part # S-ADAPT) for each additional sensor. The adaptors fit into any of the connectors on the logger board except the upper left connector and the connector second from the bottom on the right.

4. If you have a HOBO U-Shuttle or laptop on site, check current sensor readings to ensure the sensors are all working. For the HOBO Weather Station, note that you cannot check current readings if the logger is waiting for a Button Start or a Delayed Start.
5. Neatly wrap all the sensor cables together and secure to the mast or tripod legs using cable ties.
6. Gather the excess cable and attach the cable ties to the upper mast behind the logger. Leave about a 2 inch (5 cm) drip loop of cable below the logger.

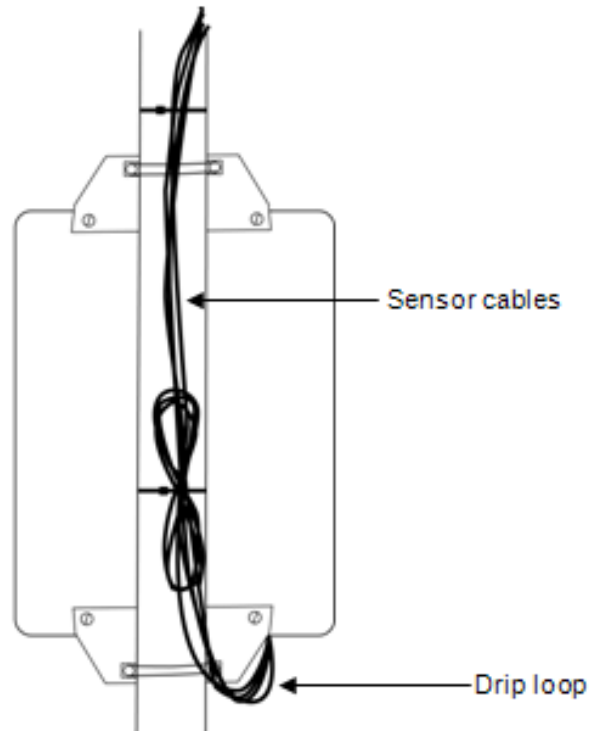

Figure 52: Sensor Cables on Mast

7. Seal logger enclosure (HOBO Weather Station Only).

**This step is especially important if the system is located in a wet environment.**

Once you verify that the cables are secured in the inside of the logger box, take all the cables and push them over to one side of the logger enclosure opening. Using the duct seal, make a ball that is bigger than the logger enclosure opening, stuff the duct seal into the hole from the outside, filling the void between the cables and the housing. This minimizes the possibility of dust, insects, and driving rain getting into the logger housing. Flare out the duct seal on the inside to lock it place.

All cables should be neatly secured to the mast when complete.

**NOTE:** If you are using a HOBO Weather Station in a wet environment, place several dry desiccant packs inside the logger enclosure (remove desiccant pack from its foil pouch before installing)

8. Recheck that all the U-bolts, nuts, and clamps are secure for the entire system.
9. If you are using a Weather Station, launch the logger now. The U30 is automatically launched when powered-up.
10. Verify that the logger is operating properly. Refer to the logger user manual for LED indications.
11. Close the logger door. For the HOBO Weather Station, tighten the four cover screws.

Congratulations! The HOBO Station setup is complete.