

## Antenna / Antena

Ref. 149481

### DAT<sup>HD BOSS</sup>790 MIX

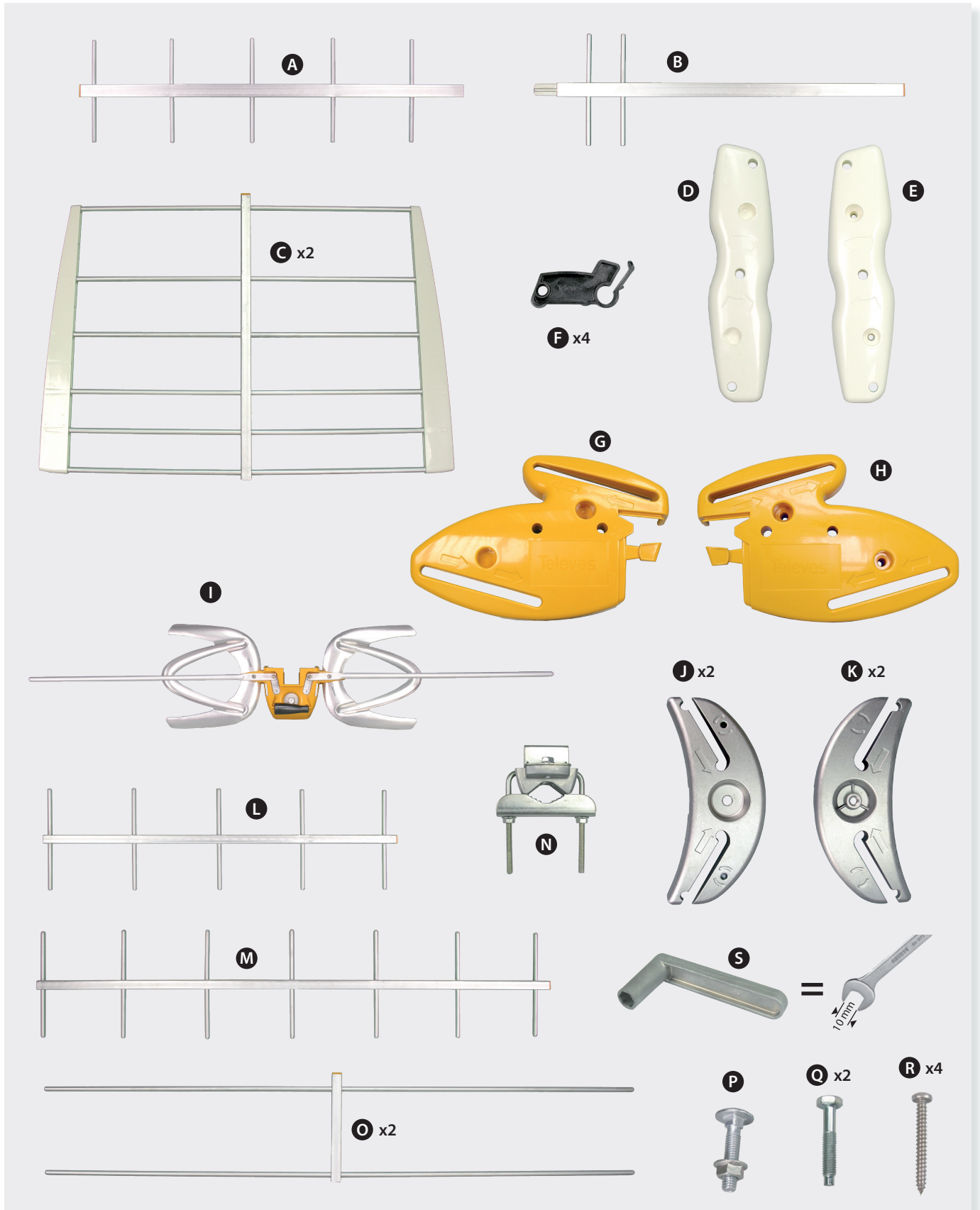

Antenna mounting / Montaje de la antena

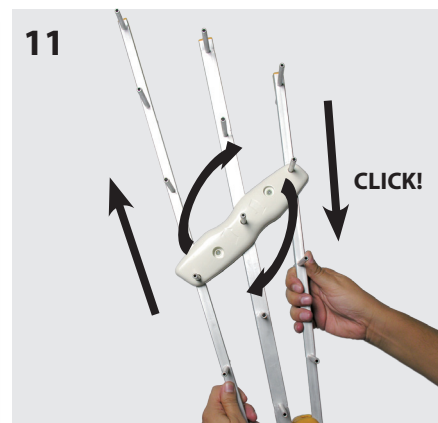
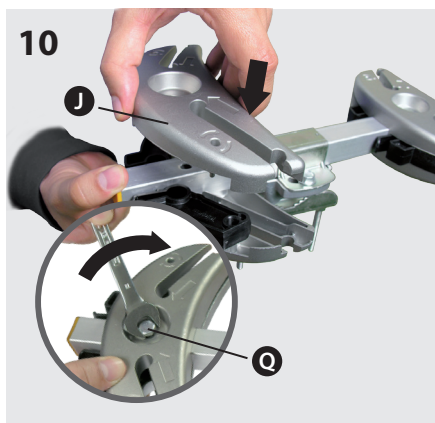
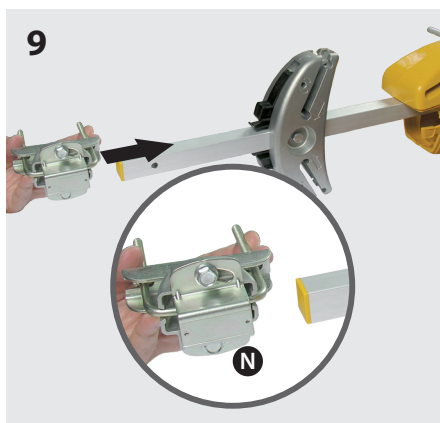
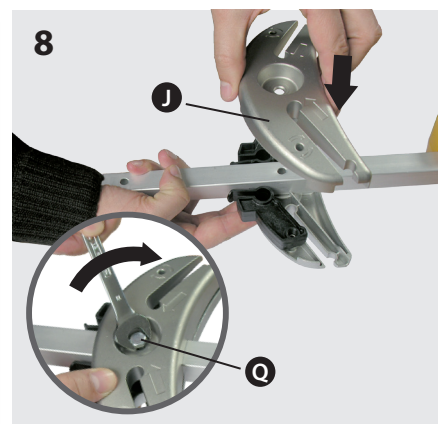
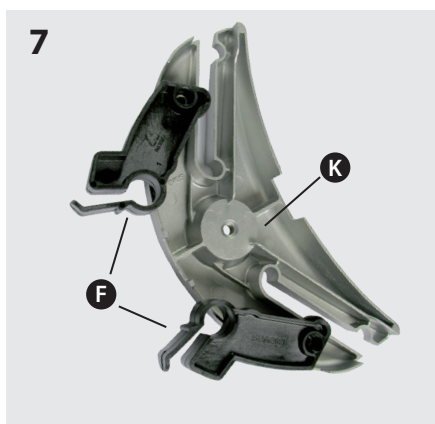
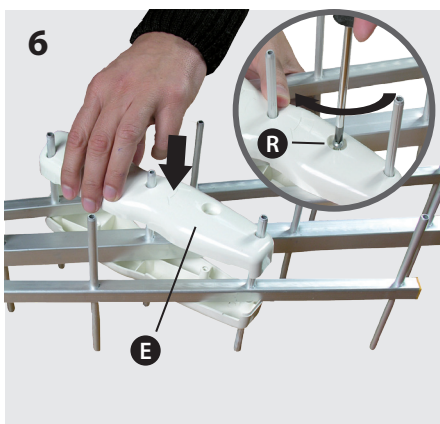
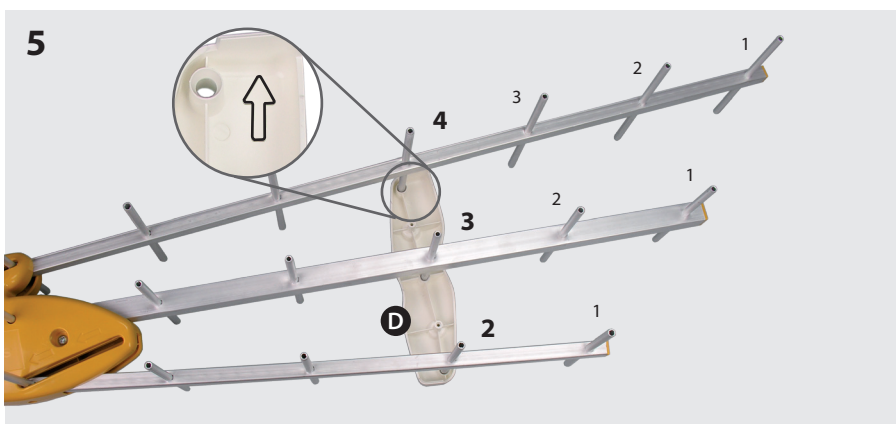
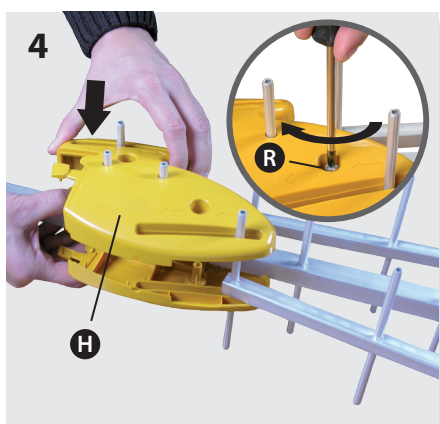
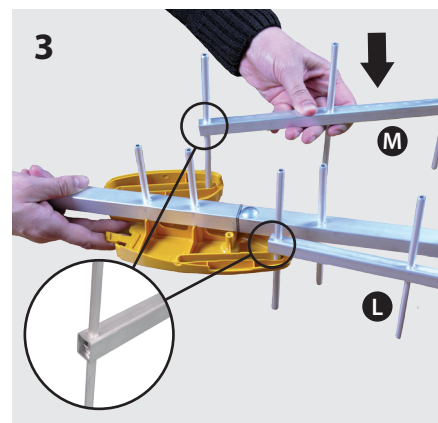
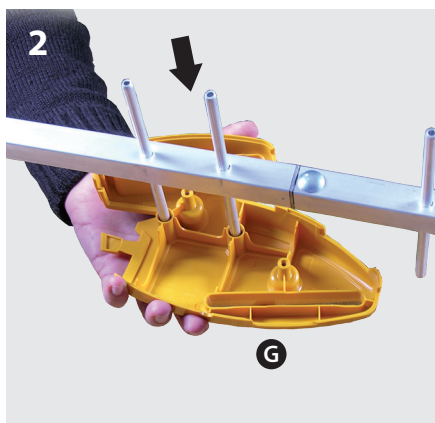
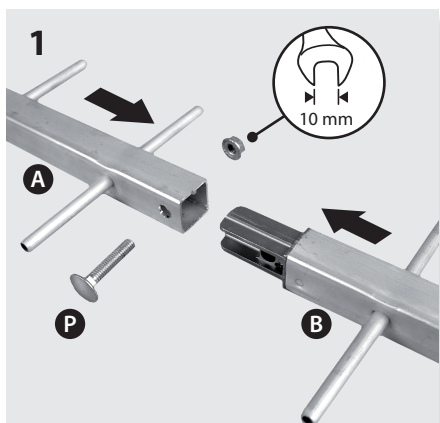

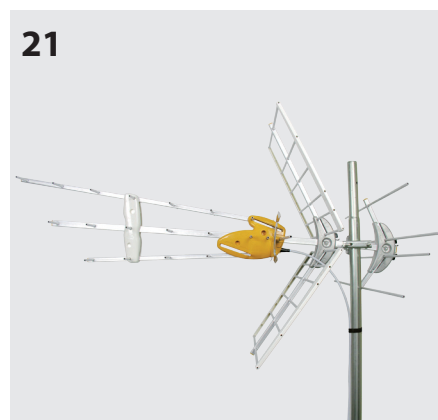
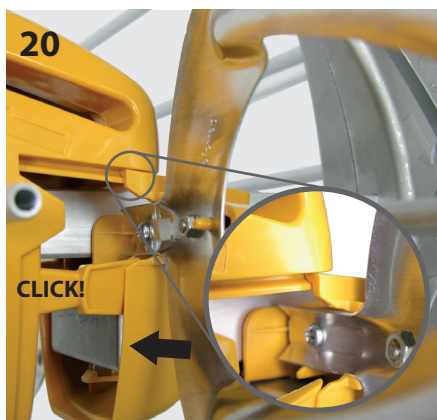
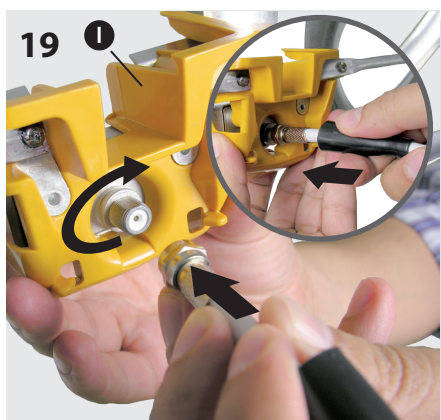
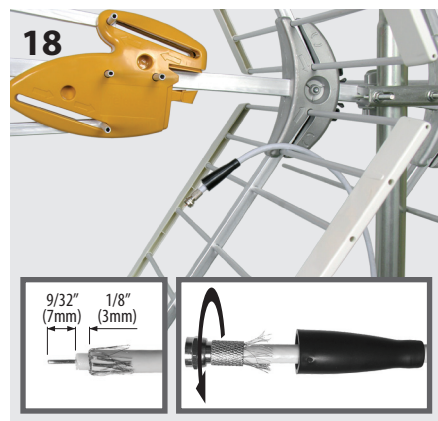
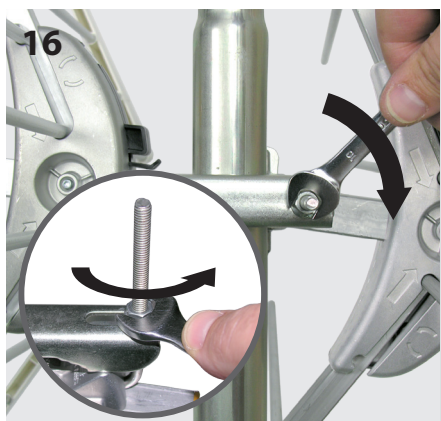
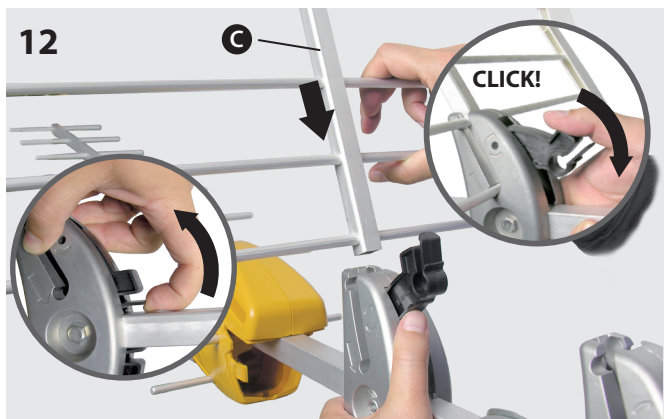

## Technical specifications / Características técnicas

Mode	Modo	MHz	Boss OFF (Passive)		Boss ON (Active)	
			High VHF 174 - 216	UHF 470 - 698	High VHF 174 - 216	UHF 470 - 698
Operating band	Banda de trabajo	MHz	High VHF 174 - 216	UHF 470 - 698	High VHF 174 - 216	UHF 470 - 698
Gain	Ganancia	dBi	8.5	16	21 max.*	31 max.*
Output level	Nivel de salida		----		Auto*	
Noise figure	Figura de ruido	dB	----		2 typ	
Power supply	Tensión de limentación	Vdc	0		12 - 24	
Consumption	Consumo	mA	----		40 max	
Beamwidth	Ancho de haz	°	30			
Wind load	Carga al viento	N	120 (@ 80 miles/h) 165 (@ 93 miles/h)			

\*The gain is automatically adjusted according to the output level / La ganancia varía automáticamente en función del nivel de salida.

### Safety Instructions:

#### LIGHTNING PROTECTION

- ◆ If installed outdoors, be sure the antenna system is grounded so as to provide protection against voltage surges and built-up static charges. Section 810 of the National Electrical Code ANSI/NFPA70, or CSA C22.1 sections 10, 16, and 54, of the Canadian Electrical Code, provide information with respect to proper grounding of the mast and supporting structure, grounding of the antenna lead-in wire to an antenna discharge unit, size of grounding conductors, location of antenna-discharge unit, connection to grounding electrodes, and requirements for the grounding electrode (see figure and instructions).
- ◆ Mount the lightning arrester or 75 ohm coaxial grounding block as close as possible to where the 75 ohm coaxial cable downlead enters the house.
- ◆ The ground wires for both the mast and the downlead should be copper or aluminum wire, number eight (8) or larger.
- ◆ The downlead wire from the antenna to the lightning arrester and the mast ground wire should be secured to the house, spaced from four (4) to six (6) feet apart.
- ◆ In the case of a "ground up" antenna installation it may not be necessary to ground the mast if the mast extends four or more feet in the earth. Consult a TV serviceman for the proper depth in your location.

#### WARNINGS

- ◆ To prevent fire or shock hazard, do not expose the included power supply to rain or moisture.
- ◆ Installation of off-air antennas near power lines is dangerous. For your safety, follow the installation instructions.
- ◆ Any alteration or modification to the product or usage not in accordance with product instructions voids the warranty.

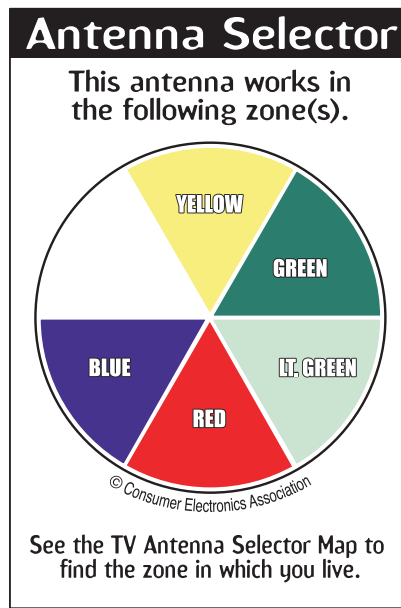
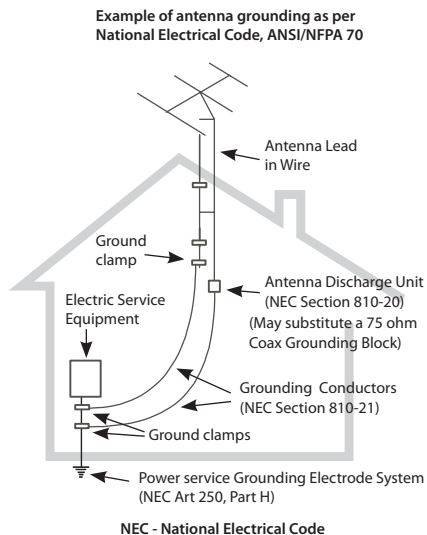

### High-VHF

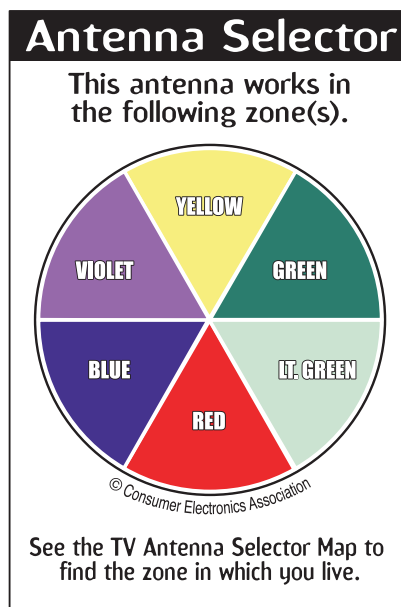
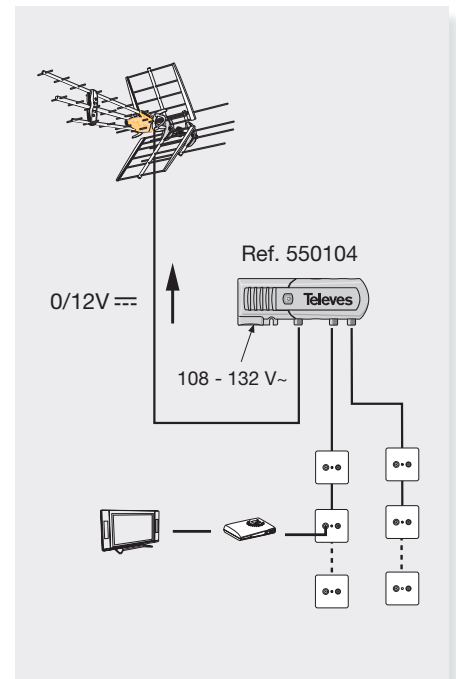

### UHF

