

Ergotron® Tablet Management Carts and Desktop Module

Dimensional Illustrations

Tablet Management Carts



205 Westwood Ave, Long Branch, NJ 07740
 Phone: 866-94 BOARDS (26273) / (732)-222-1511
 Fax: (732)-222-7088 | E-mail: sales@touchboards.com

Front View

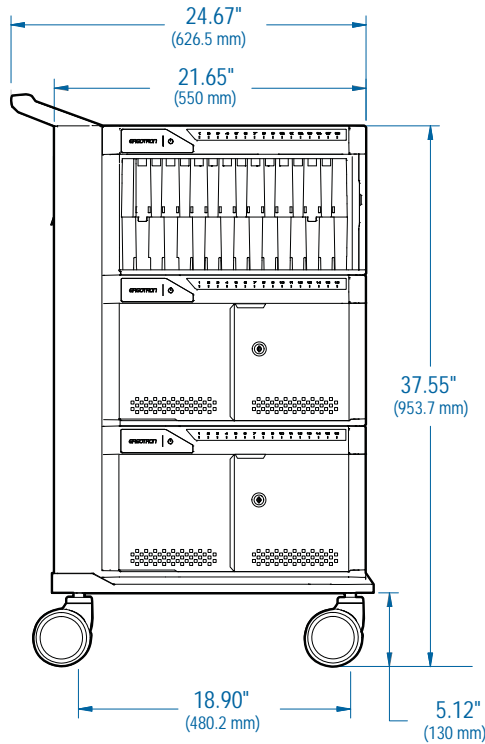

Right Side View

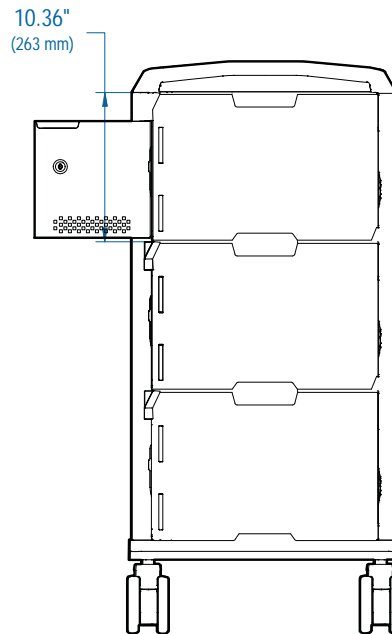

Left Side View

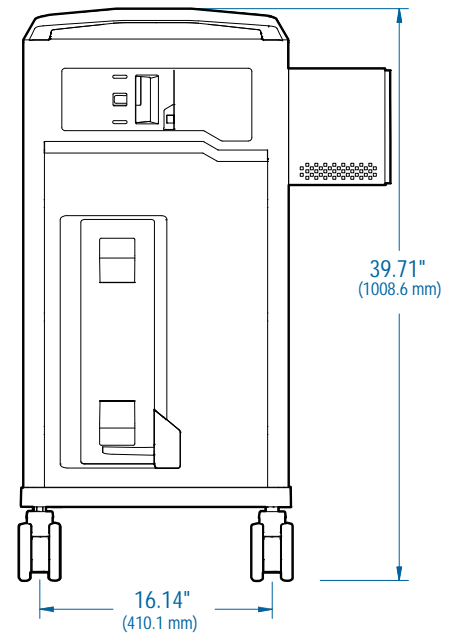

Top View

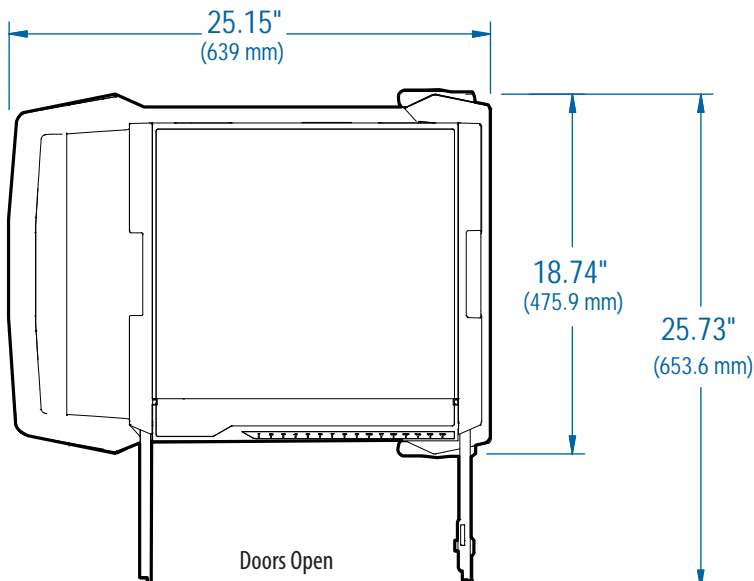

Tablet Cart with Two or Three Modules

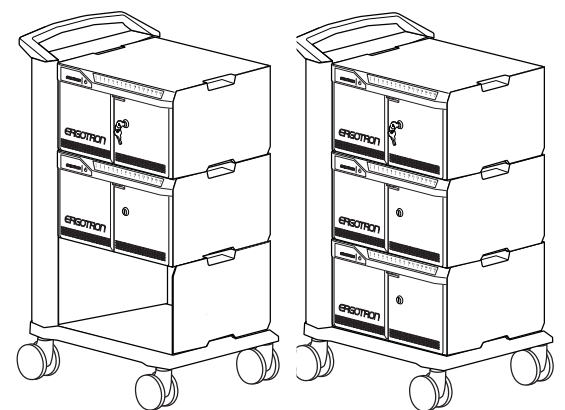

Ergotron® Tablet Management Carts and Desktop Module

Desktop Module

Front View

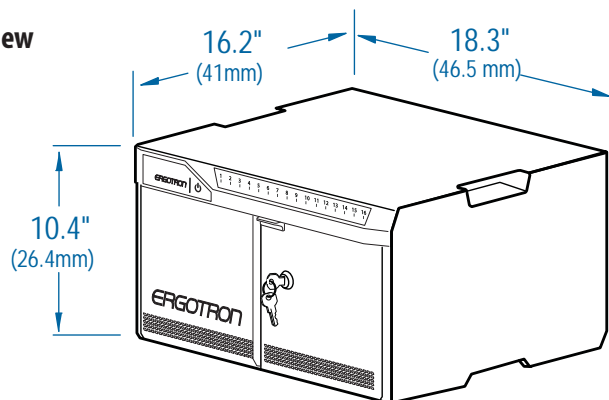

Rear View

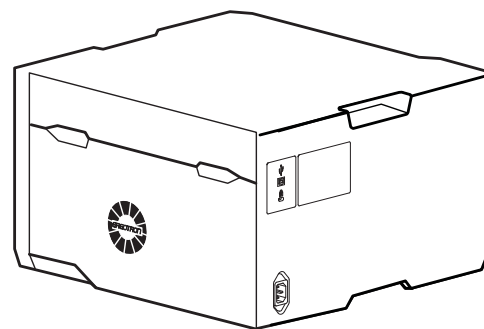

Individual Slot Size

- 7.9" H x 11.3" D x 0.85" W (20.0 x 28.8 x 2.2 cm)
- Individual tablet weight: up to 2.2 lb (1 kg)

NOTE: Tablet, power cord, and any cover or case must fit with these dimensions.

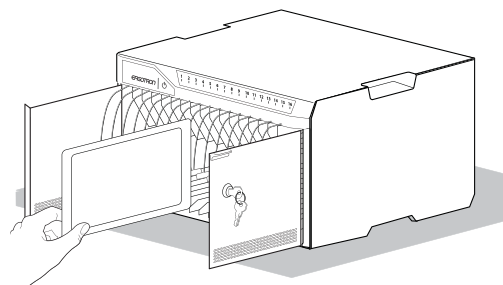
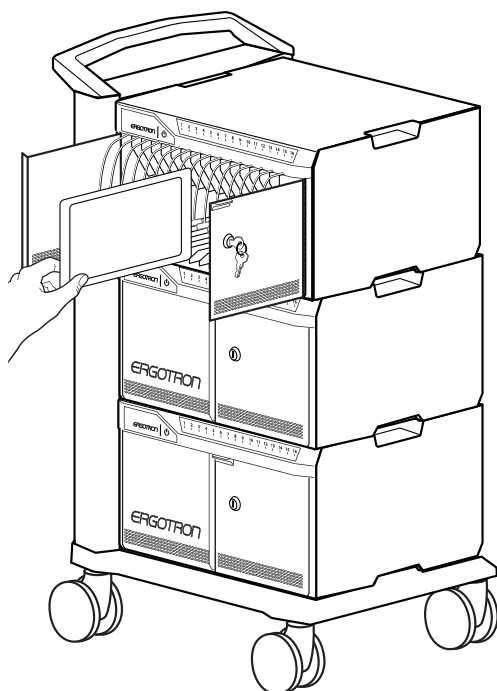

Americas Sales and Corporate Headquarters

St. Paul, MN USA
(800) 888-8458
+1-651-681-7600
www.ergotron.com
sales@ergotron.com

EMEA Sales

Amersfoort, The Netherlands
+31 33 45 45 600
www.ergotron.com
info.eu@ergotron.com

APAC Sales

Tokyo, Japan
www.ergotron.com
apaccustomerservice@ergotron.com

Worldwide OEM Sales

www.ergotron.com
info.oem@ergotron.com

