

Ergotron® Tablet Management Carts and Desktop Module

Dimensional Illustrations



205 Westwood Ave, Long Branch, NJ 07740
 Phone: 866-94 BOARDS (26273) / (732)-222-1511
 Fax: (732)-222-7088 | E-mail: sales@touchboards.com

Tablet Management Carts

Front View

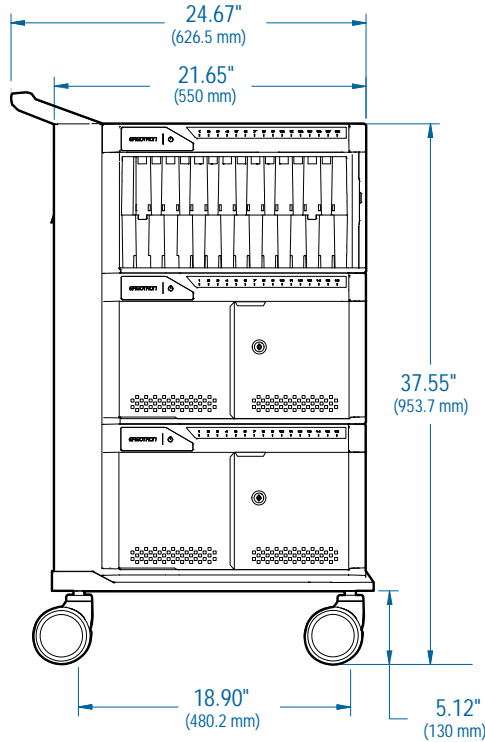

Right Side View

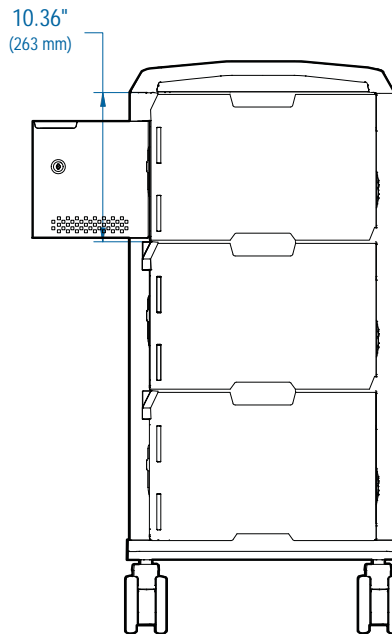

Left Side View

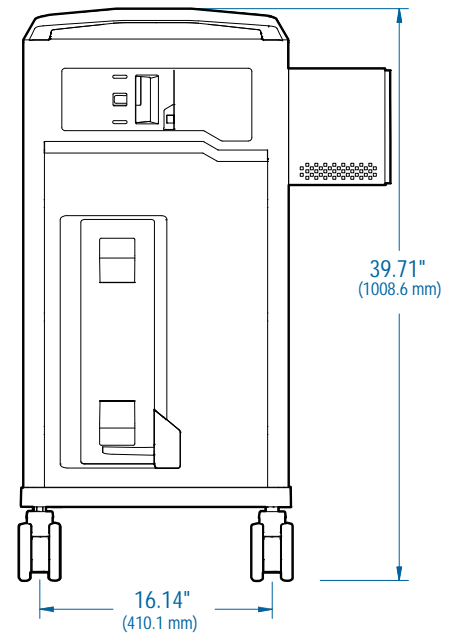

Top View

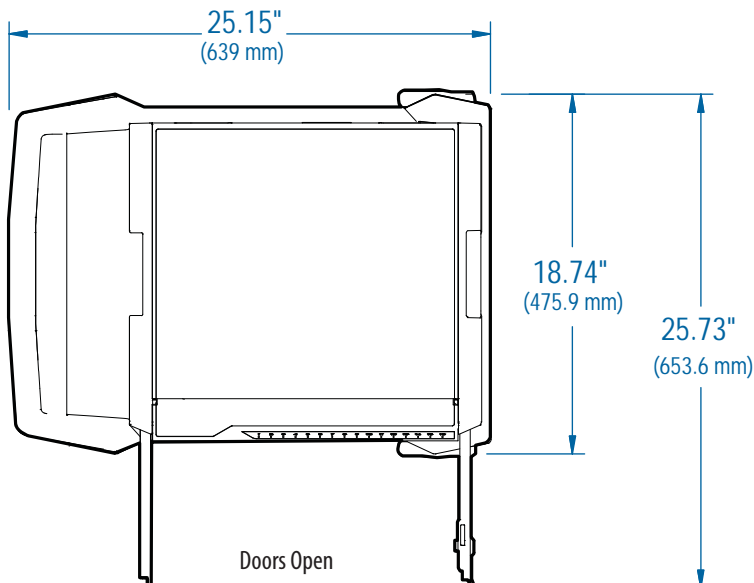

Tablet Cart with Two or Three Modules

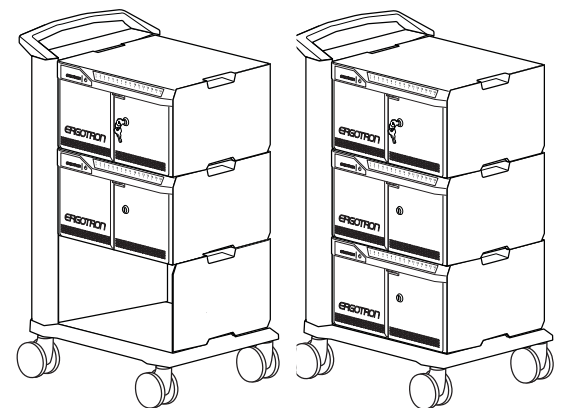

Ergotron® Tablet Management Carts and Desktop Module

Desktop Module

Front View

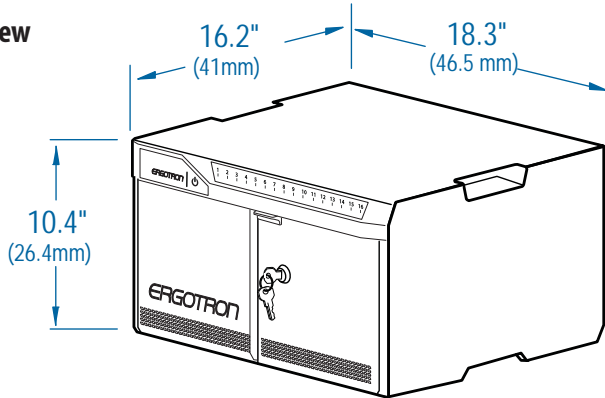

Rear View

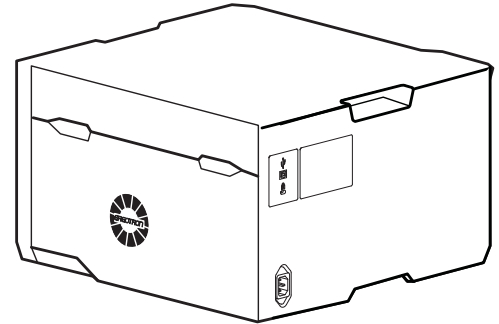

Individual Slot Size

- 7.9" H x 11.3" D x 0.85" W (20.0 x 28.8 x 2.2 cm)
- Individual tablet weight: up to 2.2 lb (1 kg)

NOTE: Tablet, power cord, and any cover or case must fit with these dimensions.

