



WorkFit-B, LD

Touchboards

For service and warranty visit www.ergotron.com
 Si desea información de servicio y garantía, visite www.ergotron.com
 Pour toute question concernant la garantie ou le service client, consultez www.ergotron.com
 Weitere Informationen zu Service und Gewährleistung erhalten Sie unter www.ergotron.com.
 Ga voor service en garantie naar www.ergotron.com
 Per assistenza e la garanzia visitate www.ergotron.com
 Gå in på www.ergotron.com för service och garanti
 サービスおよび保証について詳しくは、www.ergotron.com をご覧ください。
 有关服务和保修，请访问 www.ergotron.com

205 Westwood Ave, Long Branch, NJ 07740
 Phone: 866-94 BOARDS (26273) / (732)-222-1511
 Fax: (732)-222-7088 | E-mail: sales@touchboards.com

www.ergotron.com
 USA 1-800-888-8458
 Europe +31 (0)33-45 45 600
 China 86-769-86018920

www.ergotron.com

User's Guide - English
 Guía del usuario - Español
 Manuel de l'utilisateur - Français
 Gebruikersgids - Nederlands
 Benutzerhandbuch - Deutsch
 Guida per l'utente - Italiano
 Användarhandbok - svenska
 ユーザーガイド : 日本語
 用户指南 : 汉语

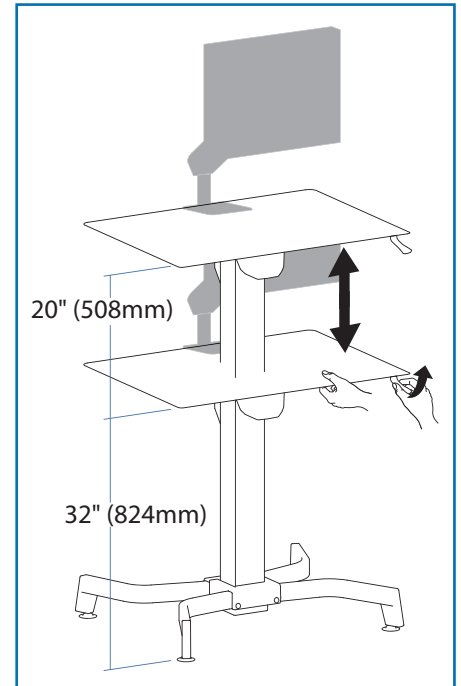
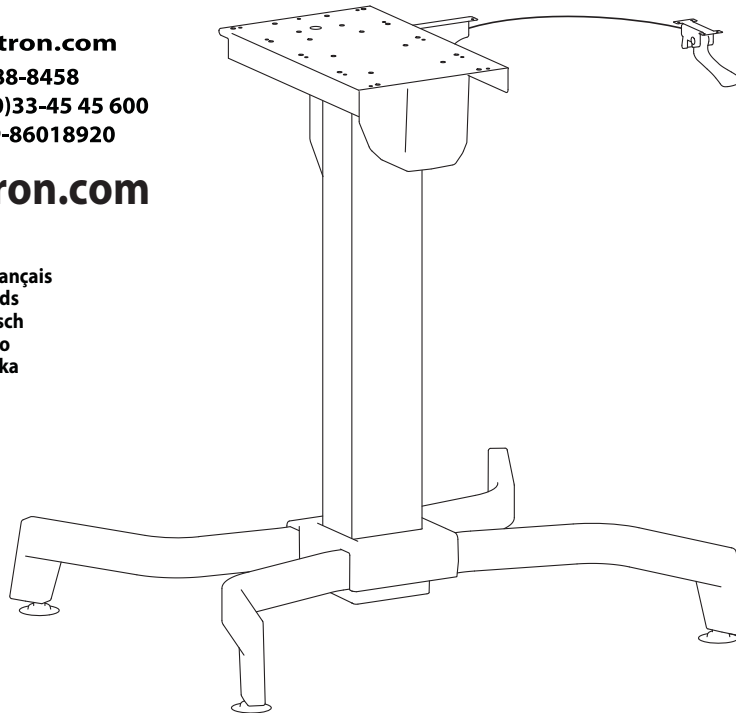

RECTANGLE SHAPED WORKSURFACE

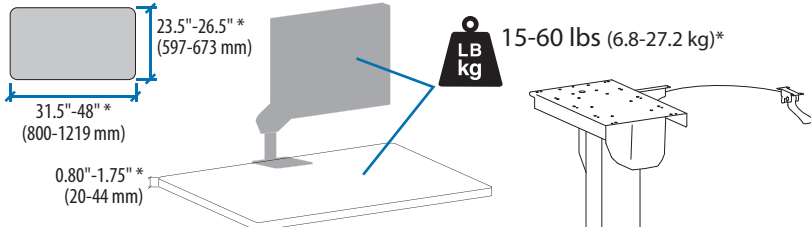

OTHER SHAPED WORKSURFACE

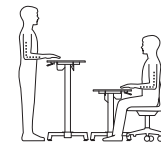
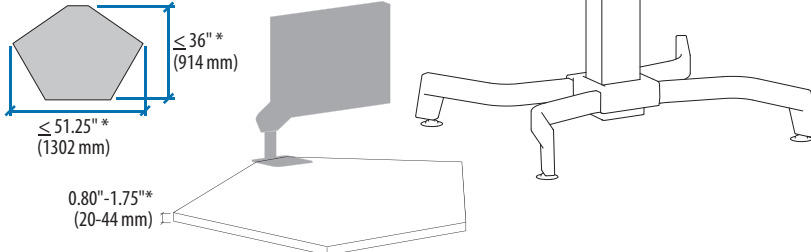

Important! You will need to adjust this product after installation is complete. Make sure all your equipment is properly installed on the product before attempting adjustments. This product should move smoothly and easily through the full range of motion and stay where you set it. If movements are too easy or difficult or if product does not stay in desired positions, follow the adjustment instructions to create smooth and easy movements. Depending on your product and the adjustment, it may take many turns to notice a difference. Any time equipment is added or removed from this product, resulting in a change in the weight of the mounted load, you should repeat these adjustment steps to ensure safe and optimum operation.





*Total weight of work surface and mounted equipment must be ≤ 60 lbs (27.2 kg). Work surface must meet ALL dimensional and weight range specification requirements.

WARNING! The addition of accessories can negatively impact the tip performance.

Wood Worksurface Weight Estimator	
Worksurface Thickness	Estimated Weight per square foot
0.80" (20 mm)	2.9 lbs (1.32 kg)
1.25" (32 mm)	4.5 lbs (2.04 kg)
1.75" (44 mm)	6.3 lbs (2.86 kg)

Hazard Symbols Review

These symbols alert users of a safety condition that demands attention. All users should be able to recognize and understand the significance of the following Safety Hazards if encountered on the product or within the documentation. Children who are not able to recognize and respond appropriately to Safety Alerts should not use this product without adult supervision!

Symbol	Signal Word	Level of Hazard
	NOTE	A NOTE indicates important information that helps you make better use of this product.
	CAUTION	A CAUTION indicates either potential damage to hardware or loss of data and tells you how to avoid the problem.
	WARNING	A WARNING indicates either potential for property damage, personal injury, or death.
	ELECTRICAL	An Electrical indicates an impending electrical hazard which, if not avoided, may result in personal injury, fire and/or death.

Safety

⚠ WARNING

IMPACT HAZARD

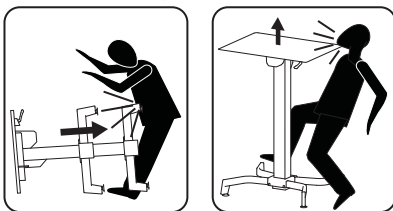

MOVING PARTS CAN CRUSH & CUT

Do not remove the zip tie and cardboard spacer which keep the hand brake from disengaging until instructed to in the manual. Removing the zip tie before the cart is unpacked and standing upright may cause unintended motion of the riser. Failure to heed this warning may lead to personal injury or equipment damage.

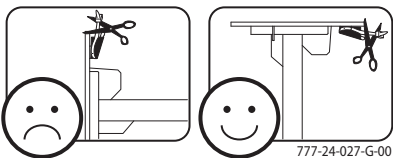

777-24-027-G-00

⚠ WARNING

IMPACT HAZARD

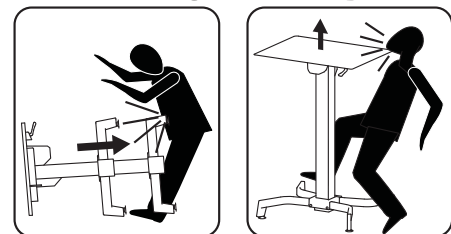

MOVING PARTS CAN CRUSH & CUT

Stop screw is pre-installed in this product to secure it in the compressed position during shipping and installation. DO NOT remove THIS screw until instructed to do so. Failure to follow these instructions may cause lift equipment to expand rapidly and may result in equipment damage and or personal injury.

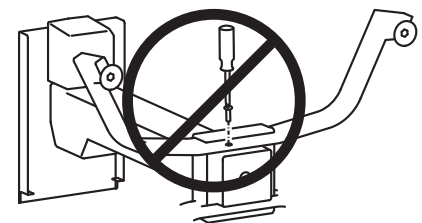

777-24-042-G-00

⚠ WARNING

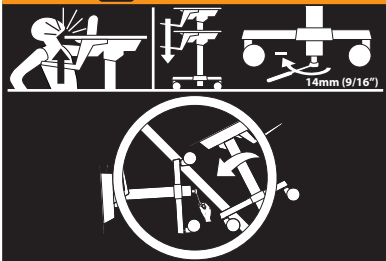

14mm (9/16")

IMPACT HAZARD!

MOVING PARTS CAN CRUSH AND CUT.

Minimize Lift Tension BEFORE:

- Removing Mounted Equipment.
- Shipping Cart
- Storing Cart

To Minimize Lift Tension

1. Lower worksurface to lowest position.
2. Turn adjustment nut at bottom of riser counterclockwise until it stops (Adjustment may require 40-60 revolutions).

Failure to heed this warning may result in serious personal injury or property damage!

For More Information and Instructions refer to product guide at www.ergotron.com or contact Ergotron Customer Care at 1-800-888-8458. 822-634



WARNING! TIPPING HAZARD!
When mounting accessories to this product, they must stay within the foot print. Do not mount accessories past the front and rear worksurface! Failure to follow this warning may result in equipment damage and or personal injury.

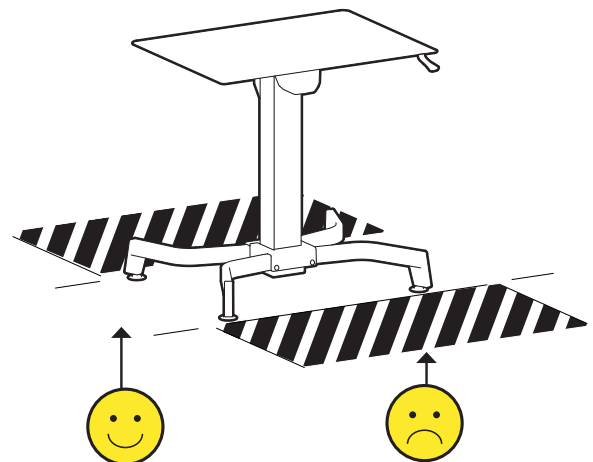

Safety



WARNING! Stop screw is pre-installed in this product to secure it in the compressed position during shipping and installation. **DO NOT REMOVE THIS SCREW UNTIL INSTRUCTED TO DO SO IN THESE INSTRUCTIONS.** Make sure this screw is in place before starting installation. Failure to follow these instructions may cause lift engine to expand rapidly and may result in equipment damage and or personal injury. If the phillips head stop screw is not installed in this location, contact customer care before continuing with installation.



IMPORTANT!

Save this stop screw and instructions. Install stop screw when shipping or storing this product. Failure to follow these instructions may cause lift engine to expand rapidly and may result in equipment damage and or personal injury.

DO NOT REMOVE SCREW UNTIL INSTRUCTED TO DO SO ON PAGE 11.

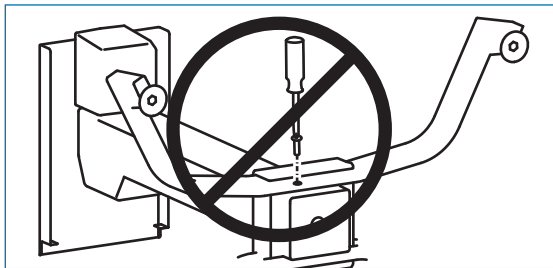

WARNING IMPACT HAZARD

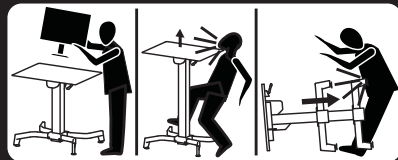

Minimize Lift Strength BEFORE:

- Removing Mounted Equipment
- Shipping the Cart
- Storing the Cart

Install Stop Screw BEFORE:

- Shipping the Cart
- Storing the Cart

To Minimize Lift Strength and Install Stop Screw:

1. With cart upright, lower worksurface to lowest position.
2. Turn adjustment nut at bottom of riser counter-clockwise until it stops (Adjustment may require 40-60 revolutions).
3. Install Stop Screw. Follow Installation Instructions provided with Cart.

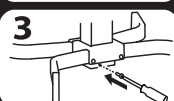
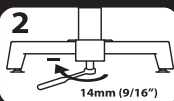
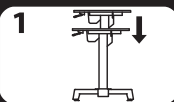

Failure to heed this warning may result in serious personal injury or property damage!



Cart Must Remain Upright whenever Stop Screw is not installed. Tipping the cart on its side without Stop Screw installed may cause the work surface to disengage and cause serious personal injury and property damage.

For More information and instructions refer to product guide at www.ergotron.com or contact Ergotron Customer Care at 1-800-888-8458. 827-178-00

Components



	A	B	C
1	1x 	1x 	16x #12-14 x 5/8"
2			4x ST3.9 x 16mm
3			
4	1x 	2x 	1x M2.9 x 7mm

Tools Needed

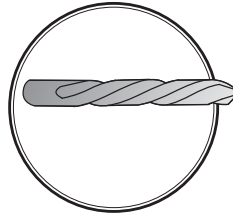
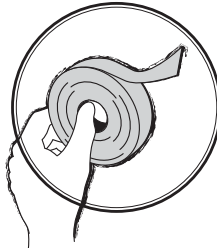
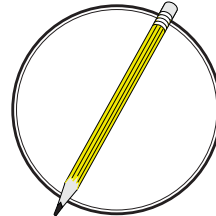
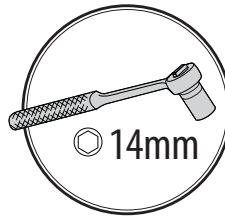
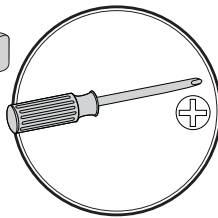
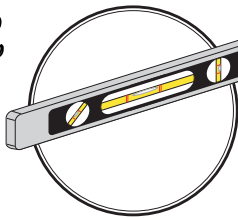

- Ø 1/8" (3 mm)
- Ø 5/32" (4 mm)
- Ø 1/4" (6.5 mm)
- Ø 15/32" (12 mm)

Set-up Steps

1

RECTANGLE SHAPED WORKSURFACE



Place template on bottom of work surface.

1. From side-to-side, align the center mark on the template with the center of the work surface to ensure maximum stability.
2. From front-to-back, place the center mark on the template $13\frac{5}{32}$ " (334 mm) from the front of the worksurface.

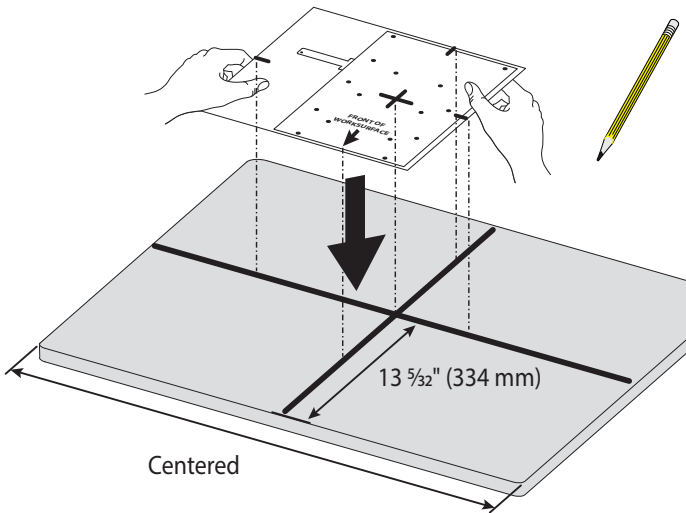

OTHER SHAPED WORKSURFACE

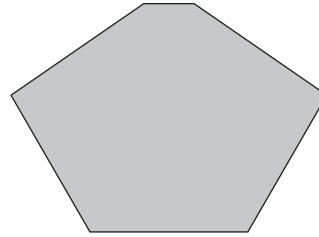

Place template on bottom of work surface.

1. From side-to-side, align the center mark on the template with the center of the work surface to ensure maximum stability.
2. From front-to-back, place the center mark on the template $18\frac{7}{8}$ " (480 mm) from the back of the worksurface.

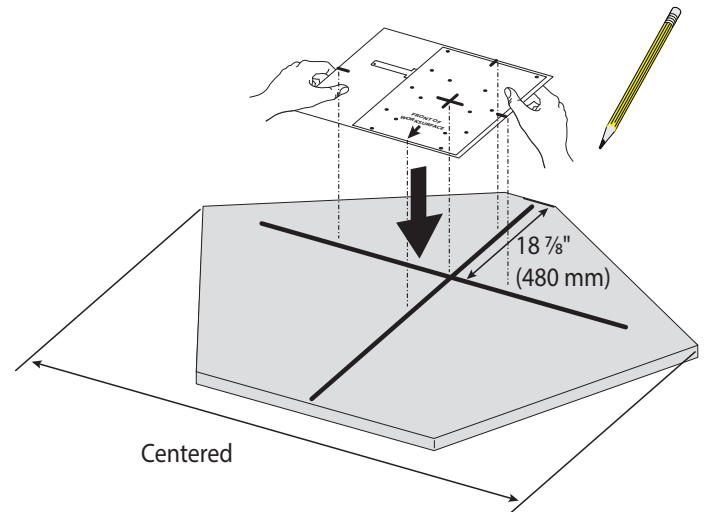

Set-up Steps

- 2** Make sure template is located properly and that it is square with the work surface. Then tape the template in place.

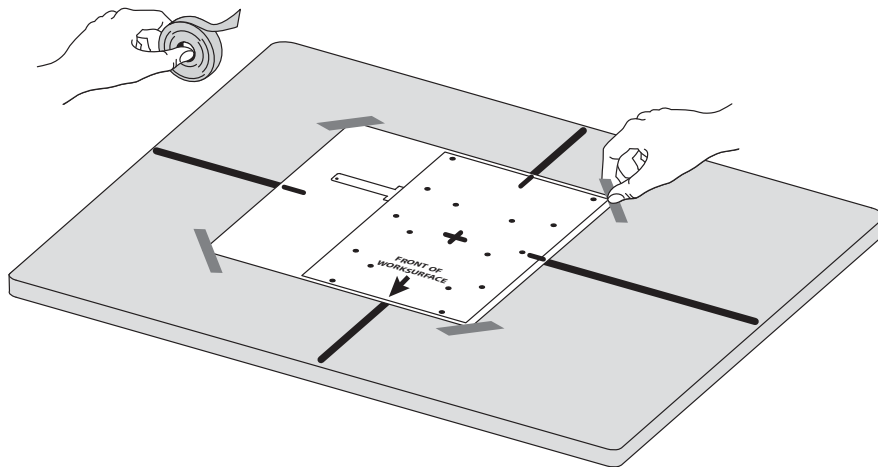

- 3** Mark holes with a center-punch, then drill holes into bottom of work surface.

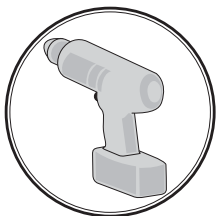

- a** Drill the 16x holes into bottom of work surface 3/8" (10 mm) deep.
TIP: To ensure proper depth, place a piece of tape on the drill bit 3/8" (10 mm) from the tip.

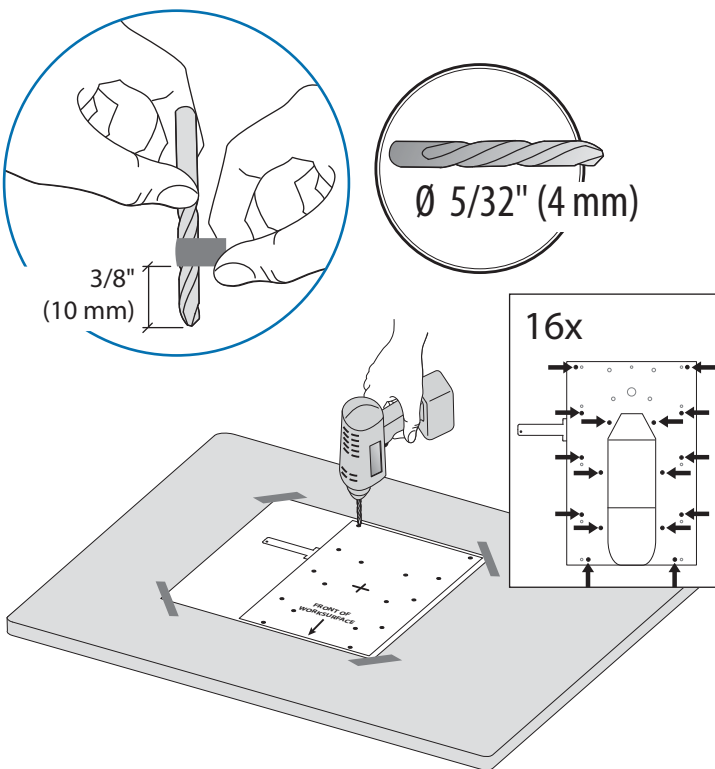

- b** Drill this 1x hole into bottom of work surface 5/32" (4 mm) deep.
TIP: To ensure proper depth, place a piece of tape on the drill bit 5/32" (4 mm) from the tip.

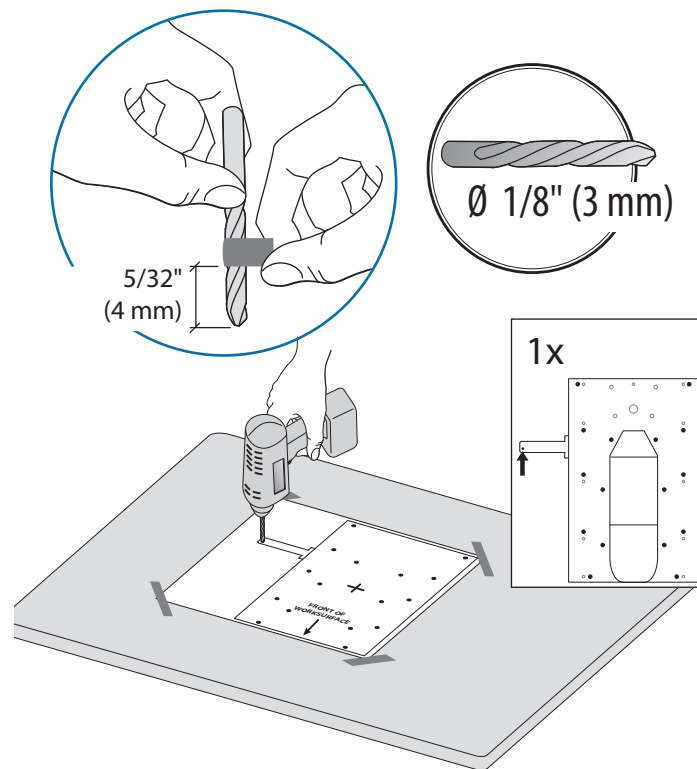

Set-up Steps

ONLY if you plan to attach any of the WorkFit PD Accessories, mark holes with a center-punch, the drill those holes through the work surface.
TIP: Place something under the worksurface so you don't drill into the surface underneath when you drill these through holes.

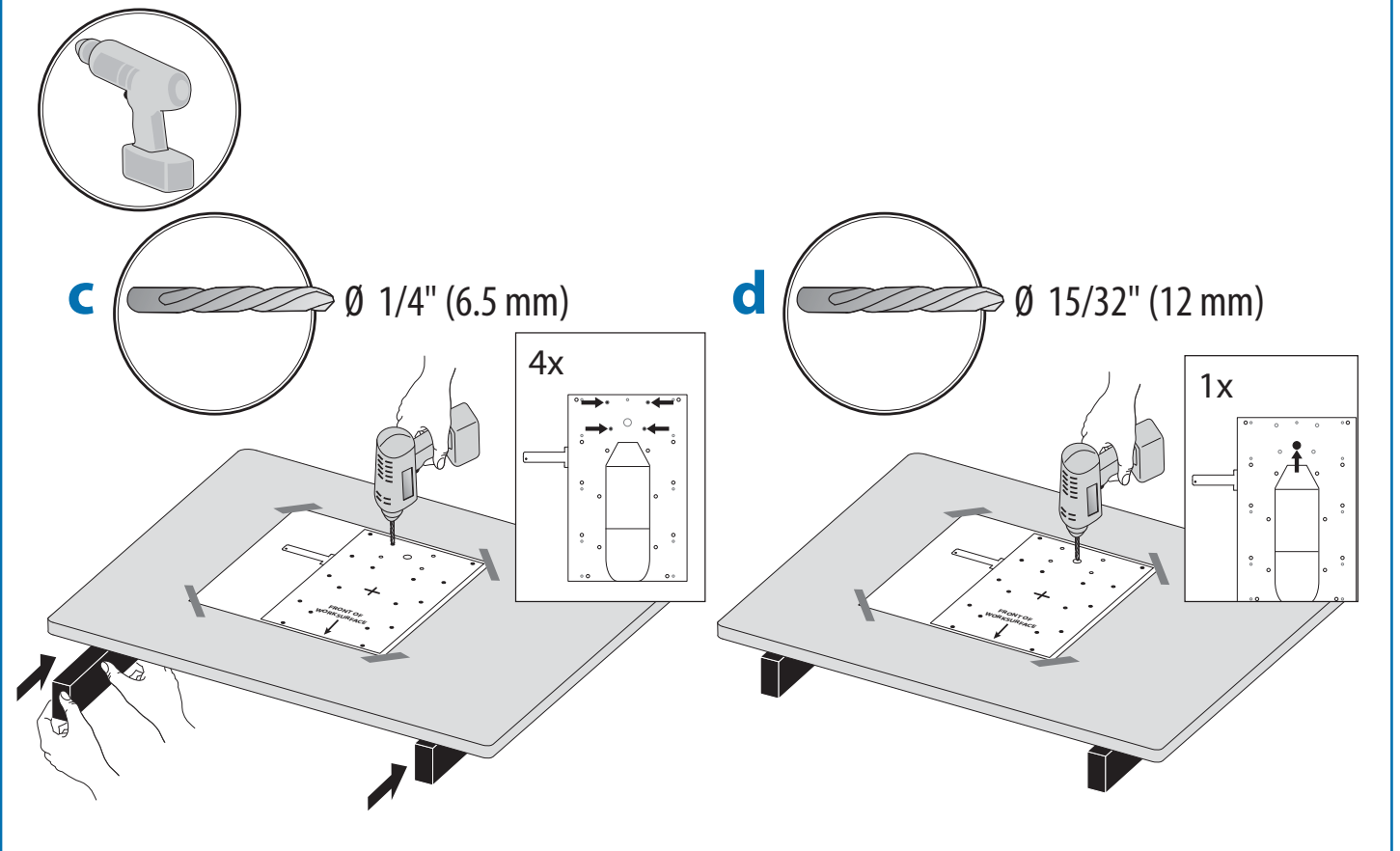

4 Remove the template.

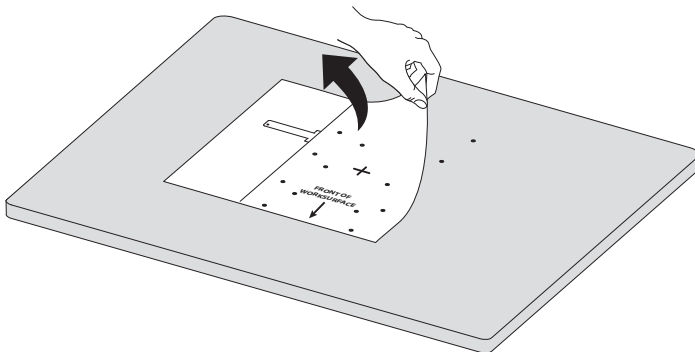

Set-up Steps

5

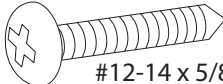
16x  #12-14 x 5/8"

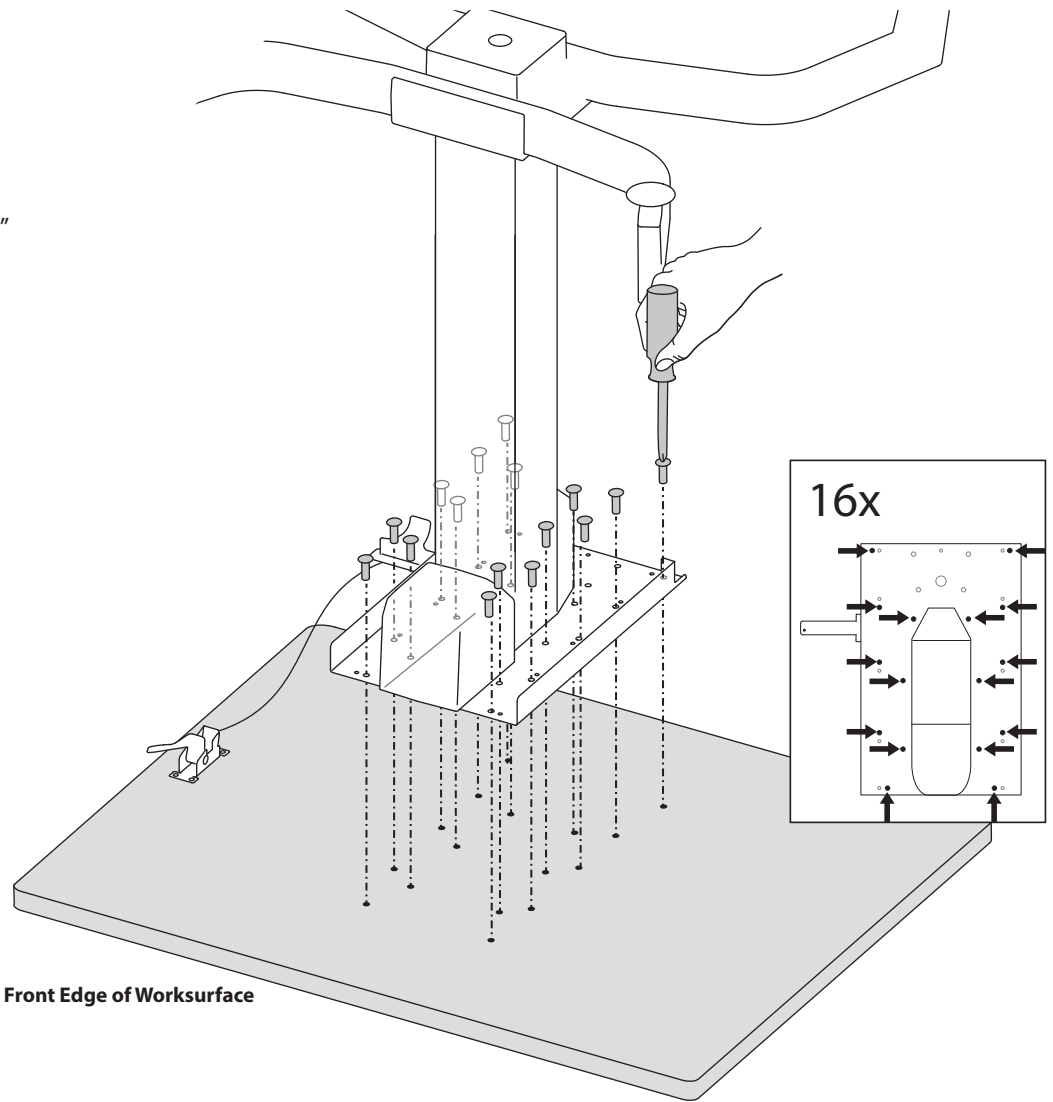

Front Edge of Worksurface

6

1x  M2.9 x 7mm

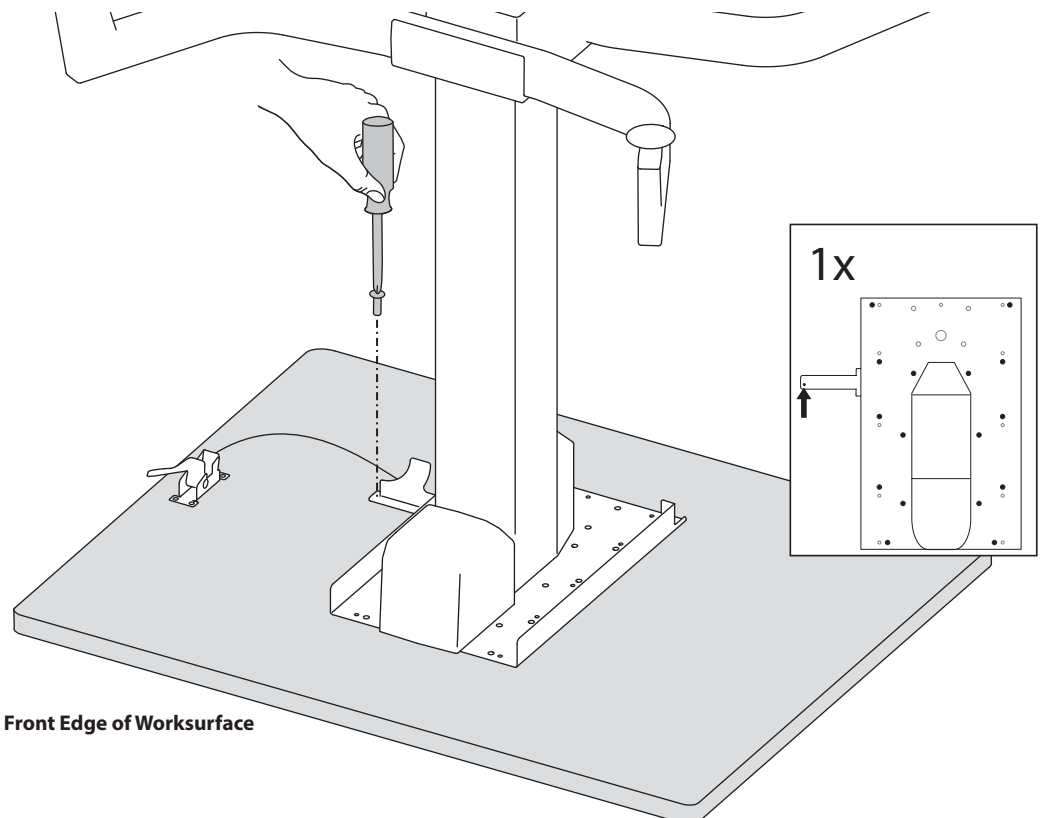

Front Edge of Worksurface

Set-up Steps

7 a Place the Brake Handle on the work surface at desired location. For easy access, line up the brake handle flush with the front edge of the worksurface.

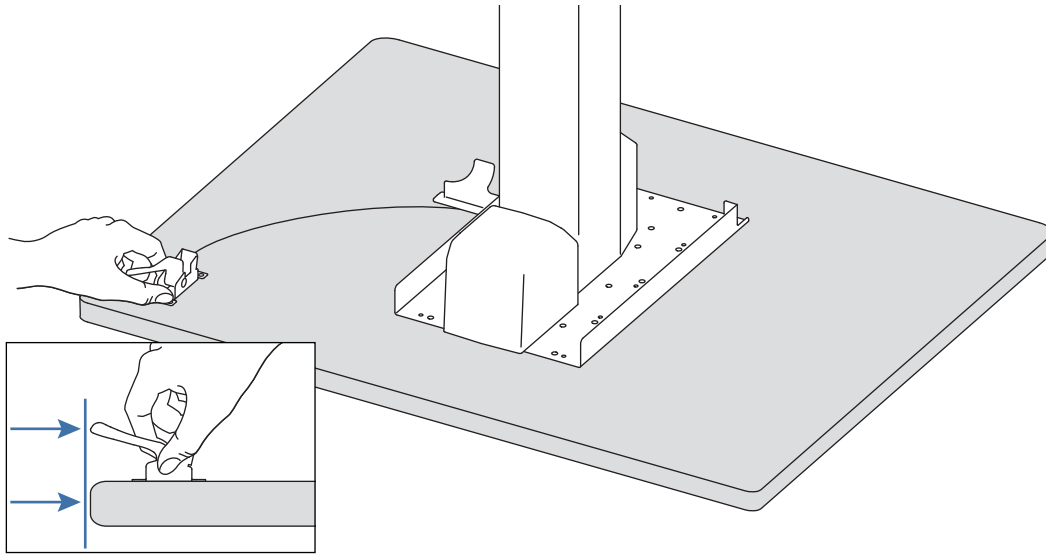

b Mark holes to drill.

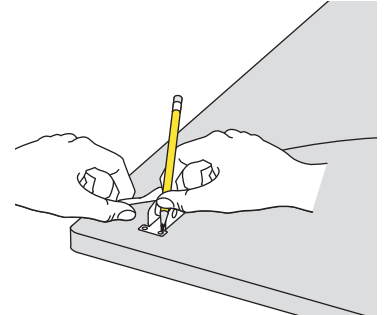

8 a Drill holes into bottom of work surface 5/16" (8 mm) deep. TIP: To ensure proper depth, place a piece of tape on the drill bit 5/16" (8 mm) from the tip.

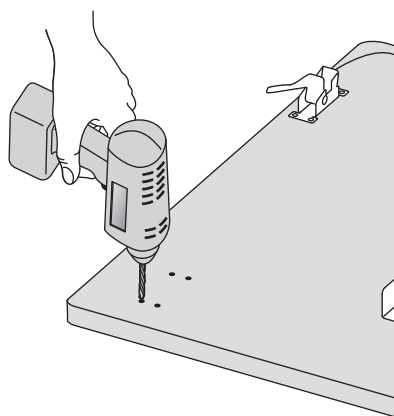
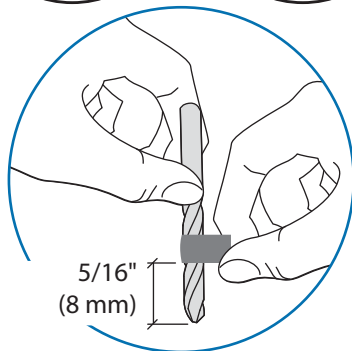
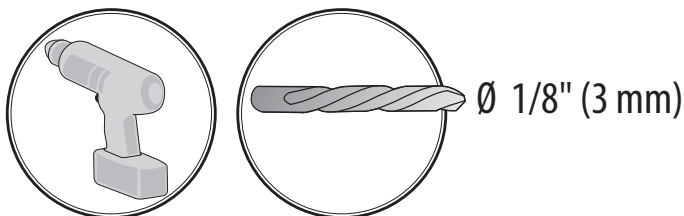

b Attach Brake Handle.

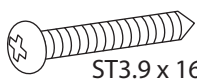
4x  ST3.9 x 16mm

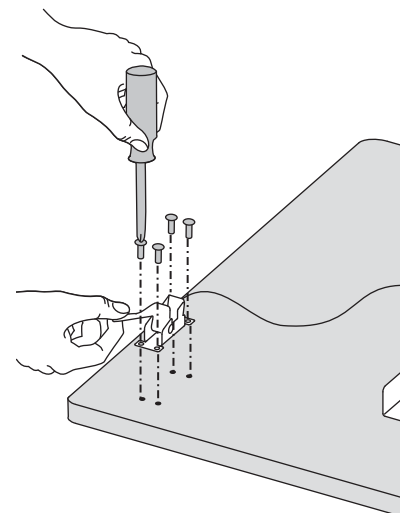

Set-up Steps

9

a

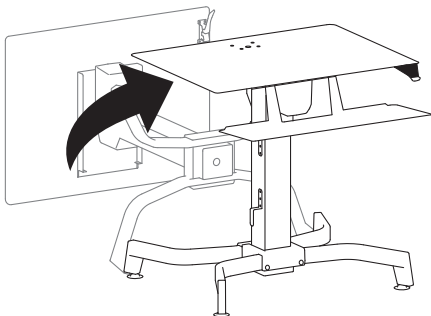

b

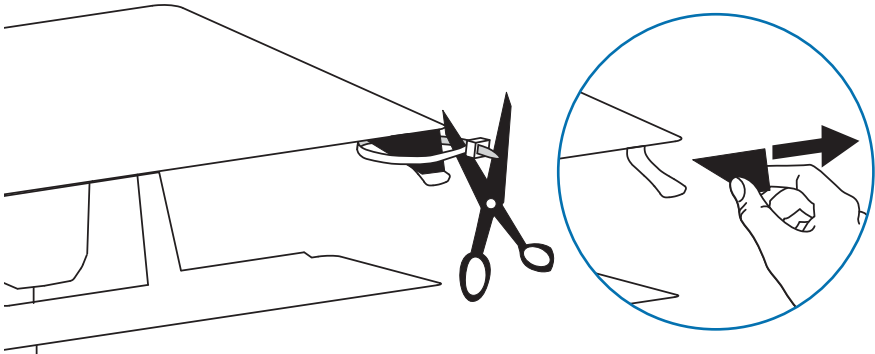

10

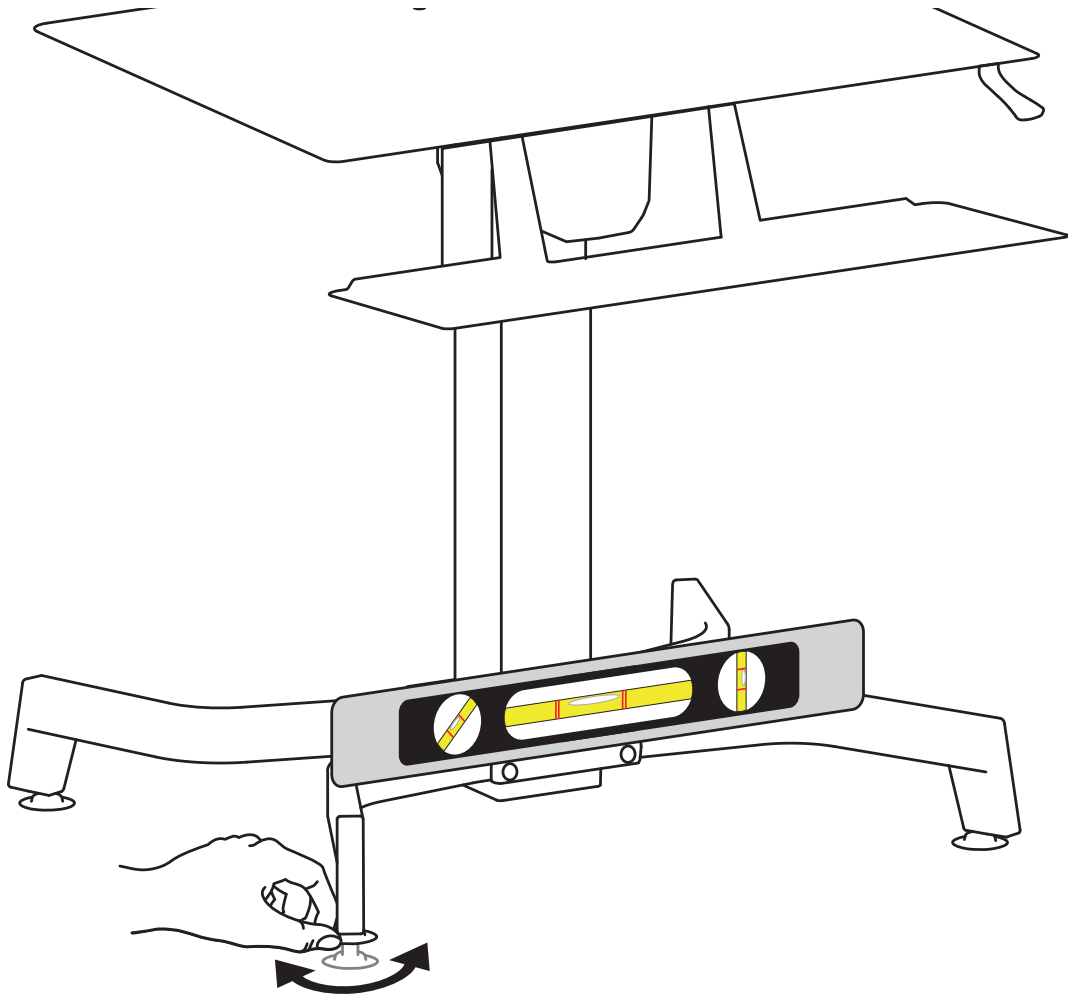

Set-up Steps

11

a Remove the stop screw to allow the worksurface to raise and lower before installing equipment.

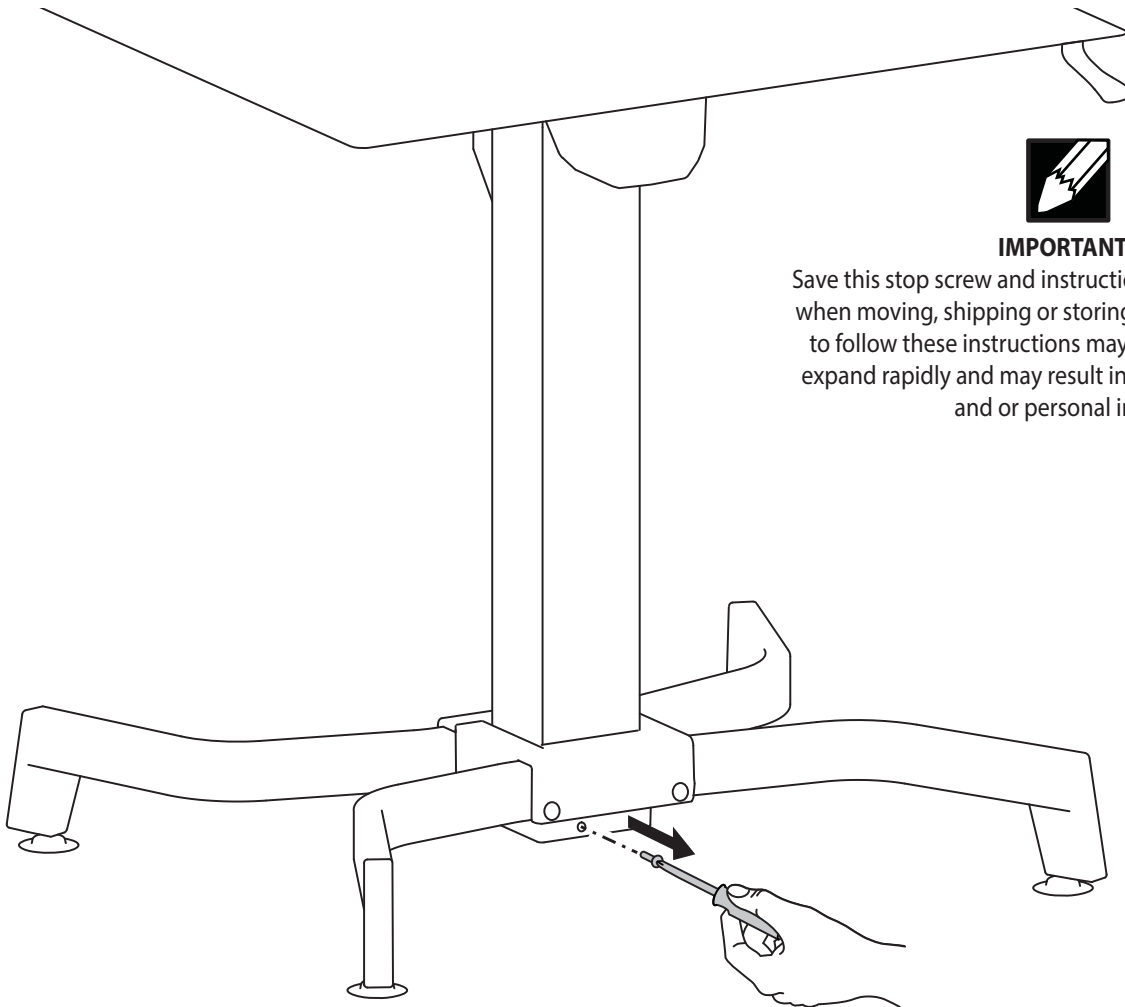
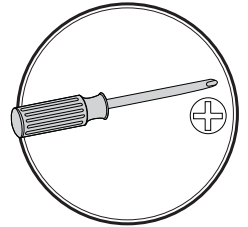

IMPORTANT!

Save this stop screw and instructions. Install stop screw when moving, shipping or storing this product. Failure to follow these instructions may cause lift engine to expand rapidly and may result in equipment damage and or personal injury.

b After you remove the stop screw, release the hand brake and move the worksurface up to highest level.

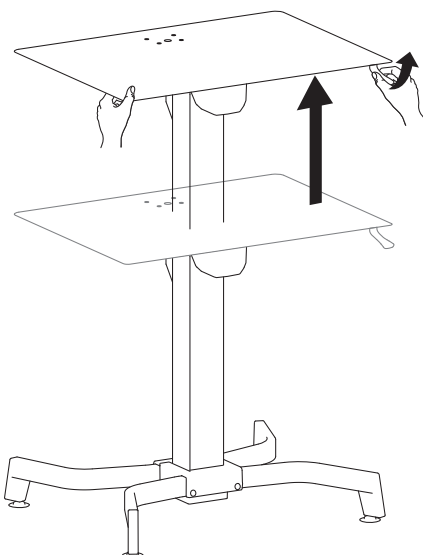

c After worksurface is raised to it's highest level, Install all equipment.



CAUTION! Make sure you leave 20" (508mm) of slack in all equipment cables to allow the worksurface to raise up it's full 20" (508mm). Failure to allow enough slack in equipment cables may cause cables to get pulled, equipment to fall off desk and may result in product damage and or personal injury.

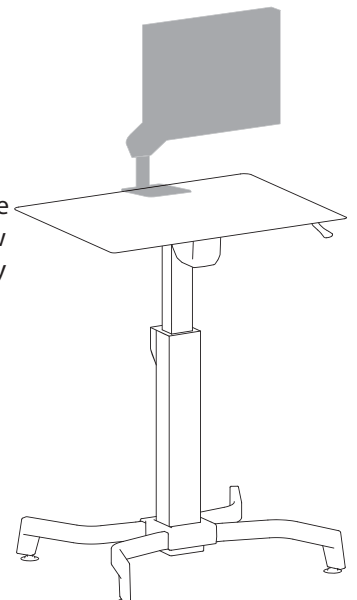

12 Adjustment Step

Important! You will need to adjust this product after installation is complete. Make sure all your equipment is properly installed on the product before attempting adjustments. This product should move smoothly and easily through the full range of motion and stay where you set it. If movements are too easy or difficult or if product does not stay in desired positions, follow the adjustment instructions to create smooth and easy movements. Depending on your product and the adjustment, it may take many turns to notice a difference. Any time equipment is added or removed from this product, resulting in a change in the weight of the mounted load, you should repeat these adjustment steps to ensure safe and optimum operation.

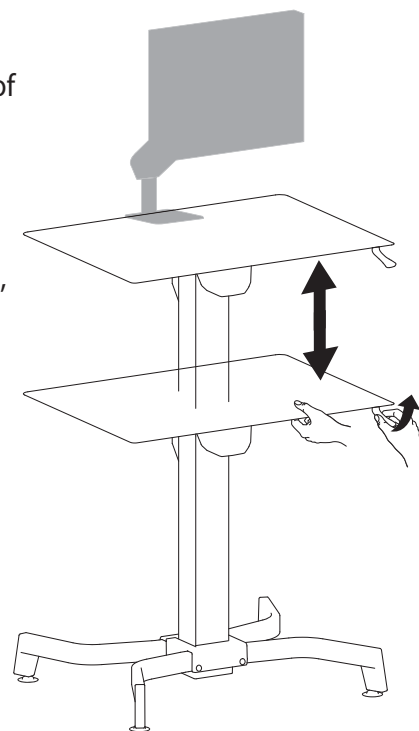

WARNING! DO NOT tip desk over to adjust. Only perform adjustment while desk is upright. Failure to follow these instructions may cause the lift engine to expand rapidly and may result in equipment damage and or personal injury.

!WARNING
IMPACT HAZARD

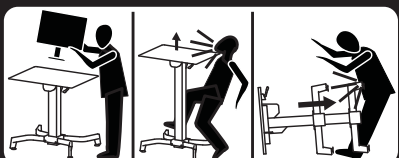

Minimize Lift Strength BEFORE:

- Removing Mounted Equipment
- Shipping the Cart
- Storing the Cart

Install Stop Screw BEFORE:

- Shipping the Cart
- Storing the Cart

To Minimize Lift Strength and Install Stop Screw:

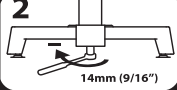
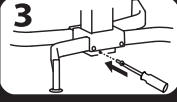
1. With cart upright, lower worksurface to lowest position. 
2. Turn adjustment nut at bottom of riser counter-clockwise until it stops (Adjustment may require 40-60 revolutions). 
3. Install Stop Screw. Follow Installation Instructions provided with Cart. 

Failure to heed this warning may result in serious personal injury or property damage!

Cart Must Remain Upright whenever Stop Screw is not installed. Tipping the cart on its side without Stop Screw installed may cause the work surface to disengage and cause serious personal injury and property damage.



For More information and instructions refer to product guide at www.ergotron.com or contact Ergotron Customer Care at 1-800-888-8458. 827-178-00

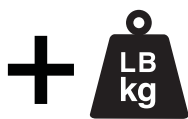

Increase Lift Strength

If the mounted weight is too heavy or this product does not stay up when raised, then you'll need to increase Lift Strength:



Decrease Lift Strength

If the mounted weight is too light or this product does not stay down when lowered, then you'll need to decrease Lift Strength:

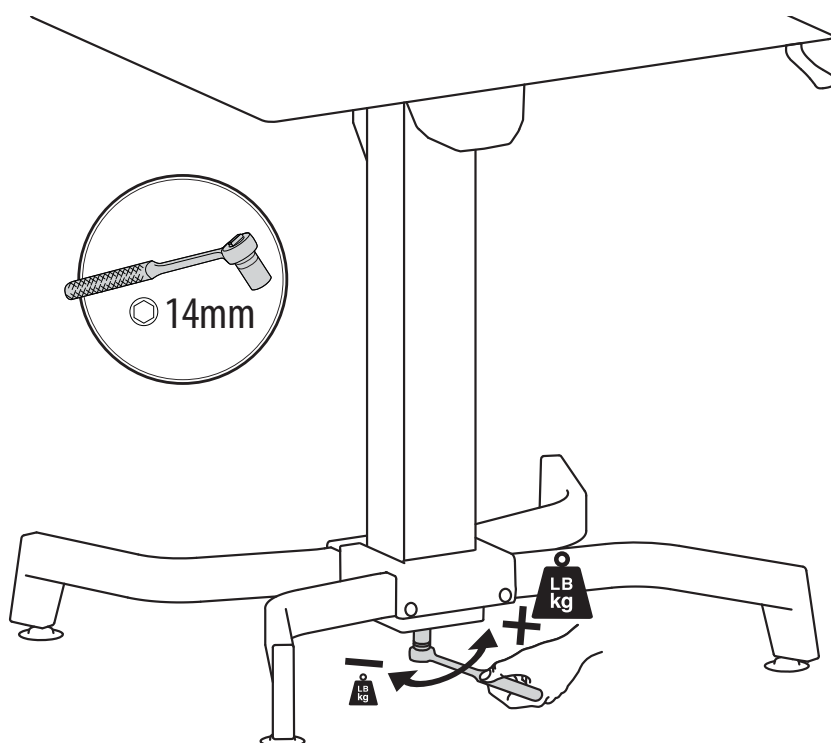

APPENDIX A - Minimize Lift Strength



WARNING. Before removing mounted equipment (monitor, arm, stand CPU, etc.), from desk, or to prepare for shipping or storing the desk it is extremely important to minimize the lift strength. Failure to install these instructions may cause lift engine to expand rapidly and may result in equipment damage and or personal injury.

1. Release the hand brake and move the worksurface up to highest level.
2. To minimize lift strength, turn adjustment bolt counter clockwise using a 14mm socket. Keep adjusting until the wrench stops turning.
3. Once at minimum lift strength it is ok to remove mounted equipment.

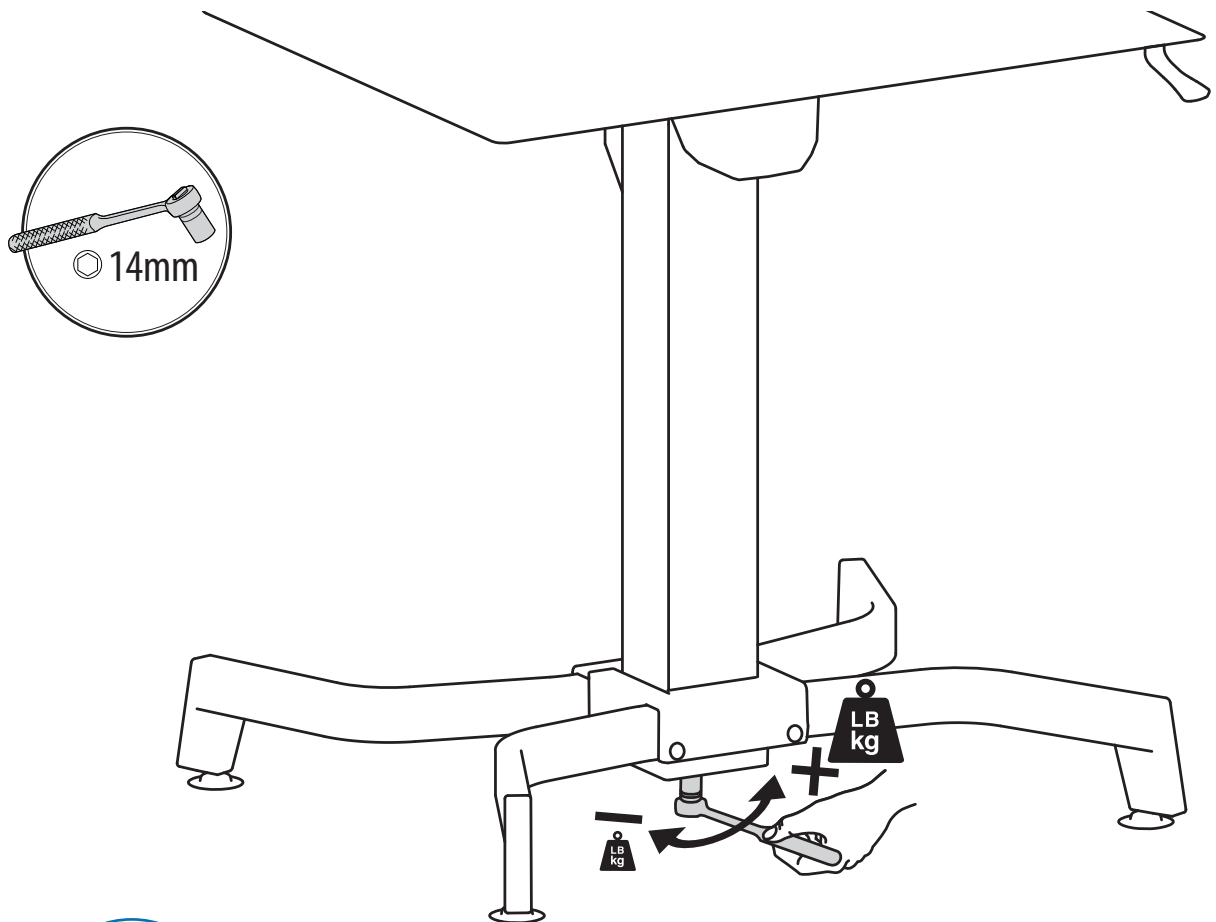

WARNING! DO NOT tip desk over to adjust. Only perform adjustment while desk is upright. Failure to follow these instructions may cause the lift engine to expand rapidly and may result in equipment damage and or personal injury.

APPENDIX B - Inserting Stop Screw



WARNING. Before shipping or storing the desk, or in cases where the desk is placed on its back or side*, it is extremely important that the stop screw be re-inserted. Failure to follow these instructions may cause lift engine to expand rapidly and may result in equipment damage and or personal injury.

1. Follow instructions in Appendix A to minimize lift strength.
2. Push the desk down past its lowest position.
3. While holding desk down, insert stop screw at the bottom of leg.
4. Once the stop screw has been installed the desk can be shipped or stored.

* Placing the desk on its back or side is not recommended.

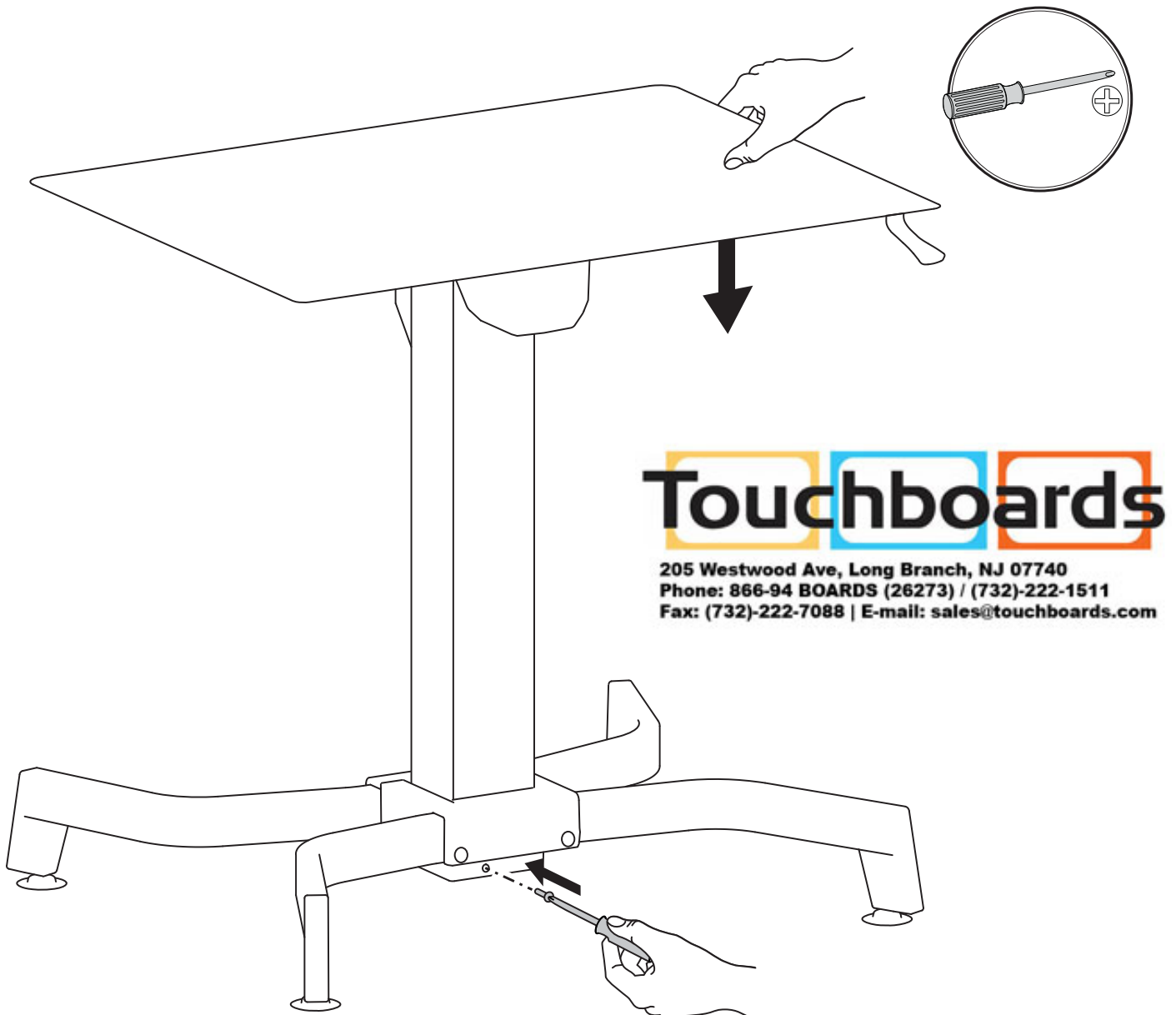

13

Set Your Workstation to Work For YOU!

Configure su estación de trabajo para que trabaje para USTED.

Ajustez votre station de travail en fonction de VOS besoins!

Richten Sie Ihren Arbeitsplatz so ein, dass er für SIE arbeitet!

Stel uw workstation zo in dat het voor U werkt!

Approntare la stazione di lavoro nella posizione ergonomica ottimale.

一人ひとりにピッタリのワークステーション!

按照您自身的需要设置工作站!

Learn more about ergonomic computer use at:

Más información sobre el uso ergonómico de ordenadores:

Apprenez-en plus sur l'utilisation ergonomique d'un ordinateur sur :

Weitere Informationen zur ergonomischen Computernutzung finden Sie unter:

Leer meer over ergonomisch computergebruik op:

Per ulteriori informazioni sull'uso ergonomico del computer:

人間工学的なコンピュータの使用法については次のサイトを参照してください

想进一步了解以符合人体工程学的方式使用计算机的知识, 请访问:

www.computingcomfort.org

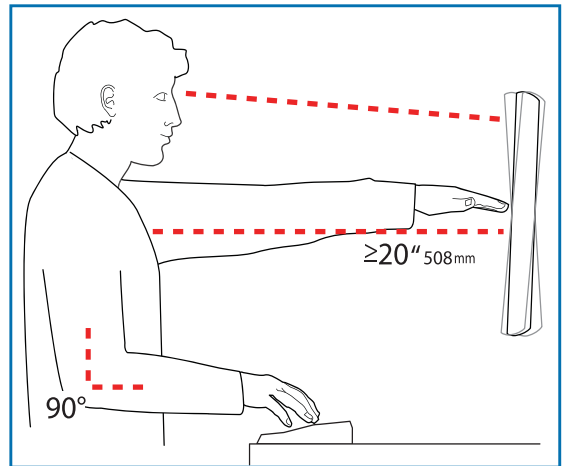

To Reduce Fatigue

Breathe - Breathe deeply through your nose.

Blink - Blink often to avoid dry eyes.

Break • 2 to 3 minutes every 20 minutes

• 15 to 20 minutes every 2 hours.

Para reducir la fatiga

Respirar - Respire hondo por la nariz.

Parpadear - Parpadee a menudo para que no se sequen los ojos.

Descansar • 2 o 3 minutos cada 20 minutos

• 15 o 20 minutos cada 2 horas.

Pour réduire la fatigue

Respirez - Respirez profondément par votre nez.

Clignez des yeux - Clignez souvent des yeux pour ne pas avoir les yeux secs.

Faites des pauses • 2 à 3 minutes toutes les 20 minutes

• 15 à 20 minutes toutes les 2 heures.

Vermeiden von Ermüdungserscheinungen

Atmen - Atmen Sie tief durch die Nase ein und aus.

Blinzeln - Blinzeln Sie so oft wie möglich, um trockene Augen zu vermeiden.

Pausen • Machen Sie alle 20 Minuten eine Pause von 2-3 Minuten

• Machen Sie alle 2 Stunden eine Pause von 15-20 Minuten.

Om vermoeidheid te verminderen

Ademen - Adem diep door uw neus in en uit.

Knippen - Knipper regelmatig om droge ogen te vermijden.

Pauses nemen • 2 tot 3 minuten elke 20 minuten

• 15 tot 20 minuten elke 2 uur.

Per ridurre l'affaticamento

Posizione - Respirare profondamente dal naso.

Battito delle palpebre - Battere spesso le palpebre per evitare che gli occhi si asciughino.

Pause • Fare una pausa di 2 - 3 minuti ogni 20 minuti

• Fare una pausa di 15 - 20 minuti ogni 2 ore.

Height Position top of screen slightly below eye level.

Position keyboard at about elbow height with wrists flat.

Distance Position screen an arm's length from face—at least 20" (508mm).

Position keyboard close enough to create a 90° angle in elbow.

Angle Tilt screen to eliminate glare.

Tilt the keyboard back 10° so that your wrists remain flat.

Altura Coloque el borde superior de la pantalla ligeramente por debajo de la altura de sus ojos.

Coloque el teclado aproximadamente a la altura de los codos con las muñecas planas.

Distancia Coloque la pantalla a una distancia de un brazo desde la cara, esto es, unos 50 cm (20 pulgadas).

Coloque el teclado lo suficientemente cerca para que el codo forme un ángulo de 90°.

Ángulo Incline la pantalla para eliminar los reflejos.

Incline el teclado 10° hacia atrás para que las muñecas sigan en posición plana.

Hauteur Positionnez l'écran du haut légèrement en dessous du niveau du regard.

Positionnez le clavier à peu près à la même hauteur que vos coudes, pour que vos poignets soient à plat.

Distance Positionnez l'écran à un bras de distance de votre visage, à au moins 508 mm (20 pouces).

Positionnez le clavier assez près pour que vos coudes forment un angle de 90°.

Angle Inclinez l'écran pour ne pas être ébloui.

Inclinez le clavier vers l'arrière de 10° pour que vos poignets soient à plat.

Höhe Positionieren Sie die obere Kante des Bildschirms knapp unter Augenhöhe.

Positionieren Sie die Tastatur bei flach aufgelegten Handgelenken auf Ellenbogenhöhe.

Abstand Positionieren Sie den Bildschirm mindestens eine Armlänge (50 cm) von Ihrem Gesicht entfernt.

Positionieren Sie die Tastatur nahe genug, um einen Ellenbogenwinkel von 90° zu ermöglichen.

Winkel Neigen Sie den Bildschirm so, dass ein Spiegeleffekt vermieden wird.

Neigen Sie die Tastatur um 10° nach hinten, sodass Ihre Handgelenke flach aufliegen.

Hoogte Zet de bovenkant van het scherm iets boven ooghoogte.

Plaats het toetsenbord op ongeveer ellebooghoogte met de polsen plat.

Afstand Plaats het scherm op een armlengte van uw gezicht — op ten minste 508 mm (20 in).

Zet uw toetsenbord zo dichtbij dat u een hoek van 90° in de ellebogen hebt.

Hoek Kantel het scherm om weerspiegeling te elimineren.

Kantel het toetsenbord 10° naar achteren, zodat uw polsen plat blijven liggen.

Altezza Posizionare la parte superiore dello schermo leggermente sotto il livello degli occhi.

Posizionare la tastiera circa all'altezza dei gomiti, in modo che i polsi siano piatti.

Distanza Posizionare lo schermo a un braccio di distanza dal viso, almeno a 20" (508 mm) di distanza.

Posizionare la tastiera affinché sia abbastanza vicina da costringere i gomiti a un angolo di 90°.

Angolazione Inclinare lo schermo in modo da eliminare i riflessi.

Inclinare la tastiera indietro di 10° in modo che i polsi rimangano piatti.

高さ スクリーンの上端が目よりわずかに下に来るようにします。

キーボードが、手首を水平に伸ばした状態でひじとほぼ同じ高さに来るようにします。

距離 スクリーンを顔から腕の長さ分(少なくとも508mm)離します。

ひじが直角になる位置にキーボードを置きます。

角度 反射光をなくすようにスクリーンの角度を調整します。

キーボードを後方に 10° 傾けて、手首が水平になるようにします。

疲れを軽減する方法

呼吸 - 鼻から深く呼吸します。

まばたき - 目の乾燥を防ぐために頻繁にまばたきしてください。

休憩 • 20分ごとに2~3分

• 2時間ごとに15~20分

高度 屏幕顶端的位置要稍低于视线高度。

将键盘放置在大约肘部的高度并且手腕要能放平。

距离 将屏幕摆放在距离面部一臂长的位置——至少 508mm (20")。

键盘的位置要够近, 以使肘部形成直角。

角度 倾斜屏幕以消除眩光。

将键盘向后倾斜 10 度, 使手腕能保持放平。

为了减轻疲劳

呼吸 - 通过鼻子深呼吸。

眨眼 - 经常眨眼可避免眼睛干涩。

休息 • 每隔 20 分钟休息 2 至 3 分钟

• 每隔 2 小时休息 15 至 20 分钟。



© 2013 Ergotron, Inc.
All rights reserved.

While Ergotron, Inc. makes every effort to provide accurate and complete information on the installation and use of its products, it will not be held liable for any editorial errors or omissions (including those made in the process of translation from English to another language), or for incidental, special or consequential damages of any nature resulting from furnishing this instruction and performance of equipment in connection with this instruction. Ergotron, Inc. reserves the right to make changes in the product design and/or product documentation without notification to its users. For the most current product information, or to know if this document is available in languages other than those herein, please contact Ergotron. No part of this publication may be reproduced, stored in a retrieval system, or transmitted in any form or by any means, electronic, mechanical, photocopying, recording or otherwise without the prior written consent of Ergotron, Inc., 1181 Trapp Road, Eagan, Minnesota, 55121, USA. Patents Pending and Patented U.S. & Foreign. Ergotron is a registered trademark of Ergotron, Inc.

Americas Sales and Corporate Headquarters

St. Paul, MN USA
(800) 888-8458
+1-651-681-7600
www.ergotron.com
sales@ergotron.com

EMEA Sales

Amersfoort, The Netherlands
+31 33 45 45 600
www.ergotron.com
info.eu@ergotron.com

APAC Sales

Tokyo, Japan
www.ergotron.com
apaccustomerservice@ergotron.com

Worldwide OEM Sales

www.ergotron.com
info.oem@ergotron.com