

For the latest User Installation Guide please visit: www.ergotron.com



User's Guide - English
Guía del usuario - Español
Manuel de l'utilisateur - Français
Gebruikersgids - Deutsch
Benutzerhandbuch - Nederlands
Guida per l'utente - Italiano
Användarhandbok - svenska
ユーザーガイド : 日本語
用户指南 : 汉语

 Includes
Constant Force™
Technology



www.ergotron.com

USA 1-800-888-8458

Europe +31 (0)33-45 45 600

China 400-120-3051

Safety



WARNING

IMPACT HAZARD

Moving Parts Can Crush & Cut

Do not tip the cart over on side or upside down. Cart must remain upright at all times. Tipping cart on side or upside down may cause unintended motion of the riser. Failure to heed this warning may result in serious personal injury or property damage!

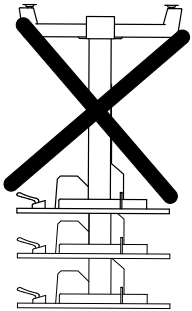
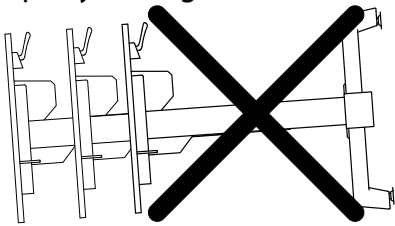

For more information on safe set-up and use of this product, refer to use manual at www.ergotron.com or contact Ergotron Customer Care at 1-800-888-8458.

827-515-00

ENGLISH

Components

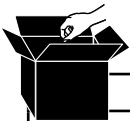

	A	B	C
1	1x 	1x 	1x

1 Insert riser into base.

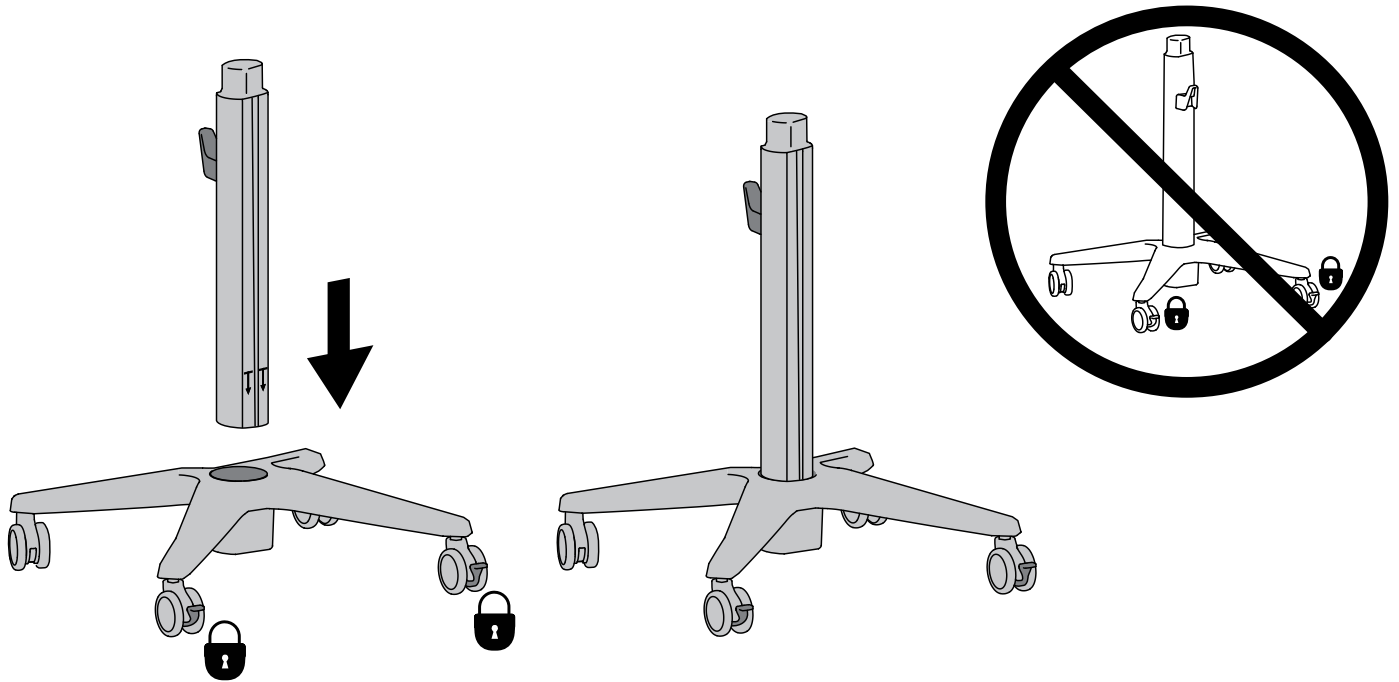

2 Remove cap.

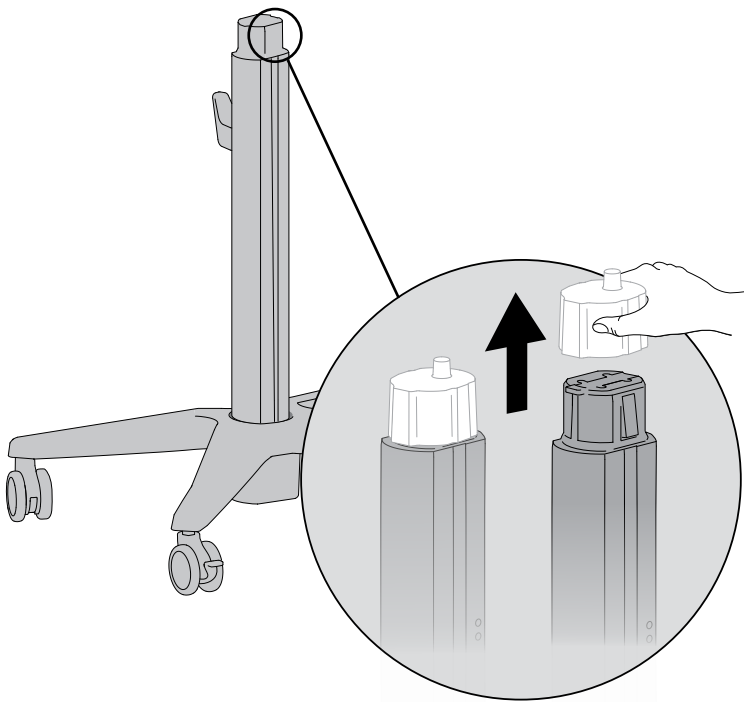

3 Attach work surface and press down.

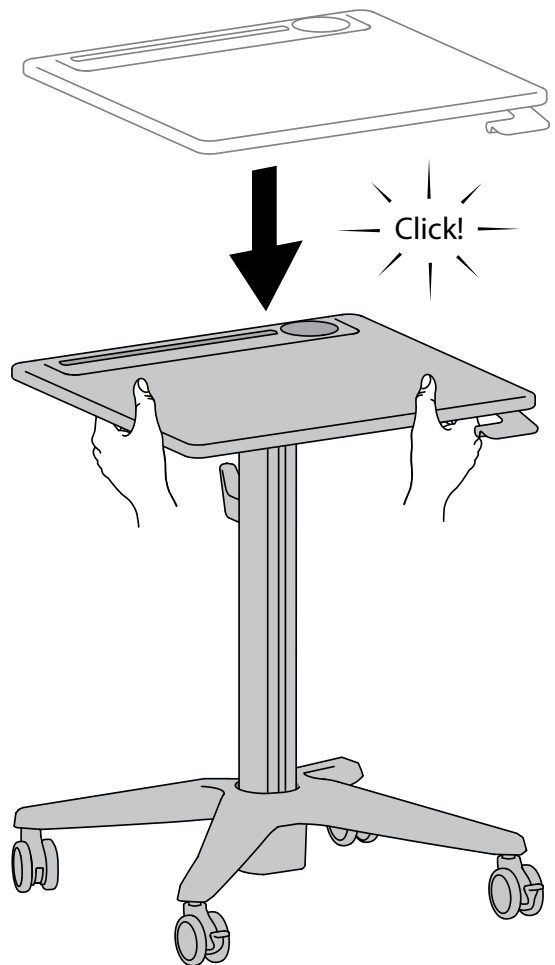

4

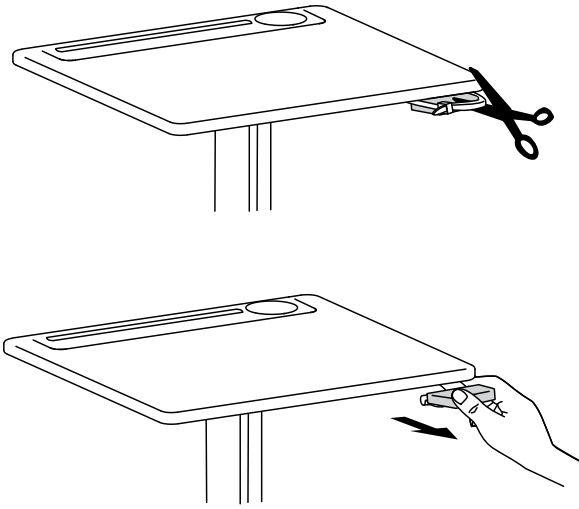

5

Lift brake release lever to raise and lower riser.

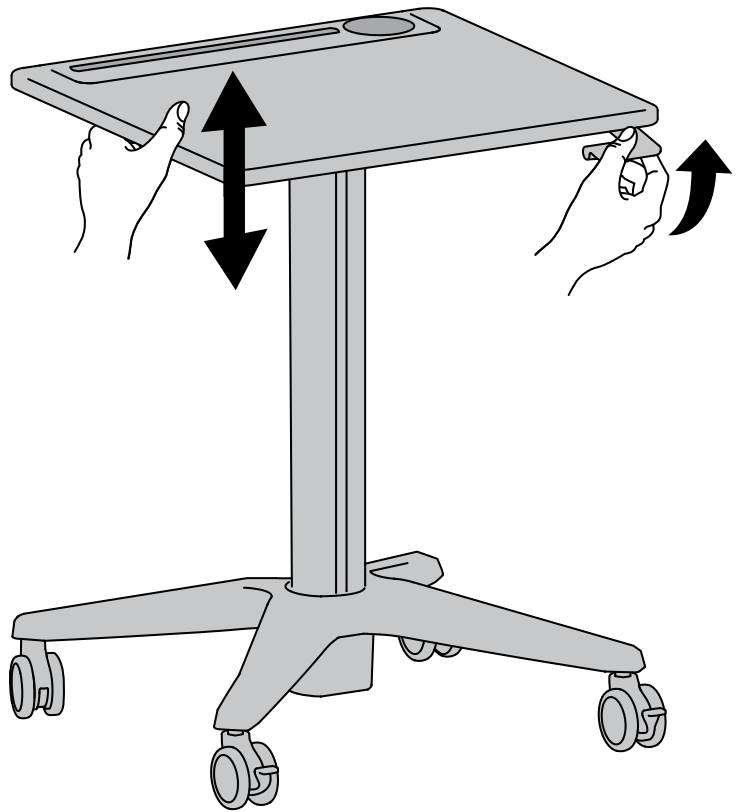

6

Loosen 2 screws to lift and lower hook.

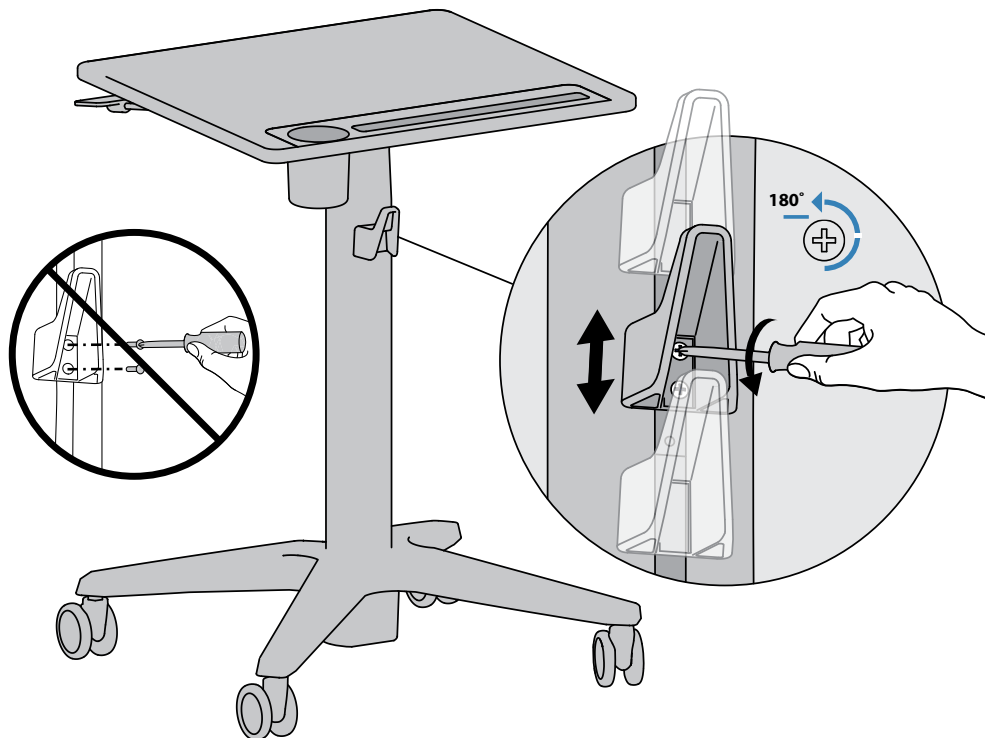

How to Disassemble



To remove worksurface, push tab with a tool while removing.

NOTE: Requires two people.

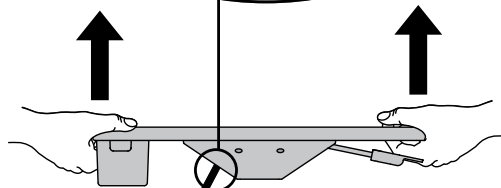
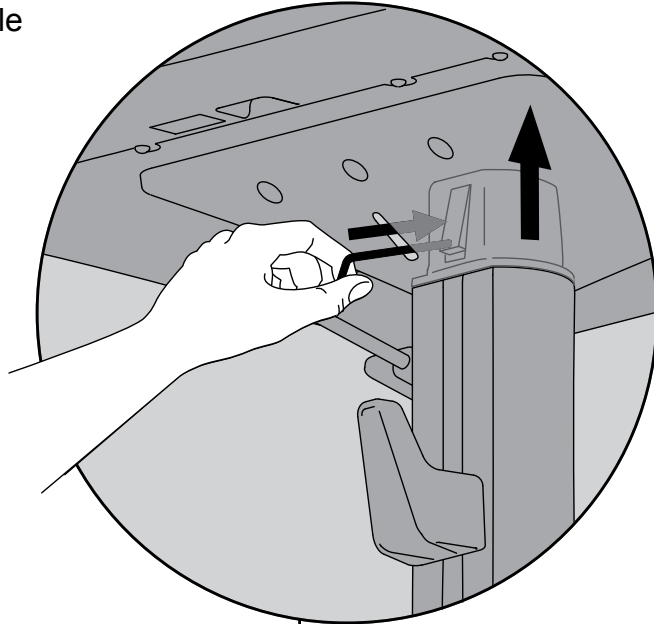
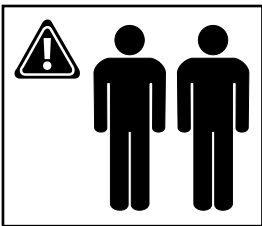

Attach cap.

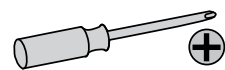
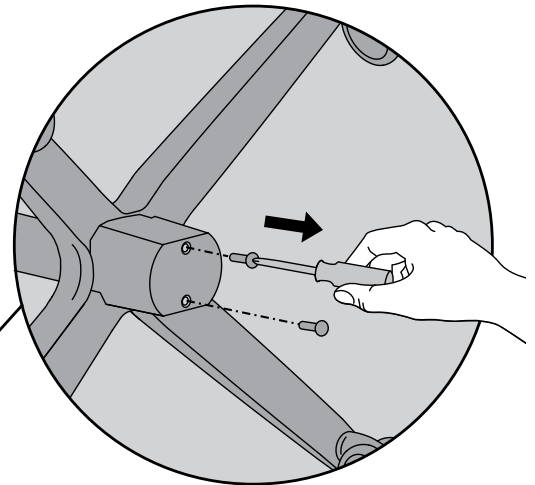
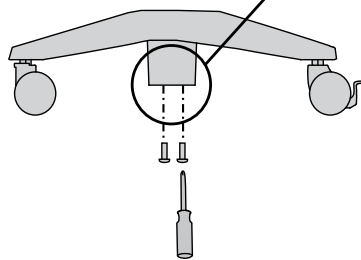
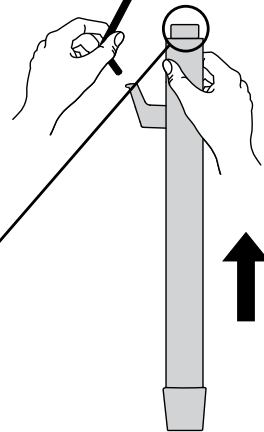
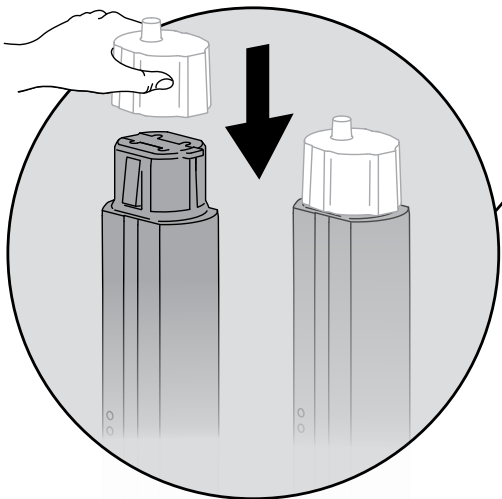

Set Your Workstation to Work For YOU!

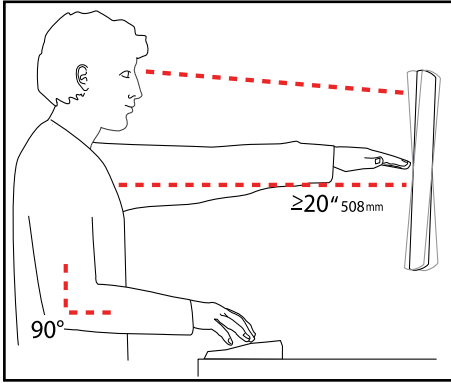

Learn more about ergonomic computer use at:
www.computingcomfort.org

- Height** Position top of screen slightly below eye level.
Position keyboard at about elbow height with wrists flat.
- Distance** Position screen an arm's length from face—at least 20" (508mm).
Position keyboard close enough to create a 90° angle in elbow.
- Angle** Tilt screen to eliminate glare.
Tilt the keyboard back 10° so that your wrists remain flat.

To Reduce Fatigue
Breathe - Breathe deeply through your nose.
Blink - Blink often to avoid dry eyes.
Break • 2 to 3 minutes every 20 minutes
• 15 to 20 minutes every 2 hours.

For service and warranty visit www.ergotron.com/warranty

For local customer care phone numbers visit: <http://contact.ergotron.com>



NOTE: When contacting customer service, reference the serial number.

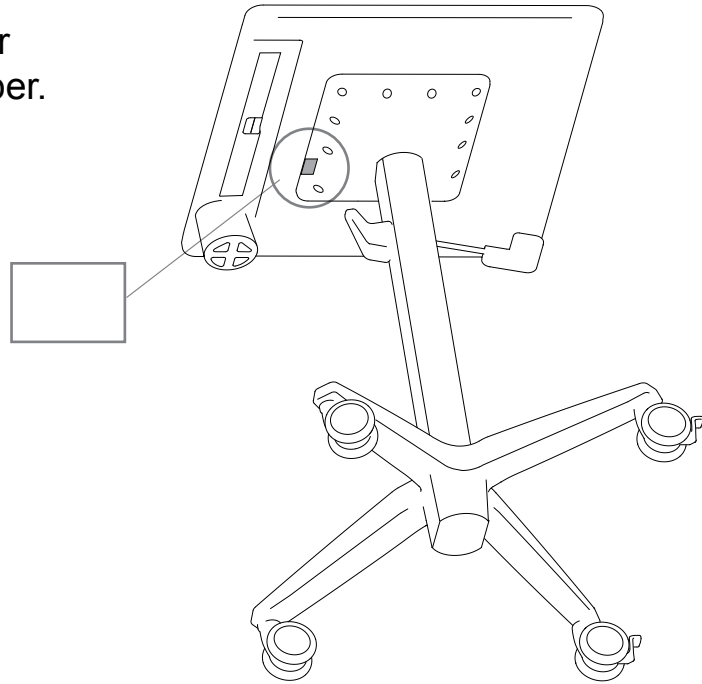

Americas Sales and Corporate Headquarters

1181 Trapp Rd.
St. Paul, MN USA
(800) 888-8458
+1-651-681-7600
www.ergotron.com
sales@ergotron.com

APAC Sales

Tokyo, Japan
www.ergotron.com
apaccustomerservice@ergotron.com

EMEA Sales

Amersfoort, The Netherlands
+31 33 45 45 600
www.ergotron.com
info.eu@ergotron.com

Worldwide OEM Sales

www.ergotron.com
info.oem@ergotron.com

ERGOTRON®

While Ergotron, Inc. makes every effort to provide accurate and complete information on the installation and use of its products, it will not be held liable for any editorial errors or omissions (including those made in the process of translation from English to another language), or for incidental, special or consequential damages of any nature resulting from furnishing this instruction and performance of equipment in connection with this instruction. Ergotron, Inc. reserves the right to make changes in the product design and/or product documentation without notification to its users. For the most current product information, or to know if this document is available in languages other than those herein, please contact Ergotron. No part of this publication may be reproduced, stored in a retrieval system, or transmitted in any form or by any means, electronic, mechanical, photocopying, recording or otherwise without the prior written consent of Ergotron, Inc., 1181 Trapp Road, Eagan, Minnesota, 55121, USA. Patents Pending and Patented U.S. & Foreign. Ergotron is a registered trademark of Ergotron, Inc.