

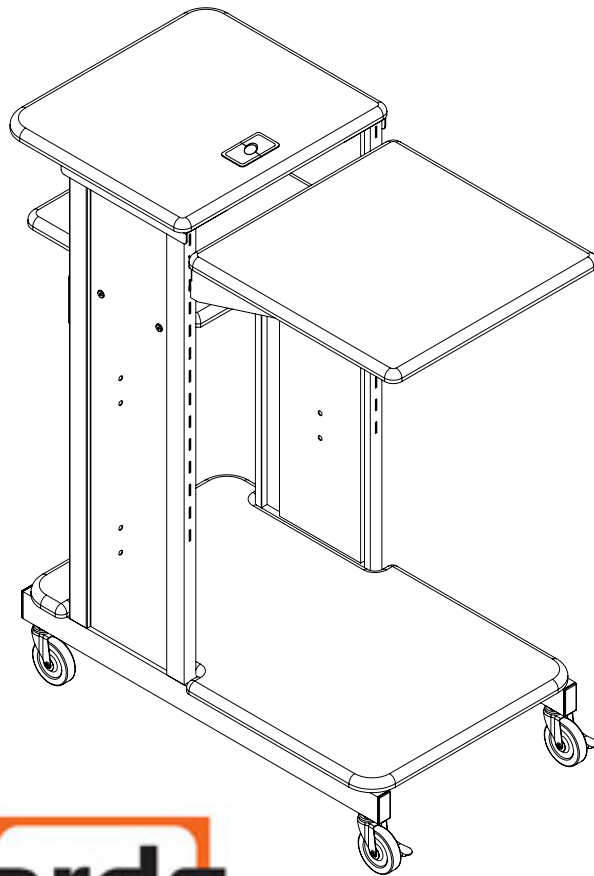

**BLT-27521**











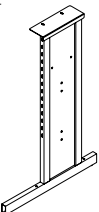
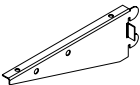
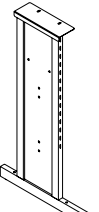
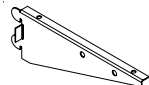
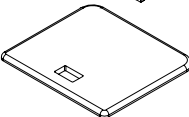

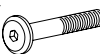

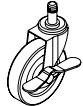

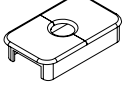

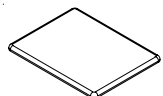
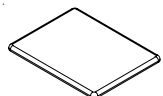
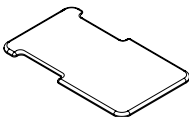
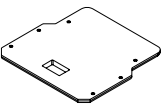
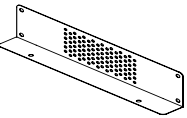
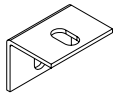

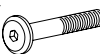

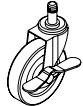

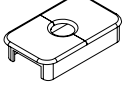
# Xtra Long Presentation Cart

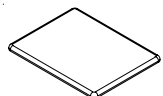
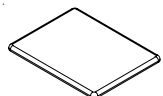
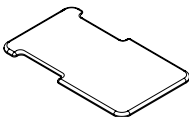
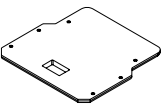
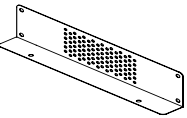
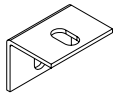

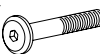
205 Westwood Ave, Long Branch, NJ 07740  
Phone: 866-94 BOARDS (26273) / (732)-222-1511  
Fax: (732)-222-7088 | E-mail: [sales@touchboards.com](mailto:sales@touchboards.com)

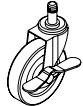
## Assembly Instructions

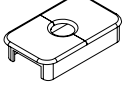
# Xtra Long Presentation Cart

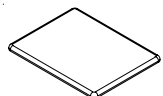
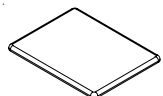
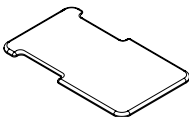
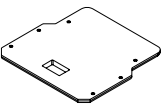
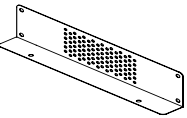
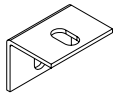
| Part | Drawing  | Description         | Qty   | Part  | Drawing   | Description         | Qty  |   |   |                    |       |   |  |                     |      |   |   |            |      |     |  |                   |      |     |  |           |      |   |  |                 |      |   |   |              |      |    |   |              |      |   |   |               |      |    |  |             |      |  |  |  |  |    |   |              |      |  |  |  |  |    |   |                 |      |  |  |  |  |    |   |               |      |  |  |  |  |
|------|--|---------------------|-------|---|---|---------------------|------|---|---|--------------------|-------|---|--|---------------------|------|---|---|------------|------|-----|--|-------------------|------|-----|--|-----------|------|---|--|-----------------|------|---|---|--------------|------|----|---|--------------|------|---|---|---------------|------|----|--|-------------|------|--|--|--|--|----|---|--------------|------|--|--|--|--|----|---|-----------------|------|--|--|--|--|----|---|---------------|------|--|--|--|--|
| P1   |     | Leg Assembly Right  | 1 EA  | P-9   |   | Right Shelf Bracket | 1 EA |   |   |                    |       |   |  |                     |      |   |   |            |      |     |  |                   |      |     |  |           |      |   |  |                 |      |   |   |              |      |    |   |              |      |   |   |               |      |    |  |             |      |  |  |  |  |    |   |              |      |  |  |  |  |    |   |                 |      |  |  |  |  |    |   |               |      |  |  |  |  |
| P2   |     | Leg Assembly Left   | 1 EA  | P-10  |   | Left Shelf Bracket  | 1 EA |   |   |                    |       |   |  |                     |      |   |   |            |      |     |  |                   |      |     |  |           |      |   |  |                 |      |   |   |              |      |    |   |              |      |   |   |               |      |    |  |             |      |  |  |  |  |    |   |              |      |  |  |  |  |    |   |                 |      |  |  |  |  |    |   |               |      |  |  |  |  |
| P3   |     | LCD Platform        | 1 EA  | <div style="text-align: center;"> <h3>Hardware List</h3> <table border="1"> <tbody> <tr> <td>A</td> <td></td> <td>9/16" Socket Screw</td> <td>22 EA</td> </tr> <tr> <td>B</td> <td></td> <td>2-1/2" Socket Screw</td> <td>6 EA</td> </tr> <tr> <td>C</td> <td></td> <td>Square Nut</td> <td>4 EA</td> </tr> <tr> <td>D-1</td> <td></td> <td>3" Locking Caster</td> <td>2 EA</td> </tr> <tr> <td>D-2</td> <td></td> <td>3" Caster</td> <td>2 EA</td> </tr> <tr> <td>E</td> <td></td> <td>Plastic Grommet</td> <td>2 EA</td> </tr> <tr> <td>F</td> <td></td> <td>Allen Wrench</td> <td>1 EA</td> </tr> <tr> <td>P4</td> <td></td> <td>Laptop Shelf</td> <td>1 EA</td> <td>G</td> <td></td> <td>Caster Wrench</td> <td>1 EA</td> </tr> <tr> <td>P5</td> <td></td> <td>Lower Shelf</td> <td>1 EA</td> <td colspan="4"></td> </tr> <tr> <td>P6</td> <td></td> <td>Middle Shelf</td> <td>1 EA</td> <td colspan="4"></td> </tr> <tr> <td>P7</td> <td></td> <td>Stability Panel</td> <td>1 EA</td> <td colspan="4"></td> </tr> <tr> <td>P8</td> <td></td> <td>Angle Bracket</td> <td>4 EA</td> <td colspan="4"></td> </tr> </tbody> </table> </div> <div data-bbox="134 1617 706 1659" data-label="Section-Header"> <h3>Missing Parts or UPS Damaged Parts</h3> </div> <div data-bbox="206 1656 634 1814" data-label="Text"> <p>For Your Convenience you can<br/>EMAIL us at<br/><b><a href="mailto:furniture@baltinc.com">furniture@baltinc.com</a></b><br/>24HOURS 7 DAYS A WEEK</p> </div> <div data-bbox="873 1688 1448 1764" data-label="Text"> <p><i>We recommend that you assemble this<br/>unit on a table.</i></p> </div> <div data-bbox="820 1768 1390 1806" data-label="Text"> <p>Tools required: Adjustable Crescent Wrench</p> </div> <div data-bbox="199 1866 1438 1965" data-label="Text"> <p>Do not use unless all screws are tight. At least every six months, check all screws to be sure they are tight. If parts are missing, broken, damaged, or worn, stop use of the product until repairs are made by your dealer using factory authorized parts.</p> </div> <div data-bbox="797 1997 824 2030" data-label="Page-Footer"> <p>2</p> </div> |   |                     |      | A |  | 9/16" Socket Screw | 22 EA | B |  | 2-1/2" Socket Screw | 6 EA | C |  | Square Nut | 4 EA | D-1 |  | 3" Locking Caster | 2 EA | D-2 |  | 3" Caster | 2 EA | E |  | Plastic Grommet | 2 EA | F |  | Allen Wrench | 1 EA | P4 |  | Laptop Shelf | 1 EA | G |  | Caster Wrench | 1 EA | P5 |  | Lower Shelf | 1 EA |  |  |  |  | P6 |  | Middle Shelf | 1 EA |  |  |  |  | P7 |  | Stability Panel | 1 EA |  |  |  |  | P8 |  | Angle Bracket | 4 EA |  |  |  |  |
| A    |     | 9/16" Socket Screw  | 22 EA |   |   |                     |      |   |   |                    |       |   |  |                     |      |   |   |            |      |     |  |                   |      |     |  |           |      |   |  |                 |      |   |   |              |      |    |   |              |      |   |   |               |      |    |  |             |      |  |  |  |  |    |   |              |      |  |  |  |  |    |   |                 |      |  |  |  |  |    |   |               |      |  |  |  |  |
| B    |    | 2-1/2" Socket Screw | 6 EA  |   |   |                     |      |   |   |                    |       |   |  |                     |      |   |   |            |      |     |  |                   |      |     |  |           |      |   |  |                 |      |   |   |              |      |    |   |              |      |   |   |               |      |    |  |             |      |  |  |  |  |    |   |              |      |  |  |  |  |    |   |                 |      |  |  |  |  |    |   |               |      |  |  |  |  |
| C    |     | Square Nut          | 4 EA  |   |   |                     |      |   |   |                    |       |   |  |                     |      |   |   |            |      |     |  |                   |      |     |  |           |      |   |  |                 |      |   |   |              |      |    |   |              |      |   |   |               |      |    |  |             |      |  |  |  |  |    |   |              |      |  |  |  |  |    |   |                 |      |  |  |  |  |    |   |               |      |  |  |  |  |
| D-1  |  | 3" Locking Caster   | 2 EA  |   |   |                     |      |   |   |                    |       |   |  |                     |      |   |   |            |      |     |  |                   |      |     |  |           |      |   |  |                 |      |   |   |              |      |    |   |              |      |   |   |               |      |    |  |             |      |  |  |  |  |    |   |              |      |  |  |  |  |    |   |                 |      |  |  |  |  |    |   |               |      |  |  |  |  |
| D-2  |  | 3" Caster           | 2 EA  |   |   |                     |      |   |   |                    |       |   |  |                     |      |   |   |            |      |     |  |                   |      |     |  |           |      |   |  |                 |      |   |   |              |      |    |   |              |      |   |   |               |      |    |  |             |      |  |  |  |  |    |   |              |      |  |  |  |  |    |   |                 |      |  |  |  |  |    |   |               |      |  |  |  |  |
| E    |  | Plastic Grommet     | 2 EA  |   |   |                     |      |   |   |                    |       |   |  |                     |      |   |   |            |      |     |  |                   |      |     |  |           |      |   |  |                 |      |   |   |              |      |    |   |              |      |   |   |               |      |    |  |             |      |  |  |  |  |    |   |              |      |  |  |  |  |    |   |                 |      |  |  |  |  |    |   |               |      |  |  |  |  |
| F    |   | Allen Wrench        | 1 EA  |   |   |                     |      |   |   |                    |       |   |  |                     |      |   |   |            |      |     |  |                   |      |     |  |           |      |   |  |                 |      |   |   |              |      |    |   |              |      |   |   |               |      |    |  |             |      |  |  |  |  |    |   |              |      |  |  |  |  |    |   |                 |      |  |  |  |  |    |   |               |      |  |  |  |  |
| P4   |     | Laptop Shelf        | 1 EA  | G   |  | Caster Wrench       | 1 EA |   |   |                    |       |   |  |                     |      |   |   |            |      |     |  |                   |      |     |  |           |      |   |  |                 |      |   |   |              |      |    |   |              |      |   |   |               |      |    |  |             |      |  |  |  |  |    |   |              |      |  |  |  |  |    |   |                 |      |  |  |  |  |    |   |               |      |  |  |  |  |
| P5   |    | Lower Shelf         | 1 EA  |   |   |                     |      |   |   |                    |       |   |  |                     |      |   |   |            |      |     |  |                   |      |     |  |           |      |   |  |                 |      |   |   |              |      |    |   |              |      |   |   |               |      |    |  |             |      |  |  |  |  |    |   |              |      |  |  |  |  |    |   |                 |      |  |  |  |  |    |   |               |      |  |  |  |  |
| P6   |   | Middle Shelf        | 1 EA  |   |   |                     |      |   |   |                    |       |   |  |                     |      |   |   |            |      |     |  |                   |      |     |  |           |      |   |  |                 |      |   |   |              |      |    |   |              |      |   |   |               |      |    |  |             |      |  |  |  |  |    |   |              |      |  |  |  |  |    |   |                 |      |  |  |  |  |    |   |               |      |  |  |  |  |
| P7   |   | Stability Panel     | 1 EA  |   |   |                     |      |   |   |                    |       |   |  |                     |      |   |   |            |      |     |  |                   |      |     |  |           |      |   |  |                 |      |   |   |              |      |    |   |              |      |   |   |               |      |    |  |             |      |  |  |  |  |    |   |              |      |  |  |  |  |    |   |                 |      |  |  |  |  |    |   |               |      |  |  |  |  |
| P8   |   | Angle Bracket       | 4 EA  |   |   |                     |      |   |   |                    |       |   |  |                     |      |   |   |            |      |     |  |                   |      |     |  |           |      |   |  |                 |      |   |   |              |      |    |   |              |      |   |   |               |      |    |  |             |      |  |  |  |  |    |   |              |      |  |  |  |  |    |   |                 |      |  |  |  |  |    |   |               |      |  |  |  |  |

# #27521 Assembly Diagram

**READ THROUGH INSTRUCTIONS FROM BEGINNING TO END BEFORE STARTING TO ASSEMBLE UNIT.**

- 1.) Identify and Separate all the Parts and Hardware.
- 2.) Place the LCD Platform (P-3) with the insert nuts facing up. Attach 1 Right Leg Assembly (P-1) and 1 Left Leg Assembly (P-2) using 4 each (A) screws.  
*(Finger tighten only)*

***Should you require assistance during assembly, please call our Customer Service Department Monday - Friday 8 a.m. - 5 p.m. Central Standard Time 1-800-749-2258***

- 3.) Attach Stability Panel (P-7) to Right & Left Leg Assemblies (P-1 & P-2) using 4 (A) Screws as shown in illustration #1.  
*(Finger tighten only)*

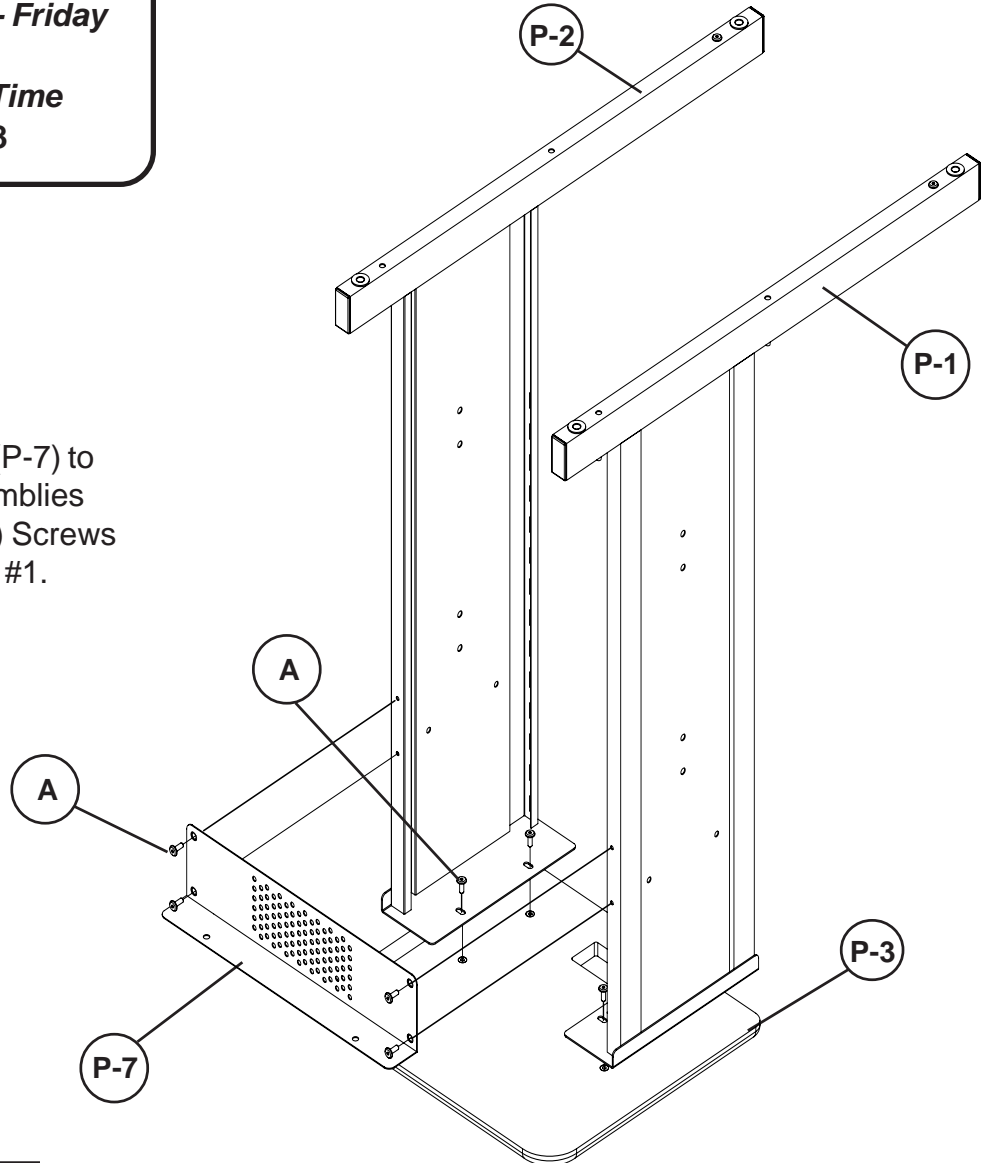

**Illustration # 1**

- 4.) Align 4 each Angle Brackets (P-8) with the edge of the Middle Shelf (P-6) and attach using 4 each (A) Screws as shown in illustration #2. (**Finger tighten only**)

Illustration # 2

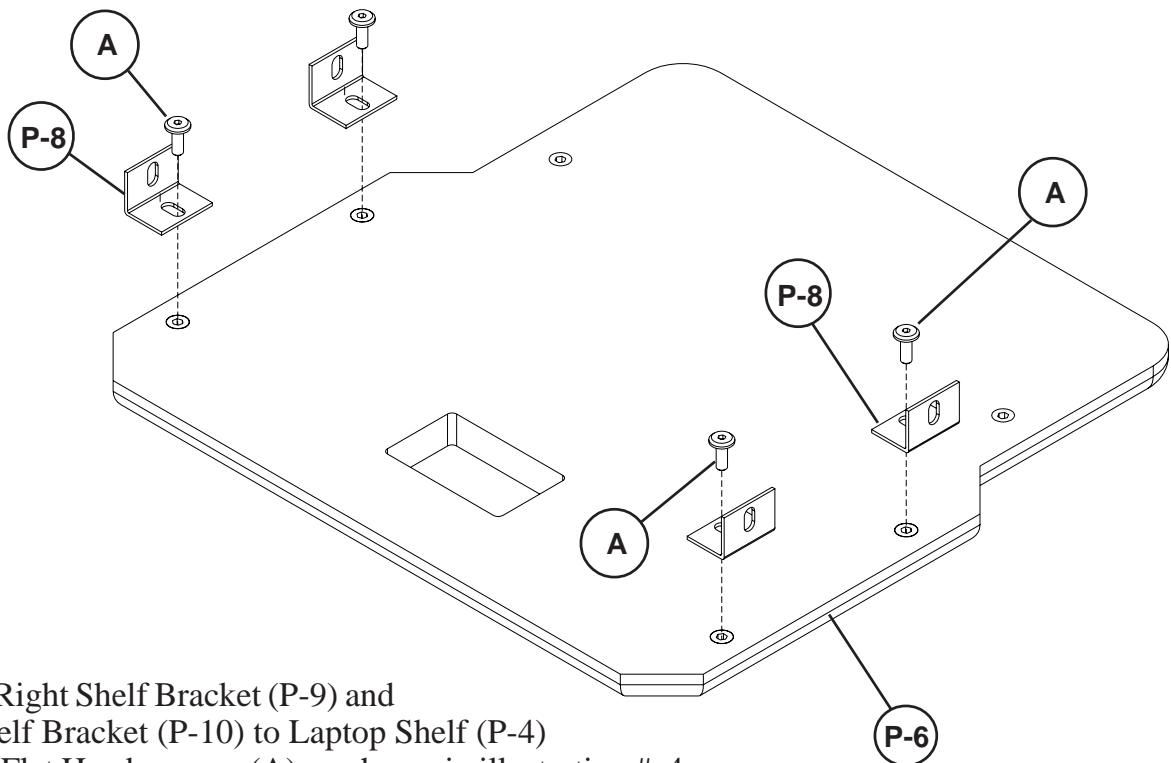

- 5.) Attach Right Shelf Bracket (P-9) and Left Shelf Bracket (P-10) to Laptop Shelf (P-4) using 4 Flat Head screws (A) as shown in illustration # 4. (**Finger tighten only**)

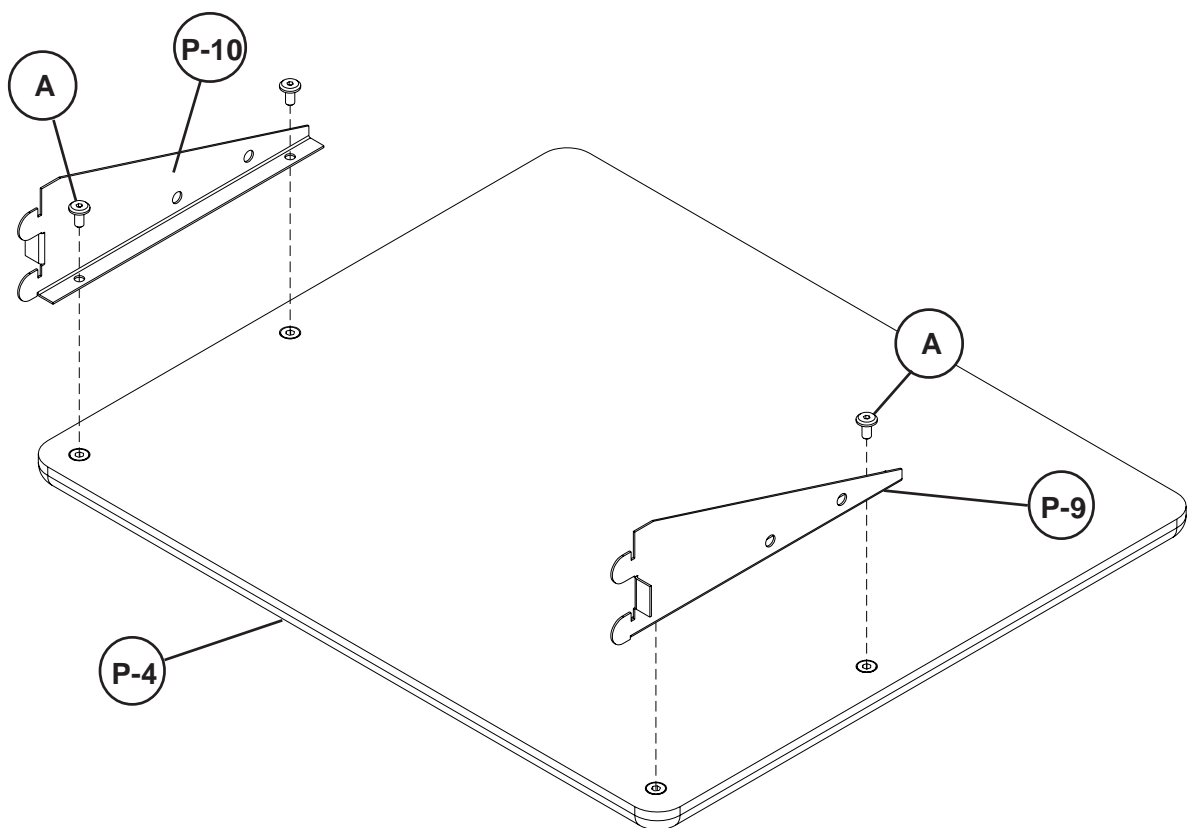
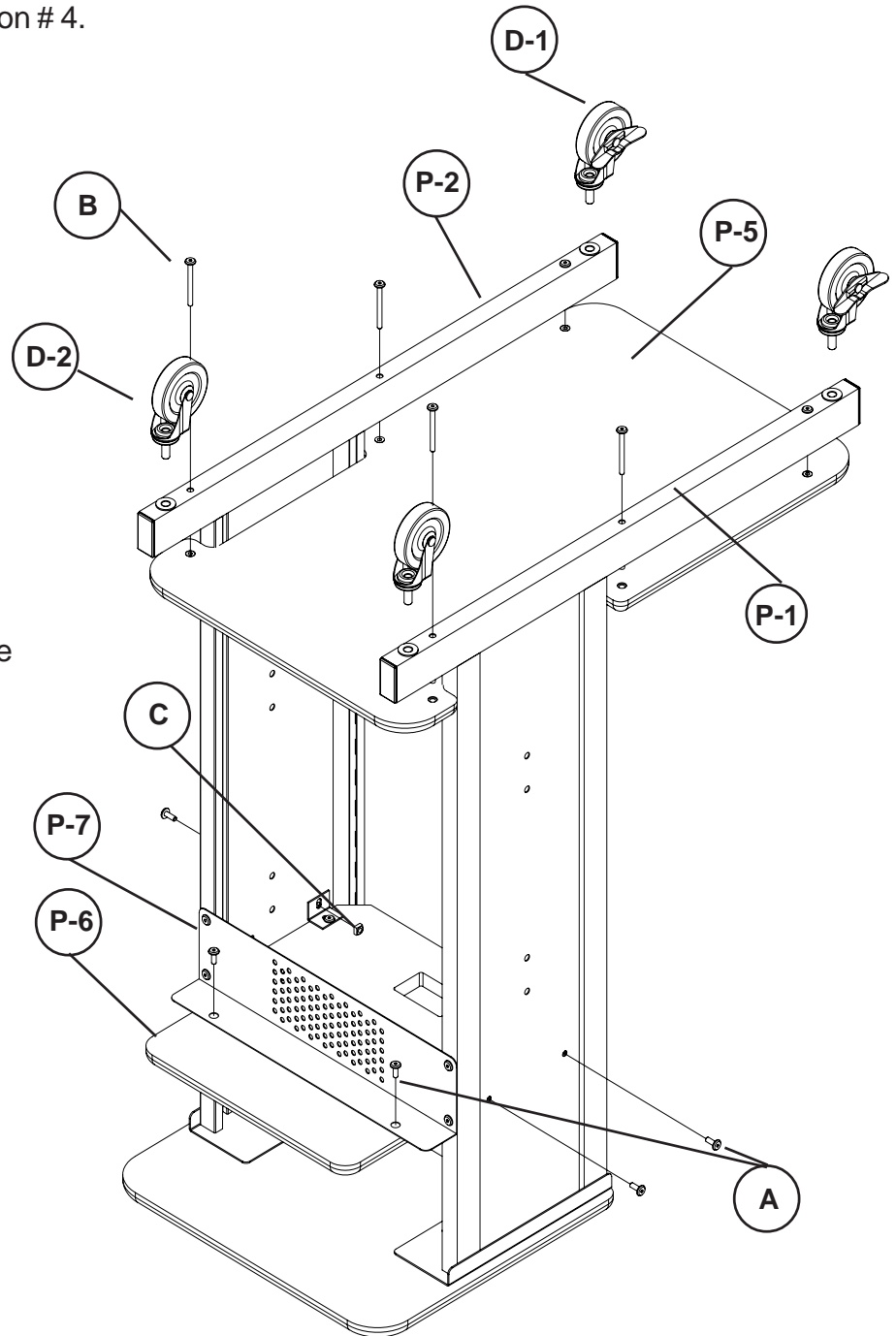

Illustration # 3

- 6.) Attach Lower Shelf (P-5) to the Right & Left Leg Assemblies (P1 & P2) using 4 each (B) screws as shown in illustration # 4.  
**(Finger tighten only)**



- 7.) Attach 2 Locking Casters (D-1) to the front of the unit. Attach 2 Casters (D-2) to the back of the unit. Tighten all Casters using Caster Wrench (G).

- 8.) Slide Middle Shelf (P-6) Between Right & Left Leg Assemblies (P-1 & P-2) and attach Middle Shelf (P-6) using 4 each (A) screws and 4 each (C) Square Nuts as shown in illustration # 4. Secure Middle Shelf (P-6) to Stability Panel (P-7) using two screws (A).

- 9.) *(Tighten all the screws at this time using Allen Wrench (F)).*

- 10.) To install Grommets (E) in LCD Platform (P-3) and Middle Shelf (P-6), separate parts and press Grommet Sleeve in rectangular openings as shown in illustration # 5.
- 11.) Snap 2 plastic Caps over top of Sleeve as shown in illustration # 5.

**Grommet(E) installation  
Illustration # 5**

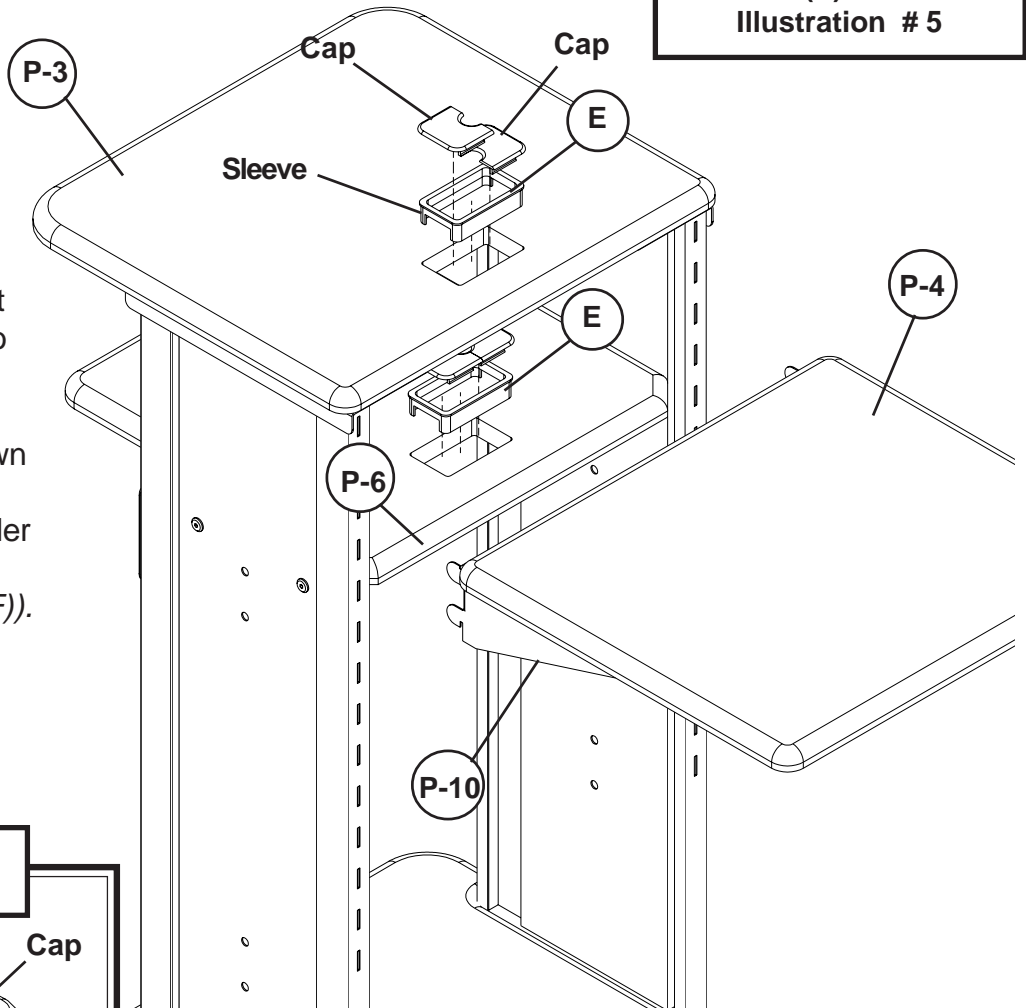

- 12.) Attach Right Shelf Bracket (P-9) and Left Shelf Bracket (P-10) to the Right & Left Leg Assemblies at the desired height as shown in illustration # 5.  
(Tighten 4 screws under Laptop Shelf (P-4) using Allen Wrench (F)).

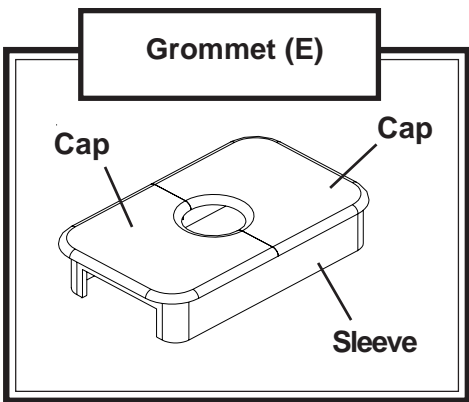

**Important**

The Balt product you have purchased is guaranteed against material and workmanship defects. This guarantee extends 1 year from date of purchase. Should this product fail to function satisfactorily under normal use due to defect or imperfection, the defective part or product will be replaced. Damage caused by common carriers during shipment is not included in this guarantee.



**This guarantee sets forth all applicable guarantees and remedies. No other warranty, expressed or implied shall apply. Failure to follow instructions found in Important Information Section of Owner Sheet shall void the guarantee. Consequential or incidental damages and or costs are not refundable.**

# #66450

## 4 Outlet Electrical Assembly Diagram

***This 4 Outlet Electrical is Part # 66450  
and must be purchased separately.  
Please contact our  
Customer Service Department  
Monday - Friday  
8 a.m. - 5 p.m.  
Central Standard Time  
1-800-749-2258***

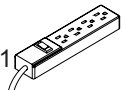
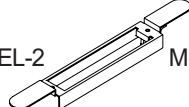
### Parts/Hardware List

|      |  |                             |      |
|------|--|-----------------------------|------|
| EL-1 |   | Electric Outlet             | 1 EA |
| EL-2 |  | Metal Bracket w/Cord Winder | 1 EA |
| EL-3 |   | Phillips Head Screw         | 2 EA |
| EL-4 |   | Hex Nut                     | 2 EA |

1.) Identify and Separate all the Parts and Hardware.

2.) Slide Metal Bracket over the Electrical Outlet (EL-1) as shown. (note that Metal Stop is at the end with the electrical Plug-in.)

3.) Attach Metal Bracket (EL-2) to the Right or Left Leg Assembly (P-1 or P-2) using 2 Phillips Head Screws (EL-3) and 2 Hex Nuts (EL-4) as shown in Optional Electrical illustration.

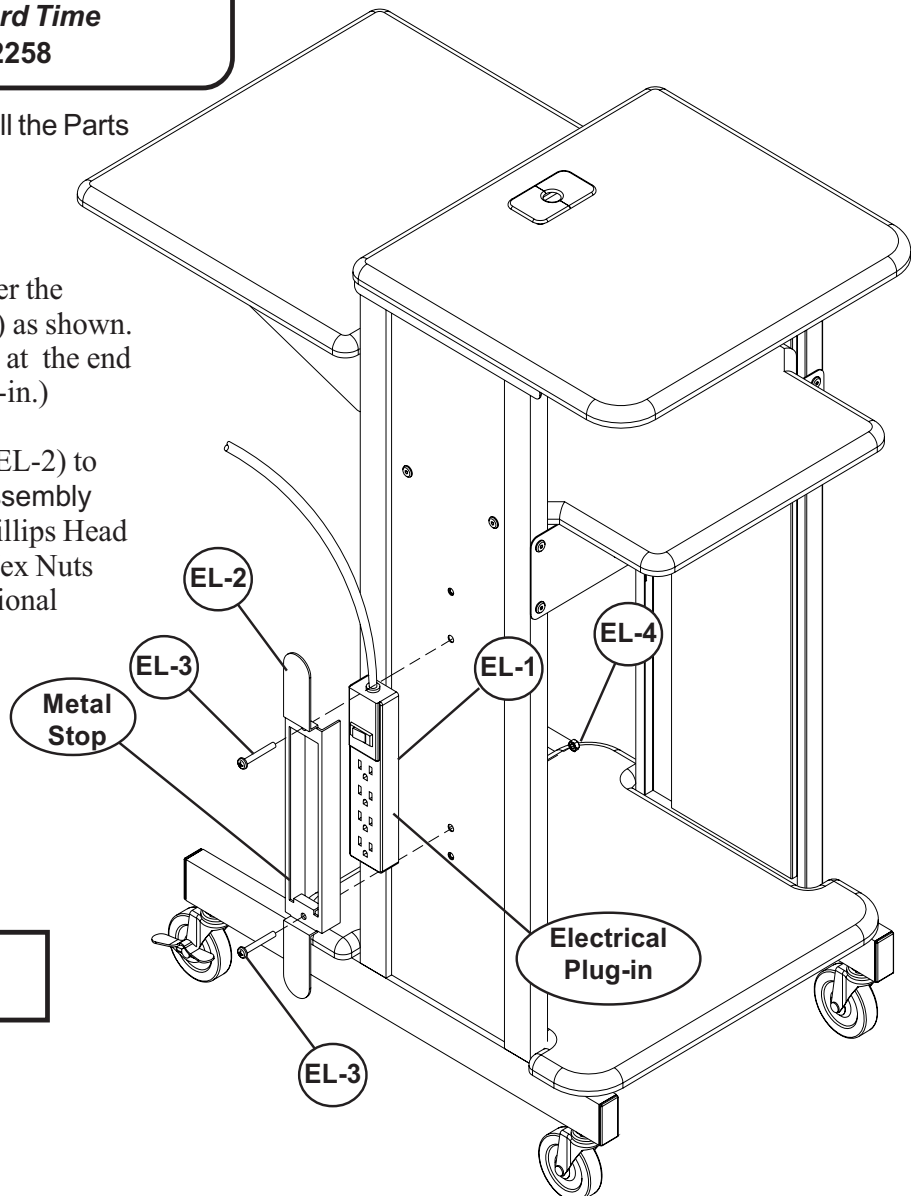

**Optional Electrical  
Illustration**



# #66572

## 7 Outlet Electrical Assembly Diagram

*This 7 Outlet electrical is Part # 66572  
and must be purchased separately.*

*Please contact our  
Customer Service Department  
Monday - Friday  
8 a.m. - 5 p.m.  
Central Standard Time  
1-800-749-2258*

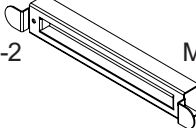
### Parts/Hardware List

|      |   |                             |      |
|------|---|-----------------------------|------|
| EL-1 |  | 7 Outlet Electrical         | 1 EA |
| EL-2 |  | Metal Bracket w/Cord Winder | 1 EA |
| EL-3 |  | Phillips Head Screw         | 2 EA |
| EL-4 |  | Hex Nut                     | 2 EA |

1.) Identify and Separate all the Parts  
and Hardware.

2.) Slide Metal Bracket over the  
Electrical Outlet (EL-1) as shown.  
(note that Metal Stop is at the end  
with the electrical Plug-in.)

3.) Attach Metal Bracket (EL-2) to the  
Right or Left Leg Assembly  
(P-1 or P-2) using 2 Phillips  
Head Screws (EL-3) and 2 Hex  
Nuts (EL-4) as shown in  
Optional Electrical illustration.

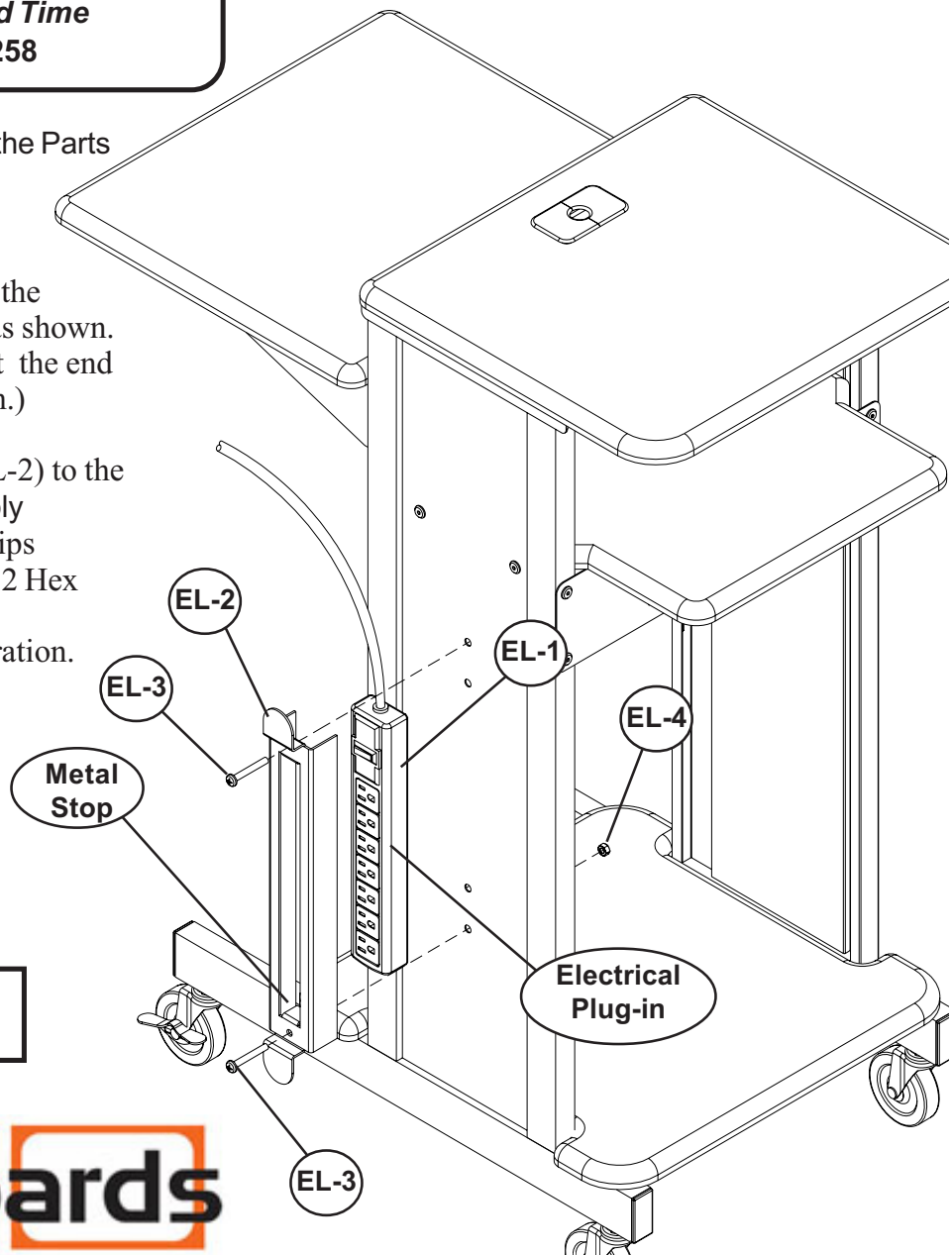

Optional Electrical  
Illustration

# Touchboards

205 Westwood Ave, Long Branch, NJ 07740  
Phone: 866-94 BOARDS (26273) / (732)-222-1511  
Fax: (732)-222-7088 | E-mail: sales@touchboards.com