



#34422

Executive Chair





We've Got Your Back®

Missing Parts or UPS Damaged Parts
For Your Convenience you can
EMAIL us at
support@moorecoinc.com
24HOURS 7 DAYS A WEEK

*Should you require assistance
during assembly,
please call our Customer Service
Department Monday - Friday
8 a.m. - 5 p.m.
Central Standard Time
1-800-749-2258*

Parts/Hardware

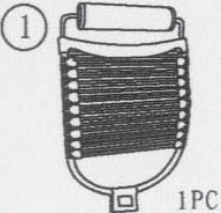
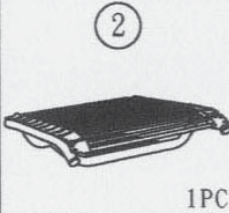

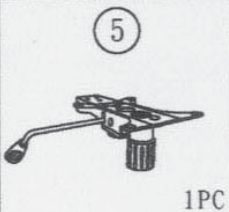
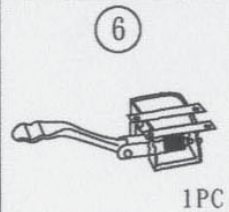
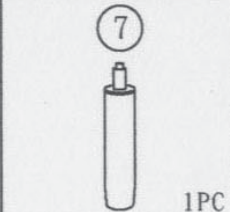
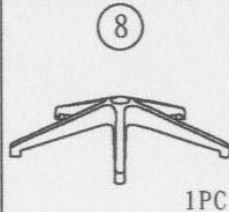
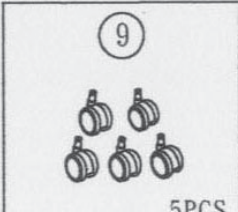
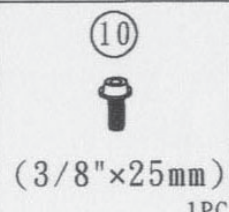
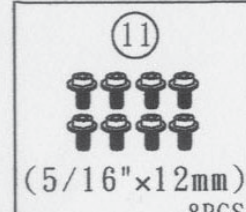
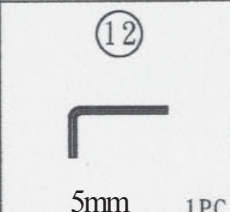
 1 PC	 1 PC	 1 PC	 1 PC
 1 PC	 1 PC	 1 PC	 1 PC
 5PCS	 (3/8"×25mm) 1PC	 (5/16"×12mm) 8PCS	 5mm 1PC

Do not use unless all screws are tight. At least every six months, check all screws to be sure they are tight. If parts are missing, broken, damaged, or worn, stop use of the product until repairs are made by your dealer using factory authorized parts.

#34422 Executive

STEP 1

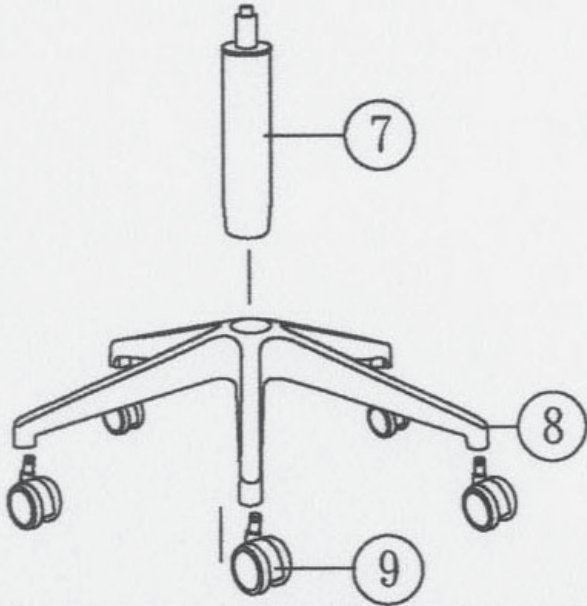

STEP 2

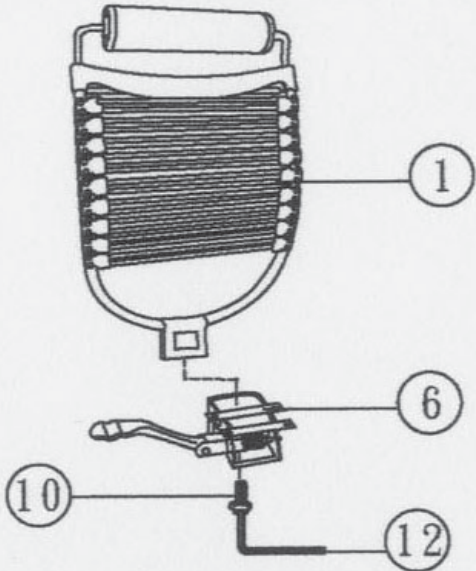

STEP 3

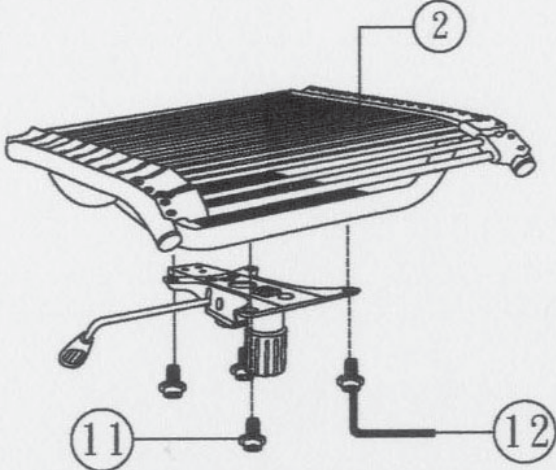

#34422 Executive

STEP 4

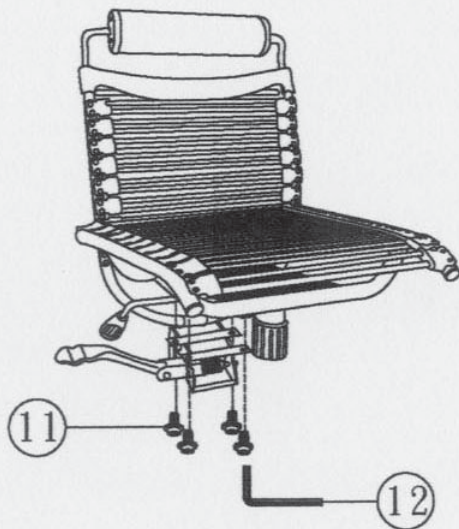

STEP 5

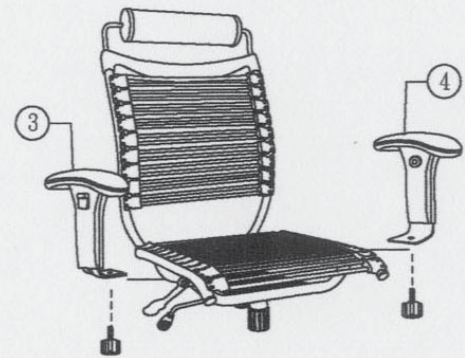

Step 6



Touchboards

205 Westwood Ave, Long Branch, NJ 07740
Phone: 866-94 BOARDS (26273) / (732)-222-1511
Fax: (732)-222-7088 | E-mail: sales@touchboards.com

Important

The Balt product you have purchased is guaranteed against material and workmanship defects. This guarantee extends 1 year from date of purchase. Should this product fail to function satisfactorily under normal use due to defect or imperfection, the defective part or product will be replaced. Damage caused by common carriers during shipment is not included in this guarantee.

This guarantee sets forth all applicable guarantees and remedies. No other warranty, expressed or implied shall apply. Failure to follow instructions found in Important Information Section of Owner Sheet shall void the guarantee. Consequential or incidental damages and or costs are not refundable.