

## Evolution (electric) eFPM Desk

38945	Single eFPM Desk (39"W)
38946	Double eFPM Desk (72"W)
38947	ADA eFPM Desk (39"W)

# Touchboards

205 Westwood Ave, Long Branch, NJ 07740  
Phone: 866-94 BOARDS (26273) / (732)-222-1511  
Fax: (732)-222-7088 | E-mail: sales@touchboards.com

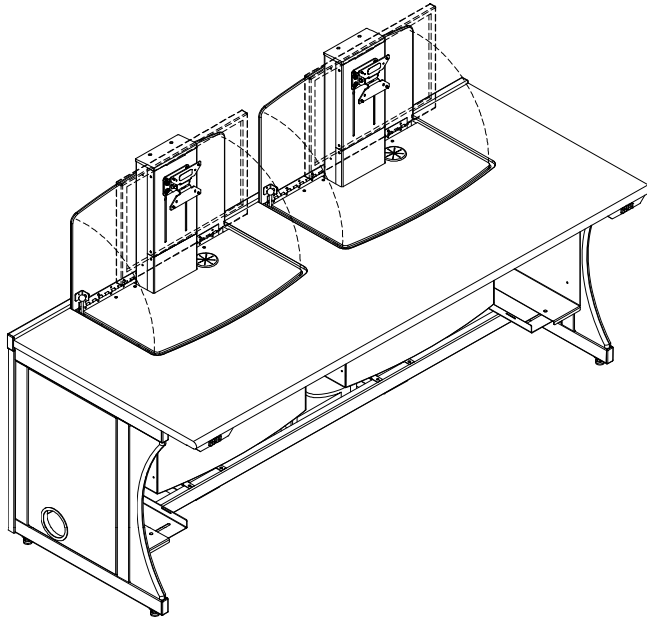

38946  
eFPM Double Desk

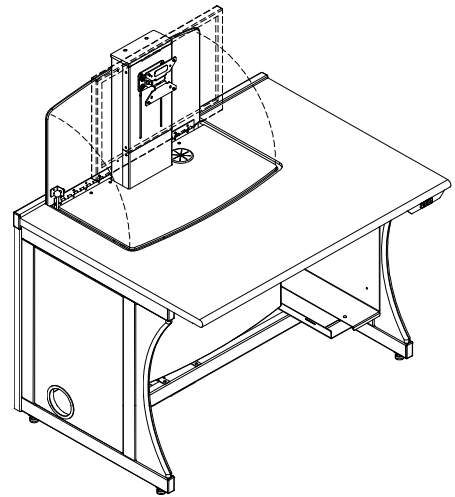

38945  
eFPM Single Desk

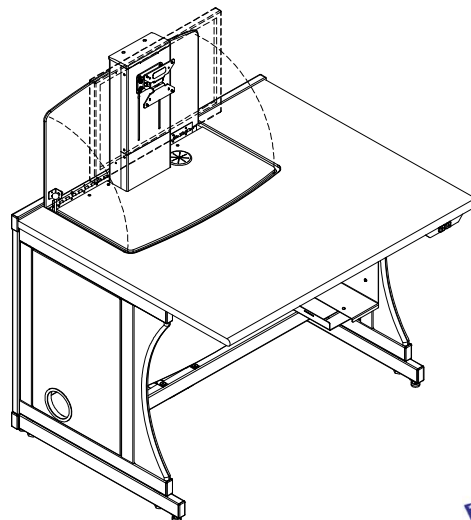

38947  
eFPM ADA Desk

### **IMPORTANT:**

Before you begin, please make sure all parts and proper quantities are included. Any parts damaged during shipment must be reported within 15 days of receipt. To report information regarding damages or if you have any questions, please call 1-800-235-1262.

### **CAUTION:**

Before using this product, read this manual and follow all safety and operating instructions.

To purchase parts or accessories, please contact us at  
[www.spectrumfurniture.com](http://www.spectrumfurniture.com)  
1-800-235-1262

Thank you for choosing Spectrum products!





## Safety



Read this owners manual before assembling or operating this desk.  
 Keep fingers and hands away from the edges of monitor compartment lid and clear of the lift mechanism when raising or lowering to prevent pinching.  
 Do not sit or allow students to sit on top of desk or monitor compartment lid.  
 Do not exceed the maximum monitor weight rating of 50 lbs per lift.

## Hardware package contents

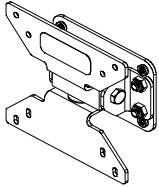

**Standard Swivel VESA Monitor Mount w/ internal travel stops**  
 provides 4-direction tilt, and works with 75mm and 100mm VESA monitor mounts (includes mounting screws)

(1) 0107624 w/ single desks  
 (2) 0107624 w/ double desks



(2) 052605  
 1/4-20 x 15mm JC Bolts



(1) 025039  
 4mm Hex wrench



054403  
 10-24 X 1/2" FHMS  
 (4) single desk  
 (8) double desk



054781  
 10-24 X 1/2" PHMS  
 (4) single desk  
 (8) double desk

## Assembly / Setup

### 1. Installing Monitor

- Plug in unit. Raise the monitor column up all the way using the button, then unplug the power.
- Remove the monitor column cap by removing the (2) 10-24 x 1/2" FHM screws. **Figure 1A.**
- Detach the monitor mounting bracket from the desk by removing the (4) 10-24 x 1/2" PHM screws shown.

#### Tools Required



Phillips Screwdriver

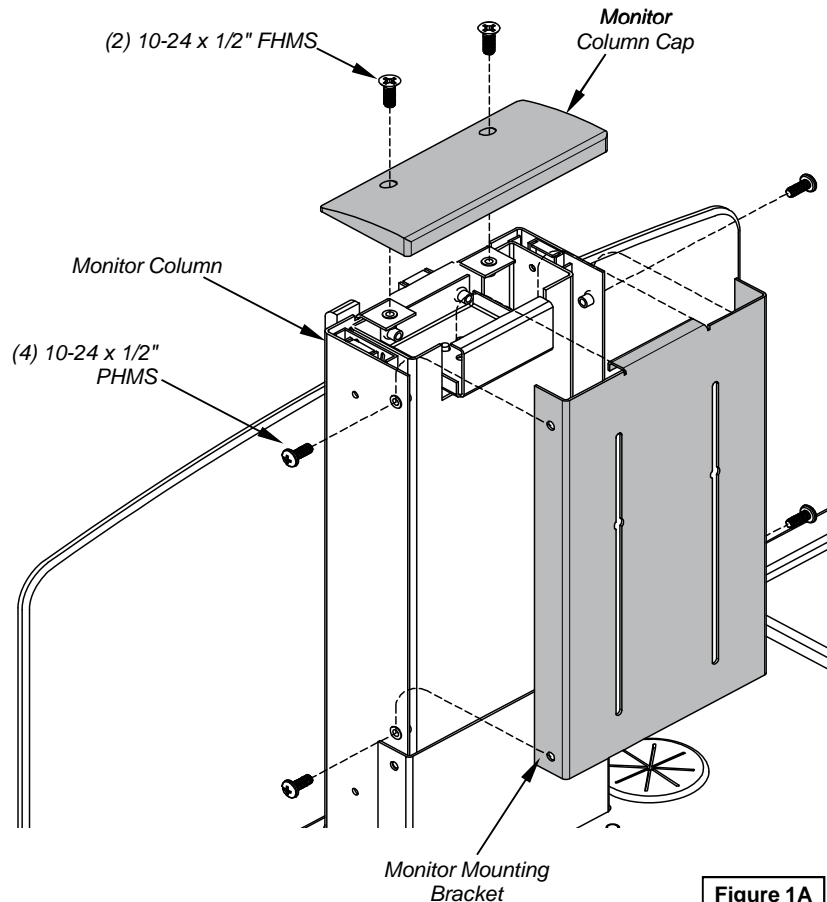

Figure 1A

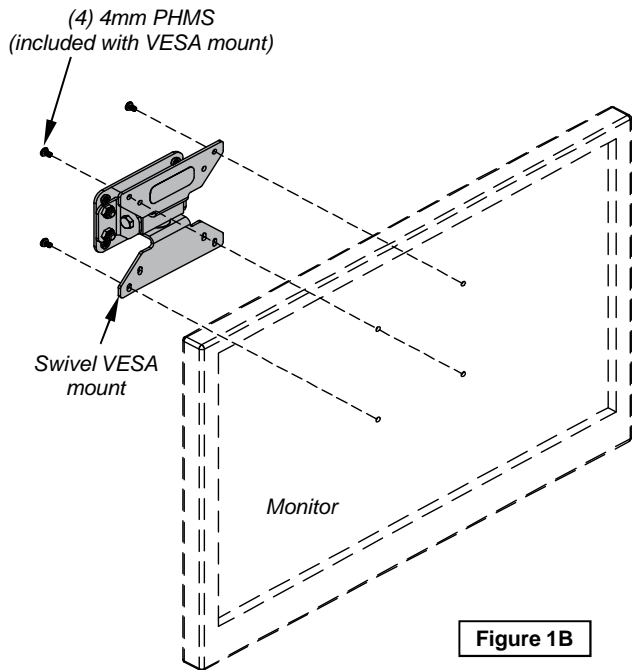

Figure 1B

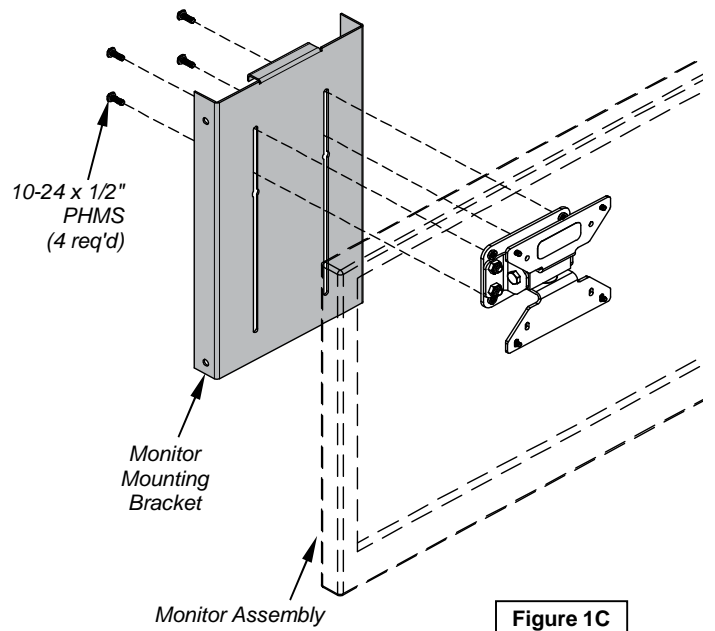

Figure 1C

- D. Attach the swivel VESA mount to the back of your flat panel monitor using the 4mm PHM screws included with the VESA plate. **Figure 1B.**  
**Note:** On most flat panel monitors, it will be necessary to remove the standard base that comes with the monitor to use the VESA mount.
- E. Attach the monitor assembly to the monitor mounting bracket with (4) 10-24 x 1/2" PHM screws as shown in **Figure 1C.**
- F. Position the top of the monitor mounting bracket with the top of the monitor to and tighten the 10-24 x 1/2" PHM screws.  
**Note:** The top of the monitor cannot extend past the top of the monitor column cap.
- G. Hook the monitor mounting bracket with the attached monitor onto the column and re-assemble with the (4) screws taken out in Step C. See **Figure 1A.**
- H. Replace monitor column cap and screws. Tighten all screws securely.

## 2. Cord Management

- A. Remove the back panel to access cords.
- B. Use a standard flat head screwdriver to pry open the loop clip to release the wire loom. **Figure 2A.**
- C. Remove the wire loom from the clip and route cords through the sliced opening on the loom. **Figure 2B.**
- D. After the cords are installed, replace the wire loom into the clip and snap close.



Figure 2A



Figure 2B

### 3. Installing CPU

1. Set the CPU unit into the CPU sling.
2. Make sure the CPU will be supported by both straps. Tighten the straps around the CPU while keeping the buckles positioned as high as possible to avoid interference. **Figure 3A.**

**Note:** The center slot can be used for better support of smaller profile CPU's. If the center slot is necessary, take the rear strap out of the rear slot and thread into the center slot shown in **Figure 3A**. Thread the strap as shown in **Figure 3B**.

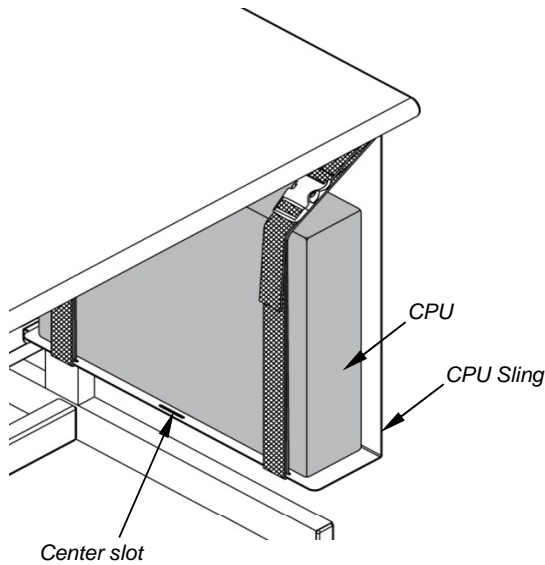

Figure 3A

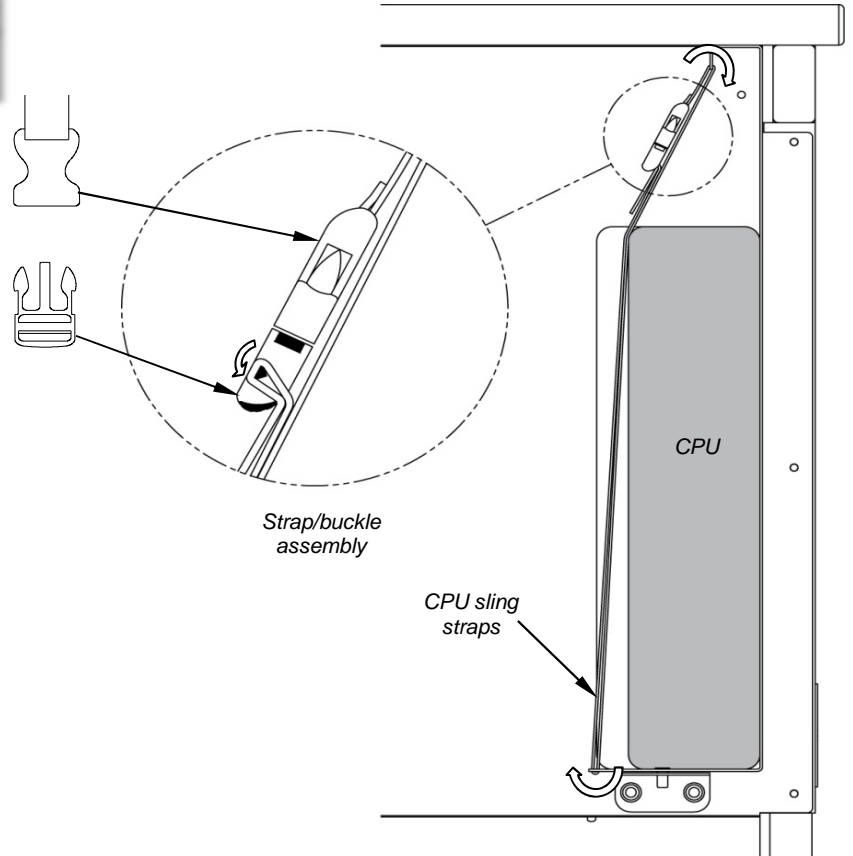

Figure 3B

### Lift Mechanism Operation

#### Normal Operation:

To raise or lower the monitor, press and hold the "up" or "down" arrow keys on the control pad until the worksurface reaches the desired height. **Figure 4.**

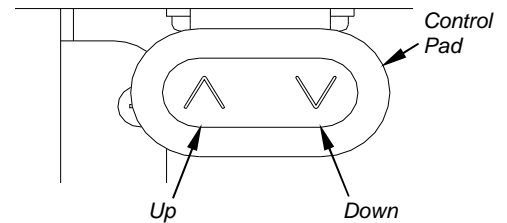

Figure 4



Although this desk utilizes a safety device that briefly stops and reverses the motion of the column in the event of an obstruction, use caution when raising or lowering the unit. Be sure keyboards and other items are fully inside platform area and column motion does not interfere with objects or people.



Keep clear of pinch points during worksurface movement.

## Resetting lift mechanism

**Note:** Occasionally it may be necessary to reset the lift mechanism. This should be performed if the monitor column does not extend or retract.

### Reset Procedure:

1. Unplug, then re-plug-in the power cord into a wall outlet or power strip.
2. Make sure all lift mechanism wire connections are in place and secure.
3. Press and hold the "down" button until the monitor column has bottomed-out for 10 seconds.
4. Release, then press and hold the "Down" button again for another 10 seconds.
5. Release the "down" button.

The lift mechanism has now been reset and normal operation can resume.

## Connecting desks together

- A. Arrange the desks side-to-side in their final location.
- B. The unit-to-unit bracket is pre-assembled to the desk with (1) JC Bolt. Loosen the installed JC bolt, rotate and align the bracket with the adjacent desk mounting hole as shown. **Figure 5.**
- C. Secure the bracket to the second worksurface with (1) 1/4-20 x 15mm JC Bolt. Tighten both bolts securely.

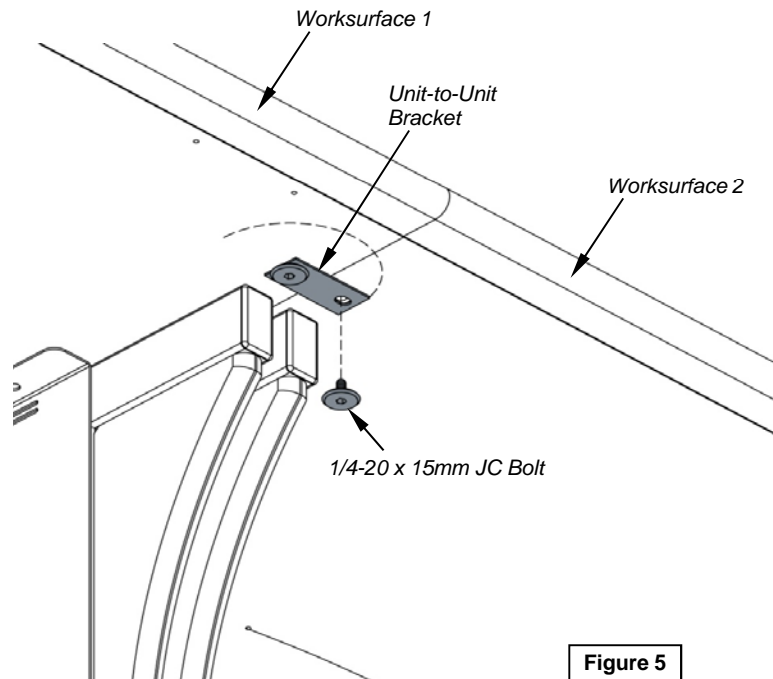
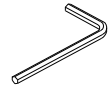

Figure 5

### Tools Required



4mm Hex Wrench  
(included)

## Optional Accessories



Replacement Key Set  
55142

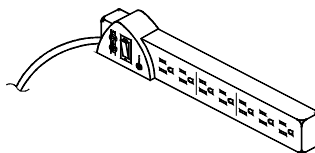

7-Outlet Power Strip, insured  
w/surge protector, and 12' cord  
10"W x 2"D x 1 1/8"H  
99024

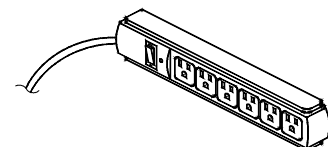

6-Outlet Power Strip  
w/ 12' cord  
11 5/16"W x 1 1/16"D x 1 3/16"H  
99023

## Warranty

### **WE WILL MAKE IT RIGHT FOR YOU!**

We guarantee all Spectrum products to be free of all defects in materials and workmanship, for the original owner, for a period of **ten years**. Any item deemed defective by Spectrum or the original manufacturer, under normal use conditions, will be repaired or replaced at Spectrum's discretion. This warranty applies to all products manufactured and distributed by Spectrum except the products listed below.

**DESIGNED FOR INDOOR USE ONLY** - Spectrum's products have been designed and constructed for indoor use only. Moving or using outdoors, or on excessively rough surfaces, may cause damage to the products and may void the warranty. If an outdoor application is desired please contact us to discuss potential custom design solutions.

Spectrum is committed to provide complete customer satisfaction. Each of our products are manufactured from the best materials available and each product is stringently monitored throughout the production process through our P.A.C.E. program (Product Assurance to meet Customer Expectations).

Our Customer Service Help Line 1-800-235-1262 is ready to provide immediate attention to any questions, comments or concerns. We are available to answer your calls Monday through Friday from 7 am to 5 pm CST. In addition your product comments or concerns are welcome via e-mail at: [spectrum@spectrumfurniture.com](mailto:spectrum@spectrumfurniture.com).

Items that have a varying warranty include, but are not limited to, the following:

- Adjustable Crank/Electric Desk Legs (1 yr)
- Flat Panel Desk Gas Cylinders (1 yr)
- Adjustable Height Chair Parts – including frames, gas cylinders, wood and plastic parts, and control handles (7 yrs)
- Adjustable Height Chair Parts Casters (2 yrs)
- Adjustable Height Chair Upholstery - In-Stock Upholstery (2 yrs)
- Adjustable Height Chair Upholstery - Graded-In Fabrics and C.O.M (no warranty)
- Height Adjustable Columns and Lifts (1 yr)
- General Use Casters (1 yr)
- Electrical – ECA (1 yr)
- Electrical - Power Strips (1 yr)
- Electrical Surge Suppressors (lifetime)
- Electrical - Retractable Power Cords (1 yr)
- Keyboard/Mouse Trays (1 yr)
- Flat Panel Monitor Arm – General Parts (5 yrs)
- Flat Panel Monitor Arm – Gas Cylinders (2 yrs)
- CRT Monitor Arm (1 yr)

The warranty, as stated above, is effective as of 05/28/2009

# Touchboards

205 Westwood Ave, Long Branch, NJ 07740

Phone: 866-94 BOARDS (26273) / (732)-222-1511

Fax: (732)-222-7088 | E-mail: [sales@touchboards.com](mailto:sales@touchboards.com)

