

# Televes® CATV

**Central Amplificadora  
Central Amplificadora  
Amplificateur Multibandes  
Compact B.B. Amplifier**  
Refs. 4511, 4513, 451301

Instrucciones de seguridad	Instruções de segurança	Instructions de sécurité	Safety instructions
Los terminales de entrada y salida de alimentación son peligrosos al tacto y requieren ser conectados por una persona cualificada.	Os terminais de entrada e saída de alimentação são perigosos ao tacto e requerem ser ligados por uma técnico credenciado.	Les bornes de l'entrée et de la sortie de l'alimentation sont dangereuses au tact et doivent être reliées par une personne qualifiée.	The input and output terminals are dangerous to the tact and it require a qualified person to be connected.

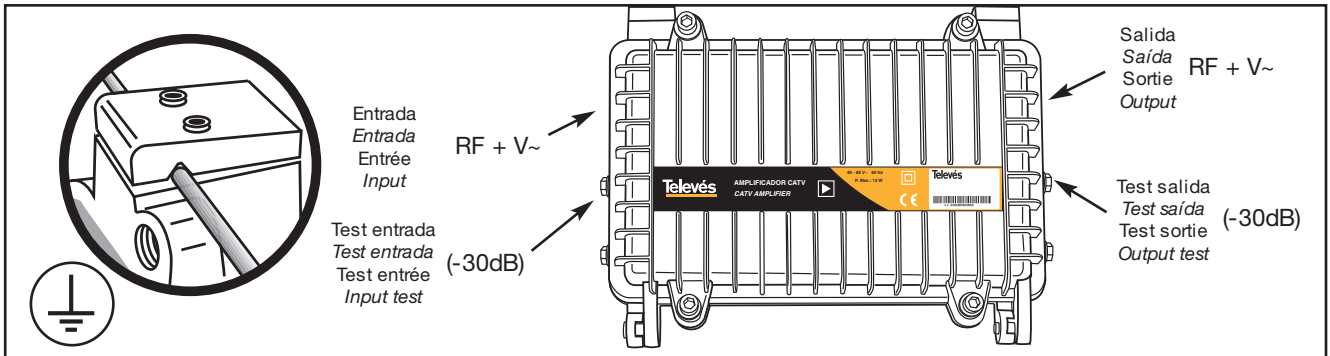

Central realizada en chasis zamak blindado para intempérie, configurable en ganancia por el propio instalador.

Estas refs. tienen su aplicación como amplificadores de cabecera o línea en sistemas de CATV.

Central blindada alojada em chasis de zamak para intempérie, configurável em ganho pelo próprio instalador.

Estas refs. teñen a sua aplicação como amplificadores de cabeça ou de linha em redes de CATV.

Amplificateur réalisé en châssis de zamak pour intempérie. Le gain peut être choisi sur le site.

L'application principale de cette amplificateurs est comme unité d'extension de ligne dans de petit réseaux de CATV.

This product has been manufactured in a fully shielded diecast chassis and the gain can be selected on site.

The main application of these amplifiers is as a line extender in small CATV networks.

Características técnicas	Características técnicas	Caractéristiques techniques	Technical specifications			
Referencias	Referencias	Références	References	4511	4513	451301
Canal principal	Canal principal	Canal voie principale	Forward path			
Rango frecuencias	Largura de banda	Bande de fréquence	Frequency range (MHz)	47 - 862	87,5 - 862	87,5 - 862
Atenuador	Atenuador	Attenuateur	Attenuator (dB)	0 - 20		
Ecualizador cable	Equalizador cabo	Correcteur de pente	Cable equaliser (dB)	0 - 20		
Preacentuador	Preacentuador	Préaccentuateur	System equaliser (dB)	0 - 20		
Ganancia	Ganho	Gain	Gain (dB)	36 (1)		
Nivel de salida	Nível de saída	Niveau de sortie	Max.output level (DIN 45004B) (dB $\mu$ V)	> 118 (121 typ)		
Distors. 2º orden	Distors. 2º orde	2ème ordre	2nd order distortion (dB=-60 dB) (dB)	> 110 (> 113 typ)		
Nivel salida	Nível saída	Niveau de sortie	Max.output level (dB $\mu$ V)	105 (2)		
Figura de ruido	Figura de ruído	Facteur de bruit	Noise figure (dB)	8 typ.		
Pérfid. retorno E-S	Perdas retorno E-S	Pertes retour E-S	In-Out return losses (dB)	14 typ.		
Planicidad	Planicidade	Linéarité	Flatness (dB)	$\pm$ 1 typ.		
Canal retorno	Canal retorno	Canal voie de retour	Return path			
Rango frecuencias	Largura de banda	Bande de fréquence	Frequency range (MHz)	5 - 30	5 - 65	5 - 30 36 - 65
Atenuador	Atenuador	Attenuateur	Attenuator (dB)	0 - 20	-	0 - 20
Ganancia	Ganho	Gain	Gain (dB)	12	-3	12
Planicidad	Planicidade	Linéarité	Flatness (dB)	$\pm$ 1		
Pérfid. retorno E-S	Perdas retorno E-S	Pertes retour E-S	In-Out return losses (dB)	14		
General	Geral	General	General			
Tensión de aliment.	Tensão de aliment.	Tension d'alimentation	Powering voltage (V-)	40 ... 60		
Paso corriente E-S	Paso corrente E-S	Passage courant E-S	In-Out AC current bypass (A-)	5 max.		
Consumo	Consumo	Consommation	Power consumption (W)	15 (60V-)		
Índice protección	Índice protecção	Indice protection	Protection level	IP 67		

(1) Con módulo amplificador.  
26 dB sin módulo.

Com módulo amplificador.  
26 dB sem módulo.

Avec module amplificateur.  
26 dB sans module.

With plug-in module amplifier.  
26 dB without amplifier.

(2) 42 TV CH CENELEC EN50083-3

Opciones de aliment.	Opções de aliment.	Options d'alimentat.	Power supply options		
Puentes	Pontes	Pontets	Bridges	P1	P2
Por entrada	Por entrada	Par entrée	Via input	ON	OFF
Por salida	Por saída	Par sortie	Via output	OFF	ON
Por entrada o salida + paso V~	Por entrada ou saída + passagem V~	Par entrée ou sortie + passage V~	Via input or output plus V~ bypass	ON	ON

# Televes® CATV

**Central Amplificadora**  
**Central Amplificadora**  
**Amplificateur Multibandes**  
**Compact B.B. Amplifier**  
Refs. 4511, 4513, 451301

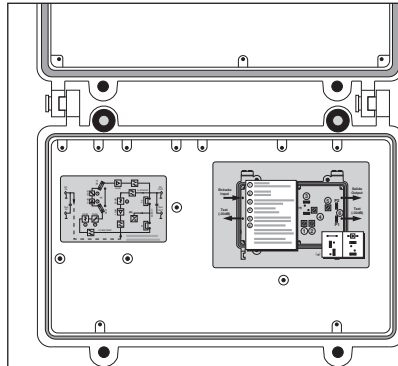
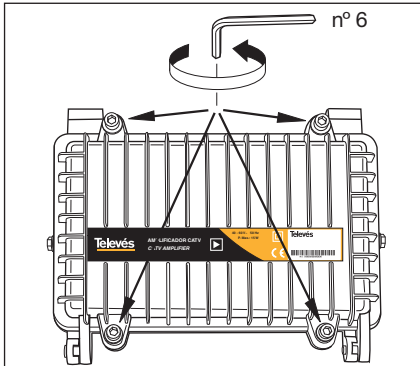

Bajo la tapa se encuentra el diagrama de bloques y las instrucciones de configuración.

Baixo a tampa encontra-se o diagrama de blocos e as instruções de configuração.

Sous le couvercle se trouve le diagramme des fonctions et les instructions de configuration.

Undemeath the front cover please find a block diagram of the amplifier as well as the configuration instructions.

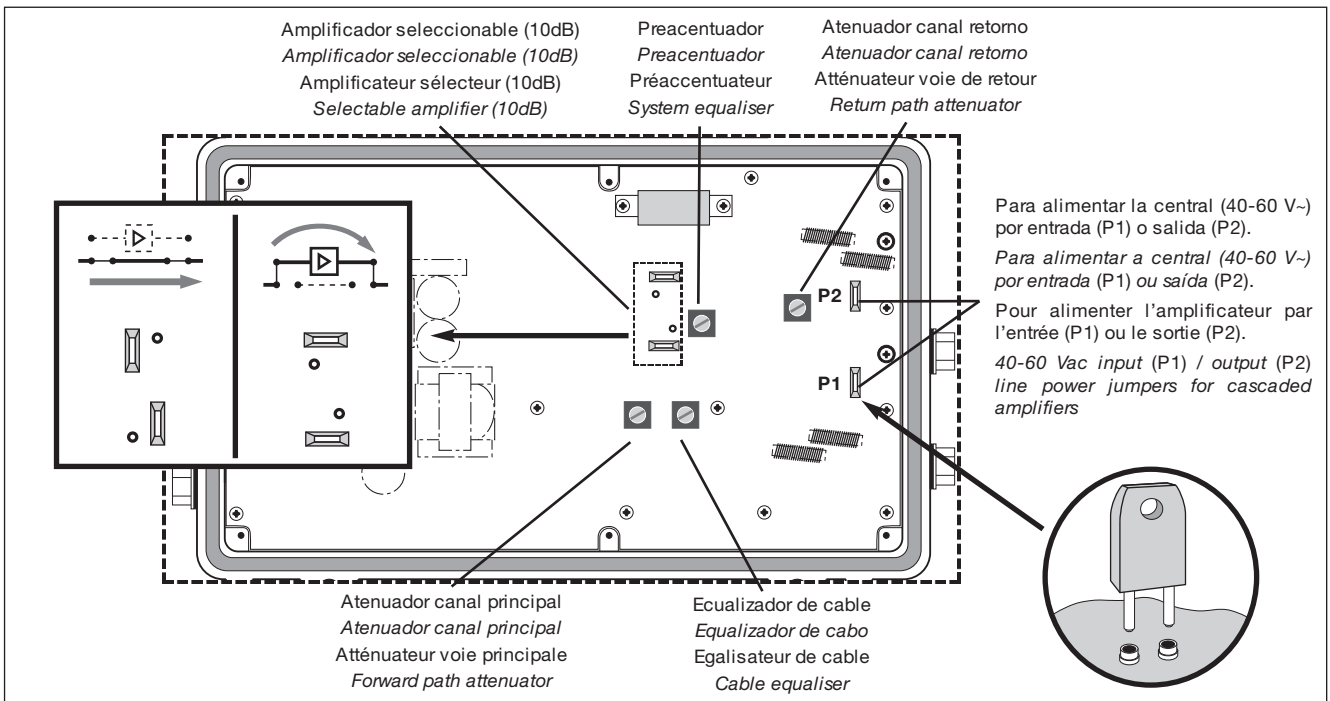

## Ejemplo de aplicación

## Exemplo de aplicação

## Exemples d'application

## Typical application

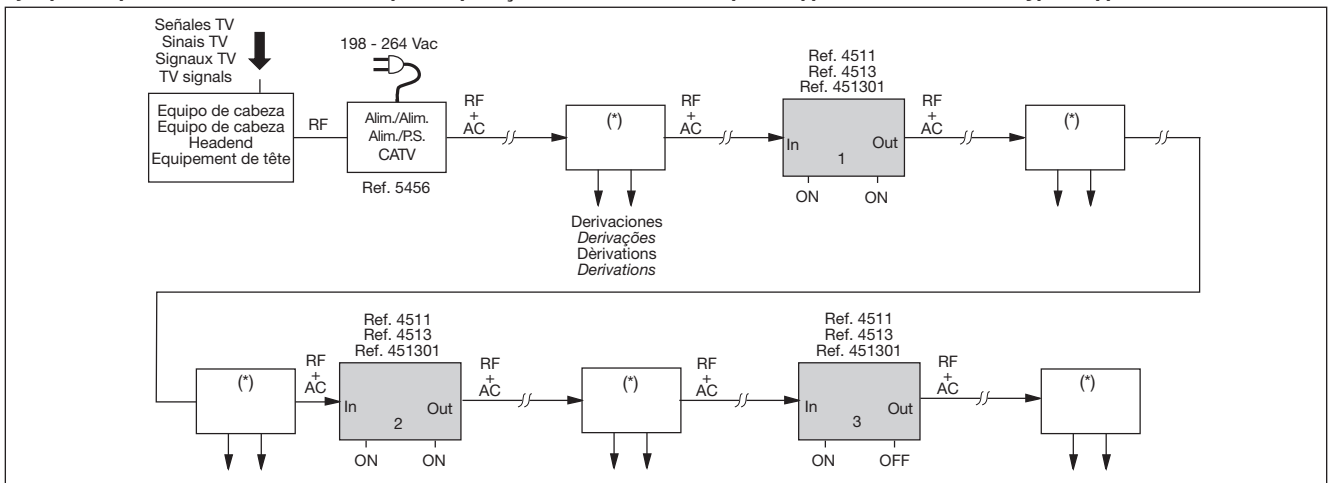

(\*) Derivadores / Derivadores / Dérivateurs / Taps

CATV 2D Refs. 4601, 4602, 4603, 4604, 4605, 4606, 4607, 4608, 4609, 4610, 4611

CATV 4D Refs. 4612, 4613, 4614, 4615, 4616, 4617, 4618, 4619, 4620

<b>Televés</b>	<b>DECLARACIÓN DE CONFORMIDAD DECLARAÇÃO DE CONFORMIDADE DECLARATION DE CONFORMITE DECLARATION OF CONFORMITY</b>
<p>Fabricante / Fabricante / Fabricant / Manufacturer: <b>Televés S.A.</b>                  Dirección / Direção / Adresse / Address: <b>Rúa B. Conxo, 17 15706 Santiago de Compostela SPAIN A-15010176</b></p> <p>NIF / VAT: _____</p> <p>Declara bajo su exclusiva responsabilidad la conformidad del producto:                  Declara sob sua exclusiva responsabilidade a conformidade do produto:                  Declare, sous notre responsabilité, la conformité du produit:                  Declare under our own responsibility the conformity of the product:</p> <p>Referencial / Referencia / Référence / Reference: <b>4511</b>                  Marca / Marca / Marque / Mark: <b>Televés</b></p> <p>Con los requerimientos de la Directiva de baja tensión 73 / 23 / CEE y Directiva EMC 89 / 336 / CEE, modificadas por la Directiva 93 / 68 / CEE, para cuya evaluación se ha utilizado las siguientes normas:</p> <p>Com as especificações da Directiva da baixa tensão 73 / 23 / CEE e Directiva EMC 89 / 336 / CEE, modificadas pela Directiva 93 / 68 / CEE, para cuja aprovação se aplicou as seguintes normas:</p> <p>Avec les spécifications des Directives 73/ 23 / CEE et 89 / 336 / CEE, modifiées par la directive 93 / 68 / CEE, pour l'évaluation on a appliqué les normes:</p> <p>With the Low Voltage Directive 73 / 23 / EEC and the EMC Directive 89 / 336 / EEC as last amended by Directive 93 / 68 / EEC requirements, for the evaluation regarding the Directive, the following standards were applied:</p> <p style="text-align: center;"><b>EN 60065: 1998                  EN 50083-1: 1993 / A1: 97                  EN 50083-2: 1995 / A1: 97                  EN 61000-4-2: 1995                  EN 61000-4-4: 1995                  EN 61000-4-5: 1995                  EN 61000-4-11: 1994</b></p> <p style="text-align: center;">Santiago de Compostela, 28/10/2003</p> <div style="text-align: center;">                   José L. Fernández Carnero                  Technical director             </div>	

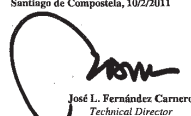

<b>Televés</b>	<b>DECLARATION OF CONFORMITY N° 110210135451</b>
<p>DECLARACIÓN DE CONFORMIDAD                  DECLARAÇÃO DE CONFORMIDADE                  DECLARATION DE CONFORMITE                  DICHIARAZIONE DI CONFORMITÀ</p> <p style="text-align: right;">KONFORMITÄTSERKLÄRUNG                  ΠΙΣΤΟΠΟΙΗΤΙΚΟ ΣΥΜΜΟΡΦΩΣΗΣ                  FÖRSÄKRAN OM ÖVERENSSTÄMMELSE                  VAATIMUSTENMUKAISUUSVARUUTUS</p> <p>Manufacturer / Fabricante / Fabricante / Fabricant / Fabricante / Fabrikant / Käyttäjänvastuut / Tilverkare / Valmistaja: <b>Televés S.A.</b></p> <p>Address / Dirección / Direção / Adresse / Indirizzo / Adresse / Διεύθυνση / Address / Osioite: <b>Rua Benéfica de Conxo, 17 15706 - Santiago de Compostela Spain A-15010176</b></p> <p>VAT / NIF / NIF / VAT / VAT / Steuernummer / AΦM / Mons / ALY: _____</p> <p>Declare under our own responsibility the conformity of the product / Declara bajo su exclusiva responsabilidad la conformidad del producto / Declara sob sua exclusiva responsabilidade a conformidade do produto / Déclare sous notre propre responsabilité la conformité de ce produit / Dichiaro sotto la sua esclusiva responsabilità la conformità del prodotto / Wir übernehmen die Verantwortung für die Konformität des Produktes / Πιστοποιώ με δικιά μας ευθύνη την συμμόρφωση του προϊόντος / Försäkrar om överensstämmelse enligt tillverkarens eget ansvar för produkten / Vakuutanne yksinomaan omalla vastuullamme tuotteen yhtenäkkäisäus:</p> <p>Reference / Referencia / Referência / Référence / Articolo / Artikelnummer / Αριθμός / Referens / Referensi: <b>4513XX</b></p> <p>Description / Descripción / Descrição / Description / Descrizione / Beschreibung / Περιγραφή / Beskrivning / Kavaus: <b>CATV Outdoor amplifier</b></p> <p>Trademark / Marca / Marca / Marque / Marchio / Handelsmarke / Máarka / Varumärke / Tavaranmerkki: <b>Televés</b></p> <p>With the requirements of / Con los requerimientos de / Com as especificações de / Avec les conditions de / Con i requisiti di / Die Voraussetzungen erfüllen / Με τις απαιτήσεις του / Enligt följande bestämmelser / Seuraavien määräysten:</p> <p>- Low Voltage Directive 2006 / 95 / EC.                  - EMC Directive 2004 / 108 / EC.</p> <p>Following standards / Con las normas / Com as normas / Selon les normes / Con le norme / Folgende Anforderung / Ακόλουθα πρότυπα / Följande standard / Seuraavien standardien:</p> <p>EN 60065:2002 + A1:2006 + A11:2008 - Audio, video and similar electronic apparatus - Safety requirements.                  EN 60728-11:2005 - Cable networks for television signals, sound signals and interactive services. Part 11: Safety.                  EN 50083-2:2006 - Cable networks for television signals, sound signals and interactive services. Part 2: Electromagnetic compatibility for equipment.</p> <p style="text-align: center;">Santiago de Compostela, 10/2/2011</p> <div style="text-align: center;">                   José L. Fernández Carnero                  Technical Director             </div>	



# RED COMERCIAL - COMMERCIAL NETWORK

**UNITED KINGDOM**  
TELEVES (UK) Ltd.  
11 Hill Street Industrial Estate  
Cwmbran, Gwent NP44 7PG  
UNITED KINGDOM  
Telephone: +44 1633 875821  
Fax: +44 1633 866311  
EMail: televes.uk@televes.com

**FRANCE**  
TELEVES FRANCE Sarl  
1 Rue Louis de Broglie  
Parc d'Activités de l'Esplanade  
77400 St. Thibault des Vignes  
FRANCE  
Telephone: +33 1 6035 9210  
Fax: +33 1 6035 9040  
EMail: televes.fr@televes.com

**POLSKA**  
TELEVES POLSKA Sp. z o.o.  
Ul. Bardzka 60  
50-517 Wrocław  
Telephone: +48 71 7901 115  
Fax: +48 71 7901 112  
EMail: televes.pl@televes.com

**GERMANY**  
TELEVES DEUTSCHLAND GmbH  
An den Kiesgruben 6, 73240 Wendlingen  
DEUTSCHLAND  
Telephone: +49 7024 55358  
Fax: +49 7024 6295  
EMail: televes.de@televes.com

**USA**  
TELEVES USALLC.  
9800 Mount Pyramid Court, Suite 400  
80112 Englewood, CO  
USA  
Telephone: +1 303 256 6767  
Fax: +1 303 256 6769  
EMail: televes.usa@televes.com

**CHINA**  
TELEVES CHINA  
Unit 207-208, Building A, No 374  
Wukang Rd, Xuhui District  
200031 Shanghai  
CHINA (P.R.C.)  
Telephone: +86 21 6126 7620  
Fax: +86 21 6466 6431  
EMail: shanghai@televes.net.cn

**PORTUGAL**  
TELEVES ELECTRONICA PORTUGUESA  
Via Dr. Francisco Sa Carneiro, Lote 17  
Zona Ind. Maia 1 Sector X  
4470 Barca-Maia-Porto  
PORTUGAL  
Telephone: +351 22 94 78900  
Fax: +351 22 94 78900  
EMail: televes.pt@televes.com

**ITALY**  
TELEVES ITALIA Srl.  
Via Liguria 24  
2068 Peschiera Borromeo (MI)  
ITALIA  
Telephone: +39 02 5165 0604  
Fax: +39 02 5530 7363  
EMail: televes.it@televes.com

**MIDDLEEAST**  
TELEVES MIDDLE EAST FZE  
PO. Box 17199 Jebel Ali Free Zone  
Dubai  
UNITED ARAB EMIRATES  
Telephone: +971 48 834 344  
Fax: +971 48 834 644  
EMail: televes.me@televes.com

- \* Oficinas Centrales / Head Office
- Delegaciones / Subsidiaries

## Sucursales / Distributors

Para conocer nuestra red de sucursales en el mundo, le rogamos consulte en nuestra pagina web  
Please visit Televes web site to find your nearest Official Distributor

# Televes®

Rúa Benéfica de Conxo, 17  
15706 - Santiago de Compostela  
ESPAÑA (SPAIN)

Tel: +34 981 52 22 00 - Fax: +34 981 52 22 62  
televes@televes.com - www.televes.com



0103082-012

