

Product Dimensions:

[www.balancebox.eu](http://www.balancebox.eu)

**Compatible with:**

- BalanceBox® 400
- BalanceBox® 400H

Compatibility with BalanceBox® tilt is limited, please refer to our product warnings sheet.

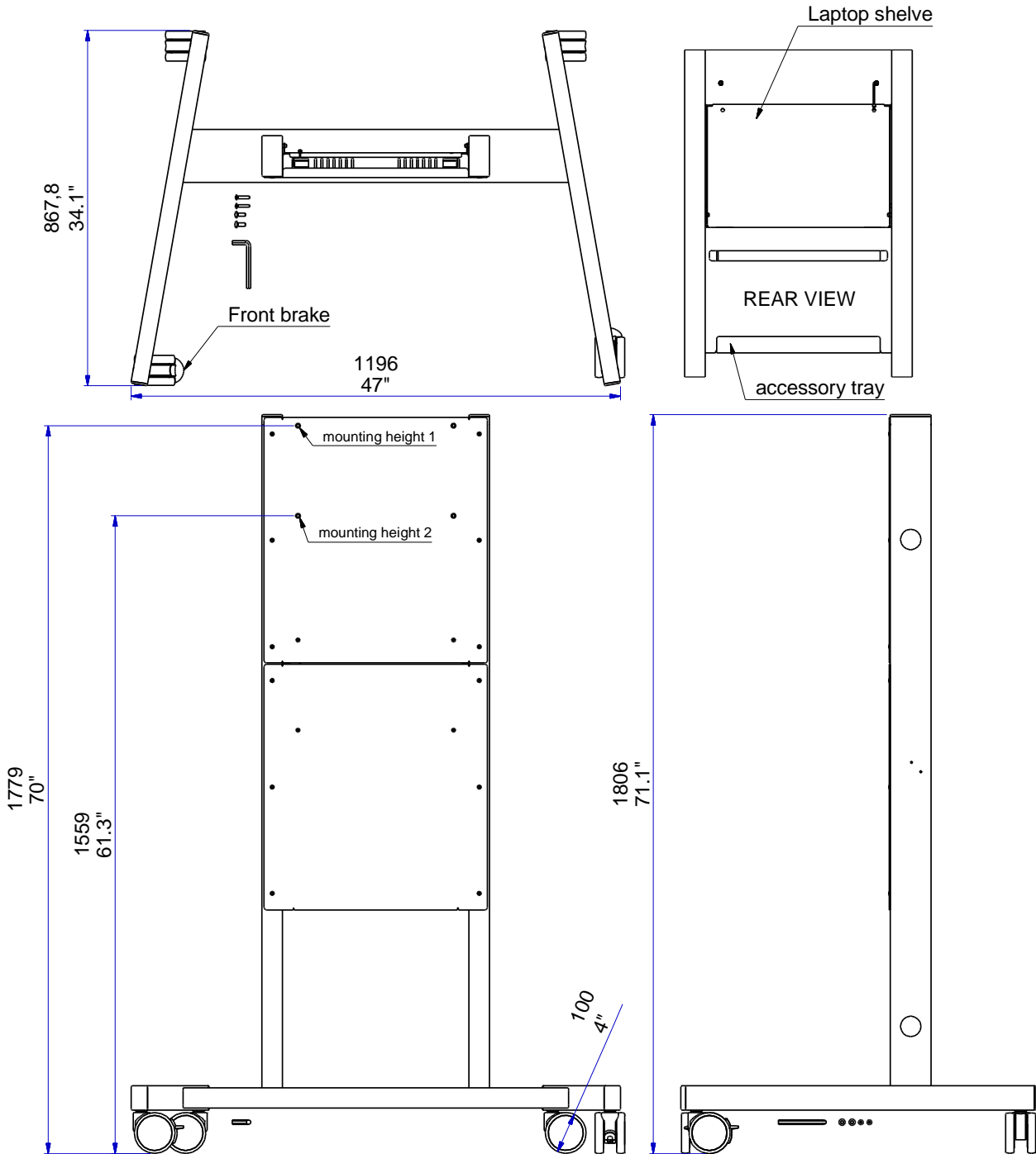

V:20160921





# Mobile stand LWB for the BalanceBox® 400

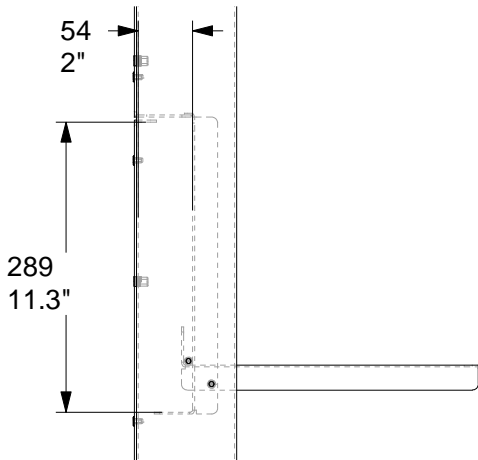

Integrated laptop shelf, can be closed with a padlock in up position (padlock not included) for mini computer or laptop.

	Product Specifications 481A47002 Mobile stand for BalanceBox® 400		Shipping dimensions	
	metric value	metric units	US / imperial value	US / imperial units
<b>Length</b>	1806 mm		71.1 inch	
<b>Width</b>	1196 mm		47 inch	
<b>Depth</b>	868 mm		34.1 inch	
			47 kg	103.4 lbs
<b>Wheel diameter</b>	100 mm		4 inch	
<b>Load capacity</b>	125 Kg		209 Lbs	
<b>Material</b>	Steel frame			
<b>Finish</b>	Powder coated in colour: Black RAL9005			

- For BalanceBox 400 for touchpanels 55" to 70"
- Use only with BalanceBox accessories
- Use with BalanceBox® Tilt is limited, please refer to our warnings datasheet
- 50mm / 2" holes in frame for cable ducting
- Integrated laptop shelf doubles as lockable mini computer or laptop enclosure (padlock not included)
- 100 mm / 4" black nylon wheels with non marking PU tires
- Product certification: CE and UL recognized component



205 Westwood Ave, Long Branch, NJ 07740  
 Phone: 866-94 BOARDS (26273) / (732)-222-1511  
 Fax: (732)-222-7088 | E-mail: sales@touchboards.com

The information in this leaflet can be subject to changes.