

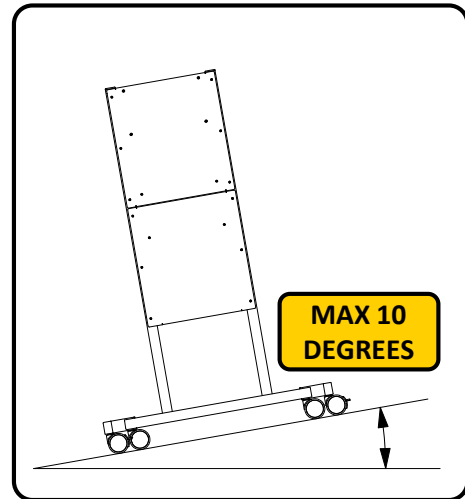

# MOBILE STAND LWB for the BalanceBox® 400 and 400H

# MOBILE STAND LWB for the BalanceBox® 400 and 400H Installation manual



WARNING MAXIMUM SLOPE

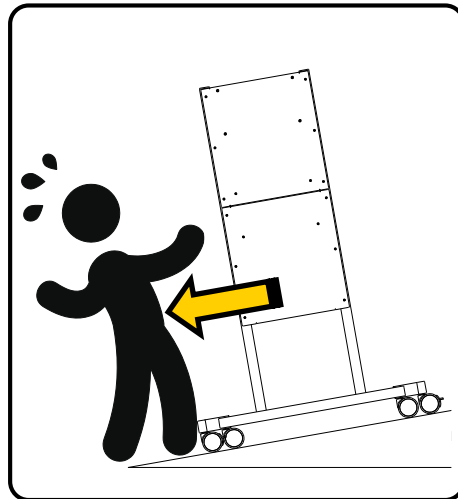

WARNING DO NOT PULL DOWN SLOPE

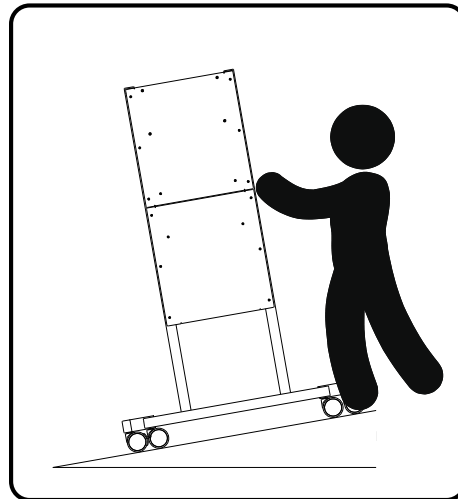

STAY ABOVE CART WHEN MOVING DOWN SLOPE



CAUTION

This cart is intended for use with a BalanceBox® height adjustable mount and flat screen or touchscreen TV or Interactive whiteboard weighing not more than:

**200 pounds (90 kg).**

Use with other products may result in instability causing possible injury.



CAUTION

“This cart is intended for use only with the maximum weights indicated. Use with products heavier than the maximum weights indicated may result in instability causing possible injury.”



205 Westwood Ave, Long Branch, NJ 07740  
Phone: 866-94 BOARDS (26273) / (732)-222-1511  
Fax: (732)-222-7088 | E-mail: sales@touchboards.com

The information in this leaflet can be subject to changes.

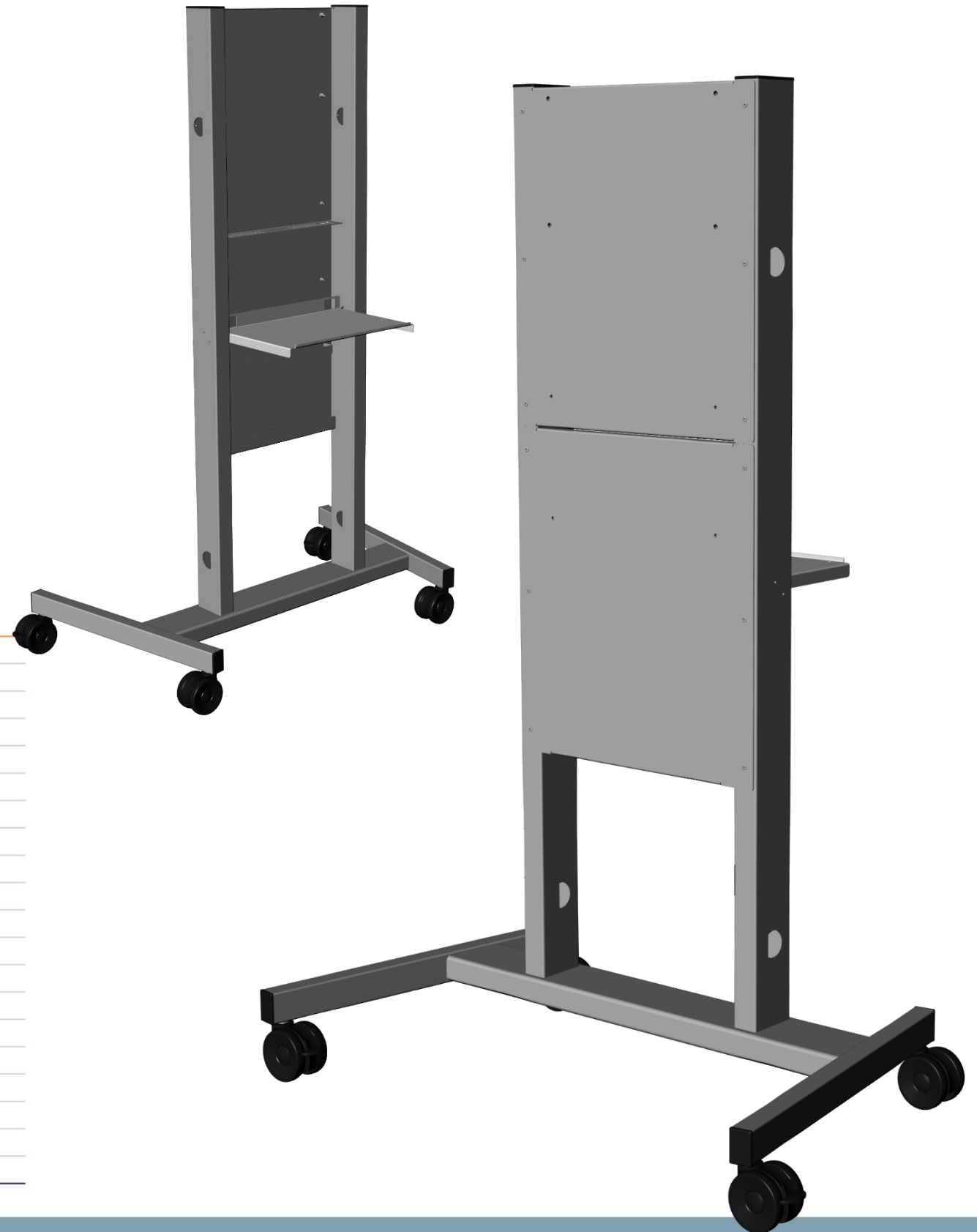

partnr: 902831-00



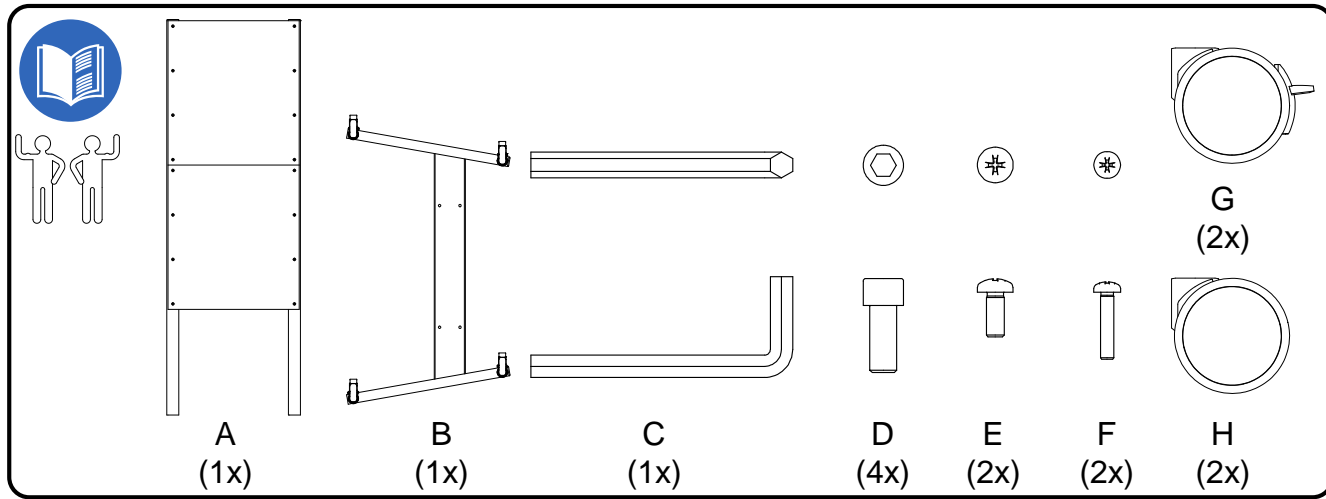

Contents of the box

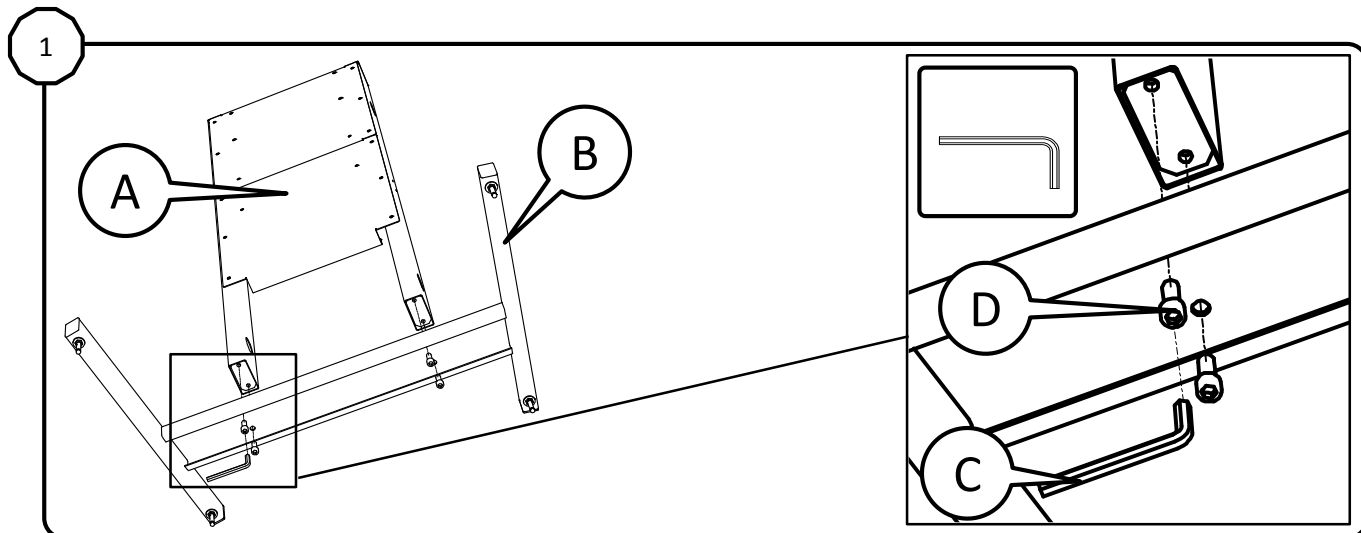

Assemble (● 10 mm)

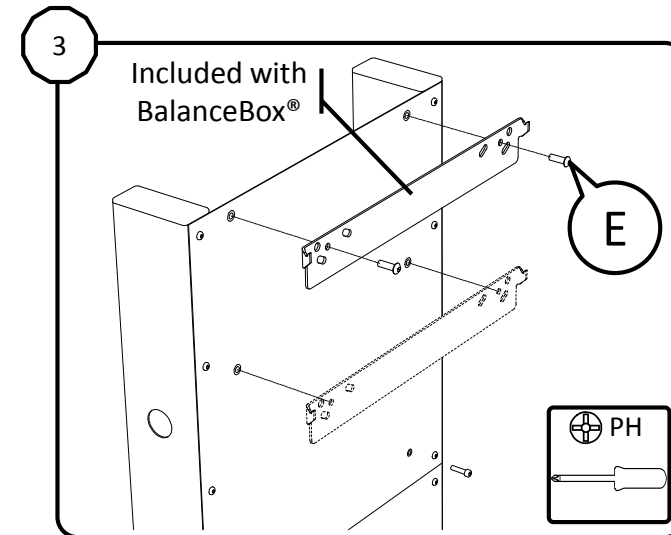
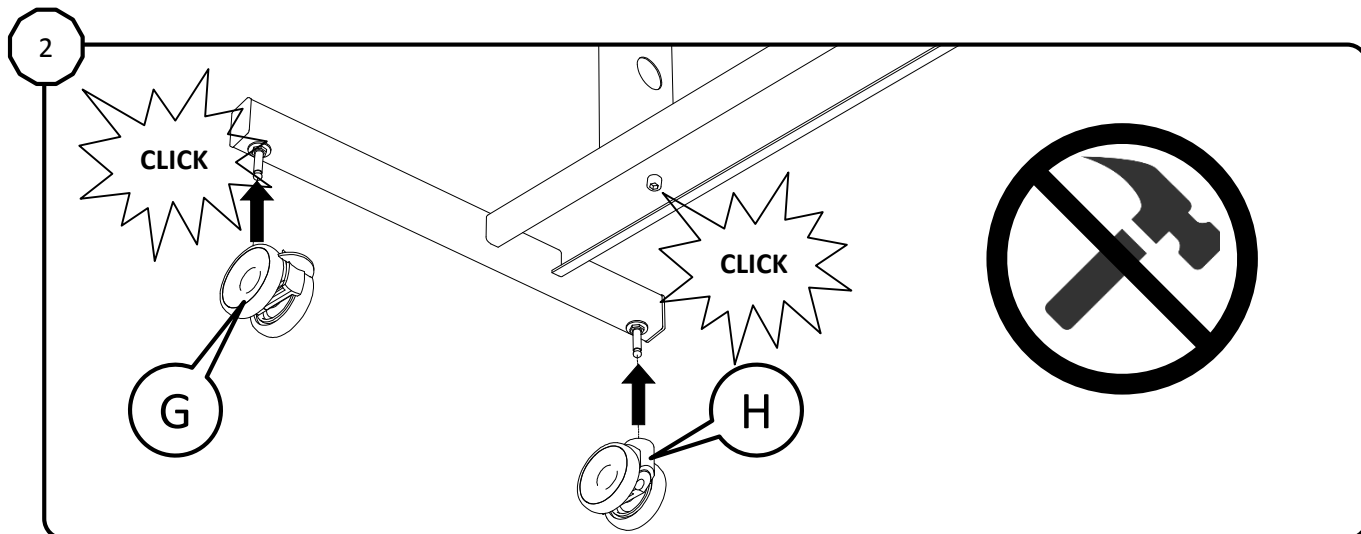

Mount the BalanceBox® bracket  
( 2 options for mounting height)

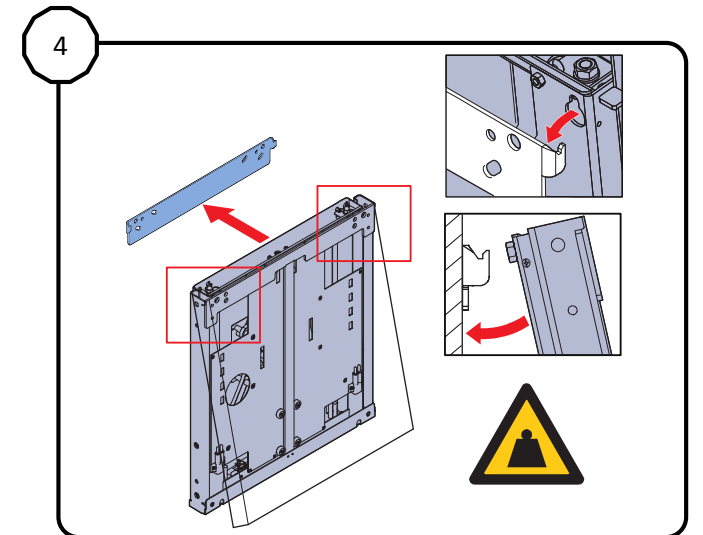

Please refer to BalanceBox® user manual!

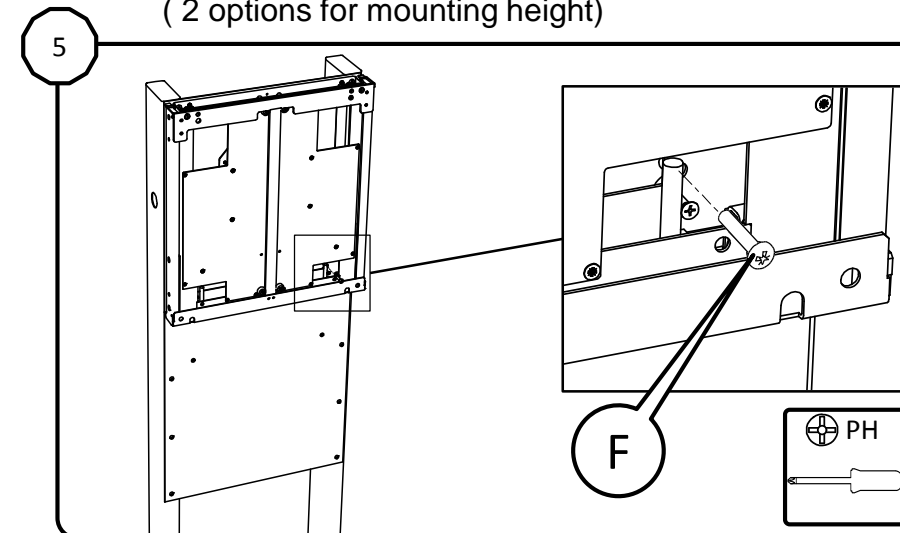

Lock BalanceBox® with safety screws at the bottom

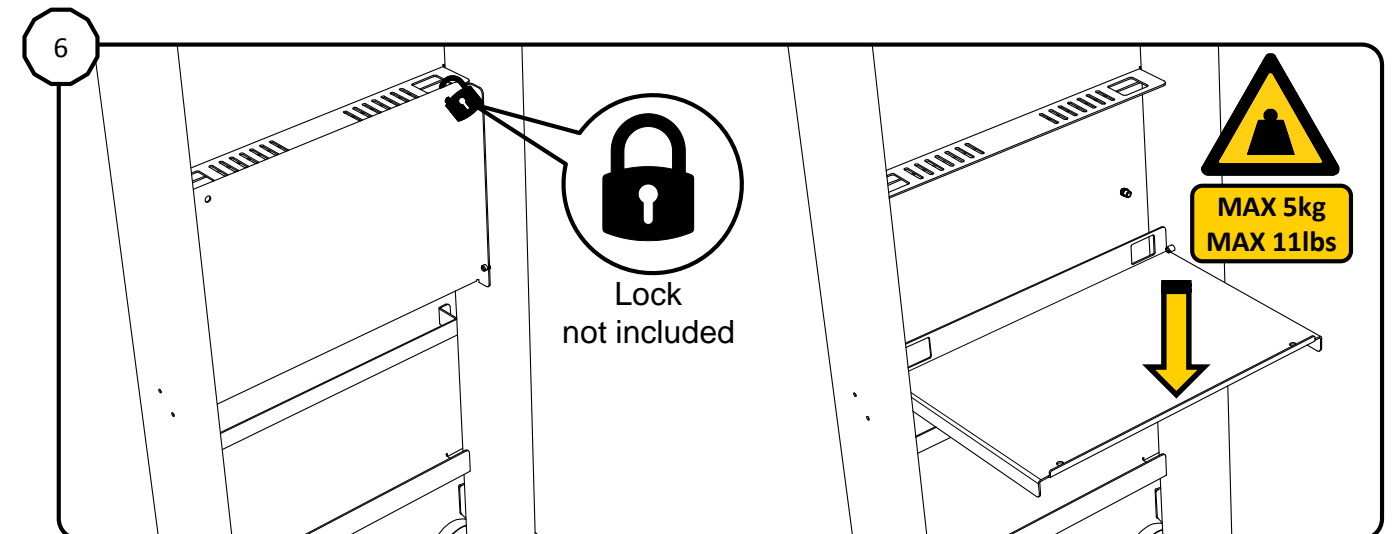

**Touchboards**

205 Westwood Ave, Long Branch, NJ 07740  
Phone: 866-94 BOARDS (26273) / (732)-222-1511  
Fax: (732)-222-7088 | E-mail: sales@touchboards.com