

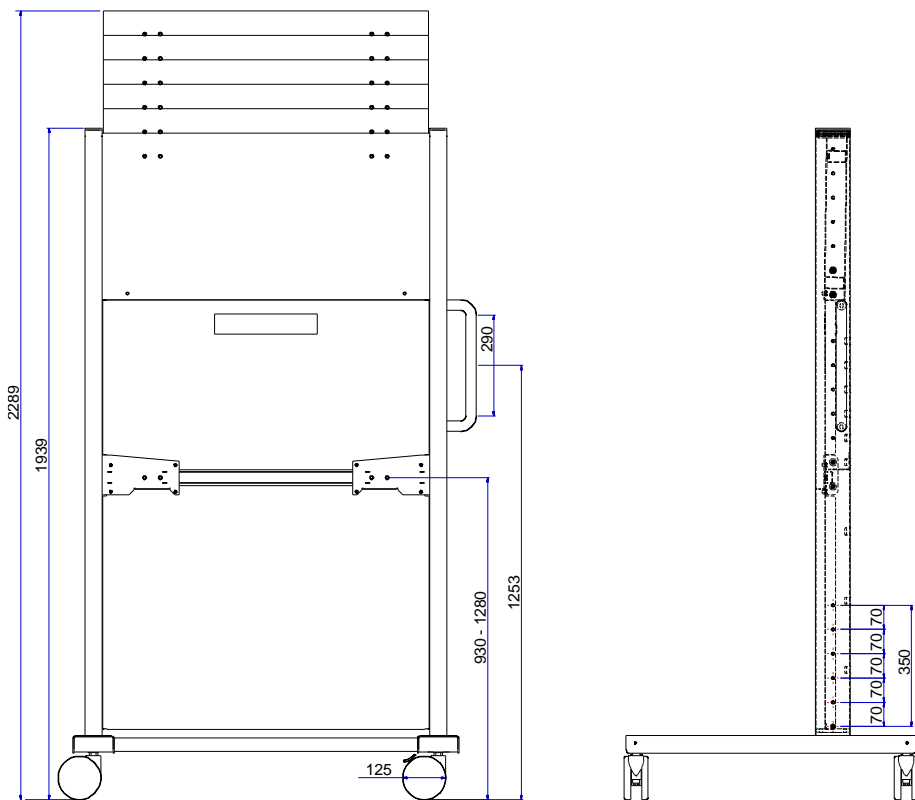

205 Westwood Ave, Long Branch, NJ 07740
Phone: 866-94 BOARDS (26273) / (732)-222-1511
Fax: (732)-222-7088 | E-mail: sales@touchboards.com

Product dimensions:

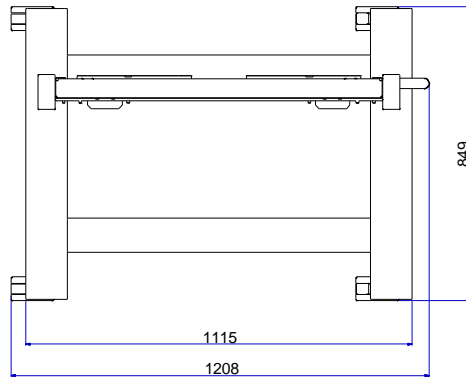

Weights & dimensions	Length	Width	Height	Weight kg	Length	Width	Height	Weight lbs
	mm	mm	mm		inch	inch	inch	
Shipping dimensions	1900	1200	300	100	74.8	47.25	12	220
Product dimensions	1208	849	1939-2289	72	47.5	33.4	76.3 – 90.1	168
Material / colour	Steel frame and covers, powder coated for corrosion resistance colour RAL9007 (grey aluminium)							

V:20160316





BalanceBox® 650 Mobile Stand

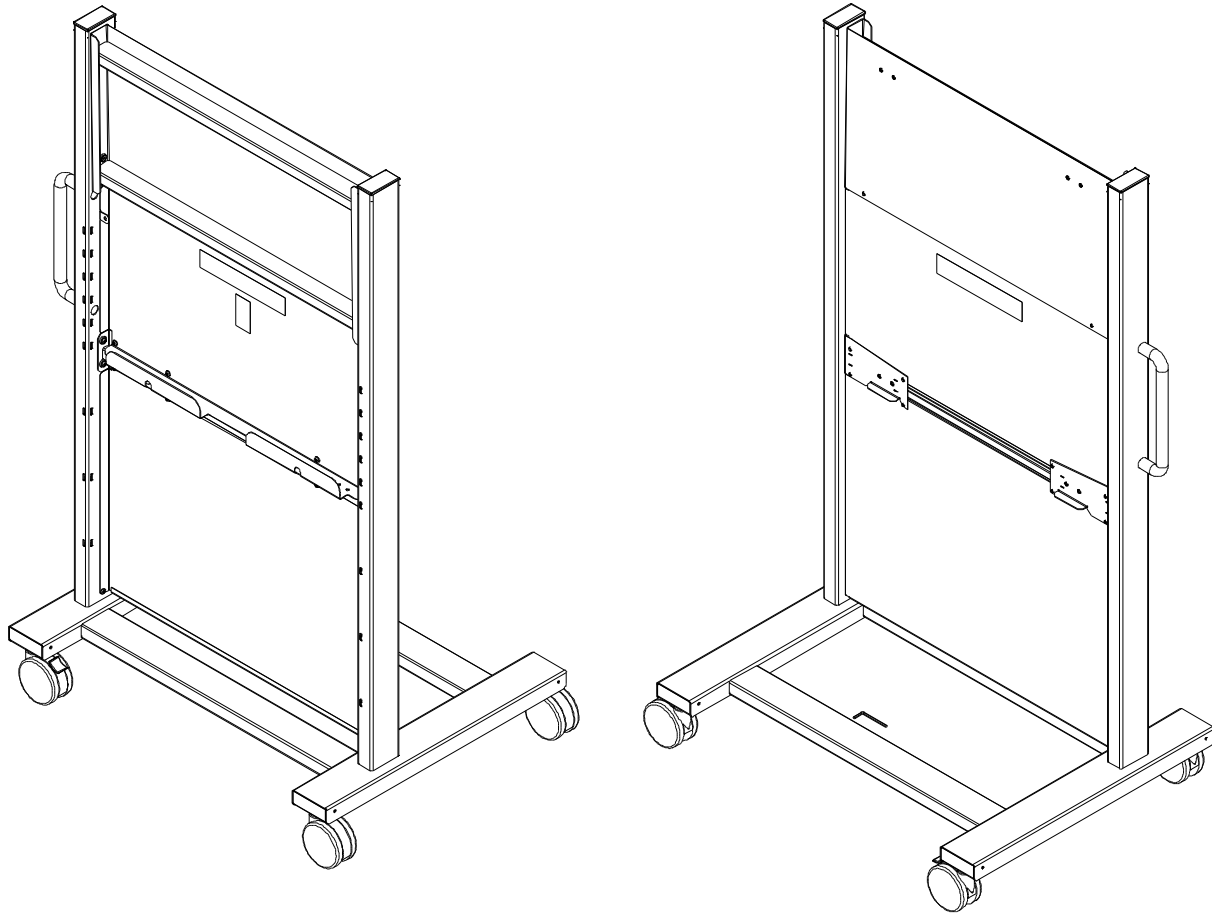

Included in the package:

- BalanceBox® 650 Mobile Stand and multi-language manual
- Assembly by installer or customer, 2-piece frame and wheels

Product features:

- Steel frame powder coated black RAL9005, centre part can be set in height at assembly in five 70 mm (2.75") intervals
- 125mm (5") rubber non-marking wheels, 2 fixed, 2 pivoting. Brake on pivoting wheels.
- Large handle for safe and easy operation
- Holes in the back frame for cable management
- UL recognized
- CE certified

Compatible with BalanceBox® 650 product range and panels weighing up to 180kg / 396 lbs

Optional – Foldable and lockable computer tray for assembly on the back part number 481A51.

Touchboards

205 Westwood Ave, Long Branch, NJ 07740
Phone: 866-94 BOARDS (26273) / (732)-222-1511
Fax: (732)-222-7088 | E-mail: sales@touchboards.com

The information in this leaflet can be subject to changes.