

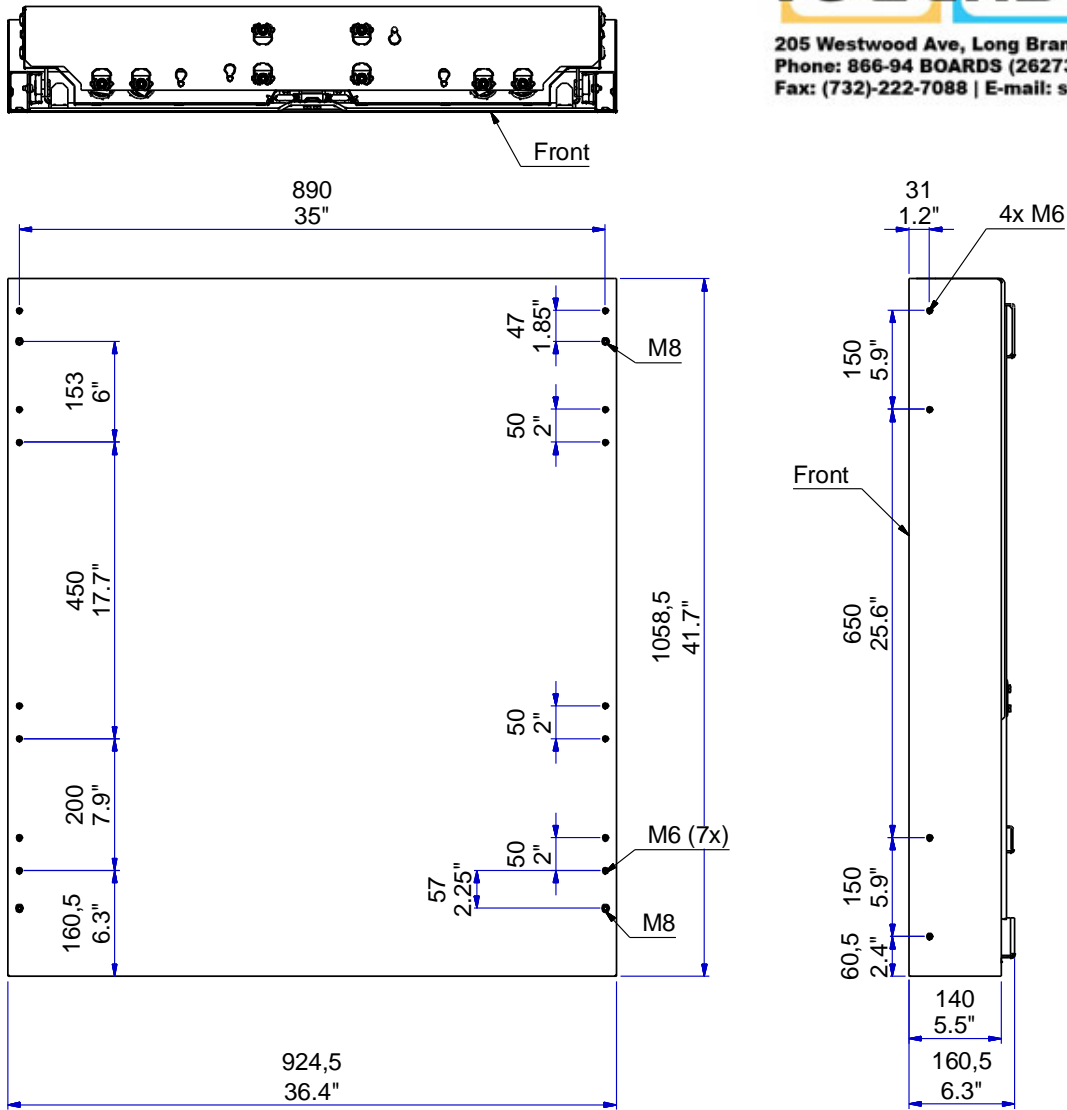

205 Westwood Ave, Long Branch, NJ 07740
Phone: 866-94 BOARDS (26273) / (732)-222-1511
Fax: (732)-222-7088 | E-mail: sales@touchboards.com

Product dimensions:



Weights & dimensions	Width mm	Height mm	Depth mm	Weight kg	Width inch	Height inch	Depth inch	Weight lbs
Shipping dimensions	1005	1155	240	75	39.6	45.5	9.4	165
Product dimensions	924,5	1058,5	160,5	58	36.4	41.7	6.3	127.6
Material / colour	Steel frame and covers, powder coated for corrosion resistance colour RAL7037							

V:20151022



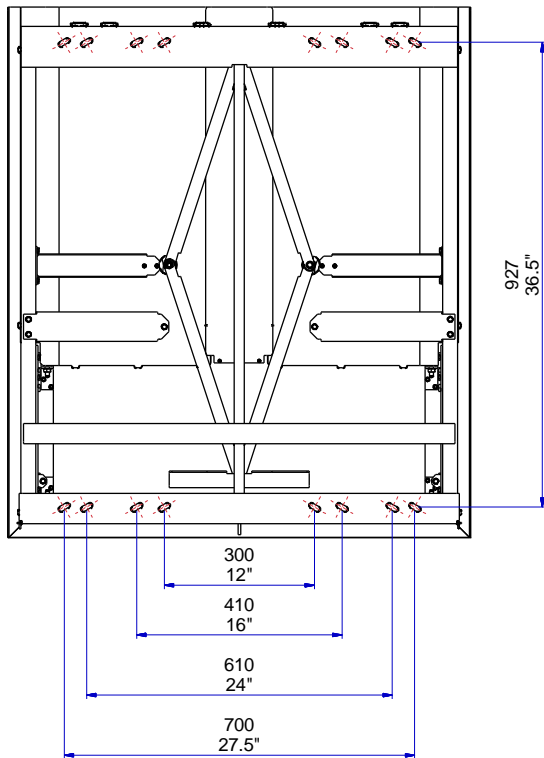

Wall mounting hole dimensions :

10 mm fasteners and wall plugs not included

Included in the package: BalanceBox® 650 and multi-language manual; Wall mounting bracket; Powder coated, steel Wall frame cover and fasteners; steel Application frame cover powder coated.

Not included (required for installation):

13 mm hex socket
Flatscreen mounting interface / VESA bracket for Balancebox 650.

Fasteners for wall mounting (depending on the situation / condition of the wall)

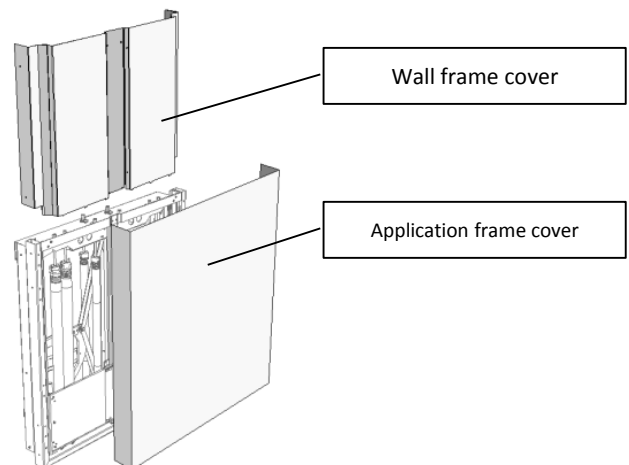

Part numbers

BalanceBox® 650	Description	weight range
484A07	BalanceBox® 650-80 including wall frame and application frame cover	34-70 kg (75-154.3 lbs)
484A08	BalanceBox® 650-130 including wall frame and application frame cover	67-127 kg (147.7-280 lbs)
484A09	BalanceBox® 650-180 including wall frame and application frame cover	94-169 kg (207.2-372.6lbs)
Accessories for Balancebox® 650		product weight
481A19	Balancebox® 650 Flatscreen mounting interface	4,6 kg (10.1 lbs)
481A13	Balancebox® 650 Floor support	12 kg (17.6 lbs)



205 Westwood Ave, Long Branch, NJ 07740
Phone: 866-94 BOARDS (26273) / (732)-222-1511
Fax: (732)-222-7088 | E-mail: sales@touchboards.com

The information in this leaflet can be subject to changes.