

# Assembly Instructions:

To purchase parts or accessories, please contact us at  
[www.spectrumfurniture.com](http://www.spectrumfurniture.com)  
 1-800-235-1262  
 Thank you for choosing Spectrum products!



(8) 026064  
 1/4-20 x 5/8" PHMS



(6) 059872  
 10-32 x 5/8" PH  
 Thread cutting  
 screws

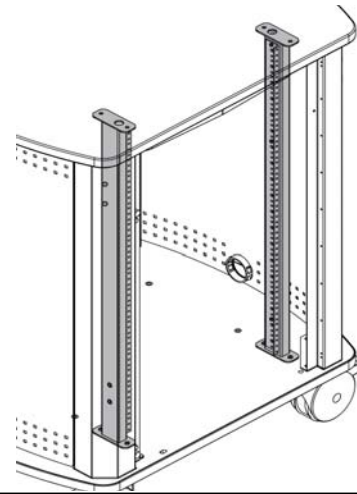

## Optional rack rail kit for LINK

#55134 - for 36" LINK  
 #55139 - for 42" LINK

Before you begin, please make sure all parts and proper quantities are included. Any parts damaged during shipment must be reported within 15 days of receipt. To report information regarding damages or if you have any questions, please call 1-800-235-1262.

**Tools Required:**  
 Phillips screwdriver  
 Electric drill  
 #1 Phillips driver

## 1. Attach rail supports

- Rail supports can be mounted in an outer or inner mounting position.  
*(The inner position can be useful if the rack rail equipment has large knobs or controls- the outer position should be used when maximum equipment depth is necessary.)*
- Position the rail supports as shown. **Figure 1.** *(The 3 pre-drilled holes will face inward.)*
- Attach the supports to the LINK with 1/4-20 x 5/8" PHM screws and tighten securely.

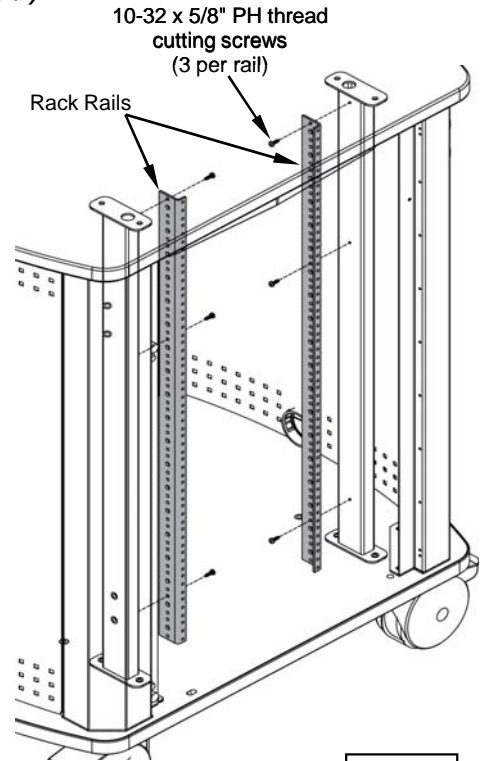
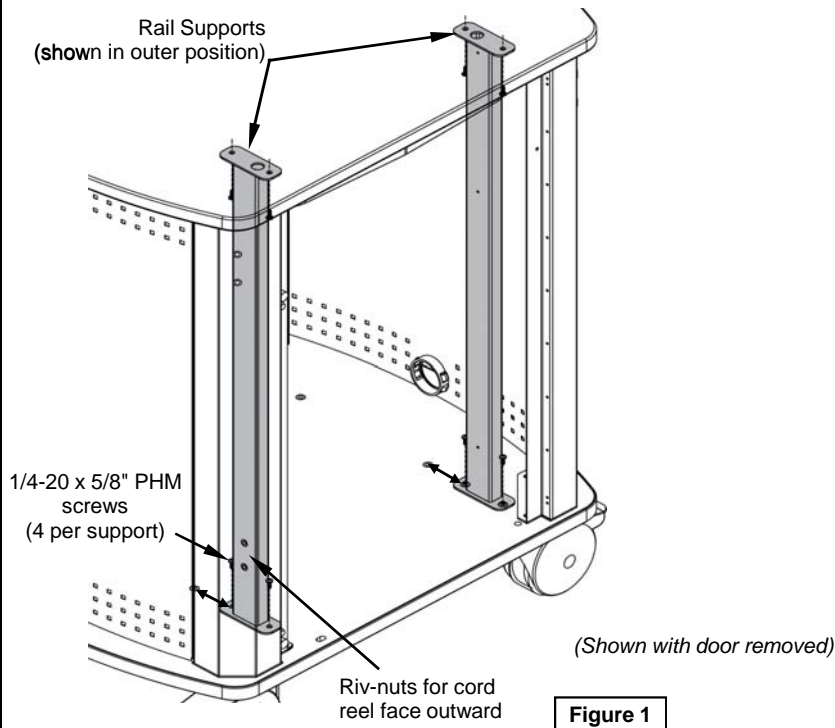

## 2. Attach rack rails

- Position each rack rail with the short leg pointing inward as shown. **Figure 2.**  
 Align the top hole of each rack rail with the top mounting hole in each rail support.
- Using an electric drill with a #1 Phillips driver, attach each rail to the rail support with (3) 10-32 x 5/8" thread cutting screws.  
 Tighten securely, but be careful not to strip out the holes. If equipped, a drill torque setting can help facilitate with attaching the screws.



205 Westwood Ave, Long Branch, NJ 07740  
 Phone: 866-94 BOARDS (26273) / (732)-222-1511  
 Fax: (732)-222-7088 | E-mail: [sales@touchboards.com](mailto:sales@touchboards.com)