

## LINK Lectern with Overbridge Control Console™

55283	36"H LINK Lectern with overbridge
55284	42"H LINK Lectern with overbridge

**Touchboards**

205 Westwood Ave, Long Branch, NJ 07740  
Phone: 866-94 BOARDS (26273) / (732)-222-1511  
Fax: (732)-222-7088 | E-mail: [sales@touchboards.com](mailto:sales@touchboards.com)

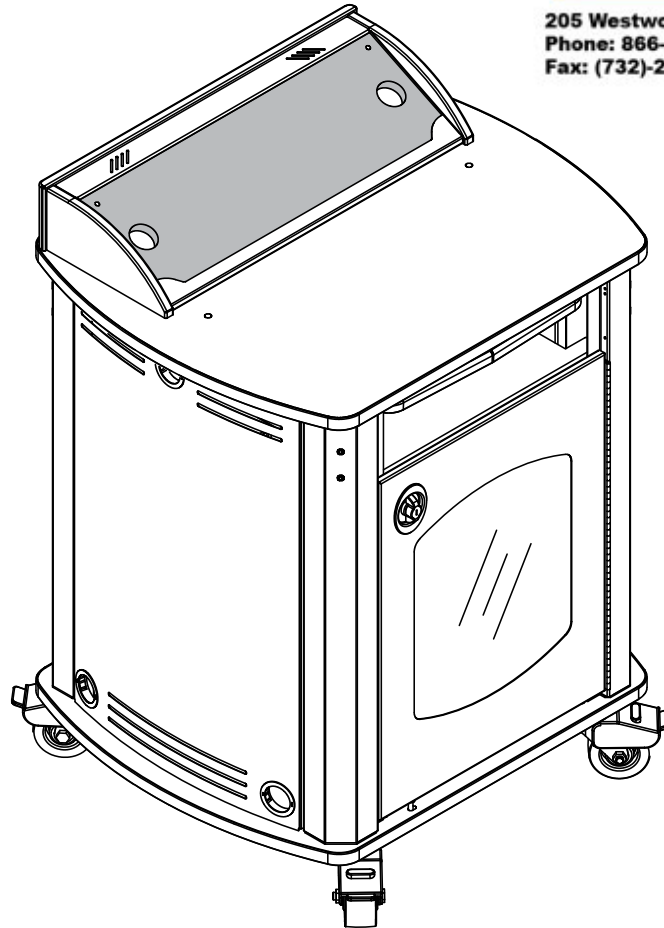

**⚠ Important ⚠**

Before using this product:

- Read this manual
- Comply with all safety and operating instructions
- Ensure all parts and correct quantities are included

Any parts damaged during shipment must be reported within 15 days of receipt. To report information regarding missing parts or damage, to purchase parts or accessories, or if you have any questions, please contact us.

*Thank you for purchasing Spectrum products!*

Spectrum product page:  
<http://bit.ly/LINK-OCC>



Spectrum Industries, Inc  
925 First Avenue, Chippewa Falls, WI 54729 USA  
800 235 1262  
715 723 6750  
[www.spectrumfurniture.com](http://www.spectrumfurniture.com)



## Important Safety and Care Instructions



- Read this owner's manual before assembly or operation.
- Do not allow children to move the lectern.
- Proceed slowly and carefully when moving the lectern.
- For indoor use only. Do not install or store the lectern where it will be exposed to moisture.
- Do not block the ventilation openings.
- Avoid uneven loading of the equipment into the lectern. Uneven weight distribution could cause the lectern to tip when the lectern is moving.
- Do not allow anyone to sit, stand, or climb on the lectern.
- Use a damp, soft-cloth, or sponge, with mild soap or detergent solution to clean dirty surfaces. Do not use harsh solvents or abrasives.
- This lectern is intended for institutional use. It does not have any user-serviceable parts or user-maintenance requirements. If servicing is necessary, please contact Spectrum Industries for assistance.

**Warning** - Relocating audio and/or video equipment to furniture not specifically designed to support audio and/or video equipment may result in death or serious injury due to the furnishing collapsing or over turning onto a child.

**Warning** - Death or serious injury may occur when children climb on audio and/or video equipment furniture. A remote control or toys placed on the furnishing may encourage a child to climb on the furnishing and as a result the furnishing may tip over on to the child.

### Electrical Safety:

- Do not plug the power cord into an extension cord.
- Inspect power cords for damage before each use. Do not use power cords that are damaged.
- Unplug power cord from electrical outlet by gripping the cord. Do not unplug the power cord by pulling only on the cord.
- Do not step on, drive over, drag, or place objects on the power cord.
- For added safety, plug the lectern into a grounded outlet controlled by a GFI (Ground Fault Interrupter) circuit breaker.
- Electrical devices are not toys. Children are often unaware of the hazards associated with electrical devices. This lectern must always be used by adults or with adult supervision.

## Overbridge insert panel

Note: The insert panel shown (*shaded*) is not included with the lectern or overbridge. This option needs to be ordered separately to complete the overbridge.

1. To remove the overbridge insert panel, remove the (2) 1/4-20 x 35mm JC bolts with a 4mm hex wrench and lift out the panel. **Figure 1.**

2. To make cutouts in the insert panel [optional]:

1. Identify all location(s) and sizes for controller(s) or electronics while making sure all devices fit within the maximum cutout space available in the overbridge panel. See **Figure 2-3.**
2. Locate and mark the exact cutout area(s) on the panel. **Note: Using masking tape on cut lines will minimize laminate chipping while cutting.**
3. Carefully make the cutout(s) in the overbridge panel using a jigsaw or router.

3. Install controller(s) / electronics into panel.

4. Re-install the overbridge panel and secure with (2) 1/4-20 x 35mm JC bolts.

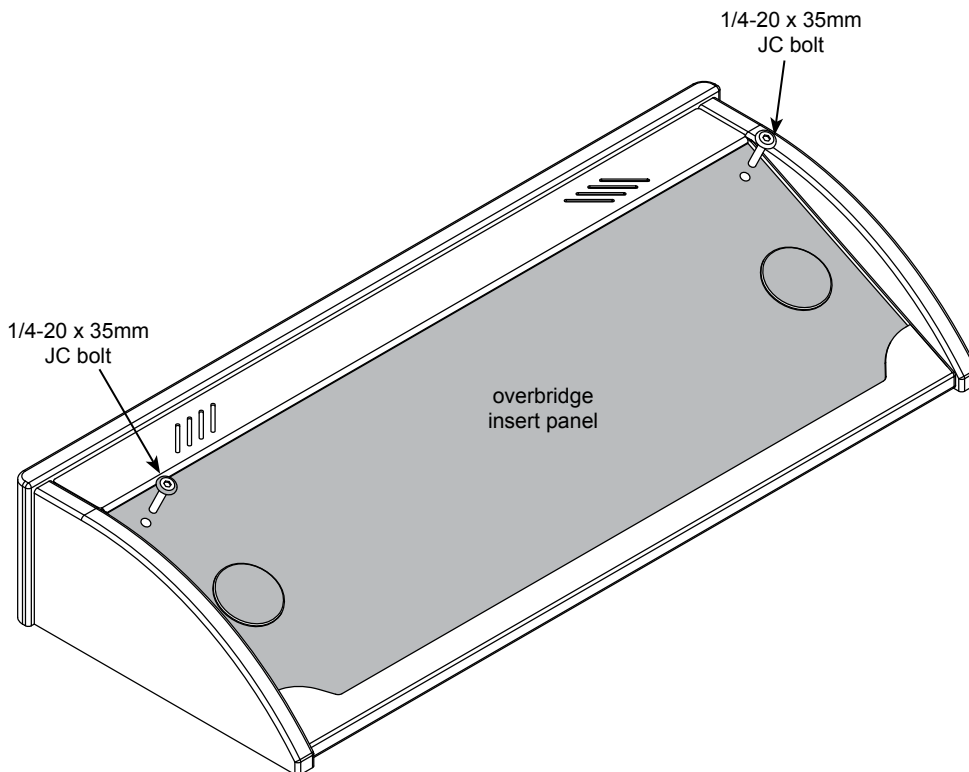
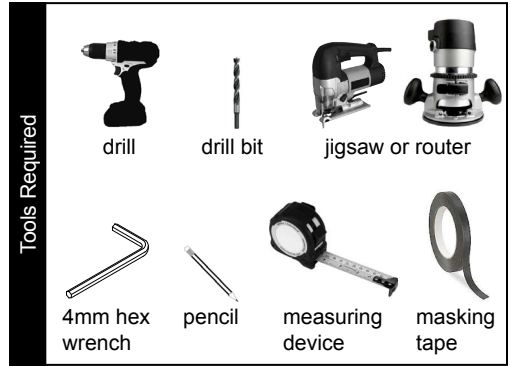

Figure 1

LINK Lectern overbridge panel blank  
(flat view)

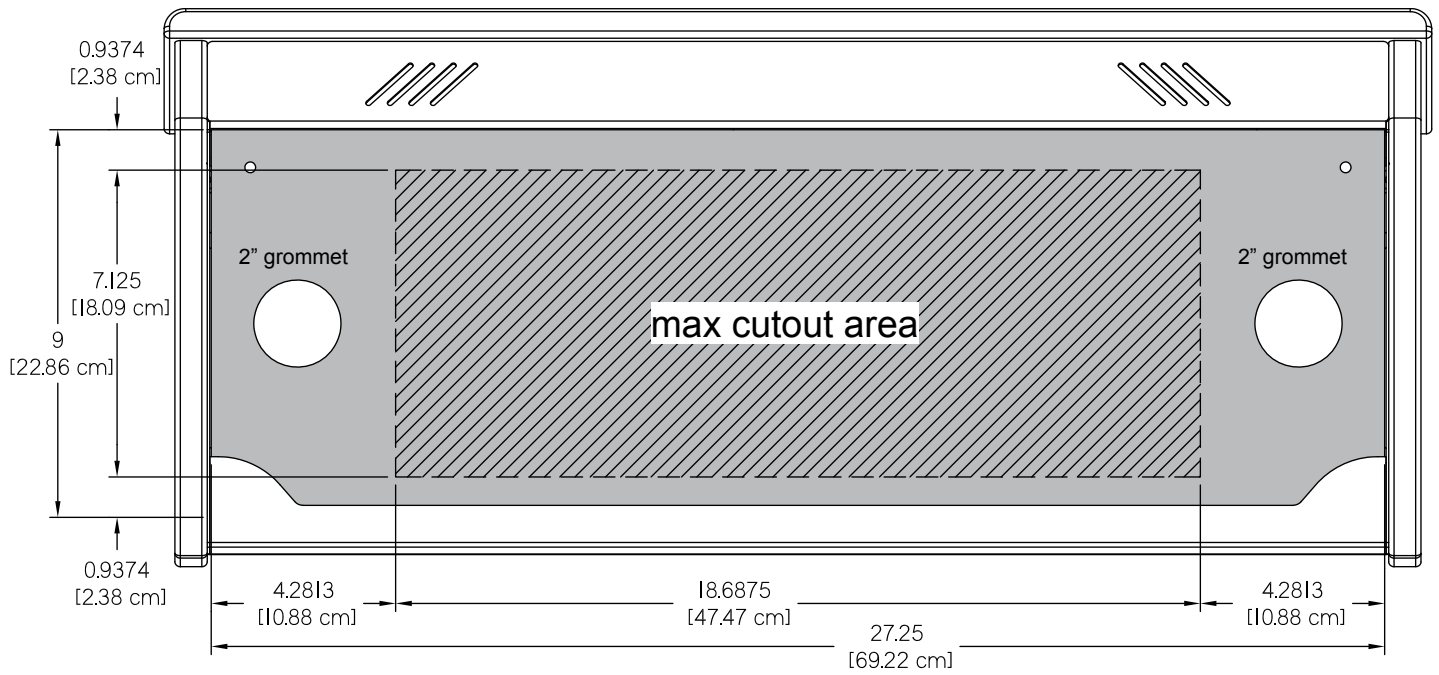
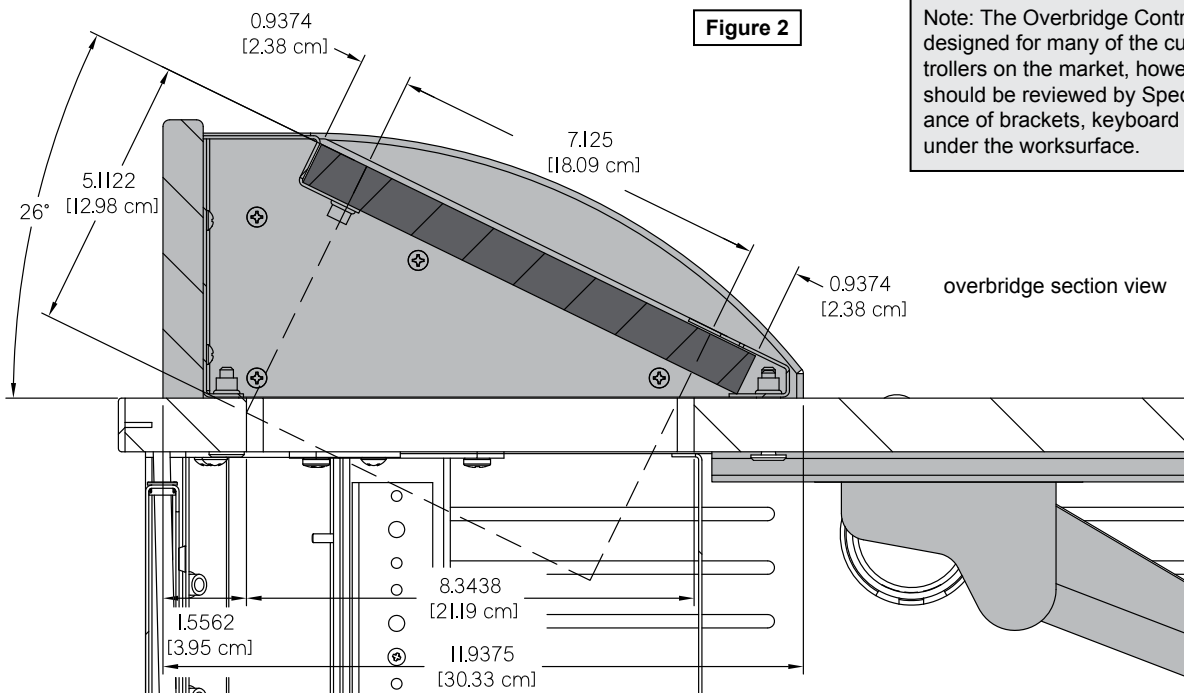

Figure 2

Note: The Overbridge Control Console™ has been designed for many of the currently available controllers on the market, however, modified cutouts should be reviewed by Spectrum to ensure clearance of brackets, keyboard slides, or other objects under the worksurface.



Note: The insert panel shown (*shaded*) is not included with the lectern or overbridge. This option needs to be ordered separately to complete the overbridge. This insert panel is horizontally symmetrical and can be easily removed, rotated, and re-installed if a cutout needs to be relocated to the opposite side of the overbridge.

Figure 3

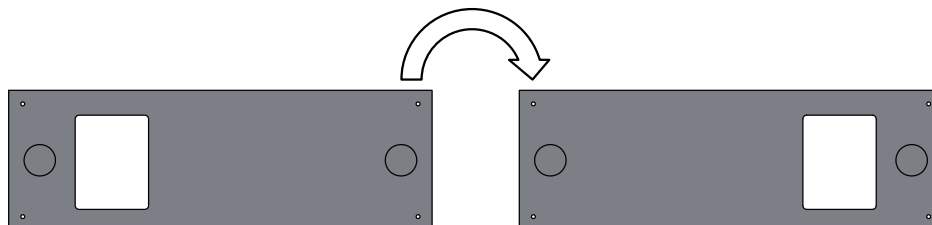

## Floor Anchoring (Toe Kick models only)

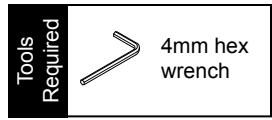

1. If your LINK is equipped with a toe kick, and you wish to attach it to the floor, the toe kick will need to be detached from the lectern. To detach, remove the (4) 1/4-20 x 40mm JC bolts (one on each corner from inside the lectern) with a 4mm hex wrench.
2. Carefully lift the lectern off the toe kick. This will require several people. **Figure 4.**
3. Locate the toe-kick into its final position on the floor and mark the (4) mounting hole locations on the floor (The toe kick mounting holes are 1/2" dia.)
4. Drill holes into your floor and anchor the toe kick with appropriate fasteners.
5. Carefully lift the lectern back onto the anchored toe kick and align the (4) mounting holes.
6. Re-attach the lectern to the toe kick with the (4) previously removed JC bolts.
7. The access panel can be removed to access wiring below lectern.

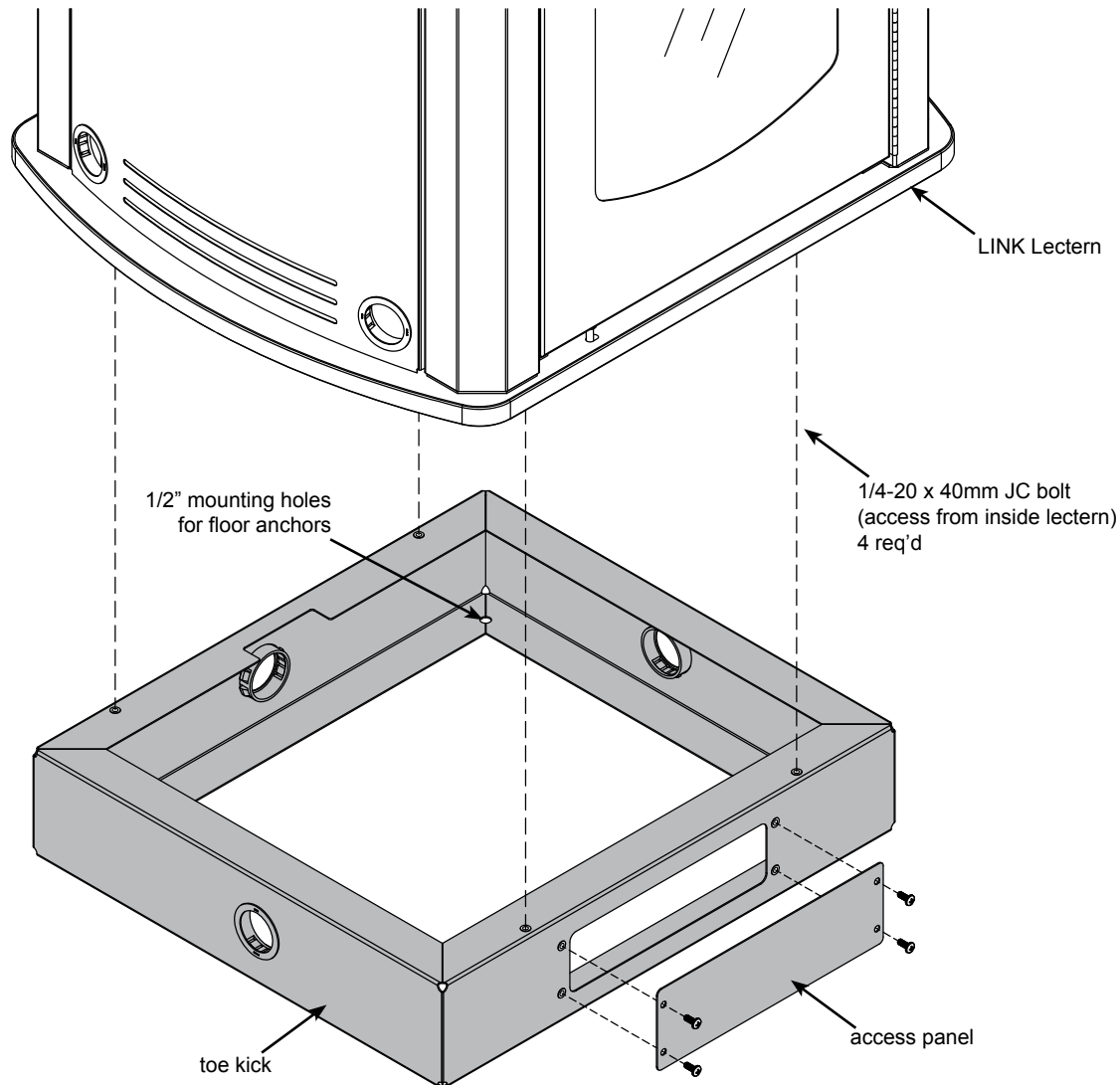
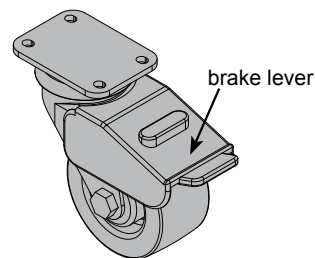

**Figure 4**

Note: 4 fasteners are required to anchor the toe kick to floor. (fasteners not included).

## Wheel operation

1. To lock the wheel rotation, press the brake lever. **Figure 8.**
2. To resume operation, lift up on brake lever.



**Figure 8**

## Moving and parking the lectern

- Before moving, unplug and secure all power cords.
- Close and lock doors.
- Remove any items from the top of the worksurface.
- Unlock the wheels.
- Push slowly and carefully. Do not move over uneven or irregular surfaces.
- Do not allow children to move.
- Lock the wheels after moving.
- Do not park unit in areas of heavy traffic.
- Do not run power cords across hallways, classrooms, or other areas where they will be walked on.
- Do not leave unit unattended in areas where children have access.
- Keep doors closed and locked whenever unit is unattended or parked.
- Keep wheels locked whenever the lectern is unattended.

<p><b>WARNING</b> <b>AVERTISSEMENT</b> <b>ADVERTENCIA</b></p>					
	<p>CAN TIP OVER RESULTING IN RISK OF INJURY, DO NOT ALLOW CHILDREN UNDER 16 TO MOVE CART. MOVE CART SLOWLY.</p>	<p>ONLY ADULTS SHOULD MOVE THIS UNIT</p>	<p>APPLY MOVING FORCE ON NARROW DIMENSION</p>	<p>NEVER APPLY FORCE AT TOP ALWAYS PUSH NEAR MIDDLE</p>	<p>PUSH, DO NOT PULL</p>
	<p>LE MEUBLE POURRAIT SE RENVERSER ET CAUSER DES BLESSURES. NE LAISSER PAS LES ENFANTS DE MOINS DE 16 ANS DÉPLACER CELUI-CI. DÉPLACER LE MEUBLE LENTEMENT.</p>	<p>CE MEUBLE DOIT ÊTRE DÉPLACÉ UNIQUEMENT PAR DES ADULTES.</p>	<p>POUSSER DANS LE SENS DE LA LONGUEUR.</p>	<p>NE JAMAIS EXERCER LA FORCE EN HAUT. POUSSER PRÈS DU MILIEU.</p>	<p>POUSSER, NE PAS TIRER.</p>
<p>PUEDE VOLCARSE Y PROVOCAR LESIONES. NO PERMITA QUE LOS NIÑOS MENORES DE 16 AÑOS MUEVAN EL CARRO. MUEVA EL CARRO LENTAMENTE.</p>	<p>SOLO LOS ADULTOS DEBERÁN MOVER ESTA UNIDAD</p>	<p>APLIQUE LA FUERZA MOTRIZ EN DIMENSIONES ESTRECHAS</p>	<p>JAMÁS APLIQUE FUERZA EN LA PARTE SUPERIOR. SIEMPRE EMPUJE CERCA DE LA PARTE INTERMEDIA</p>	<p>EMPUJE, NO JALE</p>	

0108899

# Options

Note: Flip-up document shelf and steel handle are interchangeable and can be mounted on either side.

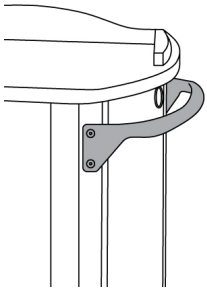

**Steel Handle**  
27.5"W  
55132

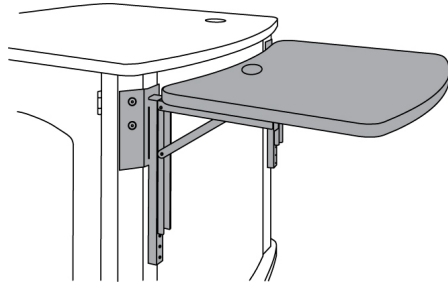

**Flip-up Shelf**  
22.75"W x 26.25"D  
(mounts on left or right side)  
includes 2" grommet, adjustable-height  
(50 lbs max capacity)  
55140

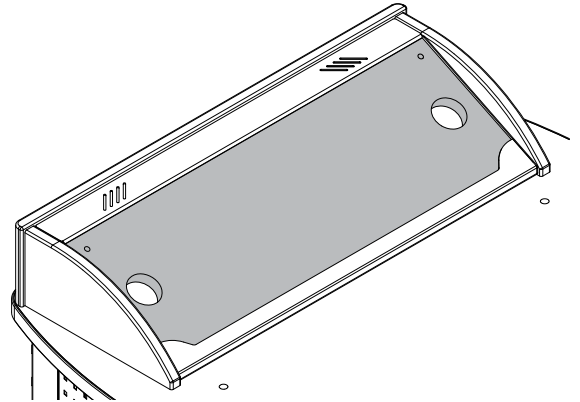

**Overbridge Insert Panel**  
for overbridge version only-contact Spectrum to specify cutout size(s) and position(s)-overbridge not available separately  
(includes two 2" grommets with covers)  
96504 - blank panel  
96504mod - panel with cutout(s)

Note: Power and communication wiring for document cameras, laptop computers, and/or projectors placed on the flip-up shelf should be routed on top of the audience-side of the shelf. Use of the shelf grommet hole for wiring will result in pinching of the cords when the shelf is folded.

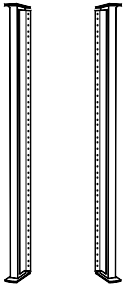

**LINK Lectern Rear Rack Rail Kit**  
55139 - 42" 19RU (15RU full-depth)  
55134 - 36" 15RU (12RU full-depth)

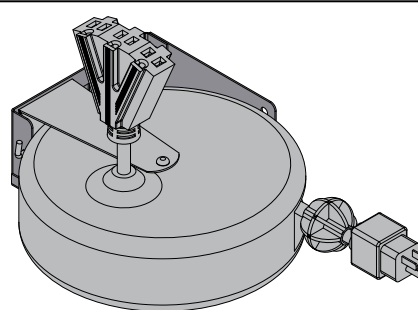

**Universal Cord Reel Kit**  
15' [457.2 cm] retractable, 12 AWG, with breaker, includes universal mounting bracket (mounts horizontally or vertically inside lectern to base panel) 10 lbs [.45 kg]  
99037



Note: When installed, the cord reel takes up rack units from the bottom of the rack rail.

Horizontal installation: 3RU  
Vertical installation: 6RU

**!** The cord reel is intended to provide temporary access to electrical outlets for Spectrum mobile lecterns. Check local electrical codes prior to installation.

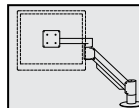

**Flat Panel Monitor Arms and Tablet Mounts**  
(See the Spectrum website or catalog for the latest available monitor arm and tablet mounting options)

# Rack-mount accessories

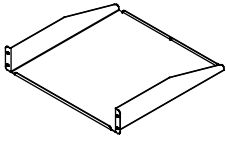

**Cantilever Shelf (2RU)**  
17.5"W x 18"D x 3.5"H  
(50 lbs max load)  
97504

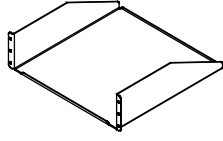

**Cantilever Shelf (3RU)**  
17.5"W x 18"D x 5.25"H  
(80 lbs max load)  
97502

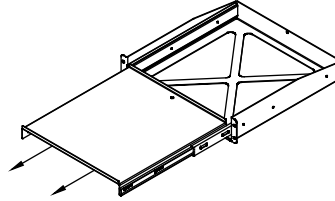

**Pull-Out Shelf (2RU)**  
16.5"W x 17.75"D  
(50 lbs max load)  
97505

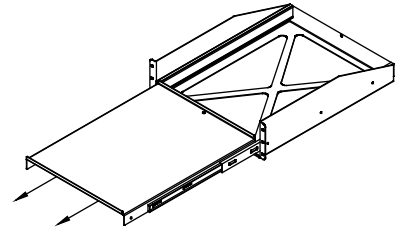

**Pull-Out Shelf (3RU)**  
16.5"W x 21.75"D  
(80 lbs max load)  
97503

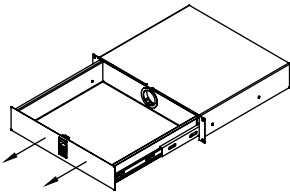

**Locking Drawer (2RU)**  
interior dims:  
15.75"W x 13.6875"D x 2.875"H  
(25 lbs max load)  
97514

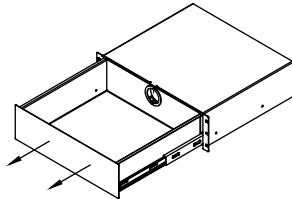

**Drawer (3RU)**  
interior dims:  
15.9375"W x 14.5"D x 5.25"H  
(50 lbs max load)  
97518

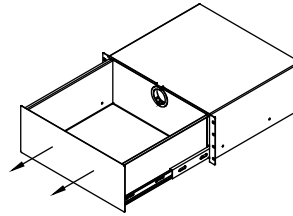

**Drawer (4RU)**  
interior dims:  
15.9375"W x 14.5"D x 7"H  
(50 lbs max load)  
97519

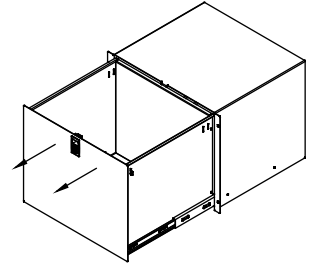

**Locking File Drawer (8RU)**  
with file holder  
interior dims:  
15.75"W x 13.5625"D x  
13.3125"H  
(50 lbs max load)  
97515

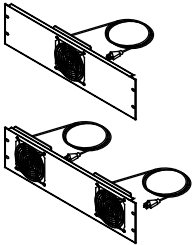

**Cooling Fans (3RU)**  
19"W x 2"D x 5.25"H  
Single Fan-97507  
Double Fan-97506

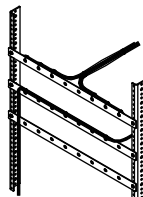

**Wire Lace Kit**  
3 lace straps included  
95517

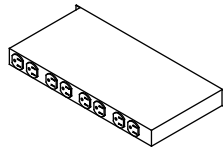

**9-Outlet Power Strip (1RU)**  
19"W x 9"D x 1.75"H  
99021

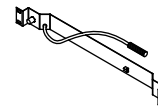

**Flexible Halogen Light (1RU)**  
19"W x 2"D x 1.75"H  
99033

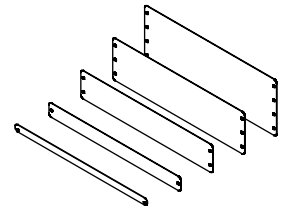

**Rack-Mount Blanks**  
(fills rack spaces where components are not needed)

- 97516 - (½ RU)
- 97510 - (1RU)
- 97511 - (2RU)
- 97512 - (3RU)
- 97513 - (4RU)

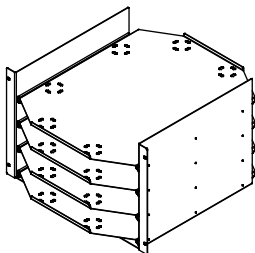

**LT-4 Laptop Storage Unit (7RU)**  
(stores 4 laptops horizontally)  
laptop tray dims:  
16.25"W x 20.5"D x 2.1875"H  
97517



# Warranty

## WE WILL MAKE IT RIGHT FOR YOU!

Spectrum is committed to provide complete customer satisfaction. Each of our products is manufactured from the best materials available and each product is stringently monitored throughout the production process through our P.A.C.E. program (Product Assurance to meet Customer Expectations).

We expressly warrant that Spectrum products will be of good quality and workmanship and free from defect for the period set out in the warranty table below from the date of delivery. This warranty shall not apply to defects or damage resulting from misuse, abuse, neglect, improper care, modification or repair not authorized by Spectrum, or any other cause outside the control of Spectrum. Spectrum will, at its sole option, either repair or replace the defective product.

This warranty is exclusive; no other warranty, written or oral, is expressed or implied. This warranty is given by Spectrum to Buyer and to no other person or legal entity. No Spectrum dealer, distributor, agent or employee is authorized to make any modification or addition to this warranty.

**NOTWITHSTANDING ANYTHING TO THE CONTRARY, SPECTRUM WILL NOT UNDER ANY CIRCUMSTANCES BE LIABLE FOR INDIRECT OR LIQUIDATED DAMAGES, INCLUDING CONSEQUENTIAL, INCIDENTAL AND SPECIAL DAMAGES. IN NO EVENT SHALL SPECTRUM'S LIABILITY, WHETHER UNDER CONTRACT OR WARRANTY, IN TORT OR OTHERWISE, EXCEED THE PURCHASE PRICE RECEIVED BY SPECTRUM FOR THE PRODUCT AT ISSUE AND "RECALL ACTION" EXPENSES. SPECTRUM SHALL NOT BE SUBJECT TO ANY OTHER OBLIGATIONS OR LIABILITIES, WHETHER ARISING OUT OF BREACH OF CONTRACT, WARRANTY, TORT (INCLUDING NEGLIGENCE AND STRICT LIABILITY) OR OTHER THEORIES OF LAW, WITH RESPECT TO PRODUCTS SOLD OR SERVICES RENDERED BY SPECTRUM, OR ANY UNDERTAKINGS, ACTS OR OMISSIONS RELATING THERETO.**

Our Customer Service Department is ready to provide immediate attention to any questions, comments or concerns. They are available to answer your calls Monday through Friday from 7 am to 5 pm CST. In addition your product comments or concerns are welcome via e-mail at: [spectrum@spectrumfurniture.com](mailto:spectrum@spectrumfurniture.com).

Warranty Table

Item	Warranty Period
<ul style="list-style-type: none"> <li>• Adjustable Crank/Electric Desk Legs</li> <li>• Flat Panel Desk Gas Cylinders</li> </ul>	<ul style="list-style-type: none"> <li>• 1 Year</li> </ul>
<ul style="list-style-type: none"> <li>• Adjustable Height Chair Parts – including frames, gas cylinders, wood and plastic parts, and control handles Adjustable Height Chair Parts Casters</li> <li>• Adjustable Height Chair Upholstery</li> <li>• In-Stock Upholstery</li> <li>• Graded-In Fabrics and Customer Owned Material</li> </ul>	<ul style="list-style-type: none"> <li>• 7 Years</li> <li>• 2 Years</li> <li>• 2 Years</li> <li>• No Warranty</li> </ul>
<ul style="list-style-type: none"> <li>• Height Adjustable Columns and Lifts</li> <li>• General Use Casters</li> <li>• Electrical</li> <li>• Keyboard/Mouse Trays</li> </ul>	<ul style="list-style-type: none"> <li>• 1 Year</li> </ul>
<ul style="list-style-type: none"> <li>• Flat Panel Monitor Arm – General Parts</li> <li>• Flat Panel Monitor Arm – Gas Cylinders</li> </ul>	<ul style="list-style-type: none"> <li>• 5 Years</li> <li>• 2 Years</li> </ul>
<ul style="list-style-type: none"> <li>• Computer Desk Chassis</li> <li>• Cart Chassis</li> <li>• Lectern Chassis</li> </ul>	<ul style="list-style-type: none"> <li>• 10 Years</li> </ul>

