

Technical Specifications

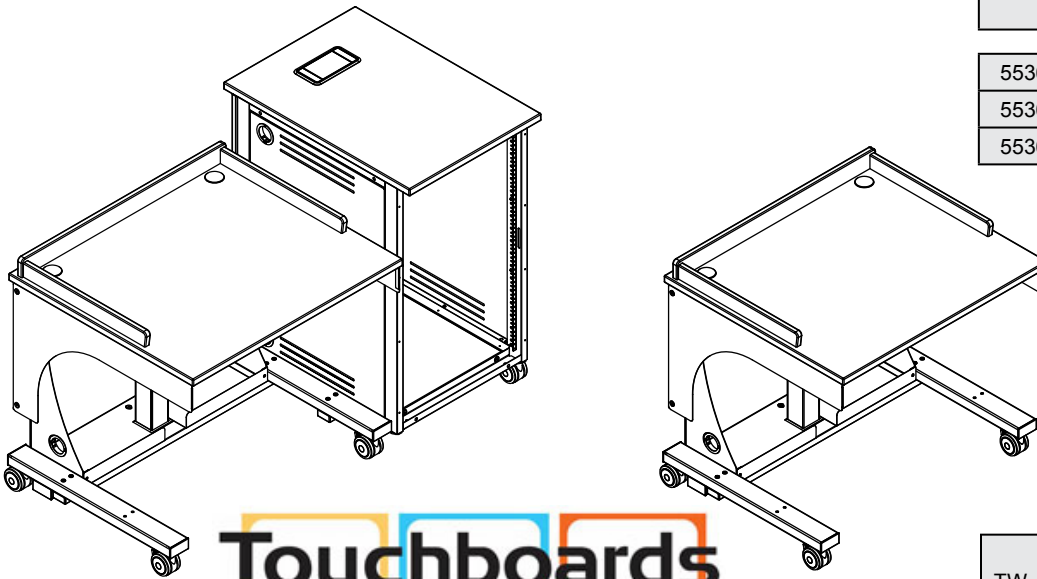

205 Westwood Ave, Long Branch, NJ 07740
Phone: 866-94 BOARDS (26273) / (732)-222-1511
Fax: (732)-222-7088 | E-mail: sales@touchboards.com

Use the Freedom One Sit-to-Stand Lectern where worksurface height adjustment or ADA compliance is required and rack rail for equipment storage is required. The lectern can have either glides or casters installed for stationary or mobile use. Manually adjust the worksurface height from 30-42" (with casters) with a pneumatic-gas assisted spring. The worksurface has a lift capacity of 38 pounds. The lectern worksurface is 34" wide and 30" deep with two cable holes with grommets and a surround. An optional logo plate can be added to the audience side of the lectern for institution branding.

The Equipment Rack can be mounted on the left or the right. The worksurface is 21" wide and 30" deep. The worksurface has a cutout with included cover. An optional power module can be added to this cutout. The Equipment rack has 36 rack units with 18 rack units accessible from the audience side and the presenter sides. The audience side has a locking door, and an optional locking door can be added to the presenter side. Other options can be added including rack-mount accessories (shelves, drawers, cooling fans, and others).

55355	Freedom One Lectern (Includes lectern, equipment rack, and unit-to-unit connector kit)
-------	--

55366	Equipment rack only
55367	Unit-to-unit connector kit
55368	Freedom One Lectern only

TW - 3" Twin-Wheel casters G - Bell glides	Base Options (Both options are included)
---	---

Page 7	Options and Accessories
--------	--------------------------------

Color Options

Standard laminate / color combinations

- Wild Cherry / Black (CHB)
- Indigo Organix / Black (IB)
- Fusion Maple / Black (FMB)
- Indigo Organix / Silver Sparkle (IS)
- Fusion Maple / Silver Sparkle (FMS)

Standard color combination refers to the quickest deliverable product color combination. Custom laminates and color combinations are available-additional lead-times and up-charges may apply. Call 1-800-235-1262 for further information.

Features and Benefits

- Adjustable-height workstation easily adjusts between varying seated or standing-use heights
- Smooth, easy lift mechanism with pneumatic spring and mechanical release
- Lightweight with a small overall footprint
- ADA-compliant
- Lectern / equipment rack can be assembled in a left or right-hand configuration
- Lectern available as a stand alone unit
- Surround on movable worksurface provides privacy and styling
- Equipment rack with rack-rail mounting 36RU (18RU front and 18RU rear) simplifies installation for any equipment configuration with enough space for an internal CPU
- Side equipment rack grommet holes and worksurface grommets provide superior cord access (covers included)
- Keyed locking audience-side (and optional front) door provides security and easy-access
- 3" swivel locking Twin-Wheel casters, and stationary bell glides are included (user choice)
- Ventilated equipment rack side panels keep equipment cool
- Scratch and impact resistant 1.0625" high-pressure laminate worksurfaces
- One rectangular equipment rack worksurface grommet provides cable access or the ability to mount an optional power module (cover included)
- Cable grommets throughout unit and cord channel provide easy cord routing
- One 2" grommet in bottom of equipment rack provides cord access below unit
- Two 2" cable grommets (left and right) on the adjustable worksurface provide cable access (covers included)
- Optional solid or acrylic door provides security and access to internal equipment
- Customizable modesty / logo panel (must be specified when ordering)
- Warranted to be free of all defects in materials and workmanship with a 10-year warranty

Construction

- The worksurfaces are constructed from 1.0625" thick NAUF (No Added Urea Formaldehyde) composite board with .030" high-pressure laminate on one face, and a balancing phenolic backer on the opposing face
- Metal components consist of 16-gauge and 20-gauge steel
- Worksurface edges are covered with 3mm vinyl
- All metal components are finished with a scratch-resistant powder coat epoxy
- Each Freedom One Lectern and equipment rack ships assembled. Customer assembles casters or glides and attaches equipment rack to lectern if required.

Specifications

Adjustable worksurface height	30"-42"H (with casters) 29.25"-41.25"H (with glides)		
Lectern	Lift capacity (factory-set): Additional weight on worksurface: 0-18 lbs - normal operation 18-38 lbs (max) - additional force needed to raise worksurface		
Equipment rack	Rack rail: 36RU (18RU front and 18RU rear) Note: <u>One</u> equipment rack can be attached to the lectern on the left <u>or</u> right side. Any additional racks have to be free-standing.		
ADA-compliance*	knee clearances: 33.5"W x 22.375"D x 29"H (1 person per lectern) <i>*Minimum ADA guidelines for knee clearances are 30"W x 19"D x 27"H</i>		
3" Twin-Wheel casters	weight capacity 165 lbs each (6 included)		
Worksurface grommet	7.25"W x 3.875"D		
Optional keyboard tray	21.375"W x 15.1875"D x 2.1875"H (available height to worksurface) <i>worksurface needs to be raised 3.375" for ADA-compliant knee clearance</i>		
weights (nominal)	Unit weights:	Shipping weights:	
	189 lbs	272 lbs	55355 - Freedom Lectern (all 3 components)
	N/A	94 lbs	55366 - Eq rack only
	N/A	10 lbs	55367 - Unit-to-unit kit only
	N/A	169 lbs	55368 - Freedom One Lectern only
Meets or exceeds applicable ANSI-BIFMA test standards			

Specifications subject to change without notice

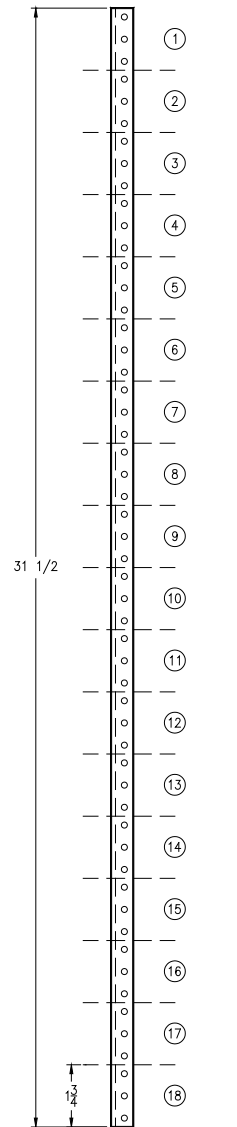
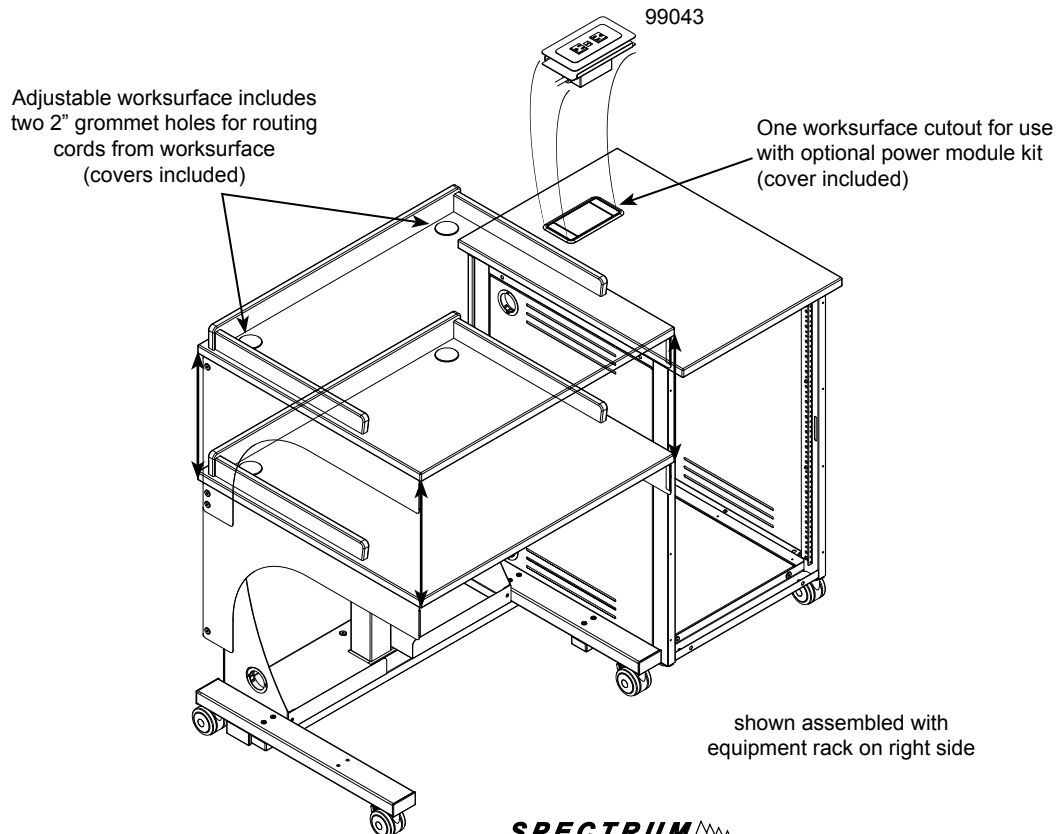

36RU available
(18RU front and 18RU rear)

**Freedom One Lectern
with equipment rack
55355**

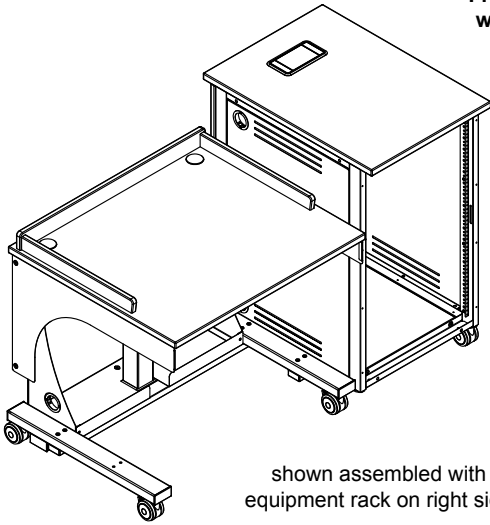

shown assembled with
equipment rack on right side

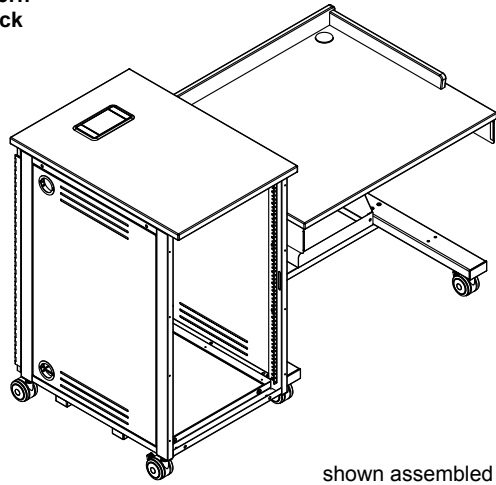

shown assembled with
equipment rack on left side

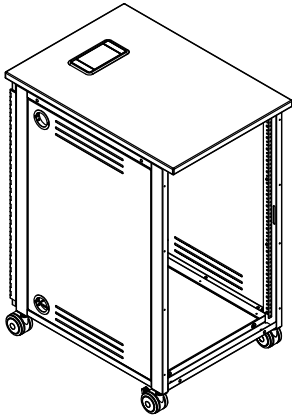

**Equipment rack
55366**

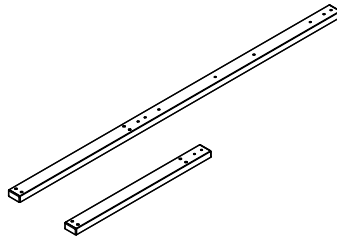

**Unit-to-unit connector kit
55367**

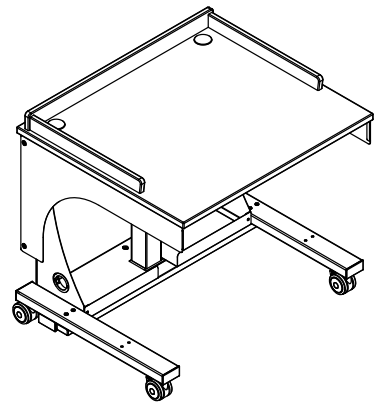

**Freedom One Lectern
55368**

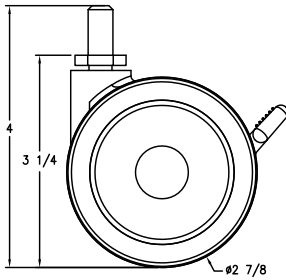
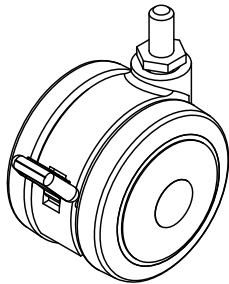

**3" Twin-Wheel caster
(TW)**

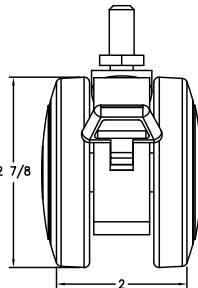

Note: Casters are made of
"soft thermoplastic".

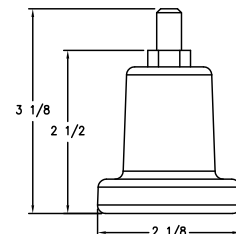
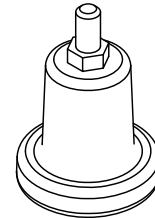

3" Bell Glide (G)

Freedom One Lectern
(right-assembled with TW casters)

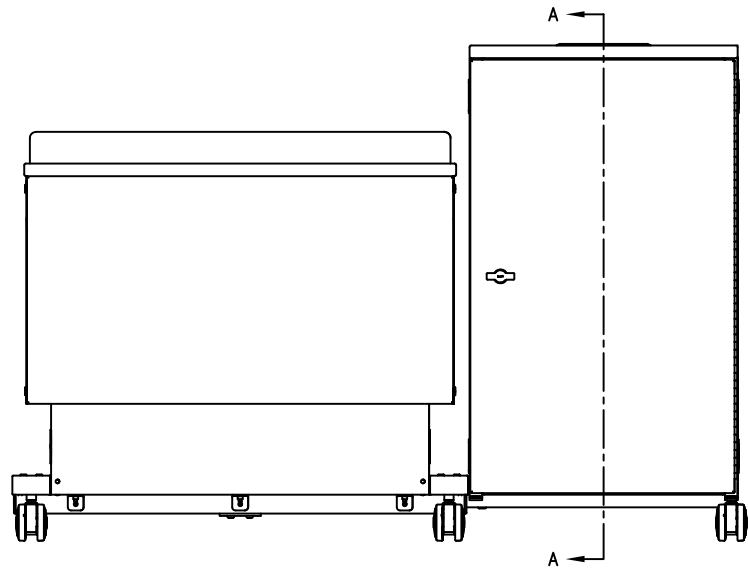
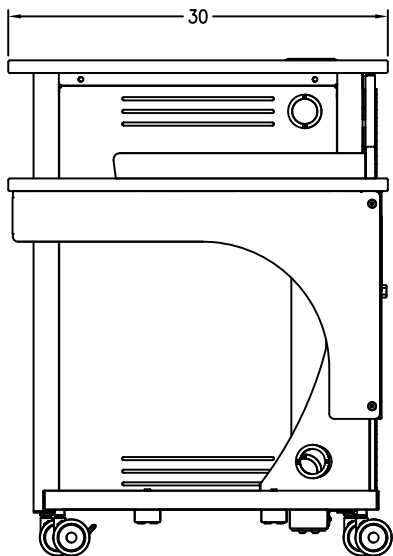
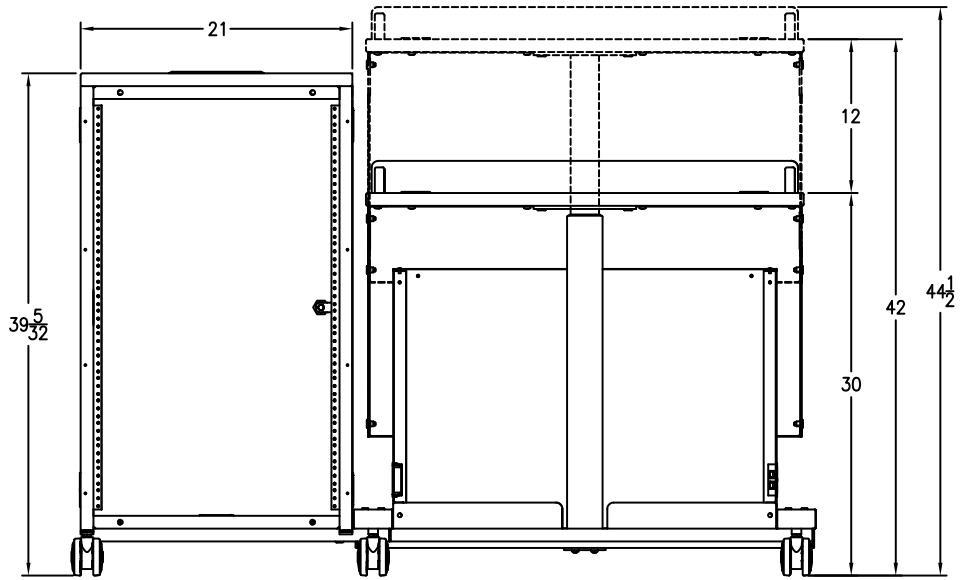
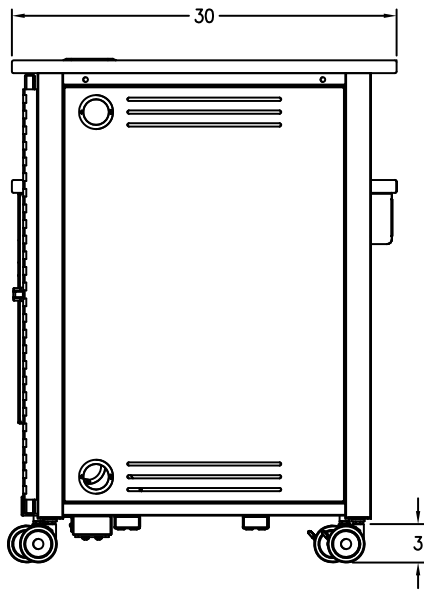
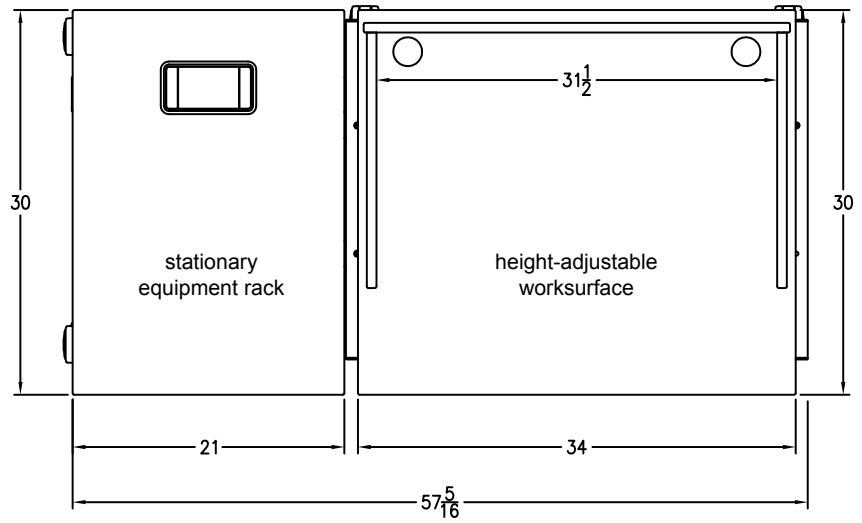

adjustable worksurface side view

audience side view

equipment rack
section view A-A

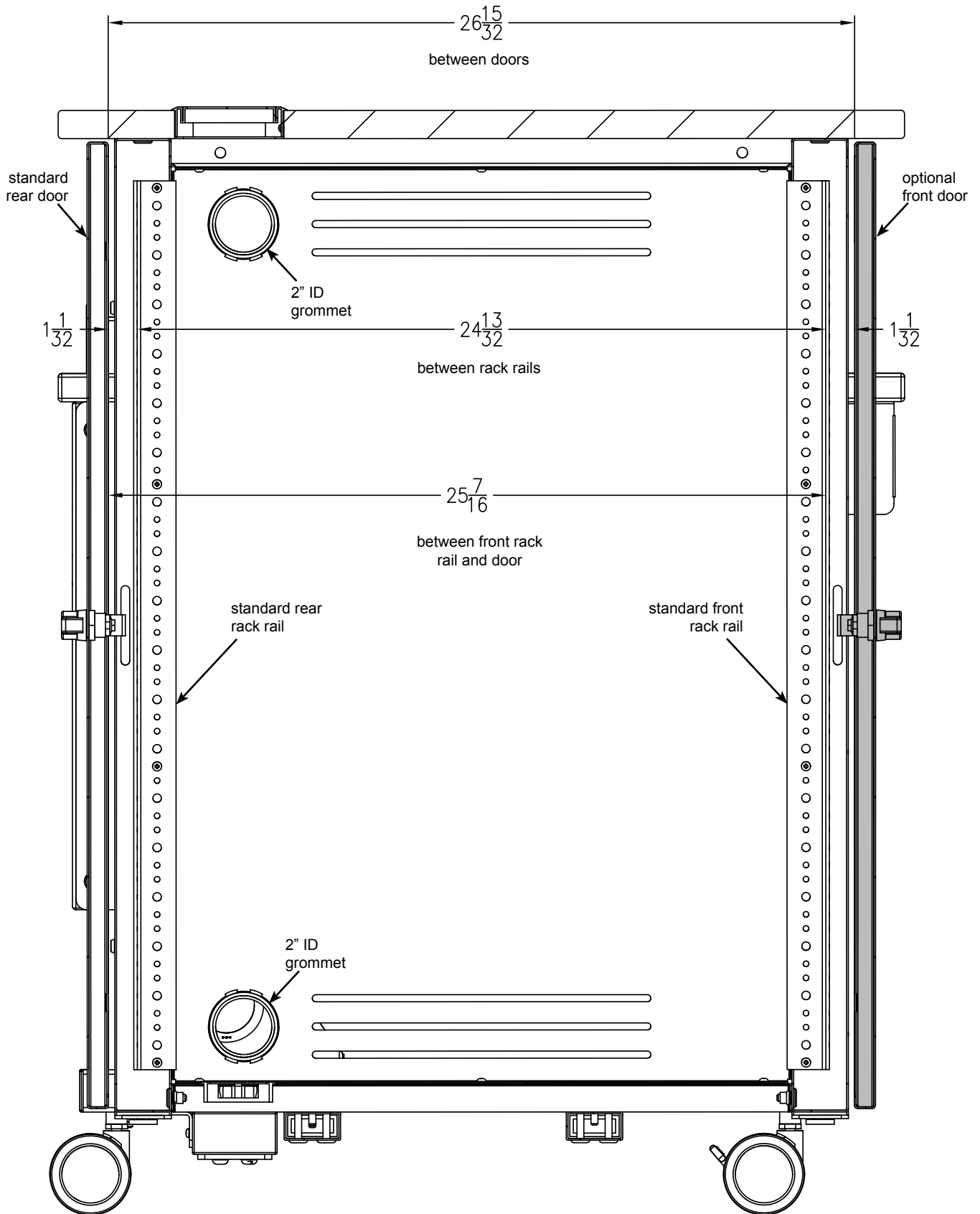

Note: Modified worksurface cutouts should be reviewed by Spectrum to ensure clearance of brackets, keyboard slides, or other objects under the worksurface. The weight of installed components should also be considered.

available cutout areas
(no keyboard tray)

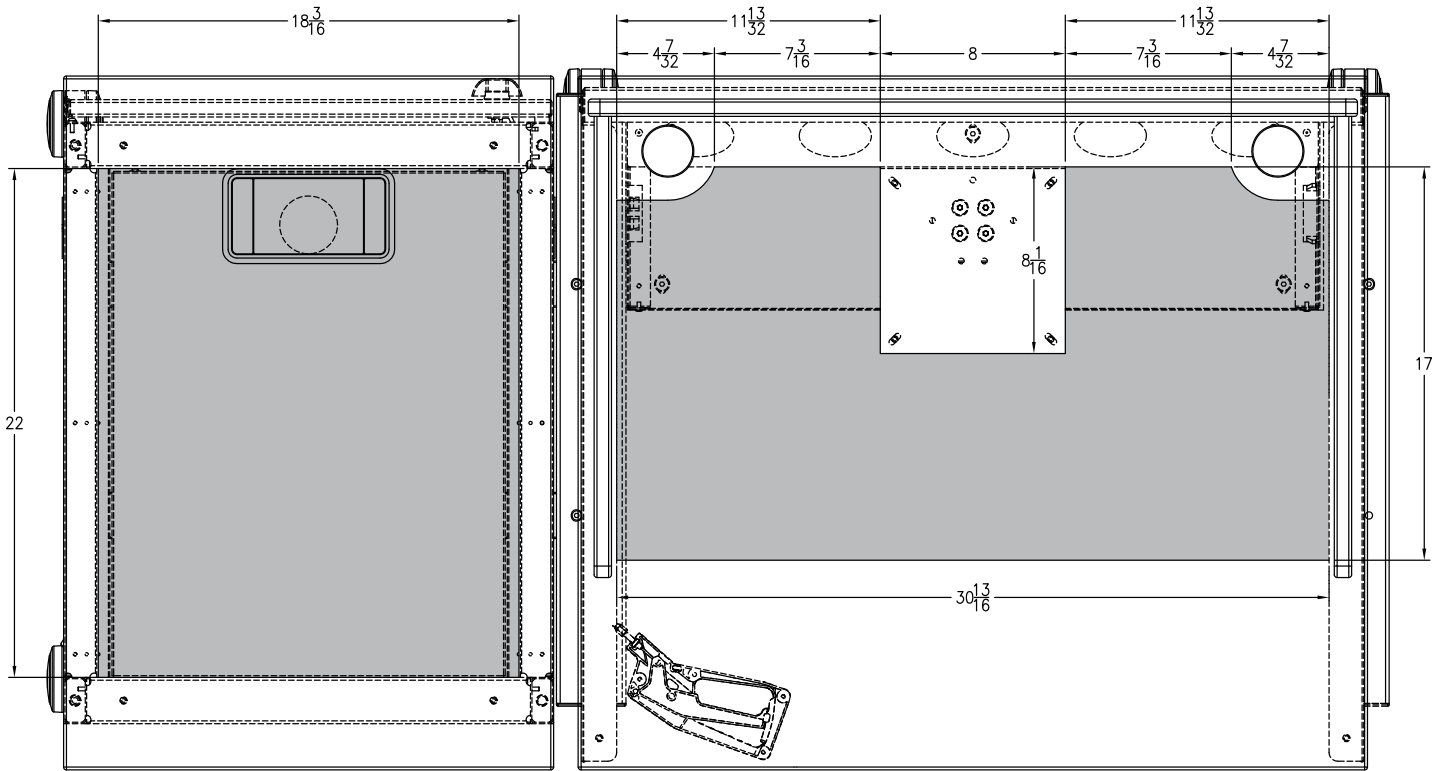

available cutout areas
with keyboard tray

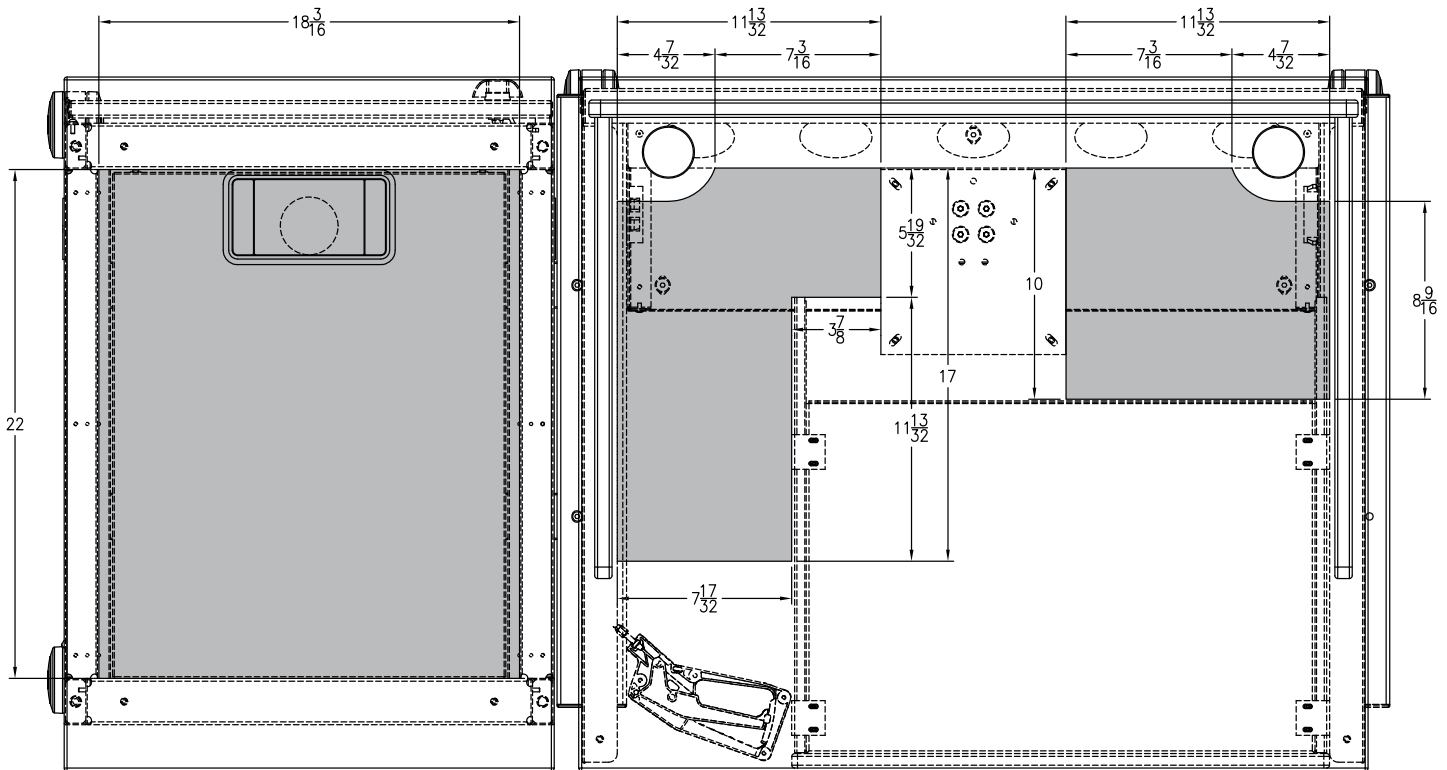

Options

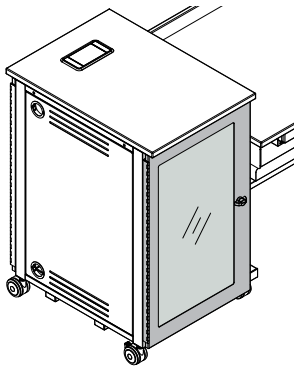

Clear Acrylic Locking Door
 (can be mounted to be hinged
 from the left or right-side)
 available in black or silver sparkle
 68153B
 68153S

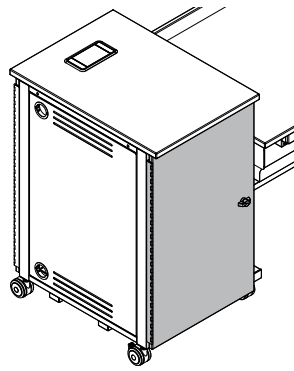

Solid Locking Door
 (can be mounted to be hinged
 from the left or right side)
 available in black or silver sparkle
 68152B
 68152S

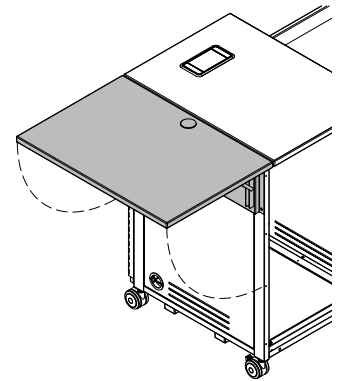

Flip-up Shelf
 21.1875"W x 30"D
 50 lbs max capacity
 (mtg plate available in black only)
 68204

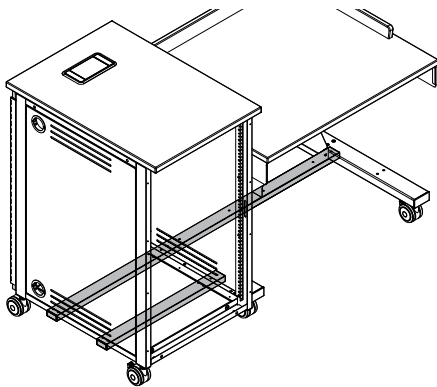

Unit-to-unit connector kit
 for connecting equipment rack to lectern
 (available in black or silver sparkle)
 55367

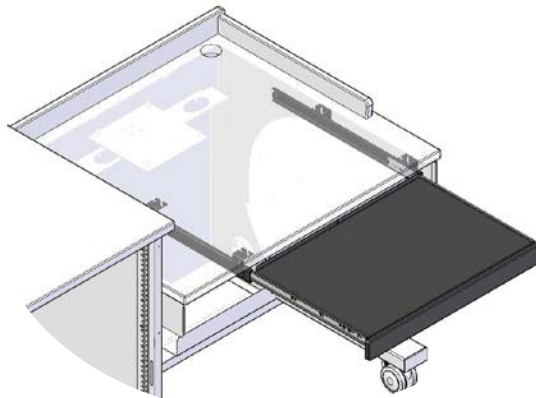

Keyboard Tray
 22"W x 15.1875"D x 1.1875"H
 (14 lbs)
 55356

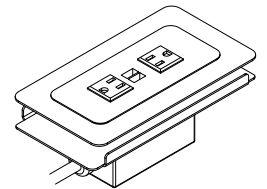

**Cove Power Module Kit
 with mounting plate**
 9' power cord, 2 AC outlets,
 2 USB charge ports
 7.5"W x 3.25"D x 4.25"H
 99043

Note: Worksurface has predrilled holes to simplify mounting. See capacity section for worksurface weight info. (38 lbs max weight on adjustable worksurface)

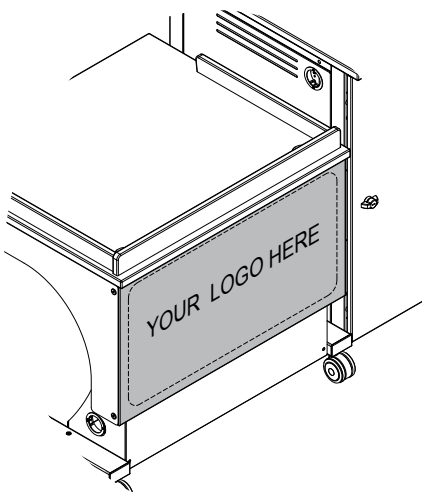

**Customized modesty panel with logo
 for Freedom One Lectern**
 (must be specified when ordering to get panel
 customized-contact Spectrum for details)

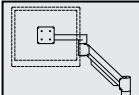

Flat Panel Monitor Arms and Tablet Mounts
 (See the Spectrum website or catalog for the latest available monitor arm and tablet mounting options)

Rack-mount accessories

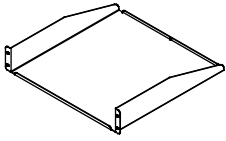

Cantilever Shelf (2RU)
17.5"W x 18"D x 3.5"H
(50 lbs max load)
97504

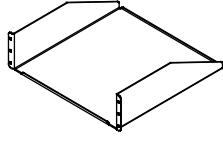

Cantilever Shelf (3RU)
17.5"W x 18"D x 5.25"H
(80 lbs max load)
97502

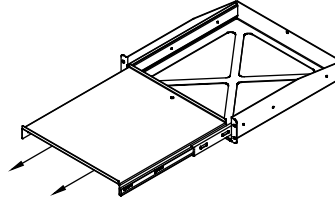

Pull-Out Shelf (2RU)
16.5"W x 17.75"D
(50 lbs max load)
97505

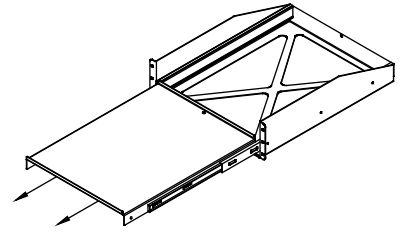

Pull-Out Shelf (3RU)
16.5"W x 21.75"D
(80 lbs max load)
97503

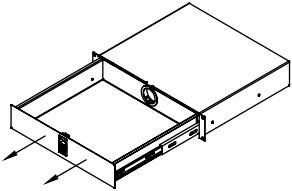

Locking Drawer (2RU)
interior dims:
15.75"W x 13.6875"D x 2.875"H
(25 lbs max load)
97514

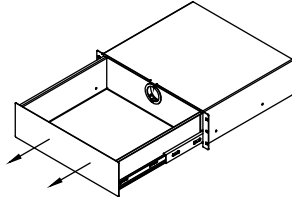

Drawer (3RU)
interior dims:
15.9375"W x 14.5"D x 5.25"H
(50 lbs max load)
97518

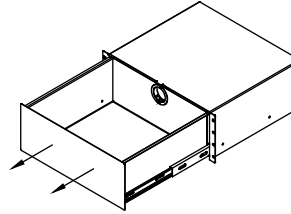

Drawer (4RU)
interior dims:
15.9375"W x 14.5"D x 7"H
(50 lbs max load)
97519

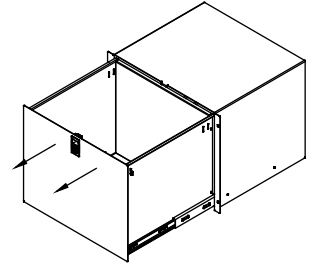

Locking File Drawer (8RU)
with file holder
interior dims:
15.75"W x 13.5625"D x
13.3125"H
(50 lbs max load)
97515

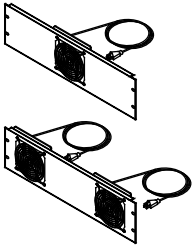

Cooling Fans (3RU)
19"W x 2"D x 5.25"H
Single Fan-97507
Double Fan-97506

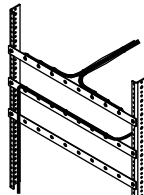

Wire Lace Kit
3 lace straps included
95517

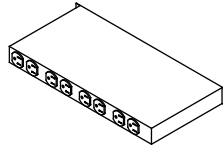

9-Outlet Power Strip (1RU)
19"W x 9"D x 1.75"H
99021

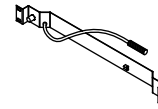

Flexible Halogen Light (1RU)
19"W x 2"D x 1.75"H
99033

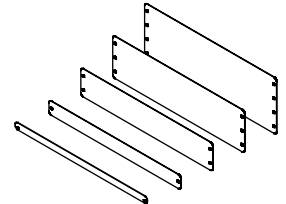

Rack-Mount Blanks
(fills rack spaces where components are not needed)

- 97516 - (1/2 RU)
- 97510 - (1RU)
- 97511 - (2RU)
- 97512 - (3RU)
- 97513 - (4RU)

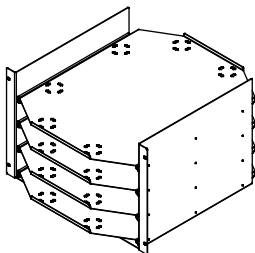

LT-4 Laptop Storage Unit (7RU)
(stores 4 laptops horizontally)
laptop tray dims:
16.25"W x 20.5"D x 2.1875"H
97517

Warranty

WE WILL MAKE IT RIGHT FOR YOU!

Spectrum is committed to provide complete customer satisfaction. Each of our products is manufactured from the best materials available and each product is stringently monitored throughout the production process through our P.A.C.E. program (Product Assurance to meet Customer Expectations).

We expressly warrant that Spectrum products will be of good quality and workmanship and free from defect for the period set out in the warranty table below from the date of delivery. This warranty shall not apply to defects or damage resulting from misuse, abuse, neglect, improper care, modification or repair not authorized by Spectrum, or any other cause outside the control of Spectrum. Spectrum will, at its sole option, either repair or replace the defective product.

This warranty is exclusive; no other warranty, written or oral, is expressed or implied. This warranty is given by Spectrum to Buyer and to no other person or legal entity. No Spectrum dealer, distributor, agent or employee is authorized to make any modification or addition to this warranty.

NOTWITHSTANDING ANYTHING TO THE CONTRARY, SPECTRUM WILL NOT UNDER ANY CIRCUMSTANCES BE LIABLE FOR INDIRECT OR LIQUIDATED DAMAGES, INCLUDING CONSEQUENTIAL, INCIDENTAL AND SPECIAL DAMAGES. IN NO EVENT SHALL SPECTRUM'S LIABILITY, WHETHER UNDER CONTRACT OR WARRANTY, IN TORT OR OTHERWISE, EXCEED THE PURCHASE PRICE RECEIVED BY SPECTRUM FOR THE PRODUCT AT ISSUE AND "RECALL ACTION" EXPENSES. SPECTRUM SHALL NOT BE SUBJECT TO ANY OTHER OBLIGATIONS OR LIABILITIES, WHETHER ARISING OUT OF BREACH OF CONTRACT, WARRANTY, TORT (INCLUDING NEGLIGENCE AND STRICT LIABILITY) OR OTHER THEORIES OF LAW, WITH RESPECT TO PRODUCTS SOLD OR SERVICES RENDERED BY SPECTRUM, OR ANY UNDERTAKINGS, ACTS OR OMISSIONS RELATING THERETO.

Our Customer Service Department is ready to provide immediate attention to any questions, comments or concerns. They are available to answer your calls Monday through Friday from 7 am to 5 pm CST. In addition your product comments or concerns are welcome via e-mail at: spectrum@spectrumfurniture.com.

Warranty Table

Item	Warranty Period
<ul style="list-style-type: none"> Adjustable Crank/Electric Desk Legs Flat Panel Desk Gas Cylinders 	<ul style="list-style-type: none"> 1 Year
<ul style="list-style-type: none"> Adjustable Height Chair Parts – including frames, gas cylinders, wood and plastic parts, and control handles Adjustable Height Chair Parts Casters Adjustable Height Chair Upholstery In-Stock Upholstery Graded-In Fabrics and Customer Owned Material 	<ul style="list-style-type: none"> 7 Years 2 Years 2 Years No Warranty
<ul style="list-style-type: none"> Height Adjustable Columns and Lifts General Use Casters Electrical Keyboard/Mouse Trays 	<ul style="list-style-type: none"> 1 Year
<ul style="list-style-type: none"> Flat Panel Monitor Arm – General Parts Flat Panel Monitor Arm – Gas Cylinders 	<ul style="list-style-type: none"> 5 Years 2 Years
<ul style="list-style-type: none"> Computer Desk Chassis Cart Chassis Lectern Chassis 	<ul style="list-style-type: none"> 10 Years

Touchboards

205 Westwood Ave, Long Branch, NJ 07740
 Phone: 866-94 BOARDS (26273) / (732)-222-1511
 Fax: (732)-222-7088 | E-mail: sales@touchboards.com

