

Assembly Instructions

Important

Before you begin, please make sure all parts and proper quantities are included. Any parts damaged during shipment must be reported within 15 days of receipt. To report information regarding damage, to purchase parts or accessories, or if you have any questions, please contact us at:

www.spectrumfurniture.com
 715-723-6750, 800-235-1262

Thank you for purchasing Spectrum products!

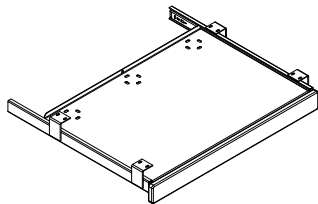

(1) 0114290
 keyboard tray

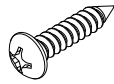

(8) 026073
 #8 x 3/4" PHSM screw



(3) 052608
 3/4" x 5" Velcro® strap

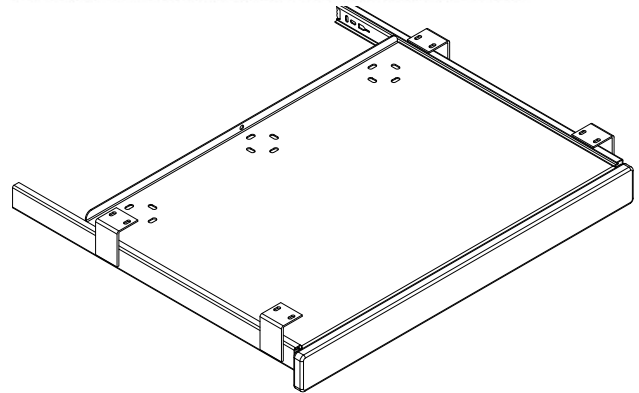

Keyboard Tray
 55356



Keyboard tray installation

1. If possible, install the keyboard tray with the worksurface face down.
2. Pull the keyboard tray slides out and align the slide bracket mounting holes with the pre-drilled worksurface mounting holes. **Figure 1.**

Note: If the worksurface does not have predrilled mounting holes, use the slide brackets as a template to mark the mounting hole locations onto the worksurface with a pencil, then drill each hole location with a 1/8" drill bit about 3/4" deep. Be careful not to drill completely through the worksurface.

3. Install (8) #8 x 3/4" PHM screws through the slide brackets and tighten securely.
4. Use slots in tray & Velcro straps to secure cords.

Tools Required

-  Phillips screwdriver
-  electric drill (optional)
-  1/8" drill bit (optional)

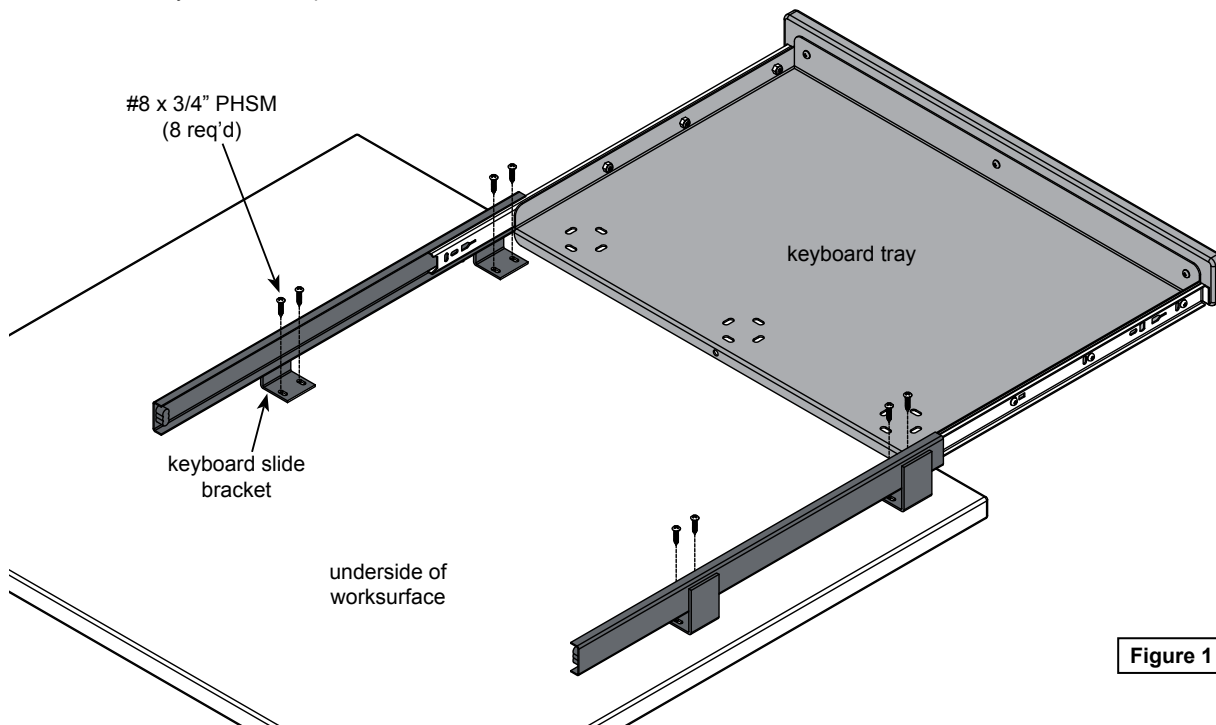

Figure 1