

## Technical Specifications

55357

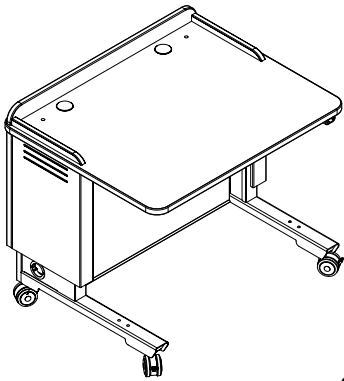

Lectern with surround

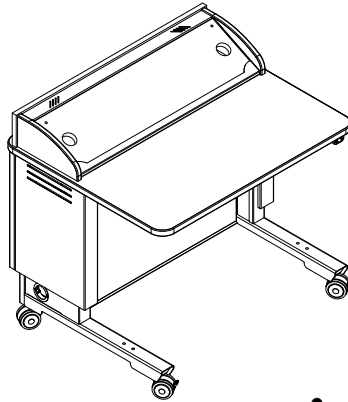

Lectern with overbridge

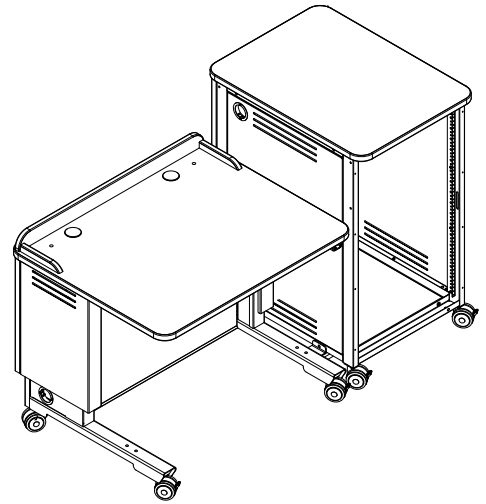

Lectern with surround and equipment rack attached to right side



Use the Freedom One e-Lift Lectern where worksurface height adjustment, ADA compliance, or rack rail equipment storage is required. The lectern can have either glides or casters installed for stationary or mobile use. Electric actuators provide worksurface height adjustment from 28.5-42" and have a lift capacity of 500 lb. The lectern is available with a surround and grommets, or an overbridge version. An optional logo panel can be added to the audience side of the lectern for institution branding. The Equipment rack has 18 rack units accessible from the audience and presenter sides, and can be mounted on the left or the right side of the lectern. Other options can be added including rack-mount accessories (shelves, drawers, cooling fans, and others).

## Features and Benefits

### Lectern:

- Electric eLift adjustable-height worksurface easily adjusts between varying seated or standing-use heights
- Lightweight with a small overall footprint
- ADA-compliant
- Surround on worksurface provides privacy and styling (surround version)
- Worksurface grommet holes provide superior cord access (surround version)
- Casters or glides factory-assembled
- Full-length modesty panel (worksurface to casters)
- Kick panel and wire loom protect cables during worksurface movement
- Overbridge version with blank panel allows custom cutouts and installation of electronics
- Lectern and equipment rack can be assembled in a left or right-hand configuration
- Cable grommets throughout lectern provide cable access
- Pre-drilled monitor arm mounting holes allow easy installation of a monitor arm (surround version only)
- Optional tray can be used as a keyboard tray or storage drawer
- Optional quick-change customizable logo panel simplifies adding or changing logos
- Available as a stand-alone lectern

### Equipment Rack:

- Rack-rail mounting (18RU front and 18RU rear) simplifies installation for any equipment configuration
- Ventilated side panels keep equipment cool
- Removable audience-side panel included
- Casters or glides assembled by customer
- Optional front solid or acrylic door provides security and access to internal equipment
- Two 2" grommets in each side panel provide cord access
- Unit-to-unit kit easily connects the equipment rack and lectern while in an upright position (no flipping needed)
- Available as a stand-alone unit

### Misc:

- 3" Swivel locking Twin-Wheel stem casters provide easy rolling
- Optional stationary glides available if mobility is not necessary or desired
- Scratch and impact-resistant high-pressure laminate tops provide durable, useful worksurfaces
- Durable powder coated steel chassis provides a long-lasting finish
- Warranted to be free of all defects in materials and workmanship for 10 years
- Designed and assembled in Chippewa Falls, WI, USA

Note: Not designed to be permanently anchored to the floor. Optional glides are available if a stationary lectern is needed.

## Color Options

See [spectrumfurniture.com](http://spectrumfurniture.com) for complete color options and combinations.

# Construction

- The worksurfaces are constructed from 1" thick NAF (No Added Formaldehyde) composite board plus .030" high-pressure laminate on one face, and a balancing phenolic backer on the opposing face
- Metal components consist of 16-gauge steel
- Worksurface edges are covered with 3mm vinyl
- All metal components are finished with a scratch-resistant powder coat epoxy
- Each Freedom One eLift Lectern ships assembled with casters/glides. Equipment rack ships without casters/glides (installed by customer). Unit-to-unit kit is required to attach equipment rack to lectern.

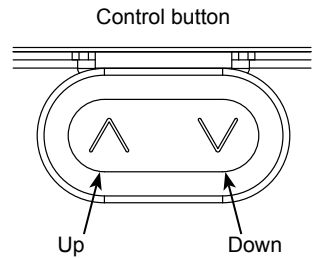

# Specifications

eLift Lectern worksurface height adjustability (floor to top of worksurface)	42"H [106.7 cm] (fully-raised with casters) 28.5"H [72.4 cm] (fully-lowered with casters)	
eLift Lectern electrical	<ul style="list-style-type: none"> <li>• Range of motion: 13.5" [34.3 cm]</li> <li>• ~9.7 seconds from fully-lowered to fully-raised</li> <li>• Inverter: 120V @ 60Hz, max output 400 watts</li> <li>• Motors: 18V / 10 amps</li> <li>• Typical electrical load during operation: <b>4.3 amps @ 120 VAC</b></li> <li>• Anti-collision protection for safety</li> <li>• 11' [335 cm] nominal 3-wire power cord</li> </ul>	<ul style="list-style-type: none"> <li>• Casters/glides factory-assembled</li> <li>• Max load: 1200N (270 lb) [122.6 kg] per actuator total lift capacity: 540 lb [245 kg]</li> <li>• Actuators feature non-hydraulic, permanently lubricated screw jacks</li> <li>• Actuators rated for 20,000 cycles</li> <li>• Tested at 1000 cycles at 300 lb</li> <li>• Approved according to EN 60335-1 and UL 962</li> </ul>
Equipment rack	<ul style="list-style-type: none"> <li>• Rack rail: 18RU</li> <li>• Front and rear rack rails</li> <li>• Standard audience-side panel included</li> <li>• Casters/glides assembled by customer</li> </ul>	<ul style="list-style-type: none"> <li>• 39.11"H [99.3 cm] worksurface height (with casters)</li> <li>• Two 2" grommets in each side panel provide cord access</li> <li>• One equipment rack can be attached to the left <u>and</u> right sides of the lectern.</li> </ul>
3" Twin Wheel casters	<ul style="list-style-type: none"> <li>• Weight capacity 165 lb [74.9 kg] each</li> <li>• 1/2-13 threaded stem</li> <li>• 4 on equipment rack, 4 on lectern</li> </ul>	
ADA-compliance*	Knee clearance: 30"W [76.2 cm] x 19"D [48.26 cm] x 27.26"H [69.2 cm] (1 person per lectern)	<p><i>*Minimum ADA guidelines for knee clearances are 30"W [76.2 cm] x 19"D [48.3 cm] x 27"H [68.6 cm]</i></p> 
Certifications / Compliance	<ul style="list-style-type: none"> <li>• SCS Indoor Advantage Certified</li> <li>• TAA compliant</li> </ul>	<ul style="list-style-type: none"> <li>• Meets or exceeds applicable ANSI-BIFMA test standards</li> </ul>
Unit weight (nominal)	243 lb [110.3 kg] - Freedom One Lectern (all 3 components) 151 lb [68.6 kg] - Freedom One Lectern only 83 lb [37.7 kg] - Equipment rack only 9 lb [4.1 kg] - Unit-to-unit bracket	

Specifications subject to change without notice

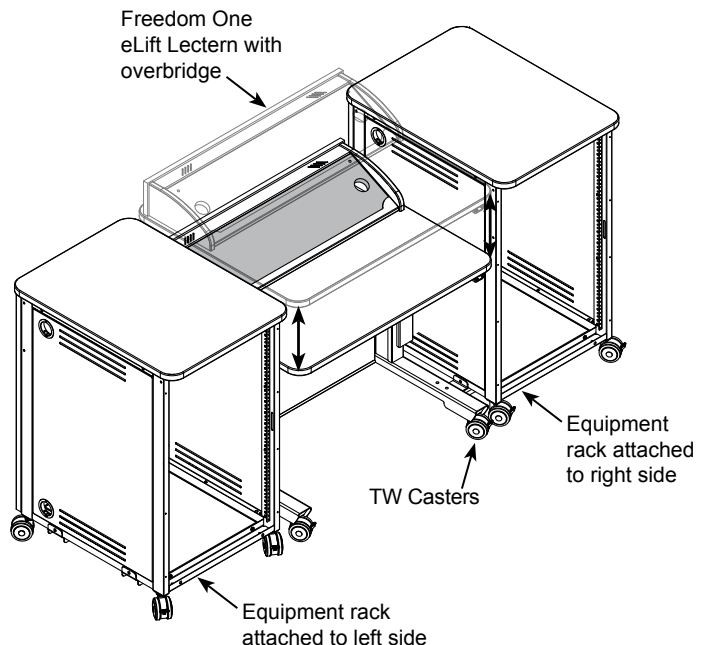
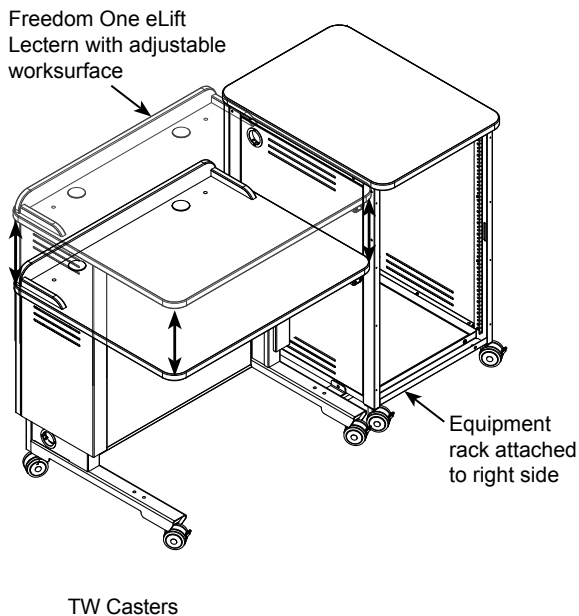

# Configured Number Breakdowns

**55357 - FM BK CM S1 01 1 1 0 1 0 0**

Parent Number

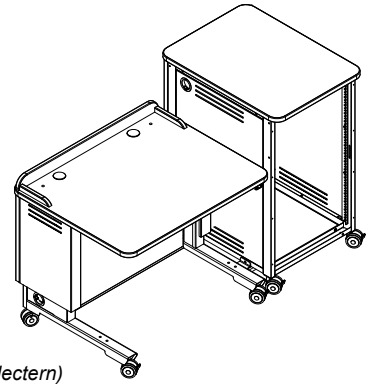

**Cove Power Module:**

- 0 = None
- B = Black
- S = Silver

**Customized Logo Panel:** (Factory-installed)

- 0 = None
- 1 = with Custom Logo Panel (metal color matches lectern)

**Keyboard Tray:** (Factory-installed)

- 0 = None
- 1 = with Keyboard Tray (black)

**Flip-up shelf on Equipment Rack:** (Factory-installed)

- 0 = None
- 1 = with Flip-up shelf (laminates and metal colors match equipment rack)

**Door on Equipment Rack:** (Customer-installed) (metal color matches equipment rack)

- 0 = None
- 1 = with Solid door
- 2 = with Acrylic door

**Equipment Rack:** (Customer attaches to lectern) (laminates and metal colors match lectern)

- 0 = None
- 1 = with Equipment Rack
- 2 = with Equipment Rack-with custom cutout(s) in worksurface
- 5 = with Equipment Rack-with Cove Power Module in worksurface (factory-installed)

**Base Type:** (Factory-installed on lectern, customer-installed on equipment rack)

- 01 = Twin Wheel Casters
- 02 = Glides

**Lectern Style:**

- S1 = with Surround
- S2 = with Surround and custom cutout(s)
- S4 = with Surround and Cove Power Module (factory-installed)
- B1 = with Overbridge (blank OB panel)
- B2 = with Overbridge and custom cutout(s) in OB panel

**Metal Color:**

- B = Black
- CM = Champagne Metallic
- D = Dark Gray
- S = Silver Sparkle

	<b>Laminate Color:†</b>	<b>Edgeband Color:</b>
Standard Laminates	FM = Fusion Maple	FM = Fusion Maple
	IO = Indigo Organix	BK = Black (non-matching)
	CH = Wild Cherry	CH = Wild Cherry
Premium Laminates* (28-day lead time)	BK = Black	BK = Black
	BL = Bronze Legacy	BL = Bronze Legacy
	CK = Castle Oak	CK = Castle Oak
	CW = Colombian Walnut	CW = Colombian Walnut
	DZ = Desert Zephyr	DZ = Desert Zephyr
	EM = Empire Mahogany	EM = Empire Mahogany
	MO = Morro Zephyr	MO = Morro Zephyr
	MZ = Misted Zephyr	SN = Silver Northsea (non-matching)
	NP = Nepal Teak	NP = Nepal Teak
	NT = Natural Tigris	NT = Natural Tigris
	PM = Pewter Mesh	PM = Pewter Mesh
	SM = Steel Mesh	SM = Steel Mesh
	TZ = Twilight Zephyr	TZ = Twilight Zephyr
	WF = White Fiesta	BK = Black (non-matching)
WD = White Chalk Dry Erase	(Matches Laminate Color)	

Note: White Chalk Dry Erase laminate is only available on the flip-up shelf option-not the worksurface.

Note: Flip-up shelves configured with white laminate will have the same edgeband color as the worksurface.

All configured options are factory-installed unless noted otherwise.

\* Premium laminate colors require an additional 14 days of lead time.

† Laminate colors come with matching edgeband color, with these exceptions: Indigo Organix Laminate comes with Black edgeband, Misted Zephyr Laminate comes with Silver Northsea edgeband, and White Fiesta Laminate comes with Black edgeband.

Lectern Style

**ORDER CODE S1 = Surround**

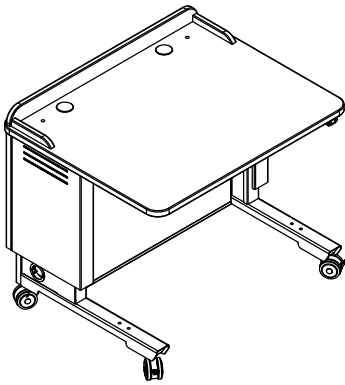

**ORDER CODE S2 = Surround with custom cutout(s)**

- Contact Spectrum to specify cutout size(s) and location(s)
- See p.11 for location recommendations

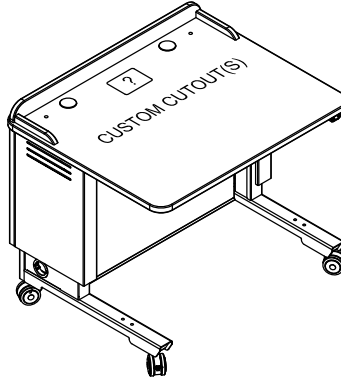

**ORDER CODE S4 = Surround with Cove™ cutout**

- Centered on worksurface
- Select Cove™ Power Module option

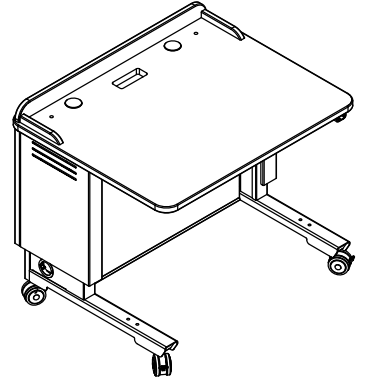

**ORDER CODE B1 = Overbridge**

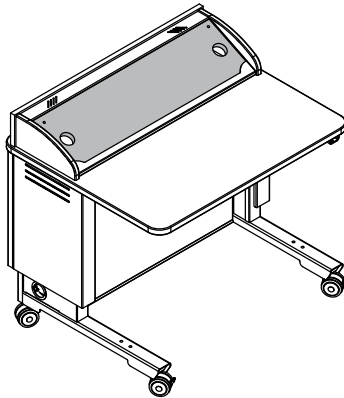

**ORDER CODE B2 = Overbridge with custom cutout(s)**

- Contact Spectrum to specify cutout size(s) and location(s)
- See p.12 for location recommendations

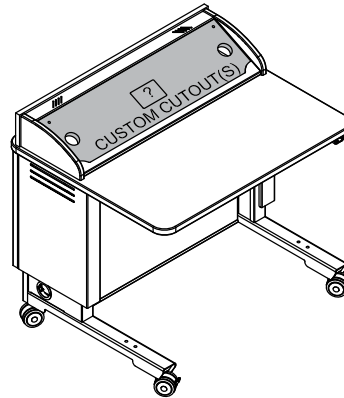

Base

**ORDER CODE 01 = 3" Twin-wheel casters**

- For mobile use
- Black, soft thermoplastic
- 3.21"H [8.15 cm]
- Factory installed on Lectern
- 1/2-13 threaded stem
- Customer installed on Equipment Rack

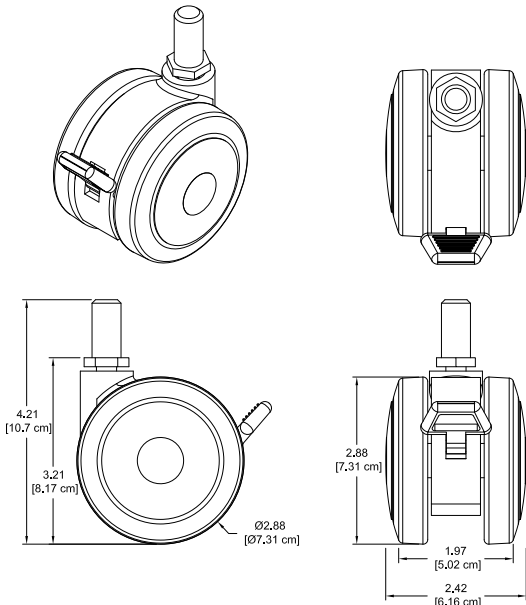

**ORDER CODE 02 = Glides**

- For stationary use
- Black high-impact plastic
- .69"H [1.75 cm]
- Factory installed on Lectern
- 1/2-13 threaded stem
- Customer installed on Equipment Rack

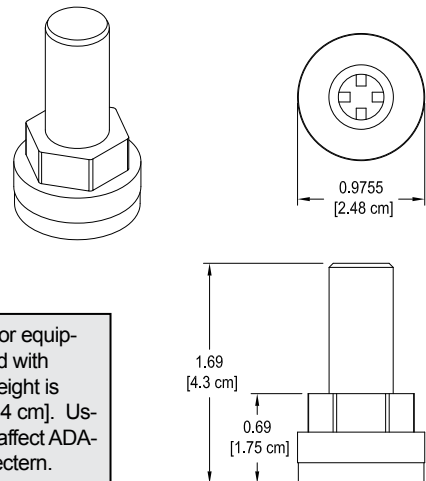

Note: If the lectern or equipment rack is ordered with glides, the overall height is lowered by 2.52" [6.4 cm]. Using glides does not affect ADA-compliance of the lectern.

Equipment Rack

**ORDER CODE 0** = None  
**ORDER CODE 1** = Equipment Rack

- Includes unit-to-unit connector kit

**ORDER CODE 2** = Equipment Rack with custom cutout(s)

- Contact Spectrum to specify cutout size(s) and location(s)
- See p.11 for location recommendations
- Includes unit-to-unit connector kit

**ORDER CODE 5** = Equipment Rack with Cove™ cutout

- Centered on worksurface
- Includes unit-to-unit connector kit
- Select Cove™ Power Module option

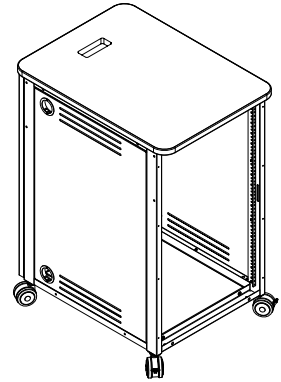
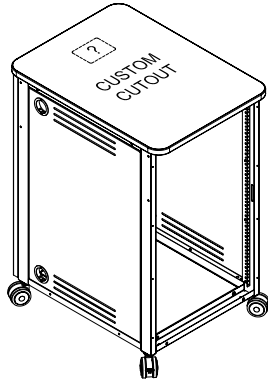
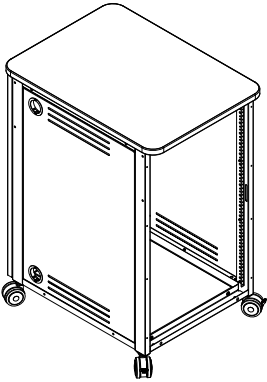

Door on Equipment Rack

**ORDER CODE 0** = None  
**ORDER CODE 1** = Solid Locking Door

- Locking
- For instructor-side installation
- Can be installed to be hinged from the left or right side

**ORDER CODE 2** = Clear Acrylic Locking Door

- Locking
- For instructor-side installation
- Can be installed to be hinged from the left or right side

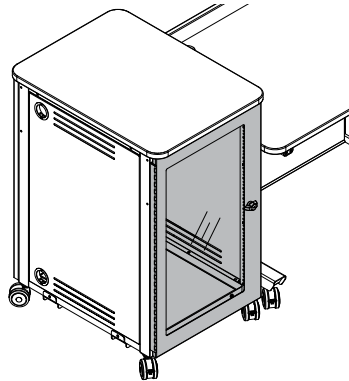
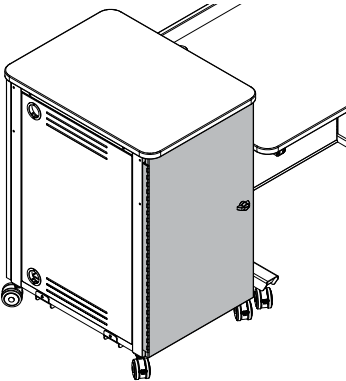

Flip-up Shelf on Equipment Rack

**ORDER CODE 0** = None  
**ORDER CODE 1** = Flip-up Shelf

- 21.1875"W [53.8 cm] x 30"D [76.2 cm] x 1"H [2.54 cm]
- 35 lb [15.9 kg] max capacity
- Includes 2" grommet

Not for use on stand-alone equipment racks.

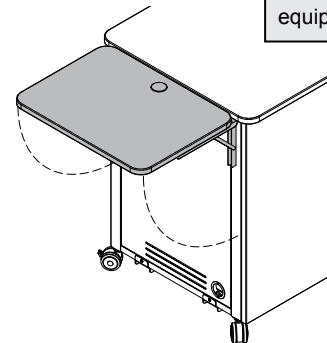

Keyboard Tray

**ORDER CODE 0** = None  
**ORDER CODE 1** = Keyboard Tray

- 22"W [55.9 cm] x 13.815"D [35.1 cm] x 4"H
- Wire management slots in tray
- Tray can also be installed flipped and used as a storage drawer

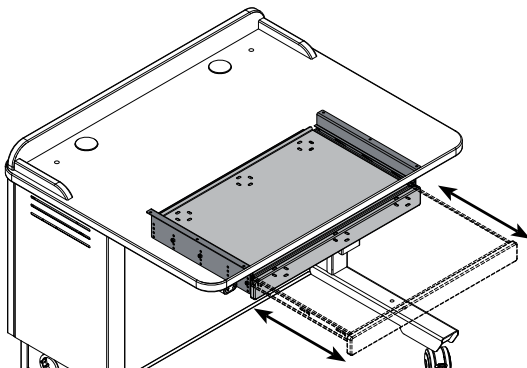

Customized Logo Panel

**ORDER CODE 0** = None  
**ORDER CODE 1** = Customized Logo Panel

- Attaches to audience-side of lectern
- To get panel customized-contact Spectrum for details
- New logos require a first time logo charge



<b>ORDER CODE 0</b> =	None
<b>ORDER CODE B</b> =	Yes - Black
<b>ORDER CODE S</b> =	Yes - Silver

**Cove™ Power Module**

- Two power receptacles
- Two USB charge ports (not data-compatible)
- Thumbscrew clamps
- Requires worksurface cutout
- ETL listed
- Available in Black or Silver

Cutout required:	5.25"W [13.3 cm] x 2"D [5.1 cm] (mounts to surface thicknesses up to 1.5")
Power cord:	9' [274 cm] with 90° flat plug with 45° rotation
Power receptacles:	12A, 120 VAC spill-resistant
USB charging ports:	2.1A (10.5W)
Dimensions:	6"W [15.2 cm] x 2.5"D [6.35 cm] x 3.18"H [8.1 cm]
Unit weight:	2.29 lb [1 kg]

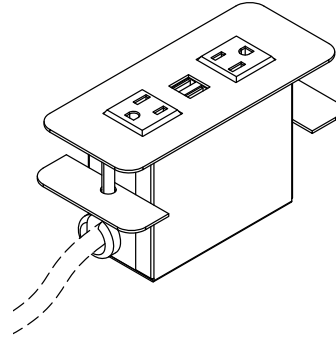

**Black Cove™ Power Module**



**Silver Cove™ Power Module**

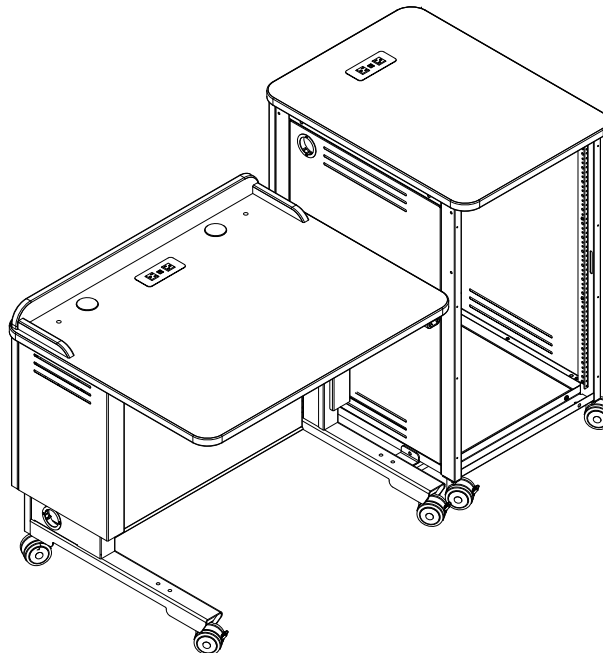

# Equipment Rack Only

Note: This product number and breakdown is used when ordering the equipment rack only.

The flip-up shelf option is not available or recommended for use on stand-alone equipment racks.

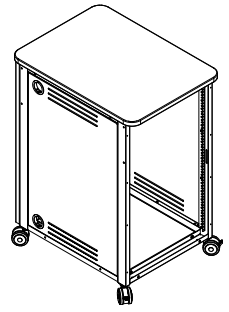

## 55358 - FM BK CM 01 1 2

**Parent Number**

**Equipment Rack Door:** (Customer-installed) (metal color matches equipment rack)

- 0 = None
- 1 = with Solid door
- 2 = with Acrylic door

**Equipment Rack:**

- 1 = with standard worksurface
- 2 = with custom cutout(s) in worksurface
- 5 = with Cove Power Module in worksurface (factory-installed)

**Base:** (Customer-installed)

- 01 = Twin Wheel Casters
- 02 = Glides

**Metal Color:**

- B = Black
- CM = Champaign Metallic
- D = Dark Gray
- S = Silver Sparkle

	Laminate Color:†	Edgeband Color:
Standard Laminates	FM = Fusion Maple	FM = Fusion Maple
	IO = Indigo Organix	BK = Black (non-matching)
	CH = Wild Cherry	CH = Wild Cherry
Premium Laminates* (28-day lead time)	BK = Black	BK = Black
	BL = Bronze Legacy	BL = Bronze Legacy
	CK = Castle Oak	CK = Castle Oak
	CW = Colombian Walnut	CW = Colombian Walnut
	DZ = Desert Zephyr	DZ = Desert Zephyr
	EM = Empire Mahogany	EM = Empire Mahogany
	MO = Morro Zephyr	MO = Morro Zephyr
	MZ = Misted Zephyr	SN = Silver Northsea (non-matching)
	NP = Nepal Teak	NP = Nepal Teak
	NT = Natural Tigris	NT = Natural Tigris
	PM = Pewter Mesh	PM = Pewter Mesh
	SM = Steel Mesh	SM = Steel Mesh
	TZ = Twilight Zephyr	TZ = Twilight Zephyr
	WF = White Fiesta	BK = Black (non-matching)
	WD = White Chalk Dry Erase	(Matches Laminate Color)

Note: White Chalk Dry Erase laminate is only available on the flip-up shelf option-not the worksurface.

Note: Flip-up shelves configured with white laminate will have the same edgeband color as the worksurface.

All configured options are factory-installed unless noted otherwise.

\* Premium laminate colors require an additional 14 days of lead time.

† Laminate colors come with matching edgeband color, with these exceptions: Indigo Organix Laminate comes with Black edgeband, Misted Zephyr Laminate comes with Silver Northsea edgeband, and White Fiesta Laminate comes with Black edgeband.

revised 10/5/16

Freedom One eLift Lectern  
 shown with surround, TW casters,  
 right-assembled equipment rack,  
 and keyboard tray

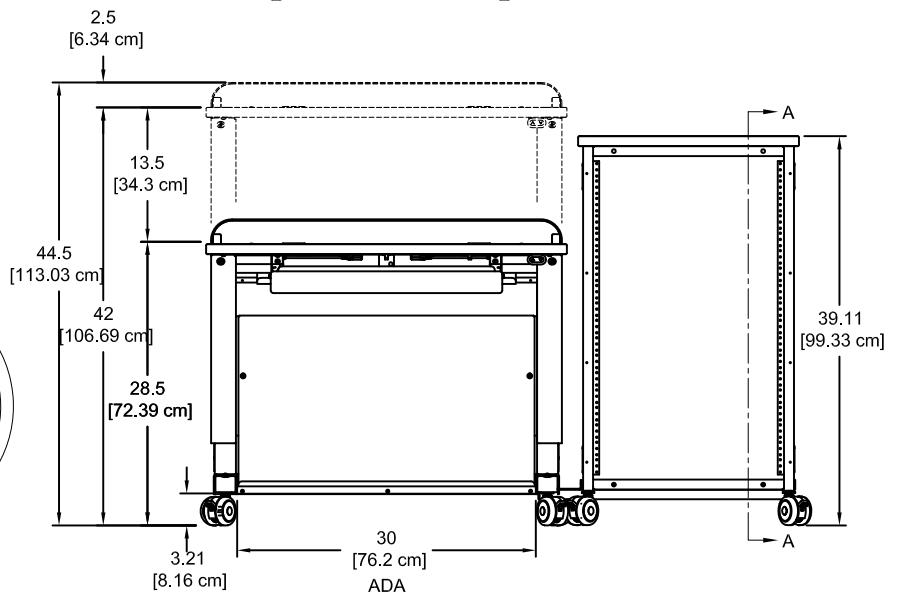
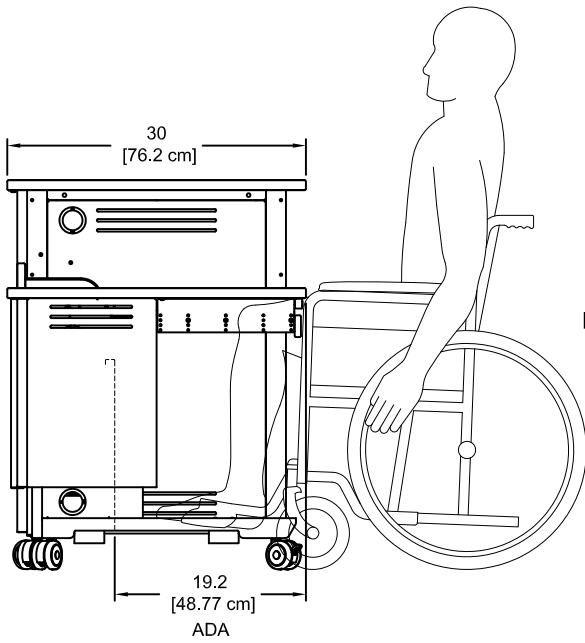
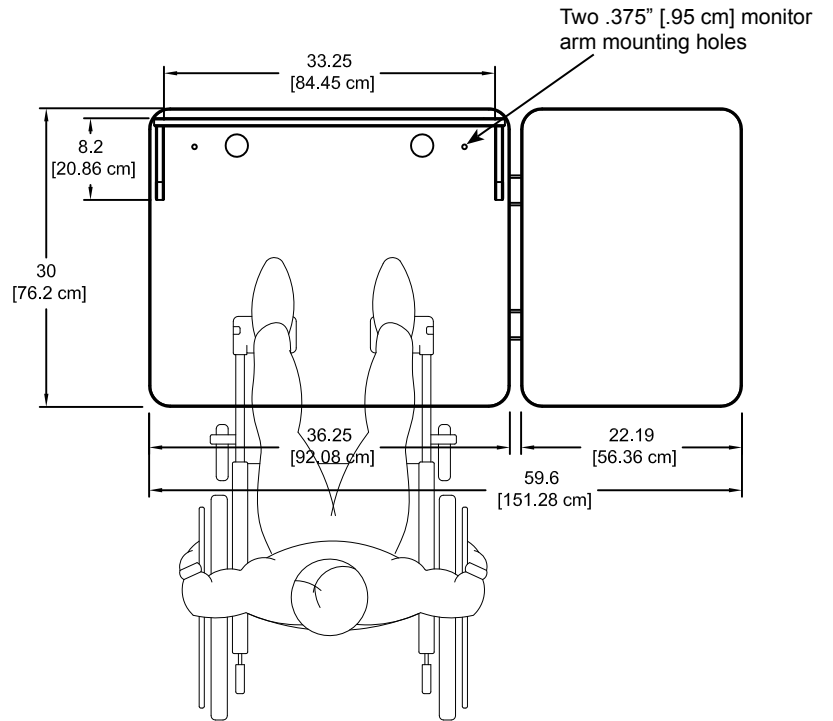
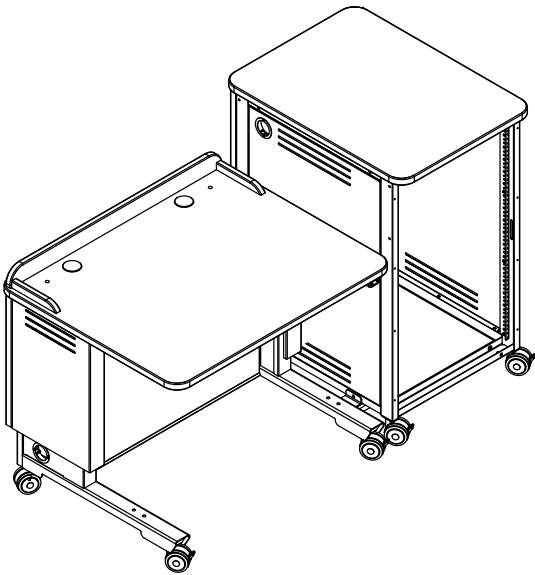



Freedom One eLift Lectern  
 shown with overbridge, TW casters,  
 right-assembled equipment rack,  
 and keyboard tray

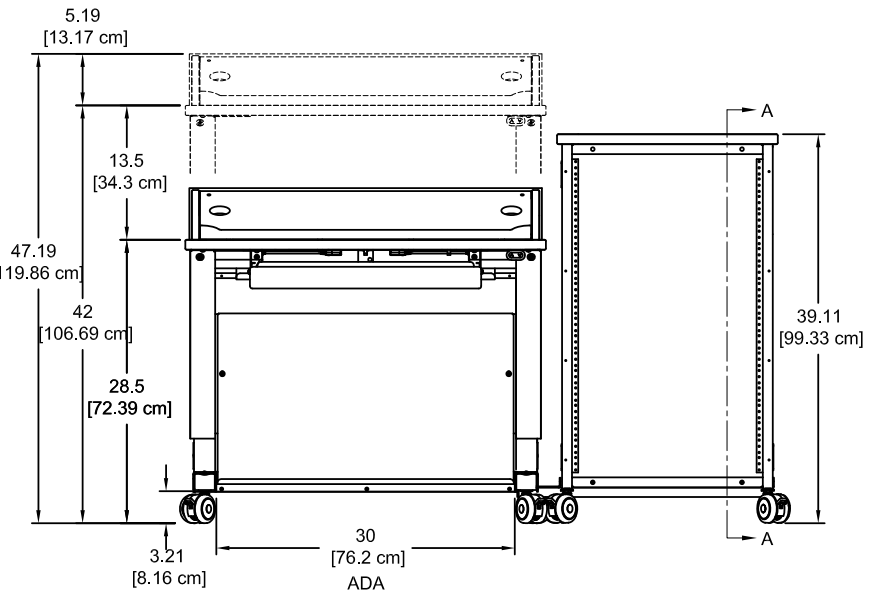
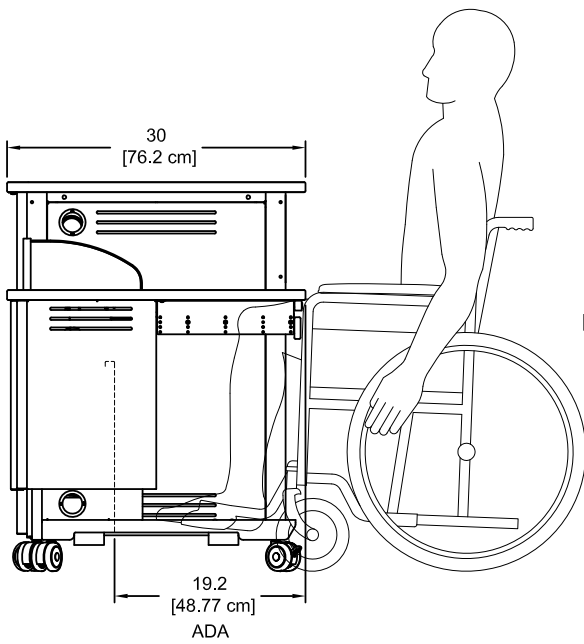
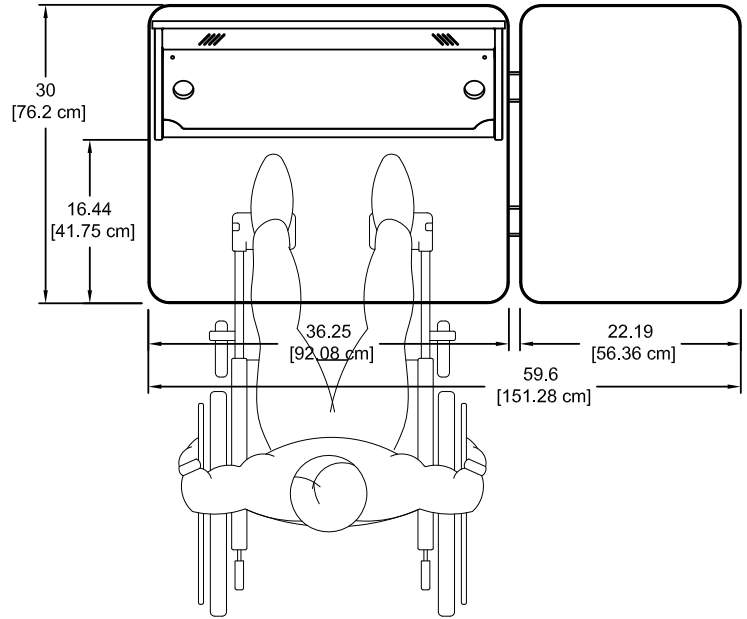
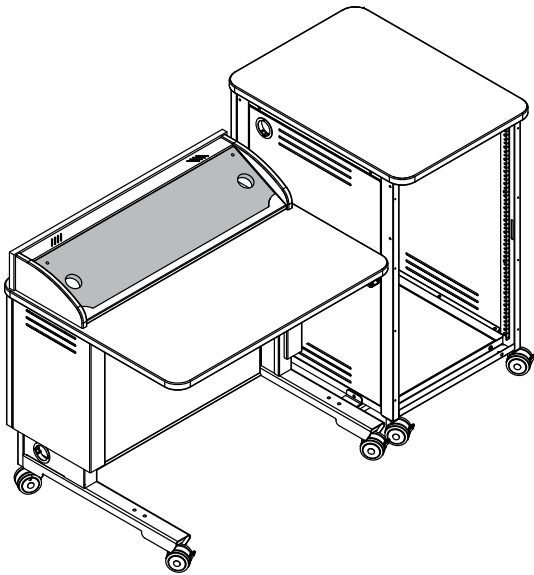

Equipment Rack  
Section View A-A

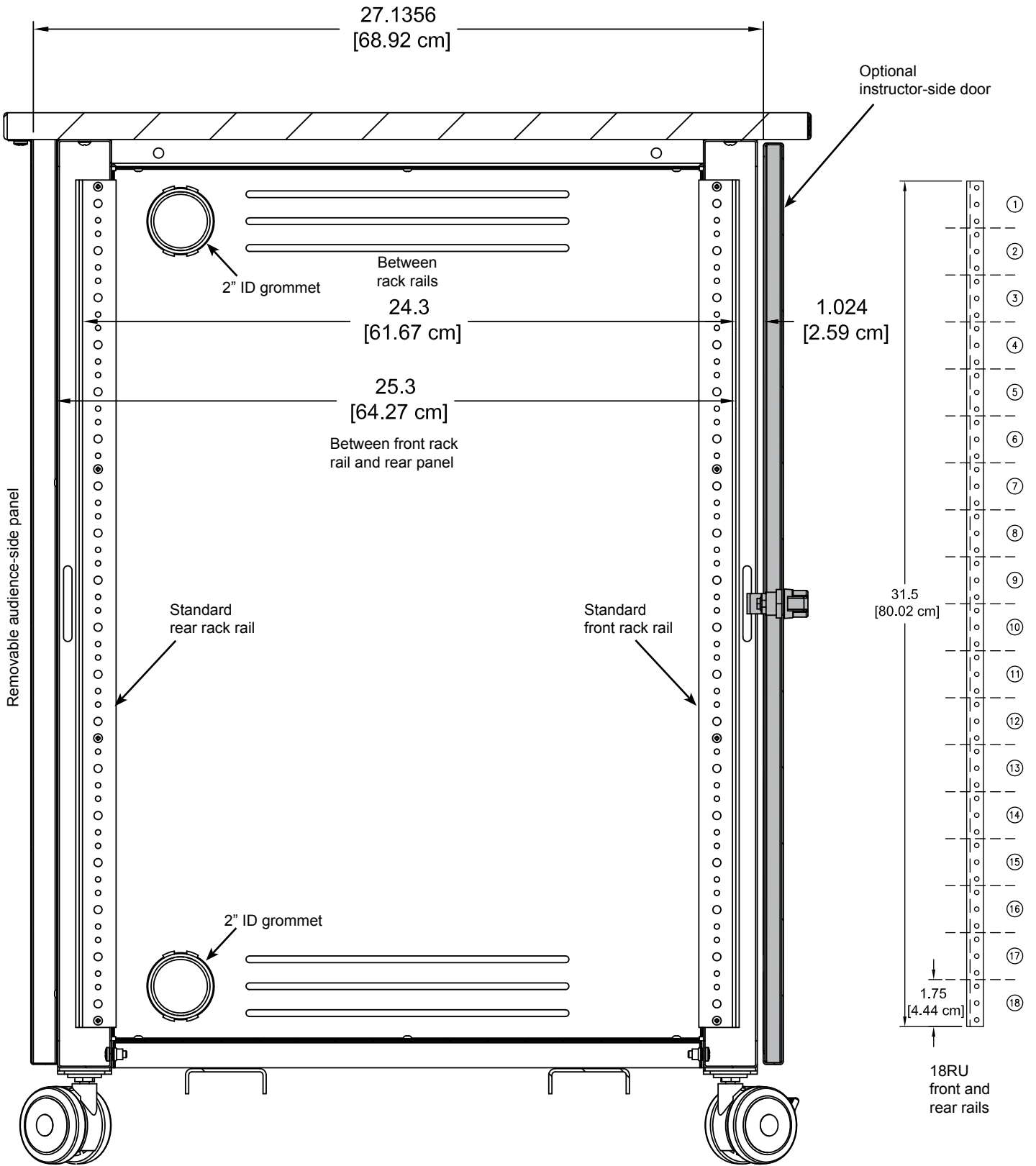

Note: The audience-side of the rack can be accessed by removing 2 screws securing the audience-side panel.

Note: Modified worksurface cutouts should be reviewed by Spectrum to ensure clearance of brackets, keyboard slides, or other objects under the worksurface.  
 Contact Spectrum to specify cutout size(s) and location(s).

Possible Cutout Areas (shown shaded) in lectern with surround  
 Top View

Possible Cutout Area (shown shaded) in Equipment Rack  
 Top View

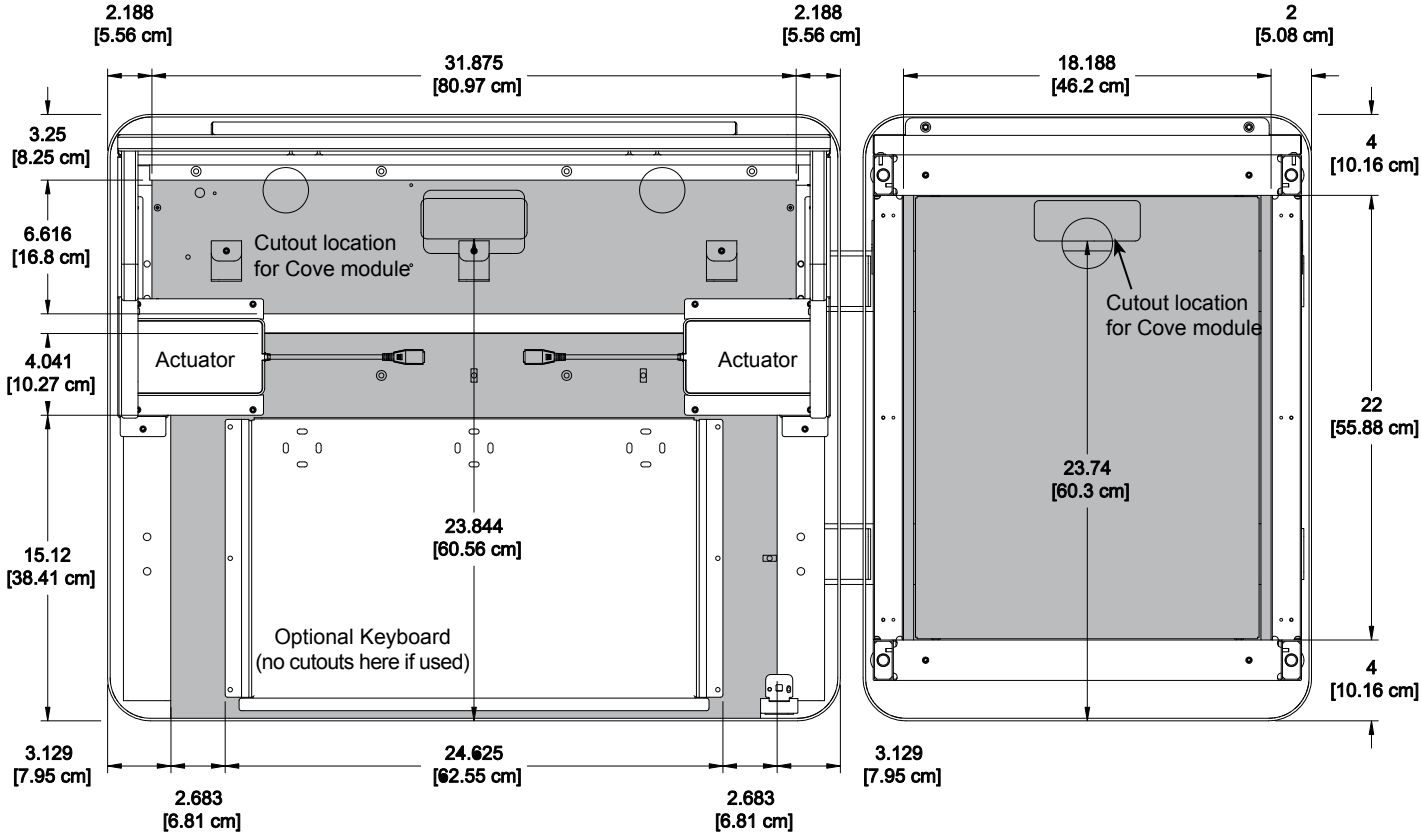

Freedom One eLift Overbridge Insert Panel Blank  
(flat view)

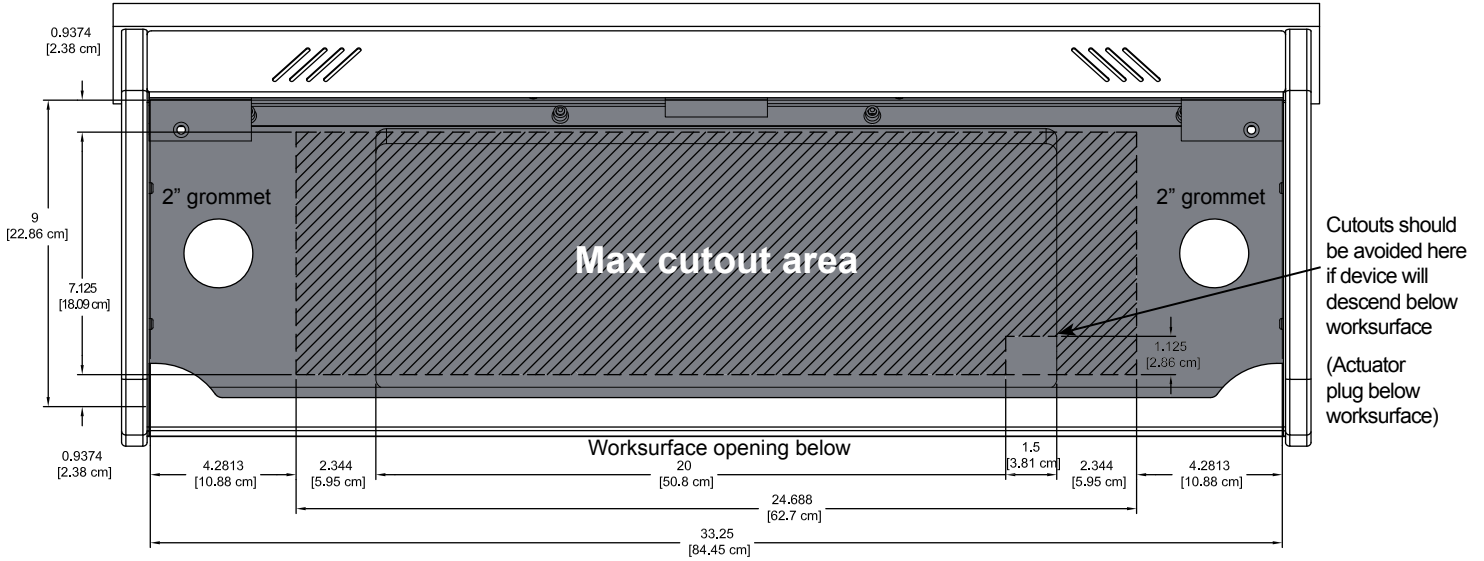

Overbridge section view

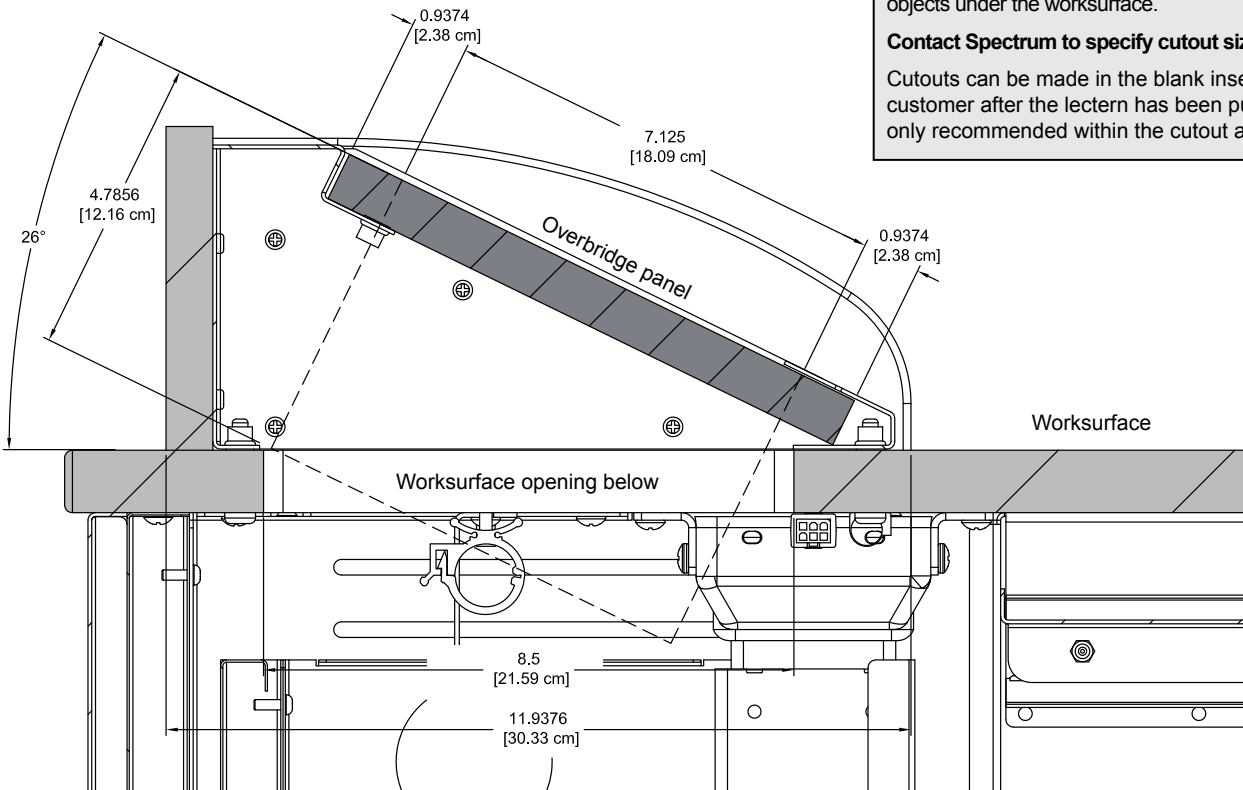

Note: The Overbridge Control Console™ has been designed for many of the currently available controllers on the market, however, modified cutouts should be reviewed by Spectrum to ensure clearance of brackets, keyboard slides, or other objects under the worksurface.

**Contact Spectrum to specify cutout size(s) and location(s).**

Cutouts can be made in the blank insert panel by the customer after the lectern has been purchased, but are only recommended within the cutout area shown.

## Accessories (Available separately after initial configured purchase.)

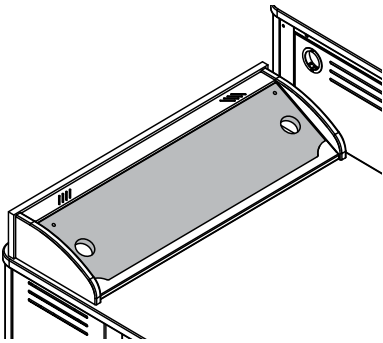

### Overbridge Insert Panel Blank - 96507 Overbridge Insert Panel with cutout(s) - 96507mod

- Panel for overbridge version only (overbridge not available separately)
- Contact Spectrum to specify cutout size(s) and position(s)
- Includes two 2" [5.08 cm] grommets with covers
- Customer-installed

Dimensions: 33.25"W [84.45 cm] x 9"D [22.86 cm]  
Shipping weight: 8.5 lb [4.1 kg]

The 96507 Insert Panel is available to customers needing a replacement panel or different cutouts for technology upgrades.

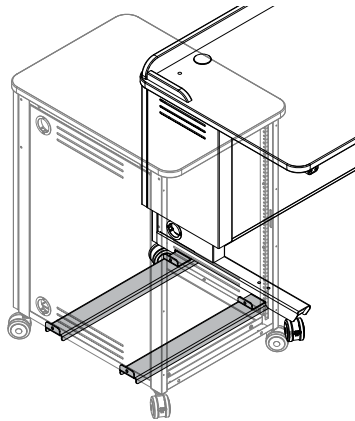

### Unit-to-Unit Connector Kit - 55359

- For connecting equipment rack to lectern
- Simple installation-lectern and equipment rack can remain right-side up
- Shipping weight: 9 lb [3.9 kg]

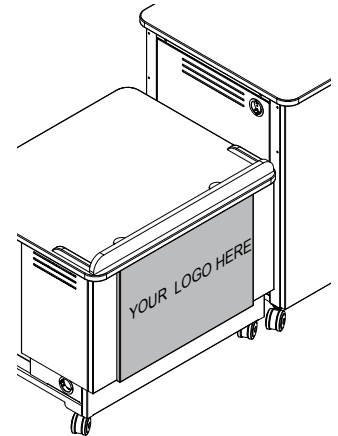

### Customized Logo Panel - 55380

- To get a customized logo panel, contact Spectrum to specify all logo details
- New logos require a first time logo charge

Dimensions: 26"W [66 cm] x .625"D [1.6 cm] 19.09"H [48.5 cm]  
Shipping weight: 15 lb [6.8 kg]

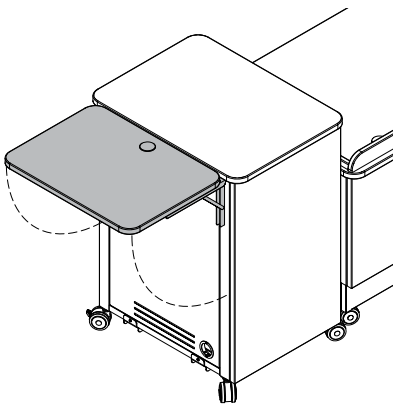

### Flip-up Shelf - 55378

- Includes 2" grommet

Dimensions: 21.1875"W [53.8 cm] x 30"D [76.2 cm] x 1"H [2.54 cm]  
Weight capacity: 35 lb [15.9 kg]  
Shipping weight: 15 lb [6.8 kg]

Note: Not recommended for use on stand-alone equipment racks.

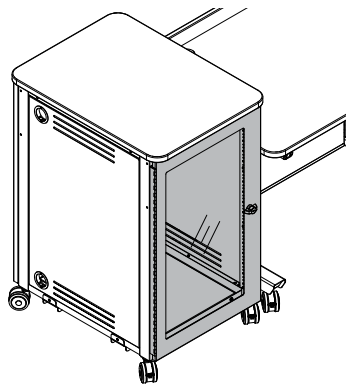

### Clear Acrylic Door - 68153

- Locking
- For instructor-side installation
- Can be installed to be hinged from the left or right side
- Shipping weight: 12.8 lb [5.8 kg]

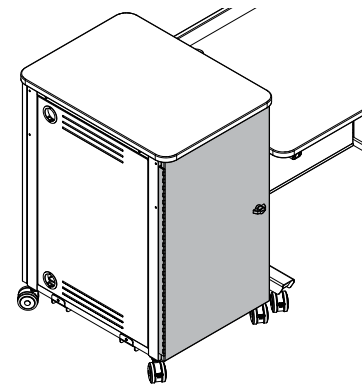

### Solid Door - 68152

- Locking
- For instructor or audience-side installation
- Can be installed to be hinged from the left or right side
- Shipping weight: 17.4 lb [7.9 kg]

Note: When used on the audience-side of the Freedom One eLift Lectern, 68152 will replace the standard audience-side panel.

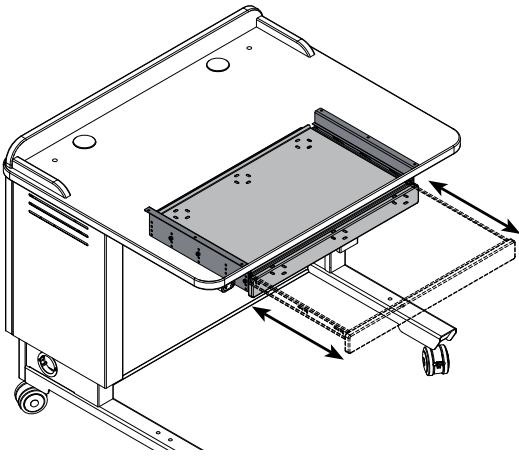

**Keyboard Tray - 55379**

- Tray can be installed and used as a keyboard tray or flipped and used as a storage drawer using pre-drilled mounting holes under the lectern worksurface.
- Wire management slots in tray

Dimensions: 22"W [55.9 cm] x 13.815"D [35.1 cm] x 4"H [10.2 cm]  
 Weight capacity: 25 lb [11.4 kg]  
 Shipping weight: 14 lb [5.4 kg]

Note: The keyboard tray protrudes 3.4375" [8.73 cm] below the worksurface. If the lectern is used for ADA use, a higher adjusted worksurface (around 32"H) is necessary to provide wheelchair clearance.

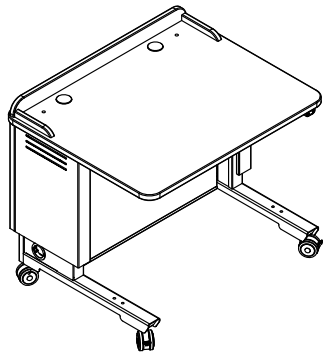

**Freedom One eLift Lectern - 55357**

- Electrically-adjustable worksurface
- ADA-compliant
- Available in surround or overbridge versions
- Factory-assembled with casters or glides

Lectern Style:      • Surround  
                              • Overbridge  
 Worksurface options: • No Cutouts  
                              • Custom Cutouts  
 Base options:        • Twin Wheel Casters  
                              • Glides  
 Shipping weight:    151 lb [68.6 kg]  
 (nominal)

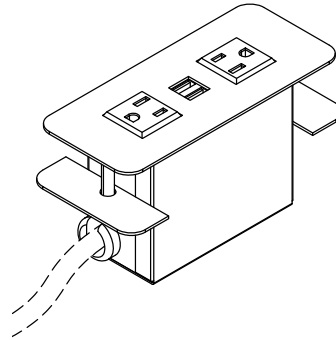

**Cove™ Power Module - 99044**

- Two power receptacles
- Two USB charge ports (not data-compatible)
- Thumbscrew clamps
- Requires worksurface cutout
- ETL listed
- Available in Black or Silver
- Customer-installed

Cutout required: 5.25"W [13.3 cm] x 2"D [5.1 cm]  
 Power cord: 9' [274 cm] with 90° flat plug with 45° rotation  
 Power receptacles: 12A, 120 VAC spill-resistant  
 USB charging ports: 2.1A (10.5W)  
 Dimensions: 6"W [15.2 cm] x 2.5"D [6.35 cm] x 3.18"H [8.1 cm]  
 Unit weight: 2 lb [.9 kg]  
 Shipping weight: 2.29 lb [1 kg]

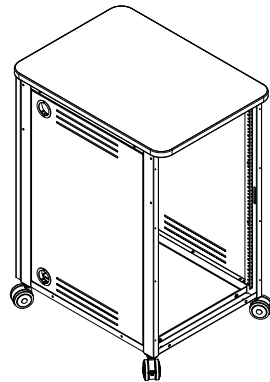

**Equipment Rack for Freedom One eLift - 55358**

- Rack rail: 18RU
- Front and rear rack rails
- Standard audience-side panel included
- Casters/glides assembled by customer
- 39.11"H [99.3 cm] worksurface height (with casters)
- Two 2" grommets in each side panel provide cord access
- One equipment rack can be attached to the left and right sides of the lectern

Worksurface options: • No Cutouts  
                              • Custom Cutouts  
                              • Cove Power Module  
 Base options:        • Twin Wheel Casters  
                              • Glides  
 Door options:        • Solid door  
                              • Acrylic door  
 Shipping weight:    116 lb [52.7 kg]  
 (nominal)

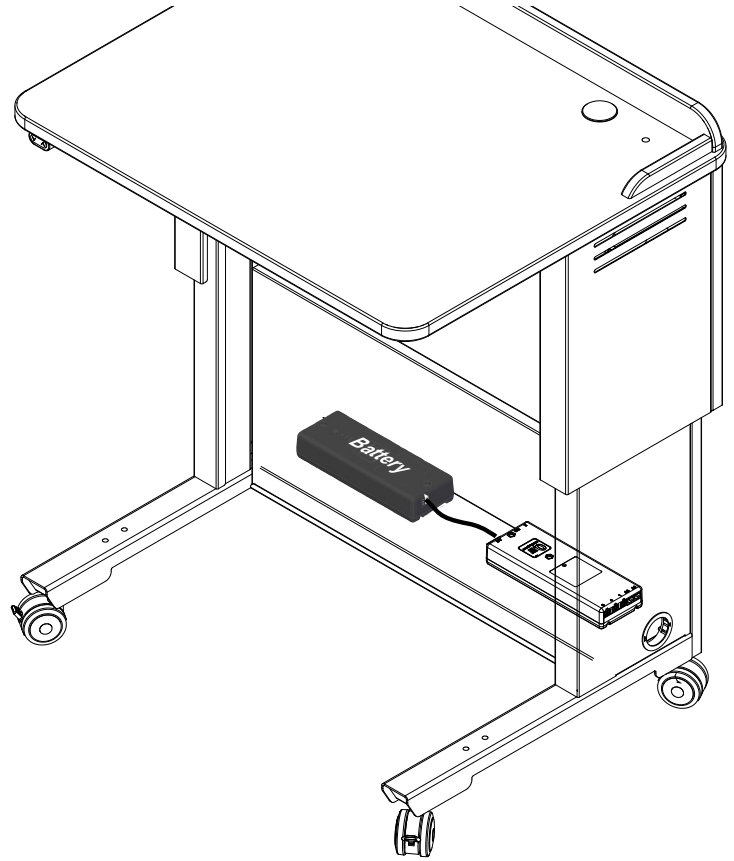

### Rechargeable Battery Pack System - 99045

- Creates a mobile lectern / desk by providing the ability to operate the unit in locations without AC power
- Compact, lightweight lithium-ion battery plugs into and charges from the existing lectern control box
- On-board LED light bars indicate charge capacity level
- Audio alarm signals when charging is needed
- Thermal switch protection, overcurrent protection
- Easy customer-installation

Battery Type	Lithium-ion
Capacity	2.2 Ah / 53 Wh
Voltage (nominal)	24V
Discharge current	9A (max)
Max charging voltage	40V DC
Charging current	0.5 A
Certifications	EN 62133 (Battery safety testing) UL 1642 (Lithium cells, standard test) UN 38.3 (Transportation of Lithium batteries) UL 2054 (Household and commercial batteries) EN 60335-1 with CBH Advanced
Unit weight: (nominal)	1.32 lb [.6 kg]
Shipping weight: (nominal)	2 lb [.9 kg]

#### Battery / Control Box Compatibility:

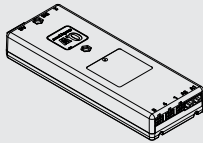

The CBD6S Linak control box is compatible with this battery pack.



Older CBD4 Linak control boxes are not compatible with this battery pack.

# Warranty

## **WE WILL MAKE IT RIGHT FOR YOU!**

Spectrum is committed to provide complete customer satisfaction. Each of our products is manufactured from the best materials available and each product is stringently monitored throughout the production process through our P.A.C.E. program (Product Assurance to meet Customer Expectations).

We expressly warrant that Spectrum products will be of good quality and workmanship and free from defect for the period set out in the warranty table below from the date of delivery. This warranty shall not apply to defects or damage resulting from misuse, abuse, neglect, improper care, modification or repair not authorized by Spectrum, or any other cause outside the control of Spectrum. Spectrum will, at its sole option, either repair or replace the defective product.

This warranty is exclusive; no other warranty, written or oral, is expressed or implied. This warranty is given by Spectrum to Buyer and to no other person or legal entity. No Spectrum dealer, distributor, agent or employee is authorized to make any modification or addition to this warranty.

**NOTWITHSTANDING ANYTHING TO THE CONTRARY, SPECTRUM WILL NOT UNDER ANY CIRCUMSTANCES BE LIABLE FOR INDIRECT OR LIQUIDATED DAMAGES, INCLUDING CONSEQUENTIAL, INCIDENTAL AND SPECIAL DAMAGES. IN NO EVENT SHALL SPECTRUM'S LIABILITY, WHETHER UNDER CONTRACT OR WARRANTY, IN TORT OR OTHERWISE, EXCEED THE PURCHASE PRICE RECEIVED BY SPECTRUM FOR THE PRODUCT AT ISSUE AND "RECALL ACTION" EXPENSES. SPECTRUM SHALL NOT BE SUBJECT TO ANY OTHER OBLIGATIONS OR LIABILITIES, WHETHER ARISING OUT OF BREACH OF CONTRACT, WARRANTY, TORT (INCLUDING NEGLIGENCE AND STRICT LIABILITY) OR OTHER THEORIES OF LAW, WITH RESPECT TO PRODUCTS SOLD OR SERVICES RENDERED BY SPECTRUM, OR ANY UNDERTAKINGS, ACTS OR OMISSIONS RELATING THERETO.**

Our Customer Service Department is ready to provide immediate attention to any questions, comments or concerns. They are available to answer your calls Monday through Friday from 7 am to 5 pm CST. In addition your product comments or concerns are welcome via e-mail at: [spectrum@spectrumfurniture.com](mailto:spectrum@spectrumfurniture.com).

Warranty Table

Item	Warranty Period effective 1/1/2015
Adjustable Crank / Electric Desk Legs	• 1 Year
Flat Panel Desk Gas Cylinders	
Chairs <ul style="list-style-type: none"> <li>• Adjustable Height Chair Parts – including frames, gas cylinders, wood and plastic parts, control handles, casters</li> <li>• Adjustable Height Chair Upholstery</li> <li>• In-Stock Upholstery</li> <li>• Graded-In Fabrics and Customer Owned Material</li> </ul>	<ul style="list-style-type: none"> <li>• 7 Years</li> <li>• 2 Years</li> <li>• 2 Years</li> <li>• No Warranty</li> </ul>
Height Adjustable Columns and Lifts	• 1 Year
General Use Casters	
Electrical (including timers and LINAK actuators)	• 2 Years
Keyboard / Mouse Trays	• 1 Year
Flat Panel Monitor Arms <ul style="list-style-type: none"> <li>• Flat Panel Monitor Arm – General Parts</li> <li>• Flat Panel Monitor Arm – Gas Cylinders</li> </ul>	<ul style="list-style-type: none"> <li>• 5 Years</li> <li>• 2 Years</li> </ul>
Desks and Lecterns <ul style="list-style-type: none"> <li>• Computer Desk Chassis</li> <li>• Cart Chassis</li> <li>• Lectern Chassis</li> </ul>	• 10 Years

