

Technical Specifications

55431	IT-16 Cabinet with power strips
55430	IT-16 Cabinet-no power strips

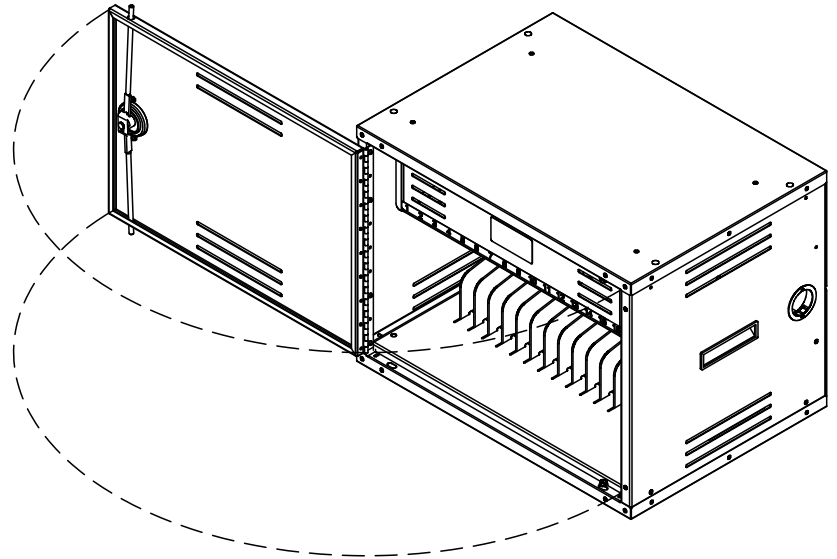
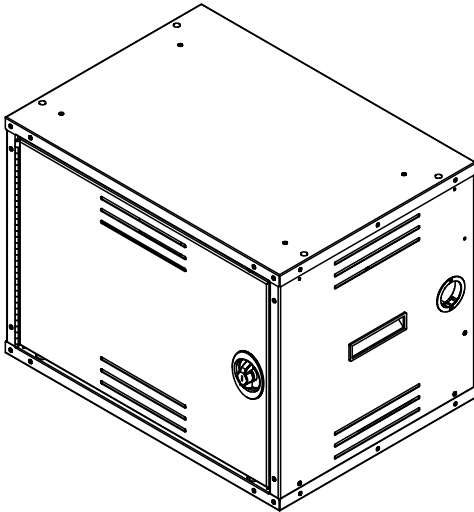

205 Westwood Ave, Long Branch, NJ 07740
 Phone: 866-94 BOARDS (26273) / (732)-222-1511
 Fax: (732)-222-7088 | E-mail: sales@touchboards.com

Use the InTouch16 Cabinet to store and charge up to 16 computer devices (tablets, Chromebooks and laptops). Padded shelves and flexible dividers protect the computer devices. Overhead wire management in a pullout drawer aids wiring integration, and allows the charging plugs to hang in front of each computing device. The InTouch16 Cabinet's small footprint covers less counter space and can be stacked for additional computer device storage with no additional loss of counter space. The InTouch16 Cabinet is made with powder-coated steel for security and a durable and long-lasting finish. A dual-bolt lock on the door increases security of the computing device.

Features and Benefits

- Stores and charges up to 16 tablets / Chromebooks, or 8 full-size laptops
 - 1.25"W [3.18 cm] x 17.375"D [44.13 cm] x 12"H [30.48 cm] universal storage bay (2.5625"W [6.5 cm] with every other divider removed)
 - Durable ABS plastic dividers and shelf padding protect devices from scratching (dividers are removable to provide storage space for thicker devices)
 - Doors provide easy-access to tablet and power-side of cart (can be flipped to be hinged from the left or right)
 - Double bolt lock, keyed, heavy gauge steel door provides vault-like security for your investment
 - Power drawer provides easy-access to electrical power while keeping line voltage, wiring, and cords away from students
 - Superior, all-metal overhead cord management system keeps charge cords organized above each storage bay
 - Numbered storage bays keep tablets organized
-
- Two 8-outlet 120V power strips with 3550 joule surge suppressor and generous outlet spacing accommodate both inline and wall adapters (55431 only)
 - Version without power strips (55430) allows user to integrate with power strip of choice
 - Side grommets placed for effective cord management
 - Unit can be mounted to a worksurface for additional security
 - Ventilated doors and side panels keep Chromebooks and chargers cool, preventing overheating, and extending device life
-
- Cabinet ships fully-assembled for quick, simple integration and deployment
 - Durable powder coated steel chassis provides a long lasting finish
 - UL-listed power strips (55431 only)
 - SCS Indoor Advantage Certified, meets or exceeds applicable ANSI-BIFMA test standards
 - Warranted to be free of all defects in materials and workmanship for 10 years, electrical system 2 years
 - Assembled in Chippewa Falls, WI, USA



Color Options

Standard metal colors

Silver Sparkle
(S)



Standard color combination refers to the quickest deliverable product color combination. Custom laminates and color combinations are available—additional lead-times and up-charges may apply. Call 1-800-235-1262 for further information.

Construction

- Metal components consist of 16-gauge steel
- 16-gauge side panels, shelf, drawer, and door
- All metal components are finished with a scratch-resistant powder coat epoxy
- Each InTouch16 Cabinet is factory-assembled

Specifications

Capacity	16 tablets or Chromebooks 8 full-size laptops (every other divider can be removed to provide space for thicker laptops)	
Storage bays (nominal)	1.25"W [3.18 cm] (nominal) x 17.375"D [44.13 cm] x 12"H [30.48 cm] - 16 tablets 2.5625"W [6.5 cm] (nominal) x 17.375"D [44.13 cm] x 12"H [30.48 cm] - 8 full-size laptops - (every other divider removed)	
Stacking	Up to 3 high. Caution: Must be bolted together and top unit bolted to wall for stability.	
Power Drawer	20.5625"W [52.23 cm] x 16"D [40.64 cm] x 5.6875"H [14.45 cm] Power drawer isolates and separates electrical line voltage from students	
Electrical (power strip) (Two power strips included with 55431)	<ul style="list-style-type: none"> • 8 outlets with sliding safety covers • Continuous duty: 120V / 15A / 60Hz / 1800W • Surge protection: 3550 Joules • Overload protection • On/off switch • 6' [183 cm] nominal 14 AWG, 3-wire power cord with low-profile plug 	<ul style="list-style-type: none"> • Indicator lights • Detachable cord management system • Low-profile 1" thin • UL listed • A separate wall circuit is recommended for each power strip
Unit weight (nominal)	75 lb [34.1 kg]	
Shipping weight (nominal)	90 lb [40.9 kg]	

Specifications subject to change without notice

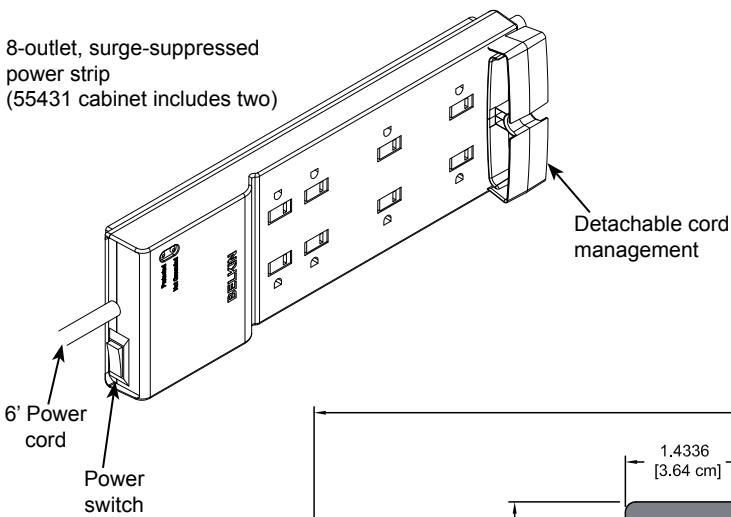

What's included:

- (2) 8-outlet power strips (55431 only)
- (4) Velcro® to attach power strips to the drawer
- (4) .375" [.952 cm] hole plugs for unused top mounting holes

Nominal outlet spacing on each 8-outlet power strip

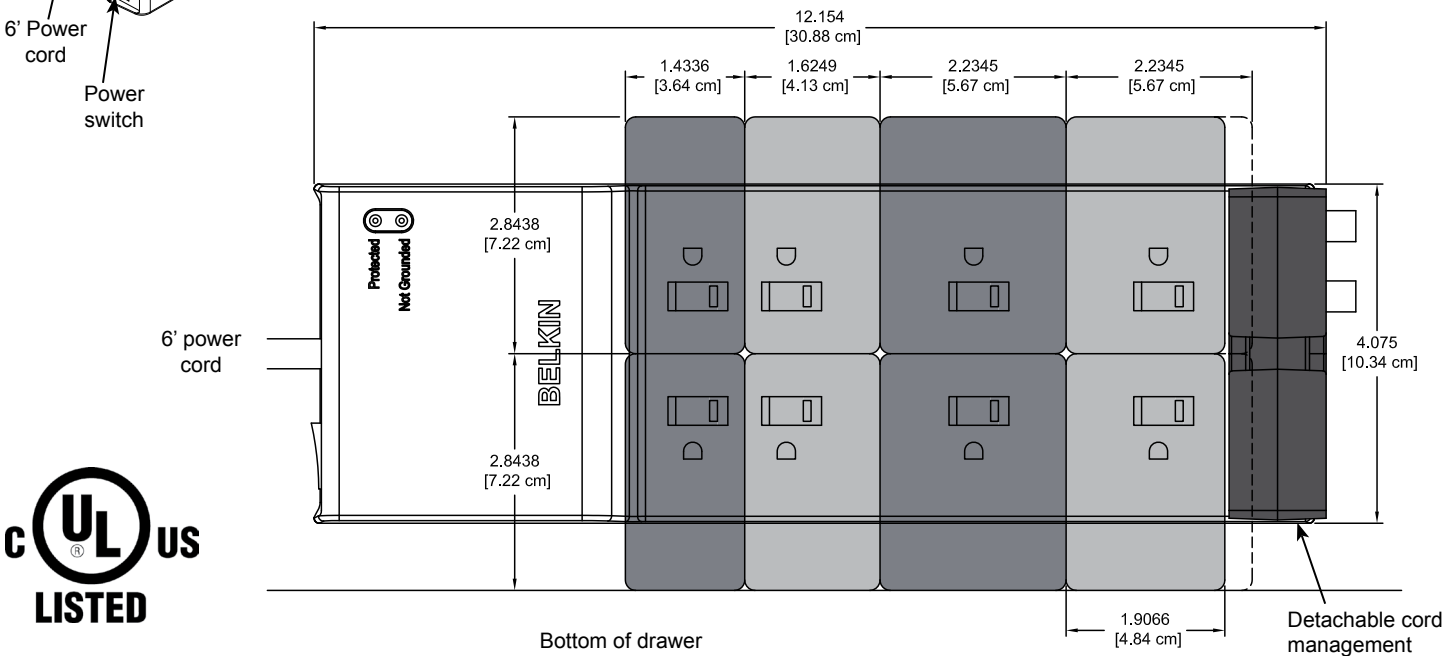

InTouch16 Cabinet

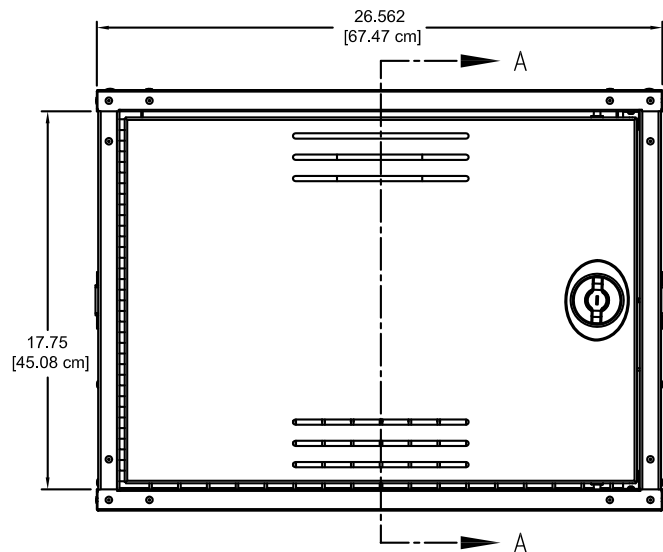
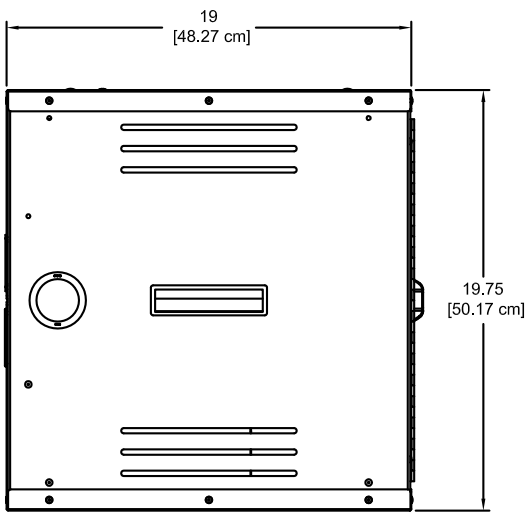
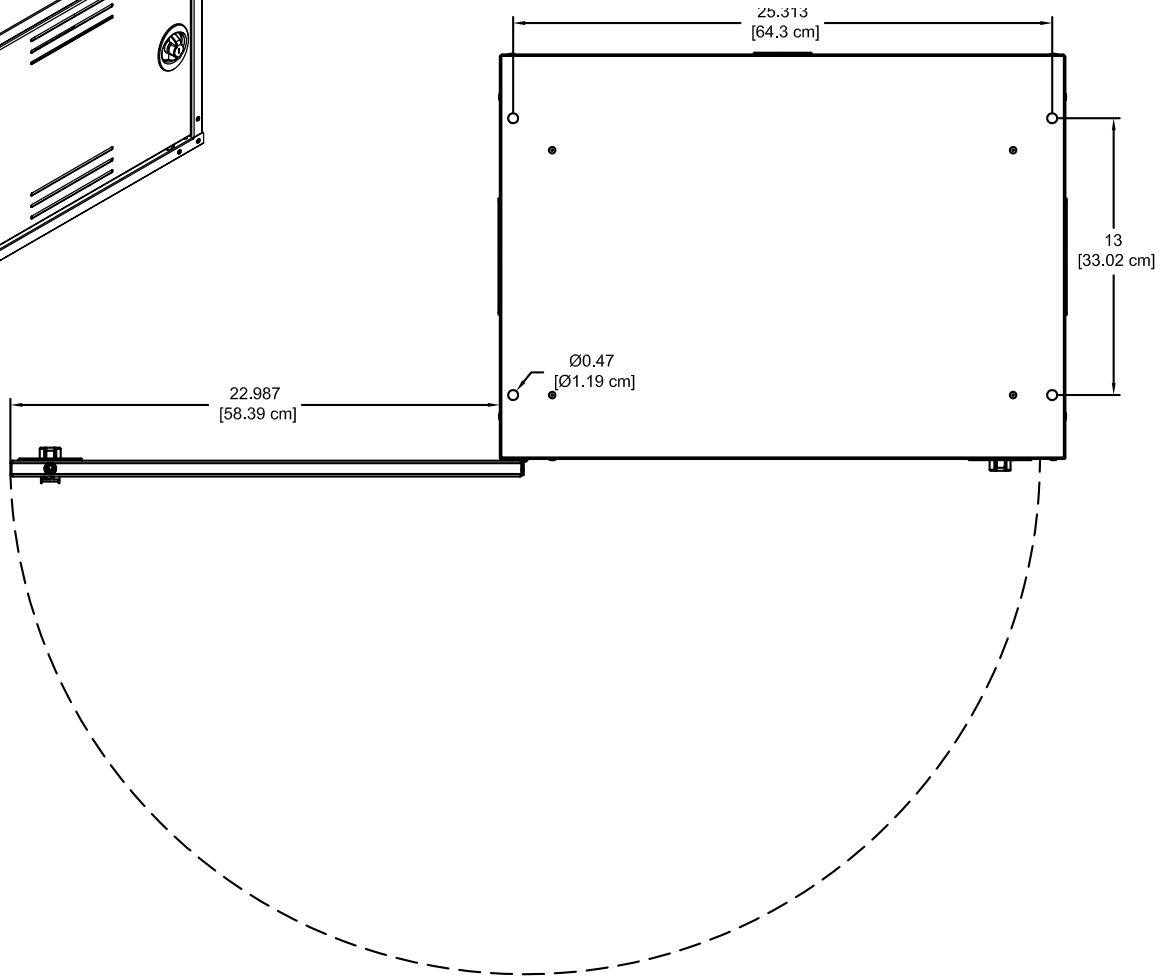
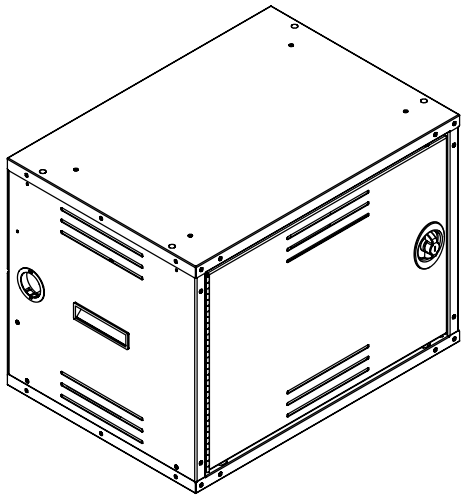

Section view

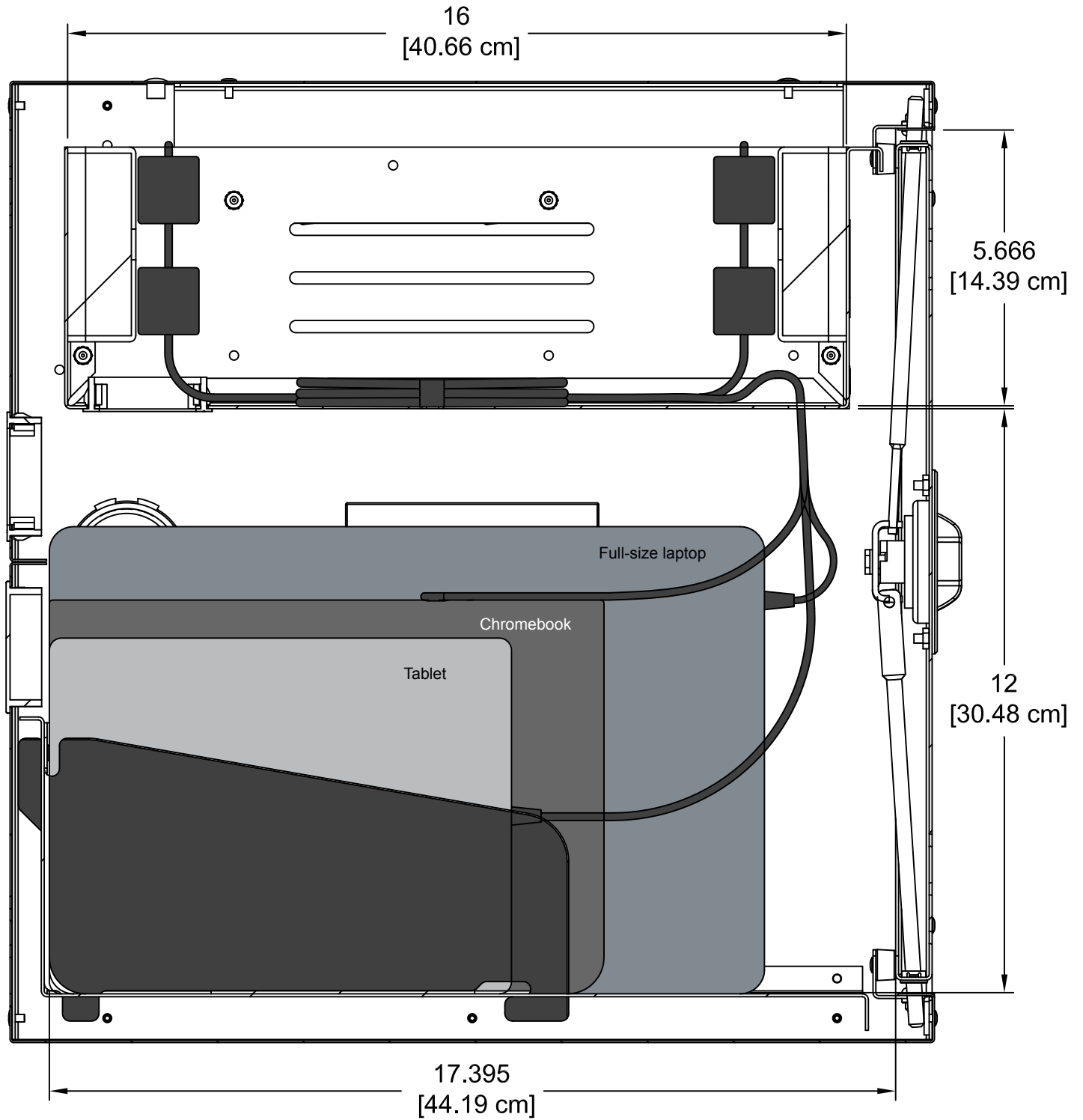

Front view with tablets
(shown without door)

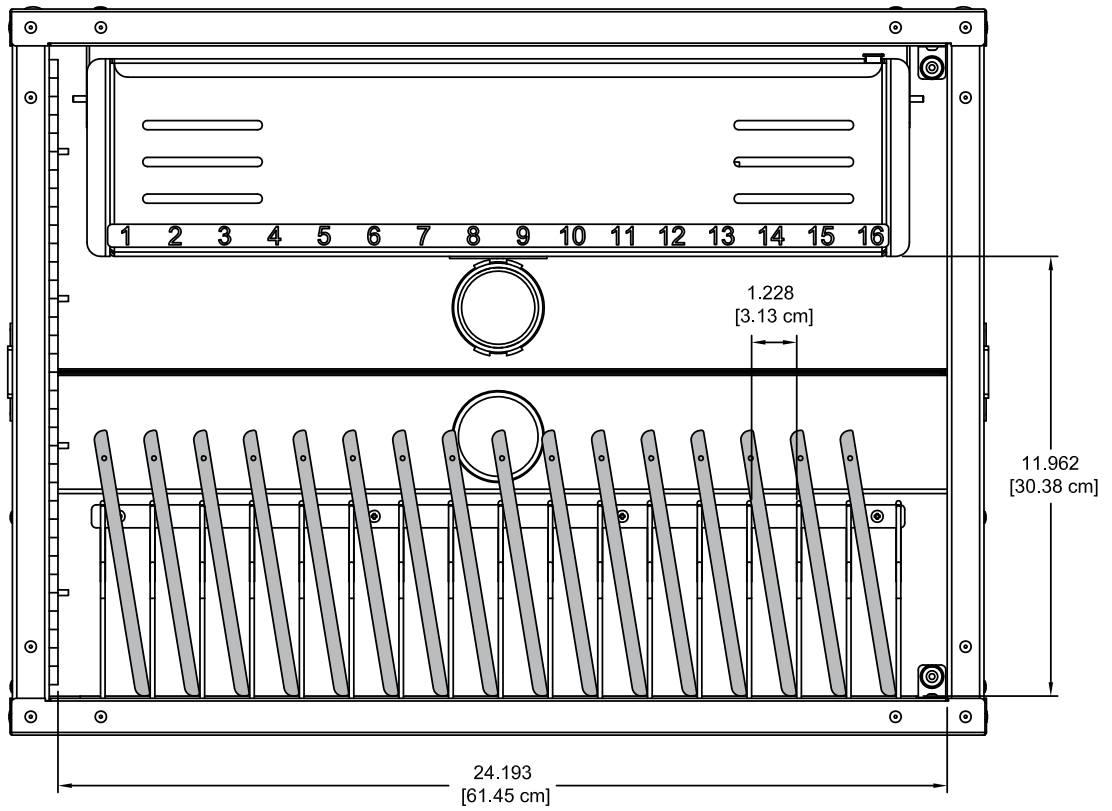

Front view with laptops
(8 dividers removed)
(shown without door)

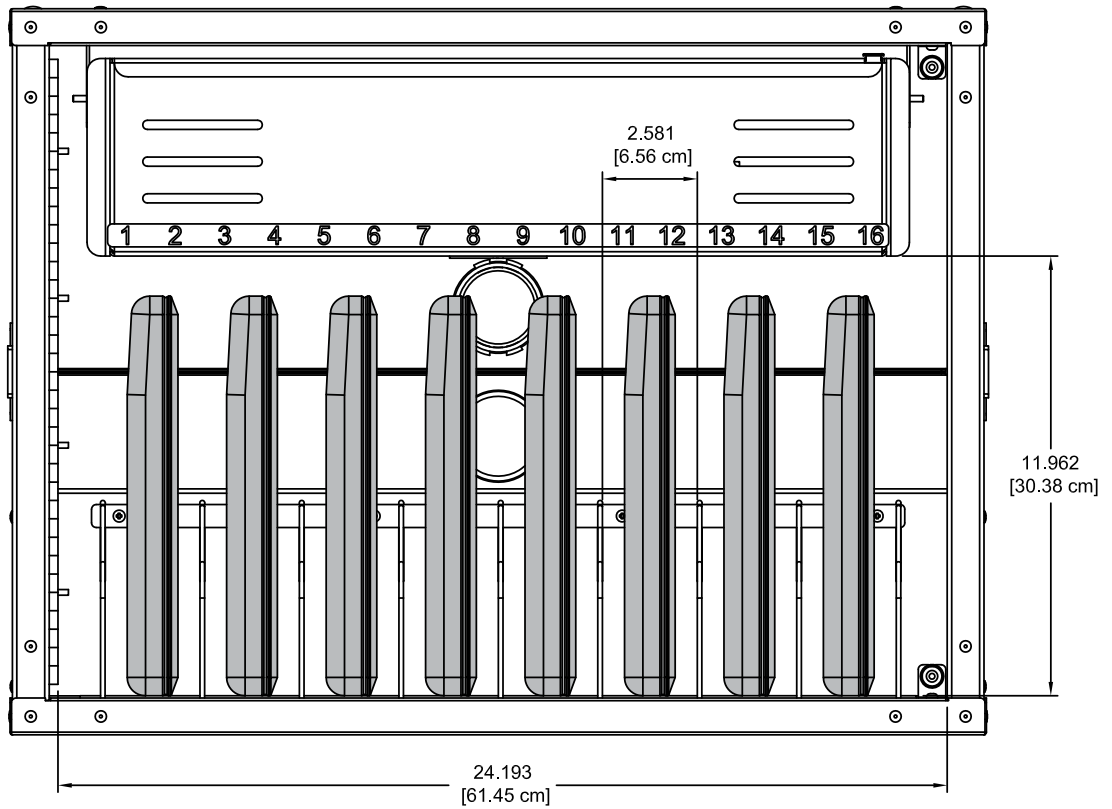

Internal drawer dimensions

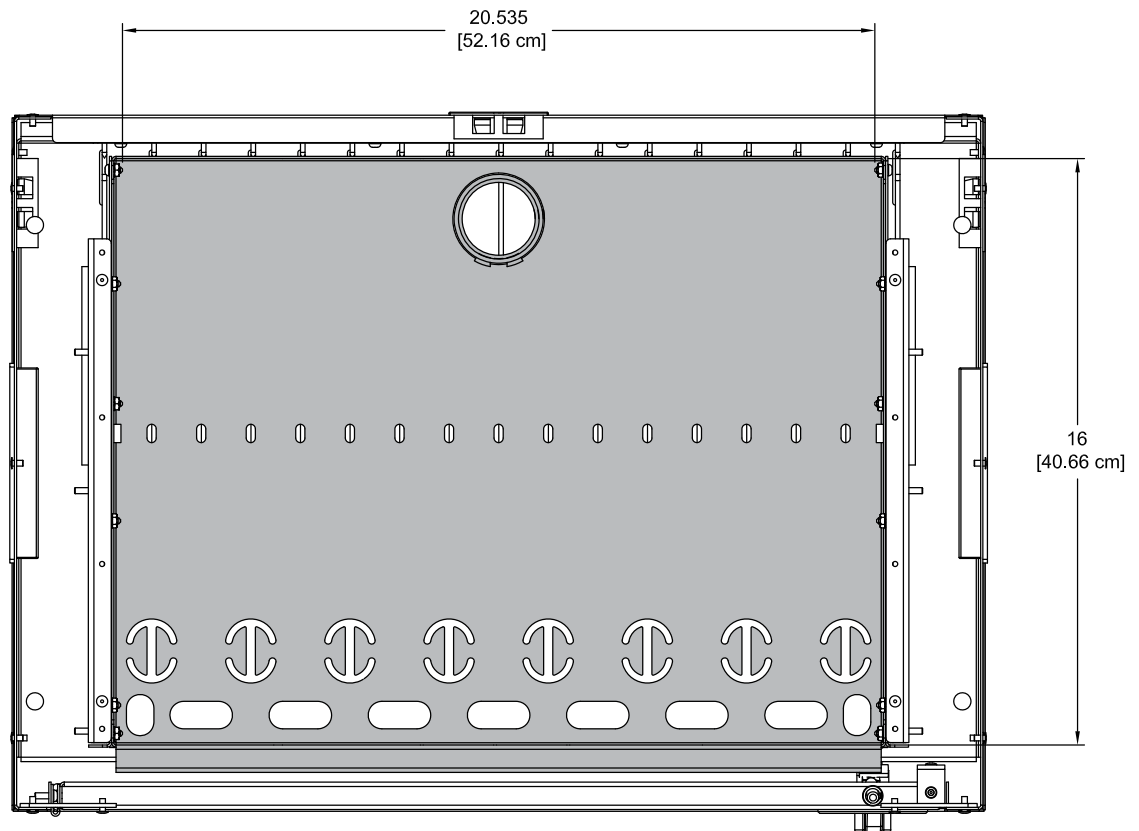
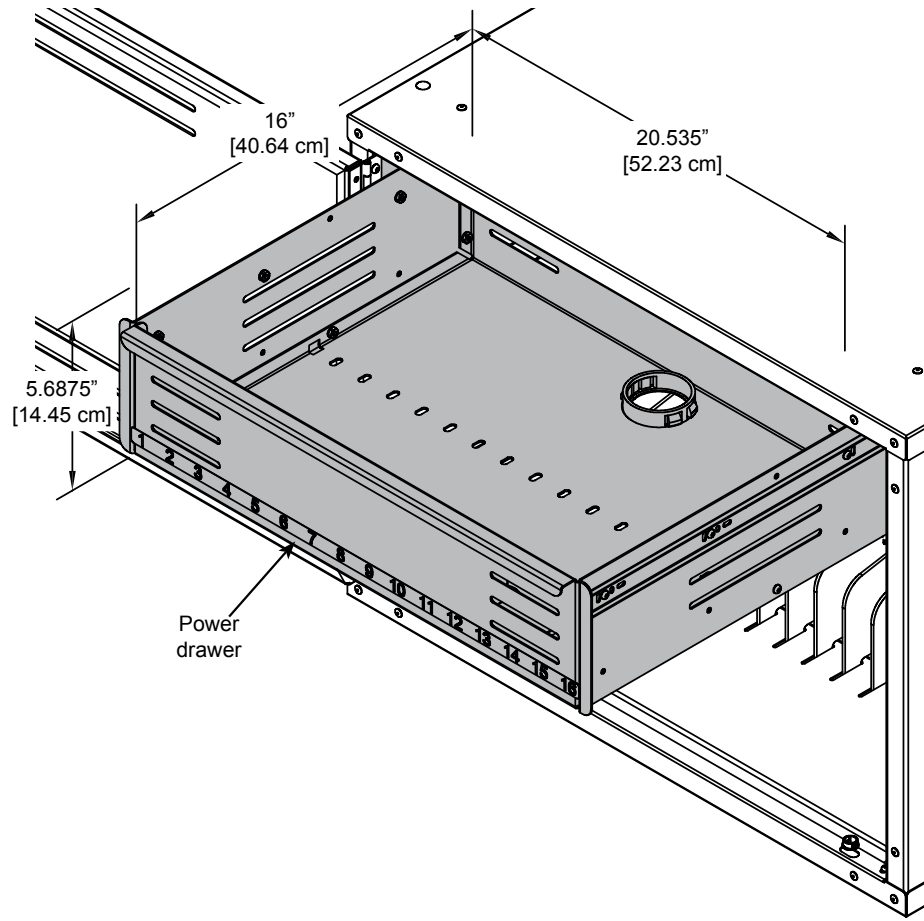

Power strip mounting options

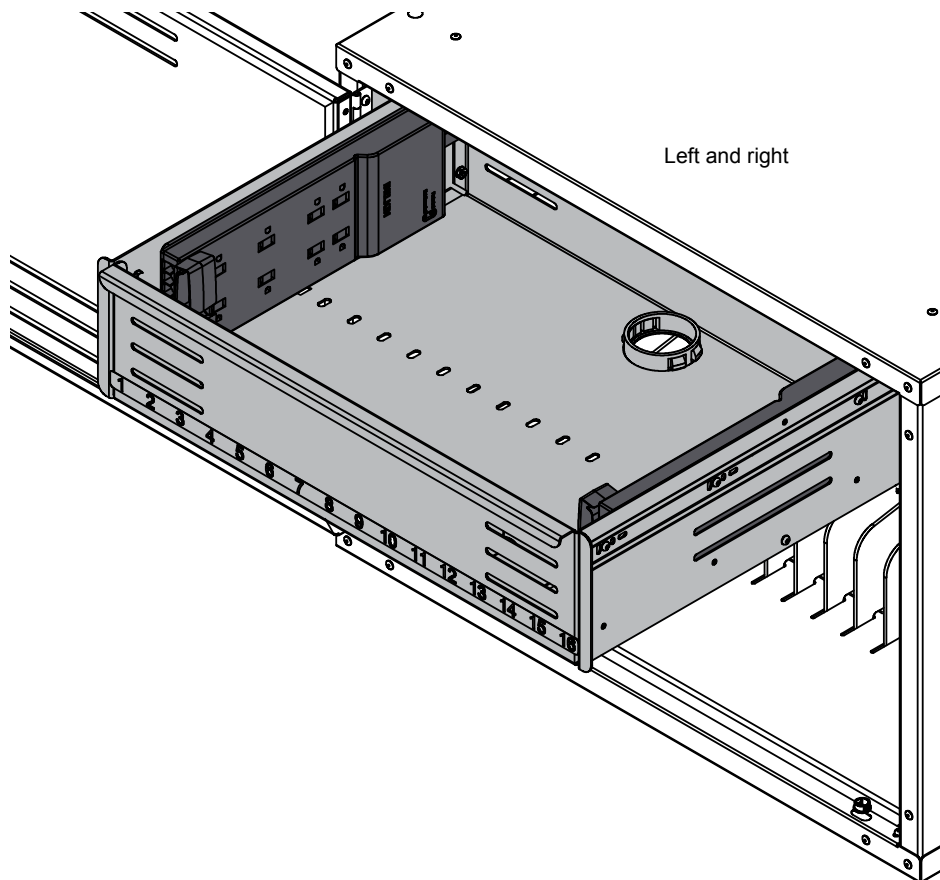
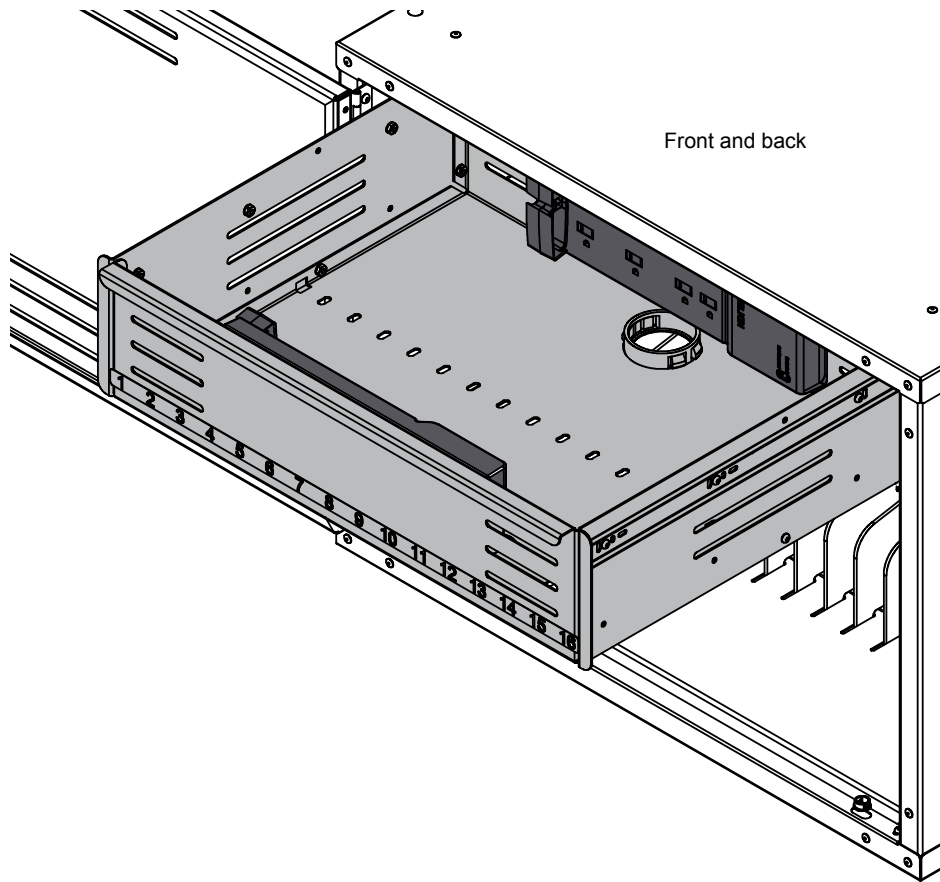

! WARNING !

THE INTOUCH 16 CABINET CAN BE STACKED ON A STABLE SURFACE (UP TO 3 HIGH). THE INTOUCH 16 CABINET IS NOT INTENDED OR DESIGNED TO BE INDIVIDUALLY HUNG ON A WALL.

WHEN STACKING, THE UNITS MUST BE STABILIZED USING THE .375" [.95 cm] MOUNTING HOLES IN THE BACK PANEL, AND BOLTED TOGETHER USING THE .5" [1.27 cm] MOUNTING HOLES IN THE TOP AND BOTTOM PANELS. FASTENERS ARE NOT INCLUDED.

IT IS THE CUSTOMER'S RESPONSIBILITY TO USE ADEQUATE FASTENERS DESIGNED FOR THE SPECIFIC WORKSURFACE, FLOOR, OR WALL TYPE THE UNIT WILL BE MOUNTED TO.

Note: The .375" [.95 cm] mounting holes located on the back panels are for stabilizing the unit(s) (up to 3 high only) and are 16" [40.64 cm] on-center to match most wall construction stud spacing. Be sure fasteners are anchored securely to studs or other solid portion of the wall.

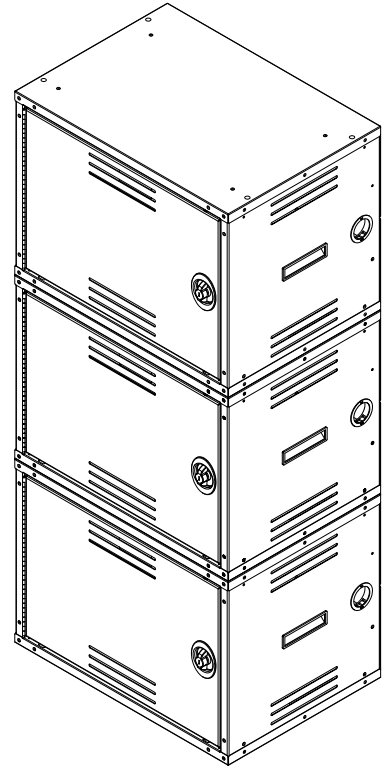

Back view

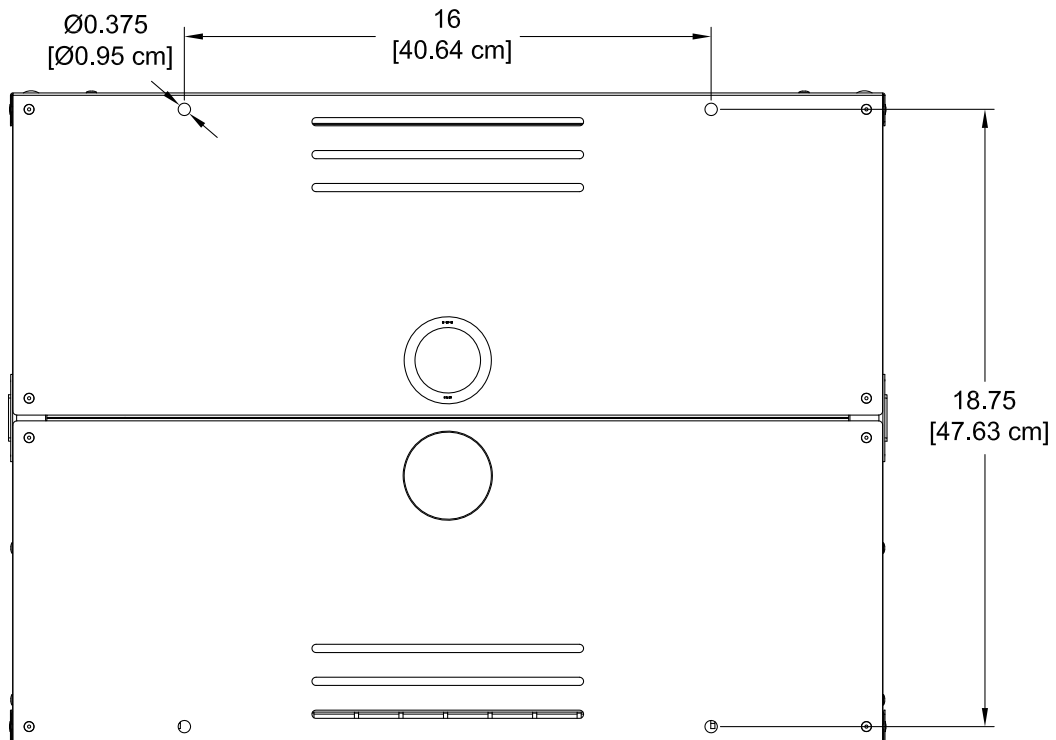

bottom view

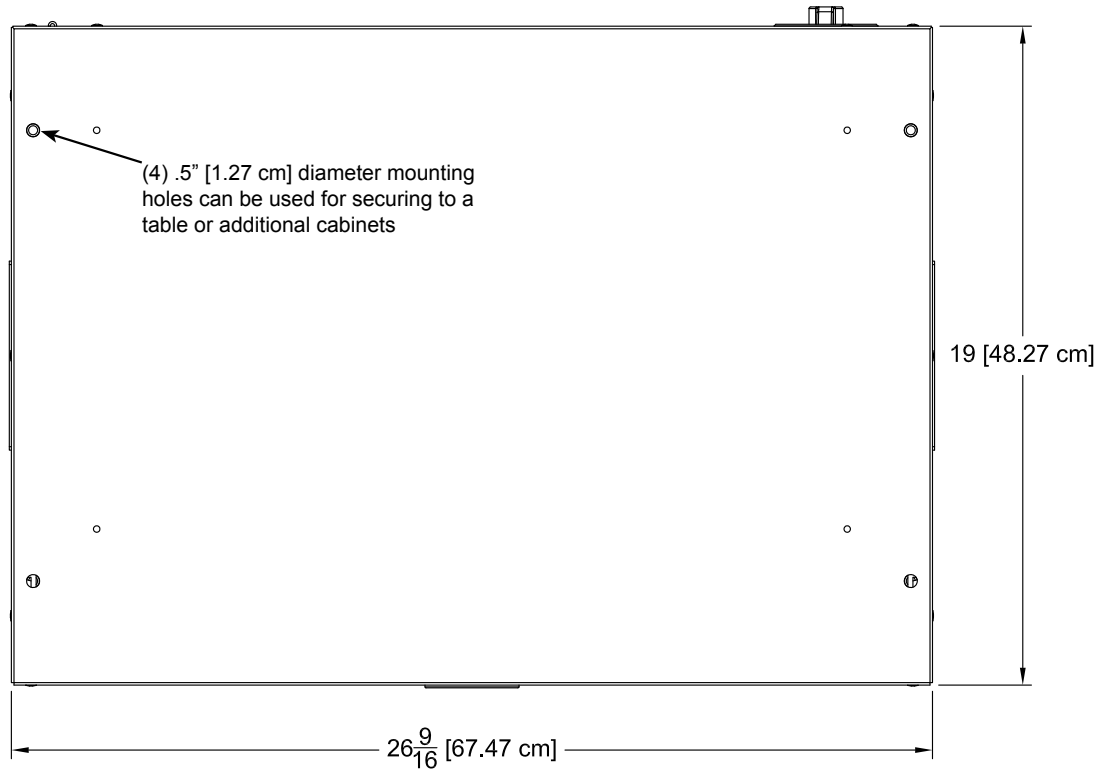

Options



Hook-and-loop Strap Kit - 95004

(16) .75" [1.91 cm] x 12" [30.48 cm],
and (32) .75" [1.91 cm] x 5" [12.7 cm]

Warranty

WE WILL MAKE IT RIGHT FOR YOU!

Spectrum is committed to provide complete customer satisfaction. Each of our products is manufactured from the best materials available and each product is stringently monitored throughout the production process through our P.A.C.E. program (Product Assurance to meet Customer Expectations).

We expressly warrant that Spectrum products will be of good quality and workmanship and free from defect for the period set out in the warranty table below from the date of delivery. This warranty shall not apply to defects or damage resulting from misuse, abuse, neglect, improper care, modification or repair not authorized by Spectrum, or any other cause outside the control of Spectrum. Spectrum will, at its sole option, either repair or replace the defective product.

This warranty is exclusive; no other warranty, written or oral, is expressed or implied. This warranty is given by Spectrum to Buyer and to no other person or legal entity. No Spectrum dealer, distributor, agent or employee is authorized to make any modification or addition to this warranty.

NOTWITHSTANDING ANYTHING TO THE CONTRARY, SPECTRUM WILL NOT UNDER ANY CIRCUMSTANCES BE LIABLE FOR INDIRECT OR LIQUIDATED DAMAGES, INCLUDING CONSEQUENTIAL, INCIDENTAL AND SPECIAL DAMAGES. IN NO EVENT SHALL SPECTRUM'S LIABILITY, WHETHER UNDER CONTRACT OR WARRANTY, IN TORT OR OTHERWISE, EXCEED THE PURCHASE PRICE RECEIVED BY SPECTRUM FOR THE PRODUCT AT ISSUE AND "RECALL ACTION" EXPENSES. SPECTRUM SHALL NOT BE SUBJECT TO ANY OTHER OBLIGATIONS OR LIABILITIES, WHETHER ARISING OUT OF BREACH OF CONTRACT, WARRANTY, TORT (INCLUDING NEGLIGENCE AND STRICT LIABILITY) OR OTHER THEORIES OF LAW, WITH RESPECT TO PRODUCTS SOLD OR SERVICES RENDERED BY SPECTRUM, OR ANY UNDERTAKINGS, ACTS OR OMISSIONS RELATING THERETO.

Our Customer Service Department is ready to provide immediate attention to any questions, comments or concerns. They are available to answer your calls Monday through Friday from 7 am to 5 pm CST. In addition your product comments or concerns are welcome via e-mail at: spectrum@spectrumfurniture.com.

Warranty Table

effective 1/1/2015

Item	Warranty Period
Adjustable Crank/Electric Desk Legs	• 1 Year
Flat Panel Desk Gas Cylinders	
Chairs <ul style="list-style-type: none"> • Adjustable Height Chair Parts – including frames, gas cylinders, wood and plastic parts, control handles, casters • Adjustable Height Chair Upholstery • In-Stock Upholstery • Graded-In Fabrics and Customer Owned Material 	<ul style="list-style-type: none"> • 7 Years • 2 Years • 2 Years • No Warranty
Height Adjustable Columns and Lifts	• 1 Year
General Use Casters	
Electrical	• 2 Years
Keyboard/Mouse Trays	• 1 Year
Flat Panel Monitor Arms <ul style="list-style-type: none"> • Flat Panel Monitor Arm – General Parts • Flat Panel Monitor Arm – Gas Cylinders 	<ul style="list-style-type: none"> • 5 Years • 2 Years
Desks and Lecterns <ul style="list-style-type: none"> • Computer Desk Chassis • Cart Chassis • Lectern Chassis 	• 10 Years



205 Westwood Ave, Long Branch, NJ 07740
 Phone: 866-94 BOARDS (26273) / (732)-222-1511
 Fax: (732)-222-7088 | E-mail: sales@touchboards.com

