

Technical Specifications

55447CW

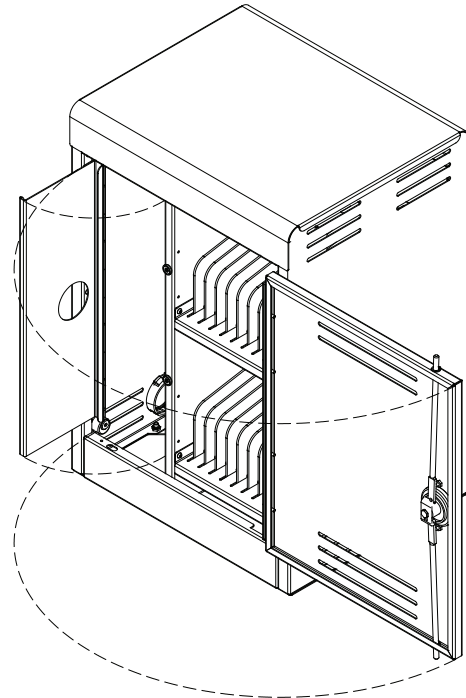
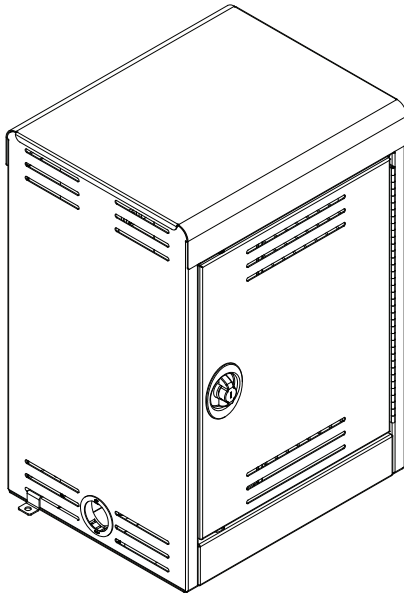

205 Westwood Ave, Long Branch, NJ 07740
 Phone: 866-94 BOARDS (26273) / (732)-222-1511
 Fax: (732)-222-7088 | E-mail: sales@touchboards.com

Spectrum's InTouch 20 Secure Tablet Locker is designed to store and recharge up to 20 tablet and/or iPad® style computers. It also has the ability to synchronize or image these devices with optional accessories easily installed in the field. The locker stores up to 20 computing devices up to 3/4" thick in individual vertical compartments with soft plastic dividers. A simple wire management shelf stores all line-voltage charging devices safely away from children, and a wire management system allows the low voltage charge cable to hang directly above each computer for easy student access.

Features and Benefits

- Manages up to 20 tablet computers (up to 3/4" thick)
- Easy-access to electrical power behind a separate teacher door keeps all line voltage, wiring, and cords away from students
- Superior cord management system keeps charge cords organized at each storage slot
- Numbered storage slots keep tablets organized
- Ample clearance is provided for easy removal and insertion of tablets
- Plastic dividers and padded bottom protect tablets from damage
- Cable grommets placed for effective cord management
- Security brackets allow unit to be mounted to worksurface for additional security
- Door and side panels are effectively ventilated to keep tablets cool
- Durable powder coated steel chassis provides a long lasting finish
- Double-bolt, keyed locking door provide security and easy-access
- Electrical system consists of UL-listed components
- One 20-outlet power unit with 15-amp breaker and reset button
- Power strip will accommodate a variety of large power plugs
- Cord management system keeps charge cords organized at each storage slot
- Optional synchronization kit provides the ability to "sync" tablets
- Warranted to be free of all defects in materials and workmanship with a 10-year warranty, electrical system 1-year

Options & Accessories

Page 5

Color Options

Standard metal colors

Cool White
(CW)



Standard color combination refers to the quickest deliverable product color combination. Custom laminates and color combinations are available-additional lead-times and up-charges may apply. Call 1-800-235-1262 for further information.

Construction

- Metal components consist of 16-gauge steel
- Vented side panels and door are made of 16-gauge steel
- All metal components are finished with a scratch-resistant powder coat epoxy
- Each InTouch 20 Secure Tablet Locker is factory-assembled

Specifications

Capacity	20 tablets
Storage slots	$\frac{3}{4}$ "W x $12\frac{3}{4}$ "D x $9\frac{1}{16}$ "H
Electrical	The locker has one power unit with 20 grounded 120V outlets with a 15-amp circuit breaker, on/off rocker switch, and 4' nominal, 3-wire, 14 AWG, UL-listed power cord
Optional Hubs	see specs on p.5
Unit weight (nominal)	76 lbs
Shipping weight (nominal)	78 lbs
Meets or exceeds applicable ANSI-BIFMA test standards	

Specifications subject to change without notice

teacher door
(provides wiring access)

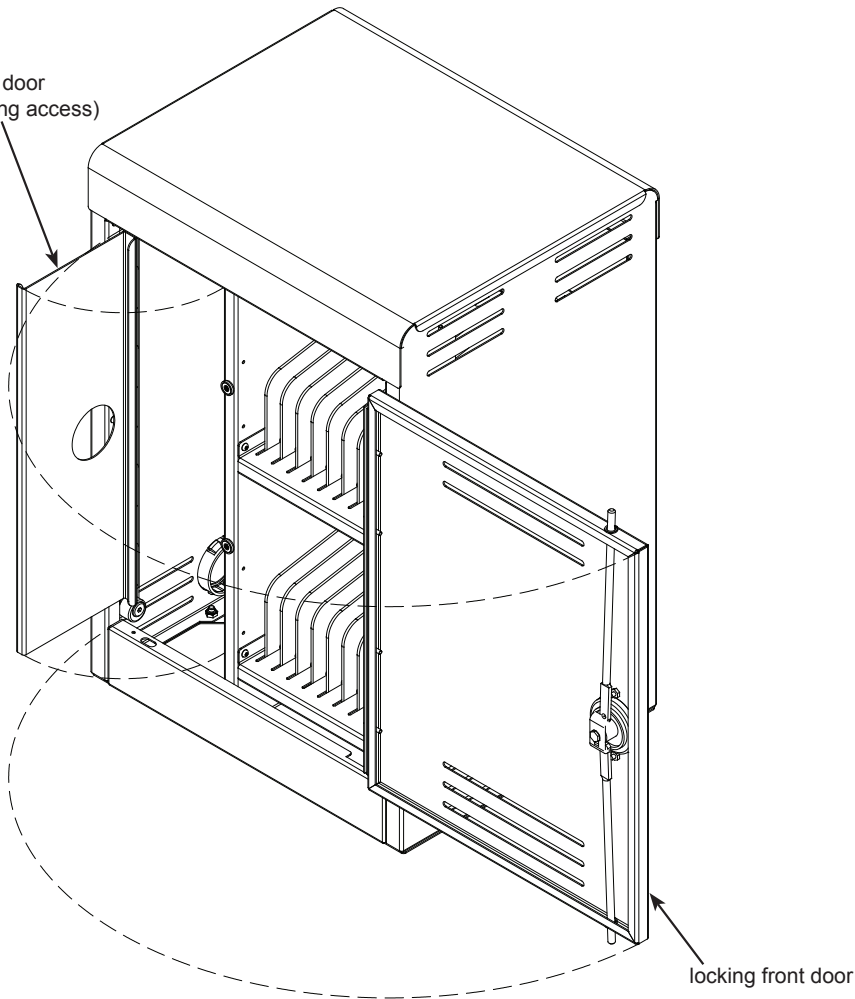

outlet spacing on each
20-outlet power unit

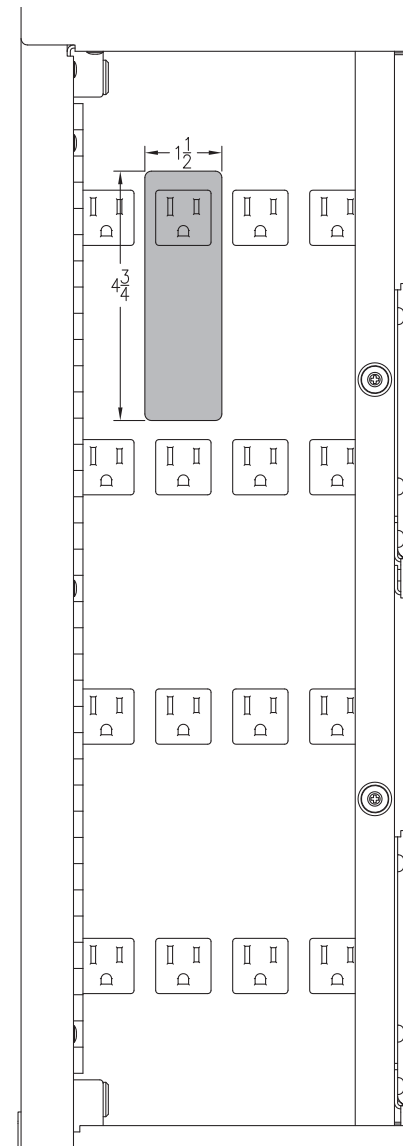

InTouch 20 Secure Laptop Locker

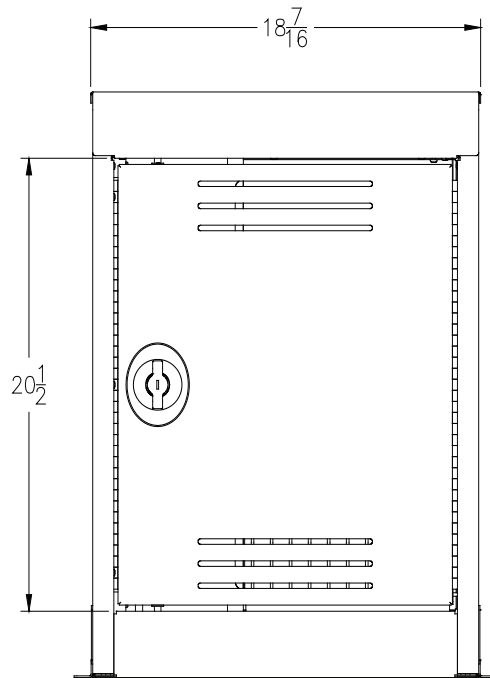
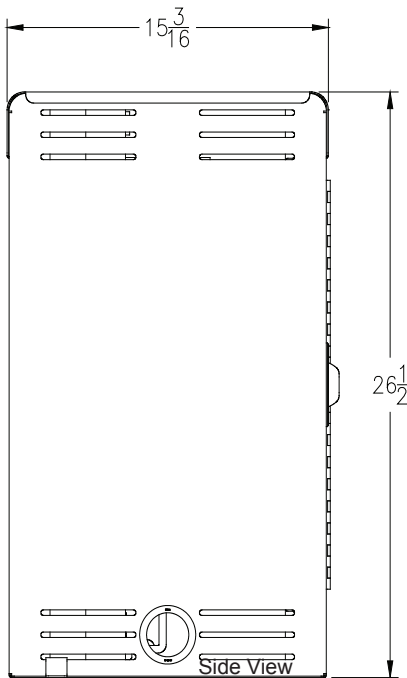
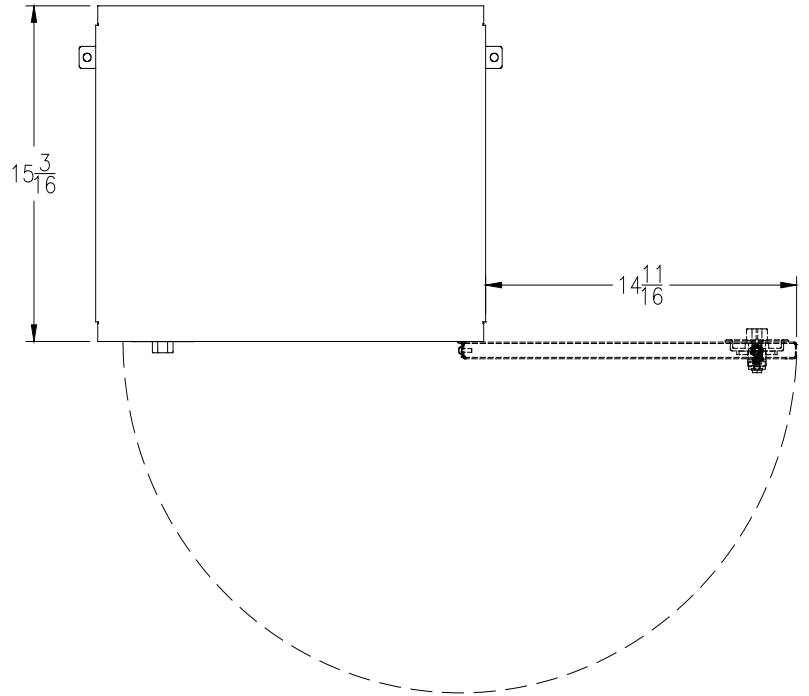
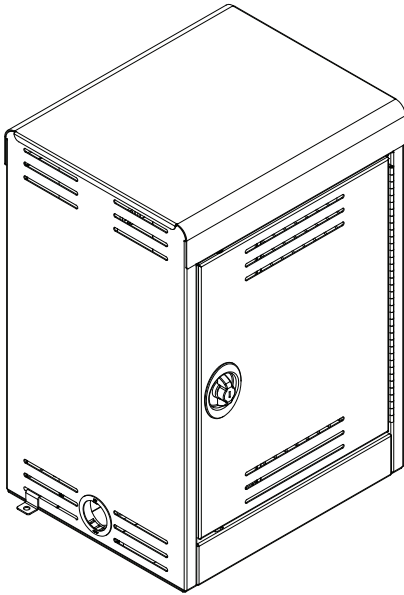

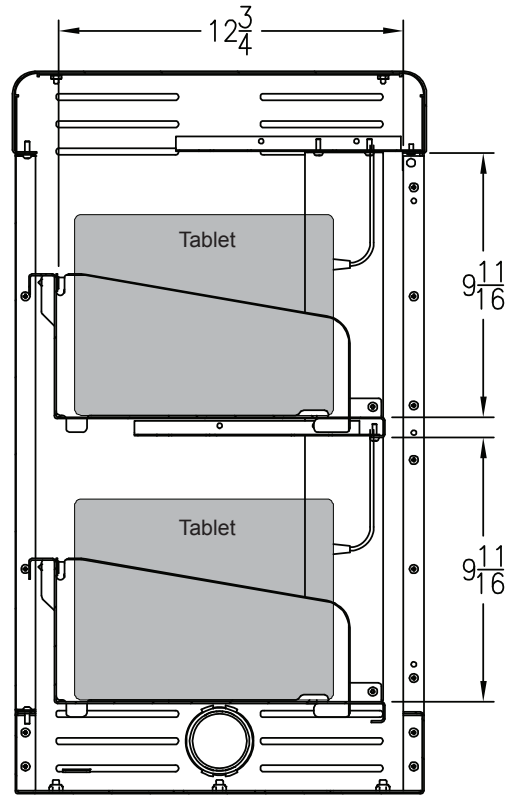
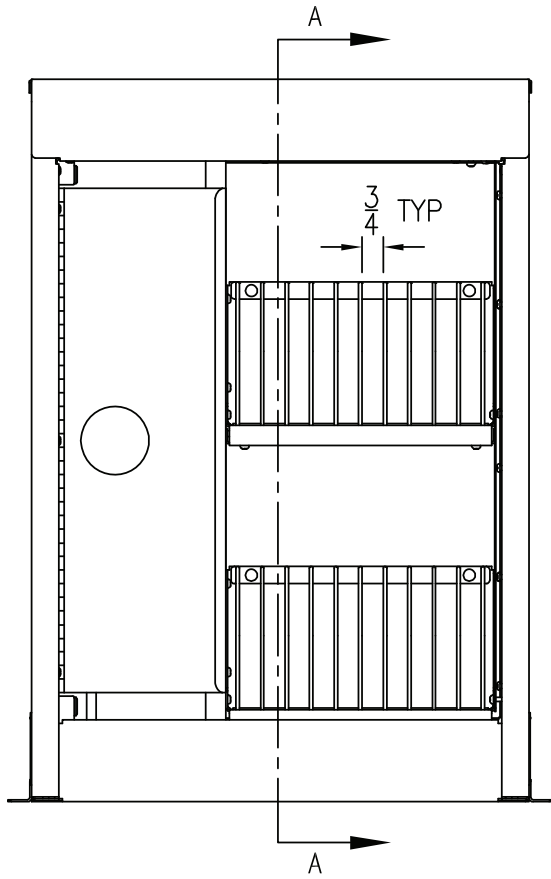

SECTION A-A

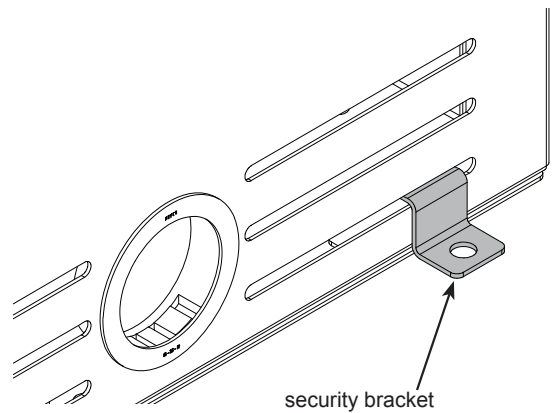
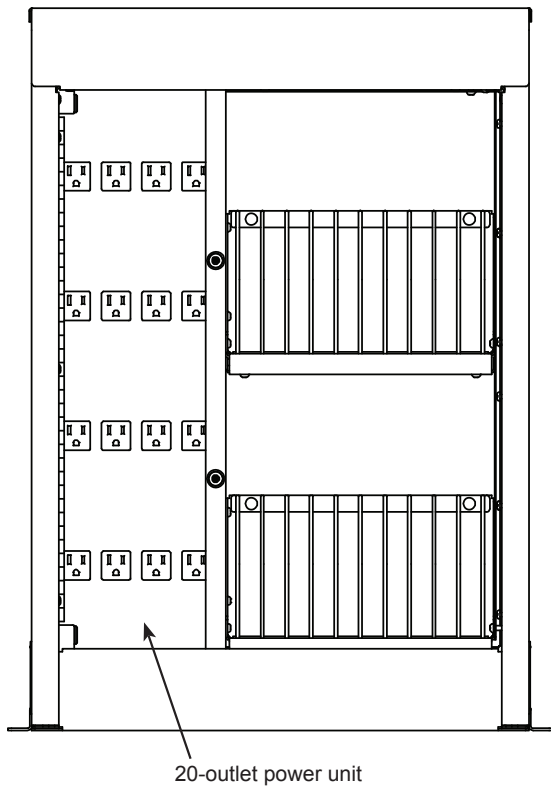

Options

Synchronizing USB Hubs 55448

Includes:

- (4) 7-port USB hubs with cables
- (1) 8-outlet power strip w/ rotating outlets
- (8) 3" x 2" Velcro® strips
- (15) zip ties



- Allows user/instructor laptop to synchronize tablet databases
- Utilizes industry standard hubs (USB 2.0/1.1/1.0) with data transfer up to 480 Mbps
- Includes diagnostic LEDs on hubs
- Hubs include Velcro® fasteners to attach to locker
- Best value option that provides the ability to charge and synchronize
- Can be used with iPad® tablets by plugging the USB cable into the AC power adapter (for charging) or USB hub port (for syncing) when needed (see below)



Rear View



Front View

Note: The optional USB hubs are for syncing only and do not provide charging capabilities through the USB ports. Supplementary charging through an AC adapter and outlet is still required.

Note: The iPad® has a single cord for charging and syncing (see below). This cord must be moved from the AC adapter to the hub for syncing. Many tablet devices use this same type of configuration. Some have a separate power cord and separate USB cord to accomplish both syncing and charging functions. Please consult the owners manual of your specific tablet device for further information.

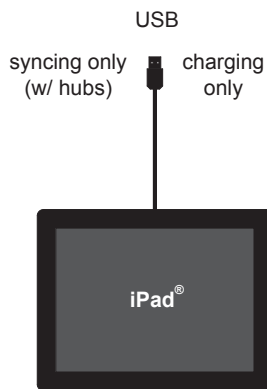
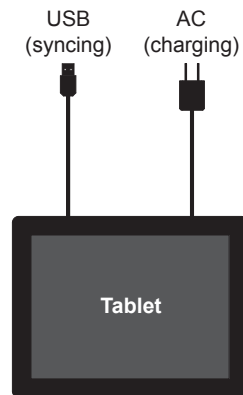

Minimum System Requirements

- Computer with Windows® 7, Windows Vista®, Windows® XP SP2, Windows® 2000 SP4, Mac OS® X 10.4 or higher
- Computer with USB 1.1 port

USB Hub Specs

Standards

- USB specification version 2.0 1 (data rates of up to 480 Mbps)
- USB specification version 1.1 (data rates of up to 12 Mbps)
- OHCI
- UHIC
- VEHCI

Interfaces

- 1 upstream USB 2.0 Type B (female) port
- 7 downstream USB 2.0 Type A (female) ports (including 2 Fast Charging ports)

Connectivity Rules

- Up to five cascaded hubs
- Maximum cable length between each hub: 5m
- Up to 127 devices

Diagnostic LED

- Standard Mode (blue)
- Fast-Charge Mode (green)

Supplied Charging Current

- Standard Mode:
 - All seven USB ports - 0.5 A per port 2
- Fast-Charge Mode:
 - 5 standard USB ports- 0.5 A per port 2
 - 2 USB fast charging ports - 1.2 A per port 2

Power Input

- + 5 V / 3 A DC

Dimensions (L x W x H)

- + 3.94 x 2.2 x 0.9 inches (100 x 57 x 23 mm)

Weight

- 0.19 lbs (85 g)

Operating Temperature

- 32 to 104°F (0 to 40°C)

Storage Temperature

- -4 to 158°F (-20 to 70°C)

Operating Humidity

- 5% to 95% (non-condensing)

Storage Humidity

- 0% to 95% (non-condensing)

Certifications

- FCC, CE, C-Tick, VCCI, IC, RoHS

Power Strip Specs

- 8-outlet surge protector with 6-foot cord
- Built to protect electronics
- Rotating outlets for ease of use; detachable cord-management clip for cable organization
- Right-angle plug keeps cord close to the wall
- Slim design
- Lifetime warranty and \$150,000 connected equipment warranty



Warranty

WE WILL MAKE IT RIGHT FOR YOU!

Spectrum is committed to provide complete customer satisfaction. Each of our products are manufactured from the best materials available and each product is stringently monitored throughout the production process through our P.A.C.E. program (Product Assurance to meet Customer Expectations). Our Customer Service Help Line 1-800-235-1262 is ready to provide immediate attention to any questions, comments or concerns. We are available to answer your calls Monday through Friday from 7 am to 5 pm CST, excluding observed holidays. In addition your product comments or concerns are welcome via e-mail at: spectrum@spectrumfurniture.com.

Warranty Statement

We guarantee all Spectrum products to be free of all defects in materials and workmanship, for the original owner, for a period of ten years. Any item deemed defective by Spectrum or the original manufacturer, under normal use conditions, will be repaired or replaced at Spectrum's discretion. This warranty applies to all products manufactured and distributed by Spectrum except the products listed below.

Items that have a varying warranty include, but are not limited to, the following:

- Adjustable Crank/Electric Desk Legs (1 yr)
- Flat Panel Desk Gas Cylinders (1 yr)
- Upholstered Soft-Goods (5 yrs)
- Adjustable Height & Stacking Chair Parts – including frames, gas cylinders, wood and plastic parts, and control handles (7 yrs)
- Adjustable Height & Stacking Chair Casters (2 yrs)
- Chair Upholstery & Textiles (2 yrs of normal use of Soft Goods, Adjustable Height, Stacking, Wood and Metal Chairs)
- Chair Upholstery - Graded-In Fabrics and C.O.M (no warranty)
- Height Adjustable Columns and Lifts (1 yr)
- General Use Casters (1 yr)
- Electrical – Electri-Pak, Power Communication Modules, and special order ECA electrical items (1 yr)
- Electrical - Power Strips & Electrical Timers (1 yr)
- Electrical Surge Suppressors (lifetime)
- Electrical - Retractable Power Cords (1 yr)
- Keyboard/Mouse Trays (1 yr)
- Flat Panel Monitor Arm – General Parts (5 yrs)
- Flat Panel Monitor Arm – Gas Cylinders (2 yrs)
- CRT Monitor Arm (1 yr)

Warranty is void if product is not used for its intended purpose or subjected to an unusual application, multiple-shift use, alteration, accident, abuse or abnormal wear and tear. Representations of colors on-line and in printed materials are meant to be a close reference to the actual colors but not an exact match. Slight variations in color and texture of wood stains, powder coating, laminates, fabrics and other materials are normal in different manufacturing lots; as such these variations are not considered defects.

DESIGNED FOR INDOOR USE ONLY – Unless specifically stated in the product specifications, Spectrum's products have been designed and constructed for indoor use only. Moving or using outdoors, or on excessively rough surfaces, may cause damage to the products and will void the warranty. If an outdoor application is desired please contact us to discuss potential custom design solutions.

The warranty, as stated above, supersedes any previous warranties and is effective as of 9/1/2010



205 Westwood Ave, Long Branch, NJ 07740
Phone: 866-94 BOARDS (26273) / (732)-222-1511
Fax: (732)-222-7088 | E-mail: sales@touchboards.com



INDOOR AIR QUALITY
Indoor Advantage | Furniture

