

Owner's Manual

SPECTRUM
INDUSTRIES INC. 

InTouch 20 Secure Tablet Locker

55447CW

InTouch 20 Secure Tablet Locker

Touchboards

205 Westwood Ave, Long Branch, NJ 07740
Phone: 866-94 BOARDS (26273) / (732)-222-1511
Fax: (732)-222-7088 | E-mail: sales@touchboards.com

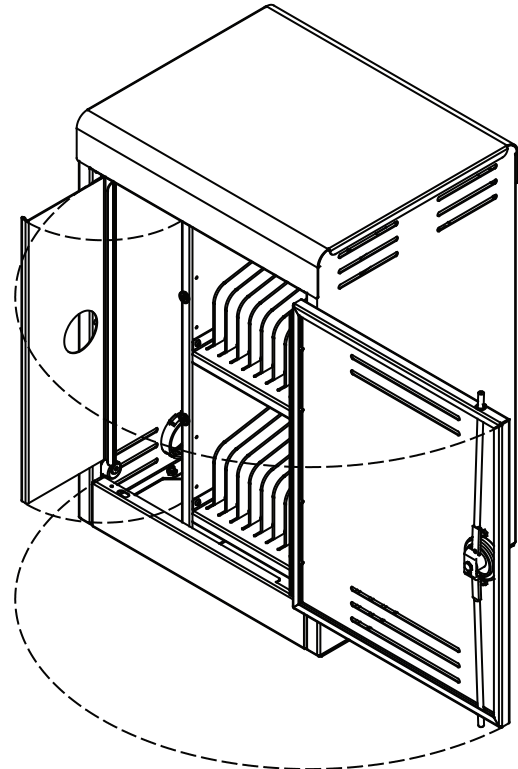
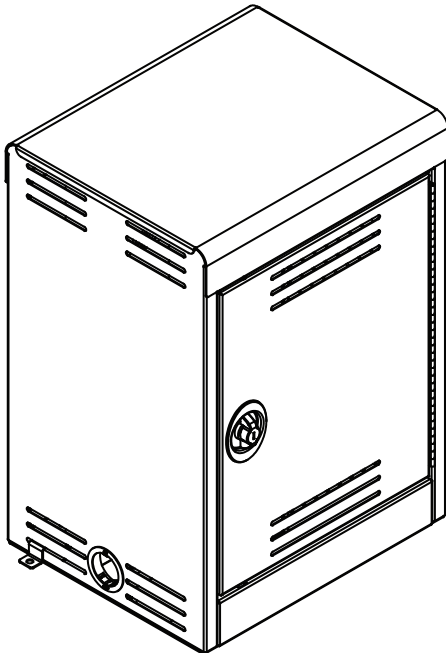

CAUTION:

Before using this product, read this manual and follow all safety and operating instructions.

Before you begin, please make sure all parts and proper quantities are included. Any parts damaged during shipment must be reported within 15 days of receipt. To report information regarding damages or if you have any questions, please call 1-800-235-1262.

To purchase parts or accessories, please contact us at
www.spectrumfurniture.com
1-800-235-1262

Thank you for purchasing Spectrum products!

Spectrum Industries, Inc
Chippewa Falls, WI 54729, USA

SPECTRUM
INDUSTRIES INC. 



Safety



- Read this owner's manual before assembly or operation.
- If attaching to a worksurface, be sure it is stable and sturdy enough to fully support the unit
- Do not allow children to operate
- For indoor use only. Do not install or store the unit where it will be exposed to weather. Keep unit dry.
- For added safety, plug the unit into a grounded three-prong receptacle controlled by a GFI (Ground Fault Interrupter) circuit breaker.

Hardware Package Contents

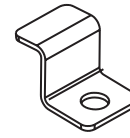

(2) 0111425
security bracket

Assembly / Setup

InTouch 20 tablet locker security

Spectrum recommends using the two attachment methods shown below to maximize the locker security.

A. Bottom Panel Mounting Holes

(3) 5/16" holes are provided on the bottom panel to attach the locker to a worksurface or floor for increased security. Fasteners are not included.

1. Set the locker into position. (If attaching to a worksurface, be sure it is stable and sturdy enough to fully support the unit.)
2. Choose fasteners appropriate to the surface you will be attaching to. The (3) mounting holes in the bottom panel are 5/16" dia. **Figure 1A.**
3. Mark the (3) hole locations through bottom panel.
4. At the marked locations, drill holes in the worksurface or floor appropriate to the chosen fastener type and size.
5. Install fasteners and tighten securely.

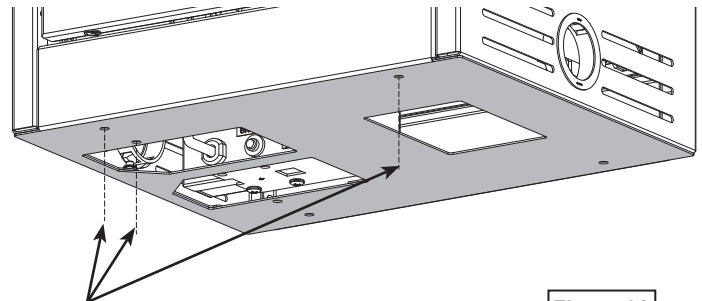

(3) 5/16" holes available for fastening locker to a worksurface or floor

Figure 1A

B. Security Brackets

The included security brackets can be installed to attach the locker to a secure worksurface or floor for increased security. Fasteners are not included.

1. Choose fasteners appropriate to the surface you will be attaching to. Each security bracket has a 3/8" diameter mounting hole.
2. Place each security bracket into one of the lower ventilation slots on each side of the locker as shown in **Figure 1B**. The bracket can be located anywhere along these slots.
3. Mark the bracket hole locations on the worksurface or floor.
4. At the marked locations, drill pilot holes appropriate to the chosen fastener type and size.
5. Install fasteners and tighten securely.

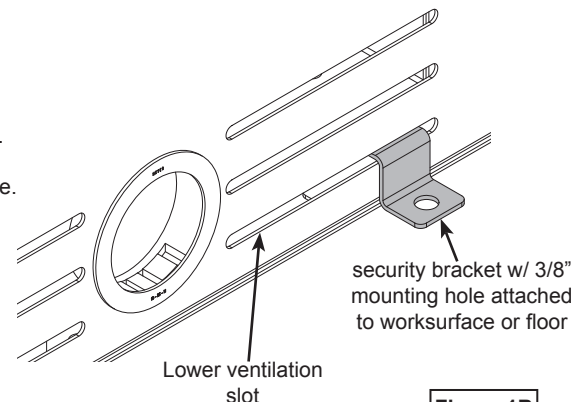

security bracket w/ 3/8" mounting hole attached to worksurface or floor

Lower ventilation slot

Figure 1B

Routing power cords to tablets

The wiring diagram below shows typical cord management for tablet power cords.

1. With the 20-outlet power unit unplugged, plug up to 20 tablet chargers into the locker power unit. **Figure 2A.**
2. Route the charge cords through the divider panel cutouts.
3. Using the cord wraps above each tablet storage slot, wrap excess cord while leaving enough cord length to drop down to each tablet. **Figure 2B.**
4. Excess cords can be bundled with zip ties and stored under the bottom shelf.



Figure 2B

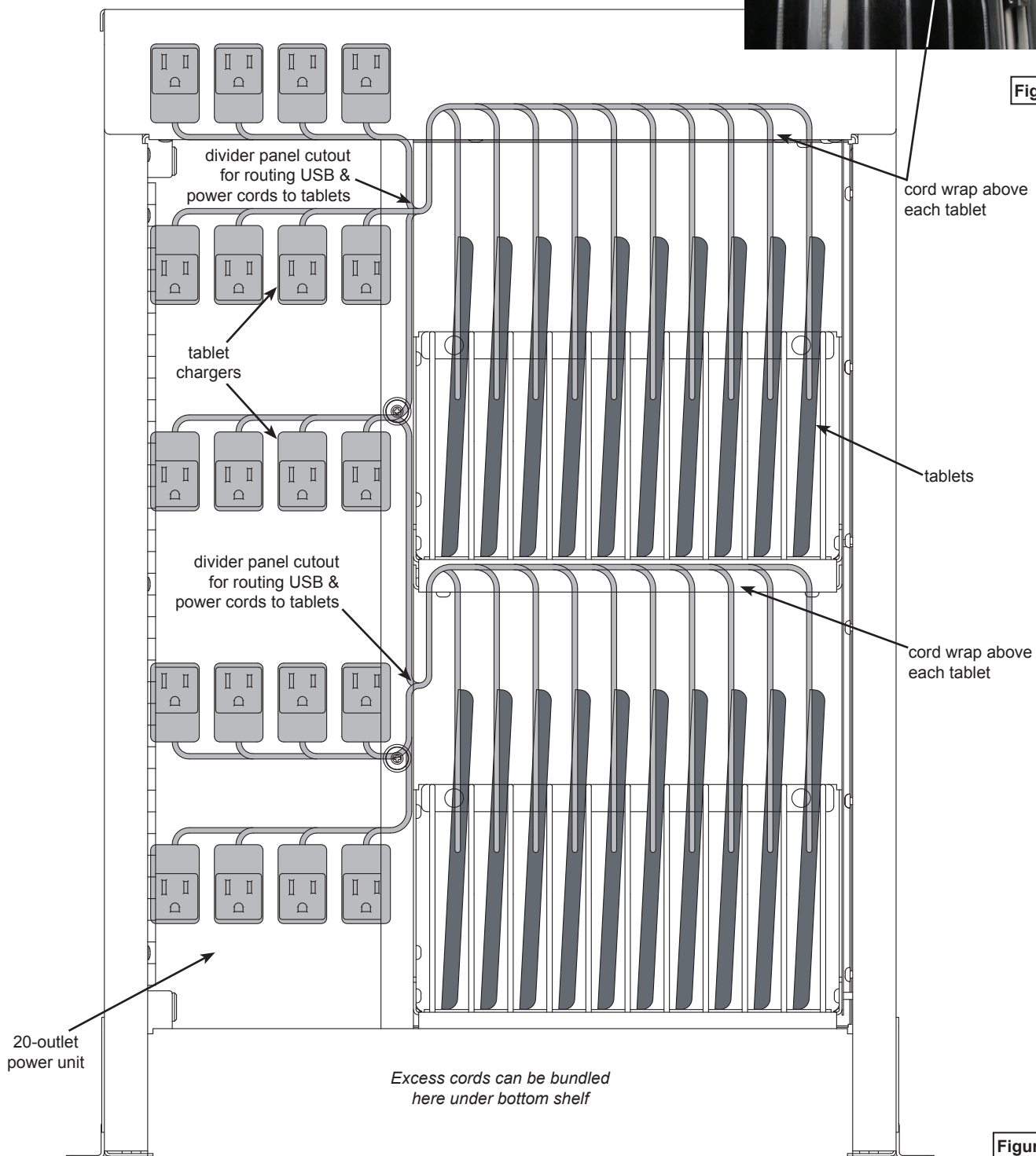

Figure 2A

Route USB hub cords to tablets (Hubs not included)

The wiring diagram below shows typical cord management when (4) USB hubs are used. USB hubs are not included with the Secure Laptop Locker, but available as an option. (See p.5)

1. Connect 3 USB cords to the "feeder hub". **Figure 3.**
2. Connect the other end of each cord to a hub on the divider panel. (Up to 20 USB cords can be connected to the hubs).
3. Route the cords through the divider panel cutouts.
4. Excess cords can be bundled with the included zip ties and stored under the bottom shelf.

Note: The iPad® has a single cord for charging *and* syncing. This cord must be moved from the power plug to the sync hub for syncing. Many tablet devices use this same type of configuration.

Some tablets have a separate power cord and separate USB cord to accomplish both syncing and charging functions. Please consult the owners manual of your specific device for further information.

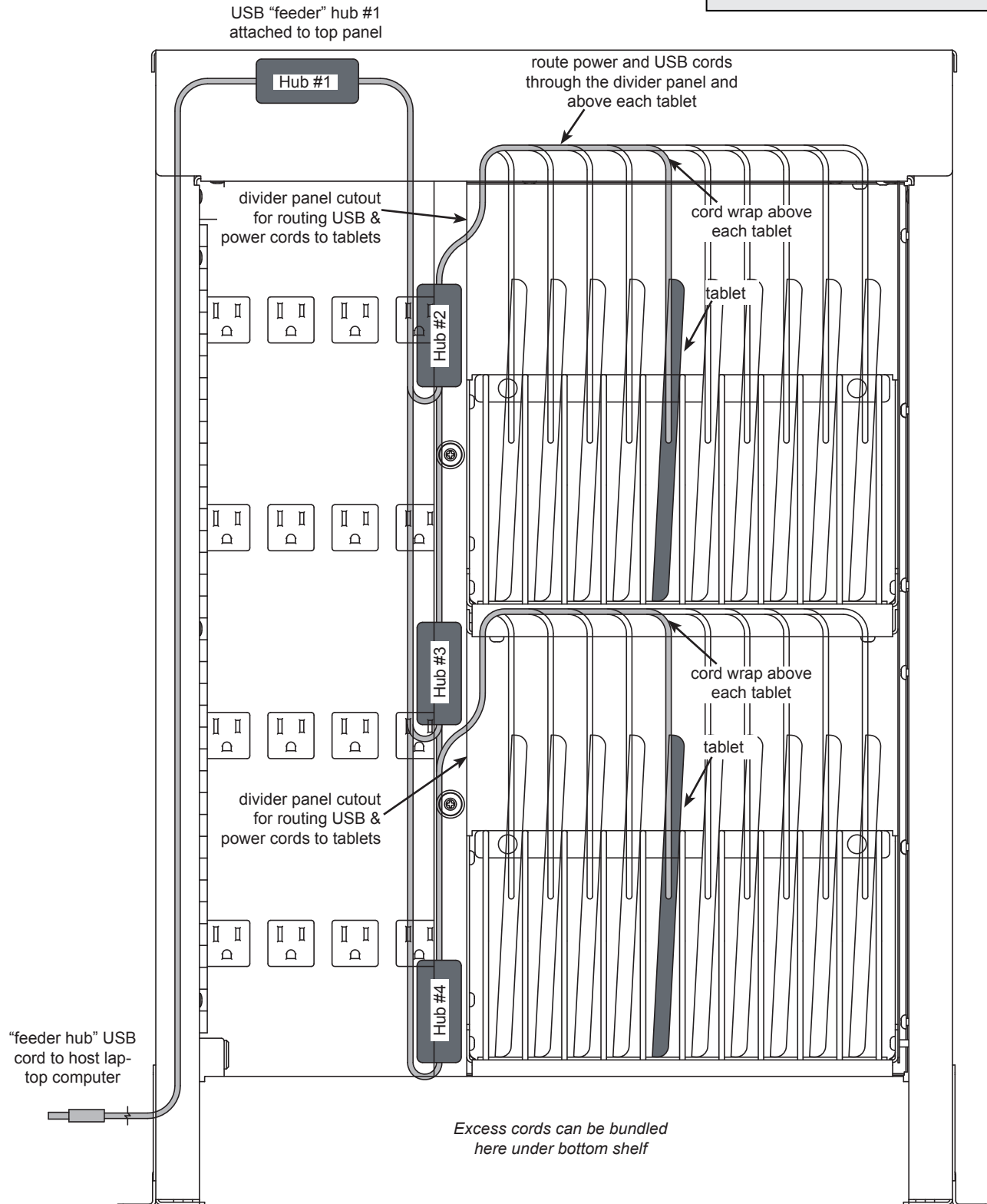

Figure 3

InTouch 20 Secure Tablet Locker Options

Charging & Syncing Hubs: 55448

Includes:

- (4) 7-port Synchronizing USB hubs w/ cables
- (1) 8-outlet power strip w/ rotating outlets
- (8) 3" x 2" Velcro® strips
- (15) Zip Ties

55448 instructions available at www.spectrumfurniture.com



Rear View



Front View

Note: The iPad® has a single cord for charging and syncing. This cord must be moved from the power plug to the sync hub for syncing. Many tablet devices use this same type of configuration. Some have a separate power cord and separate USB cord to accomplish both syncing and charging functions. Please consult the owners manual of your specific device for further information.

Minimum System Requirements

- Computer with Windows® 7, Windows Vista®, Windows® XP SP2, Windows® 2000 SP4
- Pentium 233-MHz or faster with 32MB RAM
- Computer with USB 1.1 Port

USB Hub Specs

Standards

- USB specification version 2.0 1 (data rates of up to 480 Mbps)
- USB specification version 1.1 (data rates of up to 12 Mbps)
- OHCI
- UHIC
- VEHCI

Interfaces

- 1 upstream USB 2.0 Type B (female) port
- 7 downstream USB 2.0 Type A (female) ports (including 2 Fast Charging ports)

Connectivity Rules

- Up to five cascaded hubs
- Maximum cable length between each hub: 5m
- Up to 127 devices

Diagnostic LED

- Standard Mode (blue)
- Fast-Charge Mode (green)

Supplied Charging Current

- Standard Mode:
 - All seven USB ports - 0.5 A per port 2
- Fast-Charge Mode:
 - 5 standard USB ports- 0.5 A per port 2
 - 2 USB fast charging ports - 1.2 A per port 2

Power Input

- + 5 V / 3 A DC

Dimensions (L x W x H)

- + 3.94 x 2.2 x 0.9 inches (100 x 57 x 23 mm)

Weight

- 0.19 lbs (85 g)

Operating Temperature

- 32 to 104 °F (0 to 40 °C)

Storage Temperature

- -4 to 158 °F (-20 to 70 °C)

Operating Humidity

- 5% to 95% (non-condensing)

Storage Humidity

- 0% to 95% (non-condensing)

Certifications

- FCC
- CE
- C-Tick
- VCCI
- IC
- RoHS

Power Strip Specs

- 8-outlet surge protector with 6-foot cord
- Built to protect electronics
- Rotating outlets for ease of use; detachable cord management clip for cable organization
- Right-angle plug keeps cord close to the wall
- Slim design
- Lifetime Warranty and \$150,000 Connected Equipment Warranty

Technical Details:

- Height:** 2.1 inches
- Length:** 13.5 inches
- Width:** 2.4 inches



Warranty

WE WILL MAKE IT RIGHT FOR YOU!

Spectrum is committed to provide complete customer satisfaction. Each of our products are manufactured from the best materials available and each product is stringently monitored throughout the production process through our P.A.C.E. program (Product Assurance to meet Customer Expectations). Our Customer Service Help Line 1-800-235-1262 is ready to provide immediate attention to any questions, comments or concerns. We are available to answer your calls Monday through Friday from 7 am to 5 pm CST, excluding observed holidays. In addition your product comments or concerns are welcome via e-mail at: spectrum@spectrumfurniture.com.

Warranty Statement

We guarantee all Spectrum products to be free of all defects in materials and workmanship, for the original owner, for a period of ten years. Any item deemed defective by Spectrum or the original manufacturer, under normal use conditions, will be repaired or replaced at Spectrum's discretion. This warranty applies to all products manufactured and distributed by Spectrum except the products listed below.

Items that have a varying warranty include, but are not limited to, the following:

- Adjustable Crank/Electric Desk Legs (1 yr)
- Flat Panel Desk Gas Cylinders (1 yr)
- Upholstered Soft-Goods (5 yrs)
- Adjustable Height & Stacking Chair Parts – including frames, gas cylinders, wood and plastic parts, and control handles (7 yrs)
- Adjustable Height & Stacking Chair Casters (2 yrs)
- Chair Upholstery & Textiles (2 yrs of normal use of Soft Goods, Adjustable Height, Stacking, Wood and Metal Chairs)
- Chair Upholstery - Graded-In Fabrics and C.O.M (no warranty)
- Height Adjustable Columns and Lifts (1 yr)
- General Use Casters (1 yr)
- Electrical – Electri-Pak, Power Communication Modules, and special order ECA electrical items (1 yr)
- Electrical - Power Strips & Electrical Timers (1 yr)
- Electrical Surge Suppressors (lifetime)
- Electrical - Retractable Power Cords (1 yr)
- Keyboard/Mouse Trays (1 yr)
- Flat Panel Monitor Arm – General Parts (5 yrs)
- Flat Panel Monitor Arm – Gas Cylinders (2 yrs)
- CRT Monitor Arm (1 yr)

Warranty is void if product is not used for its intended purpose or subjected to an unusual application, multiple-shift use, alteration, accident, abuse or abnormal wear and tear. Representations of colors on-line and in printed materials are meant to be a close reference to the actual colors but not an exact match. Slight variations in color and texture of wood stains, powder coating, laminates, fabrics and other materials are normal in different manufacturing lots; as such these variations are not considered defects.

DESIGNED FOR INDOOR USE ONLY – Unless specifically stated in the product specifications, Spectrum's products have been designed and constructed for indoor use only. Moving or using outdoors, or on excessively rough surfaces, may cause damage to the products and will void the warranty. If an outdoor application is desired please contact us to discuss potential custom design solutions.

The warranty, as stated above, supersedes any previous warranties and is effective as of 9/1/2010

Touchboards

205 Westwood Ave, Long Branch, NJ 07740
Phone: 866-94 BOARDS (26273) / (732)-222-1511
Fax: (732)-222-7088 | E-mail: sales@touchboards.com

SCScertified™

INDOOR AIR QUALITY
Indoor Advantage | Furniture



SPECTRUM
INDUSTRIES INC.

925 First Avenue, PO Box 400, Chippewa Falls, WI 54729 Ph: 800-235-1262, 715-723-6750 Fax: 800-335-0473, 715-738-2309

E-mail: spectrum@spectrumfurniture.com web: www.spectrumfurniture.com